

规格承认书

SPECIFICATION FOR APPROVAL

客户 Customer	睿联
项目名称 Project Name	SD7
客户料号 Customer NO.	
规格 specification	双频WIFI天线-W
供方料号 Supplier NO.	N12-8254-R0B
规格书编号 Specification NO.	
编写人 Write by	张斌
版本 REV.	Ver.1
日期 Date	2022/5/24
备注 Note	

客户确认 CUSTOMER APPROVED BY		
批准 Approved by	审核 Checked by	制表 Prepared by
供方确认 SUPPLIER APPROVED BY		
批准 Approved by	审核 Checked by	制表 Prepared by

1. 承认书项目表 (Index)

Serial number	内容	pagination
-	Admit the cover	1
-	Version change log	2
1	Admission book item table	3
2	Test equipment and conditions	4
3	Prototype structure description	5
4	S11	7
5	Gain/Efficiency /3D graph	8
6	Package drawing	9

2. 试验设备和条件(Test Equipment & Conditions)

2.1. Network Analyzers : KEYSIGHT P5002A

2.2. Communications Test Set: R&S CMW 500

2.3. 3D Chamber Test System: 64探头测试系统



3. 样机结构说明件(Mechanical instruction)



Rev	Description	Date	Remark
A	New drawing		

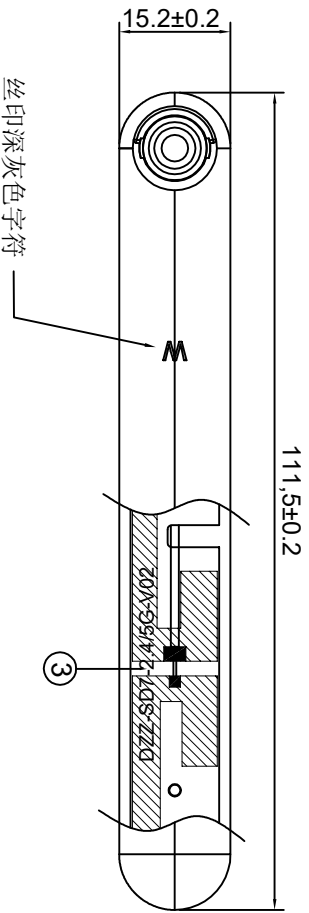
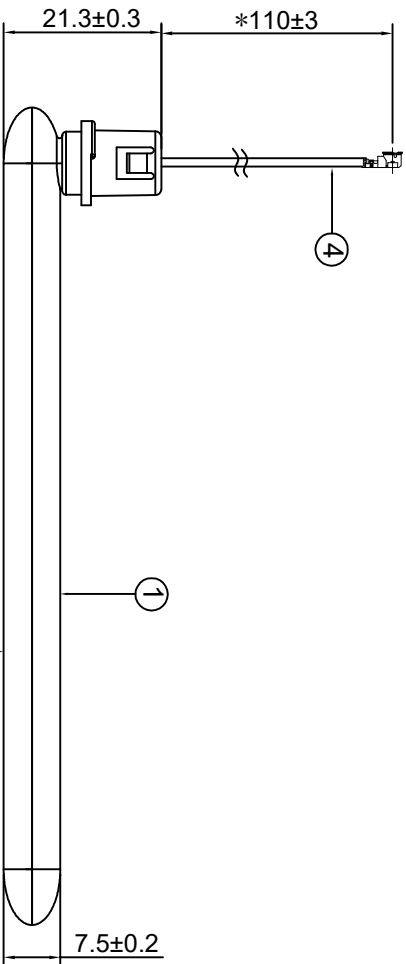

- 技术要求:
1. 标“*”尺寸为重点管控尺寸;
 2. 未标注尺寸依照图纸;
 3. 无虚焊、假焊、连锡、短路、断路等焊接不良现象;
 4. 所有部件需符合RoHS要求;
 5. 成品需全检性能。

No.	Part No.	Name	Specification	Amount	Remark
4		射绑线	1.13 双锡线 黑色+一代端子	1	
3		PCB	单面板 FR4 0.8MM 绿色	1	
2		下壳	白色	1	
1		上壳	白色	1	

Be-Comfortable
得自在

深圳市得自在科技有限公司
SHEN ZHEN BE-COMFORTABLE CO., LTD

Third Angle	Project	SD7	Date	2022-05-31	
0~10 ±0.05	Part Name	WiFi 天线	Designed by	赵同延	
10~18 ±0.10	Part No.	N12-8254-R0A	Checked by	张斌	
18~30 ±0.12	Material	/	Approved by		
30~40 ±0.15	DWG No.		Unit	mm	Scale
40~ ±0.20	Location		mm	1:1	Rev
Angle			±0.5°		A

4. S11驻波比2.5以下

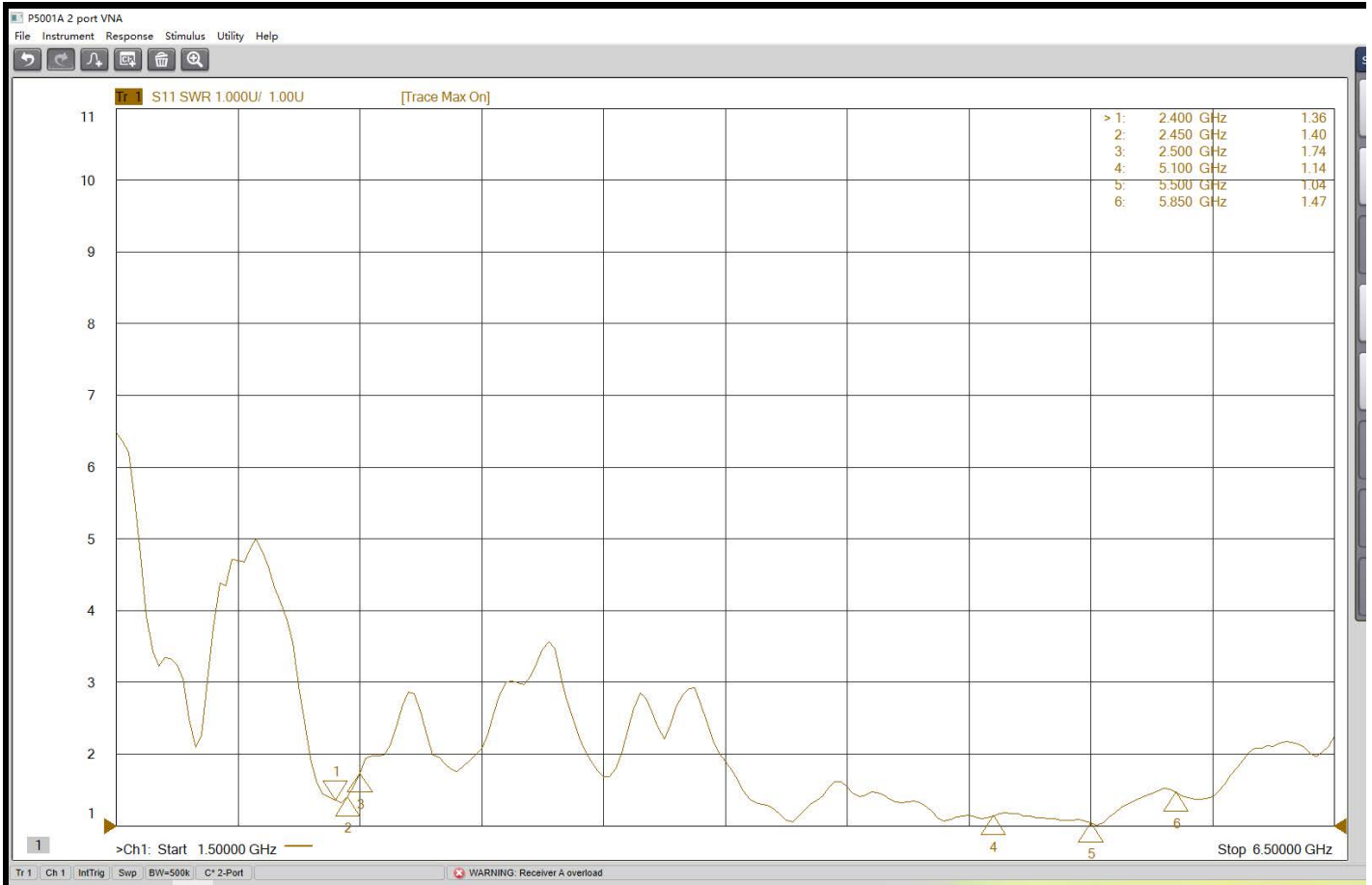

5. 增益/效率/3D图(Gain & Efficiency& 3D Pattern)

Frequency ID	1	2	3	4	5	6	7	8	9	10	11
Frequency (MHz)	2400.0	2410.0	2420.0	2430.0	2440.0	2450.0	2460.0	2470.0	2480.0	2490.0	2500.0
Gain (dBi)	3.12	3.05	3.01	2.66	2.12	1.80	1.95	2.34	2.64	2.74	2.94
Efficiency (%)	74.71	73.02	71.01	68.74	66.16	64.54	64.47	67.78	71.50	71.97	73.73

12	13	14	15	16	17	18	19	20	21	22	23	24	25	26
5150.0	5200.0	5250.0	5300.0	5350.0	5400.0	5450.0	5500.0	5550.0	5600.0	5650.0	5700.0	5750.0	5800.0	5850.0
3.66	3.56	3.75	4.50	4.12	3.94	3.61	3.07	3.01	3.32	3.37	3.78	3.89	4.20	4.29
65.91	62.76	65.14	65.17	67.59	67.51	65.64	67.33	68.06	68.19	69.62	72.05	72.04	73.79	74.13

3D Pattern @2400-2500/5150-5850MHZ

2400MHZ

XZ

YZ

XY

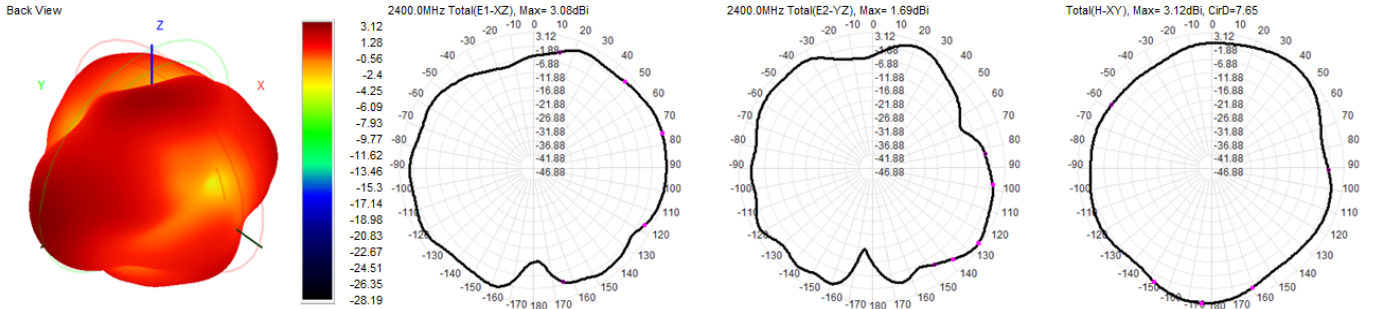

2500MHZ

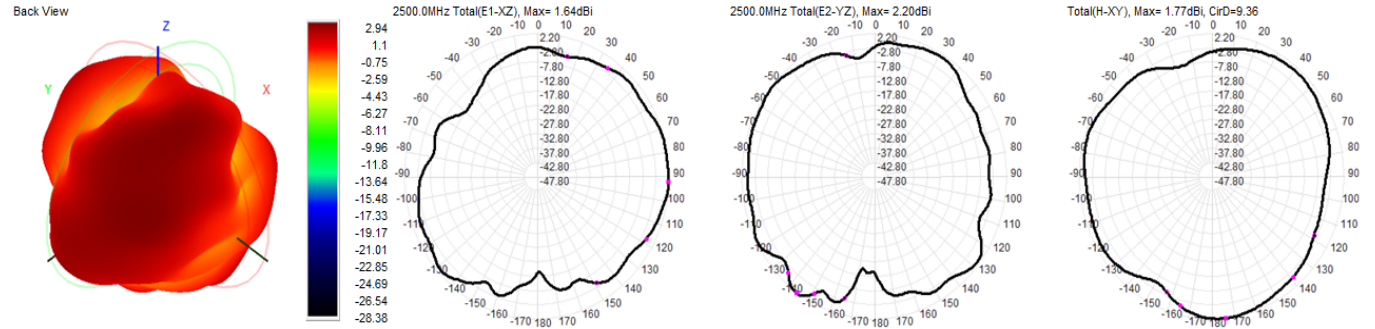

5150MHZ

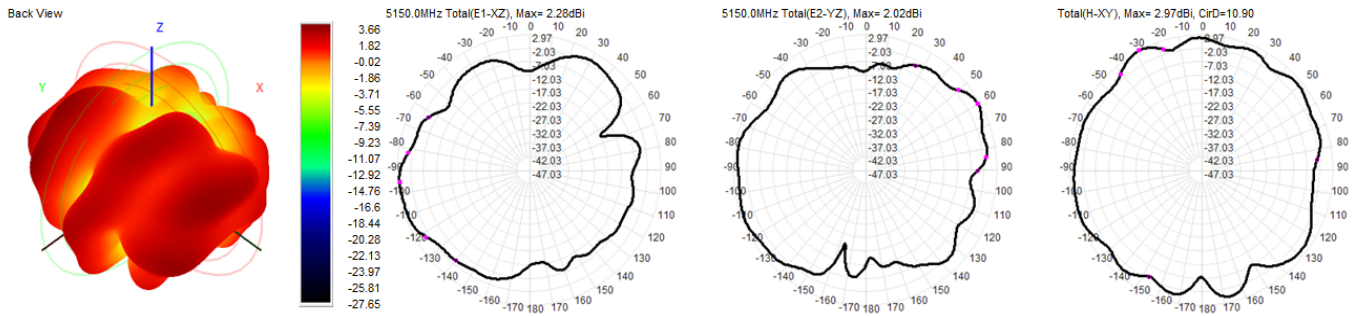

5850MHZ

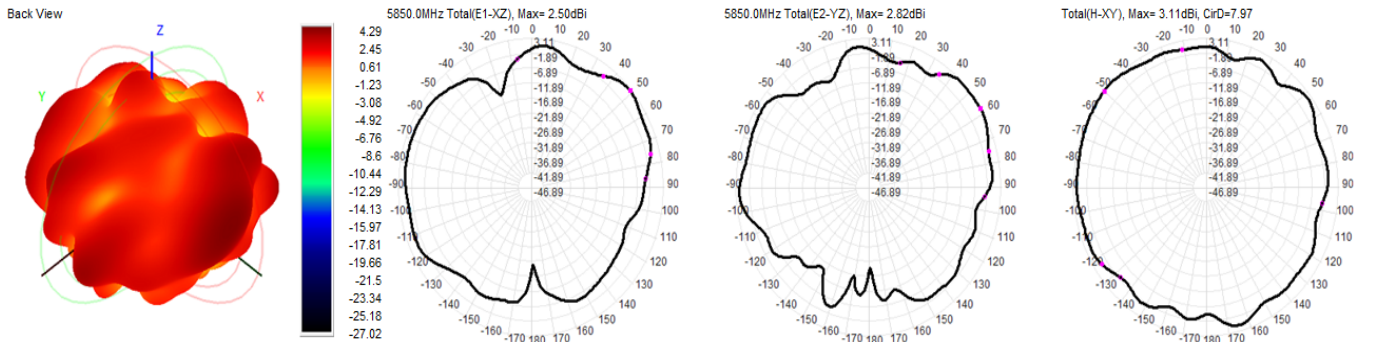

产品包装规范

日期: 2022-05-24

page: 1 of 1

成品名称 :SD7-WIFI天线	版本: A
	客户: 睿联

一: 成品天线

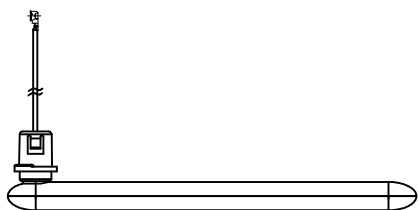

二: 装袋, 每PE袋装50PCS产品
端子用泡棉包扎。

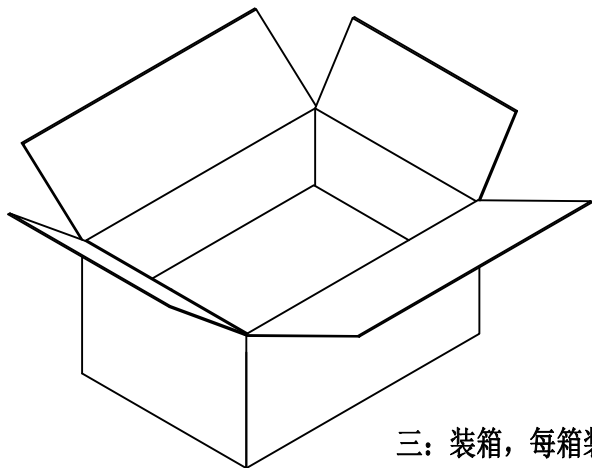

三: 装箱, 每箱装12袋, 共600 PCS产品(以实际包装为准)。

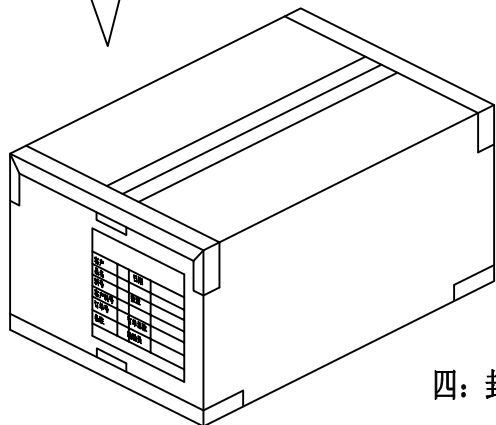
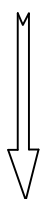

四: 封箱, 外箱贴我司生产标签和ROHS标签。

批准: _____

确认: _____

拟制: 赵同廷

由 Autodesk 教育版产品制作

由 Autodesk 教育版产品制作