

# Quick Start Guide

Apply to: Reolink Duo 2 WiFi

## Content

What's in the Box	2
Camera Introduction	3
Connection Diagram	5
Set up the Camera	6
Mount the Camera	7
Troubleshooting	12
Specification	13
Notification of Compliance	13

## What's in the Box

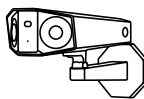

Camera



Antenna \*



Waterproof Lid

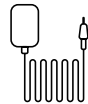

Power Adapter \*



1M  
Ethernet Cable

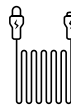

Power \*  
Extension Cable

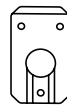

Mounting Plate

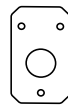

Mounting Hole  
Template



Quick Start Guide



Surveillance Sign

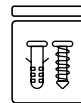

Pack of Screws

### NOTE:

\* The power adapter, antennas and 4.5m Power Extension Cable only come with WiFi Camera.

\* Quantity of accessories varies with the camera model you purchase.

## Camera Introduction

### WiFi Camera

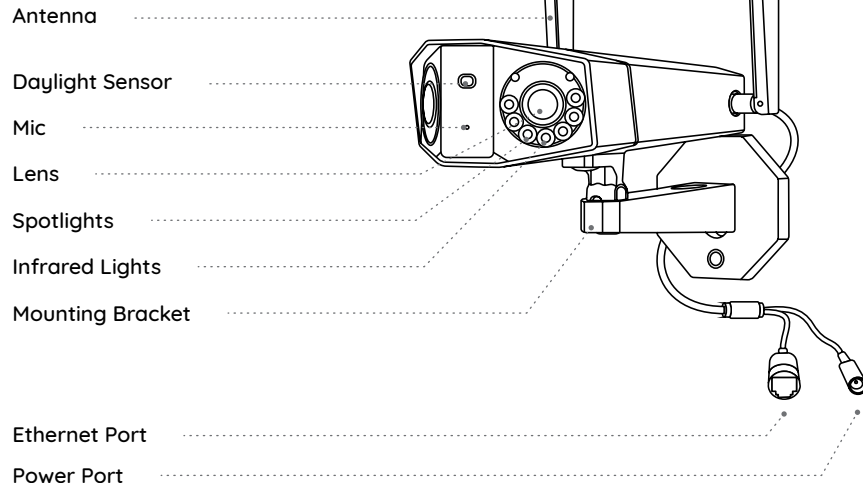

Micro SD Card Slot

Reset Button

\*Press the reset button with a pin to restore factory settings.

Speaker

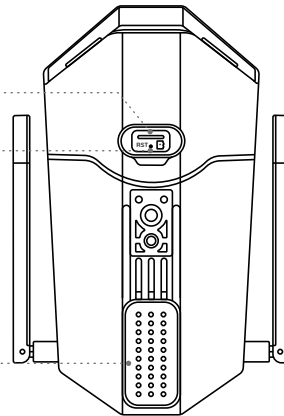

## Connection Diagram

Before initial setup, follow the steps below to connect your camera.

1. Connect the camera to a LAN port on your router with an Ethernet cable.
2. Use the power adapter to power on the camera.

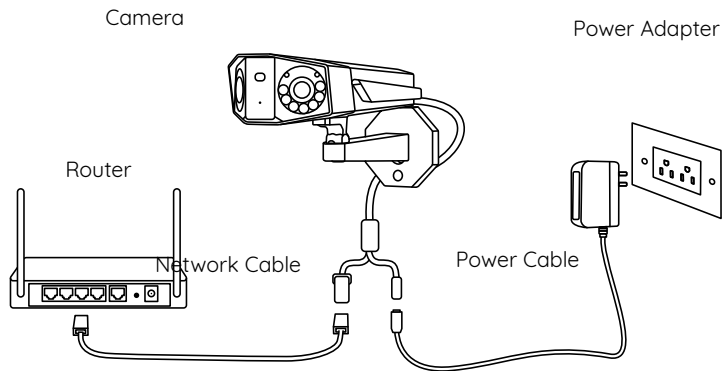

## Set up the Camera

Download and Launch the Reolink App or Client software, and follow the onscreen instructions to finish initial setup.

- **On Smartphone**

Scan to download the Reolink App.



- **On PC**

Download path of the Reolink Client: Go to <https://reolink.com> > Support > App & Client.

## Mount the Camera

### Installation Tips

- Do not face the camera towards any light sources.
- Do not point the camera towards a glass window. Or, it may result in poor image quality because of the window glare by infrared LEDs, ambient lights or status lights.
- Do not place the camera in a shaded area and point it towards a well-lit area. Or, it may result in poor image quality. To ensure best image quality, the lighting condition for both the camera and the capture object shall be the same.
- To ensure better image quality, it's recommended to clean the lens with a soft cloth from time to time.
- Make sure the power ports are not directly exposed to water or moisture and not blocked by dirt or other elements.
- With IP waterproof ratings, the camera can work properly under conditions like rain and snow. However, it doesn't mean the camera can work underwater.
- Do not install the camera at places where rain and snow can hit the lens directly.
- The camera may work in extreme cold conditions as low as -25°C. Because when it is powered on, the camera will produce heat. You may power on the camera indoors for a few minutes before installing it outdoors.
- Try to keep the left lens level with the right lens.

### Mount the Camera to the Wall

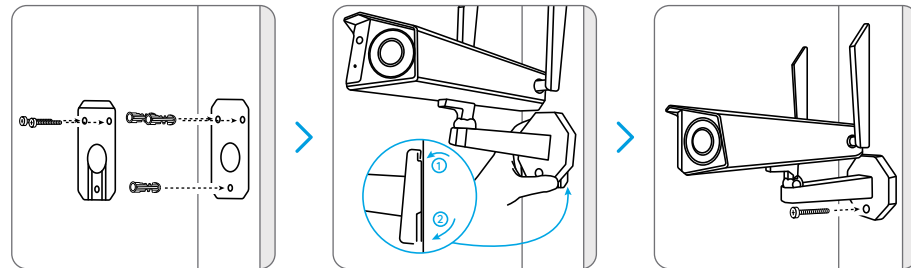

Drill holes in accordance with the mounting template, Secure the mounting plate to the wall with the upper two screws and hang the camera on it. Then lock the camera in position with the lower screw.

**NOTE:** Use the drywall anchors included in the package if needed.

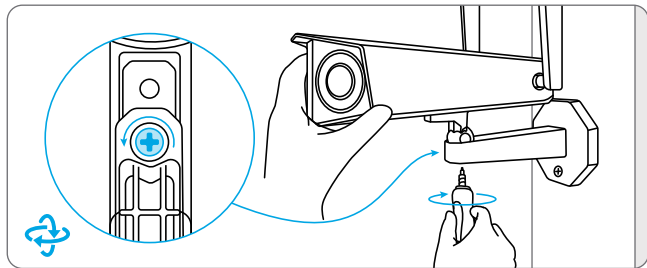

To get the best field of view, loosen the adjustment screw on security mount and turn the camera.

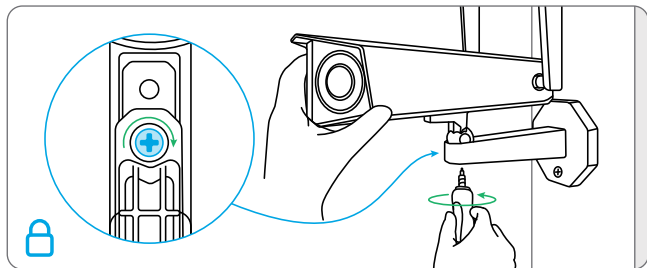

Stiffen the adjustment screw to lock the camera.

## Mount the Camera to Ceiling

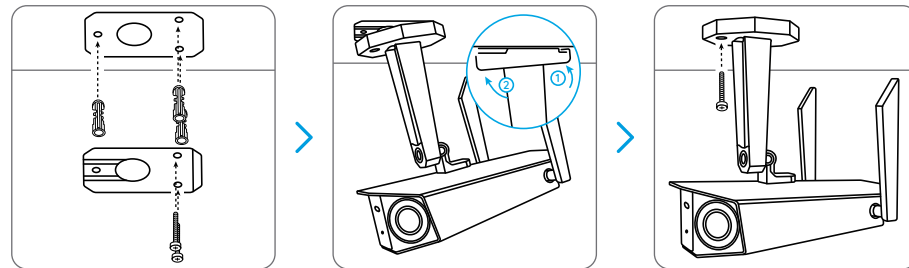

Drill holes in accordance with the mounting template, Secure the mounting plate to the wall with the upper two screws and hang the camera on it. Then lock the camera in position with the lower screw.

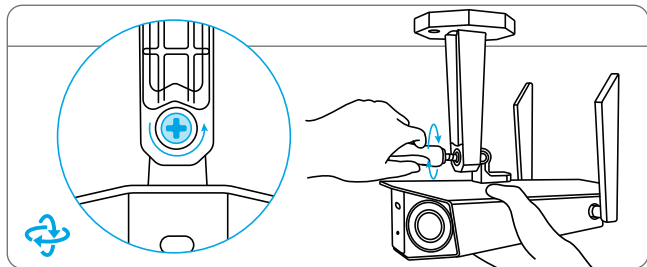

To get the best field of view, loosen the adjustment screw on security mount and turn the camera.

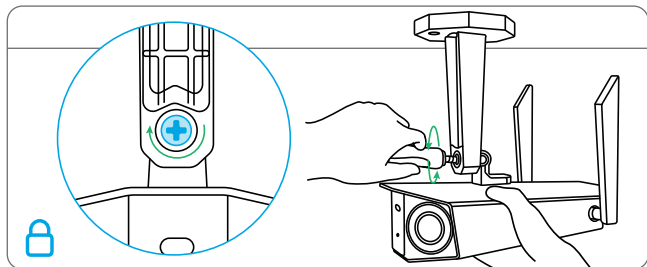

Stiffen the adjustment screw to lock the camera.

## Troubleshooting

### Camera is not Powering on

If your camera is not powering on, please try the following solutions:

- Plug the camera into a different outlet and see if it works.
- Power on the camera with another working 12V 2A DC adapter and see if it works.

If these won't work, contact Reolink Support.

### Picture is not Clear

If the picture from the camera is not clear, please try the following solutions:

- Check the camera lens for dirt, dust or spiderwebs, please clean the lens with a soft, clean cloth.
- Point the camera to a well-lit area, the lighting condition will affect the picture quality a lot.
- Upgrade the firmware of your camera to the latest version.
- Restore the camera to factory settings and check out again.

## Specification

### Hardware Features

Infrared Night Vision: Up to 30 meters  
Day/Night Mode: Auto switchover  
Angle of View: Horizontal: 180°, vertical: 60°

### General

Dimension: 195 x 103 x 56mm  
Weight: 700g  
Operating Temperature:  
-10°C~+55°C (14°F~131°F)  
Operating Humidity: 10% ~ 90%

For more specifications, visit  
<https://reolink.com/>.

## Notification of Compliance

### FCC Compliance Statements

This device complies with Part 15 of the FCC Rules. Operation is subject to the following two conditions: (1) this device may not cause harmful interference, and (2) this device must accept any interference received, including interference that may cause undesired operation.

**Note:** This equipment has been tested and found to comply with the limits for a Class B digital device, pursuant to Part 15 of the FCC Rules. These limits are designed to provide reasonable protection against harmful interference in a residential installation. This equipment generates, uses and can radiate radio frequency energy and, if not installed and

used in accordance with the instructions, may cause harmful interference to radio communications. However, there is no guarantee that interference will not occur in a particular installation. If this equipment does cause harmful interference to radio or television reception, which can be determined by turning the equipment off and on, the user is encouraged to try to correct the interference by one or more of the following measures:

- Reorient or relocate the receiving antenna.
- Increase the separation between the equipment and receiver.
- Connect the equipment into an outlet on a circuit different from that to which the receiver is connected.
- Consult the dealer or an experienced radio/TV technician for help.

Caution: Changes or modifications

not expressly approved by the party responsible for compliance could void the user's authority to operate the equipment.

### FCC Radiation Exposure statement

This equipment complies with FCC radiation exposure limits set forth for an uncontrolled environment. This equipment should be installed and operated with minimum distance 20cm between the radiator and your body.