

TEST REPORT

Report No.: BCTC2401689329-2E

Applicant: REOLINK INNOVATION LIMITED

Product Name: WiFi IP Camera

Test Model: Reolink Argus 3 Pro

Tested Date: 2024-01-25 to 2024-02-20

Issued Date: 2024-02-21

Shenzhen BCTC Testing Co., Ltd.



FCC ID: 2AYHE-2305A

Product Name: WiFi IP Camera

Trademark: 

Model/Type reference: Reolink Argus 3 Pro
Argus Series B330

Prepared For: REOLINK INNOVATION LIMITED

Address: FLAT/RM 705 7/F FA YUEN COMMERCIAL BUILDING 75-77 FA YUEN STREET MONG KOK KL HONG KONG

Manufacturer: REOLINK INNOVATION LIMITED

Address: FLAT/RM 705 7/F FA YUEN COMMERCIAL BUILDING 75-77 FA YUEN STREET MONG KOK KL HONG KONG

Factory: Shenzhen Reolink Technology Co., Ltd.

Address: 2-4th Floor, Building 2, YuanLing Industrial Park, ShangWu, Shiyan Street, Bao'an District, Shenzhen, China

Prepared By: Shenzhen BCTC Testing Co., Ltd.

Address: 1-2/F., Building B, Pengzhou Industrial Park, No.158, Fuyuan 1st Road, Zhancheng, Fuhai Subdistrict, Bao'an District, Shenzhen, Guangdong, China

Sample Received Date: 2024-01-25

Sample tested Date: 2024-01-25 to 2024-02-20

Issue Date: 2024-02-21

Report No.: BCTC2401689329-2E

Test Standards: FCC Part15 15.407
ANSI C63.10-2013
KDB 662911 D01 v02r01
KDB 789033 D02 v02r01

Test Results: PASS

Tested by:

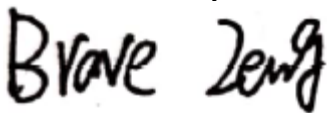

Brave Zeng/ Project Handler

Approved by:



Zero Zhou/Reviewer

The test report is effective only with both signature and specialized stamp. This result(s) shown in this report refer only to the sample(s) tested. Without written approval of Shenzhen BCTC Testing Co., Ltd, this report can't be reproduced except in full. The tested sample(s) and the sample information are provided by the client.

Table Of Content

	Page
Test Report Declaration	
1. Version	5
2. Test Summary	6
3. Measurement Uncertainty	7
4. Product Information And Test Setup	8
4.1 Product Information.....	8
4.2 Test Setup Configuration	8
4.3 Support Equipment	9
4.4 Channel List.....	9
4.5 Test Mode	10
5. Test Facility And Test Instrument Used.....	11
5.1 Test Facility.....	11
5.2 Test Instrument Used.....	11
6. Conducted Emissions.....	13
6.1 Block Diagram Of Test Setup.....	13
6.2 Limit	13
6.3 Test Procedure	13
6.4 EUT Operating Conditions	13
6.5 Test Result.....	14
7. Radiated Emissions.....	16
7.1 Block Diagram Of Test Setup.....	16
7.2 Limit	17
7.3 Test Procedure	18
7.4 EUT Operating Conditions	19
7.5 Test Result.....	19
8. Power Spectral Density Test	26
8.1 Block Diagram Of Test Setup.....	26
8.2 Limit	26
8.3 Test Procedure	27
8.4 EUT Operating Conditions	27
8.5 Test Result.....	28
9. 26dB & 6dB & 99% Emission Bandwidth	36
9.1 Block Diagram Of Test Setup.....	36
9.2 Limit	36
9.3 Test Procedure	36
9.4 EUT Operating Conditions	37
9.5 Test Result.....	38
10. Maximum Conducted Output Power.....	52
10.1 Block Diagram Of Test Setup.....	52
10.2 Limit	52
10.3 Test Procedure	52
10.4 EUT Operating Conditions	53
10.5 Test Result.....	54
11. Out Of Band Emissions	55

11.1	Block Diagram Of Test Setup.....	55
11.2	Limit	55
11.3	Test Procedure	55
11.4	EUT Operating Conditions	55
11.5	Test Result.....	56
12.	Spurious RF Conducted Emissions.....	60
12.1	Block Diagram Of Test Setup.....	60
12.2	Limit	60
12.3	Test Procedure	60
12.4	Test Result.....	60
13.	Frequency Stability Measurement.....	67
13.1	Block Diagram Of Test Setup.....	67
13.2	Limit	67
13.3	Test Procedure	67
13.4	Test Result.....	68
14.	Antenna Requirement	74
14.1	Limit	74
14.2	Test Result.....	74
15.	EUT Photographs.....	75
16.	EUT Test Setup Photographs.....	76

(Note: N/A Means Not Applicable)

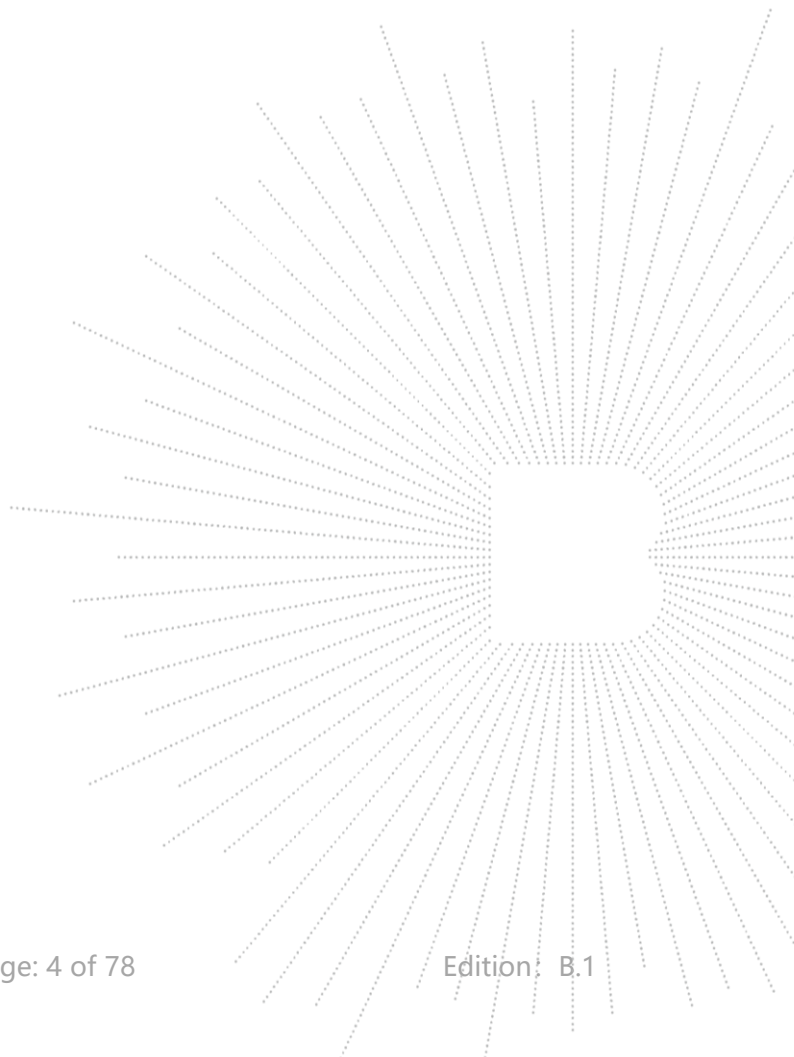

1. Version

Report No.	Issue Date	Description	Approved
BCTC2401689329-2E	2024-02-21	Original	Valid

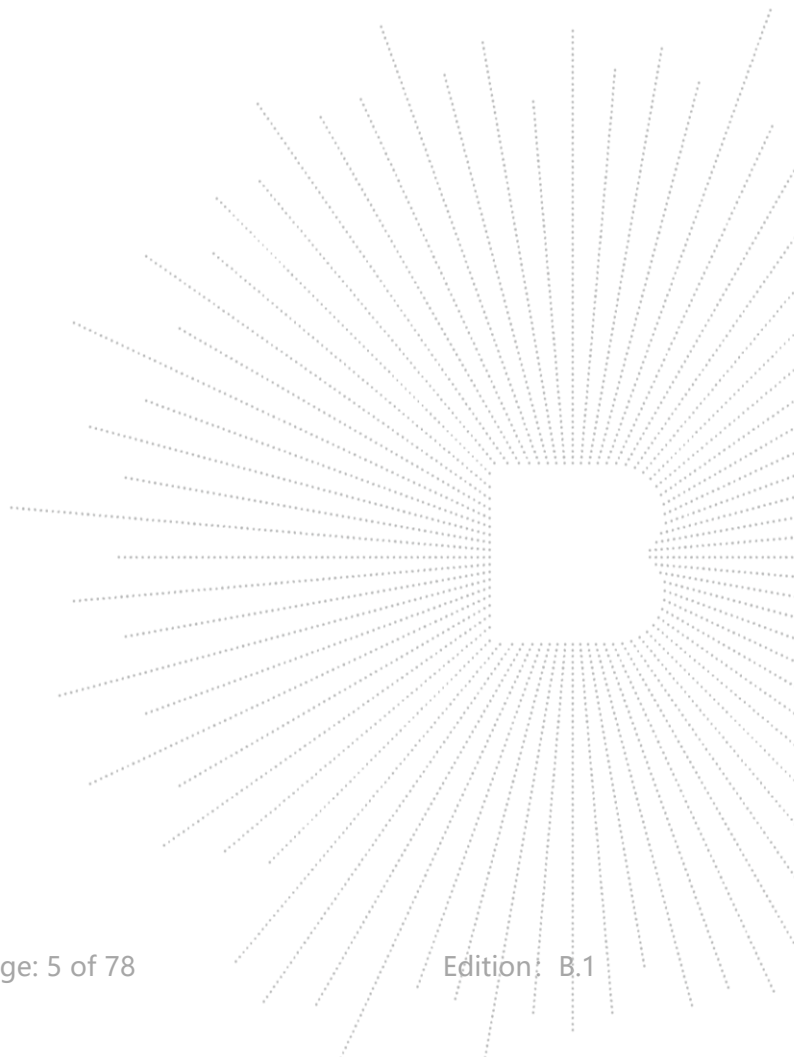

2. Test Summary

The Product has been tested according to the following specifications:

No.	Test Parameter	Clause No	Results
1	Spurious Radiated Emissions	15.209(a), 15.407 (b)(1) 15.407 (b)(4) 15.407 (b)(8)	PASS
2	Conducted Emission	15.207	PASS
3	26 dB and 99% Emission Bandwidth	15.407 (a)(12) 15.1049	PASS
4	Minimum 6 dB bandwidth	15.407(e)	PASS
5	Maximum Conducted Output Power	15.407 (a)(1) 15.407 (a)(3)	PASS
6	Band Edge	2.1051, 15.407(b)(1) 15.407(b)(4)	PASS
7	Power Spectral Density	15.407 (a)(1) 15.407 (a)(3)	PASS
8	Spurious Emissions at Antenna Terminals	2.1051, 15.407(b)	PASS
9	Antenna Requirement	15.203	PASS

Note: The device shall automatically discontinue transmission in case of either absence of information to transmit or operational failure.

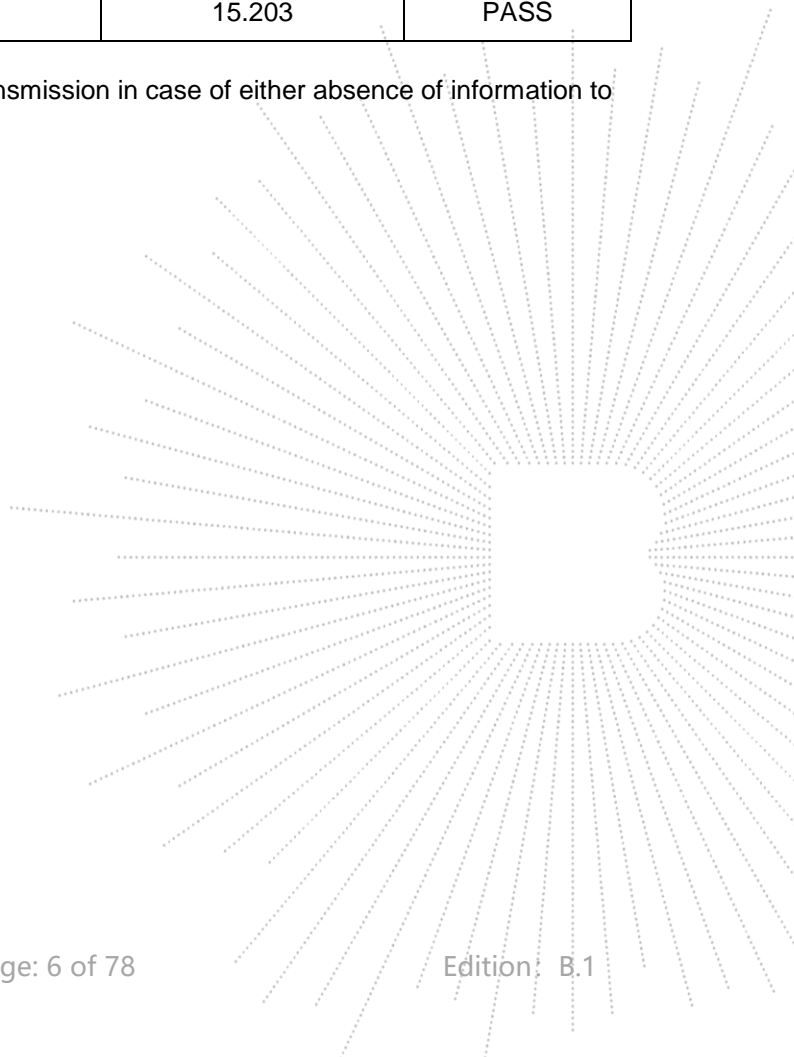

3. Measurement Uncertainty

Where relevant, the following measurement uncertainty levels have been estimated for tests performed on the Product as specified in CISPR 16-4-2. This uncertainty represents an expanded uncertainty expressed at approximately the 95% confidence level using a coverage factor of k=2.

No.	Item	Uncertainty
1	3m chamber Radiated spurious emission(9kHz-30MHz)	U=3.7dB
2	3m chamber Radiated spurious emission(30MHz-1GHz)	U=4.3dB
3	3m chamber Radiated spurious emission(1GHz-18GHz)	U=4.5dB
4	3m chamber Radiated spurious emission(18GHz-40GHz)	U=3.34dB
5	Conducted Emission(150kHz-30MHz)	U=3.20dB
6	Conducted Adjacent channel power	U=1.38dB
7	Conducted output power uncertainty Above 1G	U=1.576dB
8	Conducted output power uncertainty below 1G	U=1.28dB
9	humidity uncertainty	U=5.3%
10	Temperature uncertainty	U=0.59°C

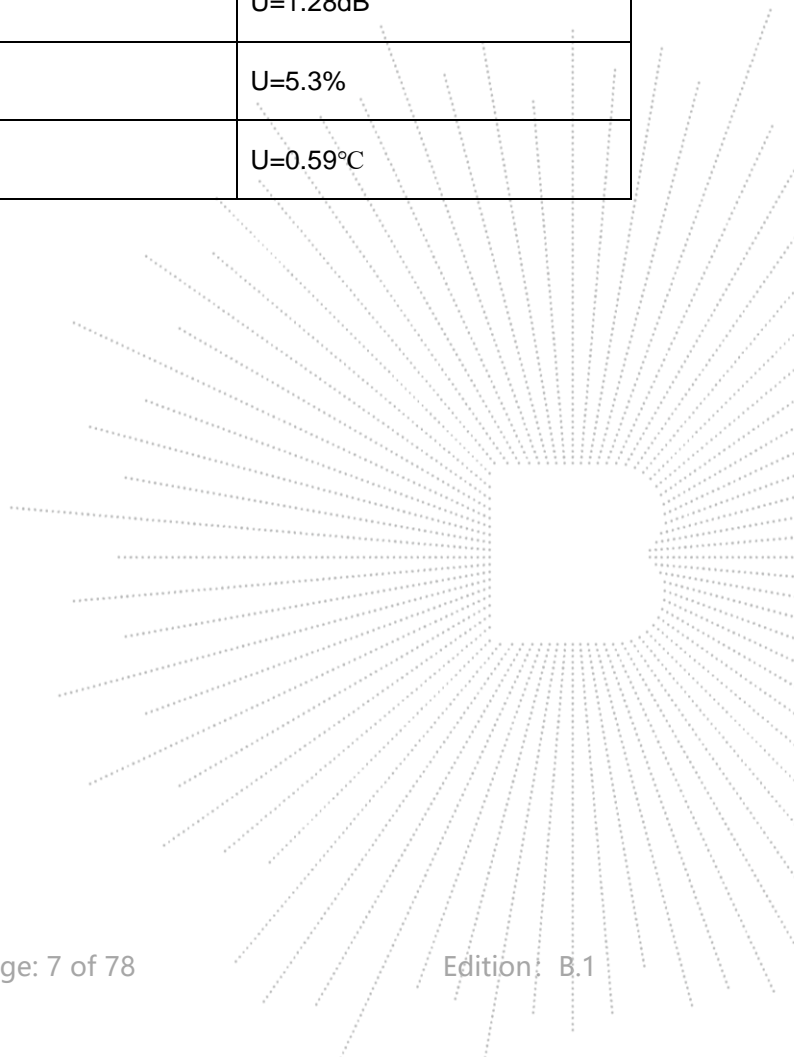

4. Product Information And Test Setup

4.1 Product Information

Model/Type reference:	Reolink Argus 3 Pro Argus Series B330
Model differences:	All the model are the same circuit and RF module, except model names.
Hardware Version:	V1.0
Software Version:	V1.0
IEEE 802.11 WLAN Mode Supported	802.11a/n(20MHz channel bandwidth)
Operation Frequency:	5180-5240MHz for 802.11a/n(HT20); 5745-5825 MHz for 802.11a/n(HT20);
Data Rate	802.11a: 6,9,12,18,24,36,48,54Mbps; 802.11n(HT20/HT40):MCS0-MCS15;
Type of Modulation:	OFDM with BPSK/QPSK/16QAM/64QAM/256QAM for 802.11a/n;
Antenna installation:	Internal antenna 5.1G: 4.35 dBi 5.8G: 4.35 dBi Remark:
Antenna Gain:	<input checked="" type="checkbox"/> The antenna gain of the product comes from the antenna report provided by the customer, and the test data is affected by the customer information. <input type="checkbox"/> The antenna gain of the product is provided by the customer, and the test data is affected by the customer information.
Ratings:	AC120V/60Hz

4.2 Test Setup Configuration

See test photographs attached in *EUT TEST SETUP PHOTOGRAPHS* for the actual connections between Product and support equipment.

Conducted Emission:

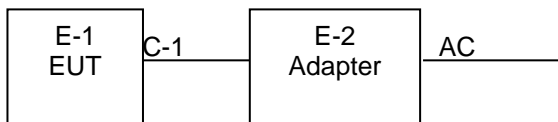

Radiated Spurious Emission

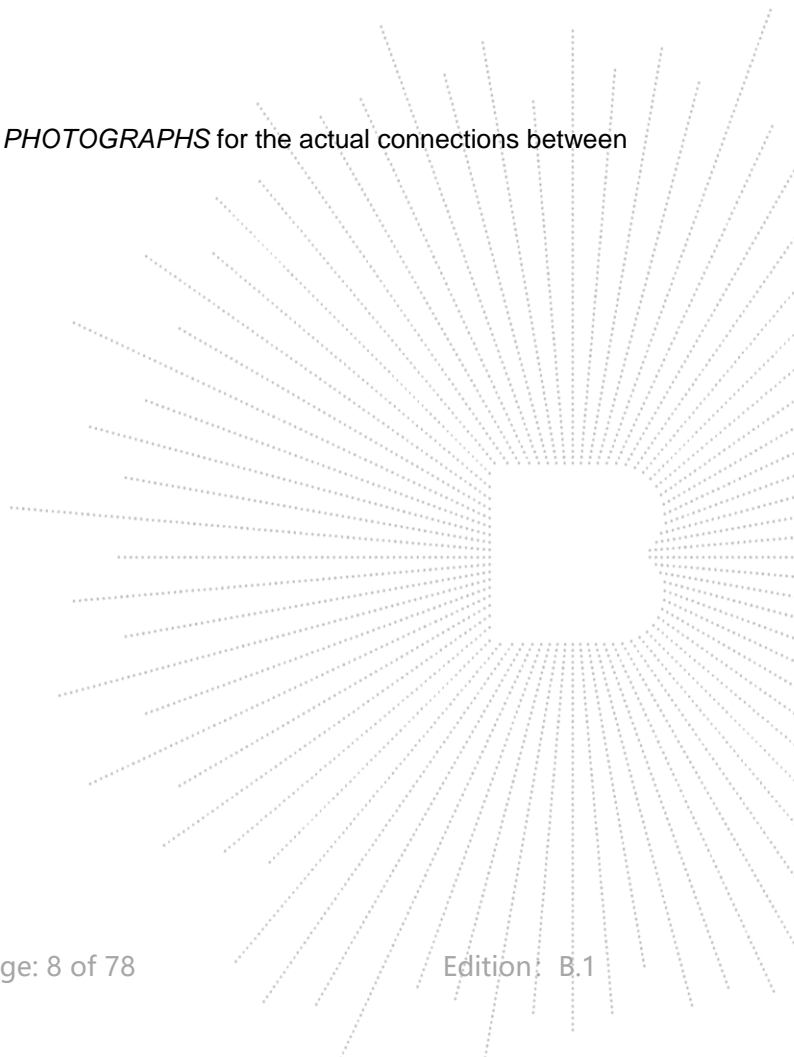
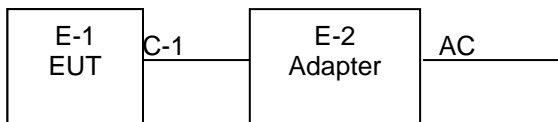

4.3 Support Equipment

No.	Device Type	Brand	Model	Series No.	Note
E-1	WiFi IP Camera		Reolink Argus 3 Pro	N/A	EUT

Item	Shielded Type	Ferrite Core	Length	Note
C-1	N/A	N/A	1M	DC cable unshielded

Notes:

1. All the equipment/cables were placed in the worst-case configuration to maximize the emission during the test.
2. Grounding was established in accordance with the manufacturer's requirements and conditions for the intended use.

4.4 Channel List

(U-NII-1) 5180MHz-5240MHz				
Bandwidth	Channel	Frequency (MHz)	Channel	Frequency (MHz)
20MHz	36	5180	40	5200
	44	5220	48	5240
(U-NII-3) 5745MHz-5825MHz				
Bandwidth	Channel	Frequency (MHz)	Channel	Frequency (MHz)
20MHz	149	5745	153	5765
	157	5785	161	5805
	165	5825		

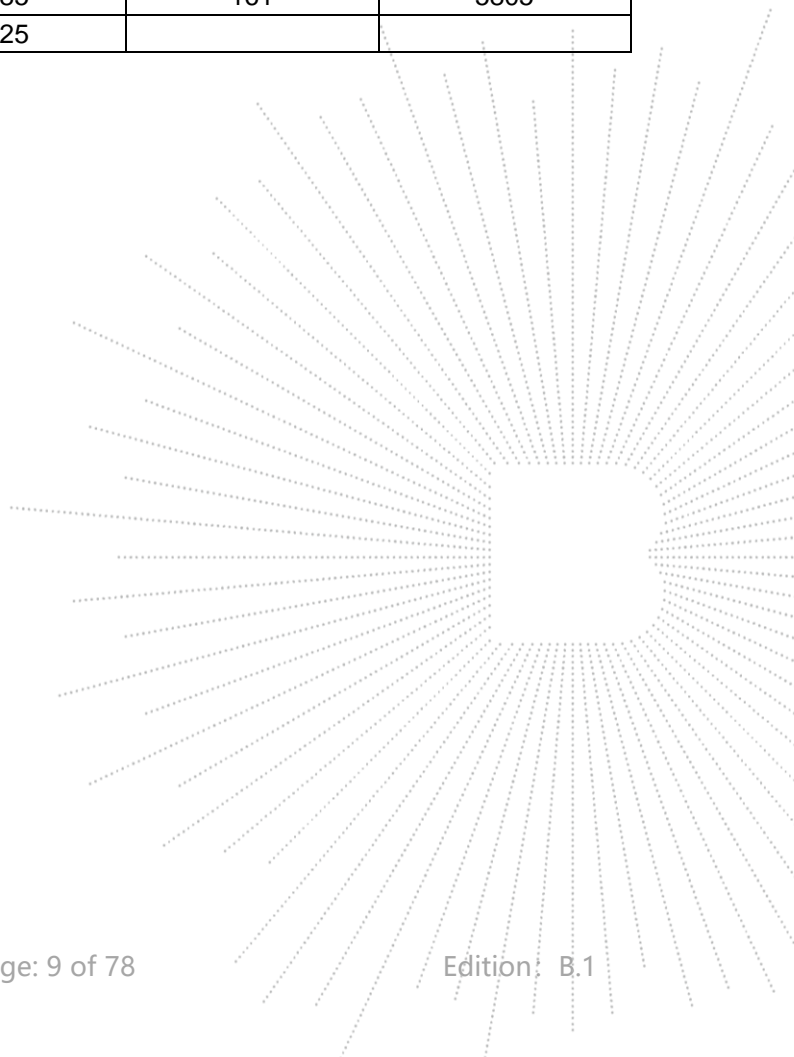

4.5 Test Mode

To investigate the maximum EMI emission characteristics generated from EUT, the test system was pre-scanning tested based on the consideration of following EUT operation mode or test configuration mode which possibly have effect on EMI emission level. Each of these EUT operation mode(s) or test configuration mode(s) mentioned above was evaluated respectively.

Pretest Mode	Description
Mode 1	802.11a / n 20 CH36/ CH40/ CH 48 802.11a / n 20 CH52/ CH56/ CH 64 802.11a / n 20 CH100/ CH116/ CH 140 802.11a / n 20 CH149/ CH157/ CH 165
Mode 2	Link Mode

Note:

(1) The measurements are performed at all Bit Rate of Transmitter, the worst data was reported.

4.6 Table Of Parameters Of Text Software Setting

During testing channel & power controlling software provided by the customer was used to control the operating channel as well as the output power level. The RF output power selection is for the setting of RF output power expected by the customer and is going to be fixed on the firmware of the final end product power parameters

Test software Version	CMD		
Parameters	DEF	DEF	DEF

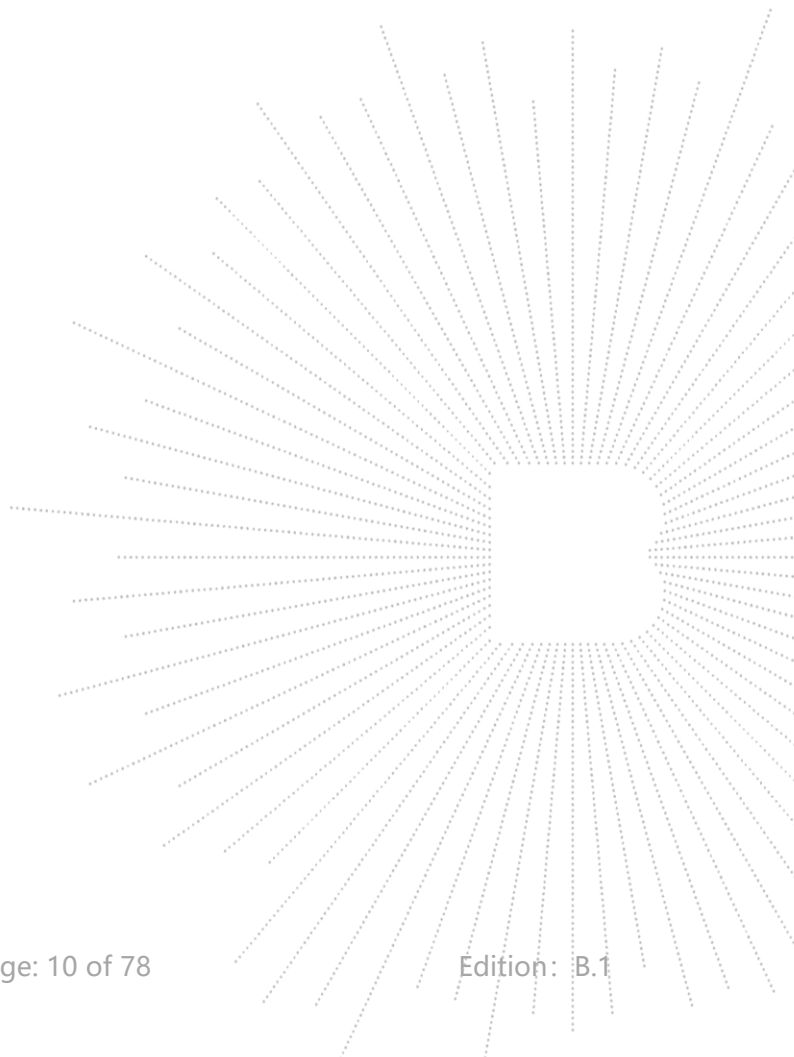

5. Test Facility And Test Instrument Used

5.1 Test Facility

All measurement facilities used to collect the measurement data are located at Shenzhen BCTC Testing Co., Ltd. Address: 1-2/F., Building B, Pengzhou Industrial Park, No.158, Fuyuan 1st Road, Zhancheng, Fuhai Subdistrict, Bao'an District, Shenzhen, Guangdong, China. The site and apparatus are constructed in conformance with the requirements of ANSI C63.4 and CISPR 16-1-1 other equivalent standards.

FCC Test Firm Registration Number: 712850

A2LA certificate registration number is: CN1212

ISED Registered No.: 23583

ISED CAB identifier: CN0017

5.2 Test Instrument Used

Conducted Emissions Test					
Equipment	Manufacturer	Model#	Serial#	Last Cal.	Next Cal.
Receiver	R&S	ESR3	102075	May 15, 2023	May 14, 2024
LISN	R&S	ENV216	101375	May 15, 2023	May 14, 2024
Software	Frad	EZ-EMC	EMC-CON 3A1	\	\
Pulse limiter	Schwarzbeck	VTSD9561-F	01323	Sept. 22, 2023	Sept. 21, 2024

RF Conducted Test					
Equipment	Manufacturer	Model#	Serial#	Last Cal.	Next Cal.
Power meter	Keysight	E4419	\	May 15, 2023	May 14, 2024
Power Sensor (AV)	Keysight	E9300A	\	May 15, 2023	May 14, 2024
Signal Analyzer20kHz-26.5GHz	Keysight	N9020A	MY49100060	May 15, 2023	May 14, 2024
Spectrum Analyzer9kHz-40GHz	R&S	FSP40	100363	May 15, 2023	May 14, 2024
Radio frequency control box	MAIWEI	MW100-RFC B	\	\	\
Software	MAIWEI	MTS 8310	\	\	\

Radiated Emissions Test (966 Chamber01)					
Equipment	Manufacturer	Model#	Serial#	Last Cal.	Next Cal.
966 chamber	ChengYu	966 Room	966	May 15, 2023	May 14, 2026
Receiver	R&S	ESR3	102075	May 15, 2023	May 14, 2024
Receiver	R&S	ESRP	101154	May 15, 2023	May 14, 2024
Amplifier	Schwarzbeck	BBV9744	9744-0037	May 15, 2023	May 14, 2024
TRILOG Broadband Antenna	Schwarzbeck	VULB9163	942	May 29, 2023	May 28, 2024
Loop Antenna(9KHz -30MHz)	Schwarzbeck	FMZB1519B	00014	May 31, 2023	May 30, 2024
Amplifier	SKET	LAPA_01G18 G-45dB	SK2021040901	May 15, 2023	May 14, 2024
Horn Antenna	Schwarzbeck	BBHA9120D	1541	May 31, 2023	May 30, 2024
Amplifier(18G Hz-40GHz)	MITEQ	TTA1840-35-HG	2034381	May 15, 2023	May 14, 2024
Horn Antenna(18G Hz-40GHz)	Schwarzbeck	BBHA9170	00822	May 31, 2023	May 30, 2024
Spectrum Analyzer9kHz-40GHz	R&S	FSP40	100363	May 15, 2023	May 14, 2024
Software	Frad	EZ-EMC	FA-03A2 RE	\	\

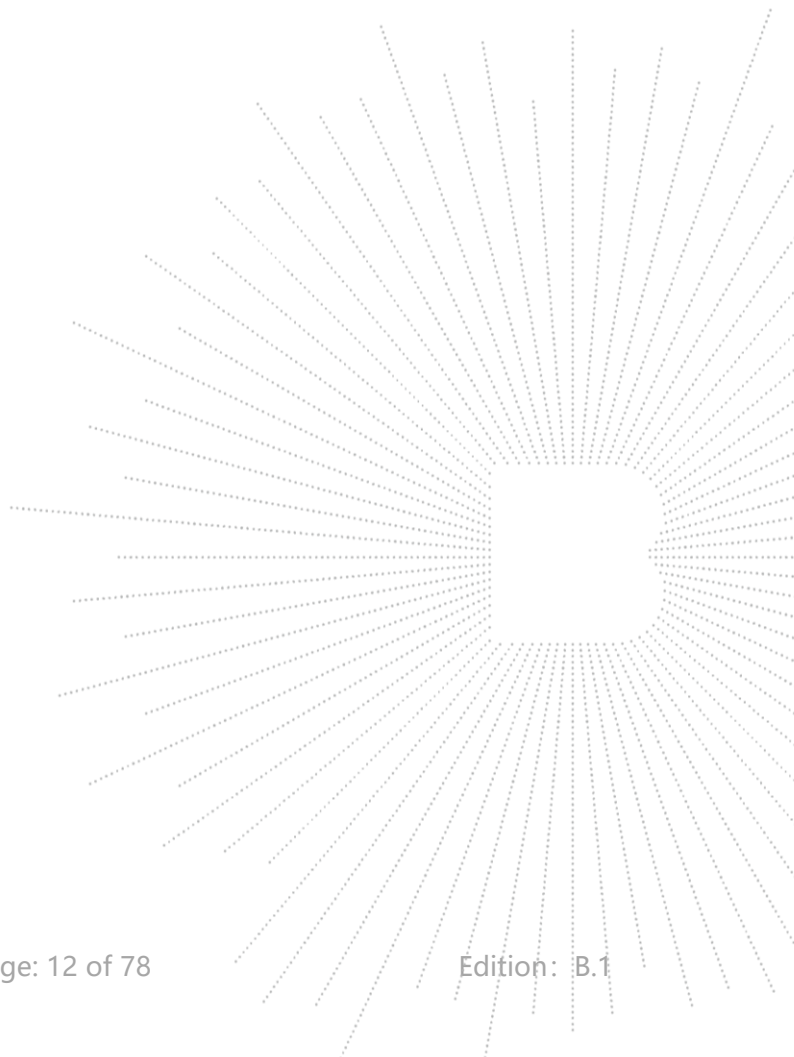

6. Conducted Emissions

6.1 Block Diagram Of Test Setup

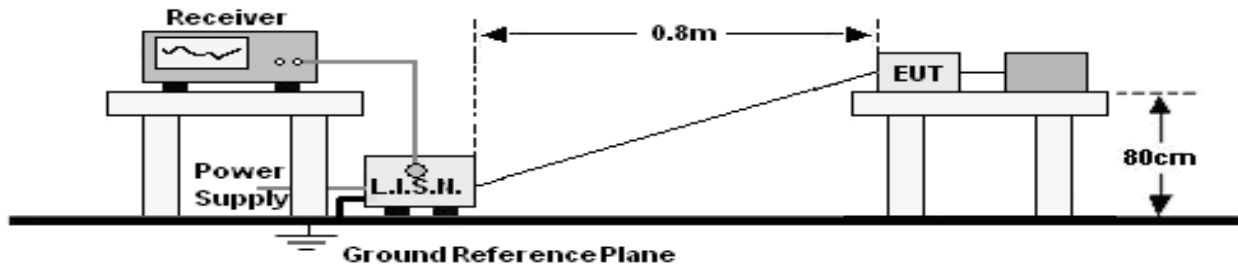

6.2 Limit

Frequency (MHz)	Limit (dBuV)	
	Quas-peak	Average
0.15 -0.5	66 - 56 *	56 - 46 *
0.50 -5.0	56.00	46.00
5.0 -30.0	60.00	50.00

Notes:

- *Decreasing linearly with logarithm of frequency.
- The lower limit shall apply at the transition frequencies.

6.3 Test Procedure

Receiver Parameters	Setting
Attenuation	10 dB
Start Frequency	0.15 MHz
Stop Frequency	30 MHz
IF Bandwidth	9 kHz

- The Product was placed on a nonconductive table 0.8 m above the horizontal ground reference plane, and 0.4 m from the vertical ground reference plane, and connected to the main through Line Impedance Stability Network (L.I.S.N).
- The RBW of the receiver was set at 9 kHz in 150 kHz ~ 30MHz with Peak and AVG detector in Max Hold mode. Run the receiver's pre-scan to record the maximum disturbance generated from Product in all power lines in the full band.
- For each frequency whose maximum record was higher or close to limit, measure its QP and AVG values and record.

6.4 EUT Operating Conditions

The EUT was configured for testing in a typical fashion (as a customer would normally use it). The EUT has been programmed to continuously transmit during test. This operating condition was tested and used to collect the included data.

6.5 Test Result

Temperature:	26 °C	Relative Humidity:	54%
Pressure:	101KPa	Phase :	L
Test Mode:	Mode 2	Test Voltage :	AC120V/60Hz

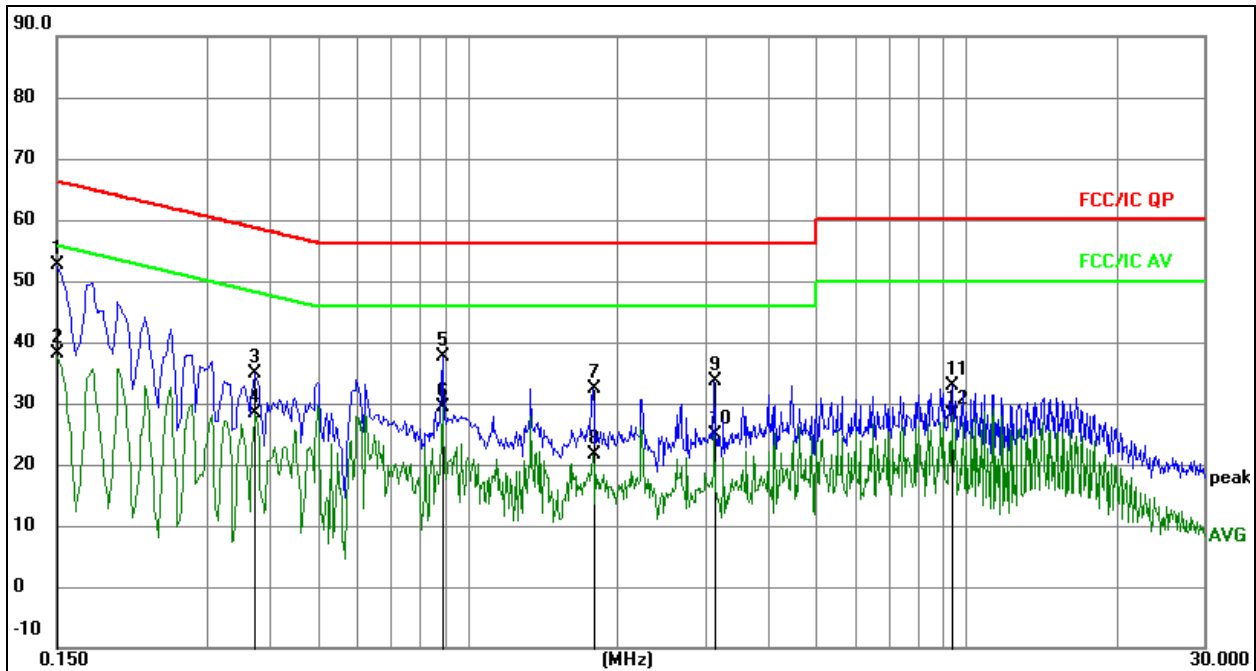

Remark:

1. All readings are Quasi-Peak and Average values.
2. Factor = Insertion Loss + Cable Loss.
3. Measurement=Reading Level+ Correct Factor
4. Over= Measurement-Limit

No.	Mk.	Freq. MHz	Reading Level	Correct Factor dB	Measure- ment dBuV	Limit dBuV	Over dB	Detector
1	*	0.1500	32.99	19.73	52.72	66.00	-13.28	QP
2		0.1500	18.37	19.73	38.10	56.00	-17.90	AVG
3		0.3750	14.93	19.84	34.77	58.39	-23.62	QP
4		0.3750	8.52	19.84	28.36	48.39	-20.03	AVG
5		0.8925	17.72	19.91	37.63	56.00	-18.37	QP
6		0.8925	9.48	19.91	29.39	46.00	-16.61	AVG
7		1.7880	12.37	19.95	32.32	56.00	-23.68	QP
8		1.7880	1.74	19.95	21.69	46.00	-24.31	AVG
9		3.1290	13.20	20.35	33.55	56.00	-22.45	QP
10		3.1290	4.59	20.35	24.94	46.00	-21.06	AVG
11		9.3975	12.86	19.90	32.76	60.00	-27.24	QP
12		9.3975	8.13	19.90	28.03	50.00	-21.97	AVG

Temperature:	26 °C	Relative Humidity:	54%
Pressure:	101KPa	Phase :	N
Test Mode:	Mode 2	Test Voltage :	AC120V/60Hz

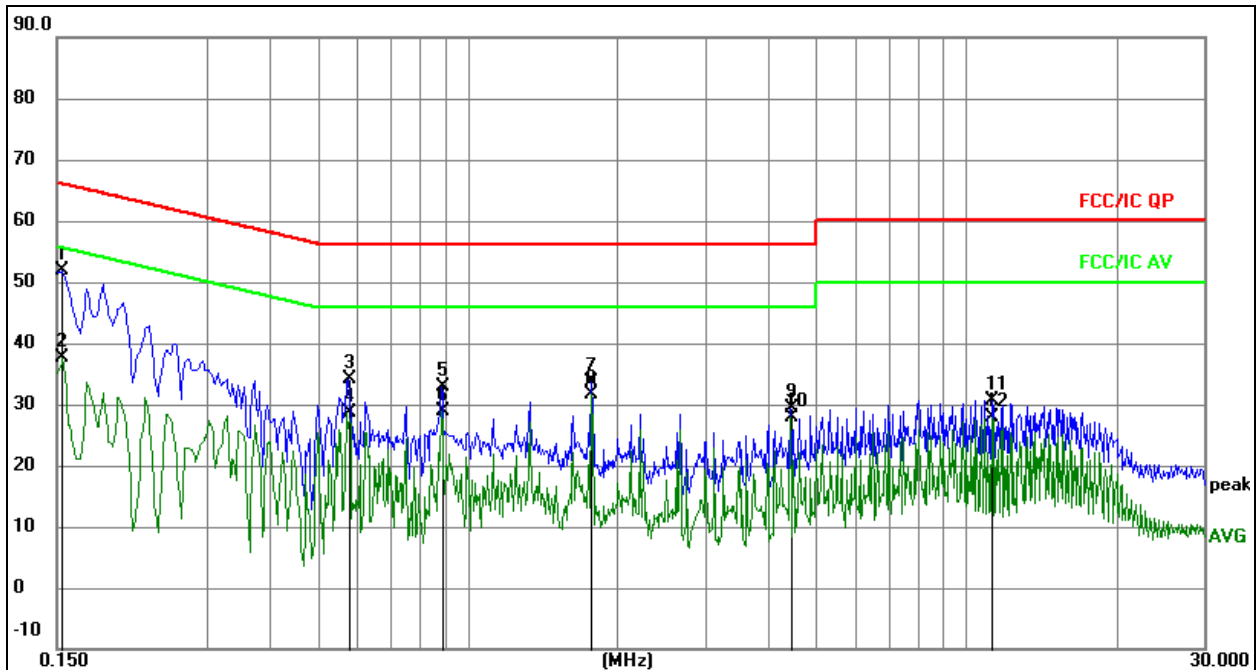
Remark:

1. All readings are Quasi-Peak and Average values.
2. Factor = Insertion Loss + Cable Loss.
3. Measurement=Reading Level+ Correct Factor
4. Over1 Measurement-Limit

No.	Mk.	Freq. MHz	Reading Level	Correct Factor dB	Measure- ment dBuV	Limit dBuV	Over dB	Detector
1	*	0.1539	32.10	19.74	51.84	65.79	-13.95	QP
2		0.1539	17.81	19.74	37.55	55.79	-18.24	AVG
3		0.5762	14.33	19.84	34.17	56.00	-21.83	QP
4		0.5762	8.68	19.84	28.52	46.00	-17.48	AVG
5		0.8850	13.03	19.91	32.94	56.00	-23.06	QP
6		0.8850	8.86	19.91	28.77	46.00	-17.23	AVG
7		1.7716	13.60	19.95	33.55	56.00	-22.45	QP
8		1.7716	11.79	19.95	31.74	46.00	-14.26	AVG
9		4.4305	8.93	20.56	29.49	56.00	-26.51	QP
10		4.4305	7.39	20.56	27.95	46.00	-18.05	AVG
11		11.2572	10.78	19.88	30.66	60.00	-29.34	QP
12		11.2572	7.91	19.88	27.79	50.00	-22.21	AVG

7. Radiated Emissions

7.1 Block Diagram Of Test Setup

(A) Radiated Emission Test-Up Frequency Below 30MHz

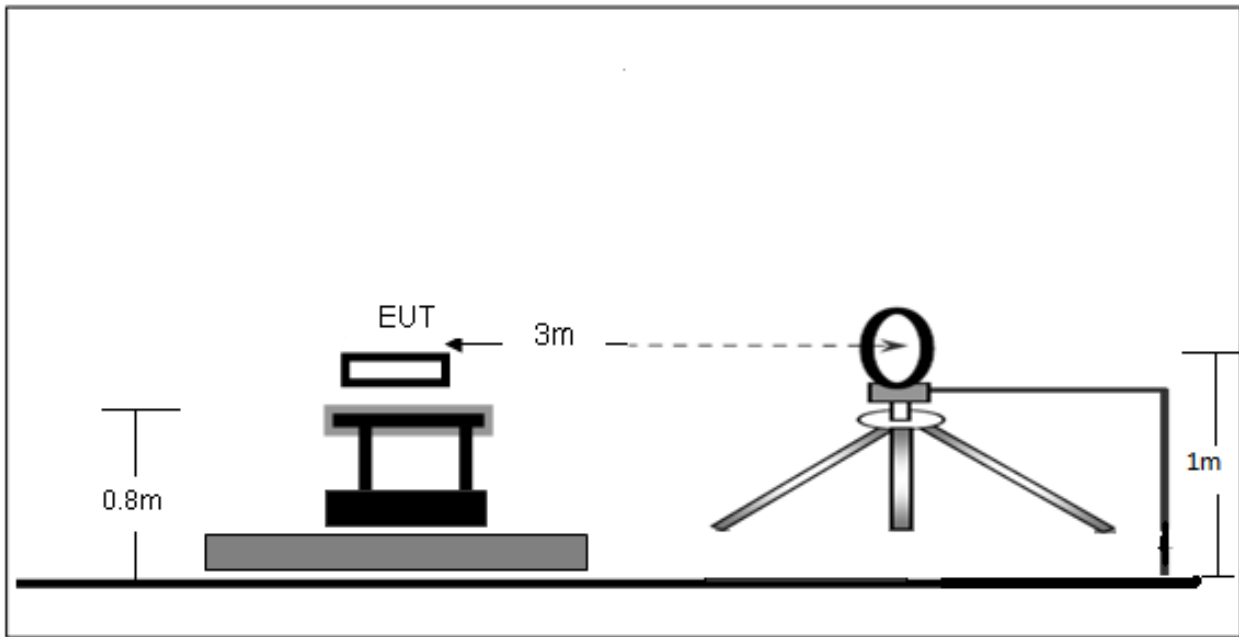

(B) Radiated Emission Test-Up Frequency 30MHz~1GHz

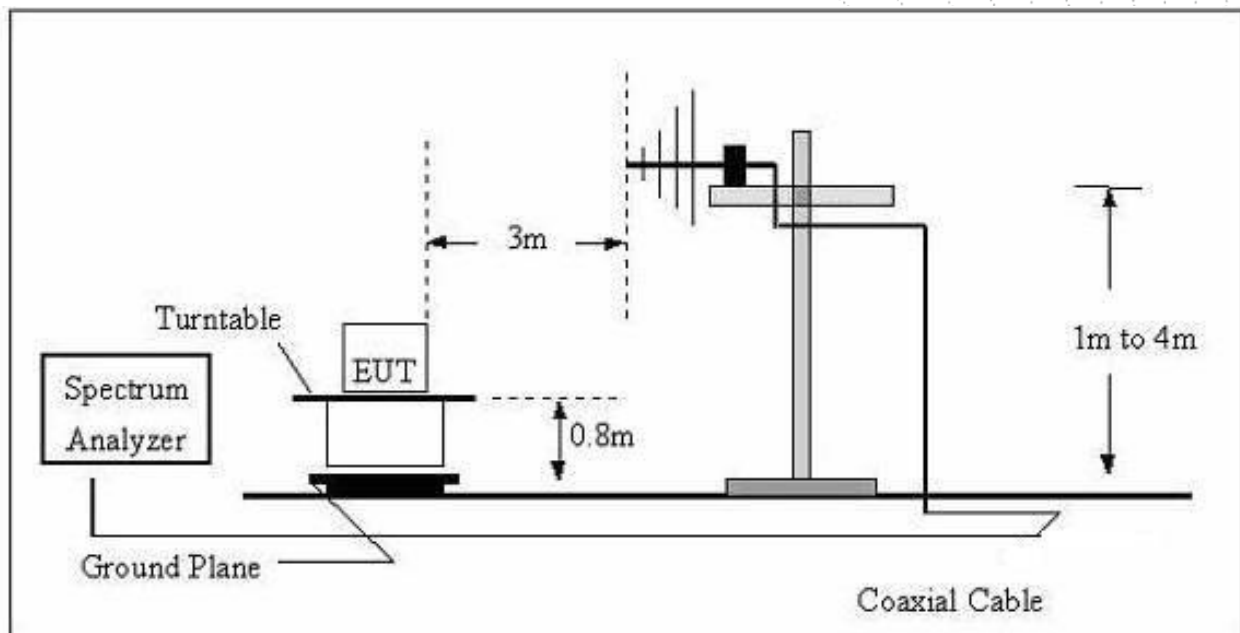

(C) Radiated Emission Test-Up Frequency Above 1GHz



7.2 Limit

20dBc in any 100 kHz bandwidth outside the operating frequency band. In case the emission fall within the restricted band specified on 15.205(a), then the 15.209(a) limit in the table below has to be followed.

Frequency (MHz)	Field Strength uV/m	Distance (m)	Field Strength Limit at 3m Distance	
			uV/m	dBuV/m
0.009 ~ 0.490	2400/F(kHz)	300	10000 * 2400/F(kHz)	20log ^{(2400/F(kHz))} + 80
0.490 ~ 1.705	24000/F(kHz)	30	100 * 24000/F(kHz)	20log ^{(24000/F(kHz))} + 40
1.705 ~ 30	30	30	100 * 30	20log ⁽³⁰⁾ + 40
30 ~ 88	100	3	100	20log ⁽¹⁰⁰⁾
88 ~ 216	150	3	150	20log ⁽¹⁵⁰⁾
216 ~ 960	200	3	200	20log ⁽²⁰⁰⁾
Above 960	500	3	500	20log ⁽⁵⁰⁰⁾

Limits Of Radiated Emission Measurement (Above 1000MHz)

Frequency (MHz)	Limit (dBuV/m) (at 3M)	
	Peak	Average
Above 1000	74	54

Notes:

- (1)The limit for radiated test was performed according to FCC PART 15C.
- (2)The tighter limit applies at the band edges.
- (3) Emission level (dBuV/m)=20log Emission level (uV/m).

7.3 Test Procedure

The test site semi-anechoic chamber has met the requirement of NSA tolerance 4 dB according to the standards: ANSI C63.10-2013. The test distance is 3m. The setup is according to the requirements in Section 13.1.4.1 of ANSI C63.10-2013 and CAN/CSA-CEI/IEC CISPR 22.

This test is required for any spurious emission that falls in a Restricted Band, as defined in Section 15.205. It must be performed with the highest gain of each type of antenna proposed for use with the EUT.

Use the following spectrum analyzer settings:

Spectrum Parameter	Setting
Attenuation	Auto
Start Frequency	1000 MHz
Stop Frequency	10th carrier harmonic
RB / VB (emission in restricted band)	1 MHz / 1 MHz for Peak, 1 MHz / 10Hz for Average

Receiver Parameter	Setting
Attenuation	Auto
Start ~ Stop Frequency	9kHz~150kHz / RB 200Hz for QP
Start ~ Stop Frequency	150kHz~30MHz / RB 9kHz for QP
Start ~ Stop Frequency	30MHz~1000MHz / RB 120kHz for QP

- The measuring distance of at 3 m shall be used for measurements at frequency up to 1GHz. For frequencies above 1GHz, any suitable measuring distance may be used.
- The EUT was placed on the top of a rotating table 0.8 m for below 1GHz and 1.5m for above 1GHz the ground at a 3 meter. The table was rotated 360 degrees to determine the position of the highest radiation.
- The height of the equipment or of the substitution antenna shall be 0.8 m for below 1GHz and 1.5m for above 1GHz; the height of the test antenna shall vary between 1 m to 4 m. Both horizontal and vertical polarizations of the antenna are set to make the measurement.
- The initial step in collecting conducted emission data is a spectrum analyzer peak detector mode pre-scanning the measurement frequency range. Significant peaks are then marked and then Quasi Peak detector mode re-measured.
- If the Peak Mode measured value compliance with and lower than Quasi Peak Mode Limit, the EUT shall be deemed to meet QP Limits and then no additional QP Mode measurement performed.
- For the actual test configuration, please refer to the related Item –EUT Test Photos.

Note:

Both horizontal and vertical antenna polarities were tested and performed pretest to three orthogonal axis. The worst case emissions were reported

During the radiated emission test, the Spectrum Analyzer was set with the following configurations:

Frequency Band (MHz)	Function	Resolution bandwidth	Video Bandwidth
30 to 1000	QP	120 kHz	300 kHz
Above 1000	Peak	1 MHz	1 MHz
	Average	1 MHz	10 Hz

Note: for the frequency ranges below 30 MHz, a narrower RBW is used for these ranges but the measured value should add a RBW correction factor (RBWCF) where $RBWCF [dB] = 10 \cdot \lg(100 [kHz] / \text{narrower RBW} [kHz])$. , the narrower RBW is 1 kHz and RBWCF is 20 dB for the frequency 9 kHz to 150 kHz, and the narrower RBW is 10 kHz and RBWCF is 10 dB for the frequency 150 kHz to 30 MHz.

7.4 EUT Operating Conditions

The EUT was configured for testing in a typical fashion (as a customer would normally use it). The EUT has been programmed to continuously transmit during test. This operating condition was tested and used to collect the included data.

7.5 Test Result

Below 30MHz

Temperature:	26°C	Relative Humidity:	54%
Pressure:	101 kPa	Test Voltage:	AC120V/60Hz
Test Mode:	Mode 2	Polarization:	--

Freq. (MHz)	Reading (dBuV/m)	Limit (dBuV/m)	Margin (dB)	State P/F
--	--	--	--	PASS
--	--	--	--	PASS

Note:

The amplitude of spurious emissions which are attenuated by more than 20dB below the permissible value has no need to be reported.

Distance extrapolation factor = $40 \log(\text{specific distance/test distance})(\text{dB})$;

Limit line = specific limits(dBuv) + distance extrapolation factor.

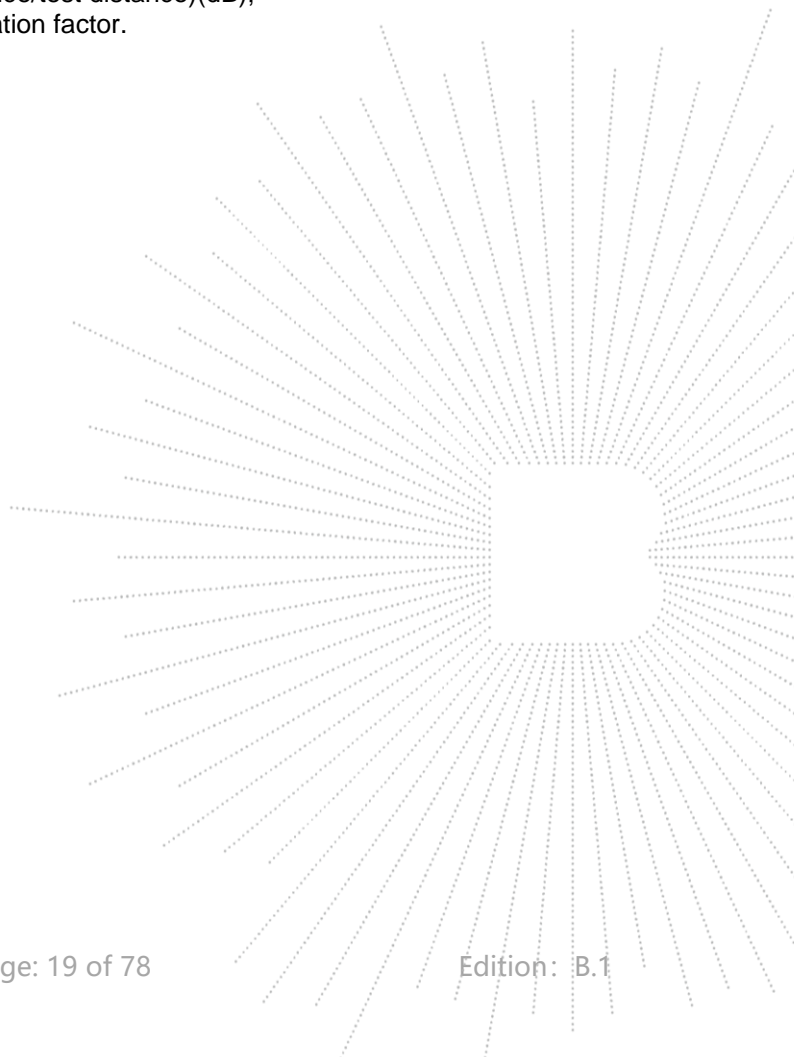

Between 30MHz – 1GHz

Temperature:	26 °C	Relative Humidity:	54%
Pressure:	101KPa	Phase :	Horizontal
Test Mode:	Mode 2	Test Voltage :	AC120V/60Hz

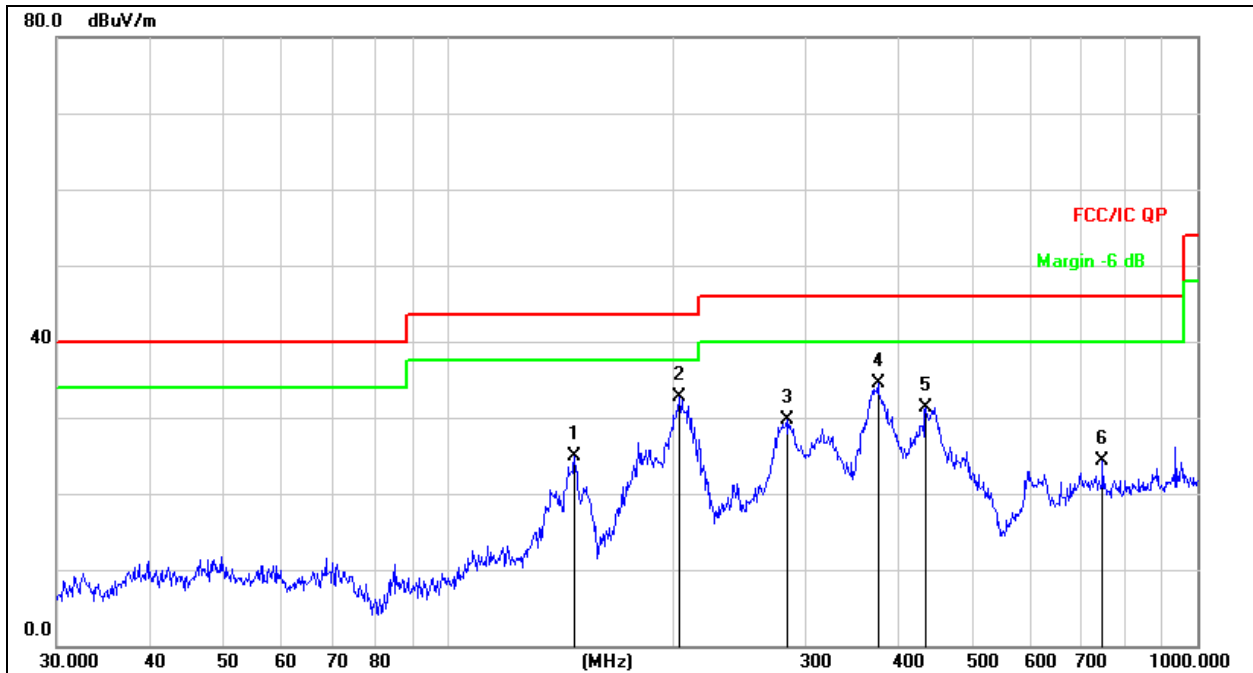

Remark:
 1. Factor = Antenna Factor + Cable Loss – Pre-amplifier.
 2. Measurement=Reading Level+ Correct Factor
 3. Over=Measurement-Limit

No.	Mk.	Freq. MHz	Reading Level dBuV	Correct Factor dB	Measure- ment dBuV/m	Limit dB/m	Over dB	Detector
1		147.4036	44.06	-19.25	24.81	43.50	-18.69	QP
2	*	203.5228	48.34	-15.62	32.72	43.50	-10.78	QP
3		282.9852	43.25	-13.60	29.65	46.00	-16.35	QP
4		374.6225	45.71	-11.16	34.55	46.00	-11.45	QP
5		434.0651	41.53	-10.17	31.36	46.00	-14.64	QP
6		747.4825	29.29	-5.03	24.26	46.00	-21.74	QP

Temperature:	26 °C	Relative Humidity:	54%
Pressure:	101KPa	Phase :	Vertical
Test Mode:	Mode 2	Test Voltage :	AC120V/60Hz

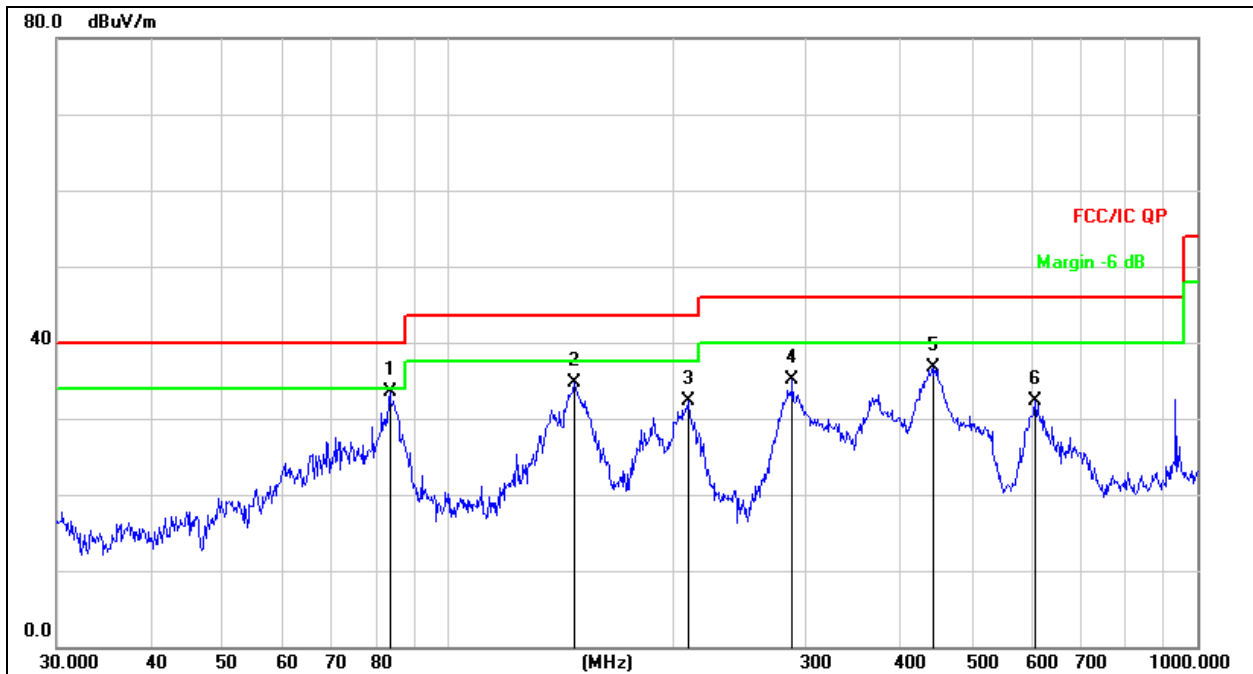

Remark:

1. Factor = Antenna Factor + Cable Loss – Pre-amplifier.
2. Measurement=Reading Level+ Correct Factor
3. Over= Measurement-Limit

No.	Mk.	Freq. MHz	Reading Level dBuV	Correct Factor dB	Measure- ment dBuV/m	Limit dB/m	Over dB	Detector
1	*	83.5222	52.34	-18.92	33.42	40.00	-6.58	QP
2		147.4036	53.97	-19.25	34.72	43.50	-8.78	QP
3		209.3129	47.80	-15.45	32.35	43.50	-11.15	QP
4		287.9904	48.59	-13.49	35.10	46.00	-10.90	QP
5		443.2943	46.75	-9.99	36.76	46.00	-9.24	QP
6		607.7867	39.26	-6.89	32.37	46.00	-13.63	QP

Between 1GHz – 40GHz(The worst case)

Test Mode:	TX(5.1G) - 802.11a
------------	--------------------

Polar (H/V)	Frequency (MHz)	Reading Level (dBuV/m)	Correct Factor (dB)	Measurement (dBuV/m)	Limits (dBuV/m)	Over (dB)	Detector Type
Low Channel (5180 MHz)-Above 1G							
Vertical	4434.15	72.57	-20.73	51.83	68.20	-16.37	PK
Vertical	4434.15	59.65	-20.73	38.92	54.00	-15.08	AV
Vertical	10360.06	63.93	-9.36	54.57	68.20	-13.63	PK
Vertical	10360.06	49.99	-9.36	40.63	54.00	-13.37	AV
Vertical	15540.00	64.36	-7.84	56.52	74.00	-17.48	PK
Vertical	15540.00	49.98	-7.84	42.14	54.00	-11.86	AV
Horizontal	4434.11	73.09	-20.73	52.36	68.20	-15.84	PK
Horizontal	4434.11	59.50	-20.73	38.77	54.00	-15.23	AV
Horizontal	10360.09	64.99	-9.36	55.63	68.20	-12.57	PK
Horizontal	10360.09	49.68	-9.36	40.32	54.00	-13.68	AV
Horizontal	15540.15	63.24	-7.84	55.40	74.00	-18.60	PK
Horizontal	15540.15	49.33	-7.84	41.49	54.00	-12.51	AV
Middle Channel (5200 MHz)-Above 1G							
Vertical	4592.12	70.04	-20.42	49.63	74.00	-24.37	PK
Vertical	4592.12	59.79	-20.42	39.37	54.00	-14.63	AV
Vertical	10400.13	61.60	-9.30	52.30	68.20	-15.90	PK
Vertical	10400.13	49.48	-9.30	40.18	54.00	-13.82	AV
Vertical	15600.01	60.52	-7.82	52.70	74.00	-21.30	PK
Vertical	15600.01	49.25	-7.82	41.43	54.00	-12.57	AV
Horizontal	4592.07	72.31	-20.42	51.90	74.00	-22.10	PK
Horizontal	4592.07	59.56	-20.42	39.15	54.00	-14.85	AV
Horizontal	10400.03	63.11	-9.30	53.81	68.20	-14.39	PK
Horizontal	10400.03	49.71	-9.30	40.41	54.00	-13.59	AV
Horizontal	15600.11	60.25	-7.82	52.43	74.00	-21.57	PK
Horizontal	15600.11	49.52	-7.82	41.70	54.00	-12.30	AV
High Channel (5240 MHz)-Above 1G							
Vertical	4739.18	73.16	-20.12	53.03	74.00	-20.97	PK
Vertical	4739.18	59.97	-20.12	39.85	54.00	-14.15	AV
Vertical	10480.03	61.83	-9.18	52.65	68.20	-15.55	PK
Vertical	10480.03	49.11	-9.18	39.93	54.00	-14.07	AV
Vertical	15720.01	61.98	-7.78	54.20	74.00	-19.80	PK
Vertical	15720.01	49.63	-7.78	41.85	54.00	-12.15	AV
Horizontal	4739.08	72.42	-20.12	52.30	74.00	-21.70	PK
Horizontal	4739.08	59.15	-20.12	39.02	54.00	-14.98	AV
Horizontal	10480.17	61.93	-9.18	52.75	68.20	-15.45	PK
Horizontal	10480.17	49.40	-9.18	40.22	54.00	-13.78	AV
Horizontal	15720.14	63.69	-7.78	55.91	74.00	-18.09	PK
Horizontal	15720.14	49.51	-7.78	41.73	54.00	-12.27	AV

Note: PK value is lower than the Average value limit, So average didn't record.
 The 26.5-40G amplitude of spurious emissions that are attenuated by more than 20dB below the permissible value has no need to be reported.

Emission level (dBuV/m) = 20 log Emission level (uV/m).

Corrected Reading: Antenna Factor + Cable Loss + Read Level - Preamp Factor = Level.

Test Mode:	TX(5.1G) - 802.11n-HT20
------------	-------------------------

Polar	Frequency	Reading Level	Correct Factor	Measurement	Limits	Over	Detector Type
(H/V)	(MHz)	(dBuV/m)	(dB)	(dBuV/m)	(dBuV/m)	(dB)	
Low Channel (5180 MHz)-Above 1G							
Vertical	4434.06	70.63	-20.73	49.90	68.20	-18.30	PK
Vertical	4434.06	59.87	-20.73	39.14	54.00	-14.86	AV
Vertical	10360.07	63.48	-9.36	54.12	68.20	-14.08	PK
Vertical	10360.07	49.28	-9.36	39.92	54.00	-14.08	AV
Vertical	15540.03	61.85	-7.84	54.01	74.00	-19.99	PK
Vertical	15540.03	49.23	-7.84	41.39	54.00	-12.61	AV
Horizontal	4434.13	73.42	-20.73	52.69	68.20	-15.51	PK
Horizontal	4434.13	59.78	-20.73	39.04	54.00	-14.96	AV
Horizontal	10360.19	64.24	-9.36	54.88	68.20	-13.32	PK
Horizontal	10360.19	49.38	-9.36	40.02	54.00	-13.98	AV
Horizontal	15540.19	61.73	-7.84	53.89	74.00	-20.11	PK
Horizontal	15540.19	49.64	-7.84	41.80	54.00	-12.20	AV
Middle Channel (5200 MHz)-Above 1G							
Vertical	4592.00	72.00	-20.42	51.59	74.00	-22.41	PK
Vertical	4592.00	59.19	-20.42	38.77	54.00	-15.23	AV
Vertical	10400.12	62.91	-9.30	53.61	68.20	-14.59	PK
Vertical	10400.12	49.18	-9.30	39.88	54.00	-14.12	AV
Vertical	15600.03	60.08	-7.82	52.26	74.00	-21.74	PK
Vertical	15600.03	49.75	-7.82	41.93	54.00	-12.07	AV
Horizontal	4592.17	74.54	-20.42	54.13	74.00	-19.87	PK
Horizontal	4592.17	59.16	-20.42	38.74	54.00	-15.26	AV
Horizontal	10400.16	60.59	-9.30	51.29	68.20	-16.91	PK
Horizontal	10400.16	49.11	-9.30	39.81	54.00	-14.19	AV
Horizontal	15600.10	63.73	-7.82	55.91	74.00	-18.09	PK
Horizontal	15600.10	49.62	-7.82	41.80	54.00	-12.20	AV
High Channel (5240 MHz)-Above 1G							
Vertical	4739.13	71.75	-20.12	51.62	74.00	-22.38	PK
Vertical	4739.13	59.16	-20.12	39.03	54.00	-14.97	AV
Vertical	10480.04	64.39	-9.18	55.21	68.20	-12.99	PK
Vertical	10480.04	49.35	-9.18	40.17	54.00	-13.83	AV
Vertical	15720.16	64.82	-7.78	57.04	74.00	-16.96	PK
Vertical	15720.16	49.08	-7.78	41.30	54.00	-12.70	AV
Horizontal	4739.15	74.98	-20.12	54.86	74.00	-19.14	PK
Horizontal	4739.15	59.16	-20.12	39.04	54.00	-14.96	AV
Horizontal	10480.18	64.56	-9.18	55.38	68.20	-12.82	PK
Horizontal	10480.18	49.33	-9.18	40.15	54.00	-13.85	AV
Horizontal	15720.15	61.56	-7.78	53.78	74.00	-20.22	PK
Horizontal	15720.15	49.25	-7.78	41.47	54.00	-12.53	AV

Note: PK value is lower than the Average value limit, So average didn't record.

The 26.5-40G amplitude of spurious emissions that are attenuated by more than 20dB below the permissible value has no need to be reported.

Emission level (dBuV/m) = 20 log Emission level (uV/m).

Corrected Reading: Antenna Factor + Cable Loss + Read Level - Preamp Factor = Level.

Test Mode:	TX (5.8G) -- 802.11a
------------	----------------------

Polar	Frequency	Reading Level	Correct Factor	Measurement	Limits	Over	Detector Type
(H/V)	(MHz)	(dBuV/m)	(dB)	(dBuV/m)	(dBuV/m)	(dB)	
Low Channel (5745 MHz)-Above 1G							
Vertical	4679.07	73.79	-20.24	53.55	74.00	-20.45	PK
Vertical	4679.07	59.32	-20.24	39.08	54.00	-14.92	AV
Vertical	11490.17	62.41	-8.79	53.62	68.20	-14.58	PK
Vertical	11490.17	49.23	-8.79	40.44	54.00	-13.56	AV
Vertical	17235.16	56.82	-3.18	53.64	68.20	-14.56	PK
Vertical	17235.16	44.04	-3.18	40.86	54.00	-13.14	AV
Horizontal	4679.18	72.70	-20.73	51.97	74.00	-22.03	PK
Horizontal	4679.18	59.63	-20.73	38.90	54.00	-15.10	AV
Horizontal	11490.10	62.44	-8.79	53.65	68.20	-14.55	PK
Horizontal	11490.10	49.80	-8.79	41.01	54.00	-12.99	AV
Horizontal	17235.11	55.42	-3.18	52.24	68.20	-15.96	PK
Horizontal	17235.11	44.34	-3.18	41.16	54.00	-12.84	AV
Middle Channel (5785 MHz)-Above 1G							
Vertical	4592.13	71.19	-20.42	50.77	74.00	-23.23	PK
Vertical	4592.13	59.23	-20.42	38.81	54.00	-15.19	AV
Vertical	11570.01	61.86	-8.86	53.00	68.20	-15.20	PK
Vertical	11570.01	49.04	-8.86	40.18	54.00	-13.82	AV
Vertical	17355.18	55.16	-2.52	52.64	68.20	-15.56	PK
Vertical	17355.18	44.73	-2.52	42.21	54.00	-11.79	AV
Horizontal	4592.16	70.44	-20.42	50.03	74.00	-23.97	PK
Horizontal	4592.16	59.58	-20.42	39.16	54.00	-14.84	AV
Horizontal	11570.15	61.94	-8.86	53.08	68.20	-15.12	PK
Horizontal	11570.15	49.88	-8.86	41.02	54.00	-12.98	AV
Horizontal	17355.19	55.15	-2.52	52.63	68.20	-15.57	PK
Horizontal	17355.19	44.56	-2.52	42.04	54.00	-11.96	AV
High Channel (5825 MHz)-Above 1G							
Vertical	6039.02	72.88	-18.93	53.95	68.20	-14.25	PK
Vertical	6039.02	59.05	-18.93	40.12	54.00	-13.88	AV
Vertical	11650.17	63.85	-8.92	54.93	74.00	-19.07	PK
Vertical	11650.17	49.64	-8.92	40.72	54.00	-13.28	AV
Vertical	17475.04	59.61	-1.86	57.75	68.20	-10.45	PK
Vertical	17475.04	44.50	-1.86	42.64	54.00	-11.36	AV
Horizontal	6039.03	72.35	-18.93	53.42	68.20	-14.78	PK
Horizontal	6039.03	59.67	-18.93	40.74	54.00	-13.26	AV
Horizontal	11650.03	64.20	-8.92	55.28	74.00	-18.72	PK
Horizontal	11650.03	49.16	-8.92	40.24	54.00	-13.76	AV
Horizontal	17475.15	56.99	-1.86	55.13	68.20	-13.07	PK
Horizontal	17475.15	44.80	-1.86	42.94	54.00	-11.06	AV

Note: PK value is lower than the Average value limit, So average didn't record.
 The 26.5-40G amplitude of spurious emissions that are attenuated by more than 20dB below the permissible value has no need to be reported.
 Emission level (dBuV/m) = 20 log Emission level (uV/m).
 Corrected Reading: Antenna Factor + Cable Loss + Read Level - Preamp Factor = Level.

Test Mode:	TX (5.8G) --802.11n-HT20
------------	--------------------------

Polar	Frequency	Reading Level	Correct Factor	Measurement	Limits	Over	Detector Type
(H/V)	(MHz)	(dBuV/m)	(dB)	(dBuV/m)	(dBuV/m)	(dB)	
Low Channel (5745 MHz)-Above 1G							
Vertical	4679.18	72.47	-20.24	52.22	74.00	-21.78	PK
Vertical	4679.18	59.44	-20.24	39.20	54.00	-14.80	AV
Vertical	11490.13	64.52	-8.79	55.73	68.20	-12.47	PK
Vertical	11490.13	49.08	-8.79	40.29	54.00	-13.71	AV
Vertical	17235.19	55.29	-3.18	52.11	68.20	-16.09	PK
Vertical	17235.19	44.70	-3.18	41.52	54.00	-12.48	AV
Horizontal	4679.13	73.97	-20.24	53.73	74.00	-20.27	PK
Horizontal	4679.13	59.53	-20.24	39.29	54.00	-14.71	AV
Horizontal	11490.12	63.78	-8.79	54.99	68.20	-13.21	PK
Horizontal	11490.12	49.34	-8.79	40.55	54.00	-13.45	AV
Horizontal	17235.03	55.02	-3.18	51.84	68.20	-16.36	PK
Horizontal	17235.03	44.56	-3.18	41.38	54.00	-12.62	AV
Middle Channel (5785 MHz)-Above 1G							
Vertical	4592.03	71.92	-20.42	51.50	74.00	-22.50	PK
Vertical	4592.03	59.89	-20.42	39.47	54.00	-14.53	AV
Vertical	11570.09	63.80	-8.86	54.94	68.20	-13.26	PK
Vertical	11570.09	49.04	-8.86	40.18	54.00	-13.82	AV
Vertical	17355.14	57.29	-2.52	54.77	68.20	-13.43	PK
Vertical	17355.14	44.91	-2.52	42.39	54.00	-11.61	AV
Horizontal	4592.00	73.47	-20.42	53.06	74.00	-20.94	PK
Horizontal	4592.00	59.00	-20.42	38.58	54.00	-15.42	AV
Horizontal	11570.16	61.90	-8.86	53.04	68.20	-15.16	PK
Horizontal	11570.16	49.29	-8.86	40.43	54.00	-13.57	AV
Horizontal	17355.01	56.85	-2.52	54.33	68.20	-13.87	PK
Horizontal	17355.01	44.93	-2.52	42.41	54.00	-11.59	AV
High Channel (5825 MHz)-Above 1G							
Vertical	6039.15	71.58	-18.93	52.65	68.20	-15.55	PK
Vertical	6039.15	59.27	-18.93	40.34	54.00	-13.66	AV
Vertical	11650.03	62.10	-8.92	53.18	74.00	-20.82	PK
Vertical	11650.03	49.85	-8.92	40.93	54.00	-13.07	AV
Vertical	17475.07	57.32	-1.86	55.46	68.20	-12.74	PK
Vertical	17475.07	44.29	-1.86	42.43	54.00	-11.57	AV
Horizontal	6039.20	72.11	-18.93	53.17	68.20	-15.03	PK
Horizontal	6039.20	59.66	-18.93	40.73	54.00	-13.27	AV
Horizontal	11650.16	63.11	-8.92	54.19	74.00	-19.81	PK
Horizontal	11650.16	49.54	-8.92	40.62	54.00	-13.38	AV
Horizontal	17475.11	59.45	-1.86	57.59	68.20	-10.61	PK
Horizontal	17475.11	44.33	-1.86	42.47	54.00	-11.53	AV

Note: PK value is lower than the Average value limit, So average didn't record.
 The 26.5-40G amplitude of spurious emissions that are attenuated by more than 20dB below the permissible value has no need to be reported.
 Emission level (dBuV/m) = 20 log Emission level (uV/m).
 Corrected Reading: Antenna Factor + Cable Loss + Read Level - Preamp Factor = Level.

8. Power Spectral Density Test

8.1 Block Diagram Of Test Setup



8.2 Limit

For the band 5.15-5.25 GHz,

(i) For an outdoor access point operating in the band 5.15-5.25 GHz, the maximum power spectral density shall not exceed 17 dBm in any 1 megahertz band. If transmitting antennas of directional gain greater than 6 dBi are used, both the maximum conducted output power and the maximum power spectral density shall be reduced by the amount in dB that the directional gain of the antenna exceeds 6 dBi. The maximum e.i.r.p. at any elevation angle above 30 degrees as measured from the horizon must not exceed 125 mW (21 dBm).

(ii) For an indoor access point operating in the band 5.15-5.25 GHz, the maximum power spectral density shall not exceed 17 dBm in any 1 megahertz band. If transmitting antennas of directional gain greater than 6 dBi are used, both the maximum conducted output power and the maximum power spectral density shall be reduced by the amount in dB that the directional gain of the antenna exceeds 6 dBi.

(iii) For fixed point-to-point access points operating in the band 5.15-5.25 GHz, the maximum power spectral density shall not exceed 17 dBm in any 1 megahertz band. Fixed point-to-point U-NII devices may employ antennas with directional gain up to 23 dBi without any corresponding reduction in the maximum conducted output power or maximum power spectral density. For fixed point-to-point transmitters that employ a directional antenna gain greater than 23 dBi, a 1 dB reduction in maximum conducted output power and maximum power spectral density is required for each 1 dB of antenna gain in excess of 23 dBi. Fixed, point-to-point operations exclude the use of point-to-multipoint systems, omnidirectional applications, and multiple collocated transmitters transmitting the same information. The operator of the U-NII device, or if the equipment is professionally installed, the installer, is responsible for ensuring that systems employing high gain directional antennas are used exclusively for fixed, point-to-point operations.

(iv) For client devices in the 5.15-5.25 GHz band, the maximum power spectral density shall not exceed 11 dBm in any 1 megahertz band. If transmitting antennas of directional gain greater than 6 dBi are used, both the maximum conducted output power and the maximum power spectral density shall be reduced by the amount in dB that the directional gain of the antenna exceeds 6 dBi.

For the band 5.725-5.85 GHz

(3) For the band 5.725-5.85 GHz, the maximum power spectral density shall not exceed 30 dBm in any 500-kHz band. If transmitting antennas of directional gain greater than 6 dBi are used, both the maximum conducted output power and the maximum power spectral density shall be reduced by the amount in dB that the directional gain of the antenna exceeds 6 dBi.

8.3 Test Procedure

For devices operating in the bands 5.15-5.25 GHz, 5.25-5.35 GHz, and 5.47-5.725 GHz, the above procedures make use of 1 MHz RBW to satisfy directly the 1 MHz reference bandwidth specified in § 15.407(a)(5). For devices operating in the band 5.725-5.85 GHz, the rules specify a measurement bandwidth of 500 kHz. Many spectrum analyzers do not have 500 kHz RBW, thus a narrower RBW may need to be used. The rules permit the use of a RBWs less than 1 MHz, or 500 kHz, “provided that the measured power is integrated over the full reference bandwidth” to show the total power over the specified measurement bandwidth (i.e., 1 MHz, or 500 kHz). If measurements are performed using a reduced resolution bandwidth (< 1 MHz, or < 500 kHz) and integrated over 1 MHz, or 500 KHz bandwidth, the following adjustments to the procedures apply:

- a) Set $RBW \geq 1/T$, where T is defined in section II.B.I.a).
- b) Set $VBW \geq 3 RBW$.
- c) If measurement bandwidth of Maximum PSD is specified in 500 kHz, add $10\log(500\text{kHz}/RBW)$ to the measured result, whereas RBW (< 500 KHz) is the reduced resolution bandwidth of the spectrum analyzer set during measurement.
- d) If measurement bandwidth of Maximum PSD is specified in 1 MHz, add $10\log(1\text{MHz}/RBW)$ to the measured result, whereas RBW (< 1 MHz) is the reduced resolution bandwidth of spectrum analyzer set during measurement.
- e) Care must be taken to ensure that the measurements are performed during a period of continuous transmission or are corrected upward for duty cycle.

Note: As a practical matter, it is recommended to use reduced RBW of 100 kHz for the sections 5.c) and 5.d) above, since RBW=100 KHZ is available on nearly all spectrum analyzers.

8.4 EUT Operating Conditions

The EUT was configured for testing in a typical fashion (as a customer would normally use it). The EUT has been programmed to continuously transmit during test. This operating condition was tested and used to collect the included data.

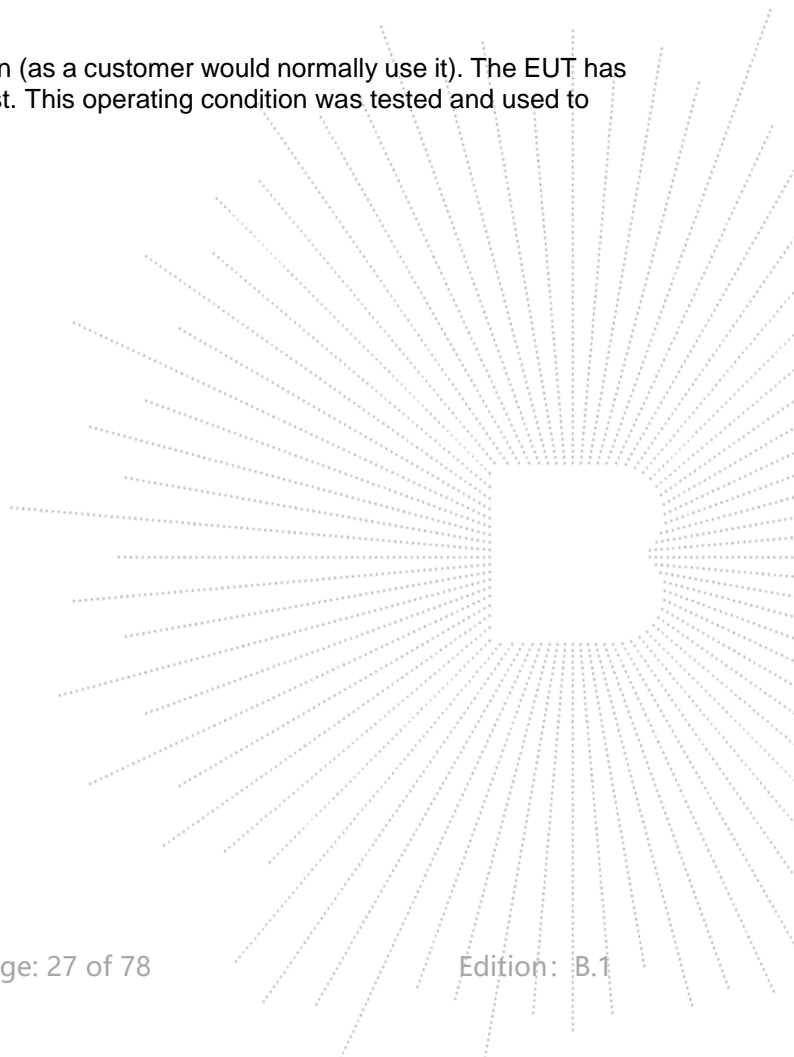

8.5 Test Result

Temperature:	26 °C	Relative Humidity:	54%
Pressure:	101KPa	Test Voltage:	AC 120V/60Hz
Test Mode:	(5180-5240MHz)		

Condition	Mode	Frequency (MHz)	Conducted PSD (dBm/MHz)	Limit (dBm/MHz)	Verdict
NVNT	a	5180	2.23	11	Pass
NVNT	a	5200	1.4	11	Pass
NVNT	a	5240	0.63	11	Pass
NVNT	n20	5180	1.23	11	Pass
NVNT	n20	5200	0.95	11	Pass
NVNT	n20	5240	0.64	11	Pass

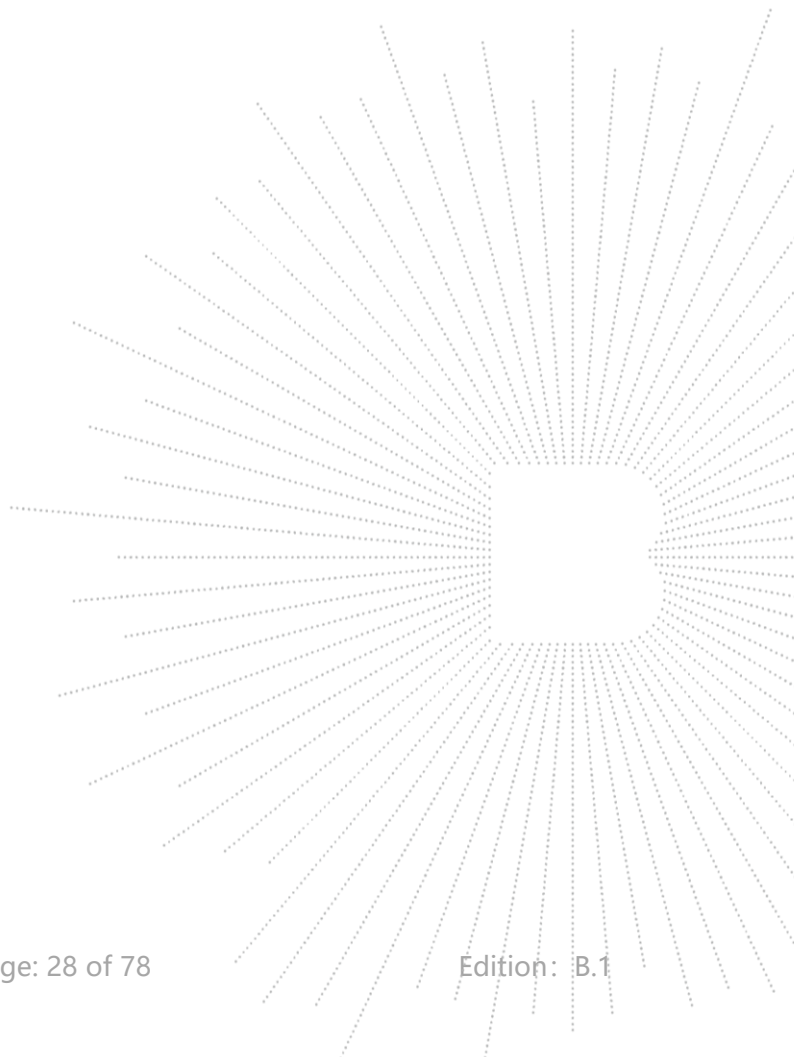

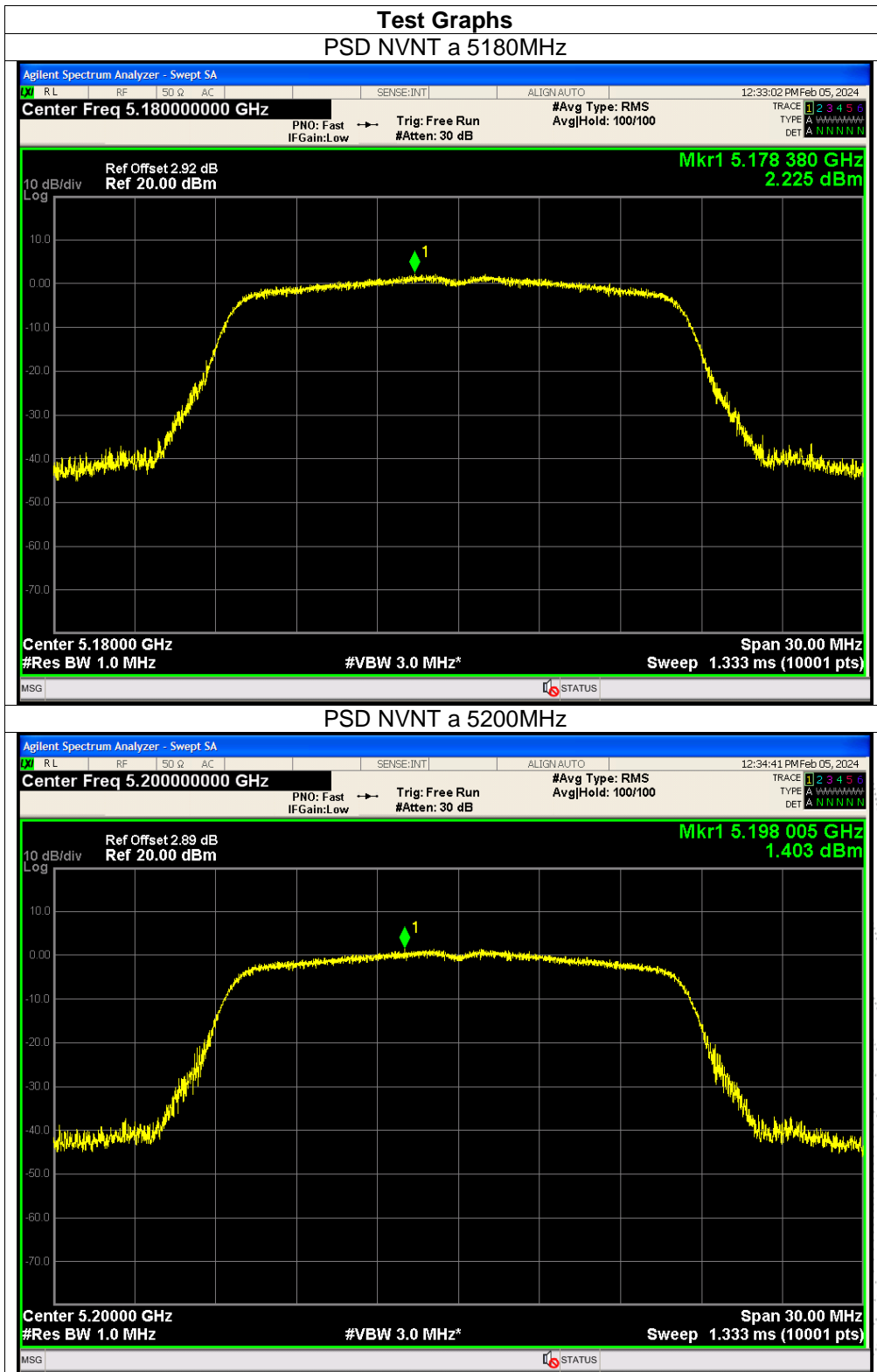

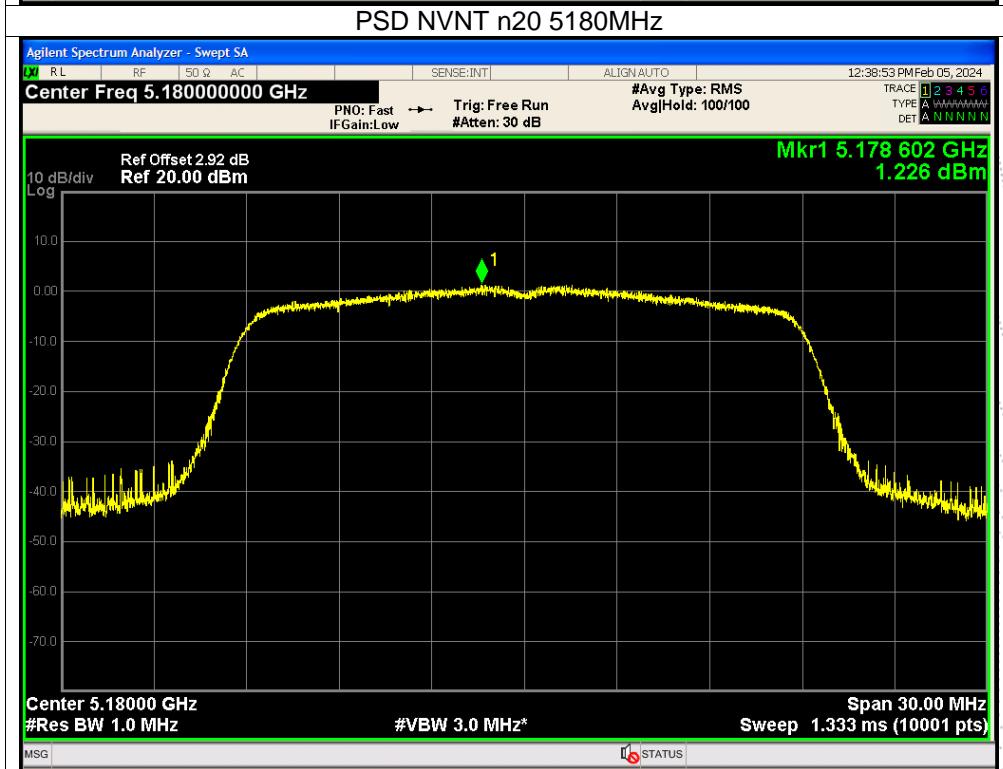
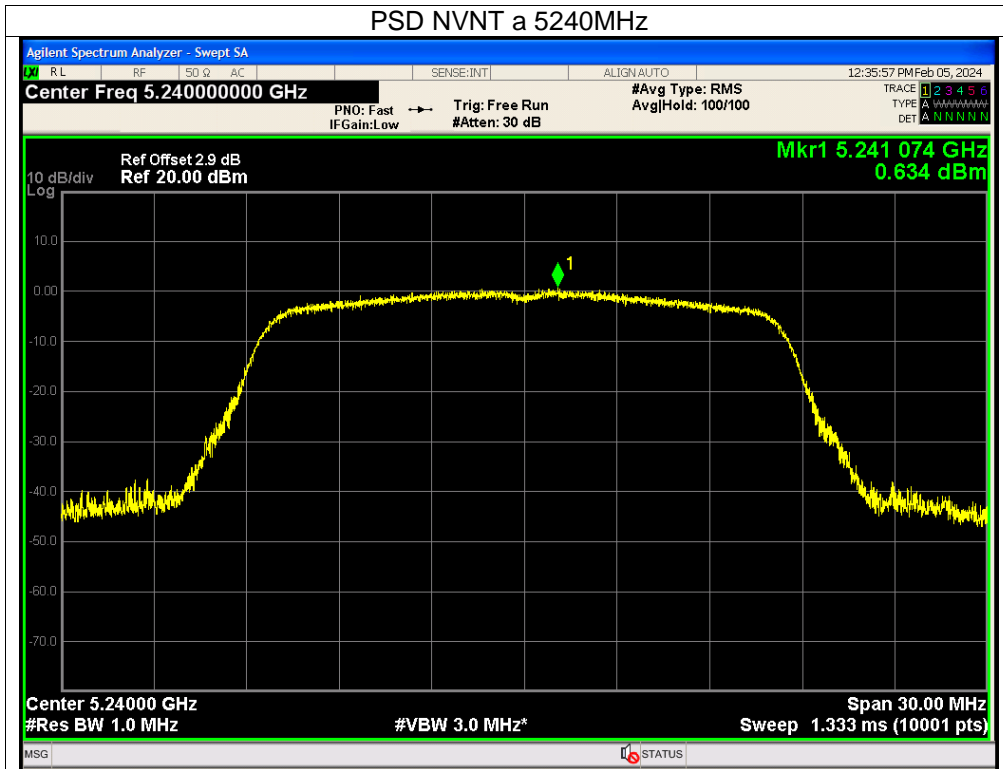

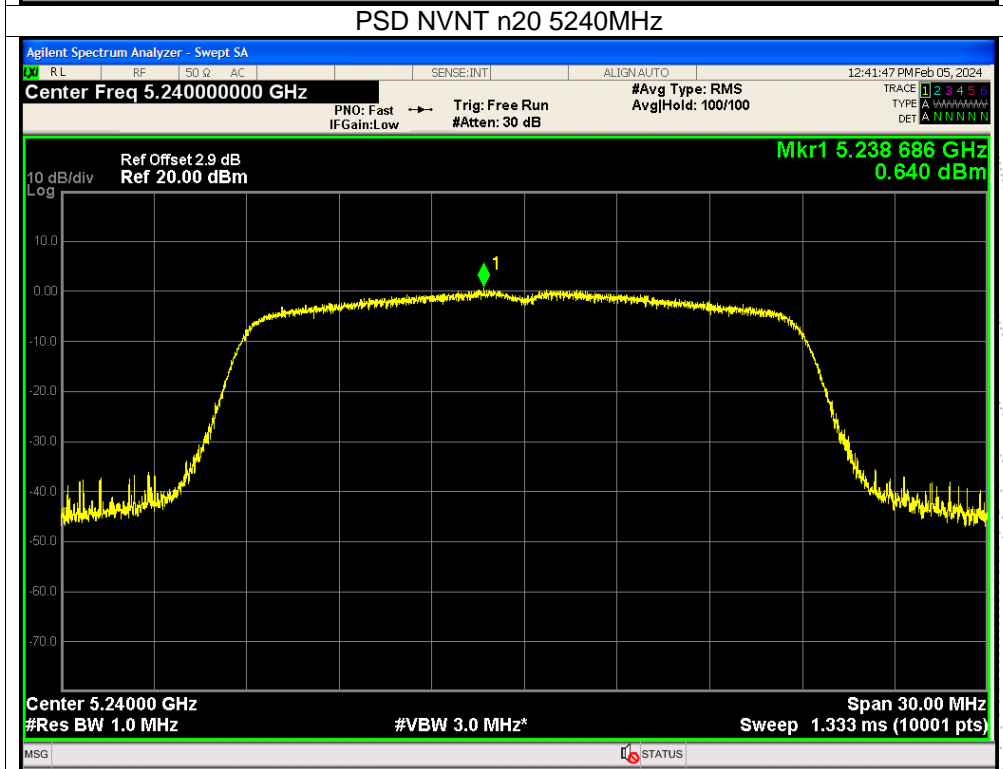
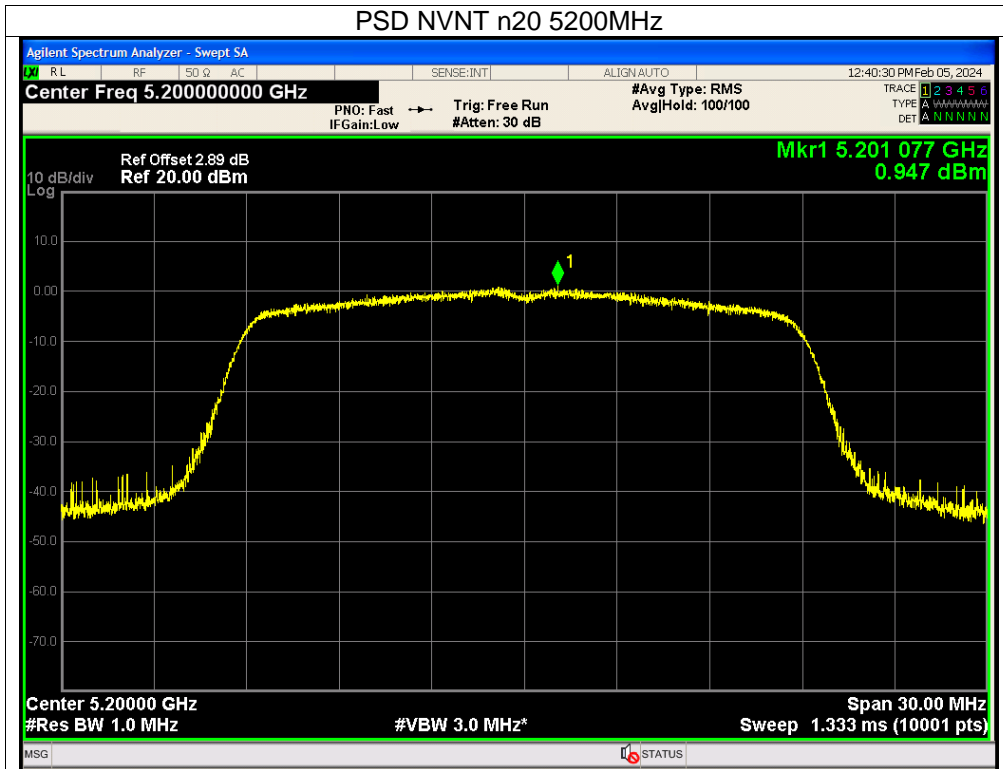

Temperature:	26 °C	Relative Humidity:	54%
Pressure:	101KPa	Test Voltage:	AC 120V/60Hz
Test Mode:	(5745-5825MHz)		

Condition	Mode	Frequency (MHz)	Conducted PSD (dBm/510KHz)	Conducted PSD (dBm/500KHz)	Limit (dBm/500KHz)	Verdict
NVNT	a	5745	-1.65	-1.736	30	Pass
NVNT	a	5785	-1.71	-1.796	30	Pass
NVNT	a	5825	-0.97	-1.056	30	Pass
NVNT	n20	5745	-2.76	-2.846	30	Pass
NVNT	n20	5785	-2.93	-3.016	30	Pass
NVNT	n20	5825	-2.22	-2.306	30	Pass

Note: Correction Factor = $10\log(500\text{KHz}/\text{RBW in measurement}) = -0.086$

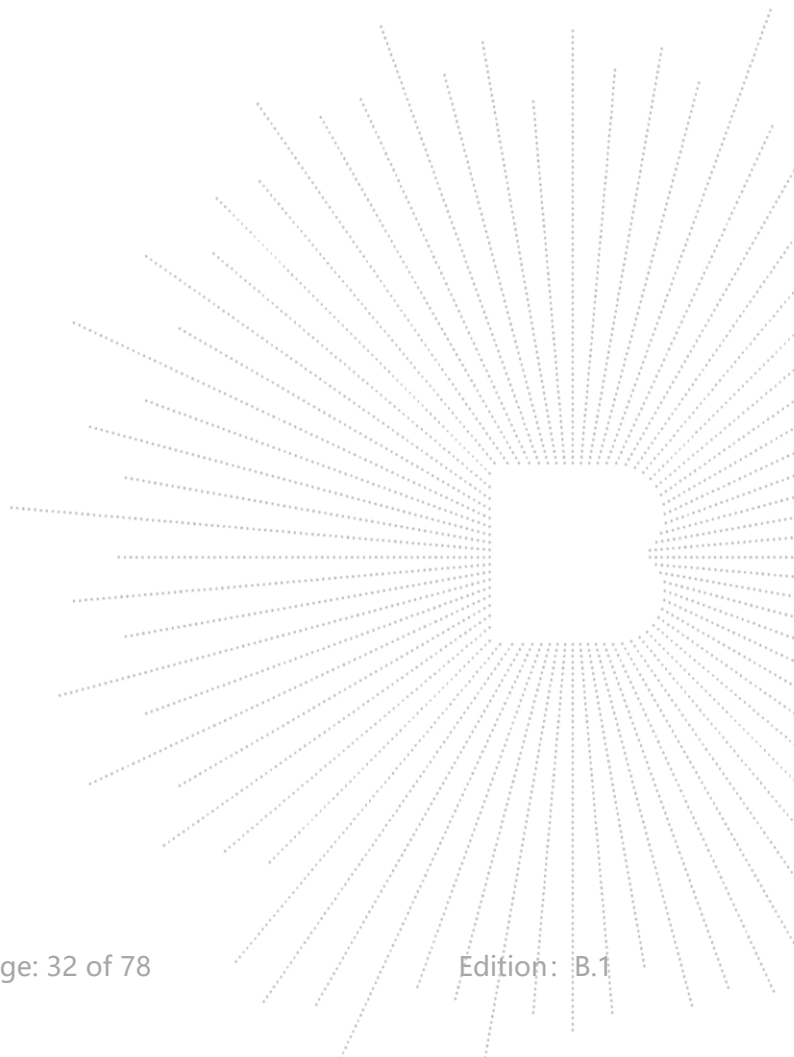

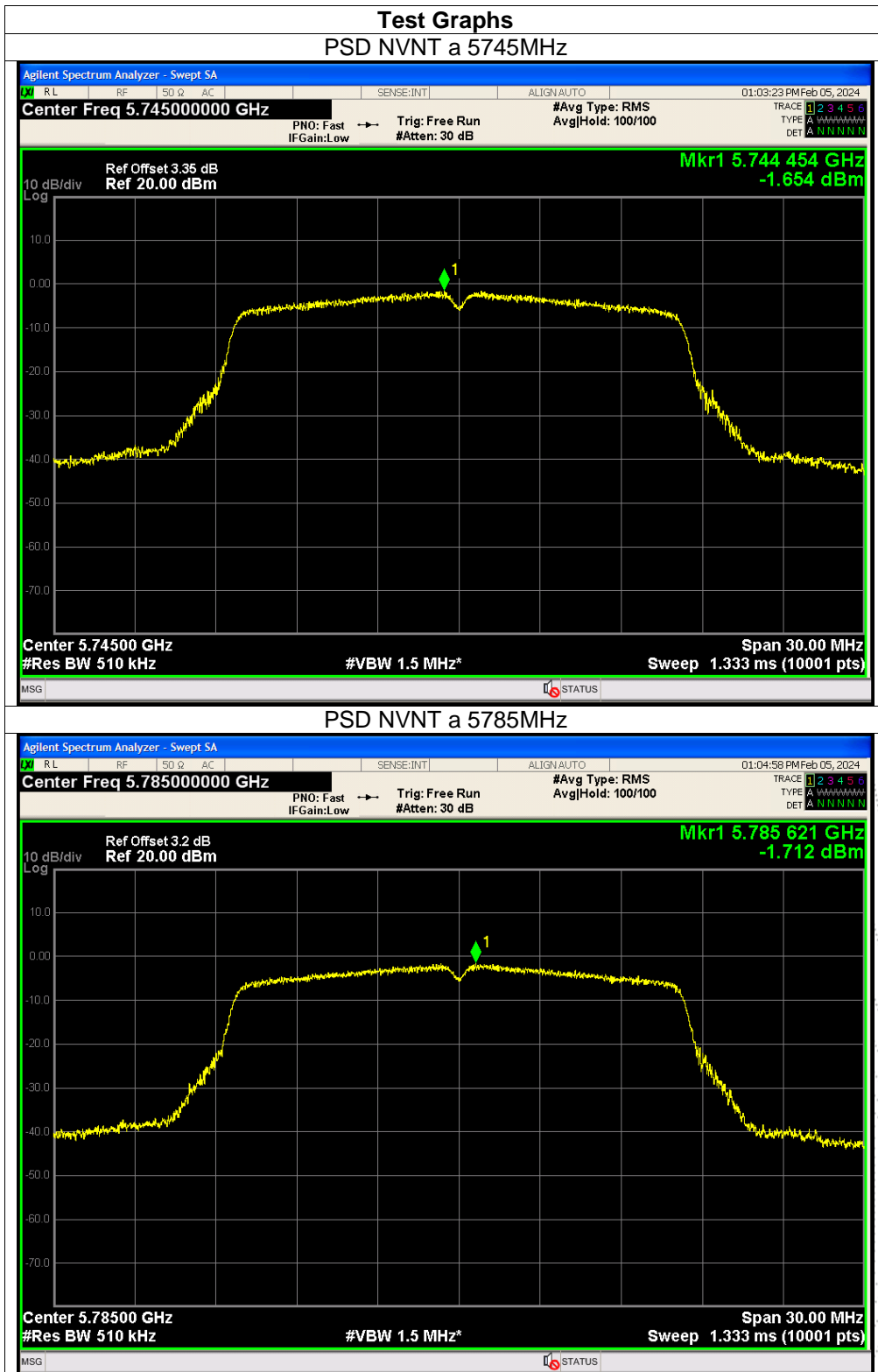

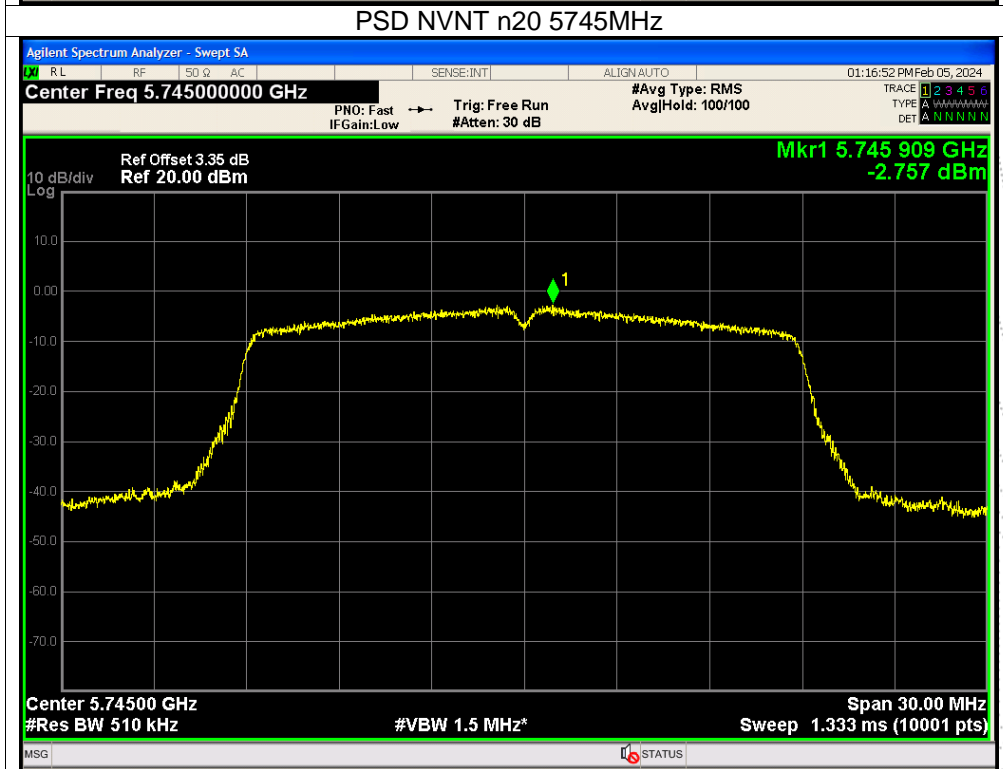
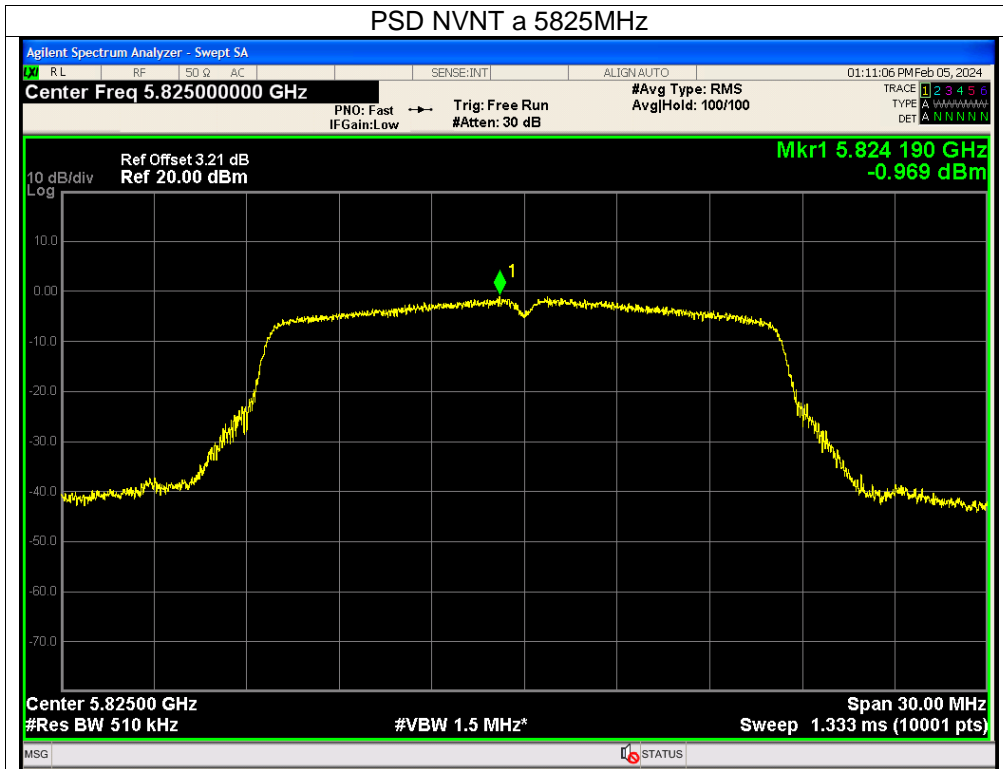

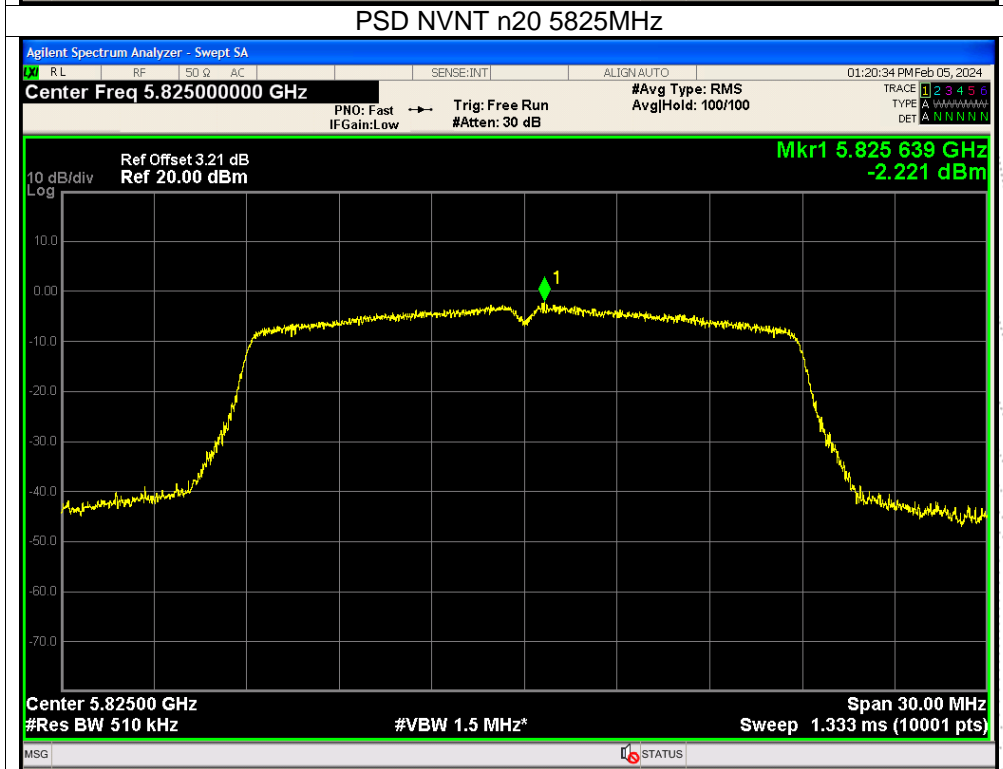
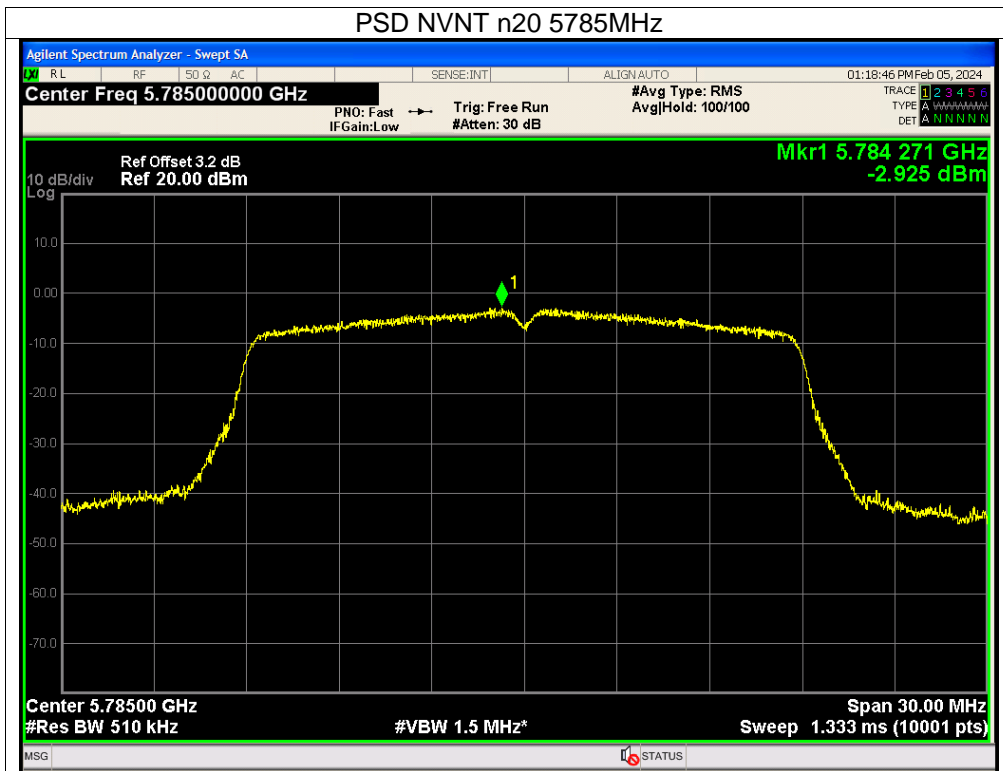

9. 26dB & 6dB & 99% Emission Bandwidth

9.1 Block Diagram Of Test Setup

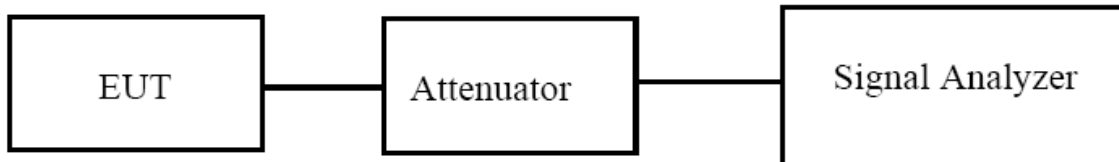

9.2 Limit

The maximum power spectral density is measured as a conducted emission by direct connection of a calibrated test instrument to the equipment under test. If the device cannot be connected directly, alternative techniques acceptable to the Commission may be used. Measurements in the 5.725-5.85 GHz band are made over a reference bandwidth of 500 kHz or the 26 dB emission bandwidth of the device, whichever is less. Measurements in the 5.15-5.25 GHz, 5.25-5.35 GHz, and the 5.47-5.725 GHz bands are made over a bandwidth of 1 MHz or the 26 dB emission bandwidth of the device, whichever is less. A narrower resolution bandwidth can be used, provided that the measured power is integrated over the full reference bandwidth.
(6dB bandwidth)>500kHz

9.3 Test Procedure

- a) Set RBW = approximately 1% of the emission bandwidth.
- b) Set the VBW > RBW.
- c) Detector = Peak.
- d) Trace mode = max hold.
- e) Measure the maximum width of the emission that is 26 dB down from the maximum of the emission. Compare this with the RBW setting of the analyzer. Readjust RBW and repeat measurement as needed until the RBW/EBW ratio is approximately 1%.

The following procedure shall be used for measuring (99 %) power bandwidth:

1. Set center frequency to the nominal EUT channel center frequency.
2. Set span = 1.5 times to 5.0 times the OBW.
3. Set RBW = 1 % to 5 % of the OBW
4. Set $VBW \geq 3 \cdot RBW$
5. Video averaging is not permitted. Where practical, a sample detection and single sweep mode shall be used. Otherwise, peak detection and max hold mode (until the trace stabilizes) shall be used.
6. Use the 99 % power bandwidth function of the instrument (if available).
7. If the instrument does not have a 99 % power bandwidth function, the trace data points are recovered and directly summed in power units. The recovered amplitude data points, beginning at the lowest frequency, are placed in a running sum until 0.5 % of the total is reached; that frequency is recorded as the lower frequency. The process is repeated until 99.5 % of the total is reached; that frequency is recorded as the upper frequency. The 99% occupied bandwidth is the difference between these two frequencies.

6dB

1. Set RBW = 100 kHz.
2. Set the video bandwidth (VBW) $\geq 3 \times RBW$.
3. Detector = Peak.
4. Trace mode = max hold.
5. Sweep = auto couple.
6. Allow the trace to stabilize.

7. Measure the maximum width of the emission that is constrained by the frequencies associated with the two outermost amplitude points (upper and lower frequencies) that are attenuated by 6 dB relative to the maximum level measured in the fundamental emission.

9.4 EUT Operating Conditions

The EUT was configured for testing in a typical fashion (as a customer would normally use it). The EUT has been programmed to continuously transmit during test. This operating condition was tested and used to collect the included data.

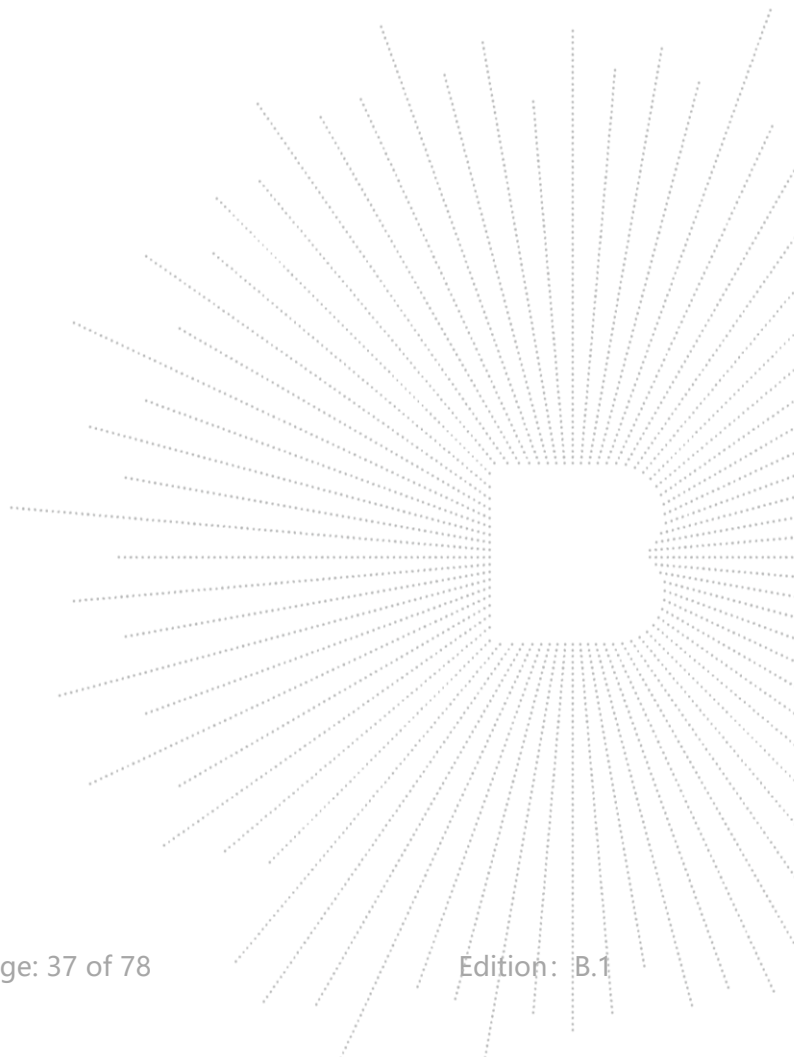

9.5 Test Result

Temperature:	26 °C	Relative Humidity:	54%
Pressure:	101KPa	Test Voltage:	AC 120V/60Hz
Test Mode:	(5180-5240MHz)		

Condition	Mode	Frequency (MHz)	99% bandwidth (MHz)	-26dB bandwidth (MHz)	Result
NVNT	a	5180	16.391	20.066	Pass
NVNT	a	5200	16.357	19.884	Pass
NVNT	a	5240	16.363	20.17	Pass
NVNT	n20	5180	17.489	20.229	Pass
NVNT	n20	5200	17.519	20.049	Pass
NVNT	n20	5240	17.513	20.147	Pass

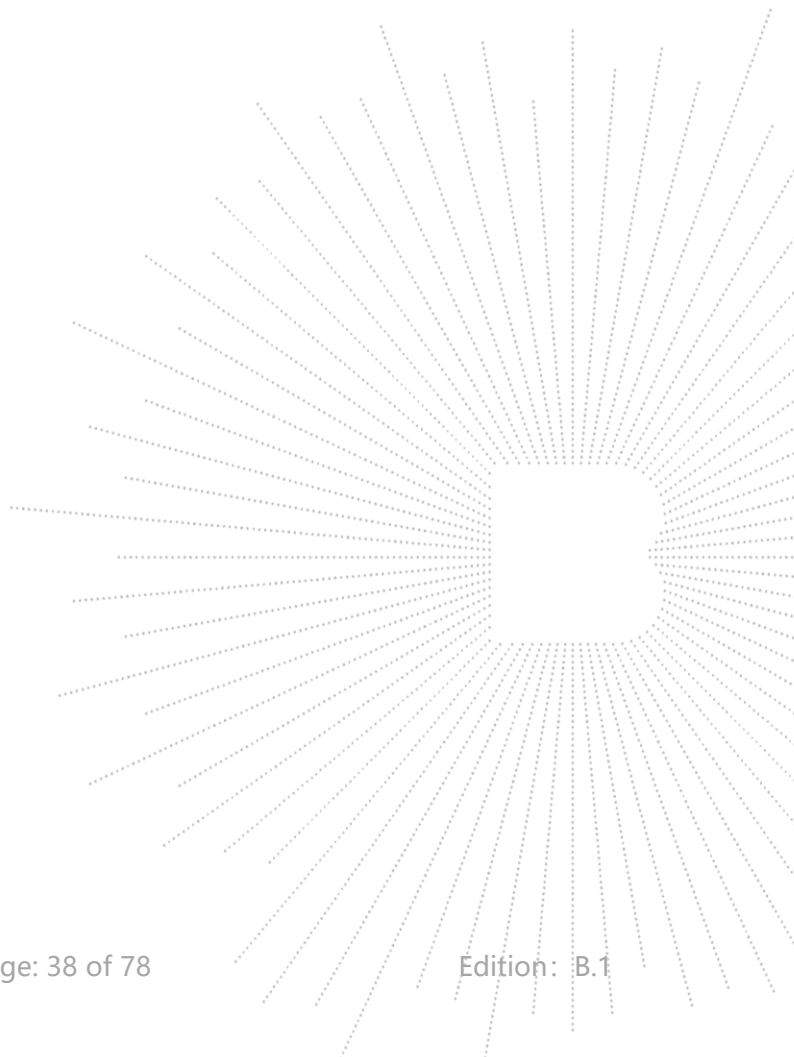

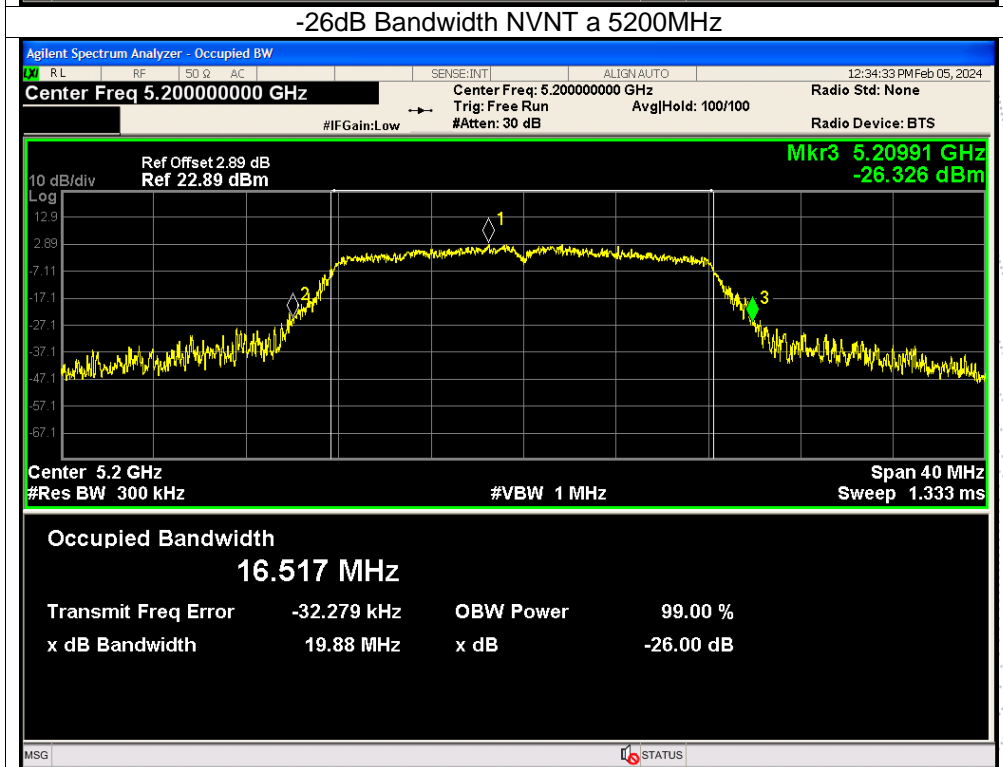
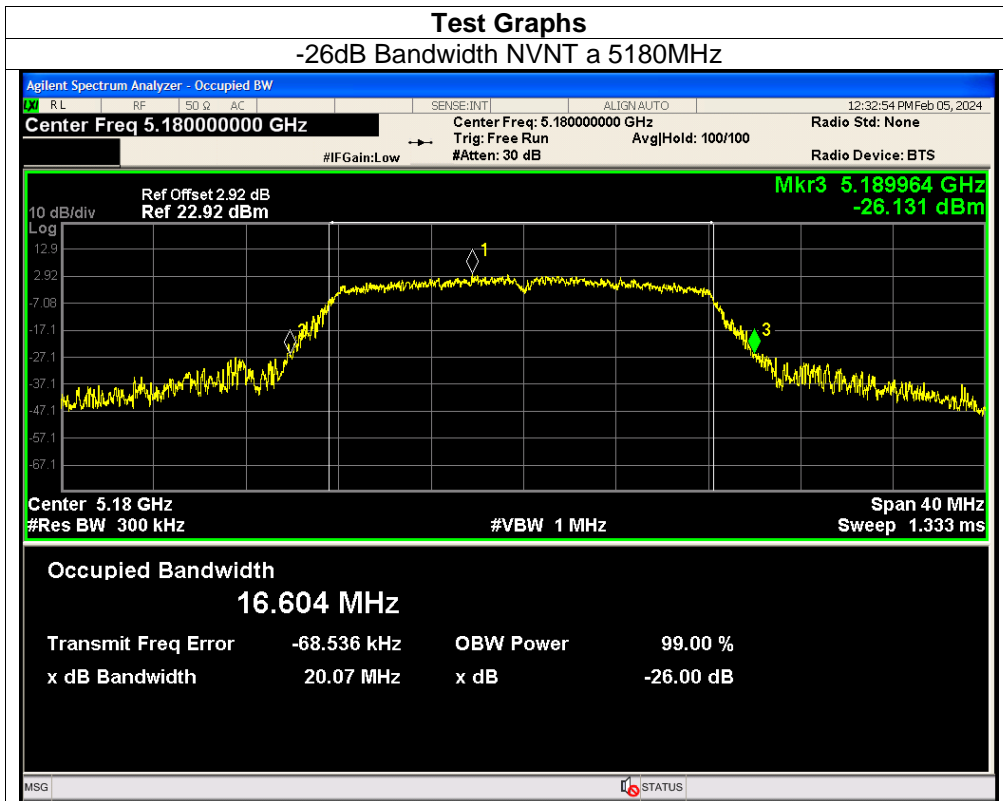

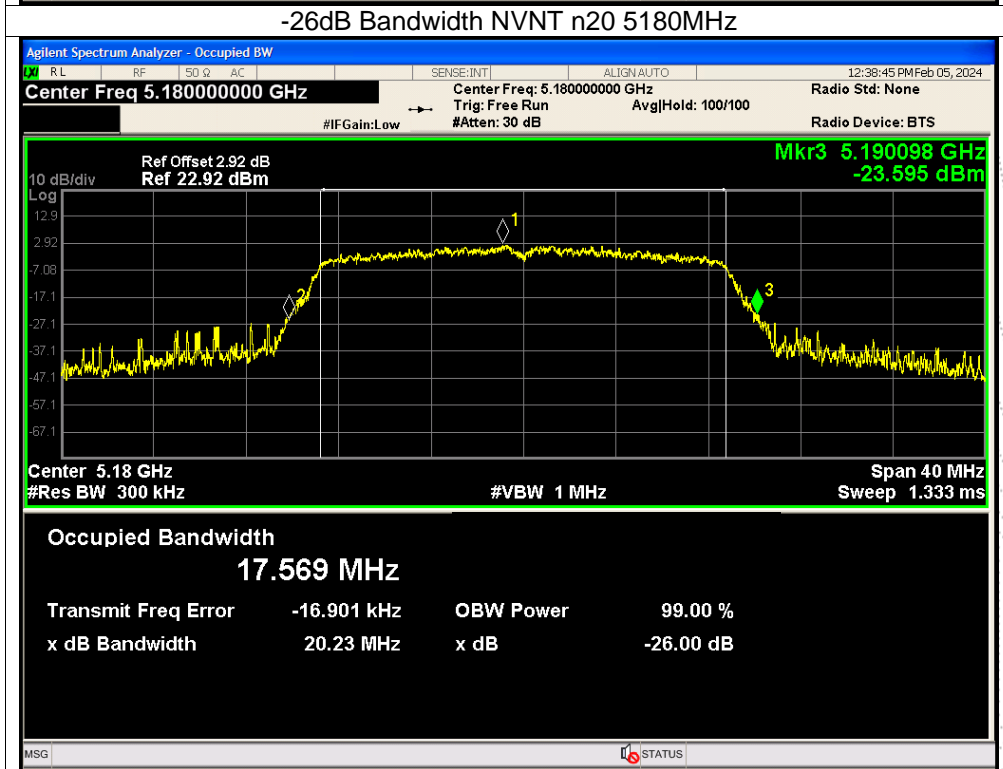
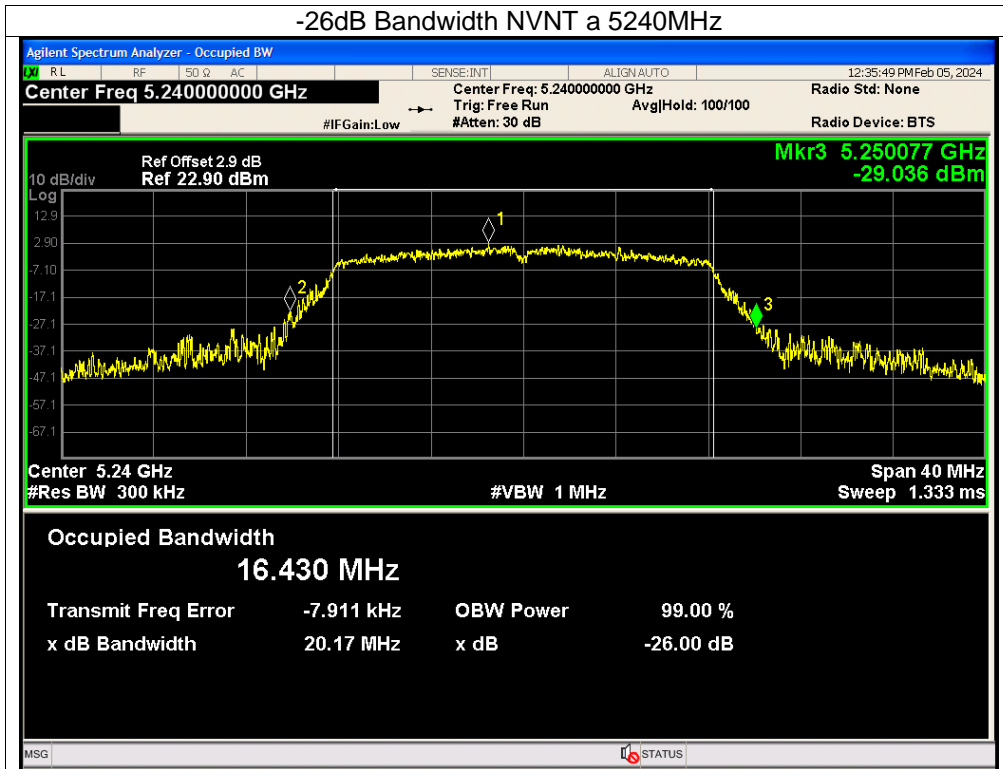

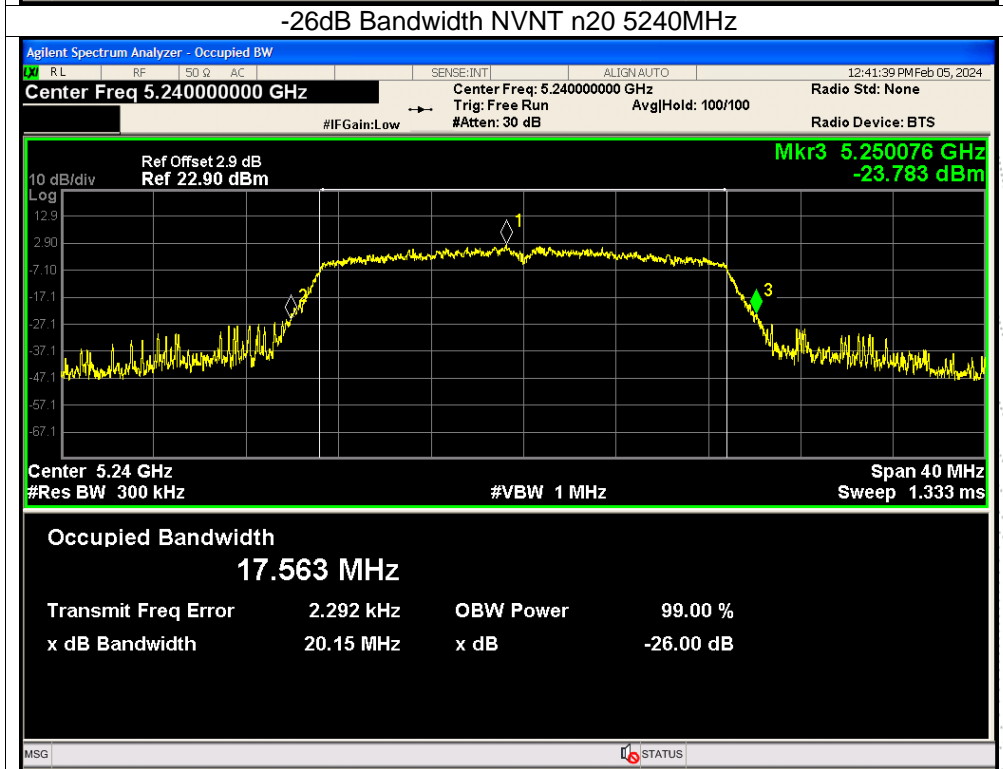
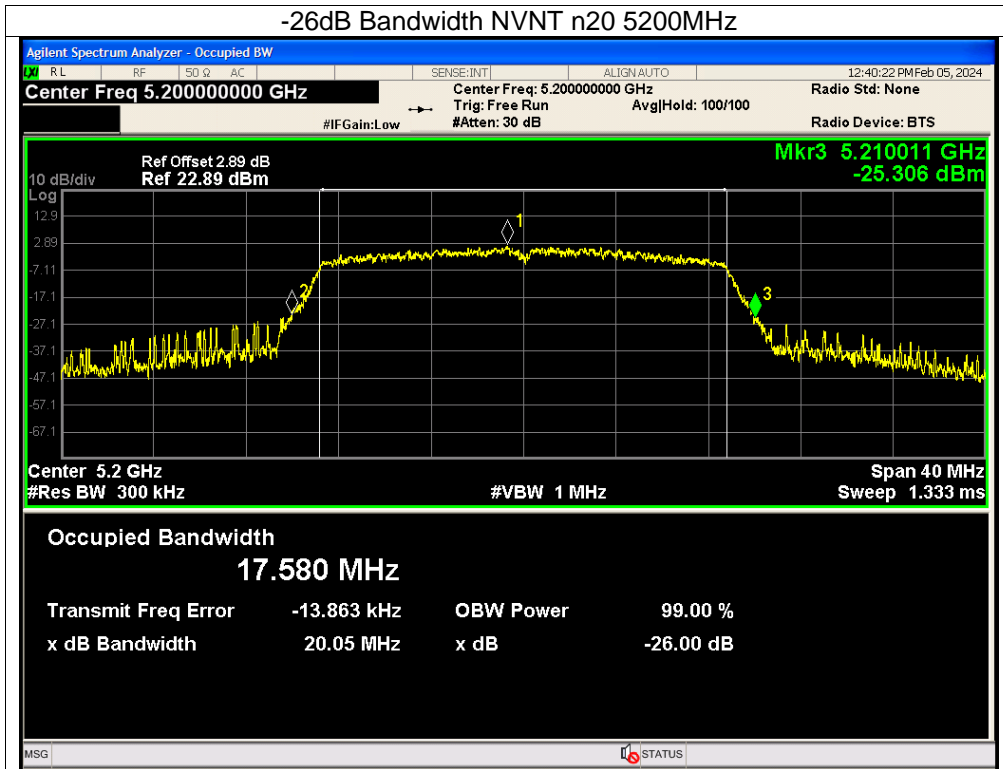

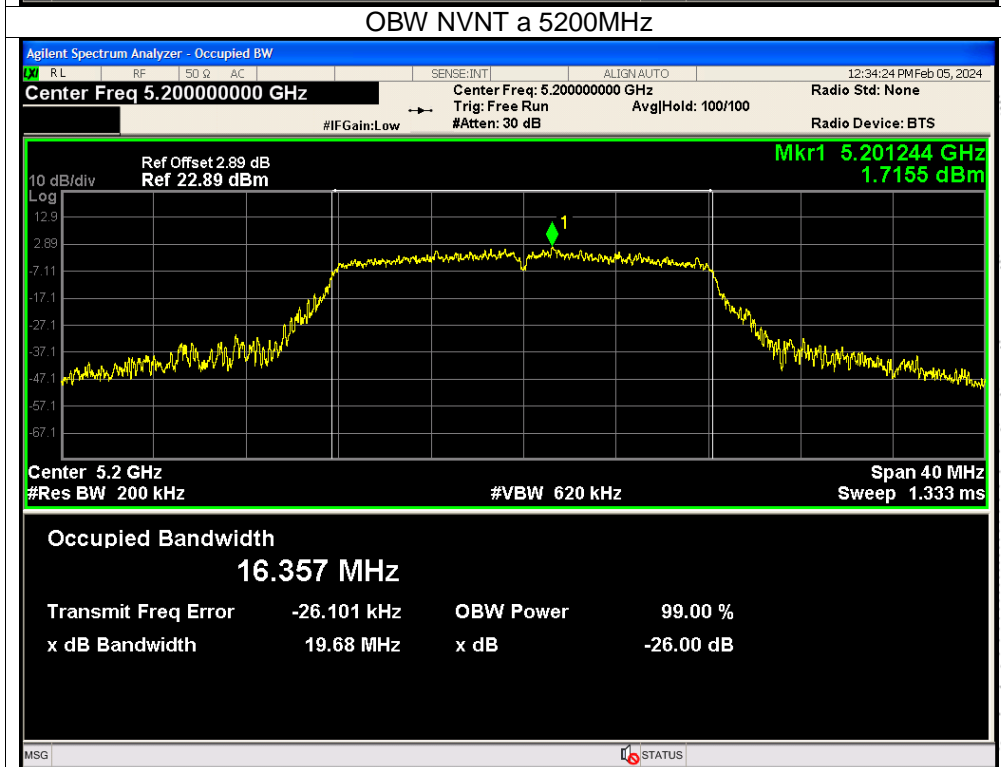
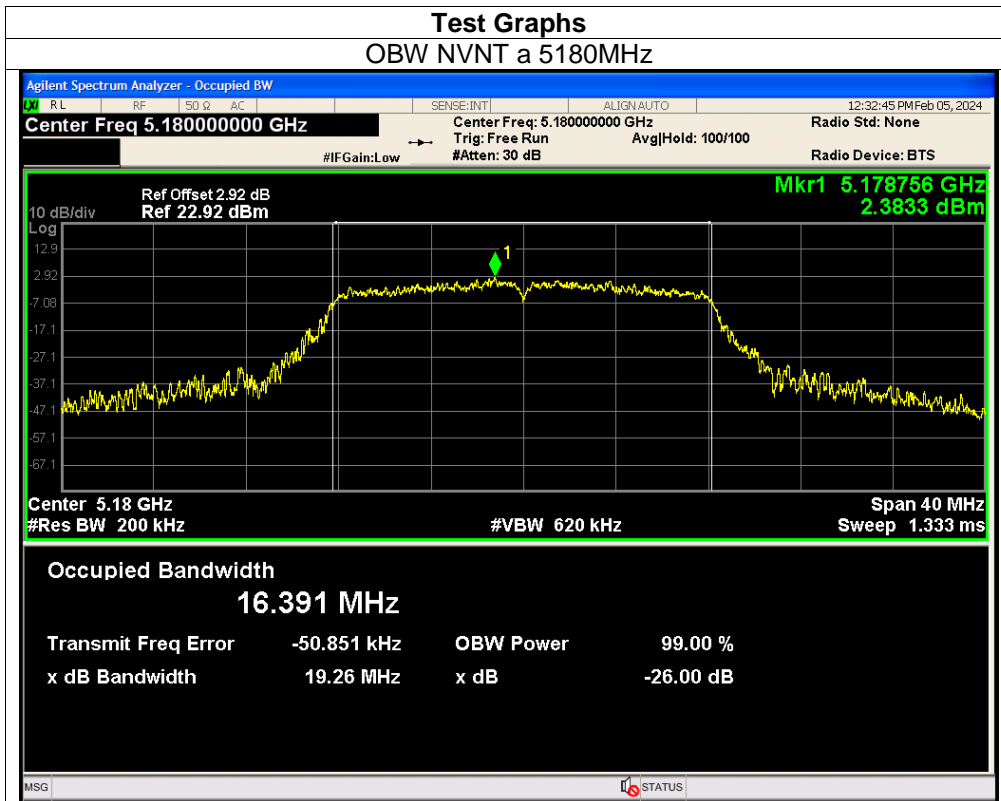

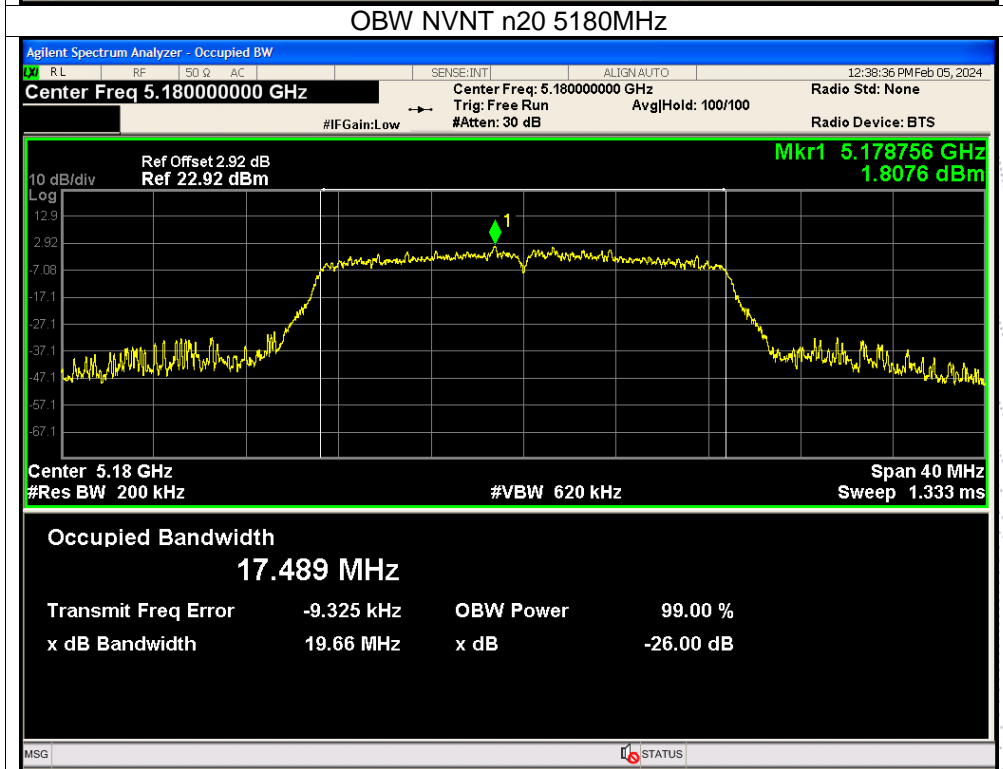
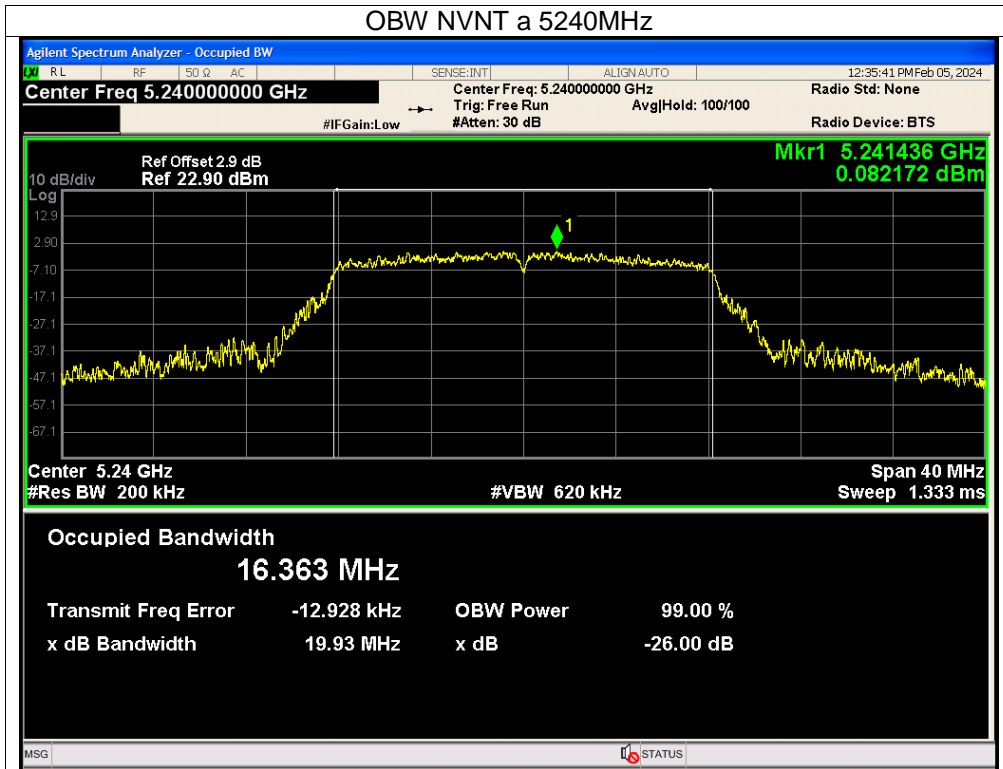

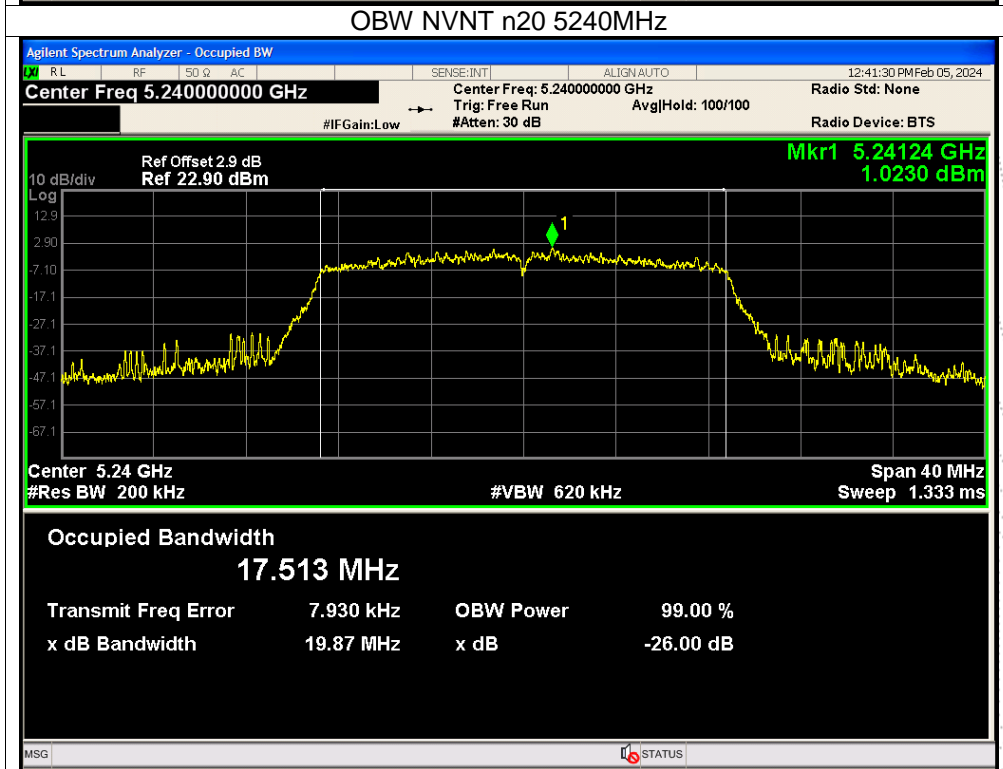
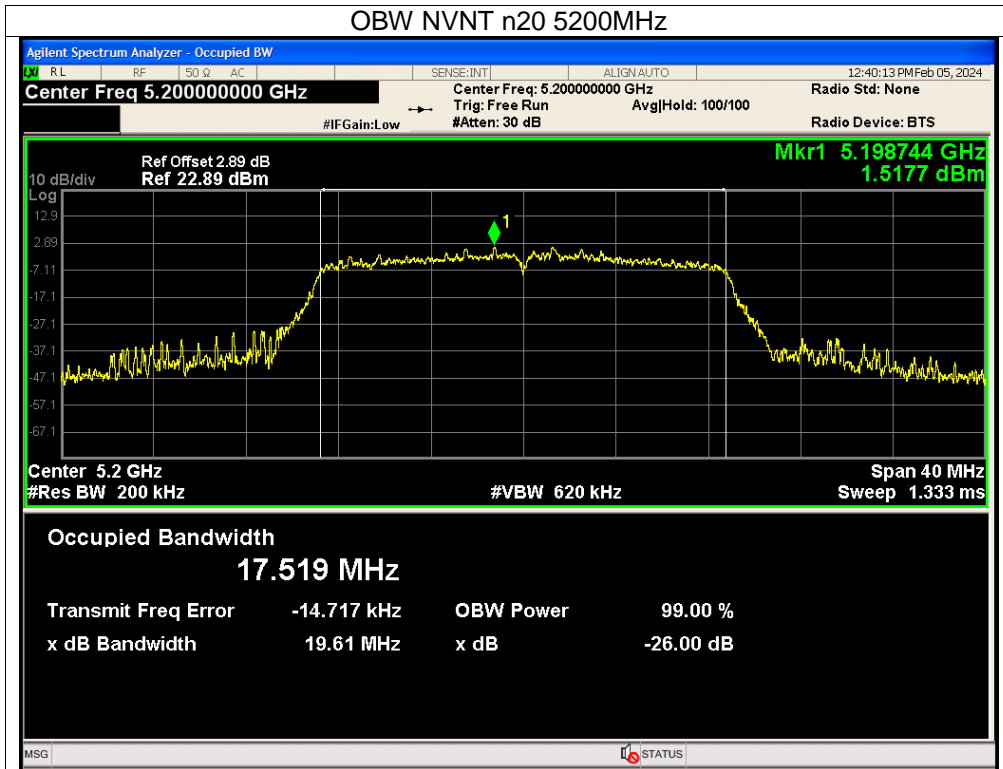

Temperature:	26 °C	Relative Humidity:	54%
Pressure:	101KPa	Test Voltage:	AC 120V/60Hz
Test Mode:	(5745-5825MHz)		

Condition	Mode	Frequency (MHz)	99% OBW (MHz)	-6dB bandwidth (MHz)	Limit -6dB bandwidth MHz	Result
NVNT	a	5745	16.393	13.803	≥500	Pass
NVNT	a	5785	16.392	12.647	≥500	Pass
NVNT	a	5825	16.343	12.788	≥500	Pass
NVNT	n20	5745	17.521	14.964	≥500	Pass
NVNT	n20	5785	17.52	13.833	≥500	Pass
NVNT	n20	5825	17.495	12.8	≥500	Pass

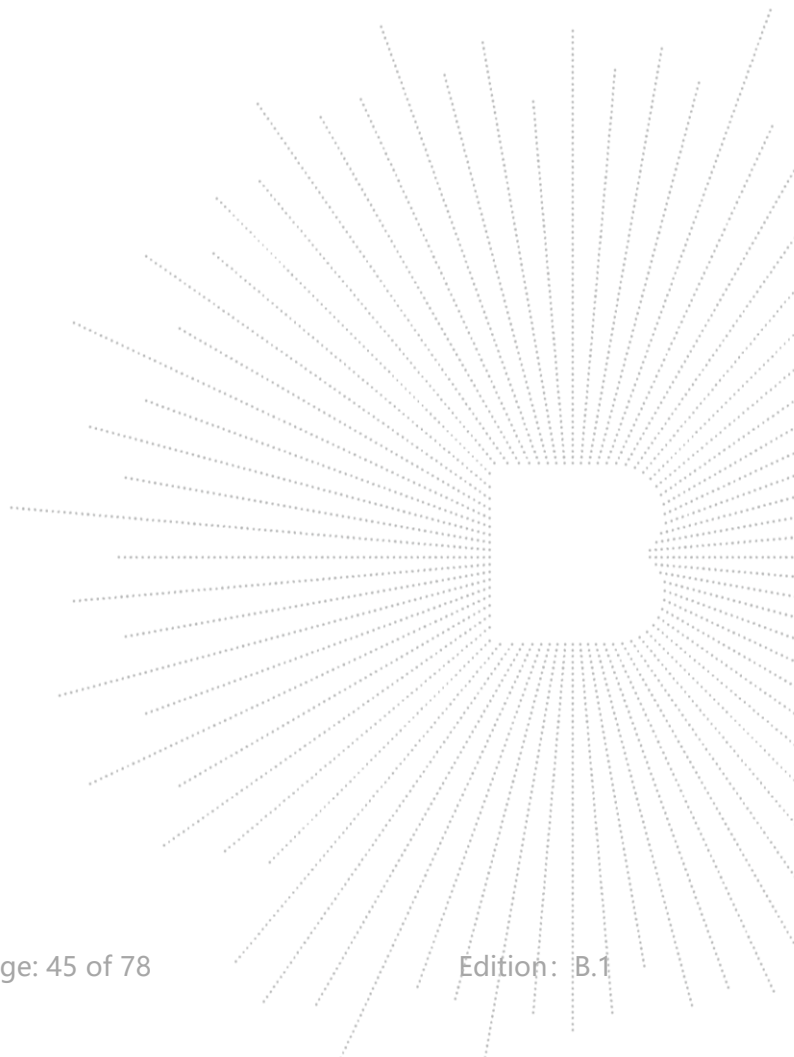

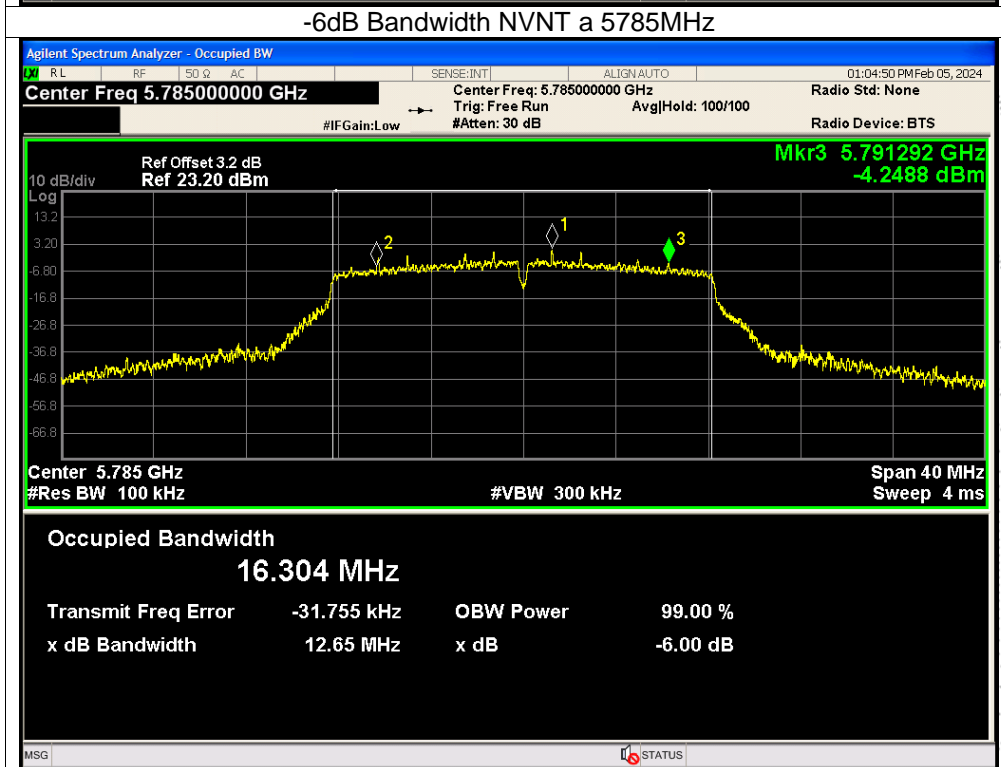
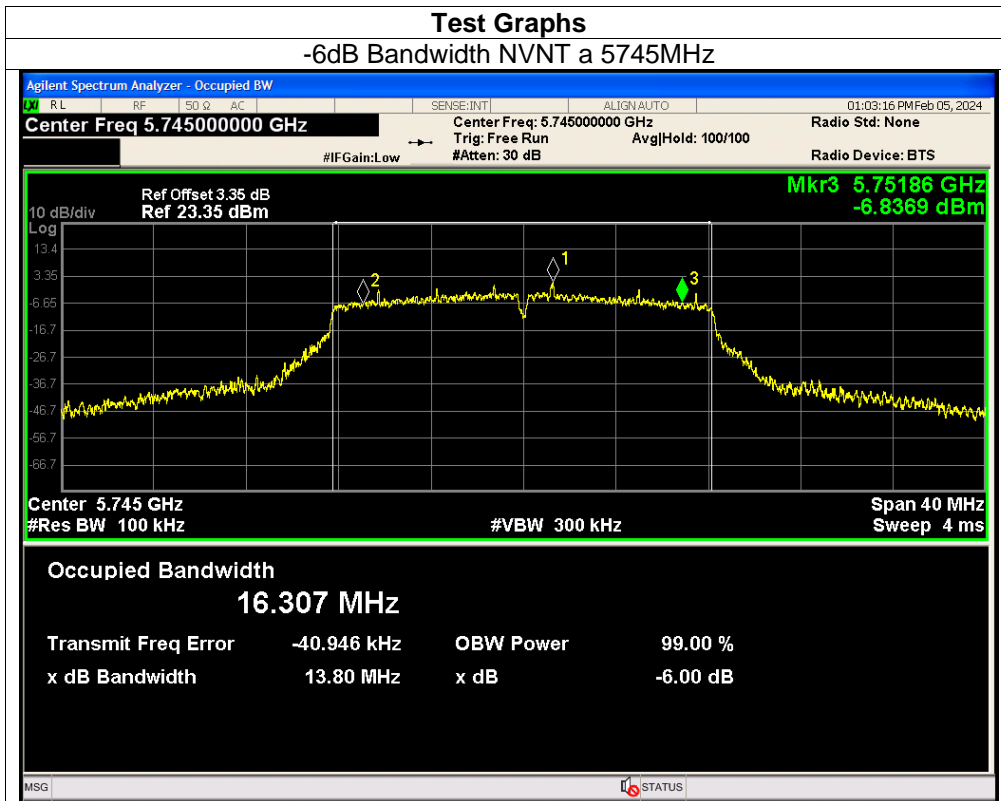

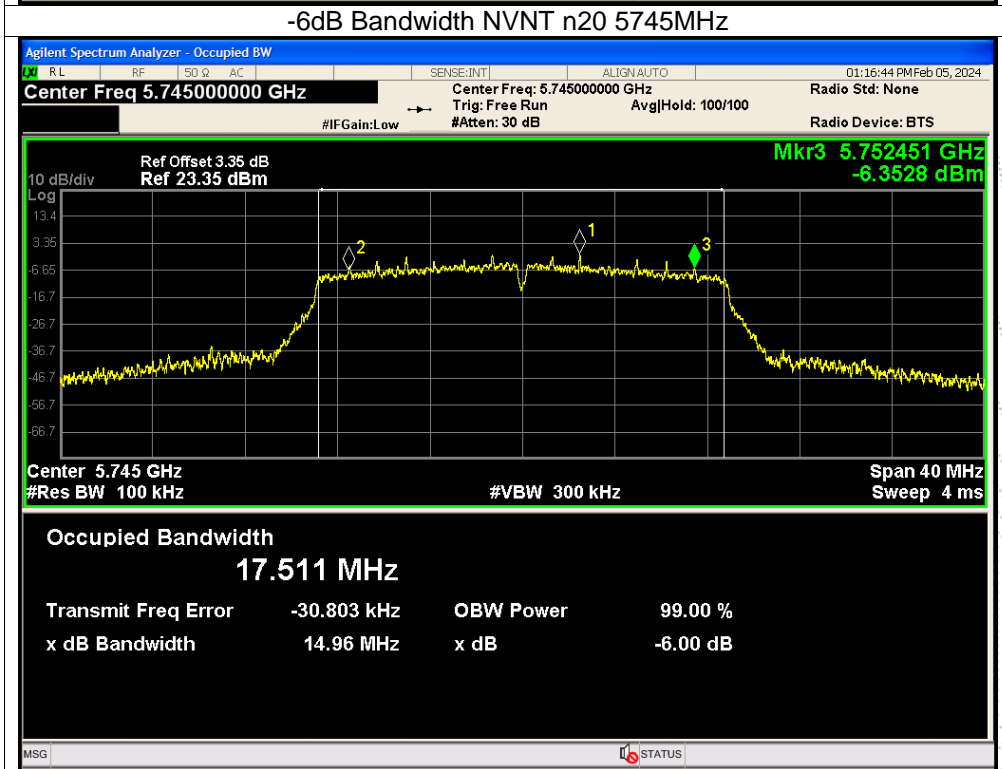
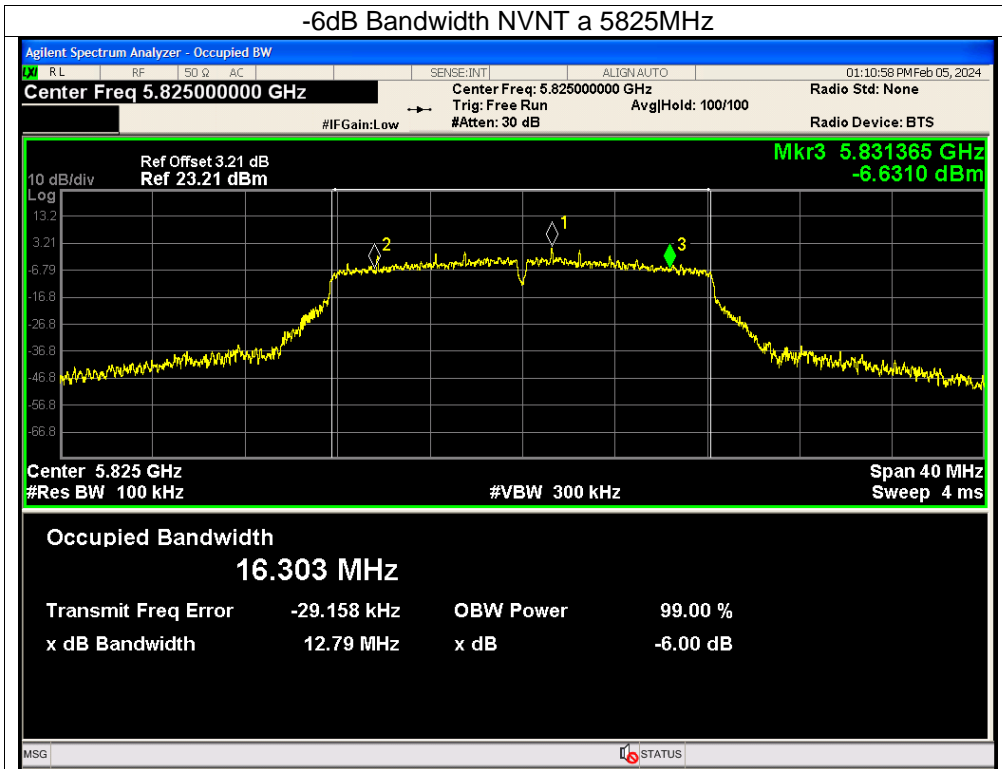

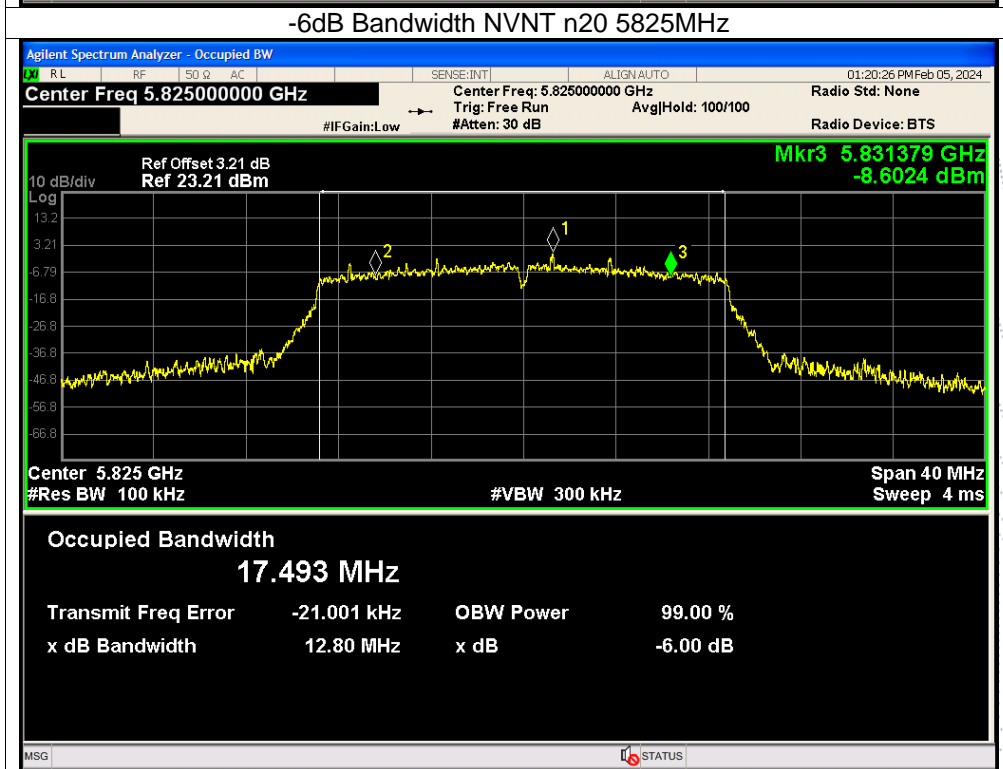
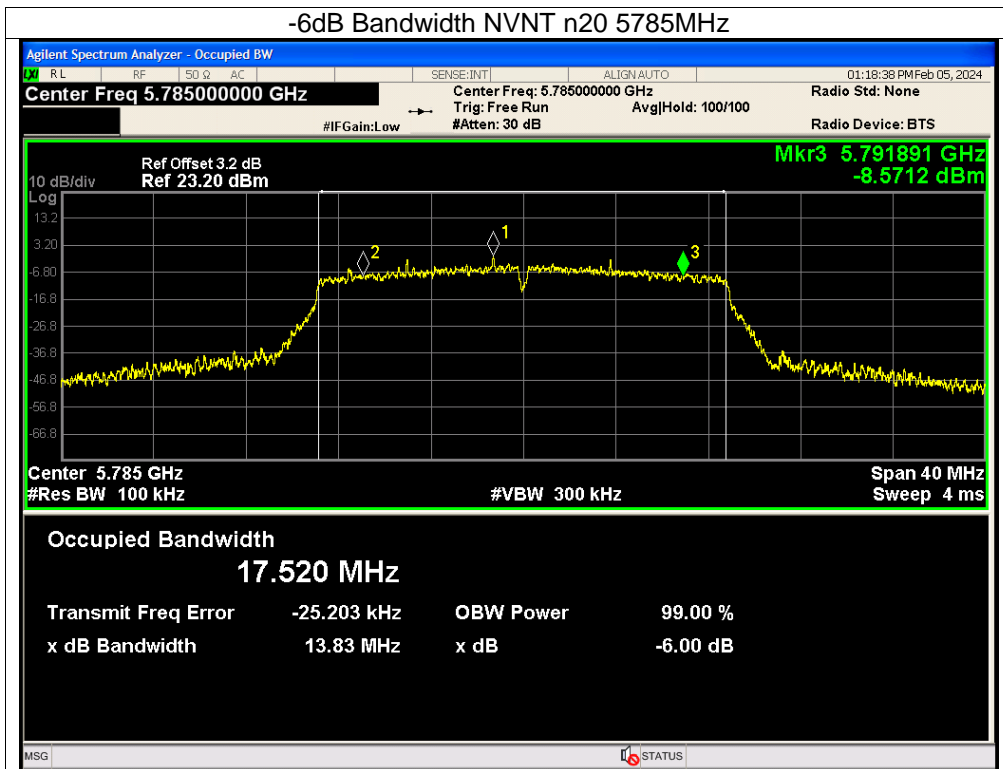

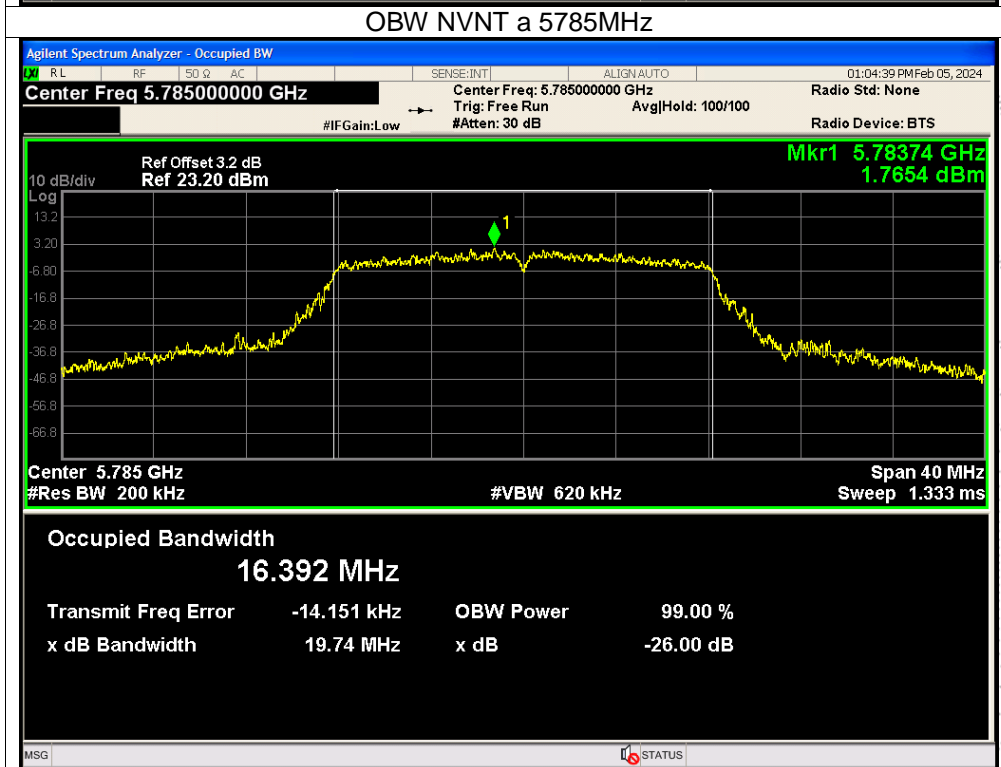
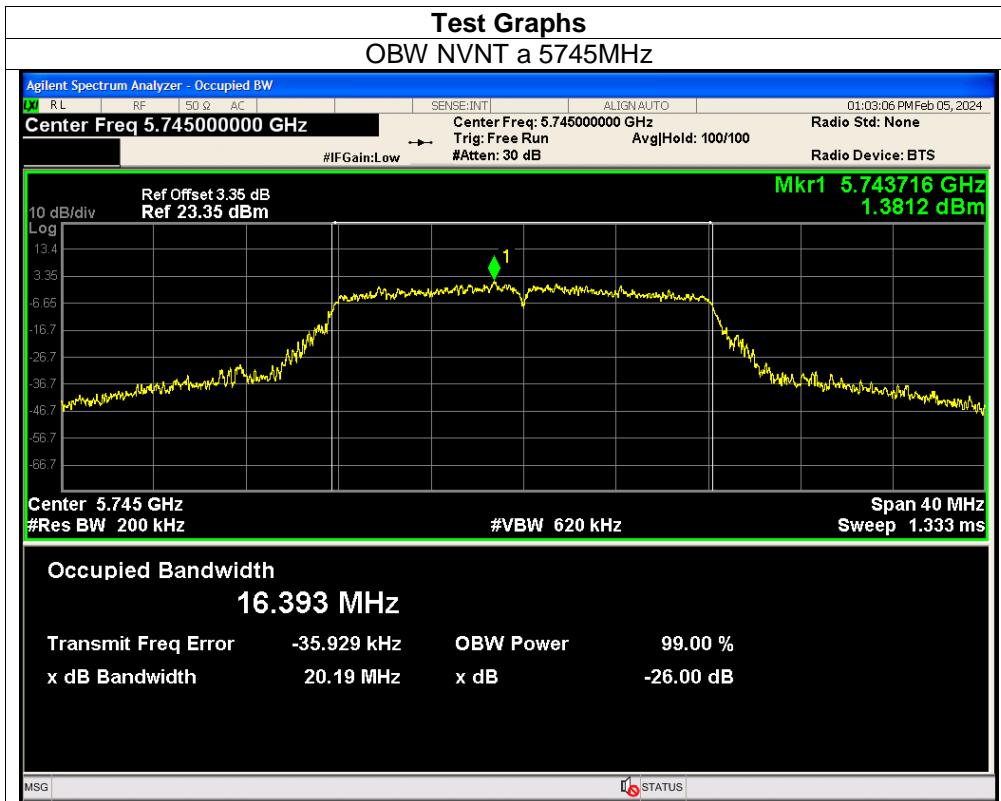

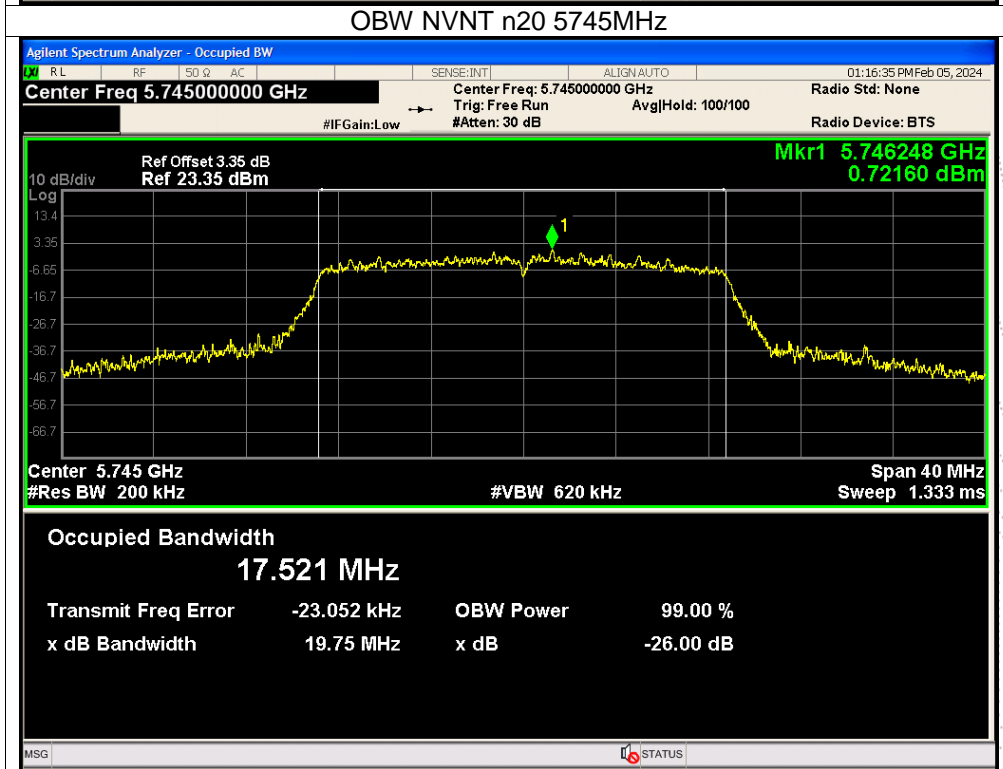
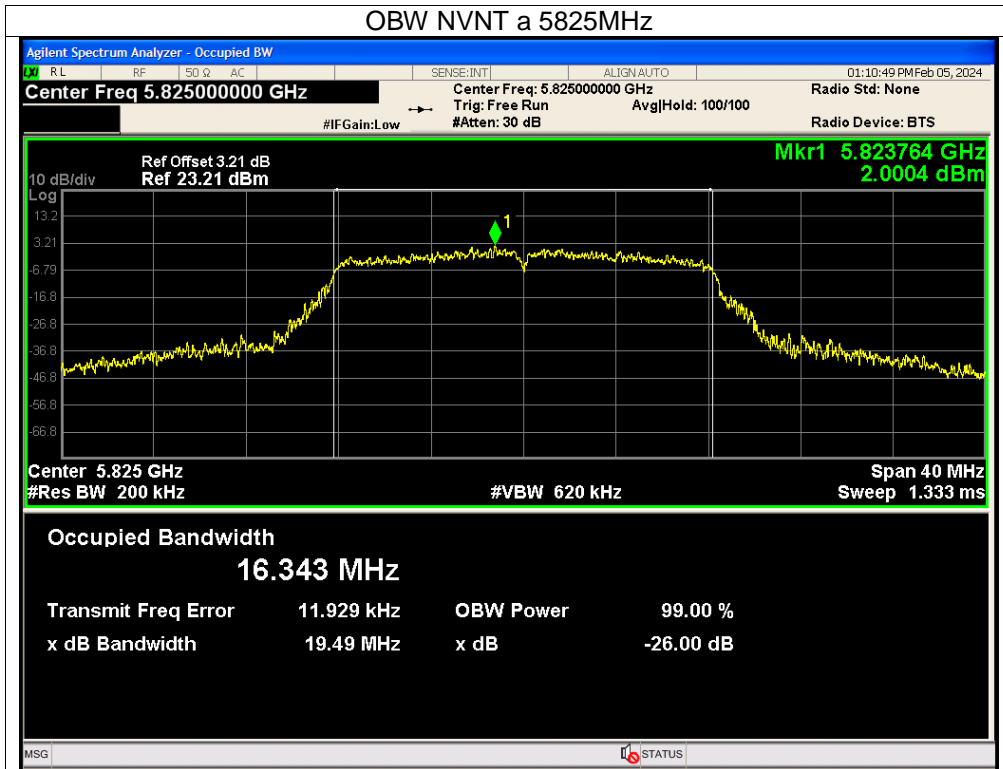

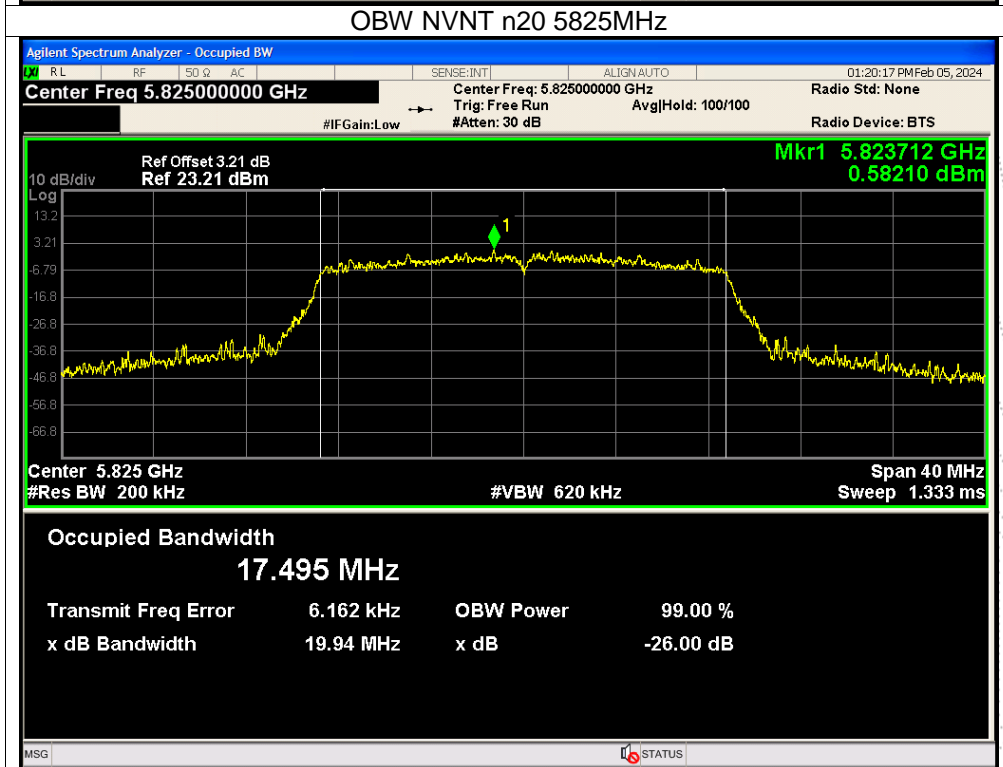
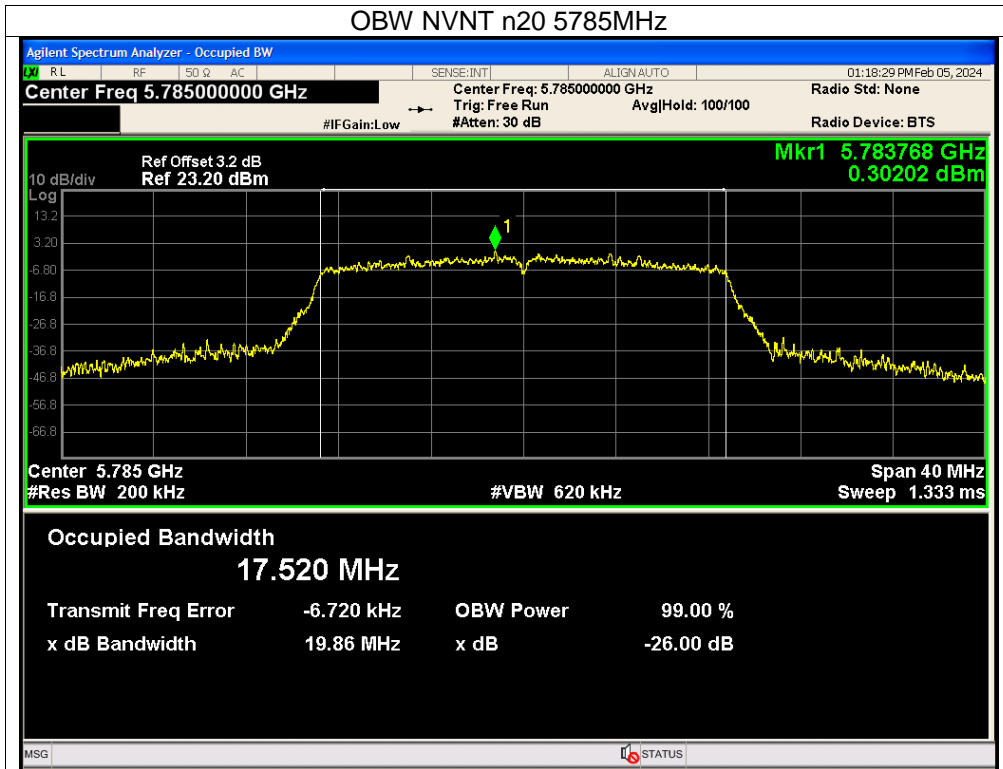

10. Maximum Conducted Output Power

10.1 Block Diagram Of Test Setup

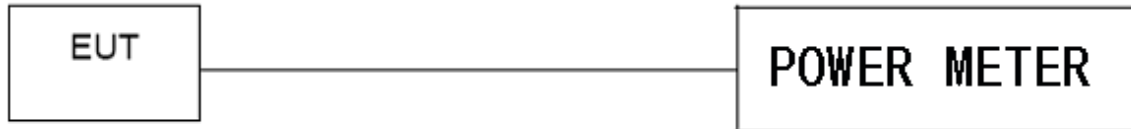

10.2 Limit

According to FCC §15.407

The maximum conducted output power should not exceed:

Frequency Band(MHz)	Limit
5150~5250	250mW
5725~5850	1W

10.3 Test Procedure

Maximum conducted output power may be measured using a spectrum analyzer/EMI receiver or an RF power meter.

1. Device Configuration

If possible, configure or modify the operation of the EUT so that it transmits continuously at its maximum power control level (see section II.B.).

a) The intent is to test at 100 percent duty cycle; however a small reduction in duty cycle (to no lower than 98 percent) is permitted if required by the EUT for amplitude control purposes. Manufacturers are expected to provide software to the test lab to permit such continuous operation.

b) If continuous transmission (or at least 98 percent duty cycle) cannot be achieved due to hardware limitations (e.g., overheating), the EUT shall be operated at its maximum power control level with the transmit duration as long as possible and the duty cycle as high as possible.

2. Measurement using a Spectrum Analyzer or EMI Receiver (SA)

Measurement of maximum conducted output power using a spectrum analyzer requires integrating the spectrum across a frequency span that encompasses, at a minimum, either the EBW or the 99-percent occupied bandwidth of the signal. However, the EBW must be used to determine bandwidth dependent limits on maximum conducted output power in accordance with § 15.407(a).

a) The test method shall be selected as follows: (i) Method SA-1 or SA-1 Alternative (averaging with the EUT transmitting at full power throughout each sweep) shall be applied if either of the following conditions can be satisfied:

- The EUT transmits continuously (or with a duty cycle ≥ 98 percent).
- Sweep triggering or gating can be implemented in a way that the device transmits at the maximum power control level throughout the duration of each of the instrument sweeps to be averaged. This condition can generally be achieved by triggering the instrument's sweep if the duration of the sweep (with the analyzer configured as in Method SA-1, below) is equal to or shorter than the duration T of each transmission from the EUT and if those transmissions exhibit full power throughout their durations.

(ii) Method SA-2 or SA-2 Alternative (averaging across on and off times of the EUT transmissions, followed by duty cycle correction) shall be applied if the conditions of (i) cannot be achieved and the transmissions exhibit a constant duty cycle during the measurement duration. Duty cycle will be considered to be constant if variations are less than ± 2 percent.

- (iii) Method SA-3 (RMS detection with max hold) or SA-3 Alternative (reduced VBW with max hold) shall be applied if the conditions of (i) and (ii) cannot be achieved.
- b) Method SA-1 (trace averaging with the EUT transmitting at full power throughout each sweep):
 - (i) Set span to encompass the entire emission bandwidth (EBW) (or, alternatively, the entire 99% occupied bandwidth) of the signal.
 - (ii) Set RBW = 1 MHz.
 - (iii) Set VBW \geq 3 MHz.
 - (iv) Number of points in sweep \geq 2 Span / RBW. (This ensures that bin-to-bin spacing is \leq RBW/2, so that narrowband signals are not lost between frequency bins.)
 - (v) Sweep time = auto.
 - (vi) Detector = RMS (i.e., power averaging), if available. Otherwise, use sample detector mode.
 - (vii) If transmit duty cycle < 98 percent, use a video trigger with the trigger level set to enable triggering only on full power pulses. Transmitter must operate at maximum power control level for the entire duration of every sweep. If the EUT transmits continuously (i.e., with no off intervals) or at duty cycle \geq 98 percent, and if each transmission is entirely at the maximum power control level, then the trigger shall be set to "free run".
 - (viii) Trace average at least 100 traces in power averaging (i.e., RMS) mode.
 - (ix) Compute power by integrating the spectrum across the EBW (or, alternatively, the entire 99% occupied bandwidth) of the signal using the instrument's band power measurement function with band limits set equal to the EBW (or occupied bandwidth) band edges. If the instrument does not have a band power function, sum the spectrum

10.4 EUT Operating Conditions

The EUT was configured for testing in a typical fashion (as a customer would normally use it). The EUT has been programmed to continuously transmit during test. This operating condition was tested and used to collect the included data.

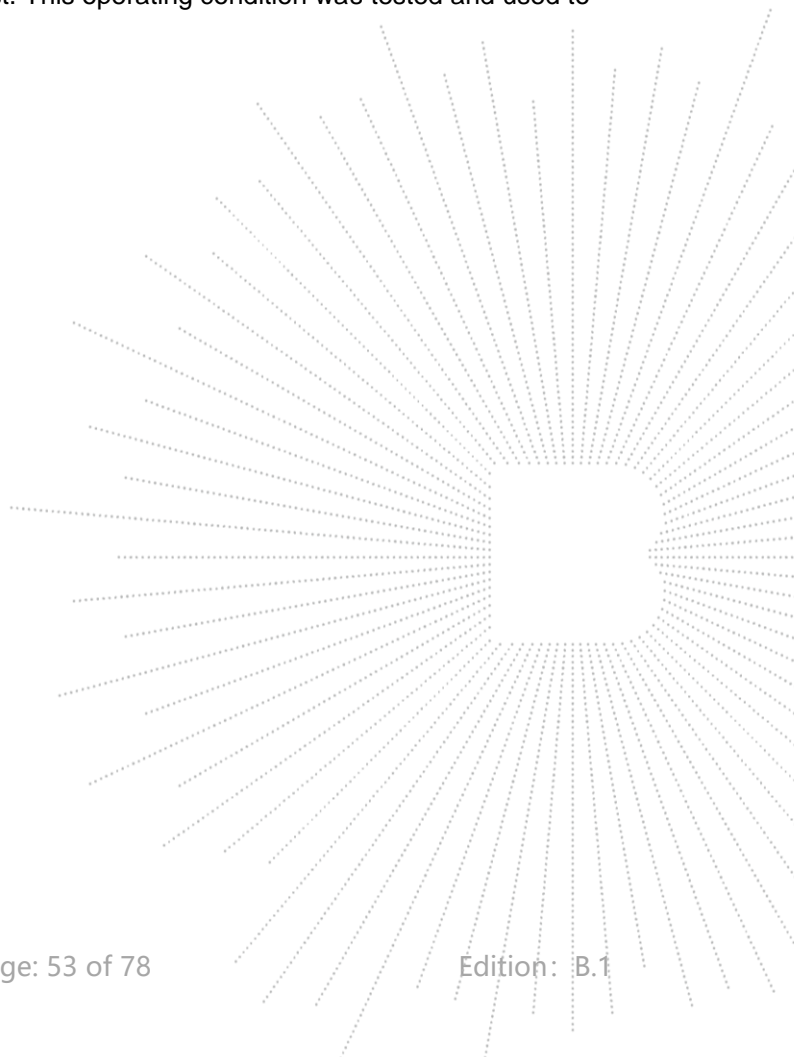

10.5 Test Result

Temperature:	26 °C	Relative Humidity:	54%
Pressure:	101KPa	Test Voltage:	AC 120V/60Hz
Test Mode:	5180-5240MHz		

Condition	Mode	Frequency (MHz)	Conducted Power (dBm)	Limit (dBm)	Verdict
NVNT	a	5180	11.58	24	Pass
NVNT	a	5200	10.88	24	Pass
NVNT	a	5240	10.13	24	Pass
NVNT	n20	5180	10.72	24	Pass
NVNT	n20	5200	10.41	24	Pass
NVNT	n20	5240	10.17	24	Pass

Temperature:	26 °C	Relative Humidity:	54%
Pressure:	101KPa	Test Voltage:	AC 120V/60Hz
Test Mode:	5745-5825MHz		

Condition	Mode	Frequency (MHz)	Conducted Power (dBm)	Limit (dBm)	Verdict
NVNT	a	5745	10.8	30	Pass
NVNT	a	5785	10.87	30	Pass
NVNT	a	5825	11.2	30	Pass
NVNT	n20	5745	9.53	30	Pass
NVNT	n20	5785	10.67	30	Pass
NVNT	n20	5825	10.03	30	Pass

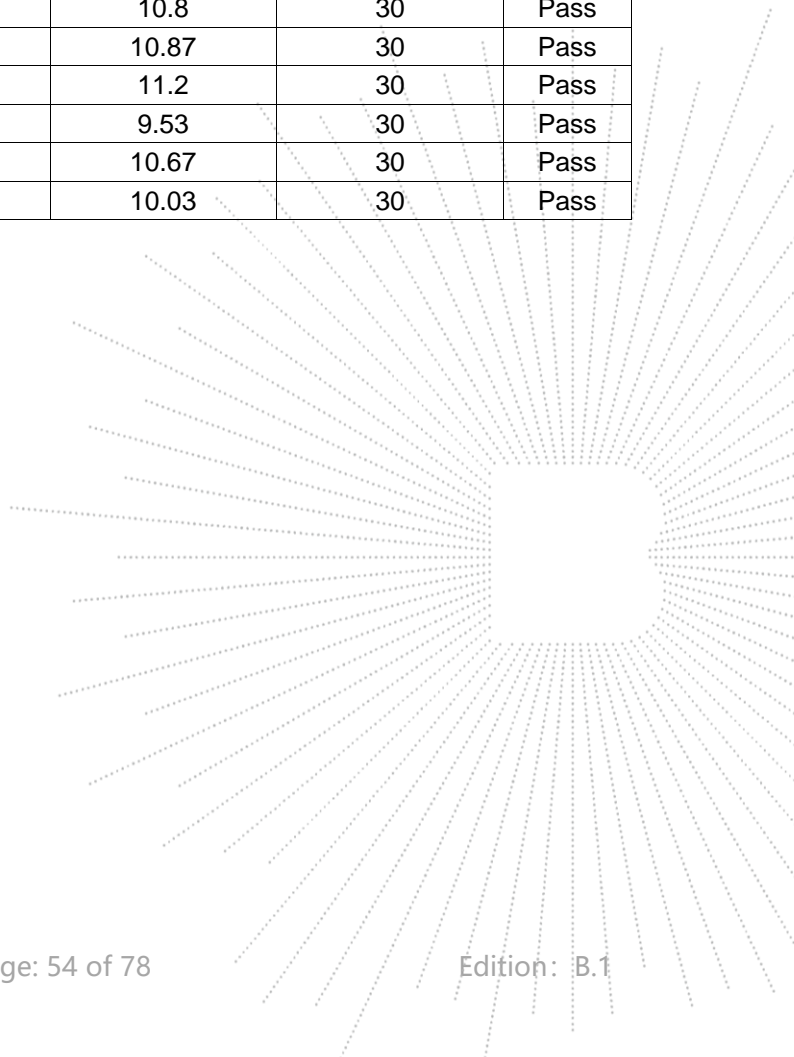

11. Out Of Band Emissions

11.1 Block Diagram Of Test Setup

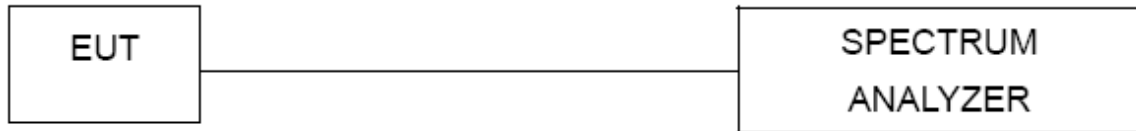

11.2 Limit

According to FCC §15.407(b)

Undesirable emission limits. Except as shown in paragraph (b)(7) of this section, the maximum emissions outside of the frequency bands of operation shall be attenuated in accordance with the following limits:

- (1) For transmitters operating in the 5.15-5.25 GHz band: All emissions outside of the 5.15-5.35 GHz band shall not exceed an e.i.r.p. of -27 dBm/MHz.
- (2) All emissions shall be limited to a level of -27 dBm/MHz at 75 MHz or more above or below the band edge increasing linearly to 10 dBm/MHz at 25 MHz above or below the band edge, and from 25 MHz above or below the band edge increasing linearly to a level of 15.6 dBm/MHz at 5 MHz above or below the band edge, and from 5 MHz above or below the band edge increasing linearly to a level of 27 dBm/MHz at the band edge.

11.3 Test Procedure

1. Check the calibration of the measuring instrument using either an internal calibrator or a known signal from an external generator.
2. Position the EUT without connection to measurement instrument. Turn on the EUT and connect its antenna terminal to measurement instrument via a low loss cable. Then set it to any one measured frequency within its operating range, and make sure the instrument is operated in its linear range.
3. Set RBW of spectrum analyzer to 1 MHz with a convenient frequency span.
4. Measure the highest amplitude appearing on spectral display and set it as a reference level. Plot the graph with marking the highest point and edge frequency.
5. Repeat above procedures until all measured frequencies were complete.

11.4 EUT Operating Conditions

The EUT was configured for testing in a typical fashion (as a customer would normally use it). The EUT has been programmed to continuously transmit during test. This operating condition was tested and used to collect the included data

11.5 Test Result

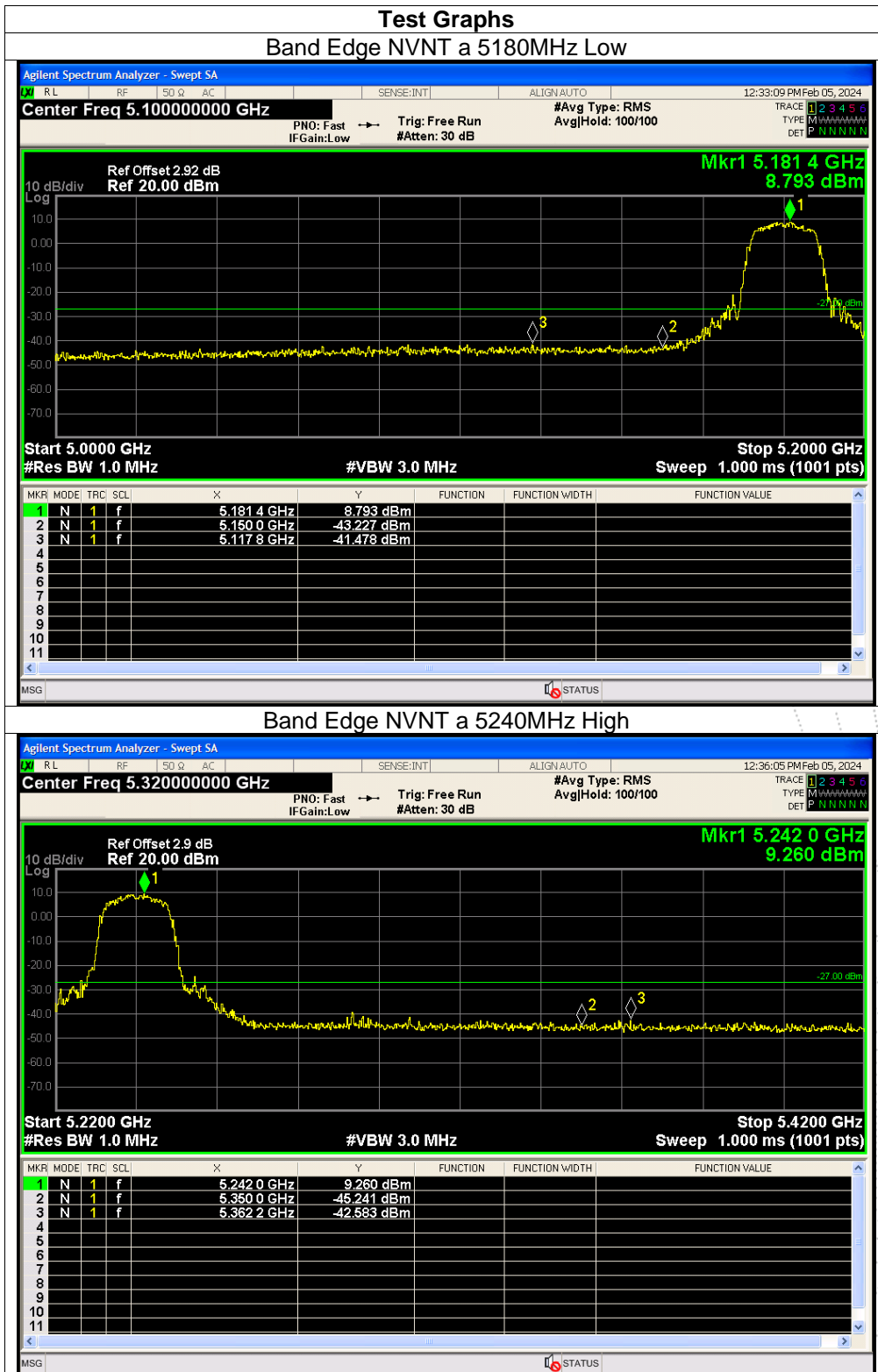

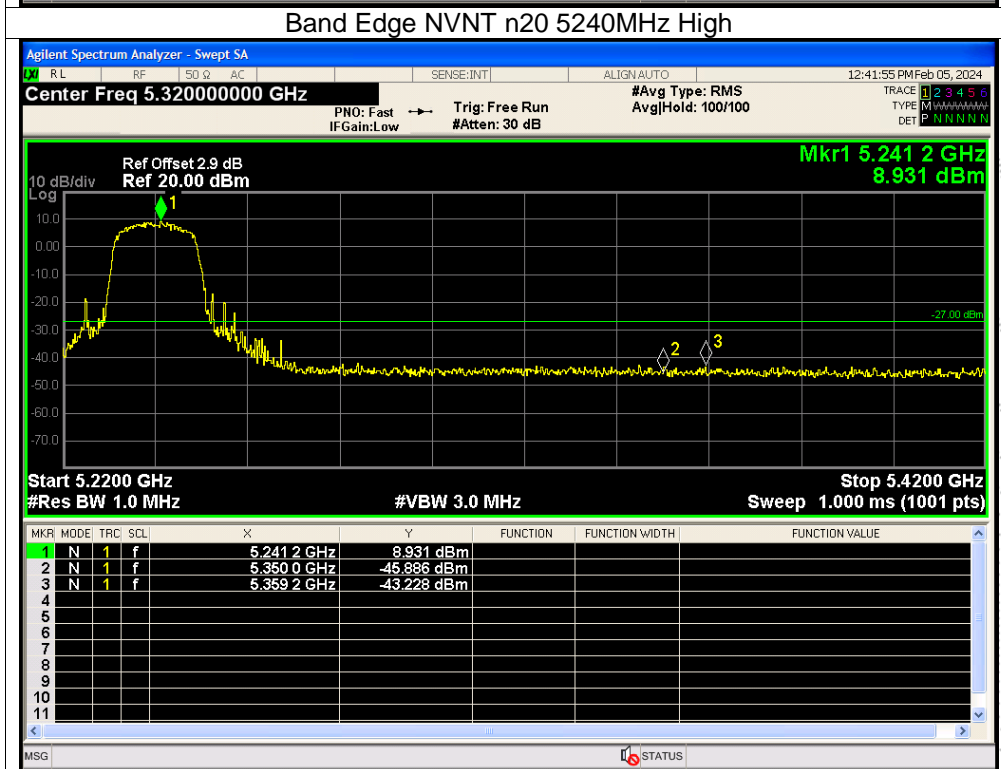
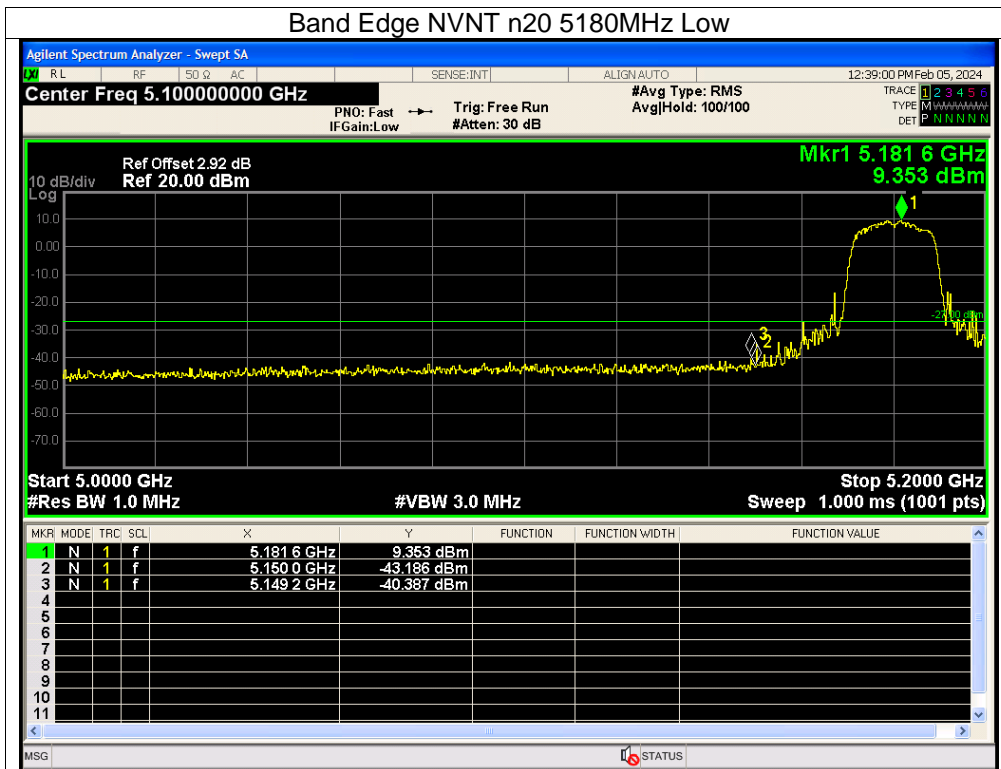

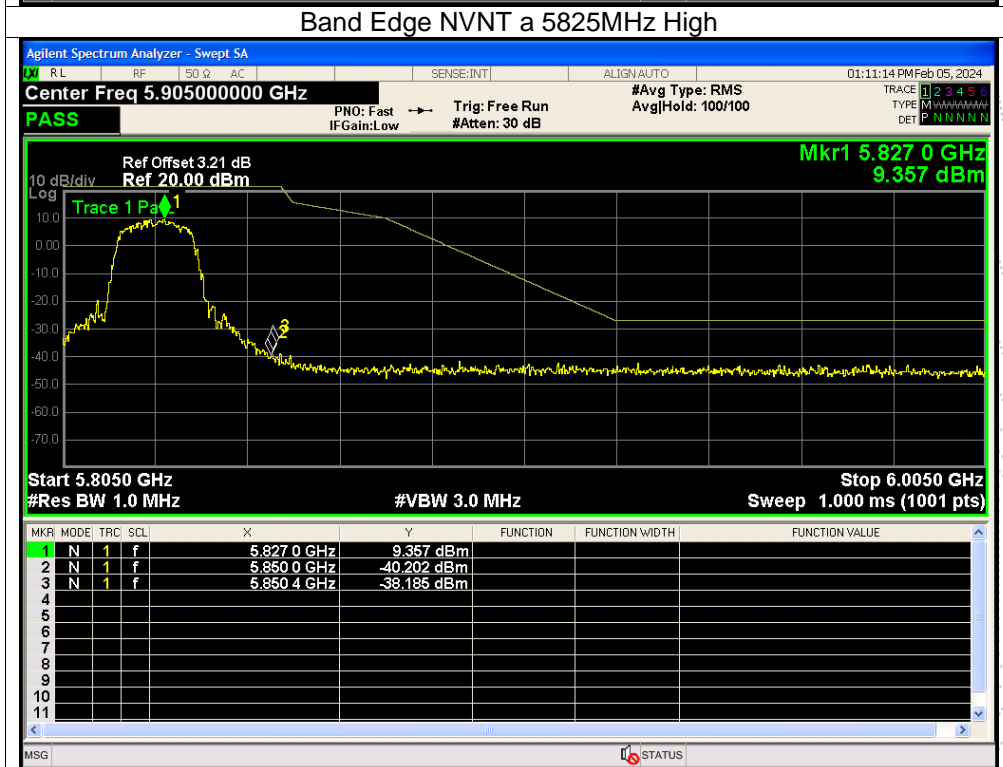
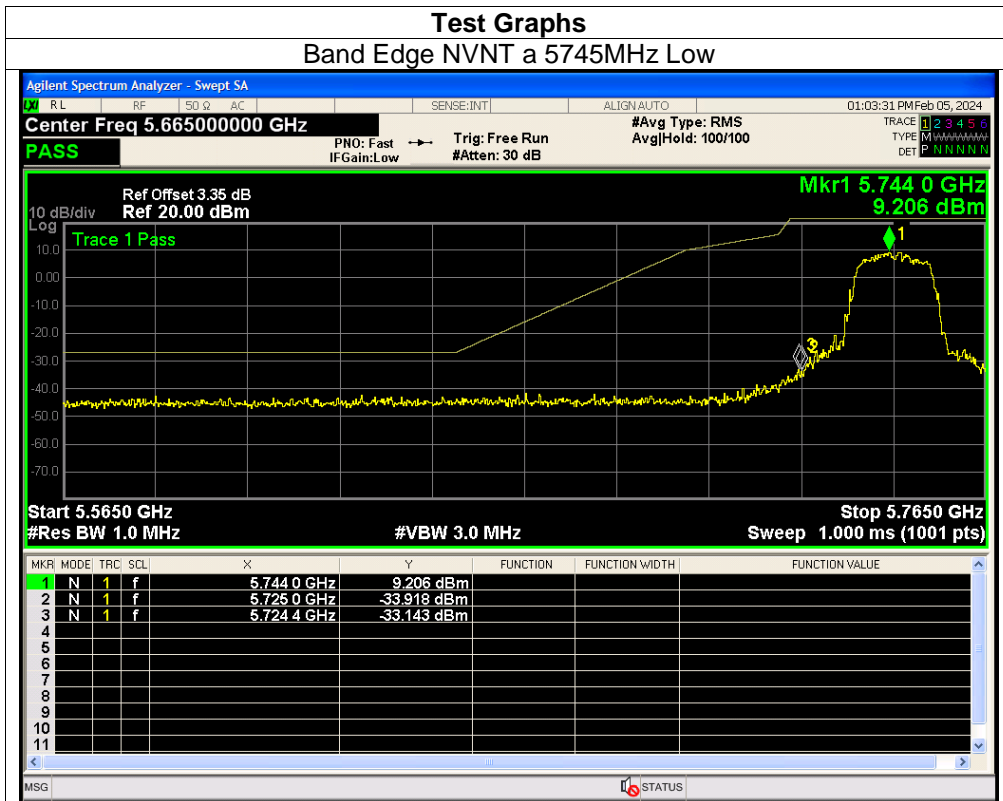

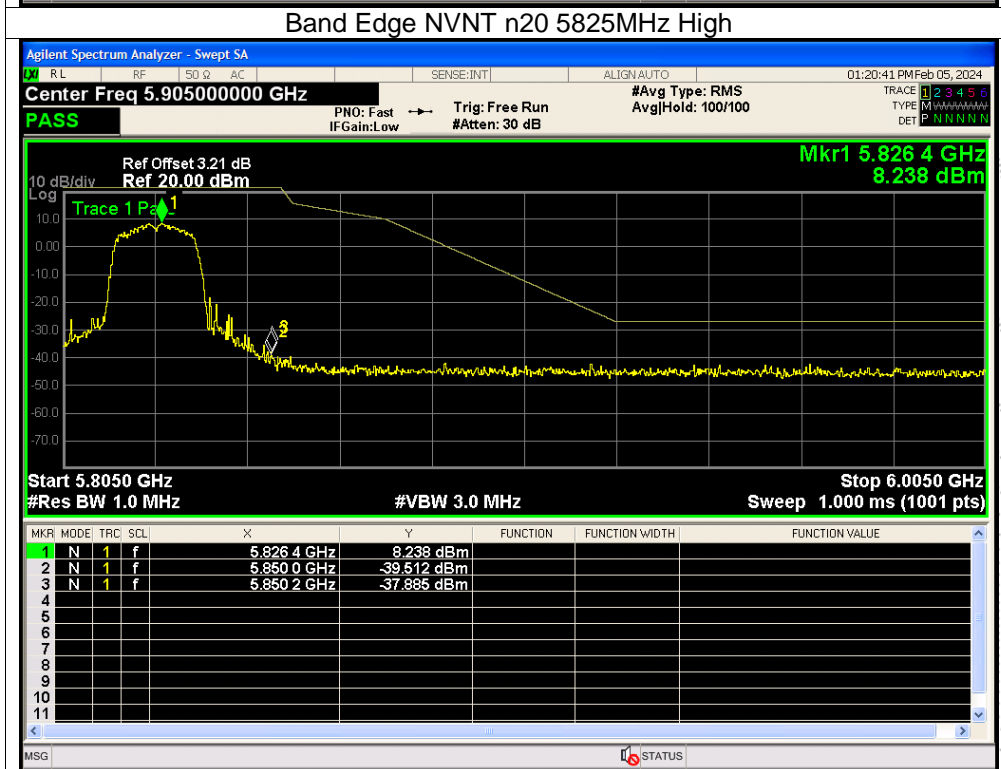
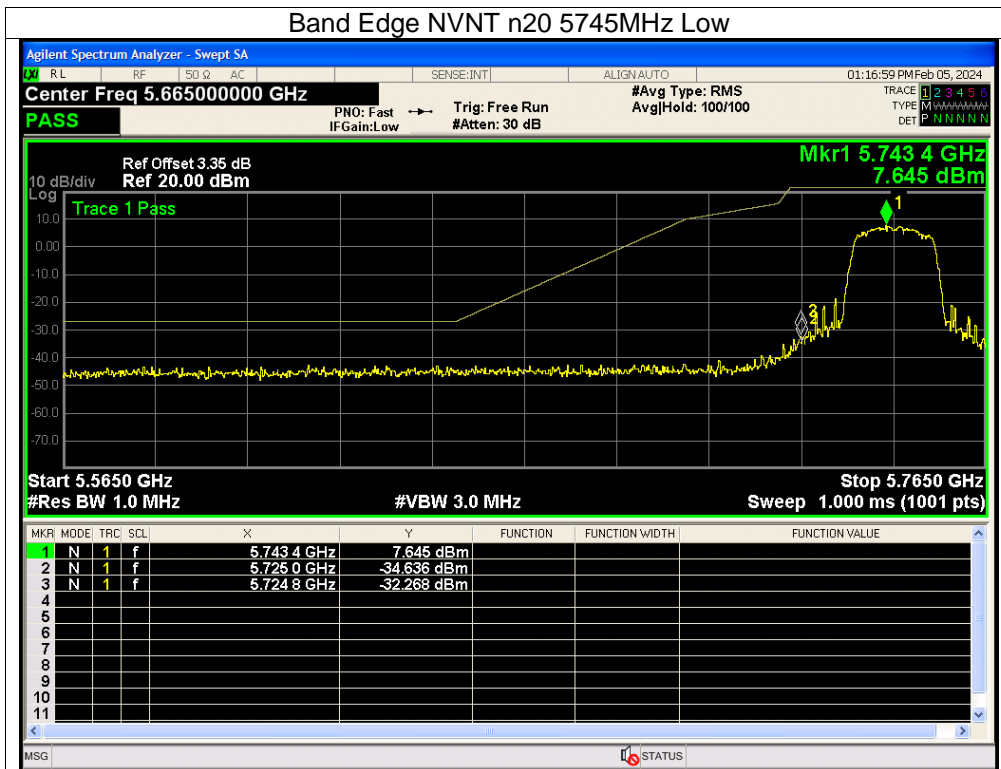

12. Spurious RF Conducted Emissions

12.1 Block Diagram Of Test Setup



12.2 Limit

Undesirable emission limits. Except as shown in paragraph (b)(7) of this section, the maximum emissions outside of the frequency bands of operation shall be attenuated in accordance with the following limits:

(1) For transmitters operating in the 5.15-5.25 GHz band: All emissions outside of the 5.15-5.35 GHz band shall not exceed an e.i.r.p. of -27 dBm/MHz.

(2) For transmitters operating in the 5.725-5.85 GHz band(i) All emissions shall be limited to a level of -27 dBm/MHz at 75 MHz or more above or below the band edge increasing linearly to 10 dBm/MHz at 25 MHz above or below the band edge, and from 25 MHz above or below the band edge increasing linearly to a level of 15.6 dBm/MHz at 5 MHz above or below the band edge, and from 5 MHz above or below the band edge increasing linearly to a level of 27 dBm/MHz at the band edge..

12.3 Test Procedure

1. Check the calibration of the measuring instrument using either an internal calibrator or a known signal from an external generator.
2. Position the EUT without connection to measurement instrument. Turn on the EUT and connect its antenna terminal to measurement instrument via a low loss cable. Then set it to any one measured frequency within its operating range, and make sure the instrument is operated in its linear range.
3. Set RBW of spectrum analyzer to 1 MHz with a convenient frequency span.
4. Measure the highest amplitude appearing on spectral display and set it as a reference level. Plot the graph with marking the highest point and edge frequency.
5. Repeat above procedures until all measured frequencies were complete.

12.4 Test Result

Remark: The measurement frequency range is from 9KHz to the 10th harmonic of the fundamental frequency. The lowest, middle and highest channels are tested to verify the spurious emissions and bandege measurement data.

About:26.5GHz-40GHz, The amplitude of spurious emissions which are attenuated by more than 20dB below the permissible value has no need to be reported.

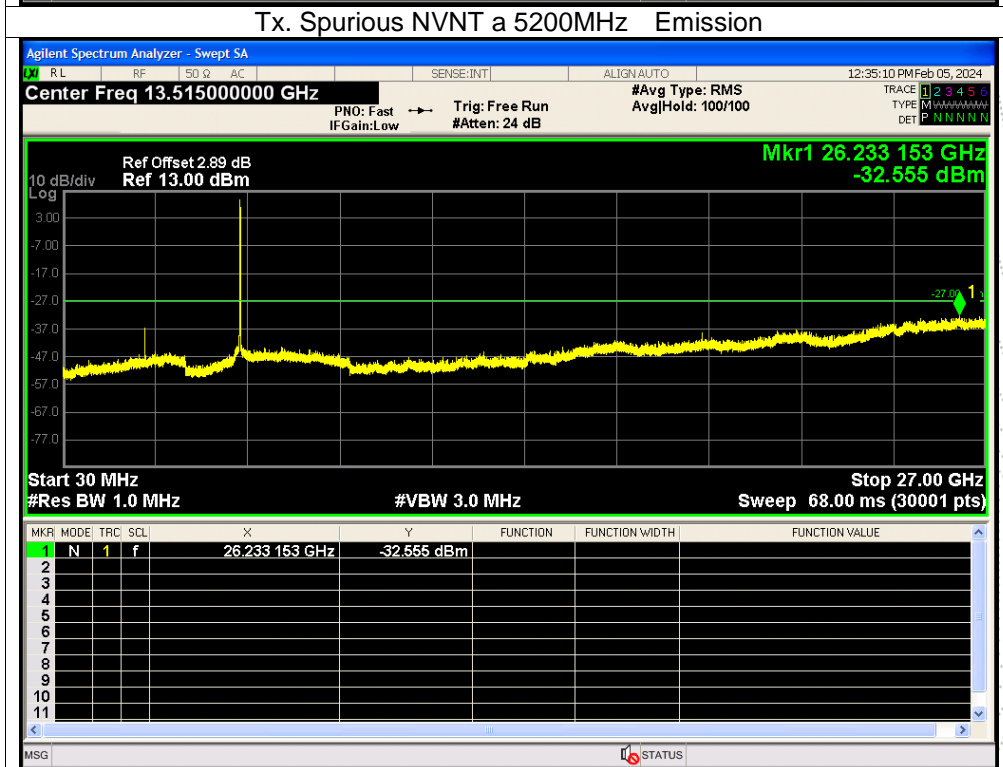
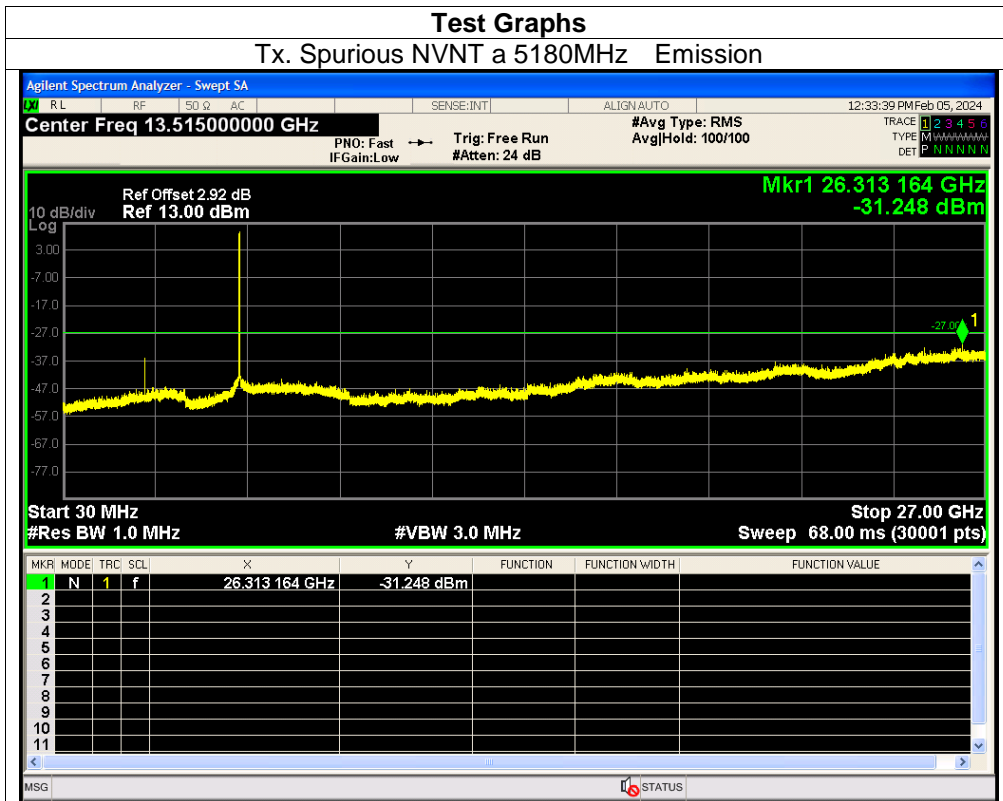

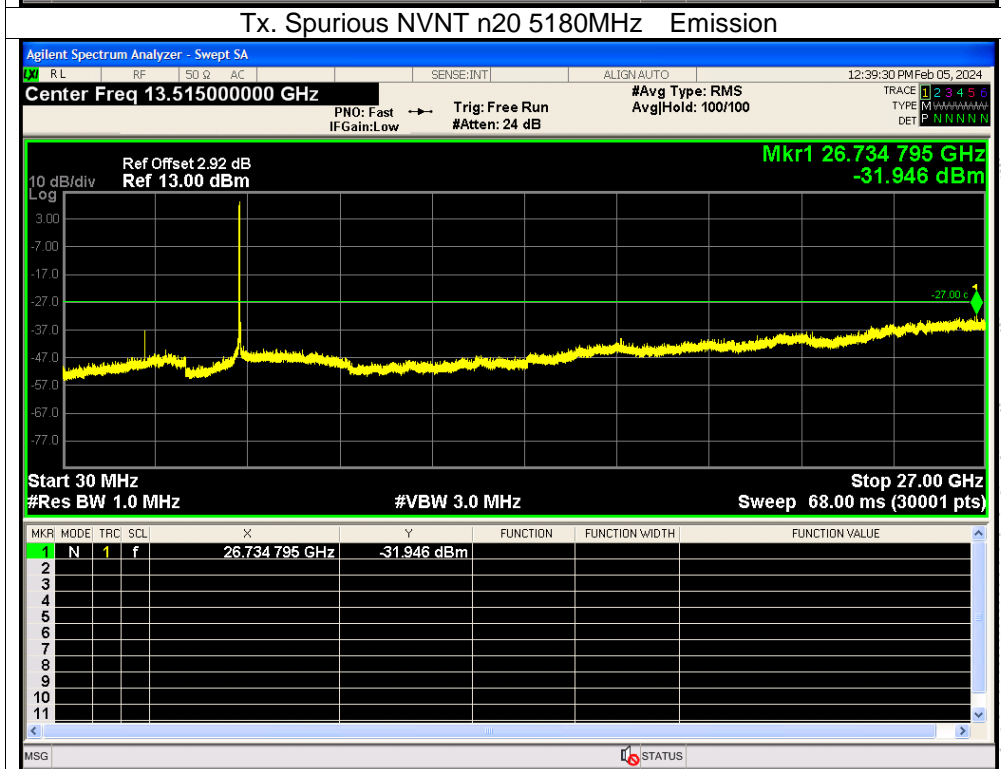
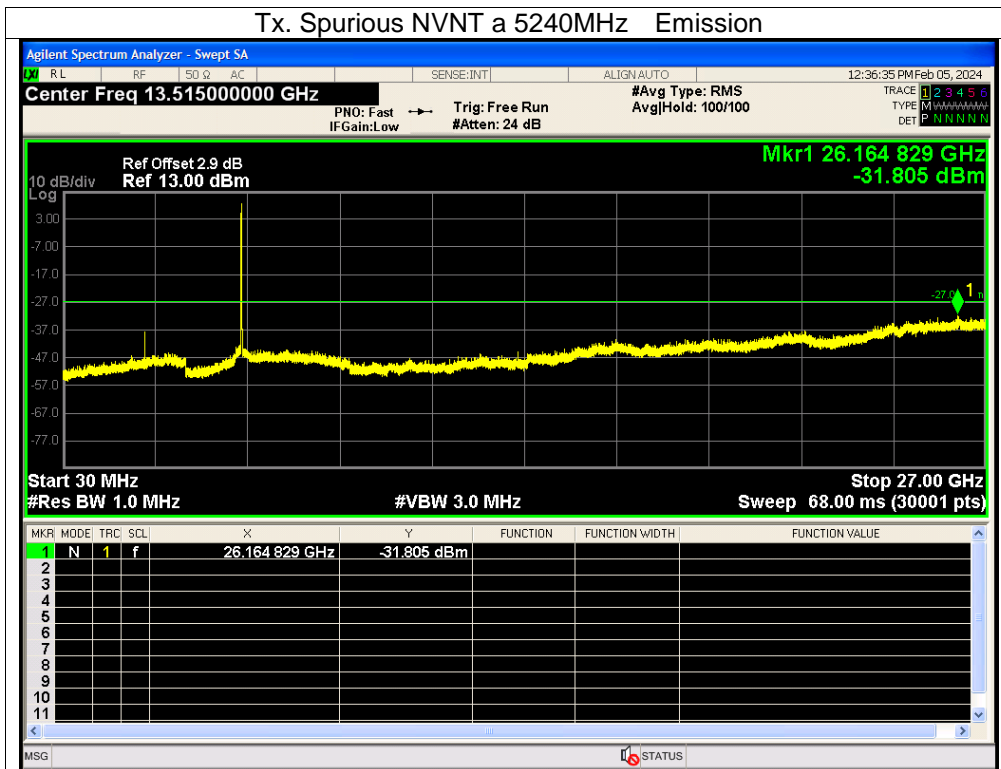

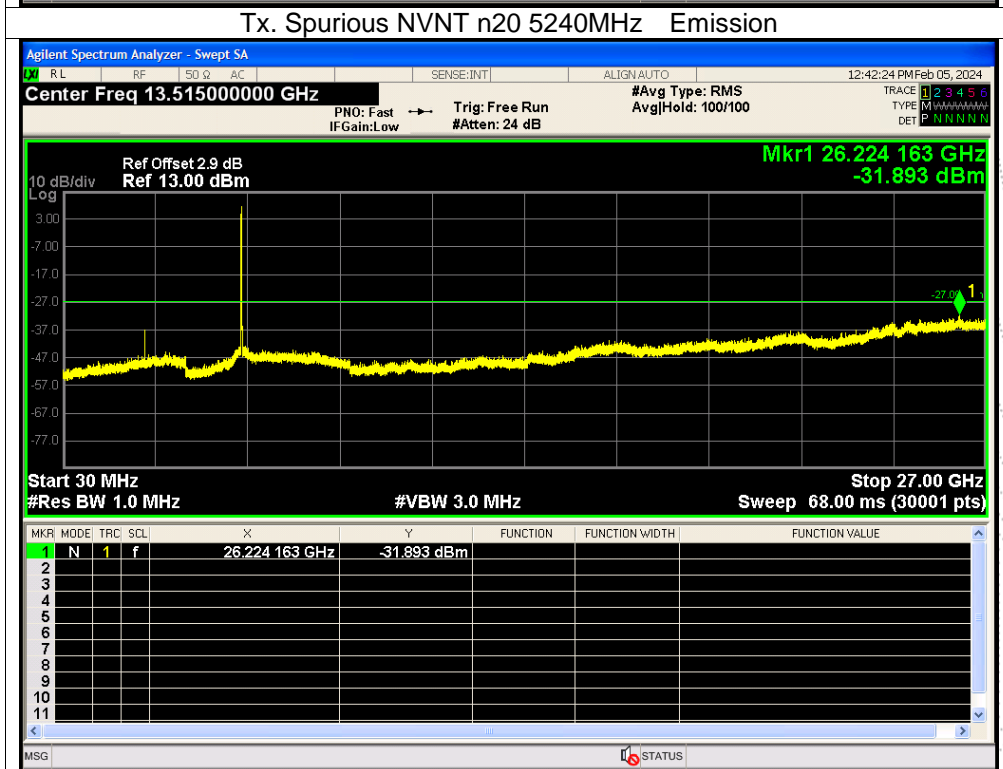
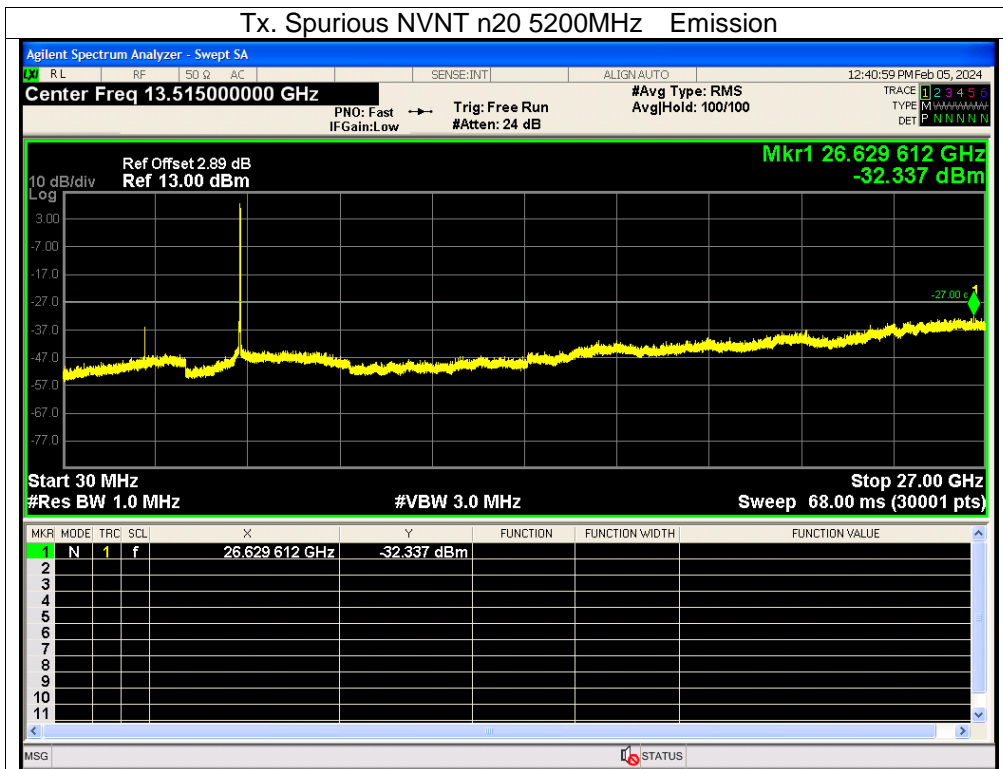

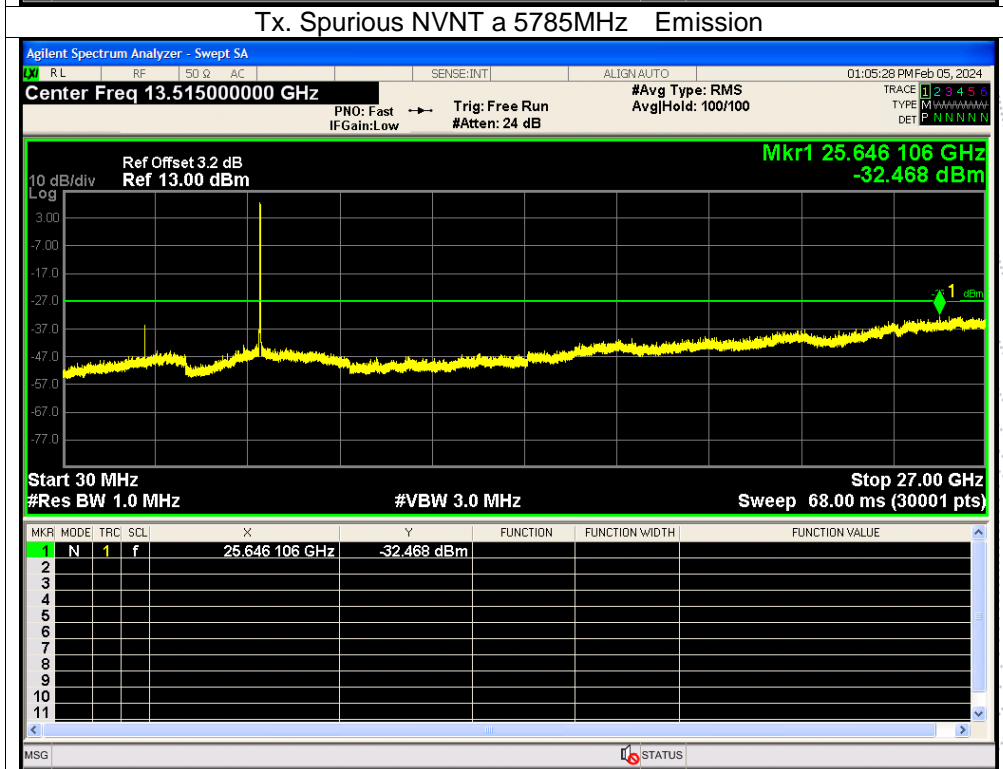
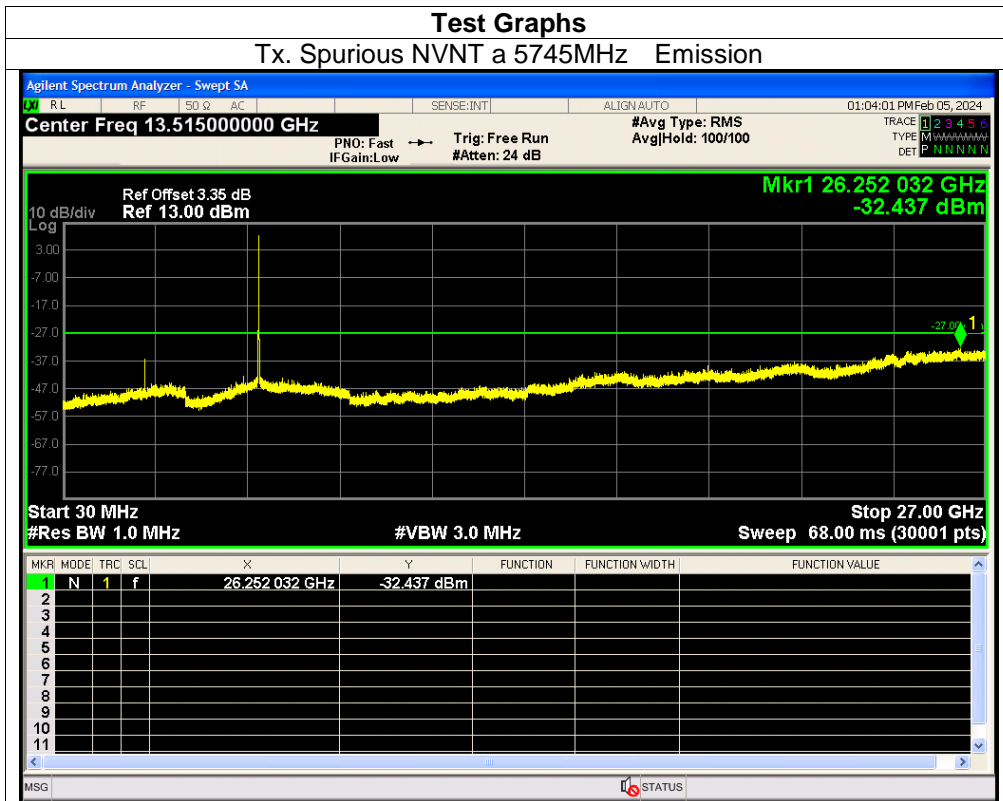

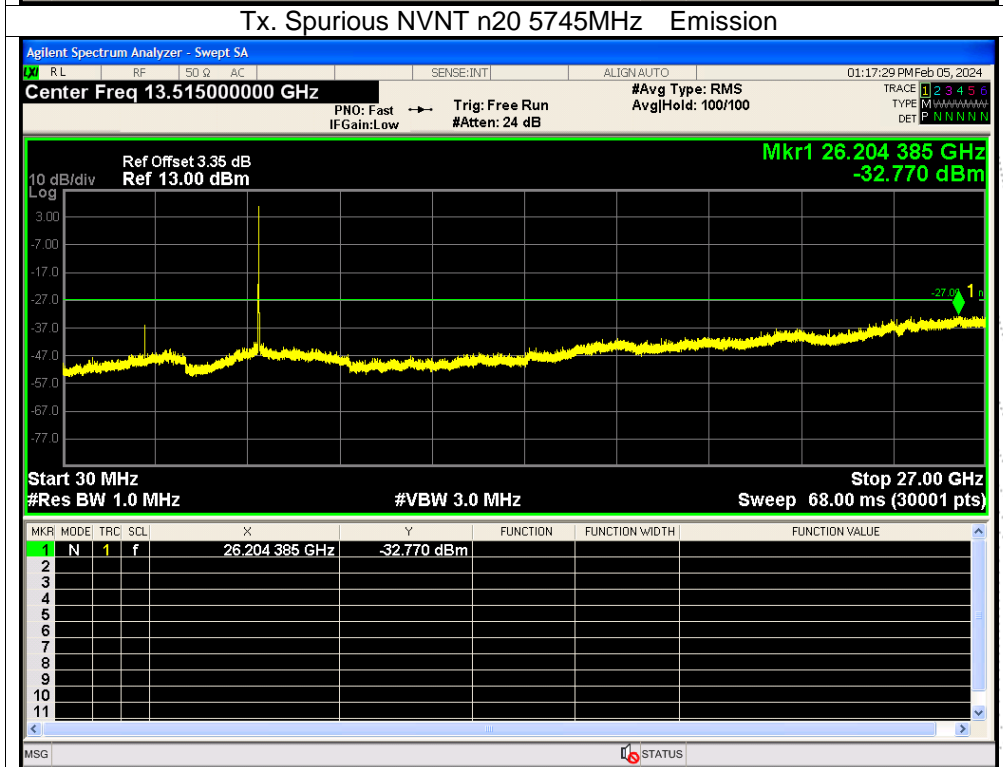
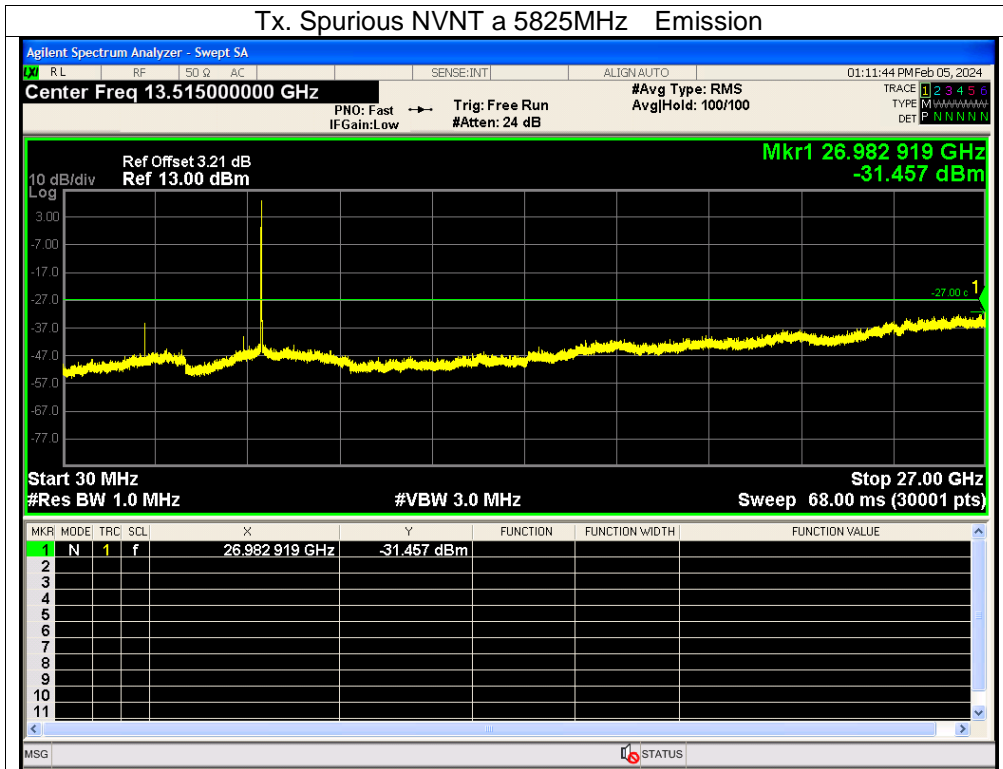

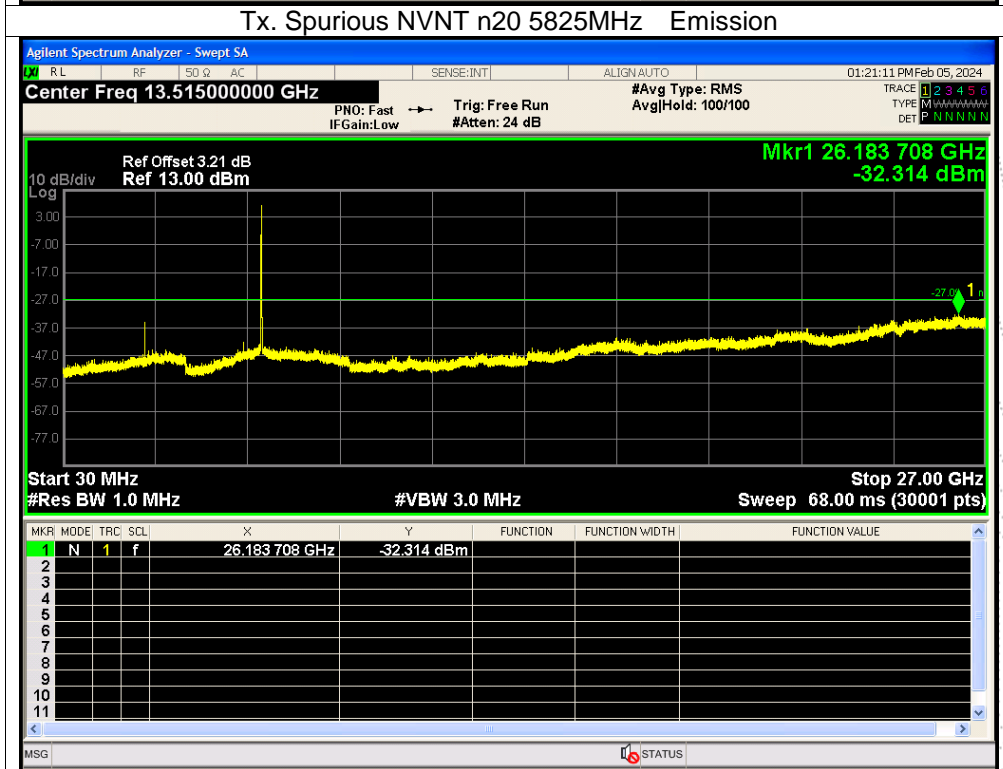
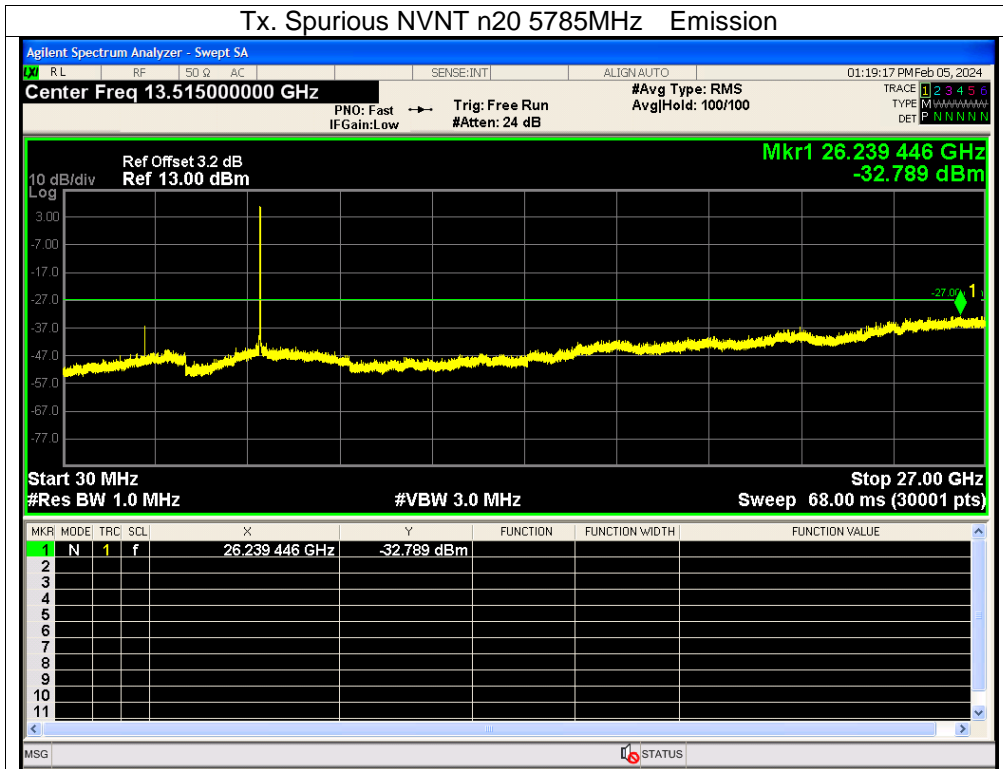

13. Frequency Stability Measurement

13.1 Block Diagram Of Test Setup



13.2 Limit

Manufactures of U-NII devices are responsible for ensuring frequency stability such that an emission is maintained within the band of operation under all conditions of normal operation as specified in the user's manual.

The transmitter center frequency tolerance shall be ± 20 ppm maximum for the 5 GHz band (IEEE 802.11n specification)..

13.3 Test Procedure

1. The transmitter output (antenna port) was connected to the spectrum analyzer.
2. EUT have transmitted absence of modulation signal and fixed channelize.
3. Set the spectrum analyzer span to view the entire absence of modulation emissions bandwidth.
4. Set RBW = 10 kHz, VBW = 10 kHz with peak detector and maxhold settings.
5. f_c is declaring of channel frequency. Then the frequency error formula is $(f_c - f) / f_c \times 10^6$ ppm and he limit is less than ± 20 ppm (IEEE 802.11n specification).
6. The test extreme voltage is to change the primary supply voltage from 85 to 115 percent of the nominal value
7. Extreme temperature is $-20^\circ\text{C} \sim 70^\circ\text{C}$.

13.4 Test Result

Temperature:	26 °C	Relative Humidity:	54%
Pressure:	101KPa	Test Voltage:	AC 120V/60Hz
Test Mode:	TX (5.1G) Mode Frequency U-NII-1 (5180-5240MHz)		

Voltage vs. Frequency Stability

TEST CONDITIONS				Reference Frequency: 5180MHz			
				f	fc	Max. Deviation (MHz)	Max. Deviation (ppm)
T nom (°C)	20	V nom (V)	120.00	5180.0010	5180	0.0010	0.1931
		V max (V)	138.00	5180.0031	5180	0.0031	0.5985
		V min (V)	102.00	5180.0122	5180	0.0122	2.3552
Limits				5150-5250 MHz			
Result				Complies			

Temperature vs. Frequency Stability

TEST CONDITIONS				Reference Frequency: 5180MHz			
				f	fc	Max. Deviation (MHz)	Max. Deviation (ppm)
V nom (V)	120	T (°C)	-20	5180.0115	5180	0.0115	2.2201
		T (°C)	-10	5180.0043	5180	0.0043	0.8301
		T (°C)	0	5180.0097	5180	0.0097	1.8726
		T (°C)	10	5180.0059	5180	0.0059	1.1390
		T (°C)	20	5180.0113	5180	0.0113	2.1815
		T (°C)	30	5180.0065	5180	0.0065	1.2548
		T (°C)	40	5180.0125	5180	0.0125	2.4131
		T (°C)	50	5180.0013	5180	0.0013	0.2510
		T (°C)	60	5180.0027	5180	0.0027	0.5212
		T (°C)	70	5180.0115	5180	0.0115	2.2201
Limits				5150-5250 MHz			
Result				Complies			

Voltage vs. Frequency Stability

TEST CONDITIONS				Reference Frequency: 5200MHz			
				f	fc	Max. Deviation (MHz)	Max. Deviation (ppm)
T nom (°C)	20	V nom (V)	120.00	5200.0027	5200	0.0027	0.5192
		V max (V)	138.00	5200.0133	5200	0.0133	2.5577
		V min (V)	102.00	5200.0069	5200	0.0069	1.3269
Limits				5725-5850 MHz			
Result				Complies			

Temperature vs. Frequency Stability

TEST CONDITIONS				Reference Frequency: 5200MHz			
				f	fc	Max. Deviation (MHz)	Max. Deviation (ppm)
V nom (V)	120	T (°C)	-20	5200.00470	5200	0.00470	0.9038
		T (°C)	-10	5200.00480	5200	0.00480	0.9231
		T (°C)	0	5200.00790	5200	0.00790	1.5192
		T (°C)	10	5200.01110	5200	0.01110	2.1346
		T (°C)	20	5200.00460	5200	0.00460	0.8846
		T (°C)	30	5200.00430	5200	0.00430	0.8269
		T (°C)	40	5200.00430	5200	0.00430	0.8269
		T (°C)	50	5200.00250	5200	0.00250	0.4808
		T (°C)	60	5200.00990	5200	0.00990	1.9038
		T (°C)	70	5200.01170	5200	0.01170	2.2500
Limits				5150-5250 MHz			
Result				Complies			

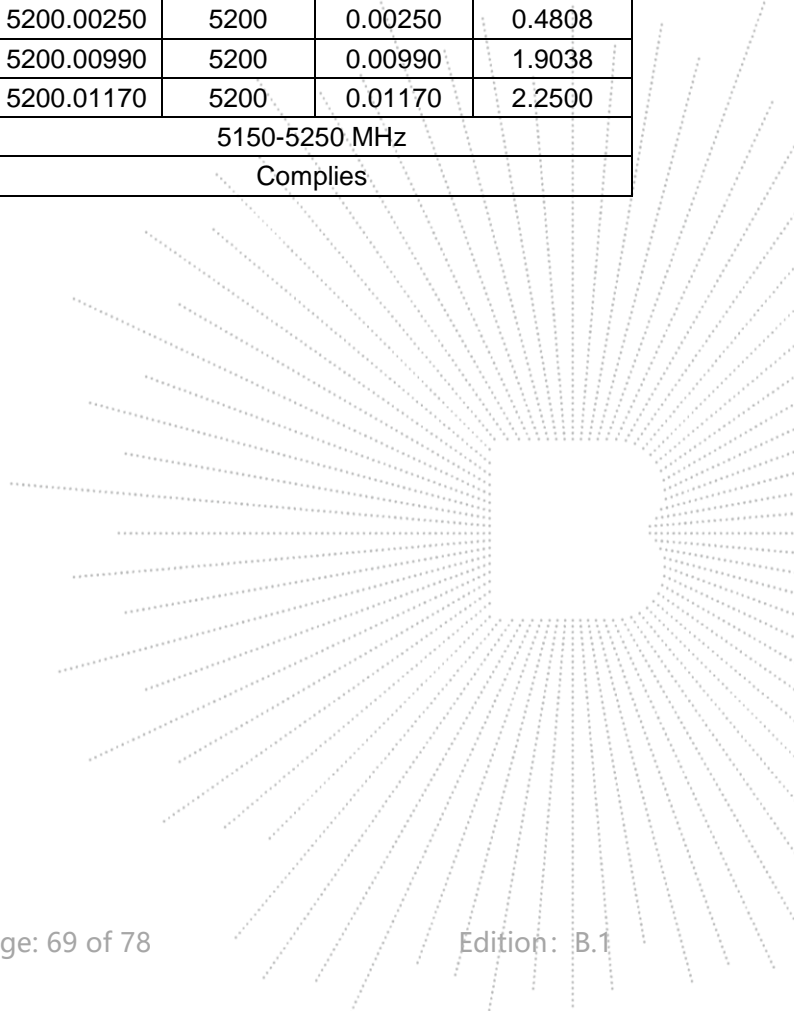

Voltage vs. Frequency Stability

TEST CONDITIONS				Reference Frequency: 5240MHz			
				f	fc	Max. Deviation (MHz)	Max. Deviation (ppm)
T nom (°C)	20	V nom (V)	120.00	5240.0085	5240	0.0085	1.6221
		V max (V)	138.00	5240.0104	5240	0.0104	1.9847
		V min (V)	102.00	5240.0038	5240	0.0038	0.7252
Limits				5150-5250 MHz			
Result				Complies			

Temperature vs. Frequency Stability

TEST CONDITIONS				Reference Frequency: 5240MHz			
				f	fc	Max. Deviation (MHz)	Max. Deviation (ppm)
V nom (V)	120	T (°C)	-20	5240.0031	5240	0.0031	0.5916
		T (°C)	-10	5240.0028	5240	0.0028	0.5344
		T (°C)	0	5240.0101	5240	0.0101	1.9275
		T (°C)	10	5240.0024	5240	0.0024	0.4580
		T (°C)	20	5240.0086	5240	0.0086	1.6412
		T (°C)	30	5240.0029	5240	0.0029	0.5534
		T (°C)	40	5240.0090	5240	0.0090	1.7176
		T (°C)	50	5240.0084	5240	0.0084	1.6031
		T (°C)	60	5240.0131	5240	0.0131	2.5000
		T (°C)	70	5240.0098	5240	0.0098	1.8702
Limits				5150-5250 MHz			
Result				Complies			

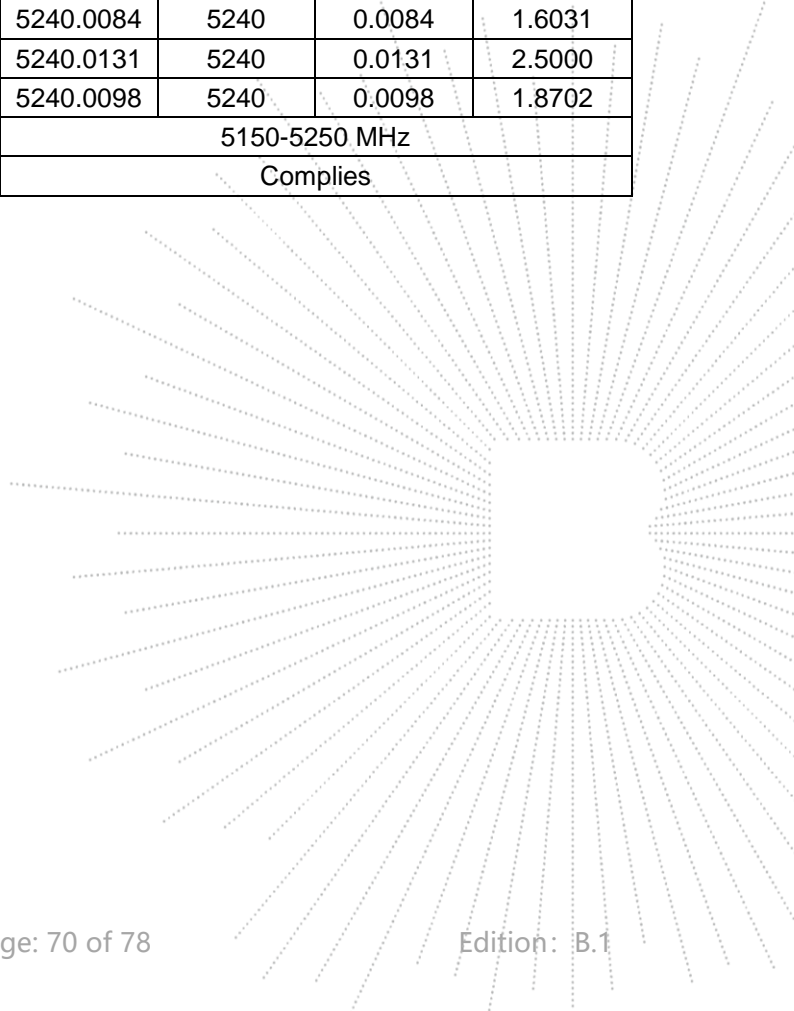

Temperature:	26 °C	Relative Humidity:	54%
Pressure:	101KPa	Test Voltage:	AC 120V/60Hz
Test Mode:	TX (5.8G) Mode Frequency U-NII-3 (5745-5825MHz)		

Voltage vs. Frequency Stability

TEST CONDITIONS				Reference Frequency: 5745MHz			
				f	fc	Max. Deviation (MHz)	Max. Deviation (ppm)
T nom (°C)	20	V nom (V)	120.00	5745.01290	5745	0.01290	2.2454
		V max (V)	138.00	5745.00150	5745	0.00150	0.2611
		V min (V)	102.00	5745.01040	5745	0.01040	1.8103
Limits				5725-5850 MHz			
Result				Complies			

Temperature vs. Frequency Stability

TEST CONDITIONS				Reference Frequency: 5745MHz			
				f	fc	Max. Deviation (MHz)	Max. Deviation (ppm)
V nom (V)	120	T (°C)	-20	5745.01040	5745	0.01040	1.8103
		T (°C)	-10	5745.00180	5745	0.00180	0.3133
		T (°C)	0	5745.00270	5745	0.00270	0.4700
		T (°C)	10	5745.00750	5745	0.00750	1.3055
		T (°C)	20	5745.01240	5745	0.01240	2.1584
		T (°C)	30	5745.00960	5745	0.00960	1.6710
		T (°C)	40	5745.00990	5745	0.00990	1.7232
		T (°C)	50	5745.00860	5745	0.00860	1.4970
		T (°C)	60	5745.00620	5745	0.00620	1.0792
		T (°C)	70	5745.00360	5745	0.00360	0.6266
Limits				5725-5850 MHz			
Result				Complies			

Voltage vs. Frequency Stability

TEST CONDITIONS				Reference Frequency: 5785MHz			
				f	fc	Max. Deviation (MHz)	Max. Deviation (ppm)
T nom (°C)	20	V nom (V)	120.00	5785.01170	5785	0.01170	2.0225
		V max (V)	138.00	5785.00680	5785	0.00680	1.1755
		V min (V)	102.00	5785.00370	5785	0.00370	0.6396
Limits				5725-5850 MHz			
Result				Complies			

Temperature vs. Frequency Stability

TEST CONDITIONS				Reference Frequency: 5785MHz			
				f	fc	Max. Deviation (MHz)	Max. Deviation (ppm)
V nom (V)	120	T (°C)	-20	5785.00210	5785	0.00210	0.3630
		T (°C)	-10	5785.00180	5785	0.00180	0.3111
		T (°C)	0	5785.01320	5785	0.01320	2.2818
		T (°C)	10	5785.00360	5785	0.00360	0.6223
		T (°C)	20	5785.00680	5785	0.00680	1.1755
		T (°C)	30	5785.00130	5785	0.00130	0.2247
		T (°C)	40	5785.00010	5785	0.00010	0.0173
		T (°C)	50	5785.00670	5785	0.00670	1.1582
		T (°C)	60	5785.00470	5785	0.00470	0.8124
		T (°C)	70	5785.00700	5785	0.00700	1.2100
Limits				5725-5850 MHz			
Result				Complies			

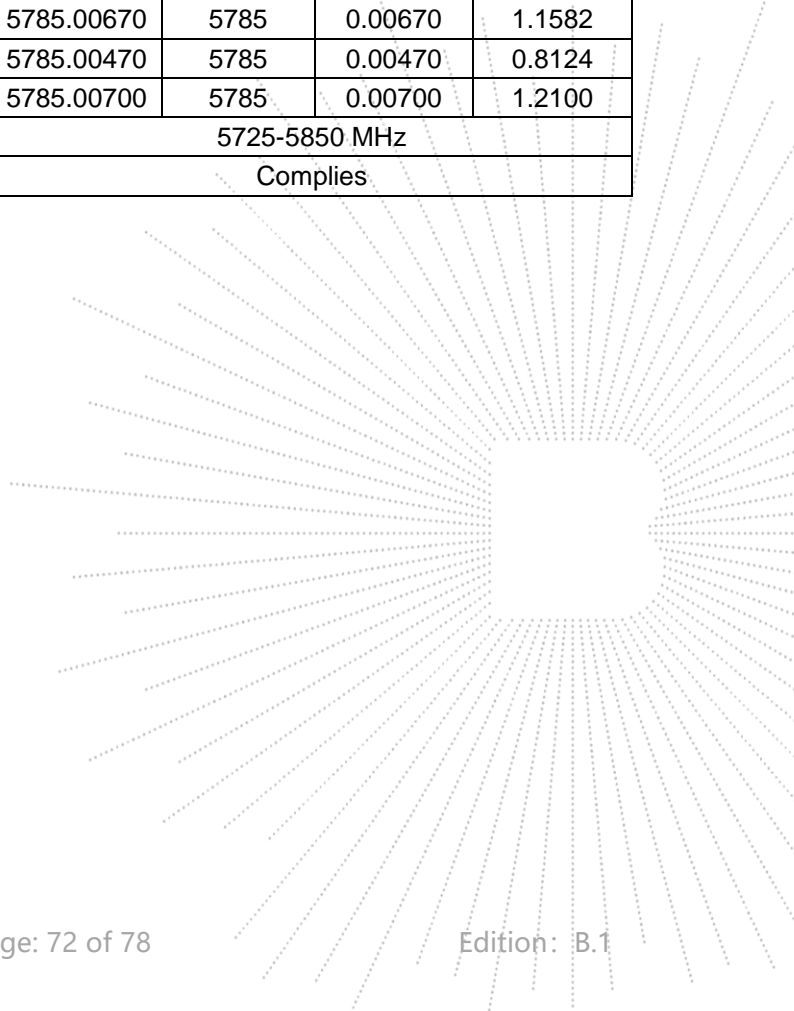

Voltage vs. Frequency Stability

TEST CONDITIONS				Reference Frequency : 5825MHz			
				f	fc	Max. Deviation (MHz)	Max. Deviation (ppm)
T nom (°C)	20	V nom (V)	120.00	5825.01150	5825	0.01150	1.9742
		V max (V)	138.00	5825.00670	5825	0.00670	1.1502
		V min (V)	102.00	5825.00380	5825	0.00380	0.6524
Limits				5725-5850 MHz			
Result				Complies			

Temperature vs. Frequency Stability

TEST CONDITIONS				Reference Frequency : 5825MHz			
				f	fc	Max. Deviation (MHz)	Max. Deviation (ppm)
V nom (V)	120	T (°C)	-20	5825.00420	5825	0.00420	0.7210
		T (°C)	-10	5825.00790	5825	0.00790	1.3562
		T (°C)	0	5825.00140	5825	0.00140	0.2403
		T (°C)	10	5825.01310	5825	0.01310	2.2489
		T (°C)	20	5825.00980	5825	0.00980	1.6824
		T (°C)	30	5825.00230	5825	0.00230	0.3948
		T (°C)	40	5825.00890	5825	0.00890	1.5279
		T (°C)	50	5825.00300	5825	0.00300	0.5150
		T (°C)	60	5825.01240	5825	0.01240	2.1288
		T (°C)	70	5825.00120	5825	0.00120	0.2060
Limits				5725-5850 MHz			
Result				Complies			

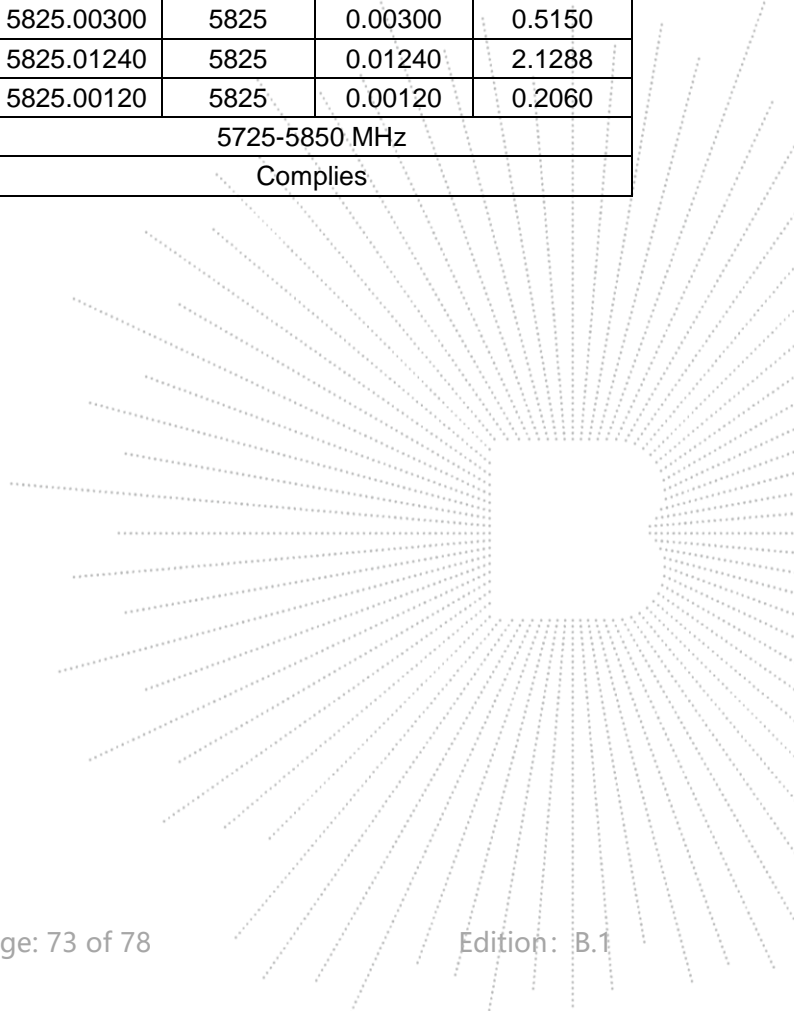

14. Antenna Requirement

14.1 Limit

15.203 requirement: For intentional device, according to 15.203: an intentional radiator shall be designed to ensure that no antenna other than that furnished by the responsible party shall be used with the device.

14.2 Test Result

The EUT antenna is Internal antenna (antenna gain: 4.35 dBi). It comply with the standard requirement.

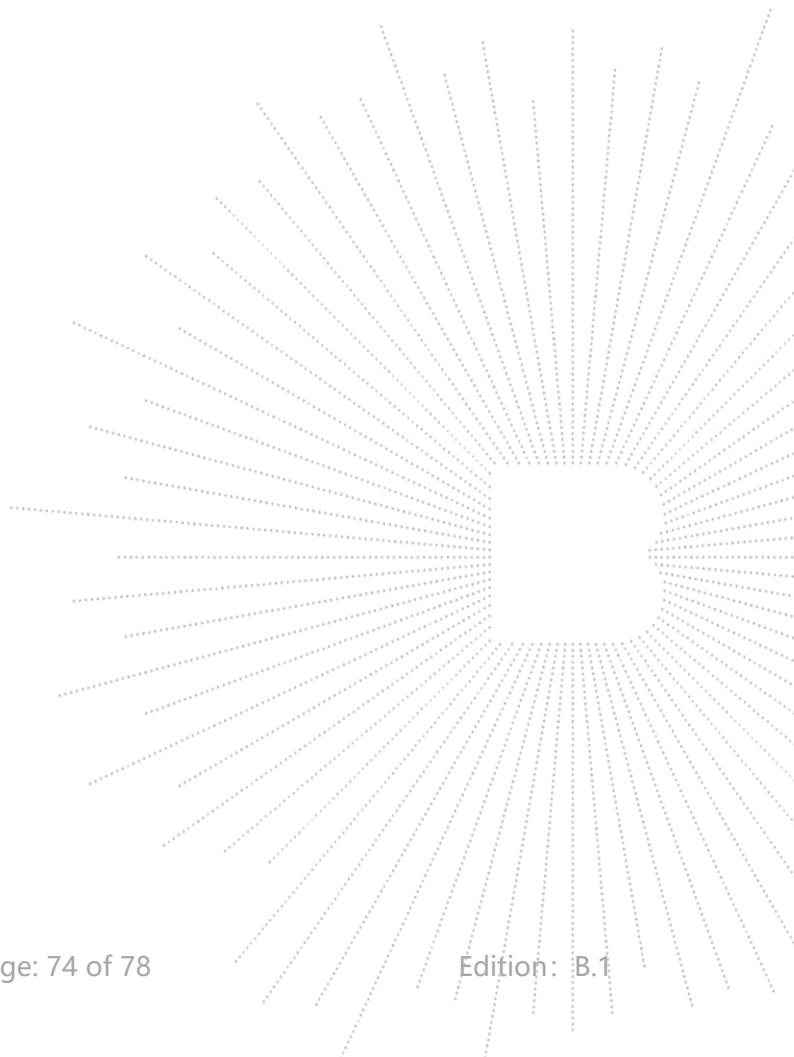

15. EUT Photographs

EUT Photo 1



EUT Photo 2



NOTE: Appendix-Photographs Of EUT Constructional Details

16. EUT Test Setup Photographs

Conducted Measurement Photo

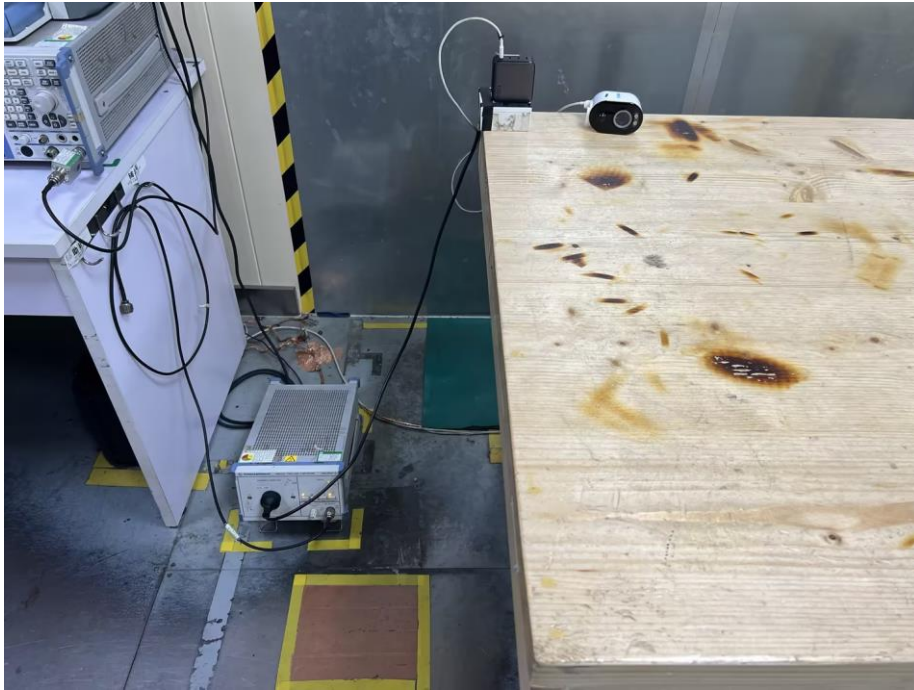

Radiated Measurement Photos

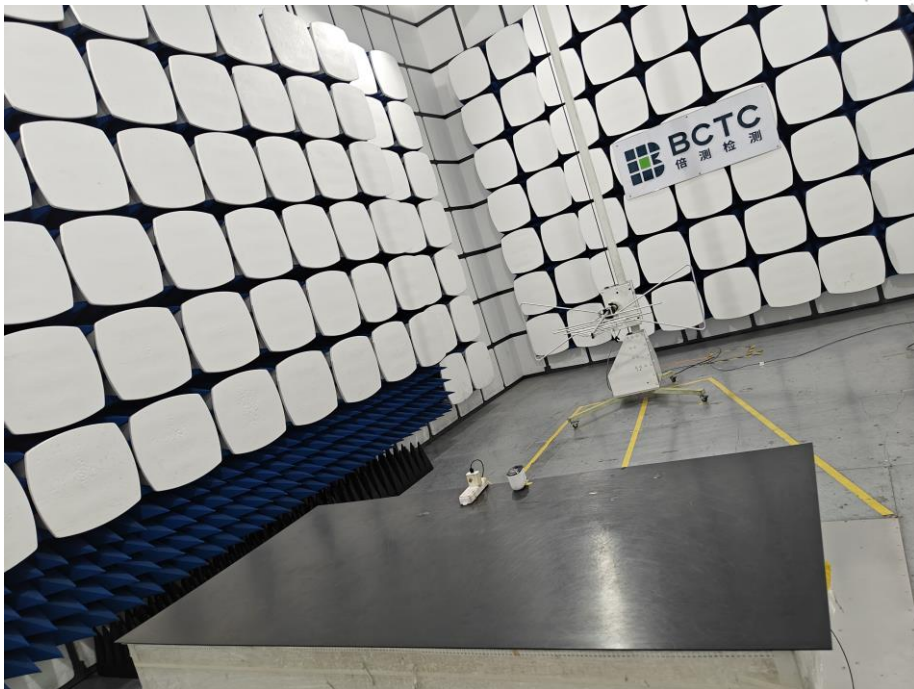

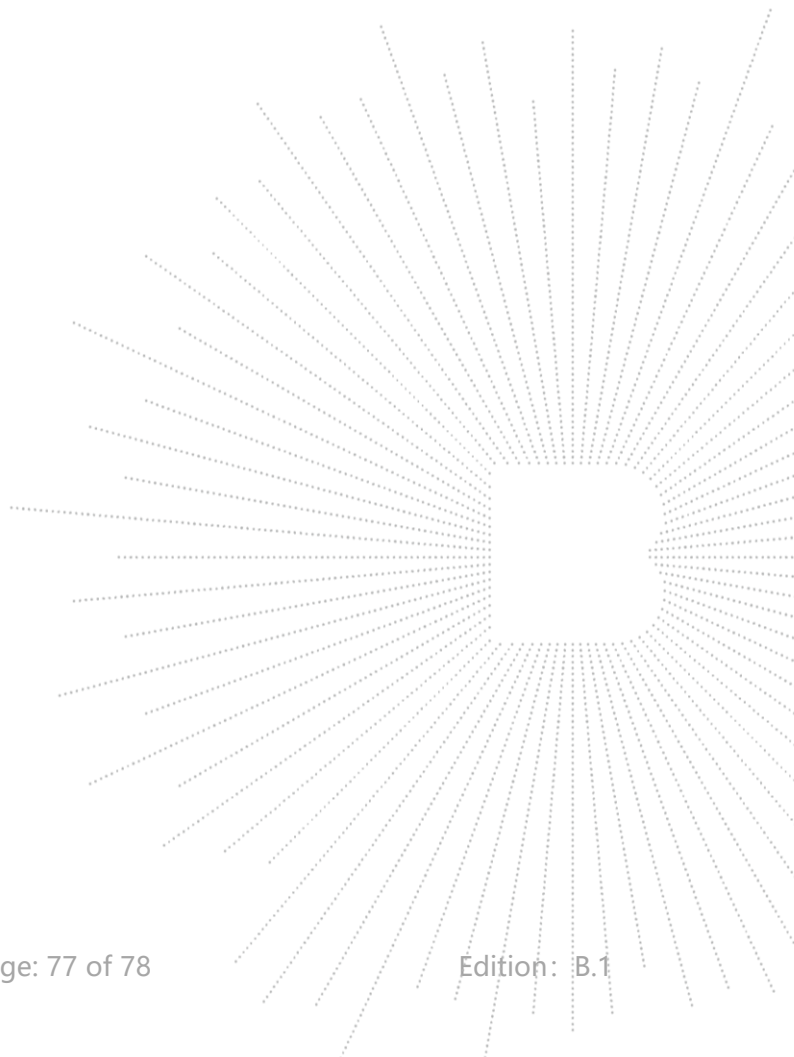

STATEMENT

1. The equipment lists are traceable to the national reference standards.
2. The test report can not be partially copied unless prior written approval is issued from our lab.
3. The test report is invalid without the "special seal for inspection and testing".
4. The test report is invalid without the signature of the approver.
5. The test process and test result is only related to the Unit Under Test.
6. Sample information is provided by the client and the laboratory is not responsible for its authenticity.
7. The quality system of our laboratory is in accordance with ISO/IEC17025.
8. If there is any objection to this test report, the client should inform issuing laboratory within 15 days from the date of receiving test report.

Address:

1-2/F., Building B, Pengzhou Industrial Park, No.158, Fuyuan 1st Road, Zhancheng, Fuhai Subdistrict, Bao'an District, Shenzhen, Guangdong, China

TEL: 400-788-9558

P.C.: 518103

FAX: 0755-33229357

Website: <http://www.chnbctc.com>

E-Mail: bctc@bctc-lab.com.cn

***** END *****

