

J-FB

Enhanced Night Vision Binocular Goggles User Manual

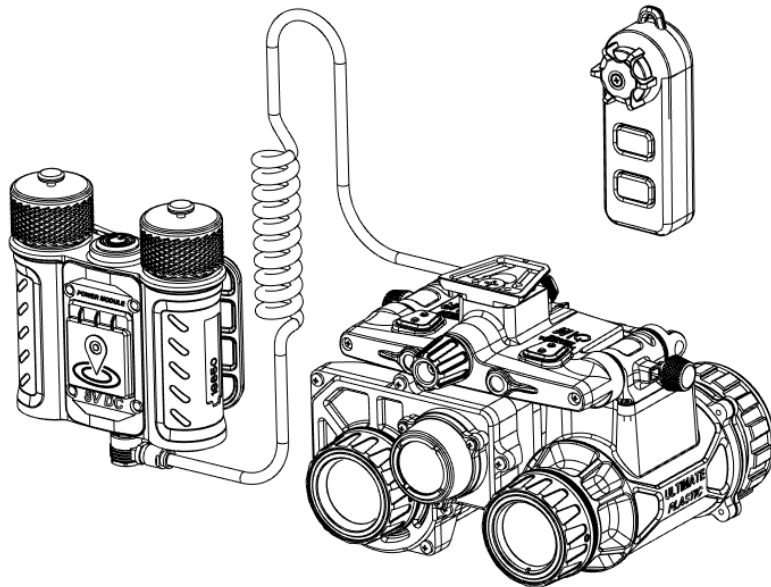

- Please read this manual carefully! Use and maintain the product according to the introduction
- The external optical surfaces should be clean at all times. Touching the optical surfaces with bare hands is not recommended.
- Sand and sea water can damage the optical coatings!
- Do not point the device directly at the sun!
- Image performance is dependent on scenery and atmosphere conditions.
- External sensor performance depends on environmental and atmospheric conditions.
- When the battery is not used for a long time, please remove it and save it independently
- When carrying or transporting the device, put the protective lens cap!
- Clean the lens surfaces with the Lens Cloth or with the napkin!
- Hereby, [IRay Technology Co., Ltd.] declares that the radio equipment type [J-FB] is in compliance with directive 2014/53/EU and 2011/65/EU. The full text of the EU declaration of conformity is available at the following internet address: www.iraytek.com This device may be operated in all member states of the EU.
- Labeling requirements: This device complies with part 15 of the FCC Rules. Operation is subject to the following two conditions: (1) This device may not cause harmful interference, and (2) this device must accept any interference received, including interference that may cause undesired operation.

FCC Statement: FCC-ID: 2AYGT-JFB

- Information to user: Any Changes or modifications not expressly approved by the party responsible for compliance could void the user's authority to operate the equipment.
- Class B: Note: This equipment has been tested and found to comply with the limits for a Class B digital device, pursuant to part 15 of the FCC Rules. These limits are designed to provide reasonable protection against harmful interference in a residential installation. This equipment generates uses and can radiate radio frequency energy and, if not installed and used in accordance with the instructions, may cause harmful interference to radio communications. However, there is no guarantee that interference will not occur in a particular installation. If this equipment does cause harmful interference to radio or television reception, which can be determined by turning the equipment off and on, the user is encouraged to try to correct the interference by one or more of the following measures:
 - Reorient or relocate the receiving antenna.
 - Increase the separation between the equipment and receiver.
 - Connect the equipment into an outlet on a circuit different from that to which the receiver is connected.
 - Consult the dealer or an experienced radio/TV technician for help.

Note: The manufacturer is not responsible for any radio or TV interference caused by unauthorized modifications to this equipment. Such modifications could void the user's authority to operate the equipment.

Note: This equipment has been tested and found to comply with the limits for a Class B digital device, pursuant to part 15 of the FCC

Rules.



2012/19/EU (WEEE directive): Products marked with this symbol cannot be disposed of as unsorted municipal waste in the European Union. For proper recycling, return this product to your local supplier upon the purchase of equivalent new equipment, or dispose of it at designated collection points.

SUMMARY

J-FB is equipped with a new generation of night vision fusion technology, by which the binocular three-dimensional imaging and thermal imaging technology make it possible for users to recognize targets and distinguish threats quickly.

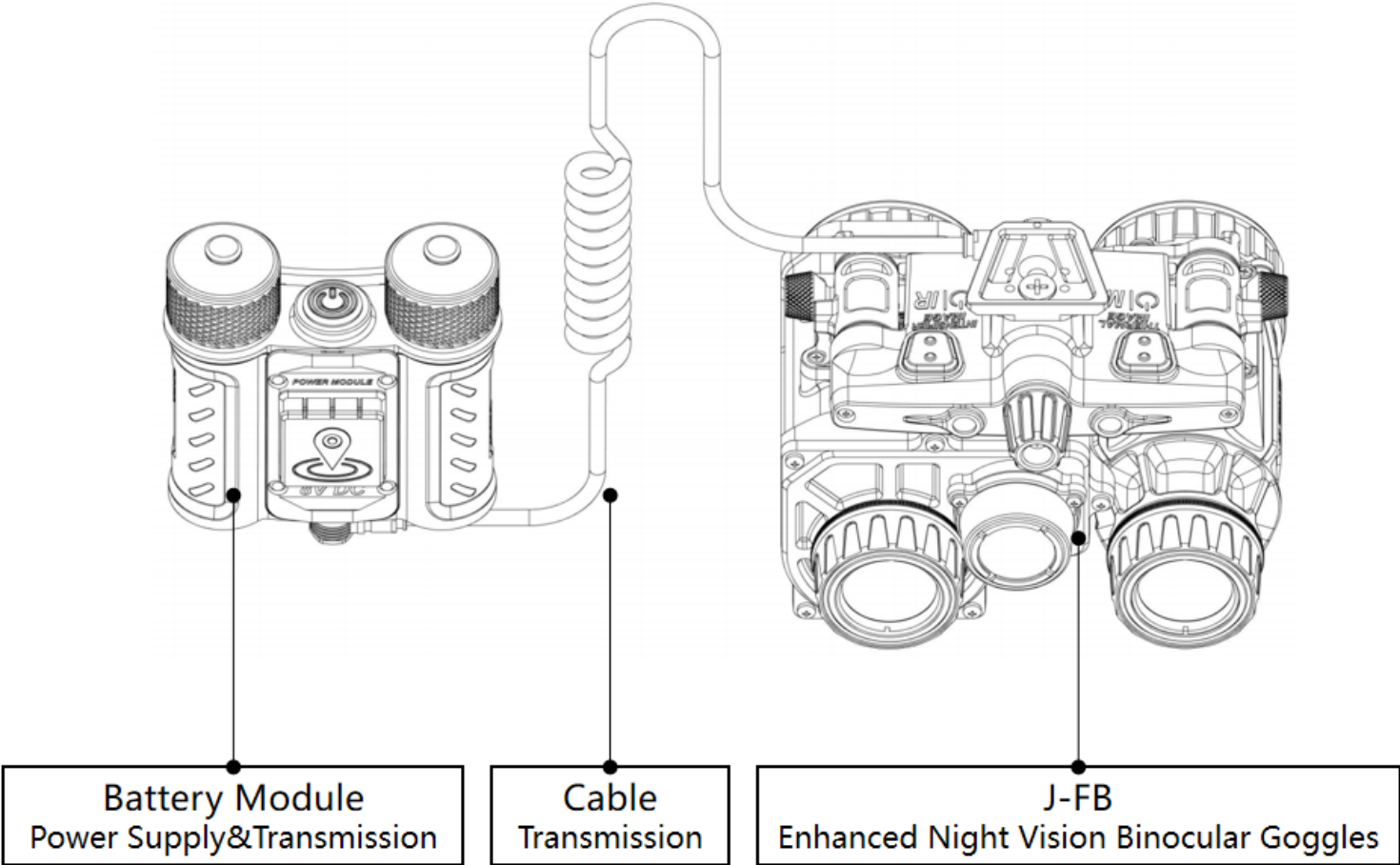

PACKING LIST

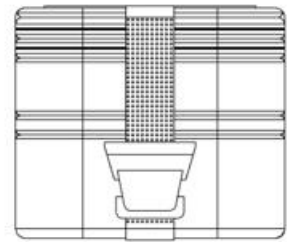
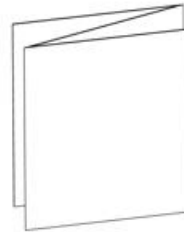
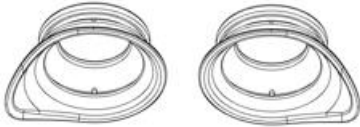
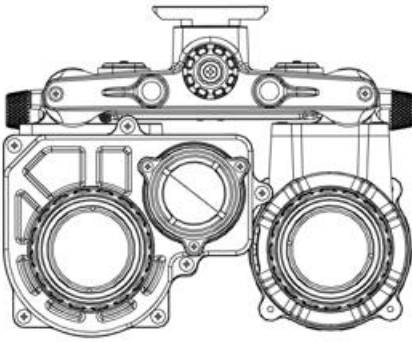

- 1 J-FB host
- 2 Battery module
- 3 Cable
- 4 Remote control
- 5 Patch
- 6 Accessories (gasket)
- 7 User manual
- 8 Nylon protective bag

APPEARANCE

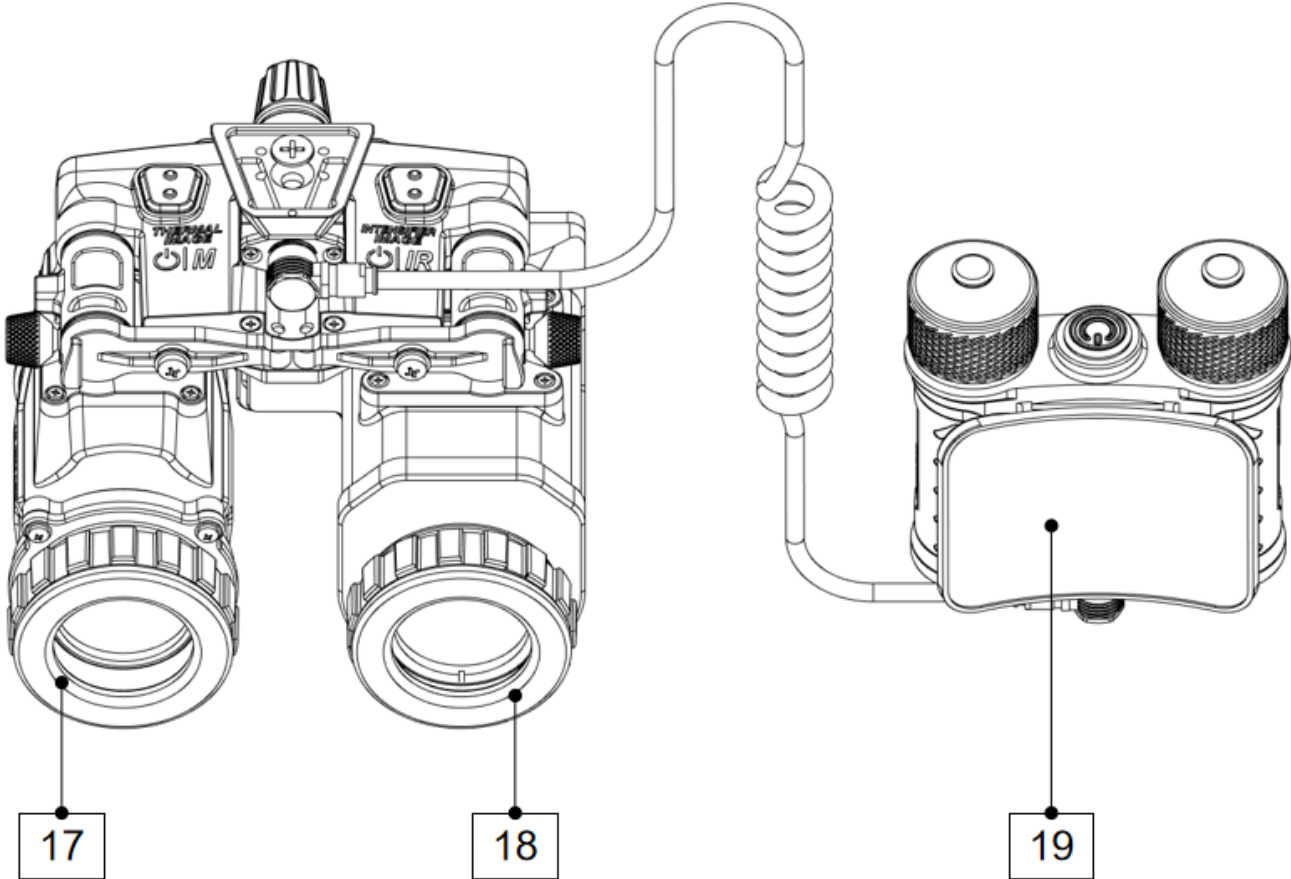
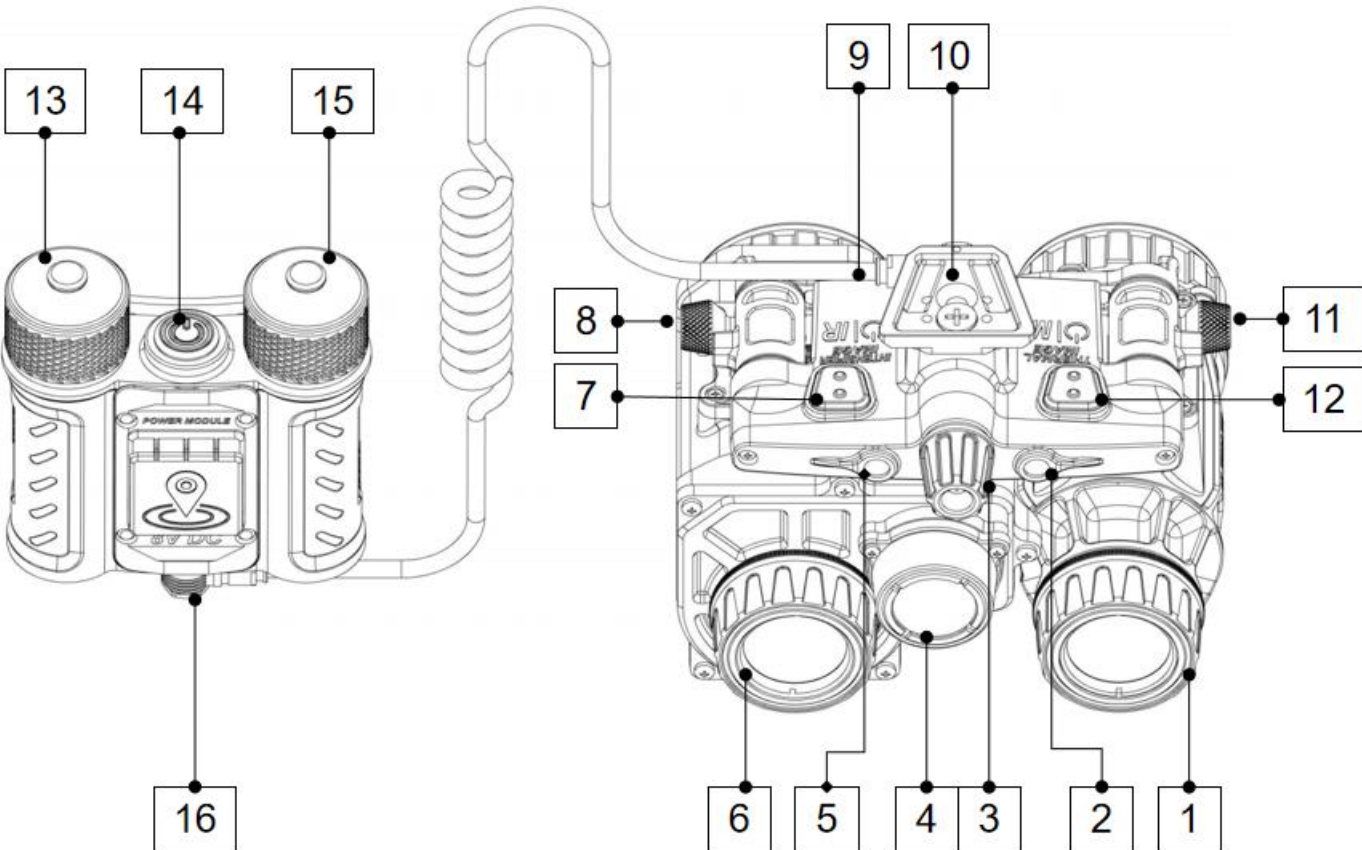

NOTE

All images used in this instruction manual are for illustrative purpose only. Actual product condition may vary.

- 1 Image Intensifier-Objective Lens (L)
- 2 Brightness Sensing Window
- 3 Function Control Knob
- 4 Thermal Image Objective Lens
- 5 IR Fill Window
- 6 Image Intensifier-Objective Lens (R)
- 7 Function Control Button (R)
- 8 IPD Knob (R)
- 9 Cable And Cable Access Port
- 10 L4G24 Bracket Interface
- 11 IPD Knob (L)
- 12 Function Control Button (L)
- 13 Battery Compartment - Battery Cover (R)
- 14 Battery Compartment - Switch
- 15 Battery Compartment - Battery Cover (L)
- 16 Cable And Cable Access Port
- 17 Eyepiece (L)
- 18 Eyepiece (R)
- 19 Battery Module (Hook And Loop)

INSTALLATION AND CONTROLS

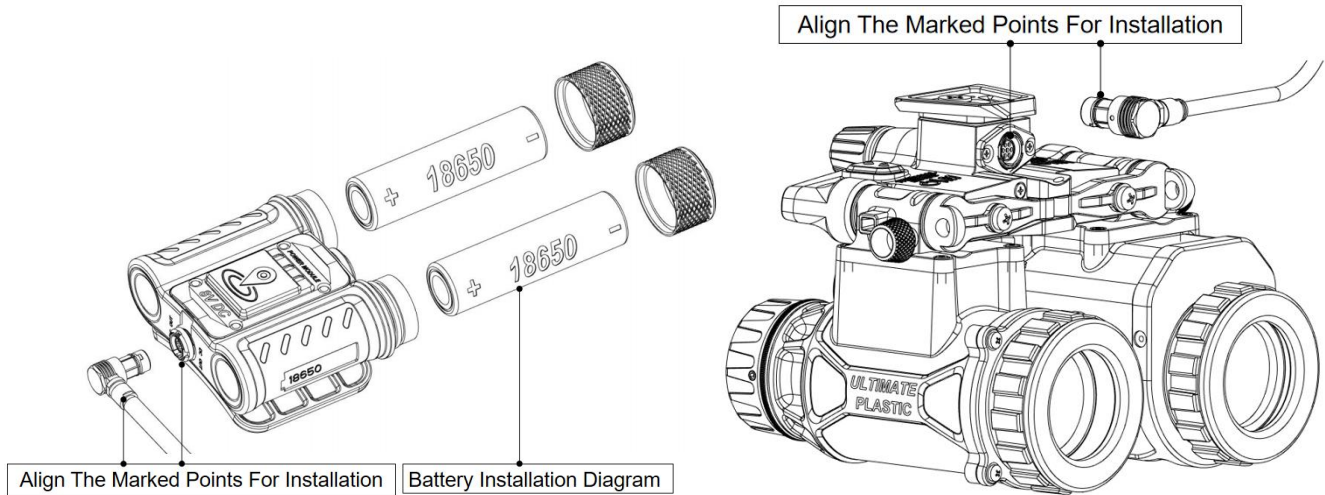

Please complete the installation of battery and cable as shown in the figure. Please use 3.7V standard 18650 battery . Incorrect installation will cause electrical short circuit and equipment damage.

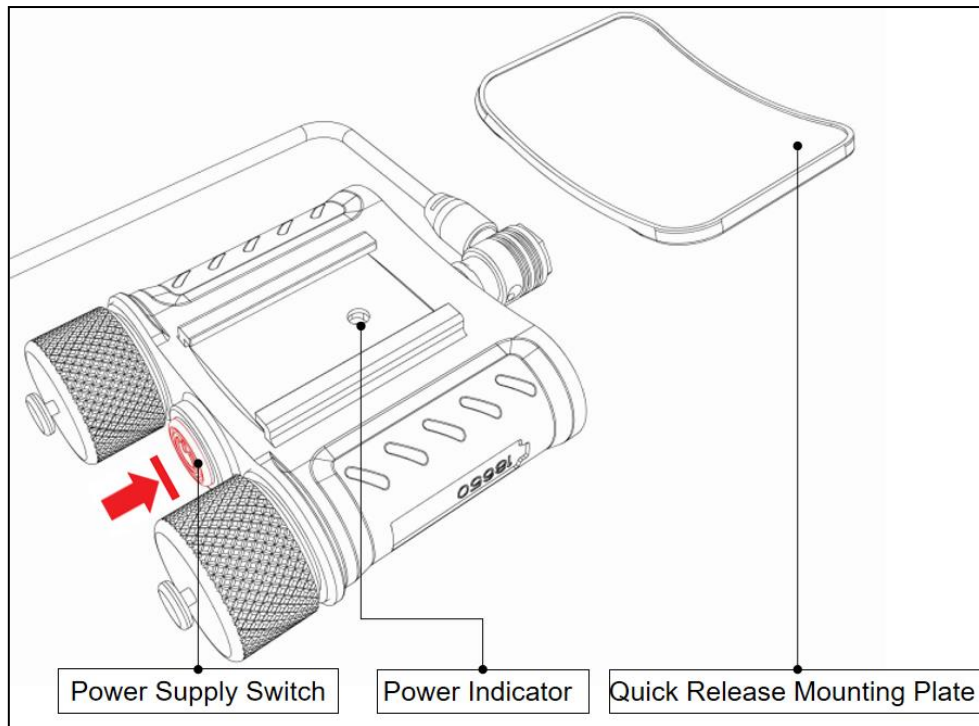



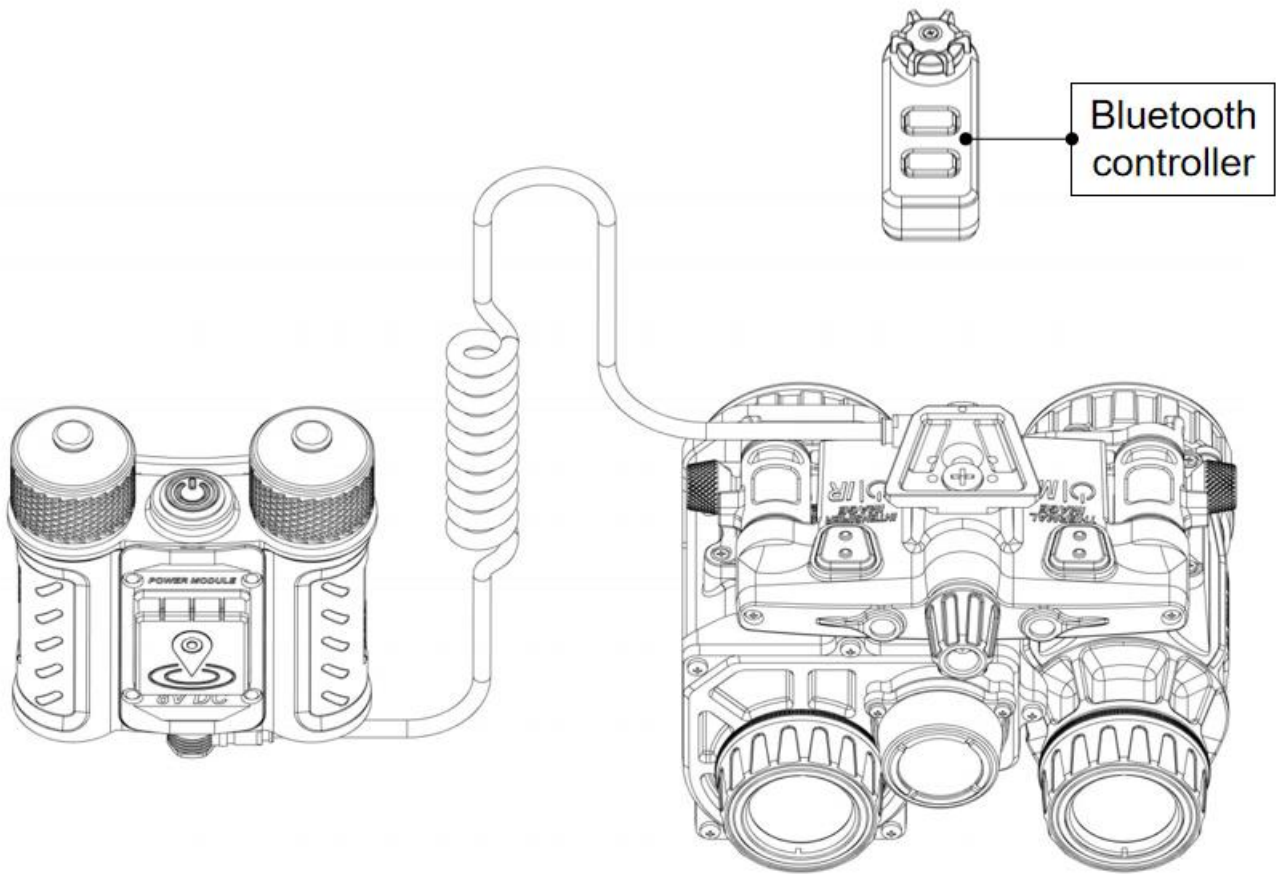

Turn on or off the power of the battery box as shown in the figure (long press). When the battery compartment is powered on, it displays the power (green, blue and red prompts). When it is used, click to display the current power

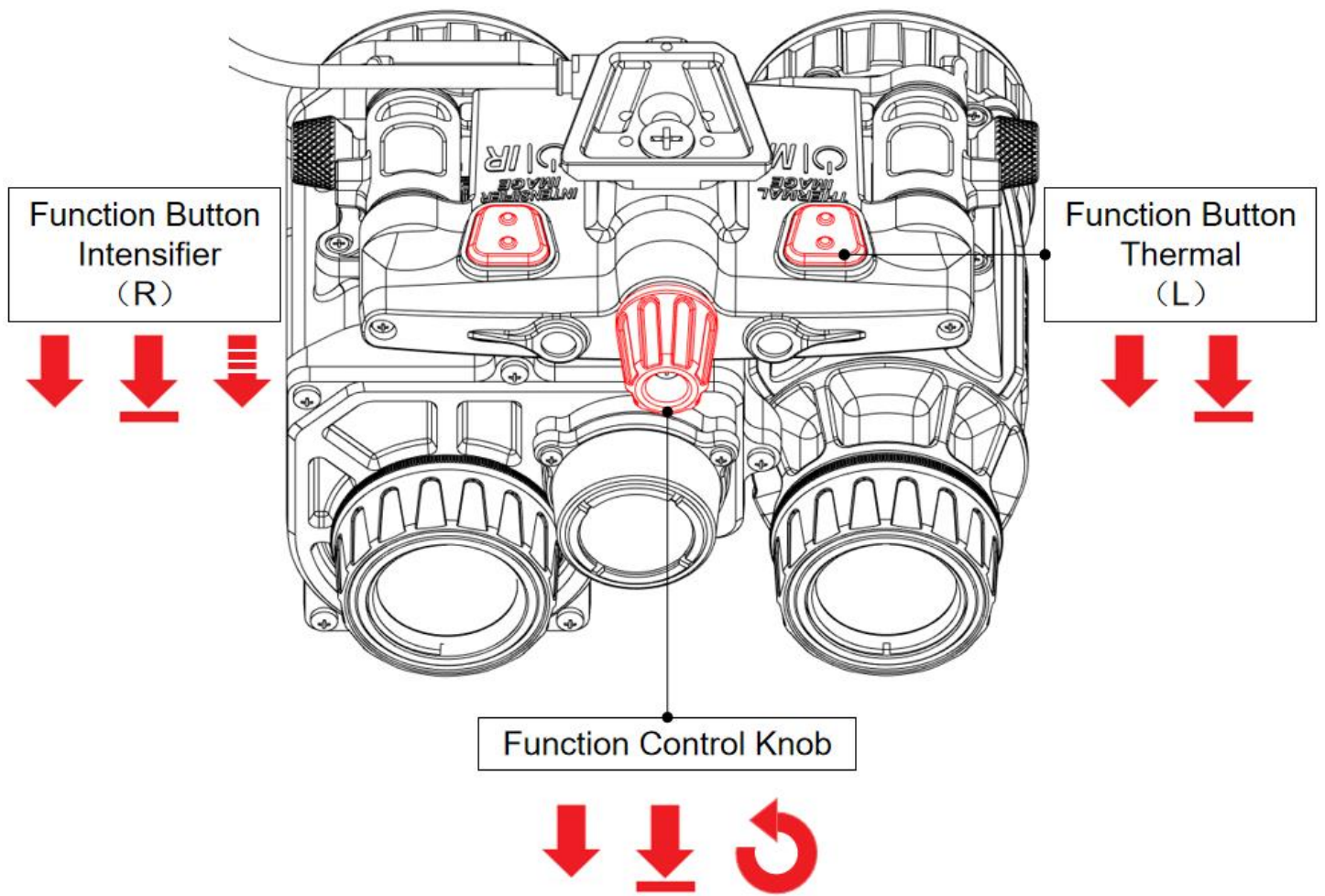

The external Bluetooth controller can control and adjust the host of the night vision instrument. Please set and adjust the remote controller through the "MENU-SENSOR-BT" . The Bluetooth remote controller has a sleep function. When the controller is not operated, it will automatically enter low-power sleep. Please click the middle button to wake up.



● Please control and adjust the whole machine as shown in the figure

position	Function control button (R)	Function Control Knob	Function control button (L)
 Long Press	Image Intensifier Switch	Enter menu	TI Switch
 Short Press	TI Refresh	Adjustment Switching	TI Mode Switching
 Three-Strikes	Fill light switch	/	/
 Rotate	/	Gear Adjustment	/

STATUS BAR

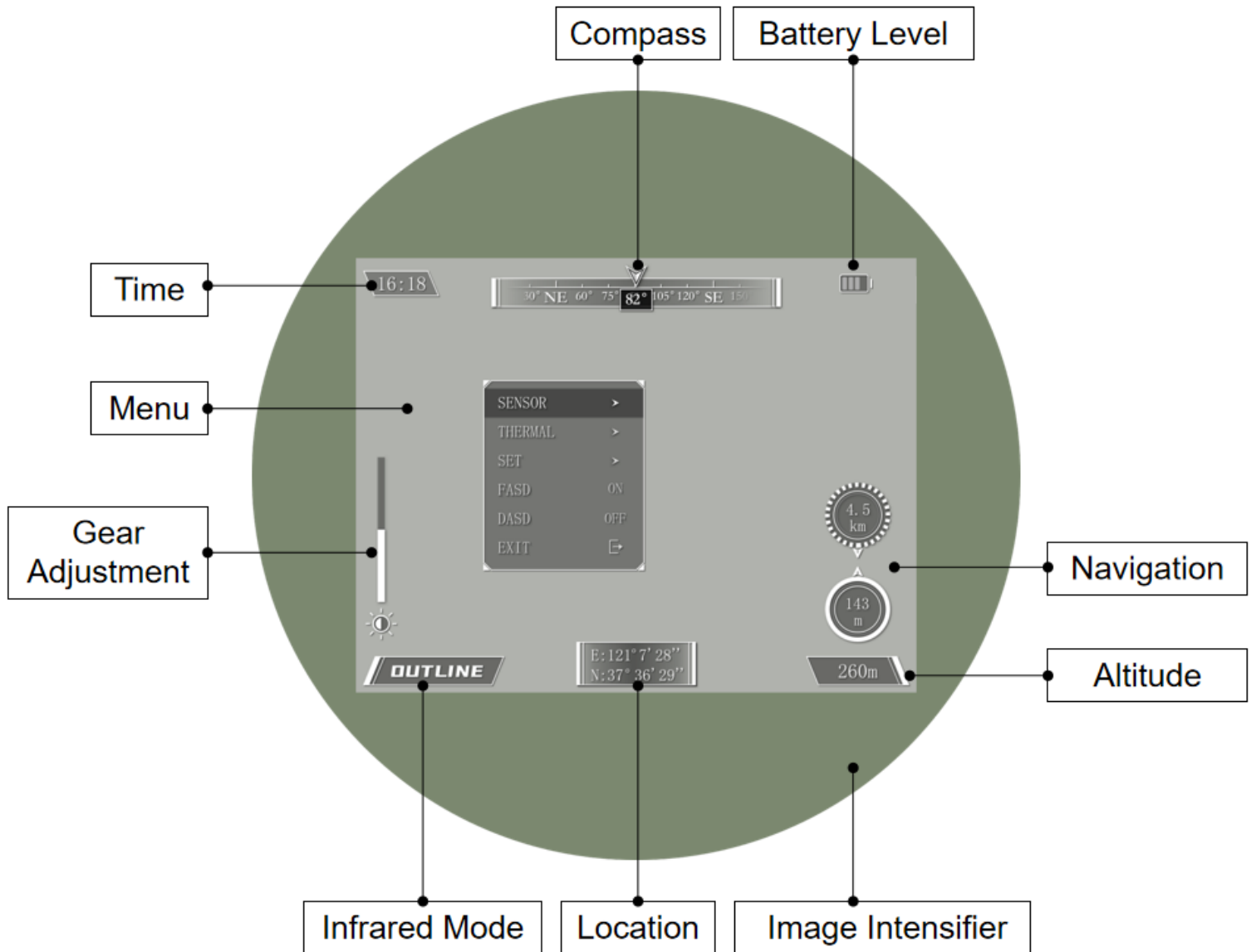

The equipment interface contains the above contents:

- **Image Intensifier** : Provide 40 ° FOV
- **Location** : Display the current positioning position (the positioning information will be automatically output when the machine is turned on. Please use it in an open place)

- **Infrared Mode**: Switch between Thermal mode and outline mode

Thermal mode: The target is displayed in full infrared, the threshold can be adjusted by 0%-100%, and the image will be switched from thermal image to highlight. (Please adjust the threshold according to the actual use environment to achieve the best use effect)

Outline mode: The target is displayed in outline, the threshold can be adjusted by 0%-100%, and the image will change the target details.(Please adjust the threshold according to the actual use environment to achieve the best use effect)

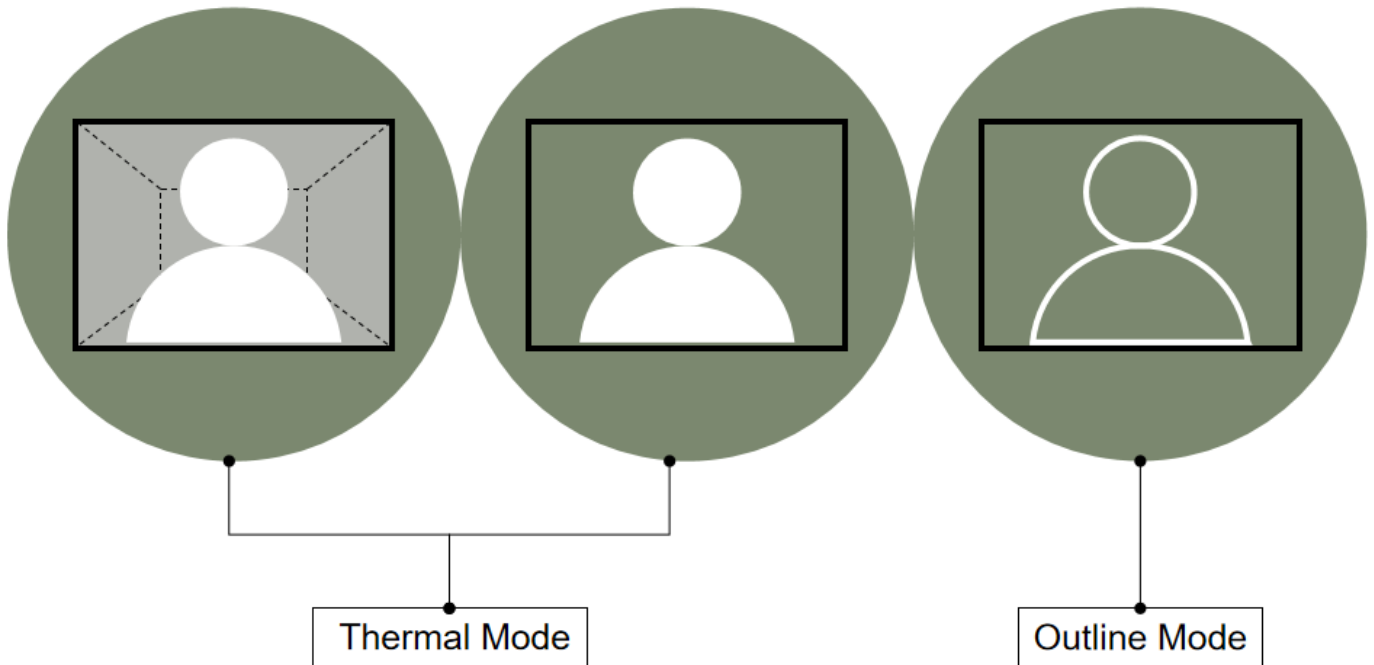

● **Gear Adjustment** : Adjust brightness,gain,frequency and threshold (0-100%)







Brightness:Adjust the thermal image brightness

Frequency:Frequency:When the “Twinkle” mode is started, Blinking speed can be adjusted through options

Threshold:Adjust the threshold function

Gain:Adjust the gain of NVG image tube

● Menu: Adjust menu functions

SENSOR	COMP	STD	Full status display of compass information
		NO.	Digital simplified display of compass information
		AC	With DASD and FASD kept off, complete compass calibration according to the operation tips
	NAV	W-X°X'X" N-X°X'X"	Set the first navigation point information and input the location information
		W-X°X'X" N-X°X'X"	Set the second navigation point information and input the location information
		OFF/ON	After the navigation switch is activated, the real-time target status will be displayed in the lower right corner of the main page When the positioning information is normal, the destination distance and direction will be updated in real time (distance accuracy $\pm 20m$)
		EXIT	
	BT	OFF/ON	The Bluetooth remote control switch is in position. After it is turned on, it can be operated by an external remote control
		SET	Bluetooth connection settings, you can set the Bluetooth connection after entering
	EXIT		
THERMAL	DORMANCY	OFF/ON	The infrared thermal image sleep function will hide the infrared image and retain the sensor information when it is started
	TWINKLE	OFF/ON	Infrared image twinkle function, supporting frequency adjustment
	BRIGHT	OFF/ON	Infrared bright color display to further enhance the target
	EXIT		
SET	OLED	5	Screen backlight brightness, suitable for different environments
	CAL		It is used for the coincidence calibration function of infrared and low light level, and can be used for translation calibration and saving
	INFO		Display product status and batch number
	UTC	0	Adjust the time according to the local time zone
	RESET		
	EXIT		
FASD	OFF/ON		The power-off function switch for up turning and side turning can automatically realize the power-off function of image tube and thermal image after the product is turned up.
DASD	OFF/ON		The external strong light protection switch turns off the power supply function of the image tube when the intensity is higher than a certain value.
EXIT			

- **Time** : Display current time(Output current information through positioning function)
- **Compass**: Display current orientation
- **Battery Level**: Display current power
- **Navigation**: Display navigation information

It supports dual target navigation indication (8 directional navigation and maximum 999km distance display), and can set target points and start functions through navigation.

- **Altitude**: Display current altitude(Output current information through positioning function)

INSTALLATION AND DEBUGGING OF IMAGE INTENSIFIER

Bridge Frame

Disassembly

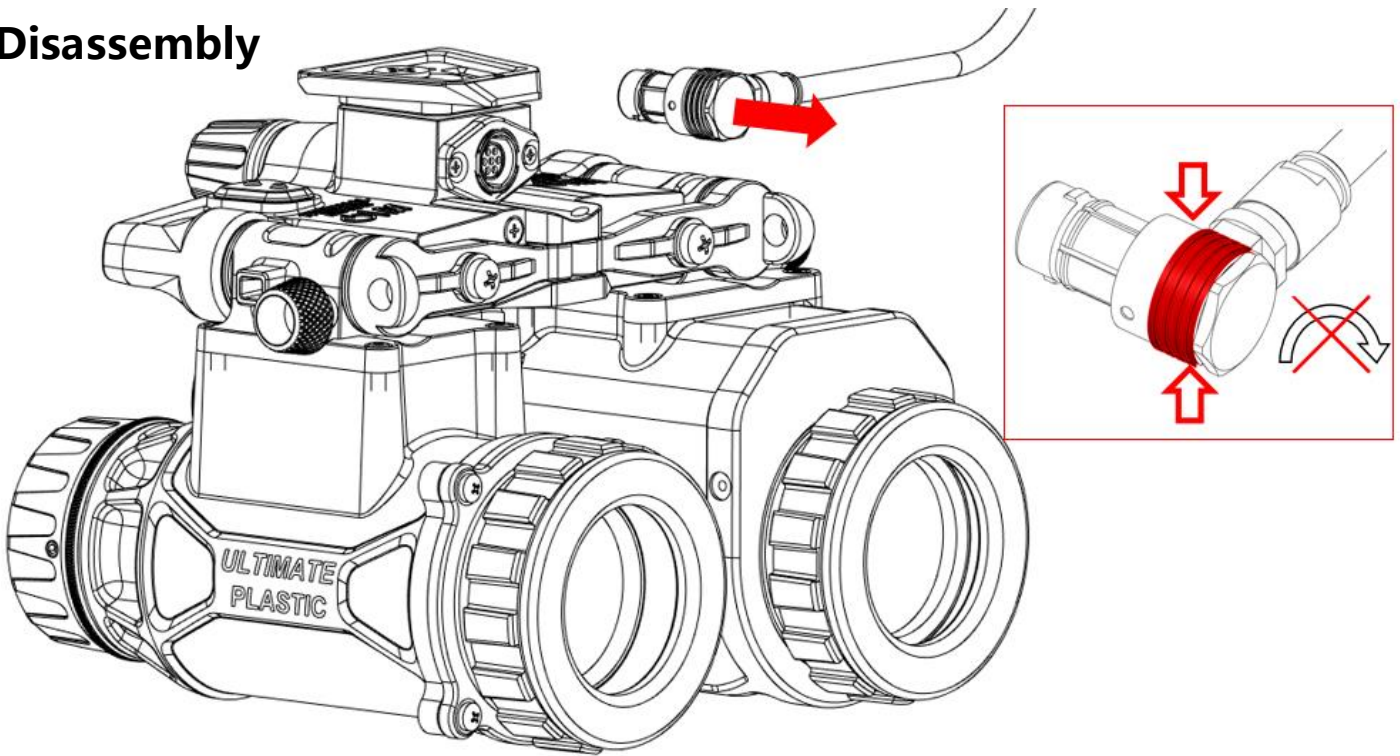

Please press and hold the cable head to remove the connecting cable(The red position is the lock ring). Do not use the knob connector, otherwise the device will be damaged

Bridge Frame

Disassembly

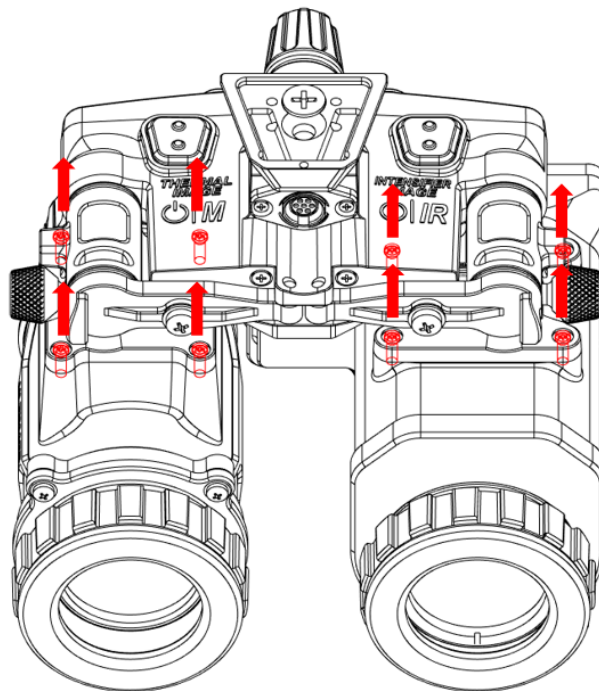

Please remove the left and right assembly screws (PM2-8 pcs.) as shown in the figure

Bridge Frame Disassembly

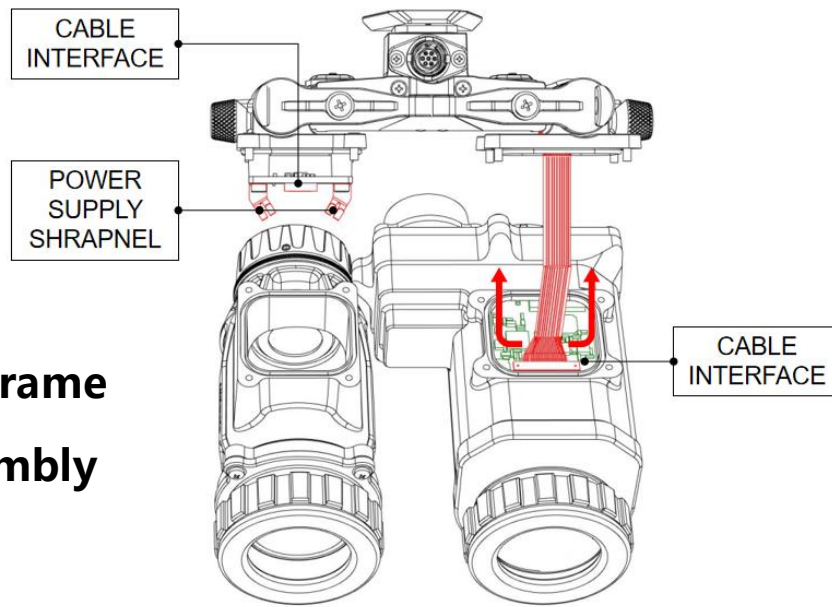

Please remove the PCB cable connector as shown in the figure (please carefully buckle the connector from both ends and do not pull the cable to avoid irreversible device damage)

Image Intensifier Cable Definition

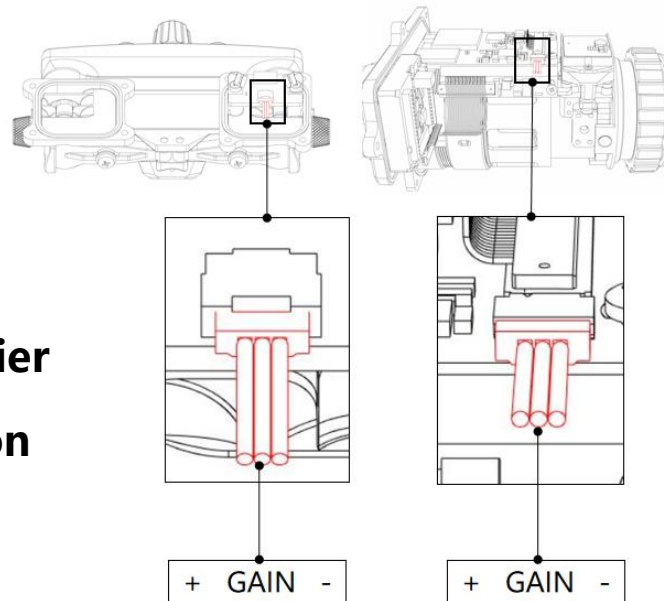

Support contact type, 2-wire and 3-wire image tubes

Please use 3-wire Image Intensifier for installation and adaptation.

White cable (Left) :Power in 3V

Black cable (Middle) :Gain 0-3V

Black cable (right) :Power GND

Left assembly

Disassembly

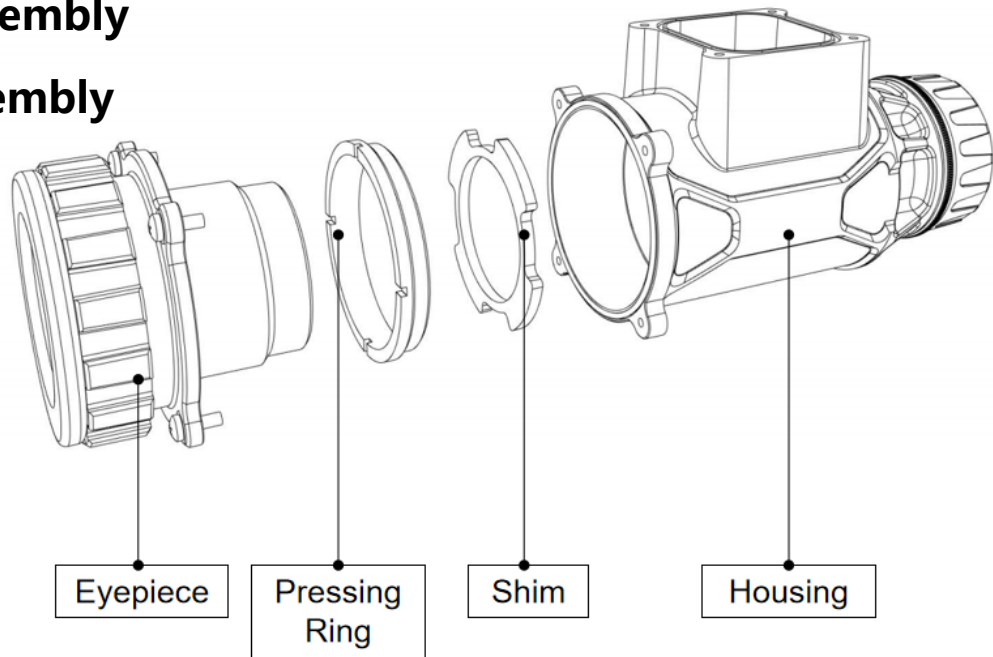

Please disassemble the left eye module as shown in the figure, and remove the eyepiece, pressing ring and shim in turn.

- **After installing the mx10160 Image Intensifier with the contact upward, restore the installation devices in turn and end the installation of the left component .**

Right assembly

Disassembly

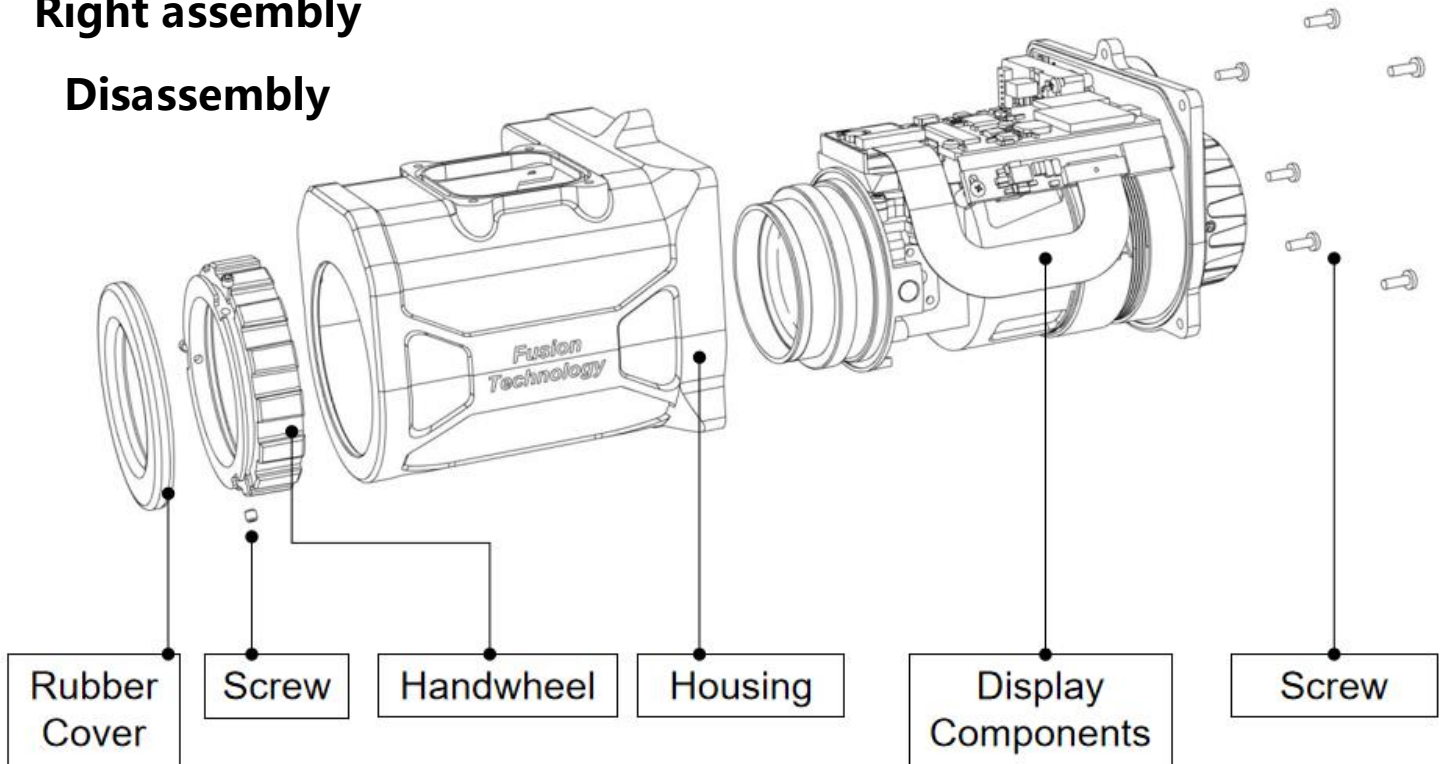

Please disassemble the right eye module as shown in the figure:

- Remove the eyepiece rubber cover
- Remove the hand wheel screws (M2-3pcs.) Remove the hand wheel after
- Remove the six screws from the front panel
- Remove the components slowly (please pay attention to the internal cables to avoid damage)

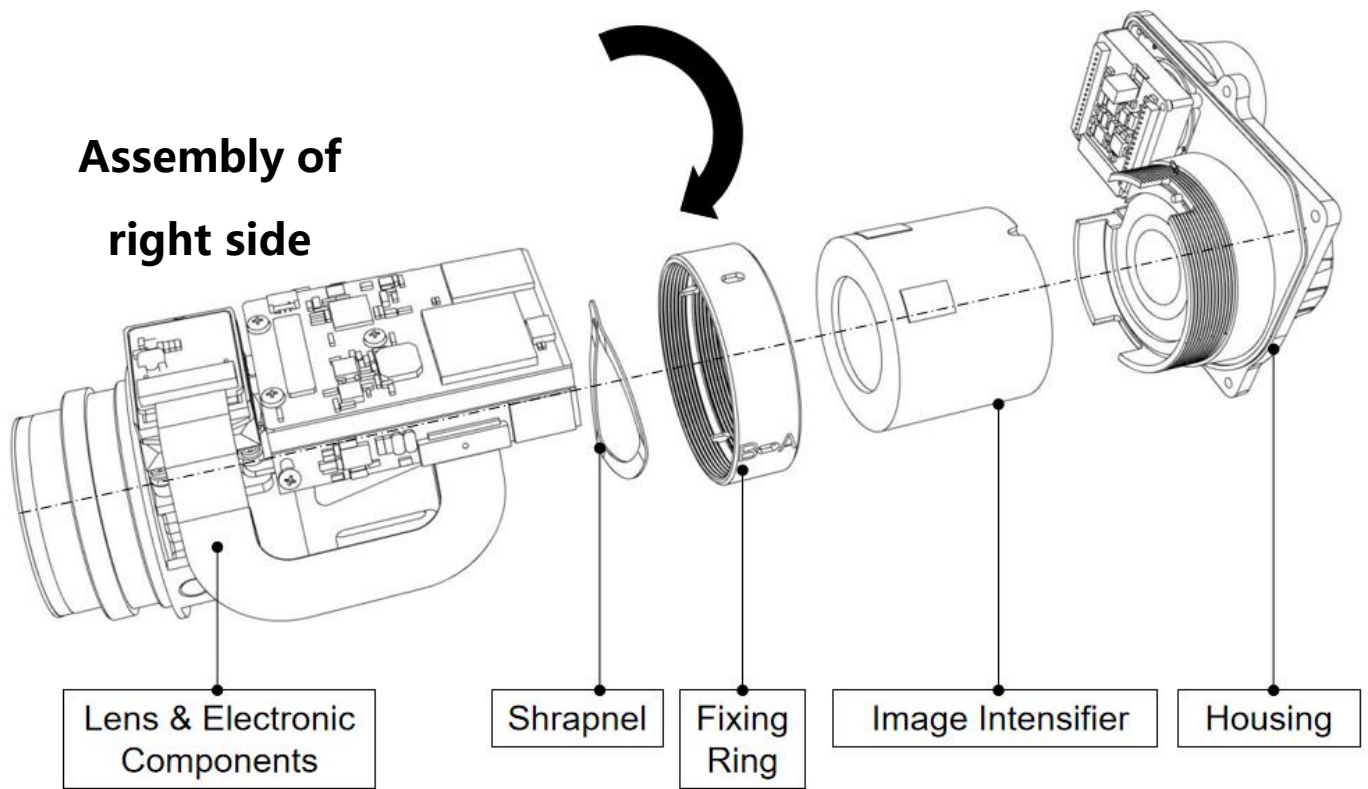

Perform the following operations as shown in the figure:

- Loosen fixing ring counterclockwise
- Install the image intensifier into housing (the contact piece faces the PCB) and install it in place in a directional manner
- Install shrapnel into "lens&electronic components"
- Put fixing ring "A" towards housing, and screw it in for 1/3 turn
- At the same time, pick up the front-end housing and rear-end integrated components, install the positioning structures at both ends, and rotate the fitting ring clockwise until it is installed in place
- Please observe whether the image intensifier is installed in place through the internal gap

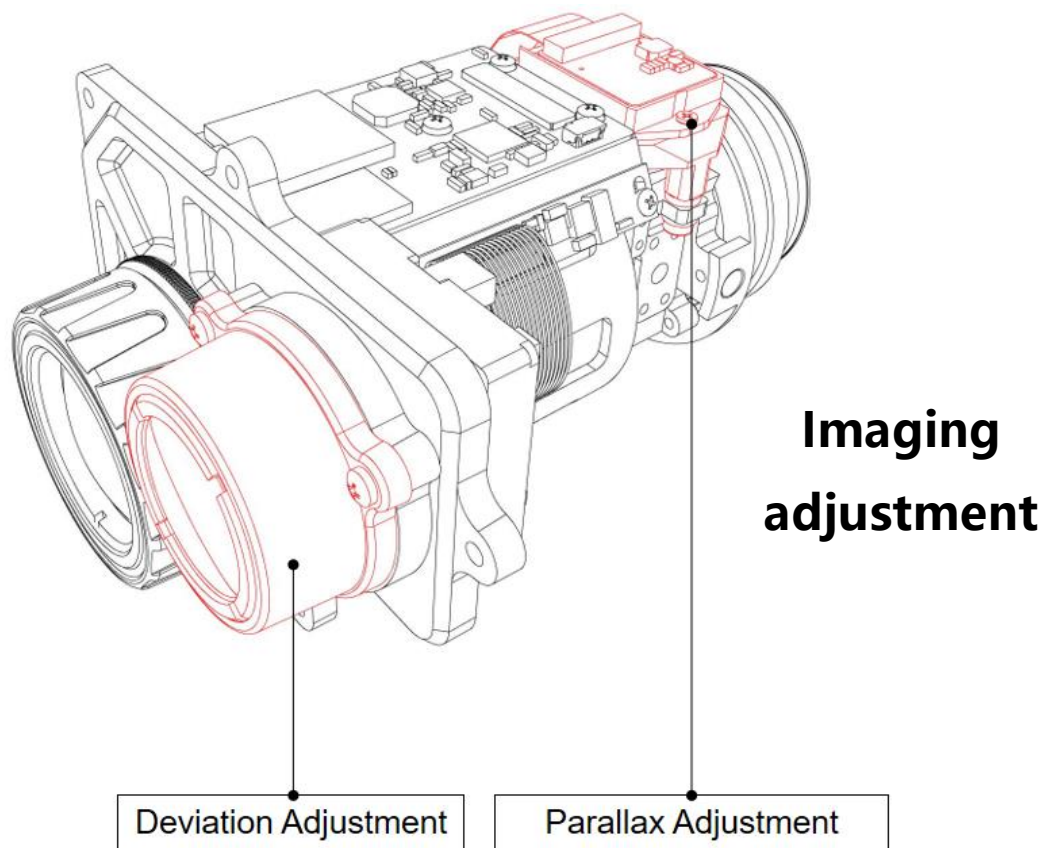

As shown in the figure, the two components are important components for imaging commissioning, Please select a target 35 meters away to complete the adjustment.

- Thermal image lens achieves image deviation adjustment by moving the lens horizontally. When the eyepiece is observed, the thermal image and the image intensifier image should remain coincident. The deviation adjustment effect of the image will affect the viewing effect of the right eye & both eyes, which is very important !
- The OLED display assembly realizes image Parallax Adjustment by moving the gasket up and down, so that the OLED imaging Focal plane coincides with the image intensifier imaging Focal plane. The parallax adjustment effect of the image will affect the viewing effect of both eyes, which is very important!

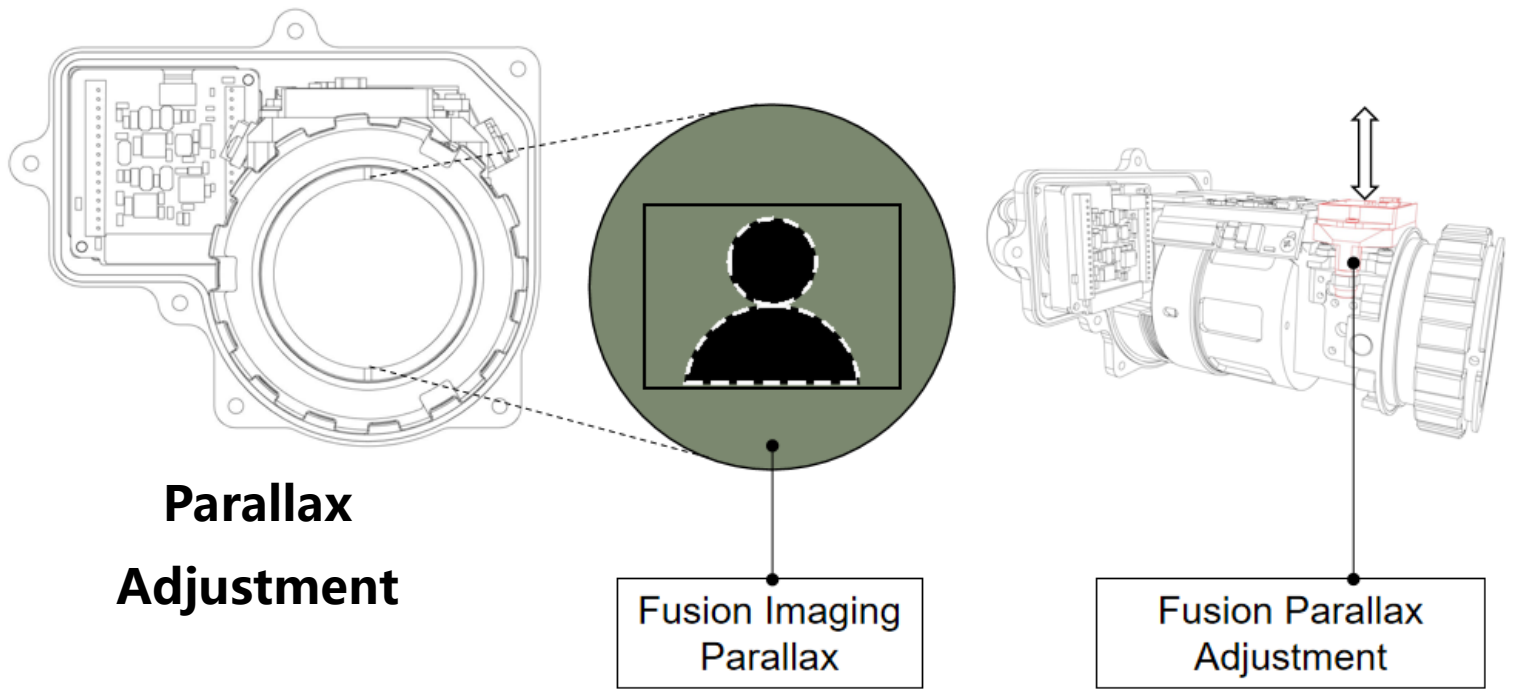

- If there is deviation in the imaging focal plane of the thermal image and image intensifier after installation (phenomena: 1. When shaking the product left and right, the thermal image and the low light level image have deviation and dislocation of the imaging plane; 2. When the thermal image or low light level image is clear and inconsistent), please manually adjust the two imaging planes to the same clear state by adjusting the height of the OLED bracket gasket.
- When there is no deviation in the left and right observation, the parallax adjustment is completed
- The effect of parallax adjustment will affect the effect of binocular stereo imaging

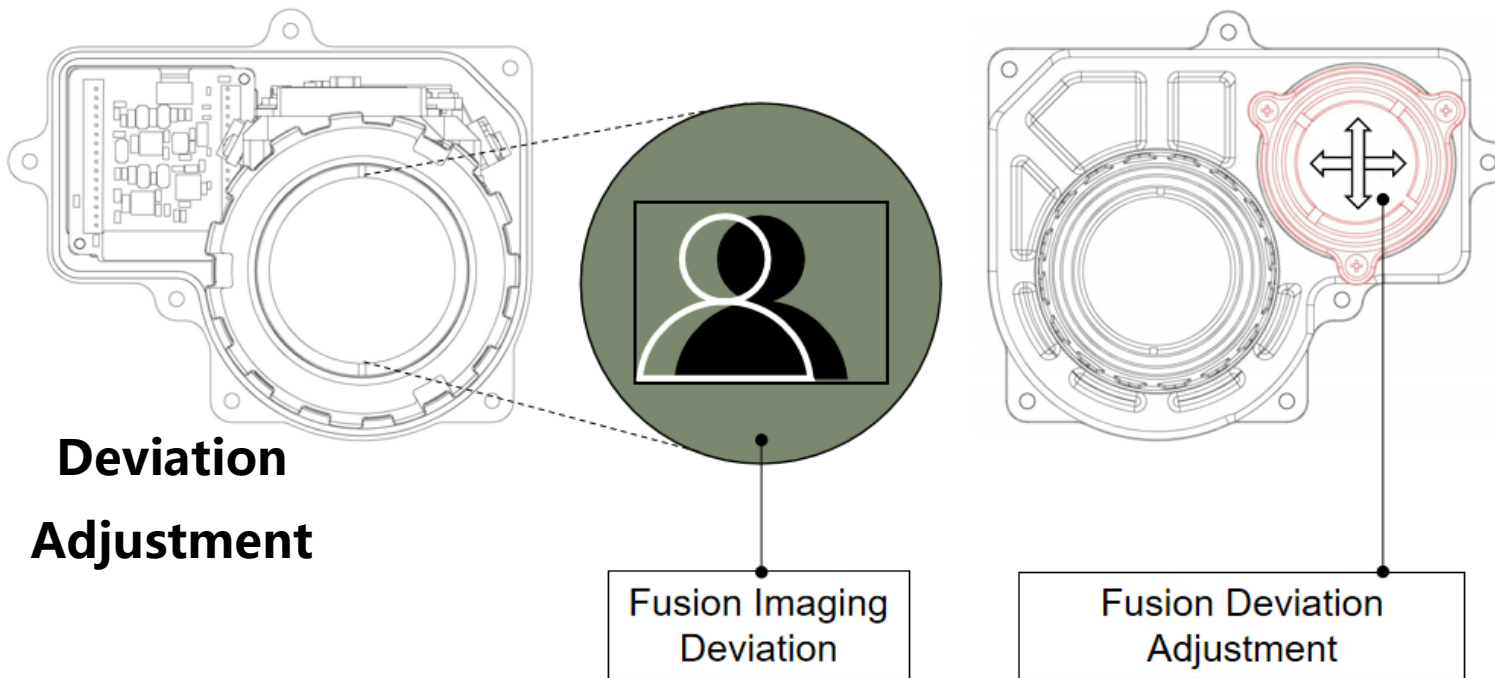

- If there is deviation between Thermal Image and Image Intensifier after installation, Please loosen the flange screw (M1.6-3pcs) and move the infrared lens flange to adjust the deviation, or fine tune the calibration through the MENU -SET-Deviation

Infrared lens adjustment calibration: **rough calibration**

Menu deviation calibration: **trim calibration**

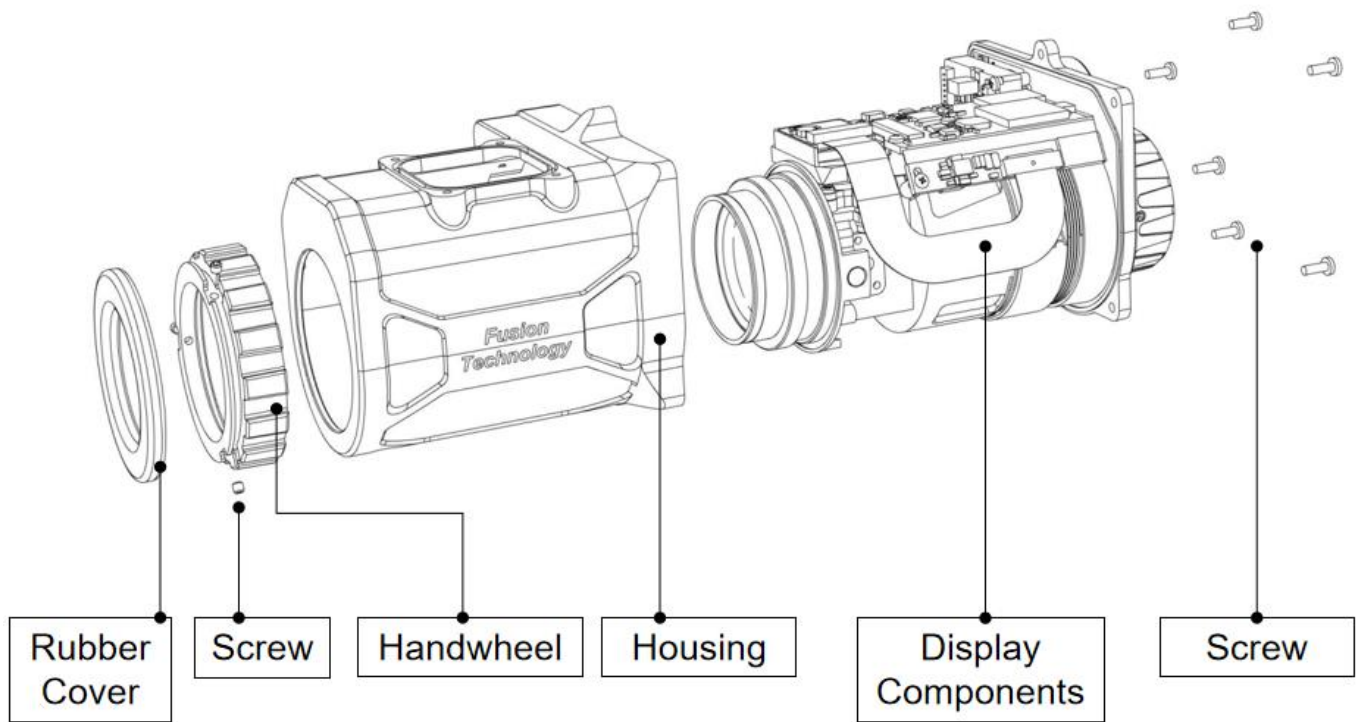

After completing the parallax and aberration adjustment, assemble and restore the components as shown in the figure.(replace the waterproof rubber pad if necessary to achieve sealing effect)

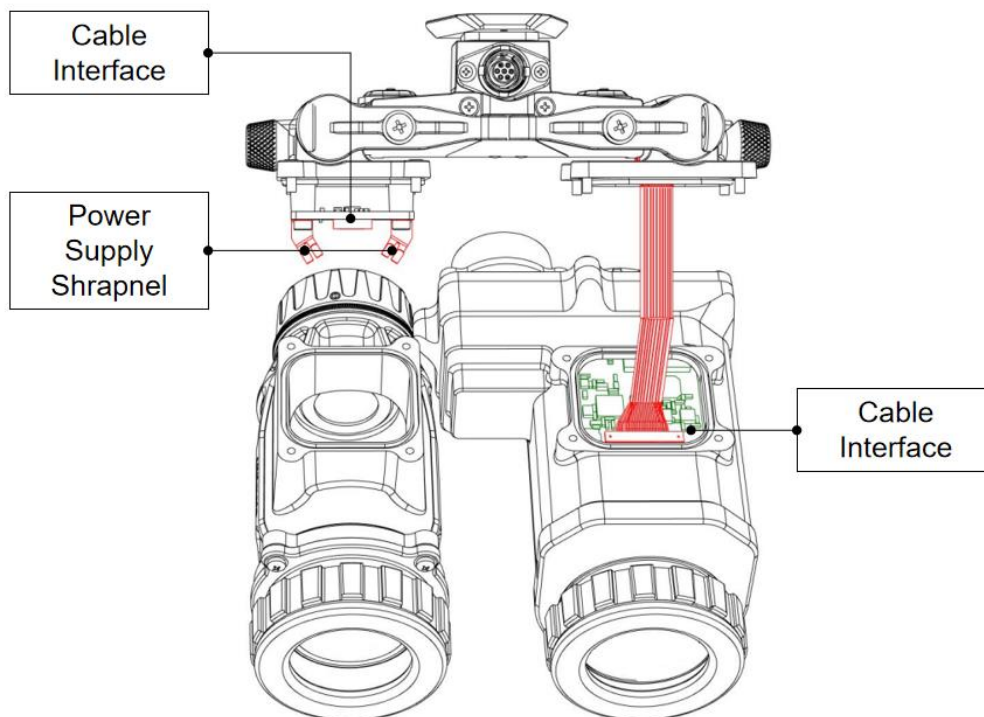

Complete bridge assembly and restoration.

Install the cable, open the battery compartment, check the function of the product, and carry out the next commissioning after confirming that the function is OK.

Biaxial calibration

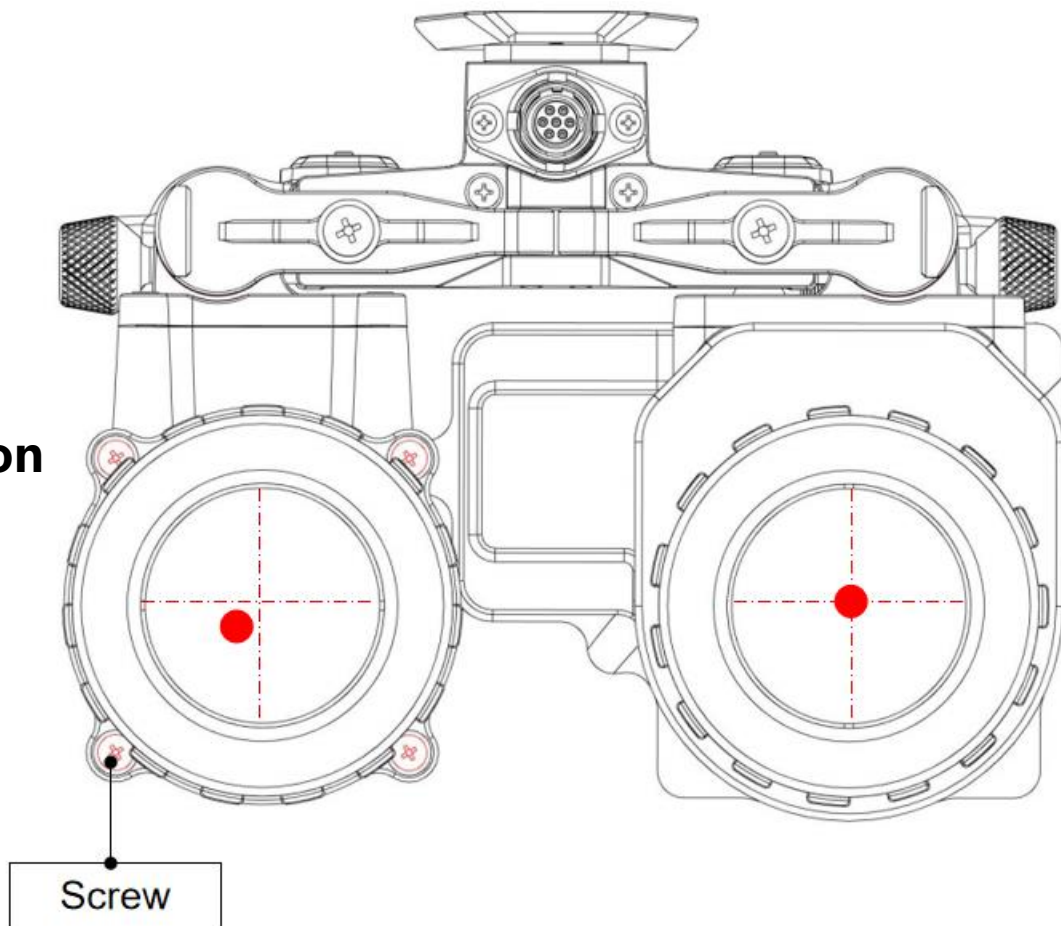

If the whole machine has difficulty in combining images after completing the adjustment of aberration and parallax, and it still cannot be solved after adjusting the visibility of the left and right eyepieces, please loosen the screws of the left eyepiece, and then translate the left eyepiece to achieve the optical axis calibration.

STORAGE AND TRANSPORTATION

- Before storing it, clean obligatory the device (if on its surface there are moisture, dust or traces of dirt) !
- Make sure that there are no traces of moisture, and the battery compartment is empty !
- It is also possible for a short periods of time device to be stored in a suitable soft pack,bag or cartridge box !
- The premises in which the device is kept for long term have to be dry, enclosed, unheatedand ventilated !
- During the storage should not be allowed exposure to aggressive environments, temperatures !
- below -50°C and above $+60^{\circ}\text{C}$, relative humidity greater than 80%, and prolonged periods of direct sunlight !
- Before each transportation, the product should be neatly packed in its original packaging !
- (transport bag) and all other items and accessories should be carefully and steadily placed in the bag. After that the bag should be steadily placed in the transport suitcase !

TECHNICAL DATA SHEET OF J-FB SERIES

Optical Specifications
Magnification: 1 ×
Infrared Focal Length: 16mm
Focal Length Range: 25cm ~ +∞
Image Intensifier FOV: 40°
Infrared FOV: 25.9° × 20.9°
Eye Relief: 25mm
Diopter: +2/-4
Performance Specifications
Image Intensifier :Gen 2 (Gen 3 optional)
Infrared Thermal Imaging: 640×512-12μm
Display Mode: thermal, outline
Induction Information Display: Support
Up-turning Shutdown: Support
IPD adjust: Support
Positioning navigation: Support
Binocular Goggles Information
Dimensions:107×115×85mm
Weight: 570g (goggles)/320g (battery+cables)
Battery Life: 8H (infrared fusion), 80H (Image Intensifier only)
Power Supply Type: External battery
Bluetooth Control: Support
Interface Type: L4G24

EXCEPTIONS AND HANDLING

The following table lists the common faults of J-FB during use, and checks and takes corrective measures in the order indicated.

If there are unlisted faults or corrective actions cannot eliminate abnormal problems, please go to a higher level of maintenance.

SN	Abnormal site	Test or inspection method	Corrective actions
1	Battery compartment battery cover cannot be properly installed or opened	<p>Check whether the installation direction of the battery is correct.</p> <p>Check for debris or debris around the battery cover.</p> <p>Check the battery cover for damage, wear or deformation.</p>	<p>Reinstall the 18650 battery (length 65 ± 0.5).</p> <p>Clean the threads of the battery cover and the battery compartment.</p> <p>Go to high level maintenance.</p>
2	Abnormal startup	<p>Check whether the battery is installed, whether the battery direction is correct, and whether the power is sufficient.</p> <p>Check whether the battery compartment power supply switch is on.</p>	<p>Replace the battery with a new one and install the battery correctly according to the instructions.</p> <p>Turn on the main power supply of the battery compartment and confirm that the power supply interface is installed normally.</p>
3	Low light level image cannot be displayed	<p>Confirm whether the low light level is used under the completely dark condition.</p> <p>Confirm whether the low light level objective lens cover is opened.</p>	<p>Open or cover the object light when using the micro lens under the condition of no light. Please open the fill light and mirror cover.</p> <p>Turn on the main power supply of the battery compartment.</p>

		<p>Confirm whether to turn on the main power switch of the battery compartment.</p> <p>Try adjusting the low light level.</p>	<p>Dim the dim light.</p>
4	<p>Infrared image cannot be displayed</p>	<p>Confirm whether the infrared objective lens cover is open.</p> <p>Confirm whether the battery compartment switch is on.</p> <p>Try adjusting the infrared brightness.</p> <p>Check whether there is any object blocking the infrared lens.</p>	<p>Open or close as required</p> <p>Turn on the main power supply of the battery compartment. Objective lens cover.</p> <p>Adjust the infrared brightness.</p> <p>Remove obstructions.</p>