

FCC Test Report (PART 95 Subpart I)

Report No.: RFBHSI-WTW-P21080074

FCC ID: 2AYGR-3040

Test Model: RC120 (EPC v2)

Received Date: Jul. 09, 2018

Test Date: Jul. 19 ~ Aug. 31, 2018 (For MedRadio channel access requirements test items)

Aug. 23 ~ Sep. 03, 2021 (Except for MedRadio channel access requirements test items)

Issued Date: Mar. 29, 2022

Applicant: Saluda Medical Pty Ltd

Address: Ground Floor, 407 Pacific Highway Artarmon, NSW, 2064, Australia

Issued By: Bureau Veritas Consumer Products Services (H.K.) Ltd., Taoyuan Branch
Lin Kou Laboratories

Lab Address: No. 47-2, 14th Ling, Chia Pau Vil., Lin Kou Dist., New Taipei City, Taiwan

Test Location: No.19, Hwa Ya 2nd Rd., Wen Hwa Vil., Kwei Shan Dist., Taoyuan City
33383, Taiwan

**FCC Registration /
Designation Number:** 788550 / TW0003



This report is for your exclusive use. Any copying or replication of this report to or for any other person or entity, or use of our name or trademark, is permitted only with our prior written permission. This report sets forth our findings solely with respect to the test samples identified herein. The results set forth in this report are not indicative or representative of the quality or characteristics of the lot from which a test sample was taken or any similar or identical product unless specifically and expressly noted. Our report includes all of the tests requested by you and the results thereof based upon the information that you provided to us. You have 60 days from date of issuance of this report to notify us of any material error or omission caused by our negligence, provided, however, that such notice shall be in writing and shall specifically address the issue you wish to raise. A failure to raise such issue within the prescribed time shall constitute your unqualified acceptance of the completeness of this report, the tests conducted and the correctness of the report contents. Unless specific mention, the uncertainty of measurement has been explicitly taken into account to declare the compliance or non-compliance to the specification.

Table of Contents

Release Control Record	4
1 Certificate of Conformity	5
2 Summary of Test Results	6
2.1 Test Instruments	7
2.2 Measurement Uncertainty	9
3 General Information	10
3.1 General Description of EUT	10
3.2 Configuration of System Under Test	11
3.3 Description of Test Modes	12
3.3.1 Test Mode Applicability and Tested Channel Detail	13
3.4 Description of Support Units	15
3.4.1 Configuration of System under Test	15
3.5 General Description of Applied Standards	15
4 Test Procedure and Results	16
4.1 Frequency error	16
4.1.1 Limits	16
4.1.2 Test Instruments	16
4.1.3 Test Procedures	16
4.1.4 Deviation from Test Standard	16
4.1.5 Test Setup	16
4.1.6 Test Results	17
4.2 Emission bandwidth & Emission Mask	18
4.2.1 Limits	18
4.2.2 Test Procedure	18
4.2.3 Deviation from Test Standard	18
4.2.4 Test Setup	19
4.2.5 Test Results	20
4.3 Occupied Bandwidth Measurement	22
4.3.1 Limits	22
4.3.2 Test Procedure	22
4.3.3 Deviation from Test Standard	22
4.3.4 Test Setup	22
4.3.5 Test Results	23
4.4 Transmitter Output Power (EIRP)	24
4.4.1 Limits	24
4.4.2 Test Instruments	24
4.4.3 Test Procedure	24
4.4.4 Deviation from Test Standard	24
4.4.5 Test Setup	25
4.4.6 Test Results	26
4.5 Transmitter Unwanted Emission	32
4.5.1 Limits	32
4.5.2 Test Instruments	32
4.5.3 Test Procedure	32
4.5.4 Deviation from Test Standard	33
4.5.5 Test Setup	34
4.5.6 Test Results	35
4.6 MedRadio Channel Access	47
4.6.1 LBT threshold power level	47
4.6.2 Monitoring system bandwidth	51
4.6.3 Monitoring system scan cycle time and minimum channel monitoring period	55
4.6.4 Channel access based on ambient levels relative to the calculated access LBT threshold level	61
4.6.5 Discontinuation of MICS session if a silent period greater than or equal to 5 seconds occurs	64

5	Photographs of the Test Configuration	65
	Appendix - Information of the Testing Laboratories	66



Release Control Record

Issue No.	Description	Date Issued
RFBHSI-WTW-P21080074	Original Release	Mar. 29, 2022

1 Certificate of Conformity

Product: Evoke Patient Controller
Brand: Saluda Medical
Test Model: RC120 (EPC v2)
Sample Status: Commercial sample
Applicant: Saluda Medical Pty Ltd
Test Date: Jul. 19 ~ Aug. 31, 2018 (For MedRadio channel access requirements test items)
Aug. 23 ~ Sep. 03, 2021 (Except for MedRadio channel access requirements test items)
Standards: FCC Part 95, Subpart I

The above equipment has been tested by **Bureau Veritas Consumer Products Services (H.K.) Ltd., Taoyuan Branch**, and found compliance with the requirement of the above standards. The test record, data evaluation & Equipment Under Test (EUT) configurations represented herein are true and accurate accounts of the measurements of the sample's Electromagnetic compatibility and Radio spectrum Matters (ERM) characteristics under the conditions specified in this report.

Prepared by : , **Date:** Mar. 29, 2022
Polly Chien / Specialist

Approved by : , **Date:** Mar. 29, 2022
Jeremy Lin / Project Engineer

2 Summary of Test Results

The EUT has been tested according to the following specifications:

FCC Part 95I & Part 2		
Clause	Test Descriptions	Result
FCC 95.2565 FCC 2.1055	Frequency Error	<input checked="" type="checkbox"/> Pass <input type="checkbox"/> Fail <input type="checkbox"/> N/A <input type="checkbox"/> N/P (Limited Program)
FCC 95.2573(a) & 2563(a) FCC 2.1047	Emission Bandwidth	<input checked="" type="checkbox"/> Pass <input type="checkbox"/> Fail <input type="checkbox"/> N/A <input type="checkbox"/> N/P (Limited Program)
FCC 95.2579(a)(c)	Emission Mask	<input checked="" type="checkbox"/> Pass <input type="checkbox"/> Fail <input type="checkbox"/> N/A <input type="checkbox"/> N/P (Limited Program)
FCC 2.1049	Occupied Bandwidth	<input checked="" type="checkbox"/> Pass <input type="checkbox"/> Fail <input type="checkbox"/> N/A <input type="checkbox"/> N/P (Limited Program)
FCC 95.2567(a)(1) FCC 2.1046	Transmitter Output Power	<input checked="" type="checkbox"/> Pass <input type="checkbox"/> Fail <input type="checkbox"/> N/A <input type="checkbox"/> N/P (Limited Program)
FCC 95.2579(a)(1)&(c)& (g) FCC 2.1053	Transmitter Unwanted Emission	<input checked="" type="checkbox"/> Pass <input type="checkbox"/> Fail <input type="checkbox"/> N/A <input type="checkbox"/> N/P (Limited Program)
FCC 95.2559	MedRadio channel access requirements	<input checked="" type="checkbox"/> Pass <input type="checkbox"/> Fail <input type="checkbox"/> N/A <input type="checkbox"/> N/P (Limited Program)
FCC 95.2559(a)(3)&(4)	LBT Threshold Power Levels	<input checked="" type="checkbox"/> Pass <input type="checkbox"/> Fail <input type="checkbox"/> N/A <input type="checkbox"/> N/P (Limited Program)
FCC 95.2559(a)(1)	Monitoring System Bandwidth	<input checked="" type="checkbox"/> Pass <input type="checkbox"/> Fail <input type="checkbox"/> N/A <input type="checkbox"/> N/P (Limited Program)
FCC 95.2559(a)(2)	Monitoring System Scan Cycle Time	<input checked="" type="checkbox"/> Pass <input type="checkbox"/> Fail <input type="checkbox"/> N/A <input type="checkbox"/> N/P (Limited Program)
FCC 95.2559(a)(6)	Minimum Channel Monitoring Period	<input checked="" type="checkbox"/> Pass <input type="checkbox"/> Fail <input type="checkbox"/> N/A <input type="checkbox"/> N/P (Limited Program)
FCC 95.2559(a)(5)	Channel Access	<input checked="" type="checkbox"/> Pass <input type="checkbox"/> Fail <input type="checkbox"/> N/A <input type="checkbox"/> N/P (Limited Program)
FCC 95.2559(a)(5) /95.2557(a)	Discontinuation of MICS Session	<input checked="" type="checkbox"/> Pass <input type="checkbox"/> Fail <input type="checkbox"/> N/A <input type="checkbox"/> N/P (Limited Program)

N/A: Not Applicable

N/P: Not Performed

Note: Determining compliance based on the results of the compliance measurement, not taking into account measurement instrumentation uncertainty.

2.1 Test Instruments

MedRadio channel access requirements (FCC95.2559) test items:

Description & Manufacturer	Model No.	Serial No.	Cal. Date	Cal. Due
Signal Generator R&S	SMB100A	177994	Feb. 26, 2018	Feb. 25, 2019
MXG Vector signal generator KEYSIGHT	N5182B	MY53052282	Dec. 28, 2017	Dec. 27, 2018
Spectrum Analyzer R&S	FSU43	101261	Jan. 11, 2018	Jan. 10, 2019
Signal Generator R&S	SMJ100A	101943	Nov. 15, 2017	Nov. 14, 2018
Function Generator HAMEG	HM8150	051220025	NA	NA

- Note: 1. The calibration interval of the above test instruments is 12 months and the calibrations are traceable to NML/ROC and NIST/USA.
 2. The test was performed in HwaYa Chamber 9.
 3. Tested date: Jul. 19 ~ Aug. 31, 2018

Except for MedRadio channel access requirements test items

Description & Manufacturer	Model No.	Serial No.	Cal. Date	Cal. Due
Test Receiver KEYSIGHT	N9038A	MY55420137	Apr. 09, 2021	Apr. 08, 2022
Spectrum Analyzer ROHDE & SCHWARZ	FSP40	100039	Jun. 10, 2021	Jun. 09, 2022
BILOG Antenna SCHWARZBECK	VULB9168	9168-160	Nov. 06, 2020	Nov. 05, 2021
HORN Antenna SCHWARZBECK	BBHA 9120 D	9120D-1169	Nov. 22, 2020	Nov. 21, 2021
HORN Antenna SCHWARZBECK	BBHA 9170	BBHA9170241	Nov. 22, 2020	Nov. 21, 2021
Loop Antenna TESEQ	HLA 6121	45745	Jul. 21, 2021	Jul. 20, 2022
Preamplifier Agilent (Below 1GHz)	8447D	2944A10638	Jun. 05, 2021	Jun. 04, 2022
Preamplifier Agilent (Above 1GHz)	8449B	3008A02367	Feb. 17, 2021	Feb. 16, 2022
RF signal cable HUBER+SUHNER&EMCI	SUCOFLEX 104 & EMC104-SM- SM8000	CABLE-CH9-02 (248780+171006)	Jan. 16, 2021	Jan. 15, 2022
RF signal cable HUBER+SUHNER	SUCOFLEX 104	CABLE-CH9- (250795/4)	Jan. 16, 2021	Jan. 15, 2022
RF signal cable Woken	8D-FB	Cable-CH9-01	Jun. 05, 2021	Jun. 04, 2022
Software BV ADT	ADT_Radiated_ V7.6.15.9.5	NA	NA	NA
Antenna Tower & Turn BV ADT	AT100	AT93021705	NA	NA
Turn Table BV ADT	TT100	TT93021705	NA	NA
Turn Table Controller BV ADT	SC100	SC93021705	NA	NA
Boresight Antenna Fixture	FBA-01	FBA-SIP01	NA	NA
STANDARD TEMPERATURE & HUMIDITY CHAMBER TERCHY	MHU-225AU	920842	Jun. 15, 2021	Jun. 14, 2022
DC power supply Keysight	U8002A	MY56330015	NA	NA
Digital Multimeter Fluke	87-III	70360742	Jun. 24, 2021	Jun. 23, 2022
Spectrum Analyzer ROHDE & SCHWARZ	FSU43	100115	Feb. 03, 2021	Feb. 02, 2022

Note: 1. The calibration interval of the above test instruments is 12 months and the calibrations are traceable to NML/ROC and NIST/USA.
2. The test was performed in HwaYa Chamber 9.
3. Tested date: Aug. 23 ~Sep. 03, 2021

2.2 Measurement Uncertainty

Where relevant, the following measurement uncertainty levels have been estimated for tests performed on the EUT:

This uncertainty represents an expanded uncertainty expressed at approximately the 95% confidence level using a coverage factor of $k=2$.

Parameter	Uncertainty
Radio Frequency	$\pm 1.13 \times 10^{-8}$
Adjacent channel power	± 0.31 dB
RF power, conducted	± 0.61 dB
Conducted emission of transmitter	± 1.34 dB
Conducted emission of receivers	± 1.25 dB
Radiated emission of transmitter, valid up to 4 GHz	± 2.29 dB
Radiated emission of receiver, valid up to 4 GHz	± 2.29 dB
Conducted monitoring test system	± 1.34 dB
Radiated monitoring test system	± 2.29 dB
Temperature	± 0.6 °C
Humidity	± 4 %

3 General Information

3.1 General Description of EUT

Product	Evoked Patient Controller
Brand	Saluda Medical
Test Model	RC120 (EPC v2) (refer to Note 1 in this Section and in Section 2 for more details)
Sample Status	Commercial sample
Nominal Voltage	3Vdc (battery)
Voltage Operation Range	Vnom= 3V Vmin= 2.7V Vmax= 3.3V
Temperature Operating Range	Tmin: <input type="checkbox"/> -20°C <input type="checkbox"/> 0°C <input checked="" type="checkbox"/> 5 °C Tnom: <input checked="" type="checkbox"/> 25°C Tmax: <input type="checkbox"/> +35°C <input type="checkbox"/> 55°C <input checked="" type="checkbox"/> 40°C
Type of Power Source	<input checked="" type="checkbox"/> Battery (Alkaline/Lithium-Ion/Lead acid/Other) <input type="checkbox"/> Internal power supply <input type="checkbox"/> External power supply (USB) <input type="checkbox"/> Car Charger
Duty Cycle	<input type="checkbox"/> Continuous duty <input type="checkbox"/> Intermittent duty <input checked="" type="checkbox"/> Continuous operation
Modulation Type	FSK
Modulation Technology	2FSK
Transfer Rate	200kbps
Operating Frequency	402~405MHz
Number of Channels	8
Spectrum Access	LBT/AFA
EIRP Power (Measured Max. Average)	-18.81dBm
Antenna Type	uSplat TM PCB mounted antenna type <input checked="" type="checkbox"/> Integral <input type="checkbox"/> External
Antenna Connector	NA
Antenna Gain	-8.7dBi, <input checked="" type="checkbox"/> Specified by manufacturer <input type="checkbox"/> Measured
Test Sequence / Test Software Used	EMC Test Software PN 102448, Rev. 1.00, EPC EMC Test Firmware PN 102450 Rev. 1.00
Accessory Device	NA
Cable Supplied	NA

Note:

1. The EUT detailed information is provided in the following table.

Brand	Model	S/N	Rev	Ref
Saluda Medical	RC120 (EPC v2)	189	2.00	P/N 101522

3.2 Configuration of System Under Test



Remote site

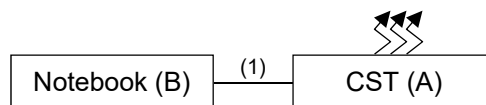

For LBT test

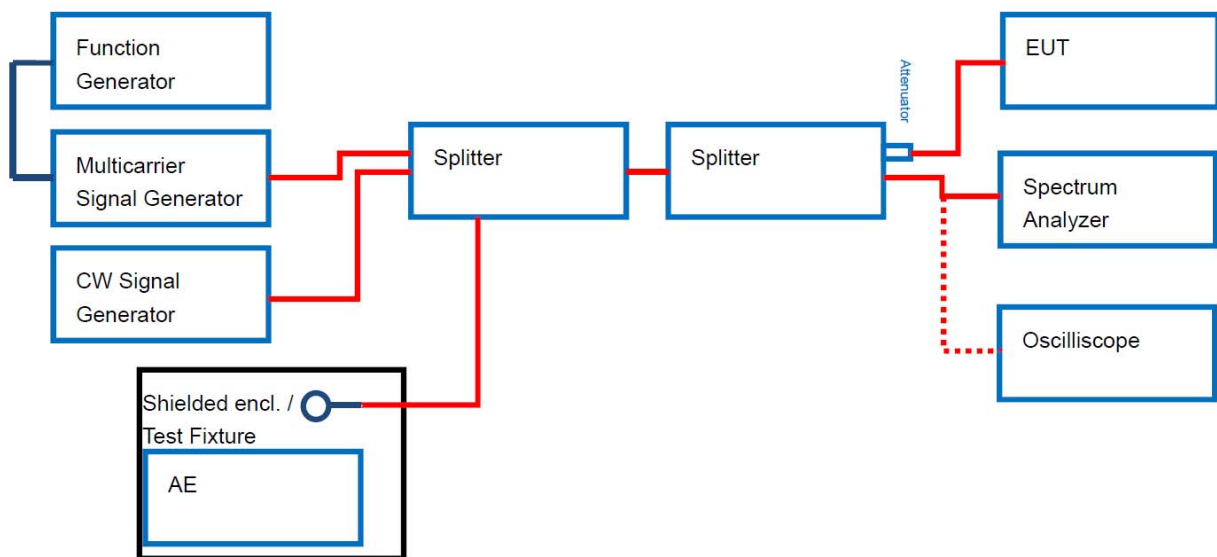

3.3 Description of Test Modes

8 channels are provided:

Channel	Frequency (MHz)	Channel	Frequency (MHz)
1(C-Low)	402.45	5 (C-Mid)	403.65
2	402.75	6	403.95
3	403.05	7	404.25
4	403.35	8(C-High)	404.55

The EUT is set in the following modes during tests:

- Permanent emission with modulation on a fixed channel at the highest power
- Permanent emission without modulation on a fixed channel at the highest power
- Search Loop

3.3.1 Test Mode Applicability and Tested Channel Detail

EUT configure mode	Applicable to								Description
	FE	EB	OB	EM	EIRP	TUE	SAP	RFE	
-	√	√	√	√	√	√	√	√	-

Where FE: Frequency Error
EB: Emission Bandwidth
OB: Occupied Bandwidth
EM: Emission Mask
TUE: Transmitter Unwanted Emission
SAP: Spectrum Access Protocol (MedRadio channel access requirements)
RFE: RF Exposure evaluation
EIRP: Transmitter Output Power (EIRP)

Note:

1. The antenna had been pre-tested on the positioned of each 3 axis. The worst case was found when positioned on Y-plane.
2. "-" means no effect.

Frequency Error:

- Pre-Scan has been conducted to determine the worst-case mode from all possible combinations between available modulations, data rates and antenna ports (if EUT with antenna diversity architecture).
- Following channel(s) was (were) selected for the final test as listed below.

EUT configure mode	Test condition	Available Channel	Tested Channel
-	<input checked="" type="checkbox"/> internal permanent antenna <input type="checkbox"/> temporary antenna connector <input type="checkbox"/> human torso simulator	1 - 8	1, 8

Emission Bandwidth:

- Pre-Scan has been conducted to determine the worst-case mode from all possible combinations between available modulations, data rates and antenna ports (if EUT with antenna diversity architecture).
- Following channel(s) was (were) selected for the final test as listed below.

EUT configure mode	Test condition	Available Channel	Tested Channel
-	<input checked="" type="checkbox"/> internal permanent antenna <input type="checkbox"/> temporary antenna connector <input type="checkbox"/> human torso simulator	1 - 8	1, 5, 8

Occupied Bandwidth:

- Pre-Scan has been conducted to determine the worst-case mode from all possible combinations between available modulations, data rates and antenna ports (if EUT with antenna diversity architecture).
- Following channel(s) was (were) selected for the final test as listed below.

EUT configure mode	Test condition	Available Channel	Tested Channel
-	<input checked="" type="checkbox"/> internal permanent antenna <input type="checkbox"/> temporary antenna connector <input type="checkbox"/> human torso simulator	1 - 8	1, 5, 8

Emission Mask:

- Pre-Scan has been conducted to determine the worst-case mode from all possible combinations between available modulations, data rates and antenna ports (if EUT with antenna diversity architecture).
- Following channel(s) was (were) selected for the final test as listed below.

EUT configure mode	Test condition	Available Channel	Tested Channel
-	<input checked="" type="checkbox"/> internal permanent antenna <input type="checkbox"/> temporary antenna connector <input type="checkbox"/> human torso simulator	1 - 8	1, 5, 8

Transmitter Output Power (EIRP):

- Pre-Scan has been conducted to determine the worst-case mode from all possible combinations between available modulations, data rates and antenna ports (if EUT with antenna diversity architecture).
- Following channel(s) was (were) selected for the final test as listed below.

EUT configure mode	Test condition	Available Channel	Tested Channel
-	<input checked="" type="checkbox"/> internal permanent antenna <input type="checkbox"/> temporary antenna connector <input type="checkbox"/> human torso simulator	1 - 8	1, 5, 8

Transmitter Unwanted Emission:

- Pre-Scan has been conducted to determine the worst-case mode from all possible combinations between available modulations, data rates and antenna ports (if EUT with antenna diversity architecture).
- Following channel(s) was (were) selected for the final test as listed below.

EUT configure mode	Test condition	Available Channel	Tested Channel
-	<input checked="" type="checkbox"/> internal permanent antenna <input type="checkbox"/> temporary antenna connector <input type="checkbox"/> human torso simulator	1 - 8	1, 5, 8

Spectrum Access Protocol (MedRadio channel access requirements):

- Pre-Scan has been conducted to determine the worst-case mode from all possible combinations between available modulations, data rates and antenna ports (if EUT with antenna diversity architecture).
- Following channel(s) was (were) selected for the final test as listed below.

EUT configure mode	Test condition	Available Channel	Tested Channel
-	<input checked="" type="checkbox"/> internal permanent antenna <input type="checkbox"/> temporary antenna connector <input type="checkbox"/> human torso simulator	1 - 8	5

Test Condition:

Applicable to	Environmental conditions	INPUT POWER	Tested by
FE	23 deg. C, 68% RH	3Vdc	Jisyong Wang
EB	23 deg. C, 68% RH	3Vdc	Jisyong Wang
OB	23 deg. C, 68% RH	3Vdc	Jisyong Wang
EM	23 deg. C, 68% RH	3Vdc	Jisyong Wang
EIRP	22 deg. C, 66% RH	3Vdc	Han Wu
TUE	22 deg. C, 66% RH	3Vdc	Han Wu
SAP	23 deg. C, 68% RH	3Vdc	Leo Tsai
RFE	23 deg. C, 68% RH	3Vdc	Han Wu

3.4 Description of Support Units

The EUT has been tested as an independent unit together with other necessary accessories or support units. The following support units or accessories were used to form a representative test configuration during the tests.

ID	Product	Brand	Model No.	Serial No.	FCC ID	Remarks
A.	Clinical System Transceiver	Saluda Medical	CST110, PN101448 Rev.1.00	171	NA	Provided by manufacturer
B.	Notebook	NA	Tablet Surface PC	015149160853	NA	Provided by manufacturer

Note:

1. All power cords of the above support units are non-shielded (1.8m).
2. Items A-B acted as communication partners to transfer data.

ID	Descriptions	Qty.	Length (m)	Shielding (Yes/No)	Cores (Qty.)	Remarks
1.	USB cable	1	1	Y	0	Attached to CST110

3.4.1 Configuration of System under Test

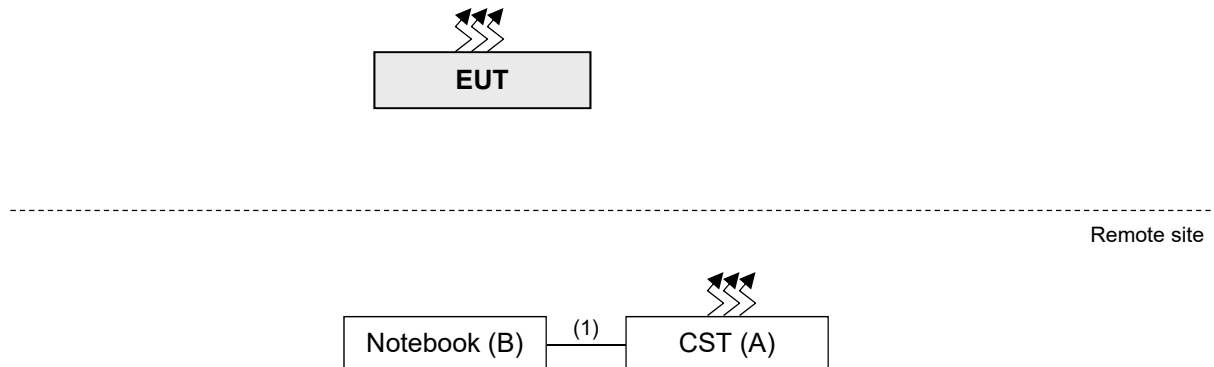

3.5 General Description of Applied Standards

The EUT is a RF Product. According to the specification of the EUT declared by the manufacturer, it must comply with the requirements of the following standards:

FCC 47 CFR Part 2

FCC 47 CFR Part 95 subpart I

Measurement Method:

ANSI C63.26:2015

All test items have been performed and recorded as per the above standard.

4 Test Procedure and Results

4.1 Frequency error

4.1.1 Limits

The frequency error for equipment operating in the 402 MHz to 405 MHz band shall not exceed ± 100 ppm under normal, extreme set of conditions.

4.1.2 Test Instruments

Refer to section 2.1 to get information of above instrument.

4.1.3 Test Procedures

- Device is placed at the oven room. The oven room could control the temperatures and humidity. Power warm up is at least 15 min and power applied should perform before recording frequency error.
- EUT is connected the external power supply to control the DC input power. The test voltage range is from minimum to maximum working voltage. Each step shall be record the frequency error rate.
- The temperature range step is 10 degrees in this test items. All temperature levels shall be hold the $\pm 0.5^\circ\text{C}$ during the measurement testing. The each temperature step shall be at least 0.5 hours, consider the EUT could be test under the stability condition.
- Measurement method refer to EN 301 839 section 5.3.1.

4.1.4 Deviation from Test Standard

No deviation

4.1.5 Test Setup

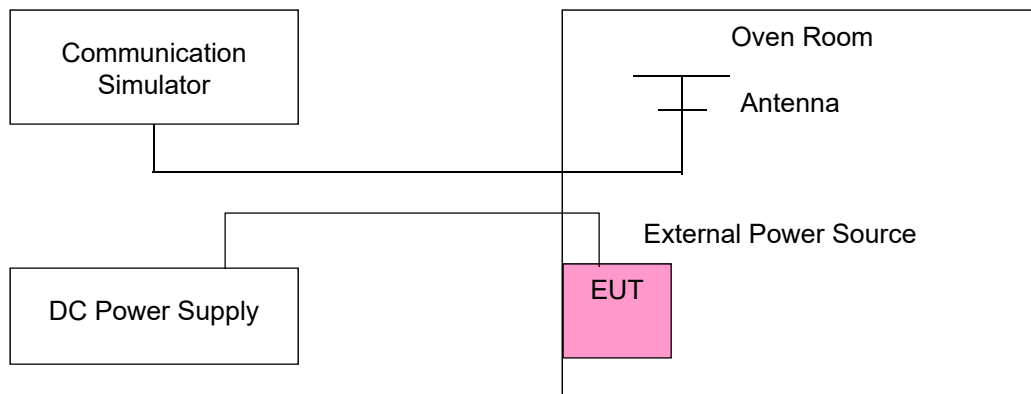

4.1.6 Test Results

Frequency Error vs. Voltage

Voltage (Vdc)	(CH1) 402.45 MHz		(CH8) 404.55 MHz	
	Frequency (MHz)	Frequency Error (ppm)	Frequency (MHz)	Frequency Error (ppm)
3.00	402.450800	1.988	404.551000	2.472
2.70	402.451200	2.982	404.551800	4.449
3.30	402.452000	4.970	404.552100	5.191

Note: The applicant defined the normal working voltage is from 2.70Vdc to 3.30Vdc.

Frequency Error vs. Temperature

Temp. (°C)	(CH1) 402.45 MHz		(CH8) 404.55 MHz	
	Frequency (MHz)	Frequency Error (ppm)	Frequency (MHz)	Frequency Error (ppm)
0	402.445800	-10.436	404.546800	-7.910
10	402.447400	-6.460	404.548800	-2.966
20	402.450800	1.988	404.551000	2.472
30	402.452400	5.963	404.553000	7.416
40	402.453500	8.697	404.552400	5.933
50	402.454600	11.430	404.553200	7.910
55	402.456100	15.157	404.554100	10.135

4.2 Emission bandwidth & Emission Mask

4.2.1 Limits

Emission bandwidth shall not exceed 300 kHz. If two or more devices that operate in a given MICS communications session operate in different portions of the 402 MHz to 405 MHz band, their combined emission bandwidths shall not exceed 300 kHz. This limits spectrum usage to a maximum of 300 kHz in any single MICS communications session. The 300 kHz limitation may be exceeded briefly due to intermittent transmissions that may occur when operating channel acquisitions or changes are required to maintain a communications session.

Emission Mask Attenuation requirements, 402-405 MHz. For MedRadio transmitter types designed to operate in the 402-405 MHz band, unwanted emissions must be attenuated below the maximum permitted transmitter output power by at least:

- (1) 20 dB, on any frequency within the 402-405 MHz band that is more than 150 kHz away from the center frequency of the MedRadio channel the transmission is intended to occupy;
- (2) 20 dB, on any frequency between 401.750 MHz and 402.000 MHz, and on any frequency between 405 MHz and 405.250 MHz.

4.2.2 Test Procedure

- a. The emission bandwidth was radiated measurement.
- b. EUT placed on the 0.8m height of Turn Table, rotated the table around 360 degrees to search the maximum radiation power and receiver antenna shall be rotated vertical and horizontal polarization and moved height from 1m to 4m to find the maximum polar radiated power.
- c. The bandwidth of the fundamental frequency was measured by spectrum analyzer with RBW = 3kHz and VBW = 10kHz. The 20dB bandwidth is defined as the total spectrum the power of which is higher than peak power minus 20dB(spectrum analyzer with resolution bandwidth in the range of 1% to 5% of the anticipated emission bandwidth, and a video bandwidth at least 3x the resolution bandwidth).

4.2.3 Deviation from Test Standard

No deviation.

4.2.4 Test Setup

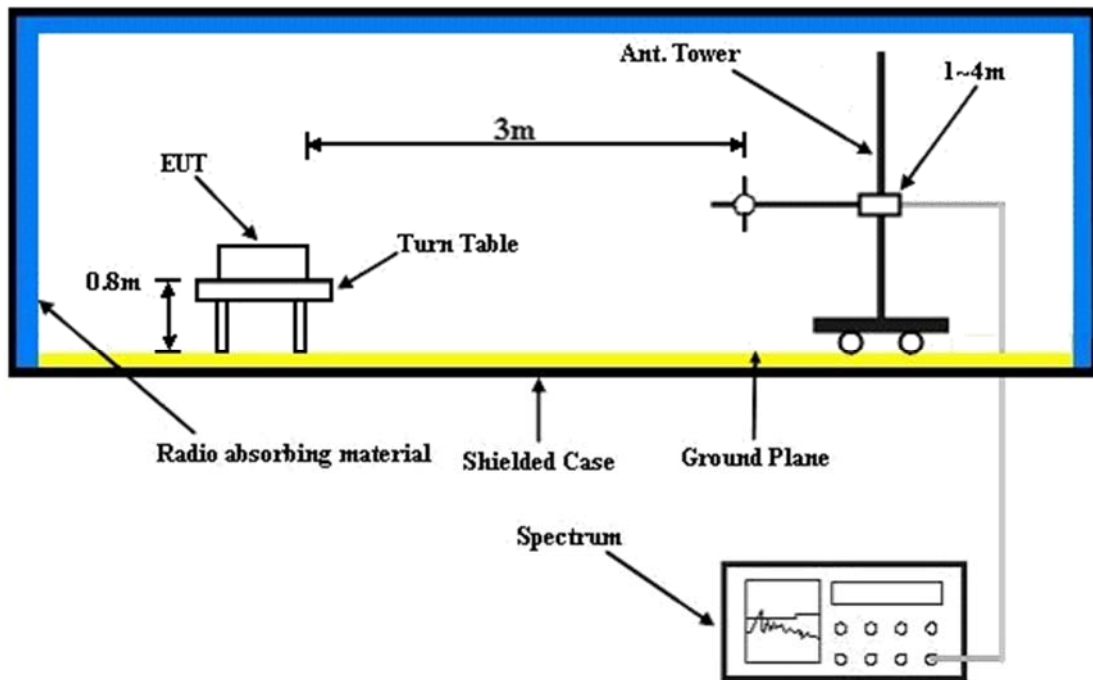

For the actual test configuration, please refer to the attached file (Test Setup Photo).

4.2.5 Test Results

Channel	Channel Frequency (MHz)	20dB down Bandwidth (MHz)	Measured Frequencies		Limit	Pass/Fail
			F _L (MHz)	F _H (MHz)		
1	402.45	0.251	402.321	402.572	FL > 402 MHz and FH < 405 MHz and 0.3 MHz	Pass
5	403.65	0.240	403.529	403.769		Pass
8	404.55	0.230	404.437	404.667		Pass

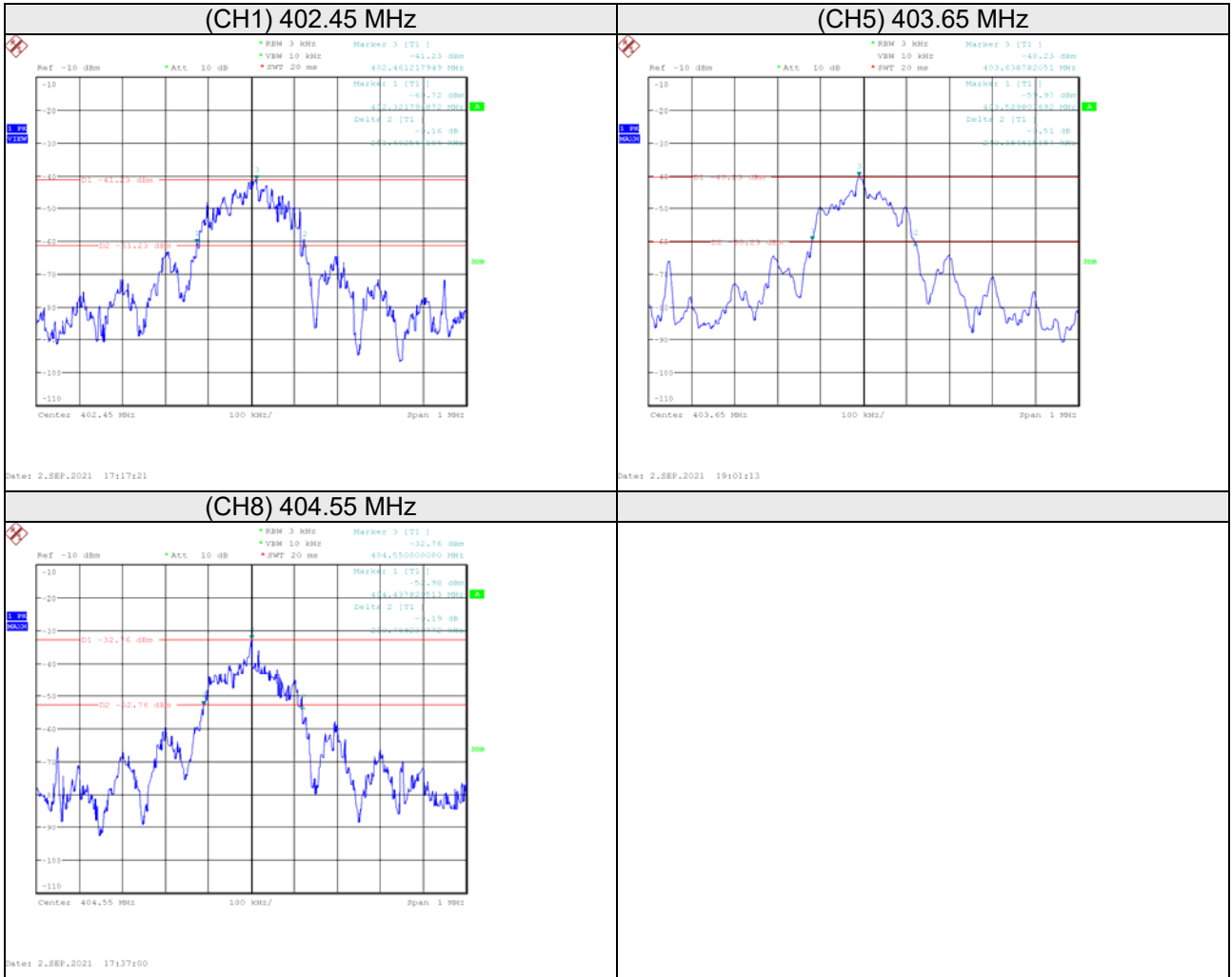

For emission Mask:

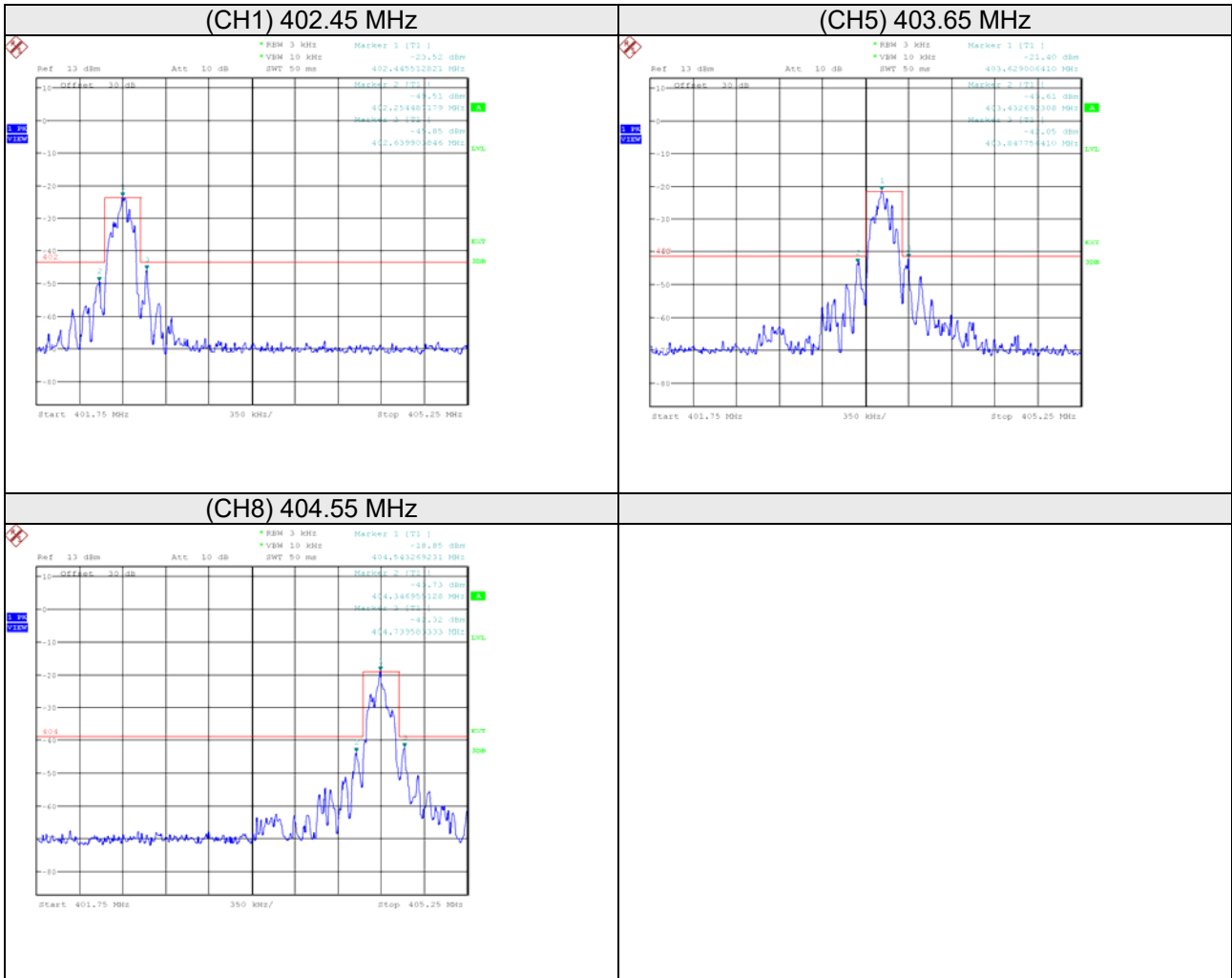

4.3 Occupied Bandwidth Measurement

4.3.1 Limits

No limit.

4.3.2 Test Procedure

- a. The emission bandwidth was radiated measurement.
- b. EUT placed on the 0.8m height of Turn Table, rotated the table around 360 degrees to search the maximum radiation power and receiver antenna shall be rotated vertical and horizontal polarization and moved height from 1m to 4m to find the maximum polar radiated power.
- c. The bandwidth of the fundamental frequency was measured by spectrum analyzer with resolution bandwidth in the range of 1% to 5% of the anticipated emission bandwidth, and a video bandwidth at least 3x the resolution bandwidth and set the detector to peak.

The transmitter output was connected to the spectrum analyzer through an attenuator. The bandwidth of the fundamental frequency was measured by spectrum analyzer with resolution bandwidth in the range of 1% to 5% of the anticipated emission bandwidth, and a video bandwidth at least 3x the resolution bandwidth and set the detector to peak. The width of a frequency band such that, below the lower and above the upper frequency limits, the mean powers emitted are each equal to a specified percentage 0.5 % of the total mean power of a given emission.

4.3.3 Deviation from Test Standard

No deviation.

4.3.4 Test Setup

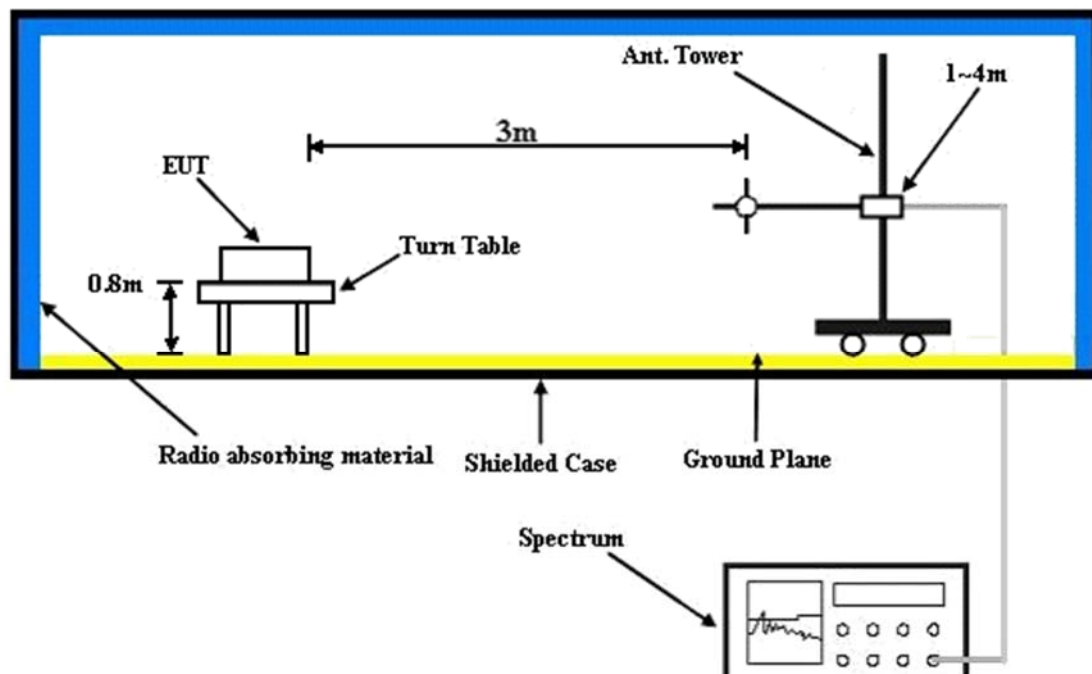

For the actual test configuration, please refer to the attached file (Test Setup Photo).

4.3.5 Test Results

Centre Frequencies f_c (kHz)			
Channel	1	5	8
Occupied Bandwidth (99% emission bandwidth) (kHz)	241.99	243.59	243.59

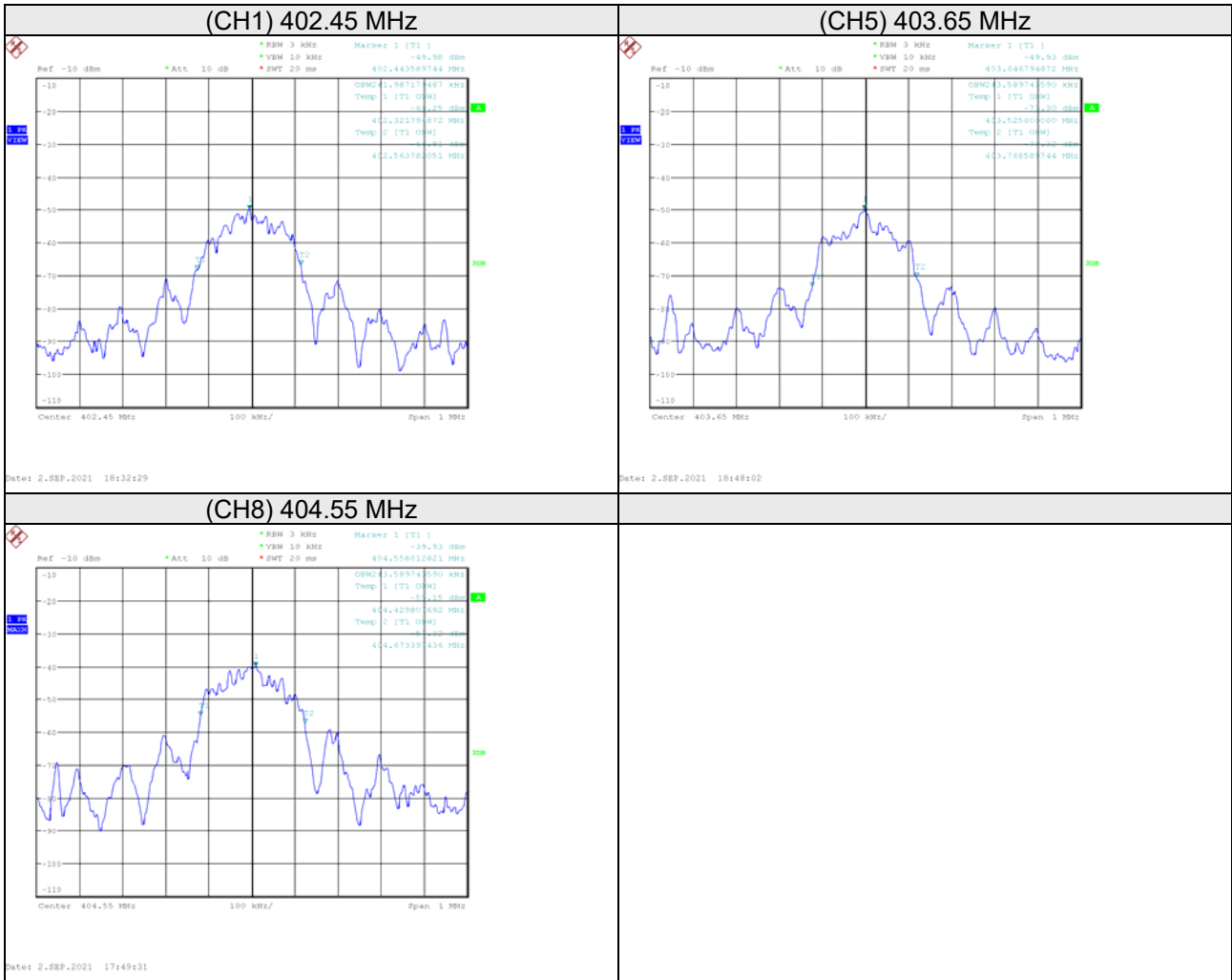

4.4 Transmitter Output Power (EIRP)

4.4.1 Limits

The M-EIRP within any 300 kHz bandwidth within the 402-405 MHz band must not exceed 25 microwatts..

4.4.2 Test Instruments

Refer to section 2.1 to get information of above instrument.

4.4.3 Test Procedure

- a. In the semi-anechoic chamber, EUT placed on the 0.8m(below or equal 1GHz) and/or 1.5m(above 1GHz) height of Turn Table, rotated the table around 360 degrees to search the maximum radiation power and receiver antenna shall be rotated vertical and horizontal polarization and moved height from 1m to 4m to find the maximum polar radiated power. The "Read Value" is the spectrum reading the maximum power value.
- b. The height of antenna is varied from one meter to four meters above the ground to determine the maximum value of the field strength. Both horizontal and vertical polarizations of the antenna are set to make the measurement.
- c. Perform a field strength measurement and record the worse read value, is the field strength value via a spectrum reading obtained corrected for antenna factor, cable loss and pre-amplifier factor and then mathematically convert the measured field strength level to EIRP/ERP level.
- d. Following C63.26 section 5.5 and 5.2.7.
 - $EIRP (dBm) = E (dB\mu V/m) + 20\log(D) - 104.8$; where D is the measurement distance (in the far field region) in m.
 - $ERP (dBm) = E (dB\mu V/m) + 20\log(D) - 104.8 - 2.15$; where D is the measurement distance (in the far field region) in m.

Note:

1. The resolution bandwidth and video bandwidth of test receiver/spectrum analyzer is 1MHz/3MHz.
2. The emission levels were against the limit of frequency range 9 kHz ~ 30 MHz:
The amplitude of spurious emissions attenuated more than 20 dB below the permissible value is not required to be report.

4.4.4 Deviation from Test Standard

No deviation.

4.4.5 Test Setup

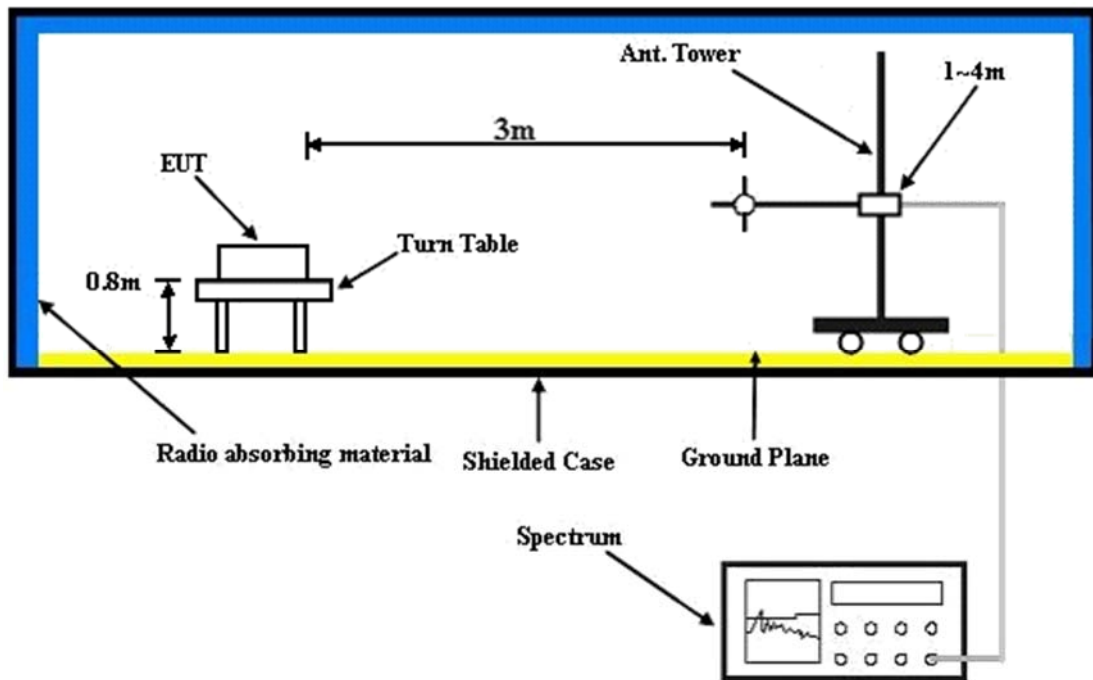

For the actual test configuration, please refer to the attached file (Test Setup Photo).

4.4.6 Test Results

Mode	TX channel 1 (402.45 MHz)	Frequency Range	Below 1000 MHz
Environmental Conditions	22deg. C, 66%RH	Input Power	120Vac, 60Hz
Tested By	Hans Wu		

Antenna Polarity & Test Distance : Horizontal at 3 m								
No	Frequency (MHz)	EIRP (dBm)	Limit (dBm)	Margin (dB)	Antenna Height (m)	Table Angle (Degree)	Raw Value (dBUV)	Correction Factor (dB/m)
1	402.45	-26.00	-16.02	-9.98	1.00 H	49	73.93	-99.93

Remarks:

1. $EIRP(dBm) = Raw\ Value(dBuV) + Correction\ Factor(dB/m)$
2. $Correction\ Factor(dB/m) = Antenna\ Factor(dB/m) + Cable\ Factor(dB) - Pre-Amplifier\ Factor(dB) + 20\log(D) - 104.8$
3. $Margin\ value = EIRP - Limit\ value$
4. The other EIRP levels were very low against the limit.

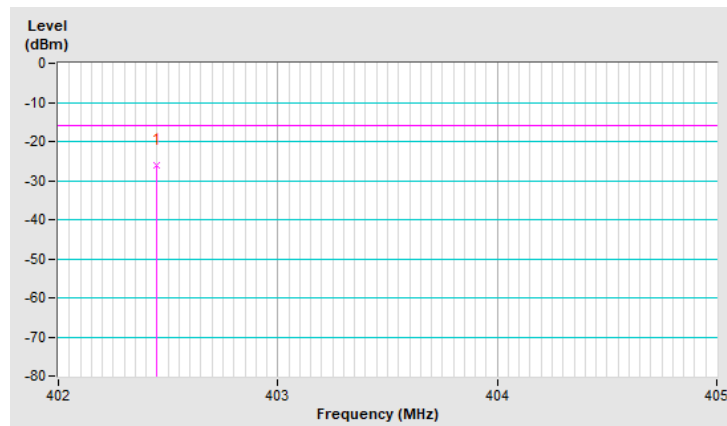

Mode	TX channel 1 (402.45 MHz)	Frequency Range	Below 1000 MHz
Environmental Conditions	22deg. C, 66%RH	Input Power	120Vac, 60Hz
Tested By	Hans Wu		

Antenna Polarity & Test Distance : Vertical at 3m								
No	Frequency (MHz)	EIRP (dBm)	Limit (dBm)	Margin (dB)	Antenna Height (m)	Table Angle (Degree)	Raw Value (dBUV)	Correction Factor (dB/m)
1	402.45	-32.82	-16.02	-16.80	1.10 V	147	67.11	-99.93

Remarks:

1. $EIRP(dBm) = Raw\ Value(dBuV) + Correction\ Factor(dB/m)$
2. $Correction\ Factor(dB/m) = Antenna\ Factor(dB/m) + Cable\ Factor(dB) - Pre-Amplifier\ Factor(dB) + 20\log(D) - 104.8$
3. $Margin\ value = EIRP - Limit\ value$
4. The other EIRP levels were very low against the limit.

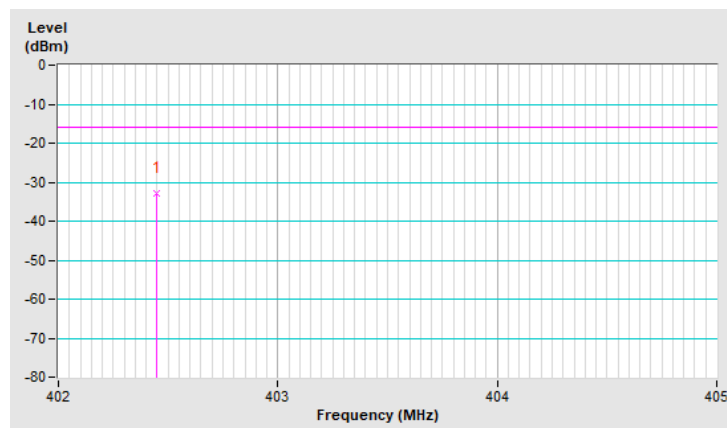

Mode	TX channel 5 (403.65 MHz)	Frequency Range	Below 1000 MHz
Environmental Conditions	22deg. C, 66%RH	Input Power	120Vac, 60Hz
Tested By	Hans Wu		

Antenna Polarity & Test Distance : Horizontal at 3 m								
No	Frequency (MHz)	EIRP (dBm)	Limit (dBm)	Margin (dB)	Antenna Height (m)	Table Angle (Degree)	Raw Value (dBuV)	Correction Factor (dB/m)
1	403.65	-21.40	-16.02	-5.38	1.00 H	49	78.51	-99.91

Remarks:

1. $EIRP(dBm) = Raw\ Value(dBuV) + Correction\ Factor(dB/m)$
2. $Correction\ Factor(dB/m) = Antenna\ Factor(dB/m) + Cable\ Factor(dB) - Pre-Amplifier\ Factor(dB) + 20\log(D) - 104.8$
3. $Margin\ value = EIRP - Limit\ value$
4. The other EIRP levels were very low against the limit.

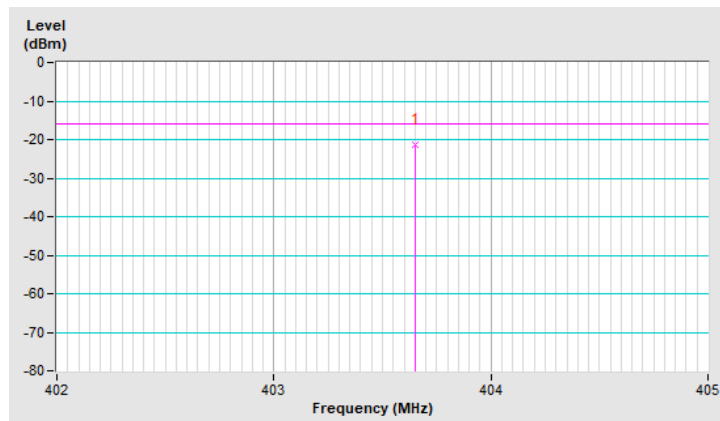

Mode	TX channel 5 (403.65 MHz)	Frequency Range	Below 1000 MHz
Environmental Conditions	22deg. C, 66%RH	Input Power	120Vac, 60Hz
Tested By	Hans Wu		

Antenna Polarity & Test Distance : Vertical at 3m

No	Frequency (MHz)	EIRP (dBm)	Limit (dBm)	Margin (dB)	Antenna Height (m)	Table Angle (Degree)	Raw Value (dBUV)	Correction Factor (dB/m)
1	403.65	-28.18	-16.02	-12.16	1.10 V	145	71.73	-99.91

Remarks:

1. $EIRP(dBm) = Raw\ Value(dBuV) + Correction\ Factor(dB/m)$
2. $Correction\ Factor(dB/m) = Antenna\ Factor(dB/m) + Cable\ Factor(dB) - Pre-Amplifier\ Factor(dB) + 20\log(D) - 104.8$
3. $Margin\ value = EIRP - Limit\ value$
4. The other EIRP levels were very low against the limit.

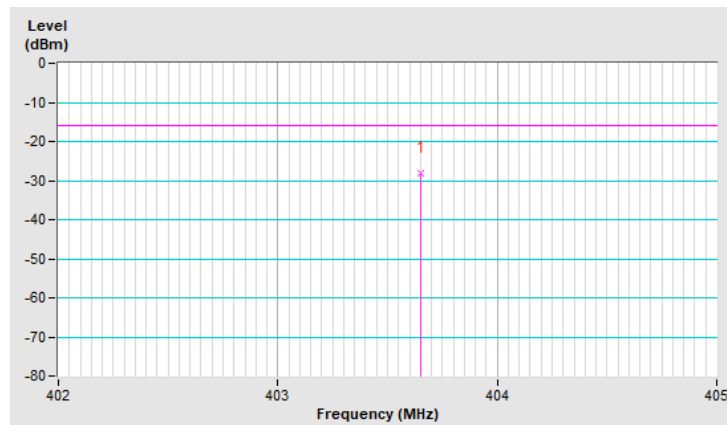

Mode	TX channel 8 (404.55 MHz)	Frequency Range	Below 1000 MHz
Environmental Conditions	22deg. C, 66%RH	Input Power	120Vac, 60Hz
Tested By	Hans Wu		

Antenna Polarity & Test Distance : Horizontal at 3 m								
No	Frequency (MHz)	EIRP (dBm)	Limit (dBm)	Margin (dB)	Antenna Height (m)	Table Angle (Degree)	Raw Value (dBUV)	Correction Factor (dB/m)
1	404.55	-18.81	-16.02	-2.79	1.00 H	49	81.08	-99.89

Remarks:

1. $EIRP(dBm) = Raw\ Value(dBuV) + Correction\ Factor(dB/m)$
2. $Correction\ Factor(dB/m) = Antenna\ Factor(dB/m) + Cable\ Factor(dB) - Pre-Amplifier\ Factor(dB) + 20\log(D) - 104.8$
3. $Margin\ value = EIRP - Limit\ value$
4. The other EIRP levels were very low against the limit.

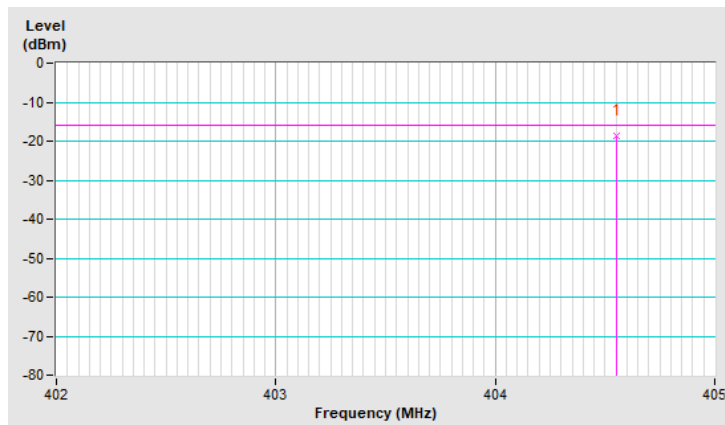

Mode	TX channel 8 (404.55 MHz)	Frequency Range	Below 1000 MHz
Environmental Conditions	22deg. C, 66%RH	Input Power	120Vac, 60Hz
Tested By	Hans Wu		

Antenna Polarity & Test Distance : Vertical at 3m								
No	Frequency (MHz)	EIRP (dBm)	Limit (dBm)	Margin (dB)	Antenna Height (m)	Table Angle (Degree)	Raw Value (dBuV)	Correction Factor (dB/m)
1	404.55	-25.55	-16.02	-9.53	1.10 V	149	74.34	-99.89

Remarks:

1. $EIRP(dBm) = Raw\ Value(dBuV) + Correction\ Factor(dB/m)$
2. $Correction\ Factor(dB/m) = Antenna\ Factor(dB/m) + Cable\ Factor(dB) - Pre-Amplifier\ Factor(dB) + 20\log(D) - 104.8$
3. $Margin\ value = EIRP - Limit\ value$
4. The other EIRP levels were very low against the limit.

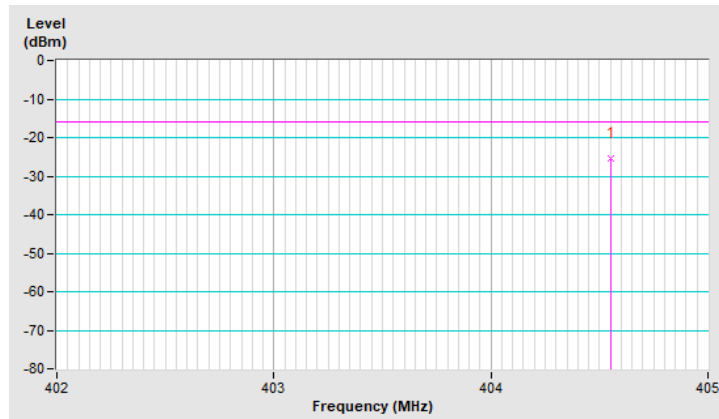

4.5 Transmitter Unwanted Emission

4.5.1 Limits

(a) Emissions from MICS devices more than 250 kHz outside of the 402-405 MHz band shall not exceed the field strength limits specified below:

Frequencies (MHz)	Field Strength (microvolts/meter)	Field Strength (dB μ V/m)	Measurement Distance (meters)
30 ~ 88	100	40	3
88 ~ 216	150	43.5	3
216 ~ 960	200	46	3
Above 960	500	53.9	3

Note:

1. At band edges, the tighter limit applies.
2. Emission level (dB μ V/m) = 20 log Emission level (uV/m).
3. For frequencies above 1000MHz, the field strength limits are based on average detector, however, the peak field strength of any emission shall not exceed the maximum permitted average limits, specified above by more than 20dB under any condition of modulation.
4. Radiated unwanted emissions from a MedRadio transmitter type must be measured to at least the tenth harmonic of the highest fundamental frequency emitted.

(b) Emissions within the 402-405 MHz MICS band which are more than 150 kHz away from the centre frequency of the spectrum, and the transmissions that occupy up to 250 kHz above and below the band shall be attenuated at least 20 dB below the maximum transmitter output power.

4.5.2 Test Instruments

Refer to section 4.4.2 to get information of above instrument.

4.5.3 Test Procedure

For Radiated emission below 30MHz

- a. The EUT was placed on the top of a rotating table 0.8 meters above the ground at a 3 meter chamber room. The table was rotated 360 degrees to determine the position of the highest radiation.
- b. The EUT was set 3 meters away from the interference-receiving antenna, which was mounted on the top of a variable-height antenna tower.
- c. Parallel, perpendicular, and ground-parallel orientations of the antenna are set to make the measurement.
- d. For each suspected emission, the EUT was arranged to its worst case and the rotatable table was turned from 0 degrees to 360 degrees to find the maximum reading.
- e. The test-receiver system was set to Quasi-Peak Detect Function and Specified Bandwidth with Maximum Hold Mode.

NOTE:

1. The resolution bandwidth and video bandwidth of test receiver/spectrum analyzer is 9kHz at frequency below 30MHz.

For Radiated emission above 30MHz

- a. The EUT was placed on the top of a rotating table 0.8 meters (for 30MHz ~ 1GHz) / 1.5 meters (for above 1GHz) above the ground at 3 meter chamber room for test. The table was rotated 360 degrees to determine the position of the highest radiation.
- b. The EUT was set 3 meters away from the interference-receiving antenna, which was mounted on the top of a variable-height antenna tower.
- c. The height of antenna is varied from one meter to four meters above the ground to determine the maximum value of the field strength. Both horizontal and vertical polarizations of the antenna are set to make the measurement.
- d. For each suspected emission, the EUT was arranged to its worst case and then the antenna was tuned to heights from 1 meter to 4 meters and the rotatable table was turned from 0 degrees to 360 degrees to find the maximum reading.
- e. The test-receiver system was set to quasi-peak detect function and specified bandwidth with maximum hold mode when the test frequency is below 1 GHz.
- f. The test-receiver system was set to peak and average detects function and specified bandwidth with maximum hold mode when the test frequency is above 1 GHz. If the peak reading value also meets average limit, measurement with the average detector is unnecessary.

Note:

1. The resolution bandwidth and video bandwidth of test receiver/spectrum analyzer is 120kHz for Quasi-peak detection (QP) at frequency below 1GHz.
2. The resolution bandwidth of test receiver/spectrum analyzer is 1 MHz and the video bandwidth is 3 MHz for Peak detection (PK) at frequency above 1GHz.
3. The resolution bandwidth of test receiver/spectrum analyzer is 1MHz and the video bandwidth is $\geq 1/T$ (Duty cycle < 98%) or 10Hz (Duty cycle $\geq 98\%$) for Average detection (AV) at frequency above 1GHz.
4. All modes of operation were investigated and the worst-case emissions are reported.

4.5.4 Deviation from Test Standard

No deviation

4.5.5 Test Setup

For Radiated Emission below or equal 1GHz

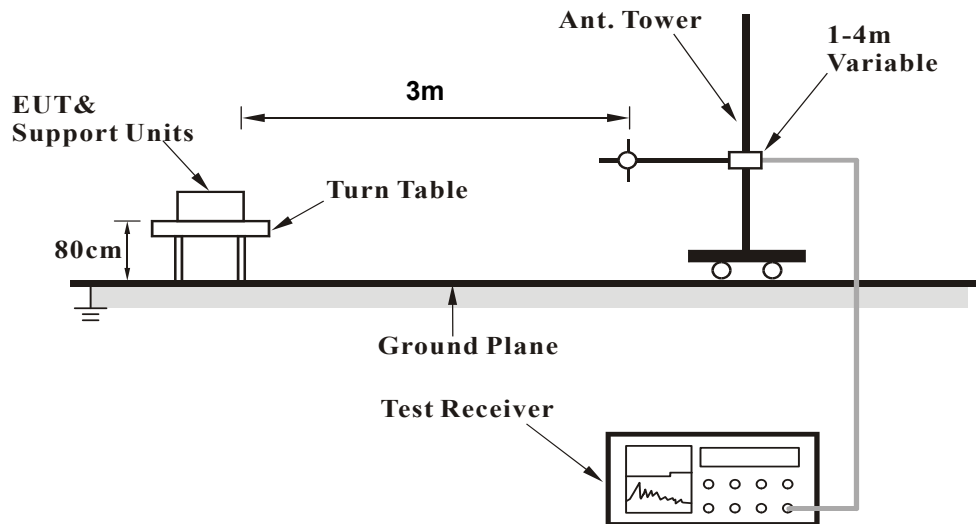

For Radiated Emission above 1GHz

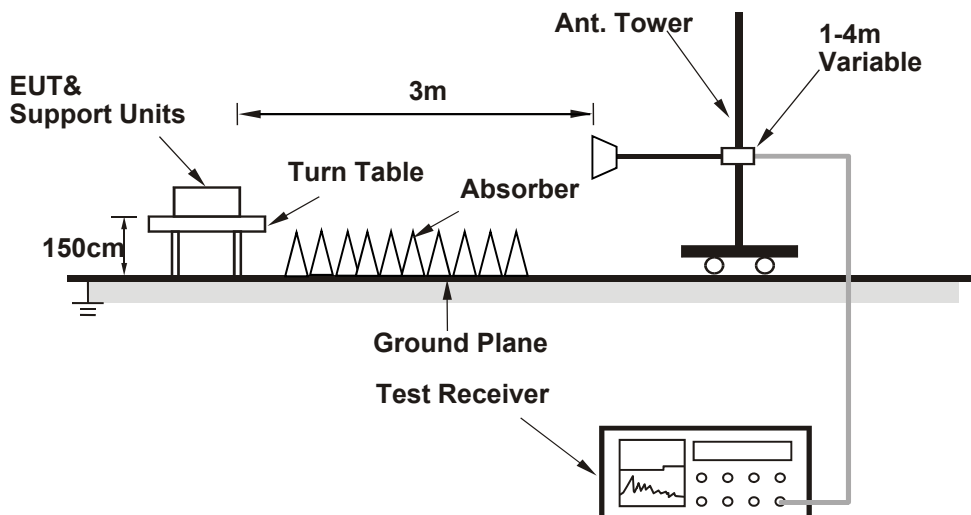

For the actual test configuration, please refer to the attached file (Test Setup Photo).

4.5.6 Test Results

Above 1GHz Data:

CHANNEL	TX Channel 1	DETECTOR FUNCTION	Peak (PK)
FREQUENCY RANGE	1GHz ~ 10GHz		Average (AV)

ANTENNA POLARITY & TEST DISTANCE: HORIZONTAL AT 3 M								
NO.	FREQ. (MHz)	EMISSION LEVEL (dBuV/m)	LIMIT (dBuV/m)	MARGIN (dB)	ANTENNA HEIGHT (m)	TABLE ANGLE (Degree)	RAW VALUE (dBuV)	CORRECTION FACTOR (dB/m)
1	1207.35	38.0 PK	74.0	-36.0	1.76 H	68	43.3	-5.3
2	1207.35	24.1 AV	54.0	-29.9	1.76 H	68	29.4	-5.3

Remarks:

1. Emission Level(dBuV/m) = Raw Value(dBuV) + Correction Factor(dB/m)
2. Correction Factor(dB/m) = Antenna Factor(dB/m) + Cable Factor(dB) – Pre-Amplifier Factor(dB)
3. The other emission levels were very low against the limit.
4. Margin value = Emission Level – Limit value

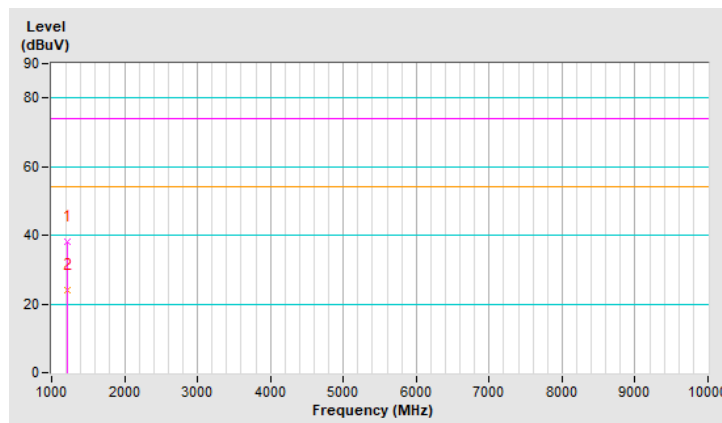

CHANNEL	TX Channel 1	DETECTOR FUNCTION	Peak (PK)
FREQUENCY RANGE	1GHz ~ 10GHz		Average (AV)

ANTENNA POLARITY & TEST DISTANCE: VERTICAL AT 3 M

NO.	FREQ. (MHz)	EMISSION LEVEL (dBuV/m)	LIMIT (dBuV/m)	MARGIN (dB)	ANTENNA HEIGHT (m)	TABLE ANGLE (Degree)	RAW VALUE (dBuV)	CORRECTION FACTOR (dB/m)
1	1207.35	37.1 PK	74.0	-36.9	2.73 V	114	42.4	-5.3
2	1207.35	23.4 AV	54.0	-30.6	2.73 V	114	28.7	-5.3

Remarks:

1. Emission Level(dBuV/m) = Raw Value(dBuV) + Correction Factor(dB/m)
2. Correction Factor(dB/m) = Antenna Factor(dB/m) + Cable Factor(dB) – Pre-Amplifier Factor(dB)
3. The other emission levels were very low against the limit.
4. Margin value = Emission Level – Limit value

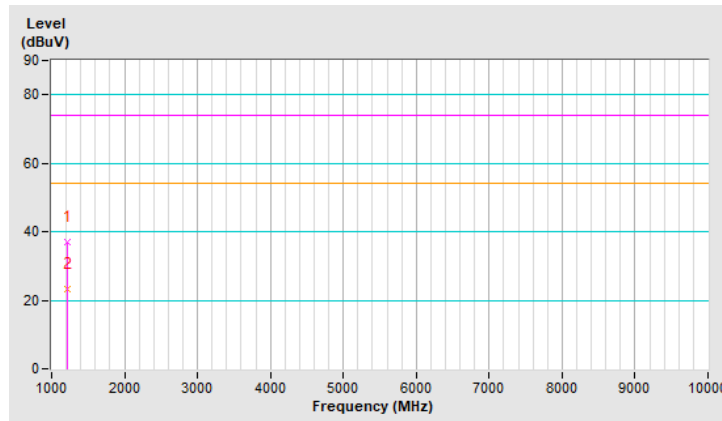

CHANNEL	TX Channel 5	DETECTOR FUNCTION	Peak (PK)
FREQUENCY RANGE	1GHz ~ 10GHz		Average (AV)

ANTENNA POLARITY & TEST DISTANCE: HORIZONTAL AT 3 M								
NO.	FREQ. (MHz)	EMISSION LEVEL (dBuV/m)	LIMIT (dBuV/m)	MARGIN (dB)	ANTENNA HEIGHT (m)	TABLE ANGLE (Degree)	RAW VALUE (dBuV)	CORRECTION FACTOR (dB/m)
1	1210.95	38.5 PK	74.0	-35.5	1.83 H	84	43.7	-5.2
2	1210.95	24.4 AV	54.0	-29.6	1.83 H	84	29.6	-5.2

Remarks:

1. Emission Level(dBuV/m) = Raw Value(dBuV) + Correction Factor(dB/m)
2. Correction Factor(dB/m) = Antenna Factor(dB/m) + Cable Factor(dB) – Pre-Amplifier Factor(dB)
3. The other emission levels were very low against the limit.
4. Margin value = Emission Level – Limit value

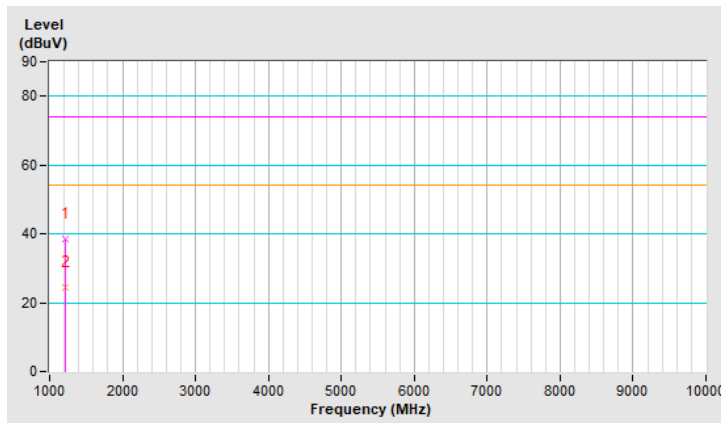

CHANNEL	TX Channel 5	DETECTOR FUNCTION	Peak (PK)
FREQUENCY RANGE	1GHz ~ 10GHz		Average (AV)

ANTENNA POLARITY & TEST DISTANCE: VERTICAL AT 3 M								
NO.	FREQ. (MHz)	EMISSION LEVEL (dBuV/m)	LIMIT (dBuV/m)	MARGIN (dB)	ANTENNA HEIGHT (m)	TABLE ANGLE (Degree)	RAW VALUE (dBuV)	CORRECTION FACTOR (dB/m)
1	1210.95	37.4 PK	74.0	-36.6	2.78 V	123	42.6	-5.2
2	1210.95	23.7 AV	54.0	-30.3	2.78 V	123	28.9	-5.2

Remarks:

1. Emission Level(dBuV/m) = Raw Value(dBuV) + Correction Factor(dB/m)
2. Correction Factor(dB/m) = Antenna Factor(dB/m) + Cable Factor(dB) – Pre-Amplifier Factor(dB)
3. The other emission levels were very low against the limit.
4. Margin value = Emission Level – Limit value

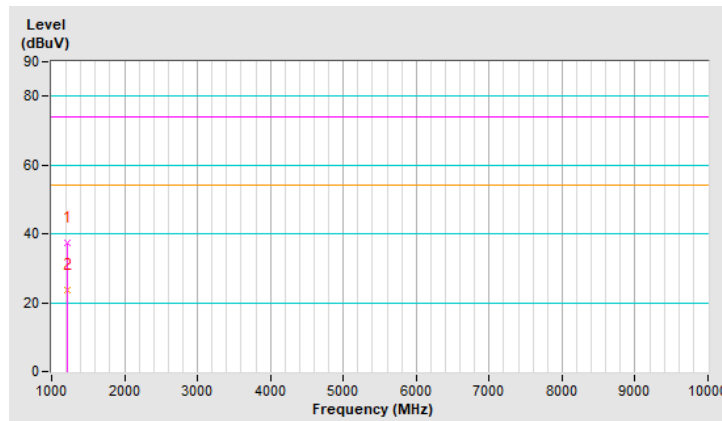

CHANNEL	TX Channel 8	DETECTOR FUNCTION	Peak (PK)
FREQUENCY RANGE	1GHz ~ 10GHz		Average (AV)

ANTENNA POLARITY & TEST DISTANCE: HORIZONTAL AT 3 M

NO.	FREQ. (MHz)	EMISSION LEVEL (dBuV/m)	LIMIT (dBuV/m)	MARGIN (dB)	ANTENNA HEIGHT (m)	TABLE ANGLE (Degree)	RAW VALUE (dBuV)	CORRECTION FACTOR (dB/m)
1	1213.65	38.6 PK	74.0	-35.4	1.73 H	79	43.7	-5.1
2	1213.65	24.5 AV	54.0	-29.5	1.73 H	79	29.6	-5.1

Remarks:

1. Emission Level(dBuV/m) = Raw Value(dBuV) + Correction Factor(dB/m)
2. Correction Factor(dB/m) = Antenna Factor(dB/m) + Cable Factor(dB) – Pre-Amplifier Factor(dB)
3. The other emission levels were very low against the limit.
4. Margin value = Emission Level – Limit value

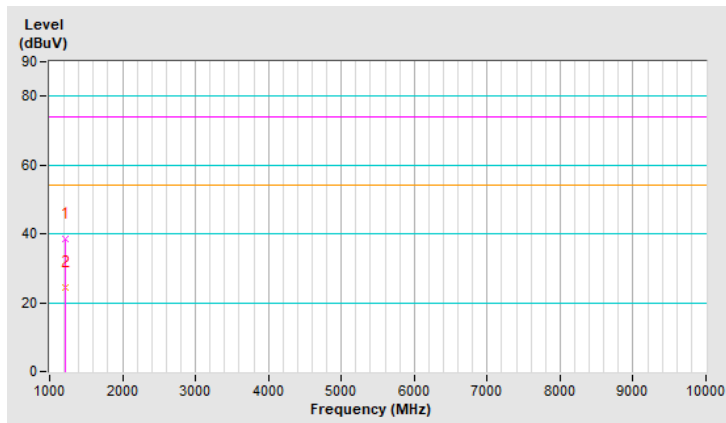

CHANNEL	TX Channel 8	DETECTOR FUNCTION	Peak (PK)
FREQUENCY RANGE	1GHz ~ 10GHz		Average (AV)

ANTENNA POLARITY & TEST DISTANCE: VERTICAL AT 3 M								
NO.	FREQ. (MHz)	EMISSION LEVEL (dBuV/m)	LIMIT (dBuV/m)	MARGIN (dB)	ANTENNA HEIGHT (m)	TABLE ANGLE (Degree)	RAW VALUE (dBuV)	CORRECTION FACTOR (dB/m)
1	1213.65	37.7 PK	74.0	-36.3	2.80 V	117	42.8	-5.1
2	1213.65	24.0 AV	54.0	-30.0	2.80 V	117	29.1	-5.1

Remarks:

1. Emission Level(dBuV/m) = Raw Value(dBuV) + Correction Factor(dB/m)
2. Correction Factor(dB/m) = Antenna Factor(dB/m) + Cable Factor(dB) – Pre-Amplifier Factor(dB)
3. The other emission levels were very low against the limit.
4. Margin value = Emission Level – Limit value

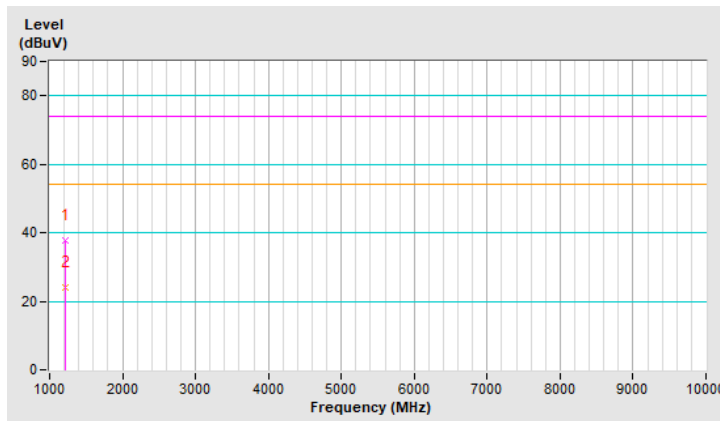

Below 1GHz data:

CHANNEL	TX Channel 1	DETECTOR FUNCTION	Quasi-Peak (QP)
FREQUENCY RANGE	30MHz ~ 1GHz		

ANTENNA POLARITY & TEST DISTANCE: HORIZONTAL AT 3 M								
NO.	FREQ. (MHz)	EMISSION LEVEL (dBuV/m)	LIMIT (dBuV/m)	MARGIN (dB)	ANTENNA HEIGHT (m)	TABLE ANGLE (Degree)	RAW VALUE (dBuV)	CORRECTION FACTOR (dB/m)
1	58.13	17.3 QP	40.0	-22.7	1.82 H	68	26.6	-9.3
2	330.70	21.6 QP	46.0	-24.4	2.01 H	57	27.4	-5.8
3	654.68	29.2 QP	46.0	-16.8	3.37 H	359	28.7	0.5
4	748.77	31.0 QP	46.0	-15.0	3.72 H	275	28.6	2.4
5	804.90	32.9 QP	46.0	-13.1	3.00 H	219	29.4	3.5
6	969.93	33.8 QP	54.0	-20.2	1.85 H	7	27.2	6.6

Remarks:

1. Emission Level(dBuV/m) = Raw Value(dBuV) + Correction Factor(dB/m)
2. Correction Factor(dB/m) = Antenna Factor(dB/m) + Cable Factor(dB) – Pre-Amplifier Factor(dB)
3. Margin value = Emission Level – Limit value
4. The other emission levels were very low against the limit of frequency range 30MHz~1000MHz.
5. The emission levels were very low against the limit of frequency range 9kHz~30MHz: the amplitude of spurious emissions attenuated more than 20 dB below the permissible value to be report.

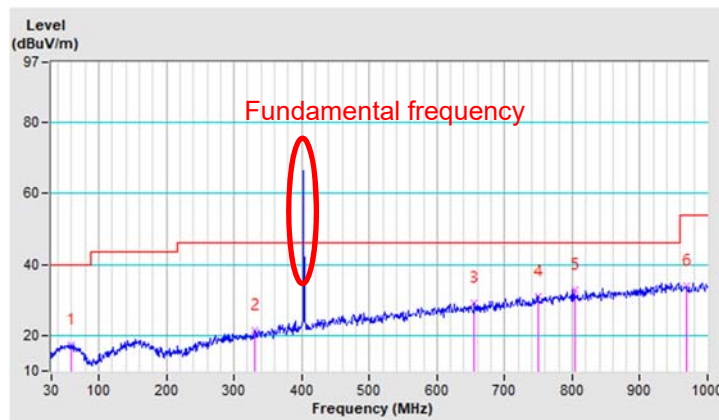

CHANNEL	TX Channel 1	DETECTOR FUNCTION	Quasi-Peak (QP)
FREQUENCY RANGE	30MHz ~ 1GHz		

ANTENNA POLARITY & TEST DISTANCE: VERTICAL AT 3 M								
NO.	FREQ. (MHz)	EMISSION LEVEL (dBuV/m)	LIMIT (dBuV/m)	MARGIN (dB)	ANTENNA HEIGHT (m)	TABLE ANGLE (Degree)	RAW VALUE (dBuV)	CORRECTION FACTOR (dB/m)
1	274.44	20.6 QP	46.0	-25.4	2.55 V	299	28.0	-7.4
2	462.62	26.0 QP	46.0	-20.0	2.75 V	15	28.9	-2.9
3	601.33	27.5 QP	46.0	-18.5	3.82 V	171	27.7	-0.2
4	728.40	31.3 QP	46.0	-14.7	1.34 V	228	29.5	1.8
5	804.90	32.1 QP	46.0	-13.9	2.58 V	269	28.6	3.5
6	968.96	35.3 QP	54.0	-18.7	2.39 V	345	28.7	6.6

Remarks:

1. Emission Level(dBuV/m) = Raw Value(dBuV) + Correction Factor(dB/m)
2. Correction Factor(dB/m) = Antenna Factor(dB/m) + Cable Factor(dB) – Pre-Amplifier Factor(dB)
3. Margin value = Emission Level – Limit value
4. The other emission levels were very low against the limit of frequency range 30MHz~1000MHz.
5. The emission levels were very low against the limit of frequency range 9kHz~30MHz: the amplitude of spurious emissions attenuated more than 20 dB below the permissible value to be report.

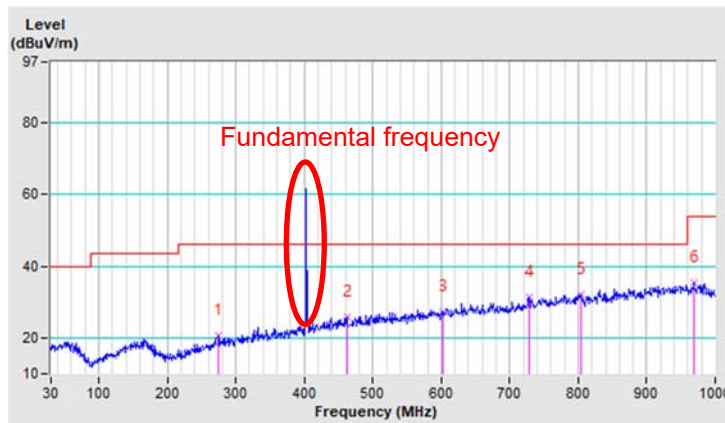

CHANNEL	TX Channel 5	DETECTOR FUNCTION	Quasi-Peak (QP)
FREQUENCY RANGE	30MHz ~ 1GHz		

ANTENNA POLARITY & TEST DISTANCE: HORIZONTAL AT 3 M								
NO.	FREQ. (MHz)	EMISSION LEVEL (dBuV/m)	LIMIT (dBuV/m)	MARGIN (dB)	ANTENNA HEIGHT (m)	TABLE ANGLE (Degree)	RAW VALUE (dBuV)	CORRECTION FACTOR (dB/m)
1	55.22	18.4 QP	40.0	-21.6	1.56 H	315	27.5	-9.1
2	322.94	21.8 QP	46.0	-24.2	1.77 H	138	27.9	-6.1
3	525.67	26.4 QP	46.0	-19.6	1.23 H	188	28.1	-1.7
4	697.36	29.8 QP	46.0	-16.2	1.47 H	74	28.7	1.1
5	807.30	33.0 QP	46.0	-13.0	2.83 H	239	29.5	3.5
6	974.78	34.1 QP	54.0	-19.9	3.05 H	88	27.5	6.6

Remarks:

1. Emission Level(dBuV/m) = Raw Value(dBuV) + Correction Factor(dB/m)
2. Correction Factor(dB/m) = Antenna Factor(dB/m) + Cable Factor(dB) – Pre-Amplifier Factor(dB)
3. Margin value = Emission Level – Limit value
4. The other emission levels were very low against the limit of frequency range 30MHz~1000MHz.
5. The emission levels were very low against the limit of frequency range 9kHz~30MHz: the amplitude of spurious emissions attenuated more than 20 dB below the permissible value to be report.

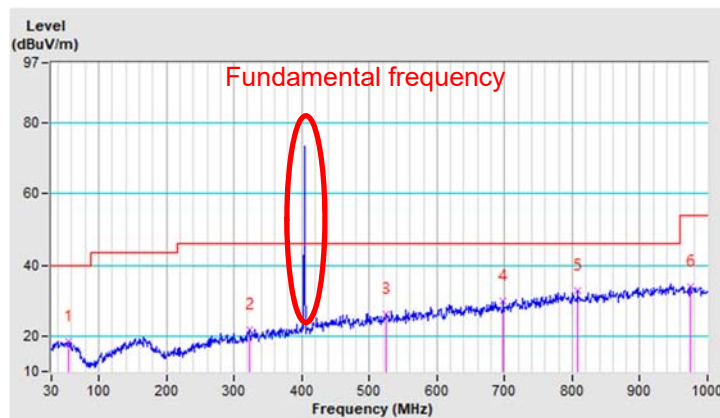

CHANNEL	TX Channel 5	DETECTOR FUNCTION	Quasi-Peak (QP)
FREQUENCY RANGE	30MHz ~ 1GHz		

ANTENNA POLARITY & TEST DISTANCE: VERTICAL AT 3 M								
NO.	FREQ. (MHz)	EMISSION LEVEL (dBuV/m)	LIMIT (dBuV/m)	MARGIN (dB)	ANTENNA HEIGHT (m)	TABLE ANGLE (Degree)	RAW VALUE (dBuV)	CORRECTION FACTOR (dB/m)
1	56.19	17.9 QP	40.0	-22.1	2.59 V	238	27.0	-9.1
2	259.89	19.8 QP	46.0	-26.2	2.57 V	75	28.2	-8.4
3	547.98	27.4 QP	46.0	-18.6	1.92 V	222	28.9	-1.5
4	807.30	32.8 QP	46.0	-13.2	1.71 V	302	29.3	3.5
5	872.93	34.4 QP	46.0	-11.6	3.47 V	52	29.5	4.9
6	984.48	34.5 QP	54.0	-19.5	2.27 V	59	27.9	6.6

Remarks:

1. Emission Level(dBuV/m) = Raw Value(dBuV) + Correction Factor(dB/m)
2. Correction Factor(dB/m) = Antenna Factor(dB/m) + Cable Factor(dB) – Pre-Amplifier Factor(dB)
3. Margin value = Emission Level – Limit value
4. The other emission levels were very low against the limit of frequency range 30MHz~1000MHz.
5. The emission levels were very low against the limit of frequency range 9kHz~30MHz: the amplitude of spurious emissions attenuated more than 20 dB below the permissible value to be report.

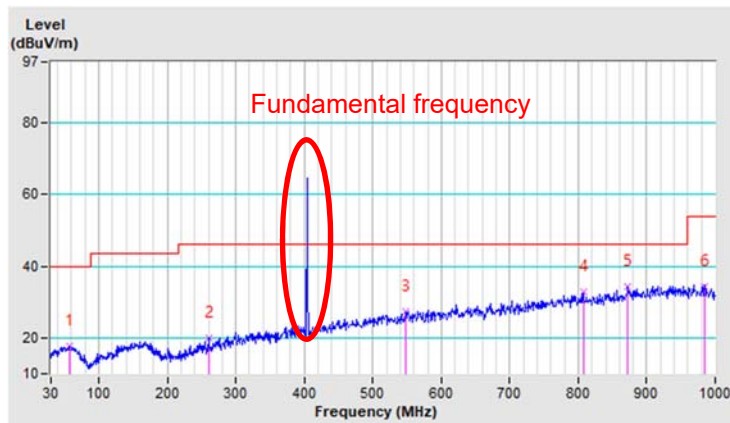

CHANNEL	TX Channel 8	DETECTOR FUNCTION	Quasi-Peak (QP)
FREQUENCY RANGE	30MHz ~ 1GHz		

ANTENNA POLARITY & TEST DISTANCE: HORIZONTAL AT 3 M								
NO.	FREQ. (MHz)	EMISSION LEVEL (dBuV/m)	LIMIT (dBuV/m)	MARGIN (dB)	ANTENNA HEIGHT (m)	TABLE ANGLE (Degree)	RAW VALUE (dBuV)	CORRECTION FACTOR (dB/m)
1	147.37	18.6 QP	43.5	-24.9	3.06 H	112	27.3	-8.7
2	307.42	20.5 QP	46.0	-25.5	1.45 H	50	26.8	-6.3
3	485.90	25.6 QP	46.0	-20.4	3.01 H	62	28.2	-2.6
4	661.47	29.3 QP	46.0	-16.7	3.55 H	251	28.7	0.6
5	809.10	31.7 QP	46.0	-14.3	1.61 H	260	28.2	3.5
6	968.96	34.8 QP	54.0	-19.2	2.14 H	124	28.2	6.6

Remarks:

1. Emission Level(dBuV/m) = Raw Value(dBuV) + Correction Factor(dB/m)
2. Correction Factor(dB/m) = Antenna Factor(dB/m) + Cable Factor(dB) – Pre-Amplifier Factor(dB)
3. Margin value = Emission Level – Limit value
4. The other emission levels were very low against the limit of frequency range 30MHz~1000MHz.
5. The emission levels were very low against the limit of frequency range 9kHz~30MHz: the amplitude of spurious emissions attenuated more than 20 dB below the permissible value to be report.

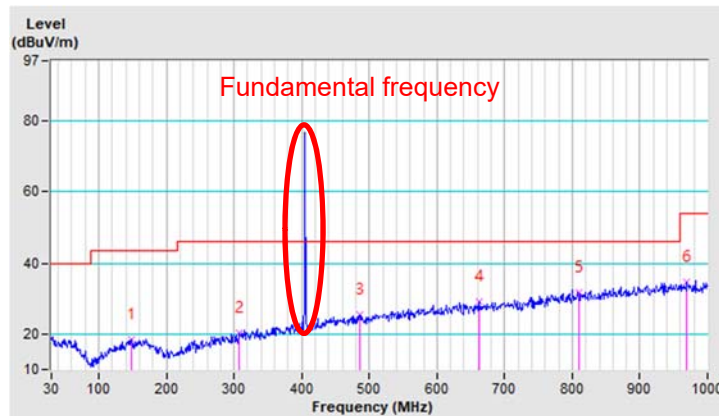

CHANNEL	TX Channel 8	DETECTOR FUNCTION	Quasi-Peak (QP)
FREQUENCY RANGE	30MHz ~ 1GHz		

ANTENNA POLARITY & TEST DISTANCE: VERTICAL AT 3 M								
NO.	FREQ. (MHz)	EMISSION LEVEL (dBuV/m)	LIMIT (dBuV/m)	MARGIN (dB)	ANTENNA HEIGHT (m)	TABLE ANGLE (Degree)	RAW VALUE (dBuV)	CORRECTION FACTOR (dB/m)
1	61.04	18.6 QP	40.0	-21.4	2.74 V	151	28.4	-9.8
2	250.19	18.6 QP	46.0	-27.4	2.34 V	45	27.3	-8.7
3	561.56	27.5 QP	46.0	-18.5	3.25 V	218	28.6	-1.1
4	685.72	29.8 QP	46.0	-16.2	1.12 V	288	28.7	1.1
5	809.10	31.8 QP	46.0	-14.2	1.10 V	260	28.3	3.5
6	977.69	34.3 QP	54.0	-19.7	2.92 V	207	27.7	6.6

Remarks:

1. Emission Level(dBuV/m) = Raw Value(dBuV) + Correction Factor(dB/m)
2. Correction Factor(dB/m) = Antenna Factor(dB/m) + Cable Factor(dB) – Pre-Amplifier Factor(dB)
3. Margin value = Emission Level – Limit value
4. The other emission levels were very low against the limit of frequency range 30MHz~1000MHz.
5. The emission levels were very low against the limit of frequency range 9kHz~30MHz: the amplitude of spurious emissions attenuated more than 20 dB below the permissible value to be report.

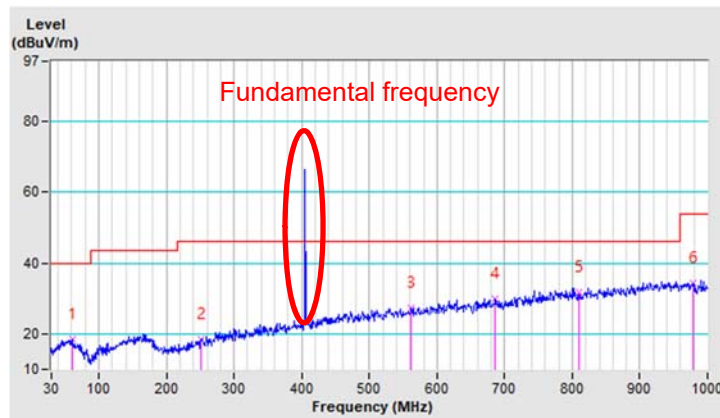

4.6 MedRadio Channel Access

4.6.1 LBT threshold power level

4.6.1.1 Limits

The monitoring system threshold power level, PTh (dBm) shall not be greater than the calculated level given by the equation: $10 \log B \text{ (Hz)} - 150 + G \text{ (dBi)}$, where B is the emission bandwidth of the MICS communication session transmitter having the widest emission bandwidth and G is the ULP-AMI-P monitoring system antenna gain relative to an isotropic antenna.

If an ULP-AMI device is used to select the frequency of operation for a MICS system, the above LBT threshold level requirement may be adjusted higher by 1 dB for every 1 dB the ERP of the device performing the LBT and AFA function is below the maximum permitted level of -16dBm. However, no other device operating in the MICL shall have an ERP greater than the device that selects the frequency of operation for the MICL. Thus, for a specific system a device whose output ERP is 10 dB lower than the maximum permitted level of -16dBm may add +10 dB to the above equation. This adjustment will permit implanted devices to provide the LBT and AFA function where antenna gain and body absorption significantly affect monitoring system sensitivity relative to external programmer/controllers.

4.6.1.2 Test Procedure

1. Configure the test setup as defined in Section 3.2.
2. Setup the blocking band signal generator. Adjust the blocking band power level to 3 dB above the calculated threshold power level.
3. Setup the on channel signal generator for continuous wave output, 6 dB below the calculated threshold power level, at the center frequency of the open channel in the blocking band.
4. Verify that the session starts on the blocking band open channel (Channel 5).
5. Wait for the telemetry session to end.
6. Increase the on channel interferer signal level 1 dB from the following test and repeat Steps 4 and 5.
7. Repeat Step 6 until the device does not attempt to start a telemetry session due to all channels being above the LBT threshold. Record the on channel signal generator level.
8. Subtract 4 dB from the on channel signal level recorded in Step 8 to calculate the measured threshold power level.

4.6.1.3 Deviation from Test Standard

No deviation.

4.6.1.4 Out-of-operating-region disturbance used

Out-of-operating-region disturbance is generated by using a disturbance source that can generate a sufficient number (approximately $2 \times 3000 / \text{emission bandwidth in kHz}$) of independently-controlled CW signals across the 402 MHz to 405 MHz band to block access to the band except for a notch or notches equal to twice the emission bandwidth of the EUT.

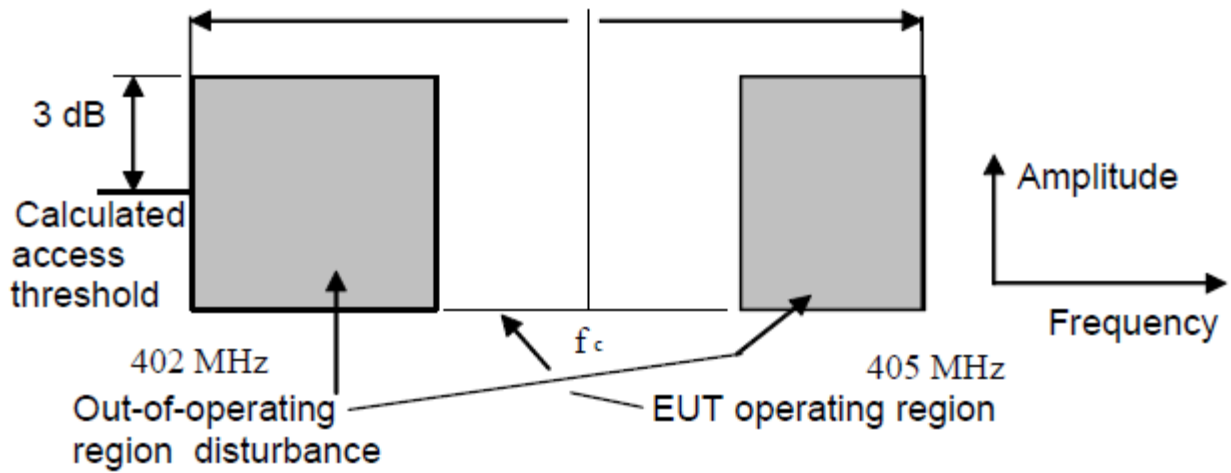

4.6.1.5 Test Results and Graphics

Temperature	Tnom
Voltage	Vnom
Channel	(CH5) 403.65 MHz
LBT threshold power level (dBm)	-103.3-4=-107.3
Largest Emission Bandwidth (kHz)	251
Lowest Antenna Gain (dBi)	-8.7
Limit (dBm)	-104.7
Conclusion	Pass

Note: For all measurement, an offset of 22.0dB was used due to the path losses.

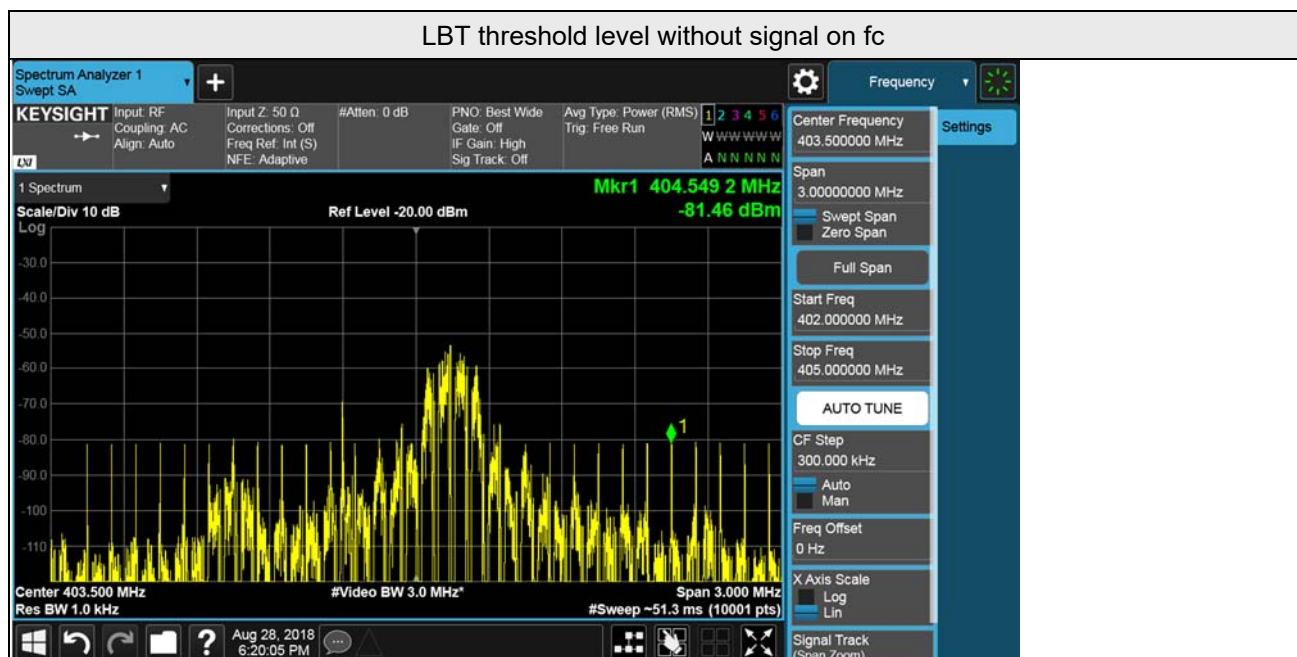
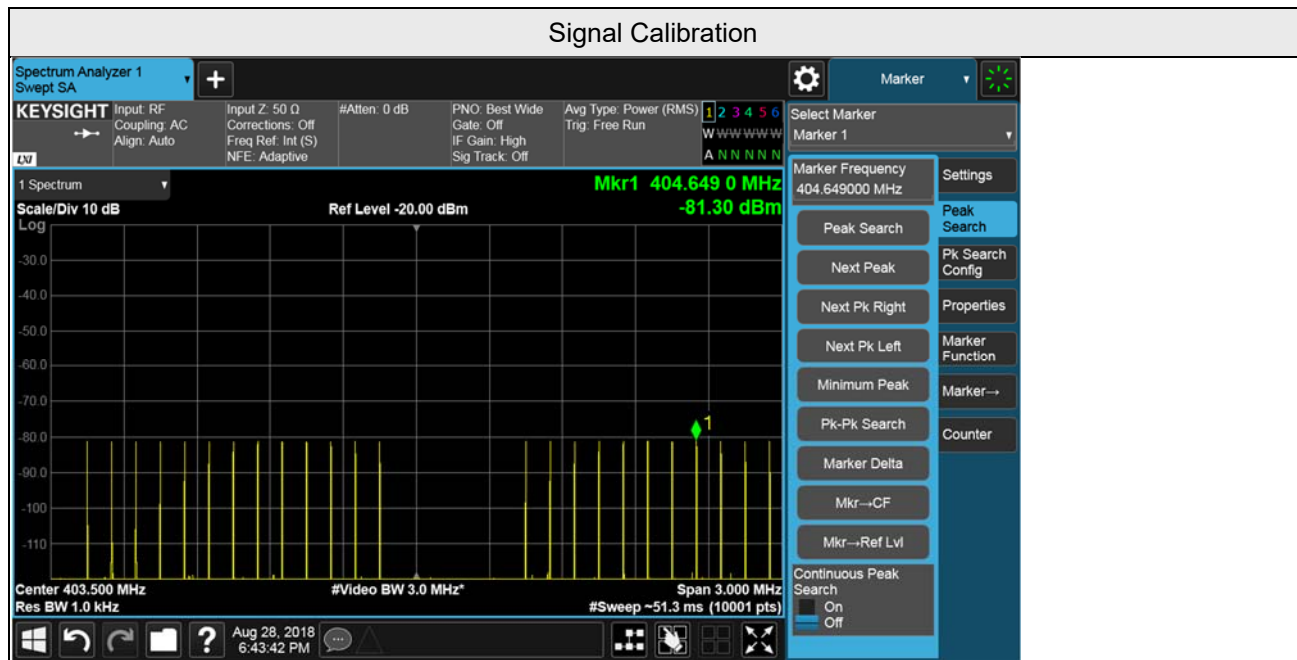

LBT threshold level with signal on $f_c = -102.5$ dBm

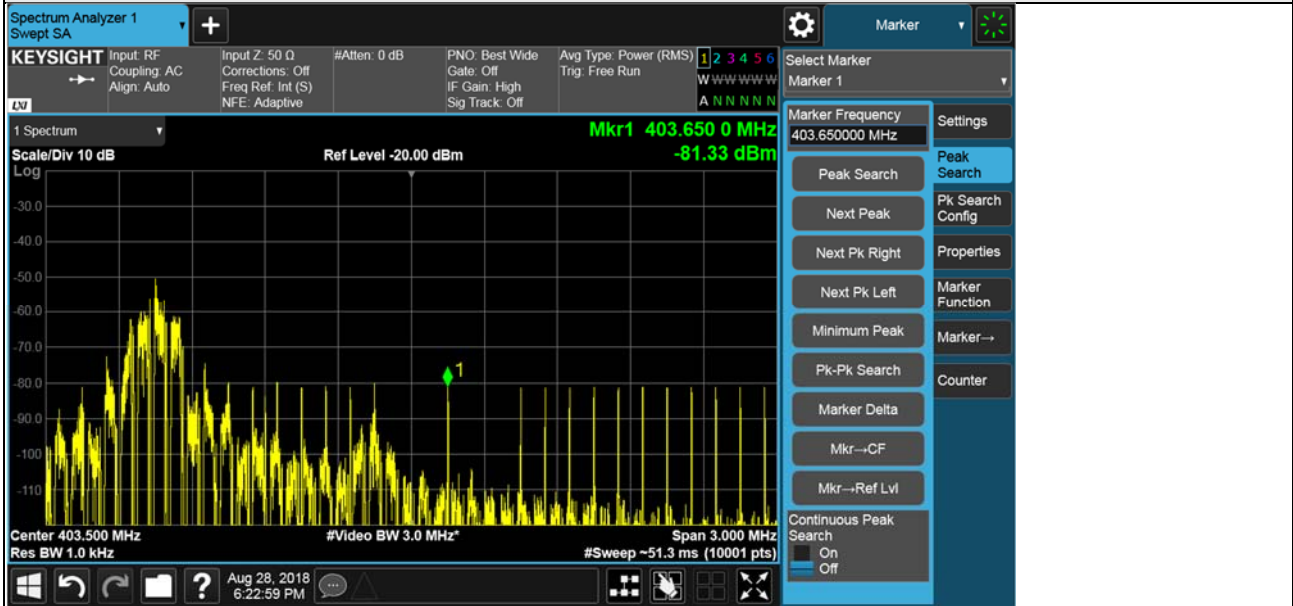

LBT threshold level with signal on $f_c = -103.5$ dBm



4.6.2 Monitoring system bandwidth

4.6.2.1 Limits

The monitoring system bandwidth measured at its 20dB down points shall be equal to or greater than the emission bandwidth of the intended transmission. The requirement is met if Pb-Pa & Pc-Pa are less than or equal to 20dB.

4.6.2.2 Test Procedure

1. Configure the test setup as defined in Section 3.2.
2. Setup the blocking band signal generator. Adjust the blocking band power level to 3 dB above the calculated threshold power level.
3. Setup the on channel signal generator for continuous wave output, 6 dB above the calculated threshold power level, at the center frequency of the open channel in the blocking band.
4. Start an RF telemetry session.
5. Verify that the device does not attempt to start a telemetry session due to all channels being above the LBT threshold.
6. Decrease the on channel interferer signal level 1 dB from the following test and repeat Steps 4 and 5.
7. Repeat Step 6 until the session is started on Channel 5. Record the on channel signal generator level as Pa. Wait for the telemetry session to end
8. Set the on channel signal generator frequency 150 kHz lower than the value set in Step 3 to simulate the PG TX emissions bandwidth low frequency.
9. Start an RF telemetry. Verify that the session starts on the blocking band open channel (Channel 5).
10. Wait for the telemetry session to end.
11. Increase the on channel interferer signal level 1 dB from the following test and repeat Steps 9 and 10.
12. Repeat Step 11 until the device does not attempt to start a telemetry session due to all channels being above the LBT threshold. Record the on channel signal generator level as Pb.
13. Set the on channel signal generator frequency 150 kHz higher than the value set in Step 3 to simulate the PG TX emissions bandwidth high frequency with signal level of Pa.
14. Verify that the session starts on the blocking band open channel (Channel 5).
15. Wait for the telemetry session to end.
16. Increase the on channel interferer signal level 1 dB from the following test and repeat Steps 14 and 15.
17. Repeat Step 16 until the device does not attempt to start a telemetry session due to all channels being above the LBT threshold. Record the on channel signal generator level as Pc.
18. Subtract Pa from Pb and record the difference as D1.
19. Subtract Pa from Pc and record the difference as D2

4.6.2.3 Deviation from Test Standard

No deviation.

4.6.2.4 Out-of-operating-region disturbance used

Out-of-operating-region disturbance is generated by using a disturbance source that can generate a sufficient number (approximately $2 \times 3000 / \text{emission bandwidth in kHz}$) of independently-controlled CW signals across the 402 MHz to 405 MHz band to block access to the band except for a notch or notches equal to twice the emission bandwidth of the EUT.

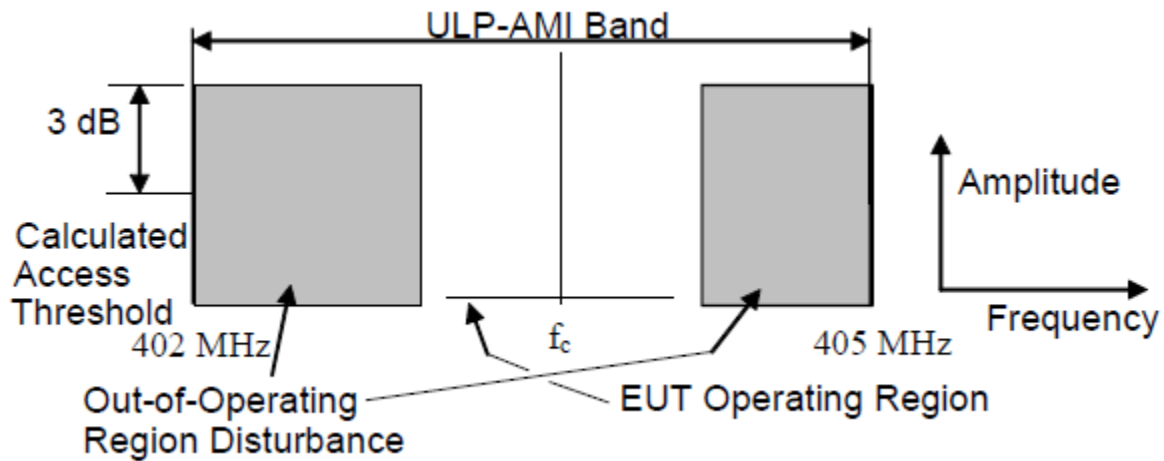

4.6.2.5 Test Results and Graphics

Temperature	Tnom
Voltage	Vnom
Channel	(CH5) 403.65 MHz
Pa (dBm)	-98.41
Pb (dBm)	-91.19
Pc (dBm)	-88.22
Pb - Pa (dB)	7.22
Pc - Pa (dB)	10.19
Conclusion, (≤ 20 dB)	Pass

Note: For all measurement, an offset of 22.0dB was used due to the path losses.

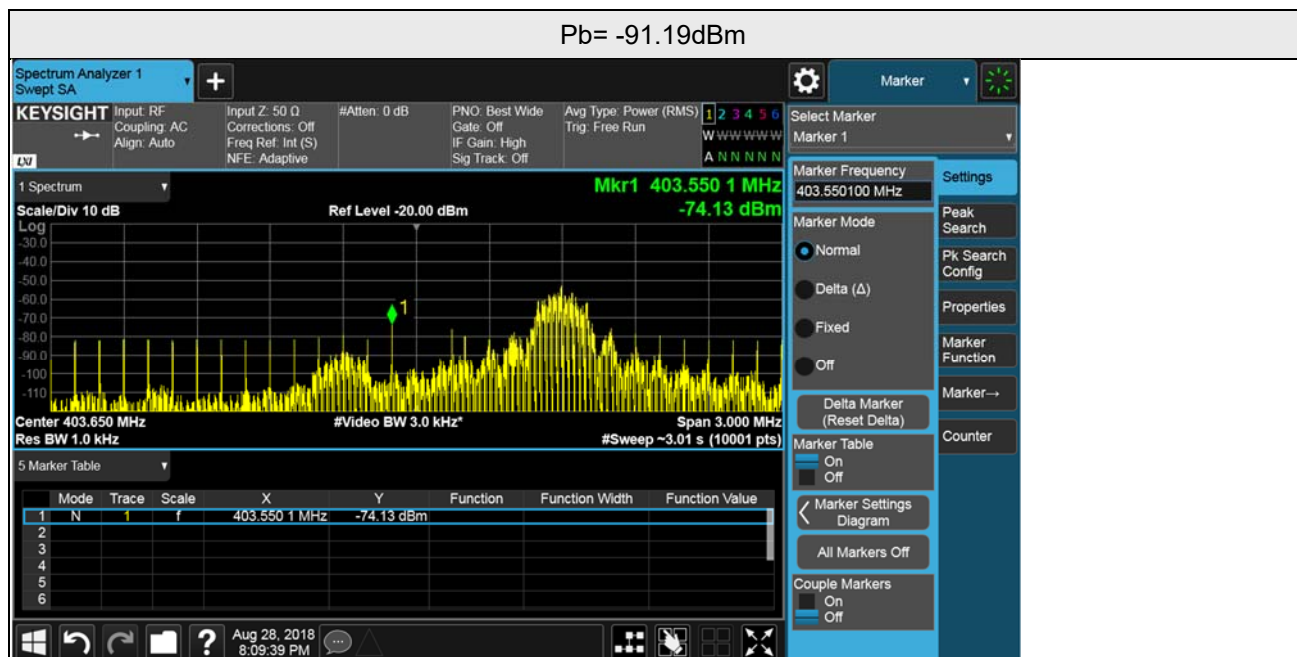
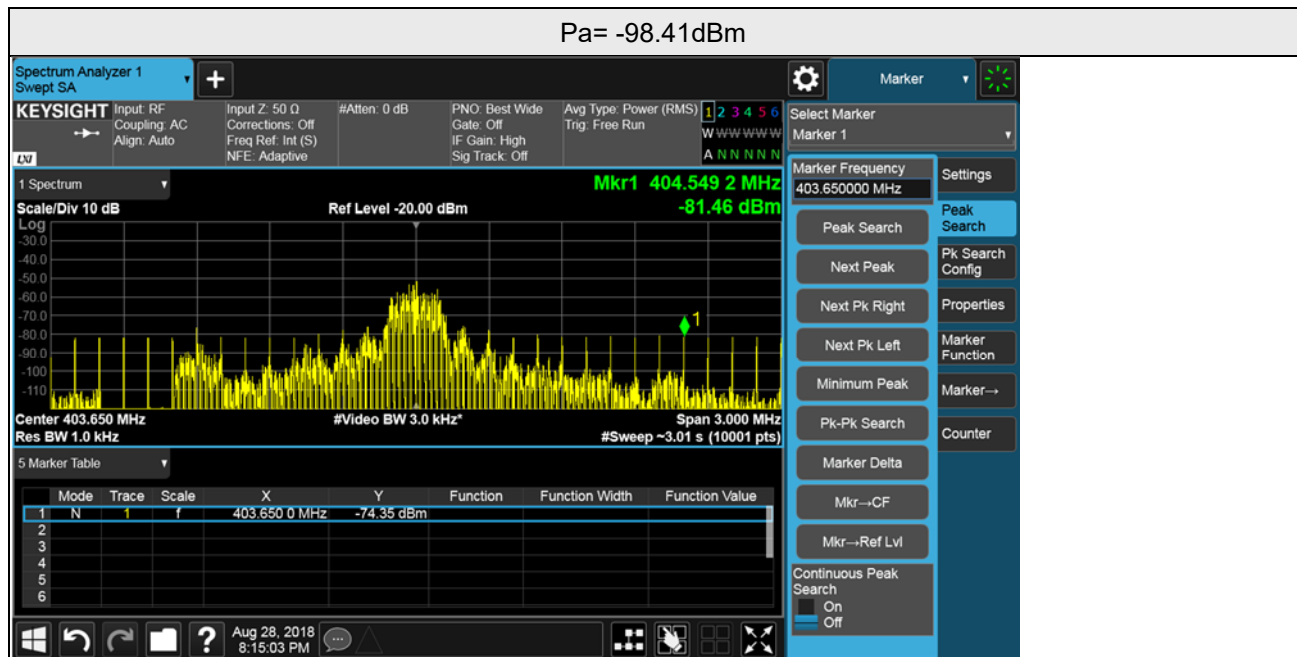

Pc= -88.22dBm

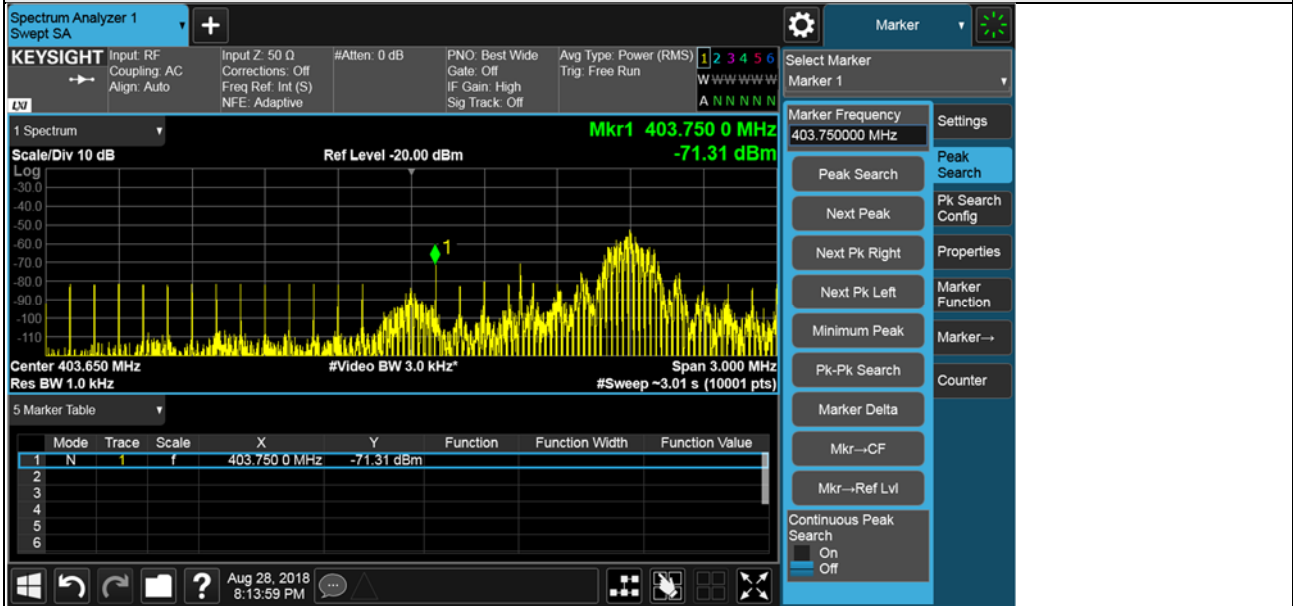

4.6.3 Monitoring system scan cycle time and minimum channel monitoring period

4.6.3.1 Limits

Monitoring system scan cycle time: Scan cycle time shall not exceed 5 seconds.

Minimum channel monitoring period: The EUT shall initiate communications session on fc.

4.6.3.2 Test Procedure

Monitoring system scan cycle time

1. Configure the test setup as defined in Section 3.2.
2. Setup the blocking band signal generator. Adjust the blocking band power level to 3 dB above the calculated threshold power level.
3. Setup the on channel signal generator for continuous wave output, 6 dB above the calculated threshold power level, at the center frequency of the open channel in the blocking band.
4. Start an RF telemetry session.
5. Verify that the device does not attempt to start a telemetry session due to all channels being above the LBT threshold.
6. Set the spectrum analyzer as follows
 - a. Span: zero span
 - b. Frequency: Channel 5 frequency (403.65 MHz)
 - c. Sweep time: 10 seconds
 - d. Sweep: Single
7. Trigger a spectrum analyzer sweep. When the sweep has hit ~ 5seconds, remove the on channel generator signal (RF off) and start an RF telemetry session.
8. Verify that the session starts on Channel 5 and measure the time from when the session was requested and the DUT TX starts.
9. Repeat Steps 7 and 8 four additional times (for a total of five) to show repeatability.

Minimum channel monitoring period

1. Configure the test setup as defined in Section 3.2.
2. Setup the blocking band signal generator.

Adjust the blocking band power level to 3 dB above the calculated threshold power level.
3. Start an RF telemetry session. Verify that the session starts on the blocking band open channel (Channel 5).
4. Wait for the telemetry session to end.
5. Setup the on channel signal generator for continuous wave output, 3 dB above the calculated threshold power level, at the center frequency of the open channel in the blocking band.
6. Remove the blocking band generator signal (RF off).
7. Start an RF telemetry session. Verify that the session starts on one of the blocking band wake-up channels.
8. Wait for the telemetry session to end.
9. Turn the blocking band generator signal on (RF on) at a power level 6 dB above the calculated threshold power level. The on channel signal generator should still be on, with signal level 3 dB above the calculated threshold power level.
10. Start an RF telemetry session .
11. Verify that the device does not attempt to start a telemetry session due to all channels being above the LBT threshold.
12. Repeat steps 10 and 11 four additional times (for a total of five).
13. Modulate the blocking band generator output so that it is on for 0.1 ms during a 10 ms period.
14. Start an RF telemetry session.
15. Verify that the device does not attempt to start a telemetry session due to all channels being above the LBT threshold.
16. Repeat steps 14 and 15 nine additional times (for a total of ten).

4.6.3.3 Deviation from Test Standard

No deviation.

4.6.3.4 Out-of-operating-region disturbance used

Out-of-operating-region disturbance is generated by using a disturbance source that can generate a sufficient number (approximately $2 \times 3000 / \text{emission bandwidth in kHz}$) of independently-controlled CW signals across the 402 MHz to 405 MHz band to block access to the band except for a notch or notches equal to twice the emission bandwidth of the EUT.

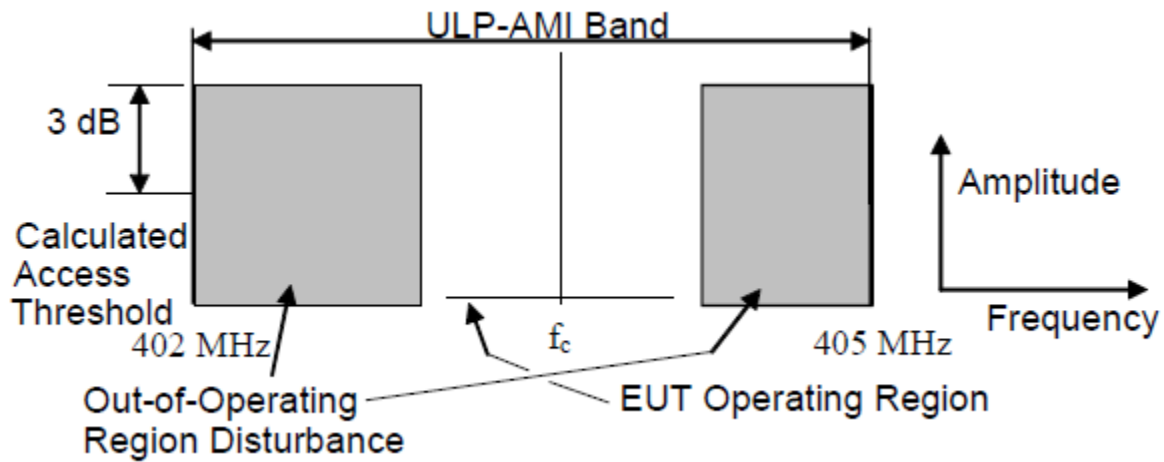

4.6.3.5 Test Results and Graphics

Monitoring system scan cycle time: Scan cycle time shall not exceed 5 seconds

Temperature	Tnom
Voltage	Vnom
Channel	(CH5) 403.65 MHz
Tp Scan Cycle Time (s)	3.838
Tp1 Scan Cycle Time (s)	3.193
Tp2 Scan Cycle Time (s)	4.065
Conclusion, $\leq 5(s)$	Pass

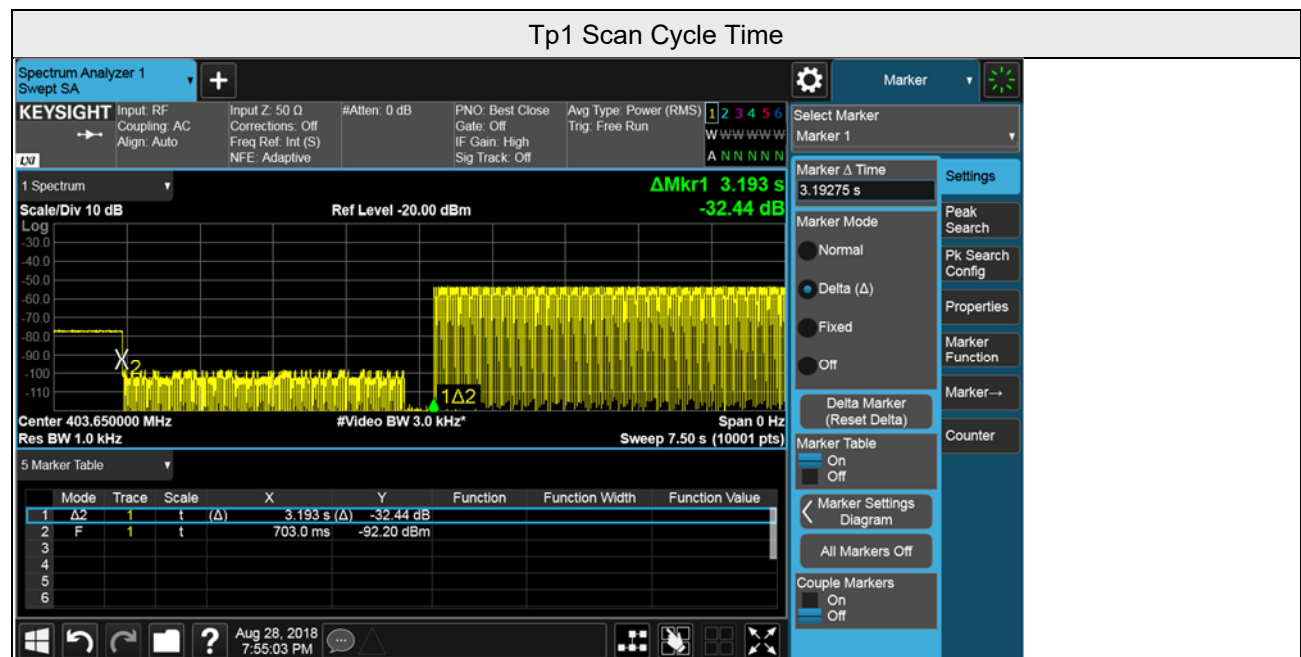
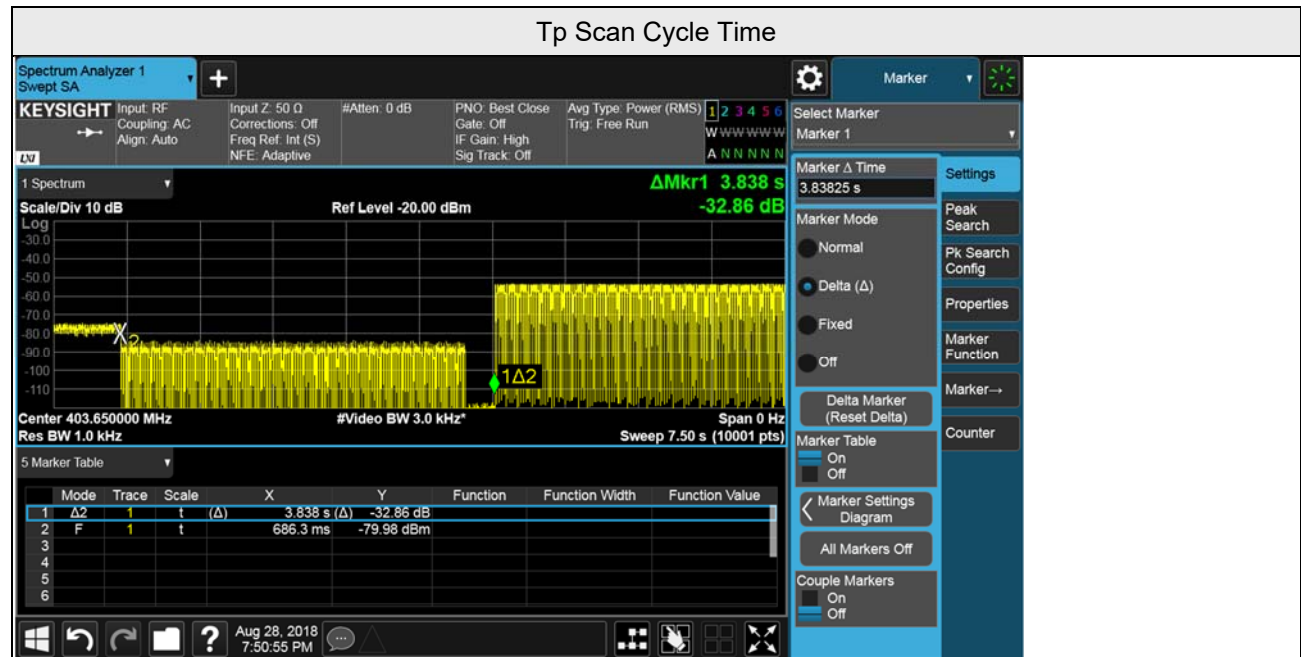

Tp2 Scan Cycle Time

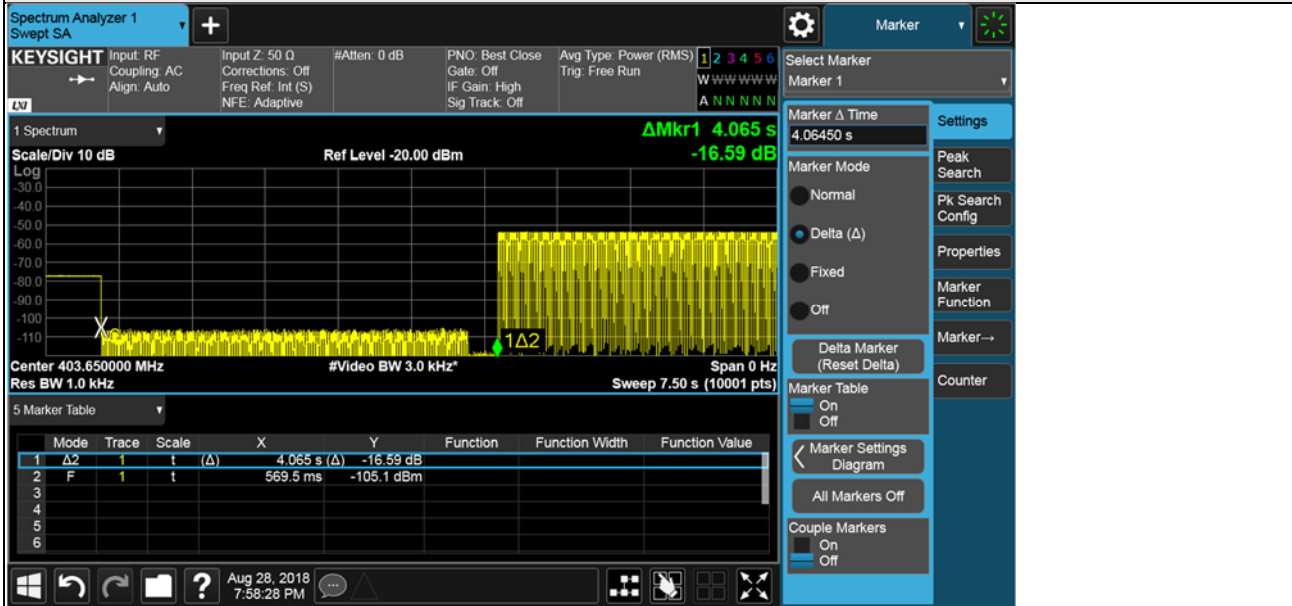

Minimum channel monitoring period: The EUT shall initiate communications session on fc.

Temperature	Tnom
Voltage	Vnom
Channel	(CH5) 403.65 MHz
Conclusion	Pass

Minimum channel monitoring period

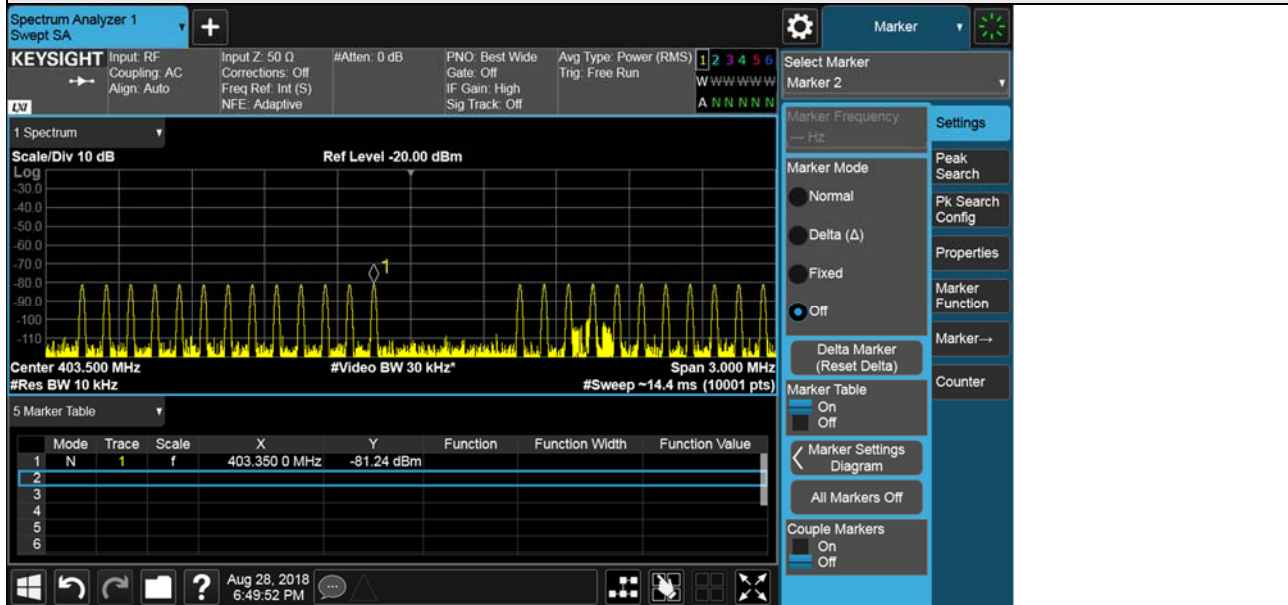

Minimum channel monitoring period

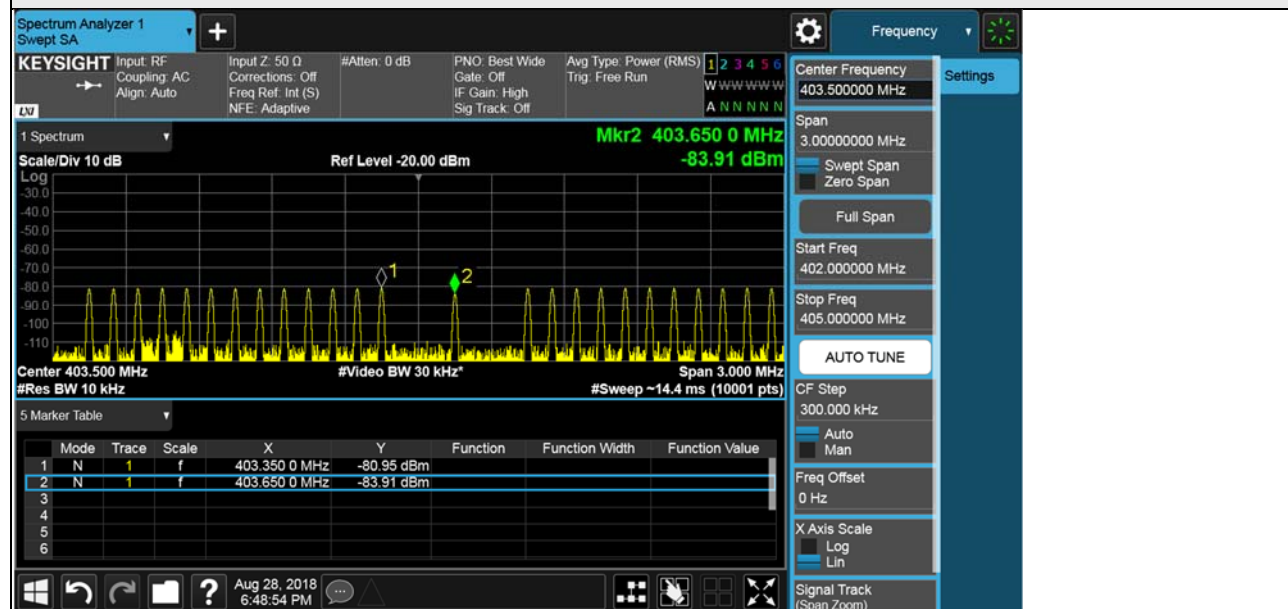

Minimum channel monitoring period

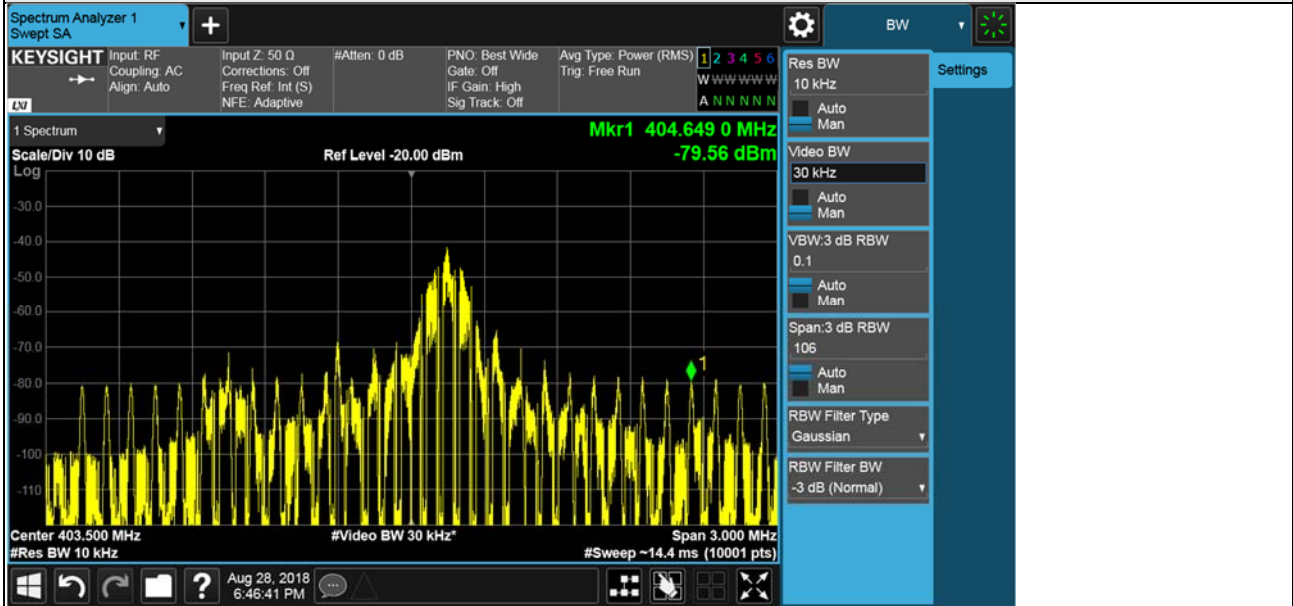

4.6.4 Channel access based on ambient levels relative to the calculated access LBT threshold level

4.6.4.1 Limits

The EUT shall access and transmit on the Least Interfered Channel (LIC) after the CW signal at the frequency f_c has been increased by 9dB from the initial level of 3dB below the calculated access threshold.

4.6.4.2 Test Procedure

1. Configure the test setup as defined in Section 3.2.
2. Setup the blocking band signal generator. Adjust the blocking band power level to 10 dB above the calculated threshold power level and the LIC (Channel 1) to 3 dB above the calculated threshold power level.
3. Start an RF telemetry session. Verify that the session starts on the blocking band open channel (Channel 5)
4. Wait for the telemetry session to end.
5. Setup the on channel signal generator for continuous wave output, 3 dB below the calculated threshold power level, at the center frequency of the open channel in the blocking band.
6. Start an RF telemetry session. Verify that the session starts on the blocking band open channel (Channel 5).
7. Wait for the telemetry session to end.
8. Increase the on channel interferer signal level 9 dB from the following test (6 dB above the calculated threshold power level).
9. Start an RF telemetry session. Verify that the device does not attempt to start a telemetry session due to all channels being above the LBT threshold.

4.6.4.3 Deviation from Test Standard

No deviation.

4.6.4.4 Out-of-operating-region disturbance used

Out-of-operating-region disturbance is generated by using a disturbance source that can generate a sufficient number (approximately $2 \times 3000 / \text{emission bandwidth in kHz}$) of independently-controlled CW signals across the 402 MHz to 405 MHz band to block access to the band except for a notch or notches equal to twice the emission bandwidth of the EUT.

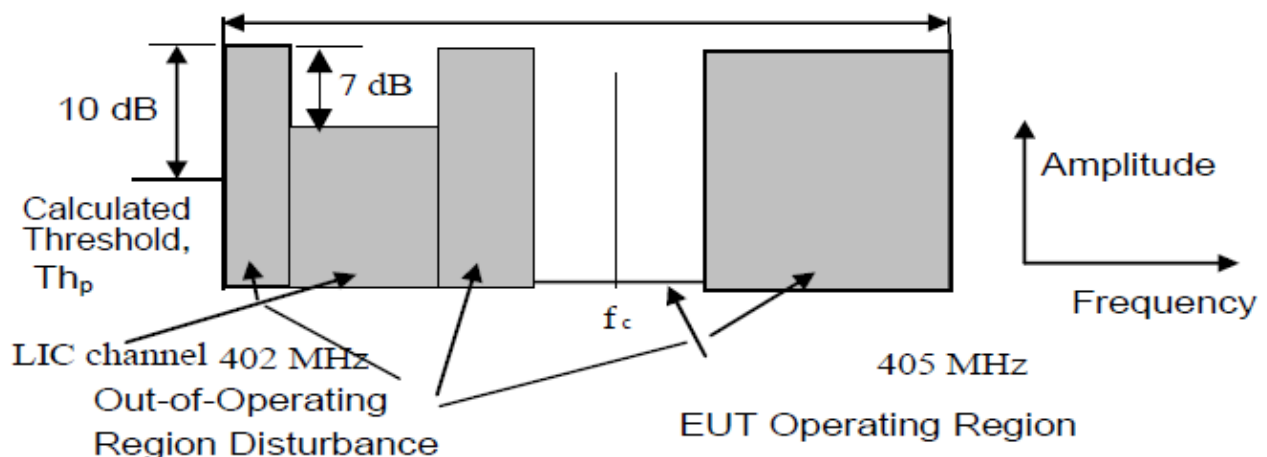

4.6.4.5 Test Results and Graphics

Temperature	Tnom
Voltage	Vnom
Channel	(CH5) 403.65 MHz
Conclusion (EUT transmit on LIC)	Pass

Note: For all measurement, an offset of 20.1dB was used due to the path losses.

Interferer level on $f_c = -3\text{dB}$ below the calculated access threshold

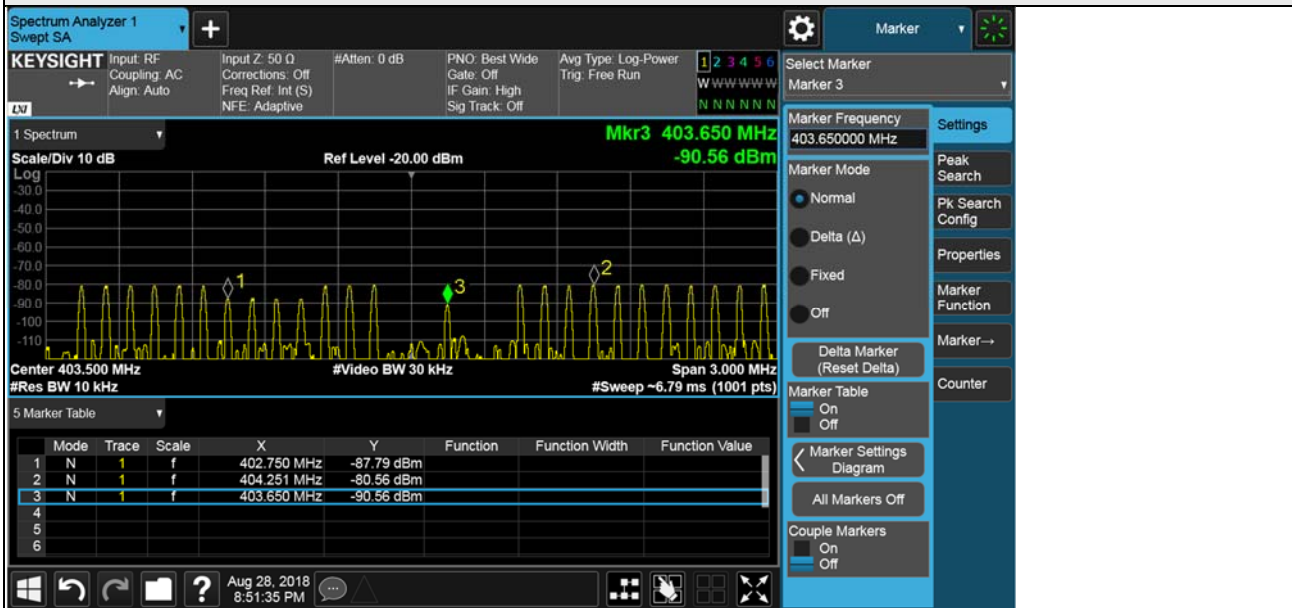

Interferer level on $f_c = -3\text{dB}$ below the calculated access threshold

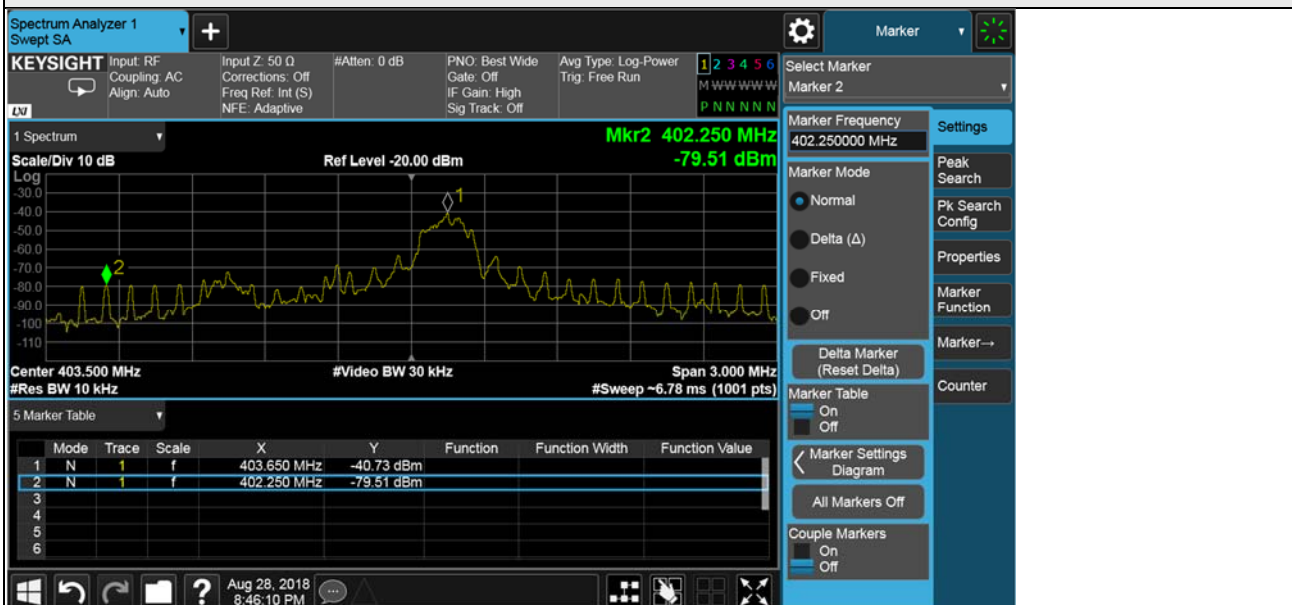

Interferer level on $f_c = 6\text{dB}$ above the calculated access threshold

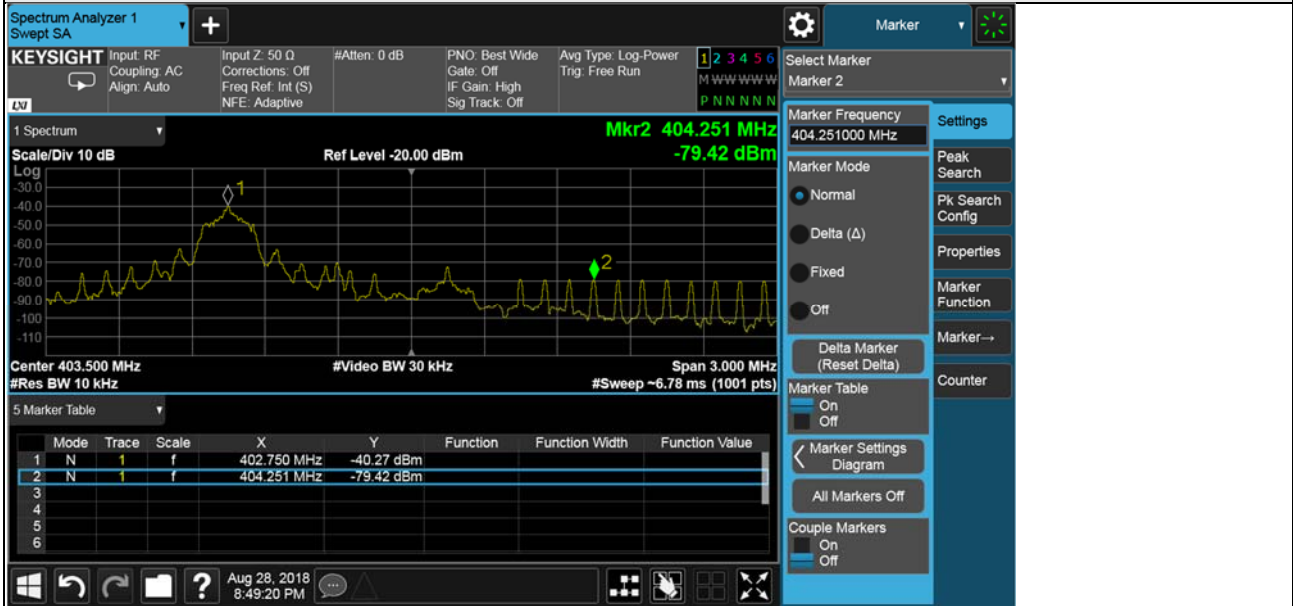

4.6.5 Discontinuation of MICS session if a silent period greater than or equal to 5 seconds occurs

4.6.5.1 Limits

The EUT on the initial LIC channel shall cease transmission in period not exceeding 5 seconds after the ULP-AMI is turned off or blocked and the session should not restart on the initial LIC channel.

4.6.5.2 Test Procedure

1. Configure the test setup as defined in Section 3.2.
2. Setup the blocking band signal generator. Adjust the blocking band power level to 10 dB above the calculated threshold power level.
3. Setup the on channel signal generator for continuous wave output, 3 dB below the calculated threshold power level, at the center frequency of the open channel in the blocking band.
4. Start an RF telemetry session. Verify that the session starts on the blocking band open channel (Channel 5).
5. Set the spectrum analyzer as follows
 - a. Span: zero span
 - b. Frequency: Channel 5 frequency (403.65 MHz)
 - c. Sweep time: 10 seconds
 - d. Sweep: Single
6. Trigger a spectrum analyzer sweep. Adjust the attenuation in the telemetry link in order to stop communications.
7. Record the session stop time on Channel 5. The session stop time is defined as the time period from when the device goes to the continuous TX to when it stops.
8. Reduce the link attenuation to the previous value.
9. Verify that the session starts on the blocking band open channel (Channel 5).

4.6.5.3 Deviation from Test Standard

No deviation.

4.6.5.4 Out-of-operating-region disturbance used

Out-of-operating-region disturbance is generated by using a disturbance source that can generate a sufficient number (approximately $2 \times 3000 / \text{emission bandwidth in kHz}$) of independently-controlled CW signals across the 402 MHz to 405 MHz band to block access to the band except for a notch or notches equal to twice the emission bandwidth of the EUT.

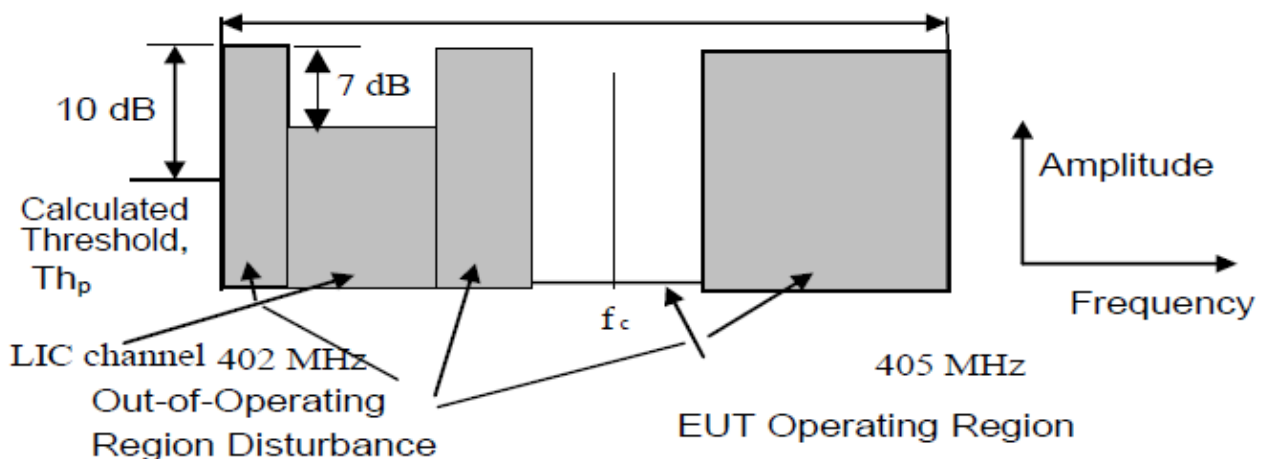

4.6.5.5 Test Results

The EUT transmitter is designed to inherently meet the requirement for an intermittent transmissions as it is equipped with an automatic transmitter shut-off in 2 seconds after the last transmission. Test is not required.

5 Photographs of the Test Configuration

Please refer to the attached file (Test Setup Photo).

Appendix - Information of the Testing Laboratories

We, Bureau Veritas Consumer Products Services (H.K.) Ltd., Taoyuan Branch, were founded in 1988 to provide our best service in EMC, Radio, Telecom and Safety consultation. Our laboratories are FCC recognized accredited test firms and accredited and approved according to ISO/IEC 17025.

If you have any comments, please feel free to contact us at the following:

Lin Kou EMC/RF Lab

Tel: 886-2-26052180

Fax: 886-2-26051924

Hsin Chu EMC/RF/Telecom Lab

Tel: 886-3-6668565

Fax: 886-3-6668323

Hwa Ya EMC/RF/Safety Lab

Tel: 886-3-3183232

Fax: 886-3-3270892

Email: service.adt@tw.bureauveritas.com

Web Site: www.bureauveritas-adt.com

The address and road map of all our labs can be found in our web site also.

--- END ---