

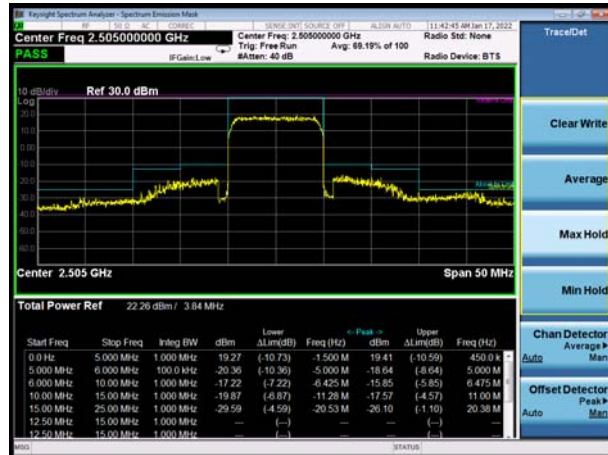

LTE Band 7 QPSK 10MHz CH-Low, 100%RB



LTE Band 7 QPSK 10MHz CH-High, 100%RB



LTE Band 7 QPSK 15MHz CH-Low, 1 RB

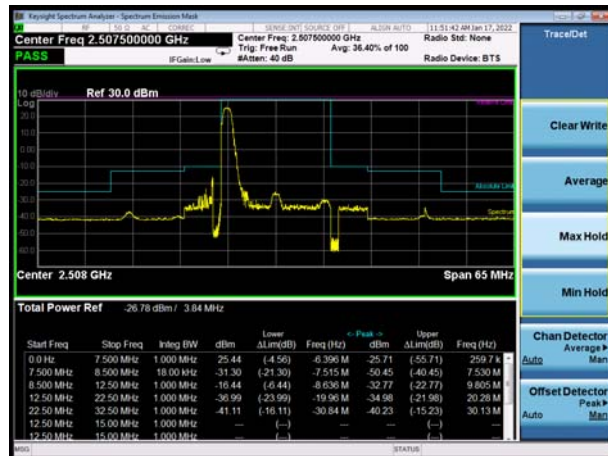

LTE Band 7 QPSK 15MHz CH-High, 1 RB



LTE Band 7 QPSK 15MHz CH-Low, 100%RB



LTE Band 7 QPSK 15MHz CH-High, 100%RB



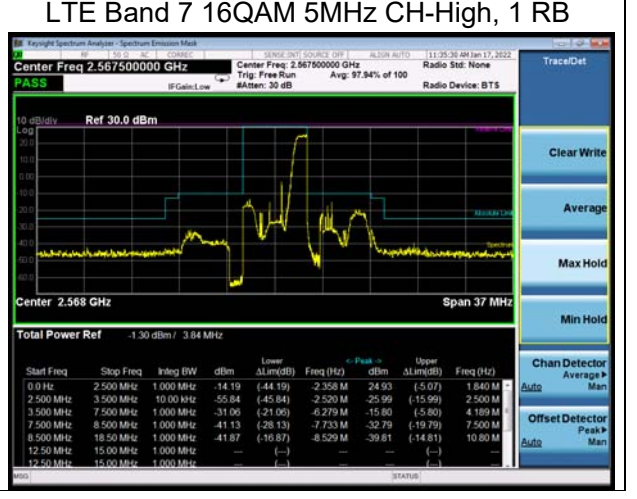
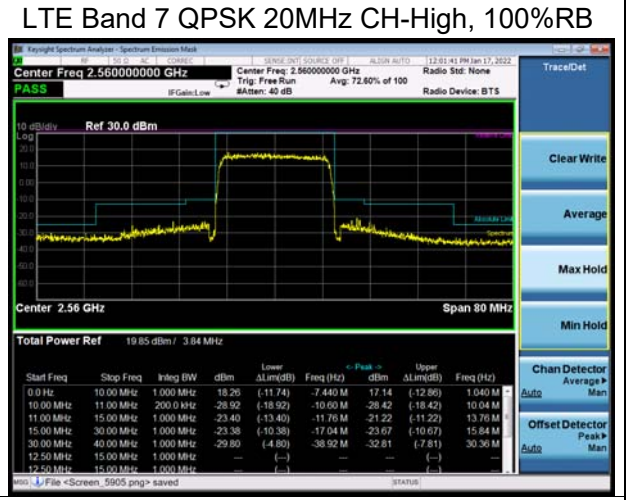
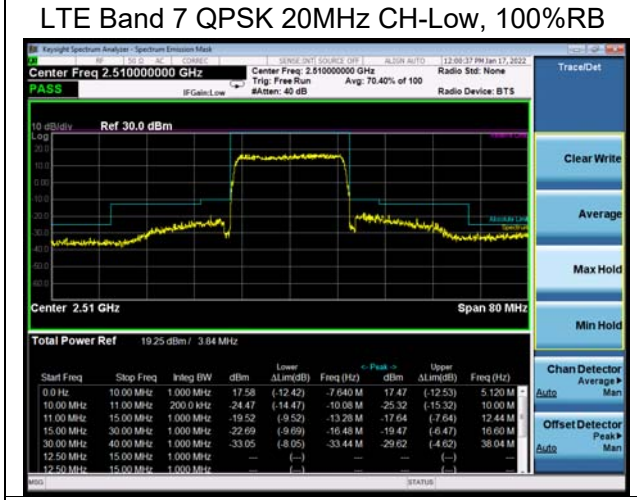
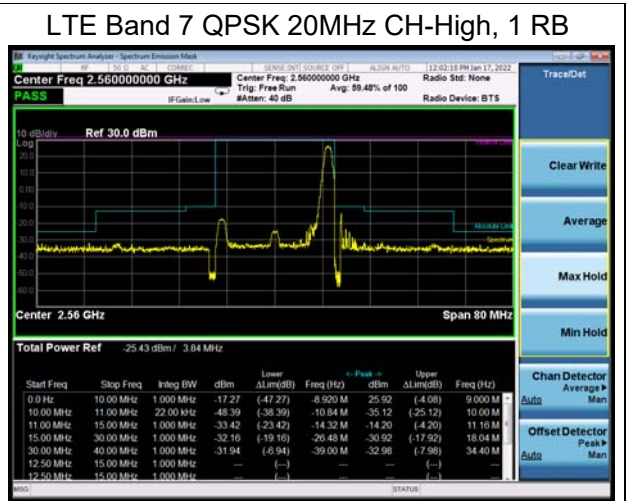
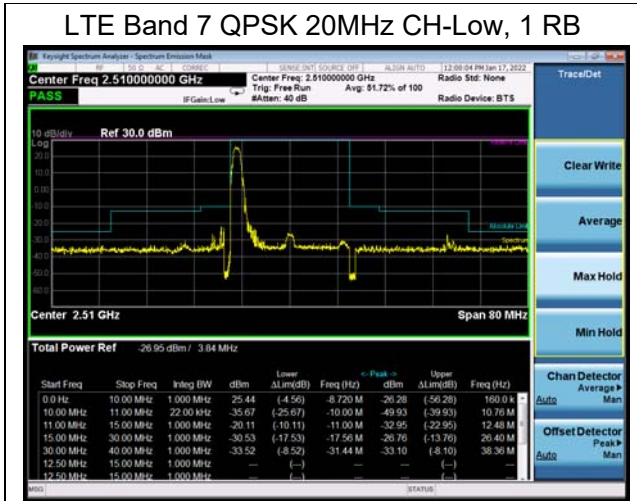



LTE Band 7 16QAM 5MHz CH-Low, 100%RB

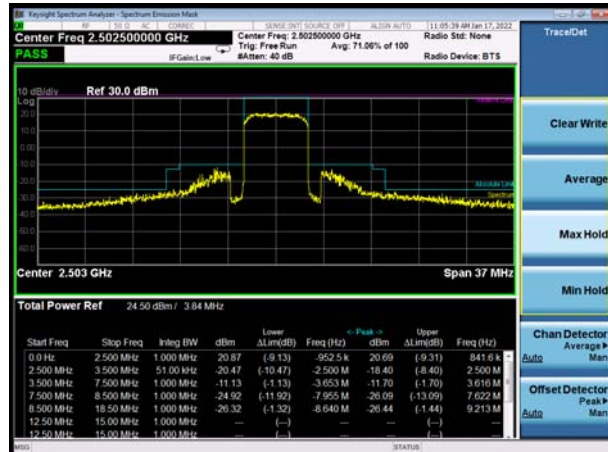

LTE Band 7 16QAM 5MHz CH-High, 100%RB

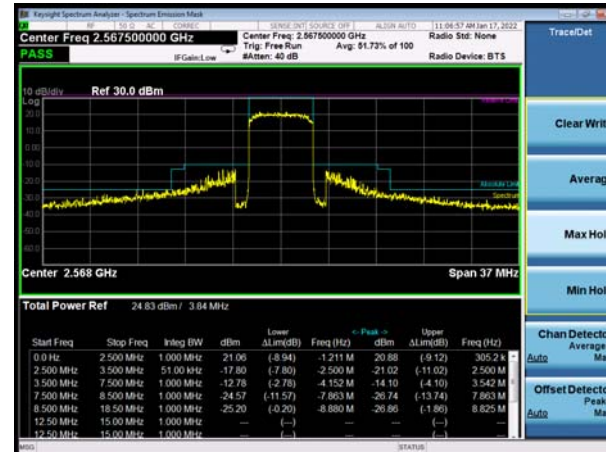

LTE Band 7 16QAM 10MHz CH-Low, 1 RB



LTE Band 7 16QAM 10MHz CH-High, 1 RB

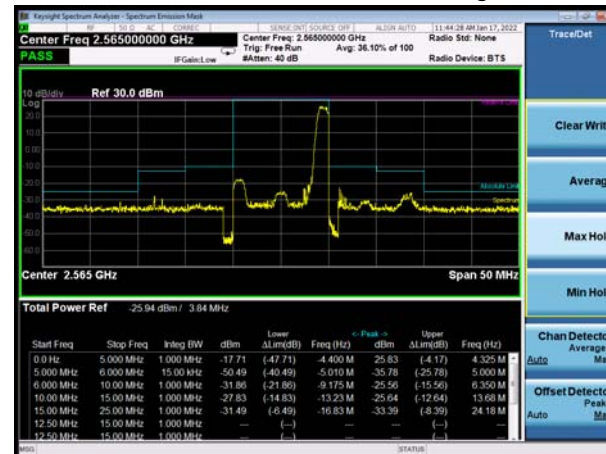

LTE Band 7 16QAM 10MHz CH-Low, 100%RB



LTE Band 7 16QAM 10MHz CH-High, 100%RB





LTE Band 7 16QAM 15MHz CH-Low, 1 RB

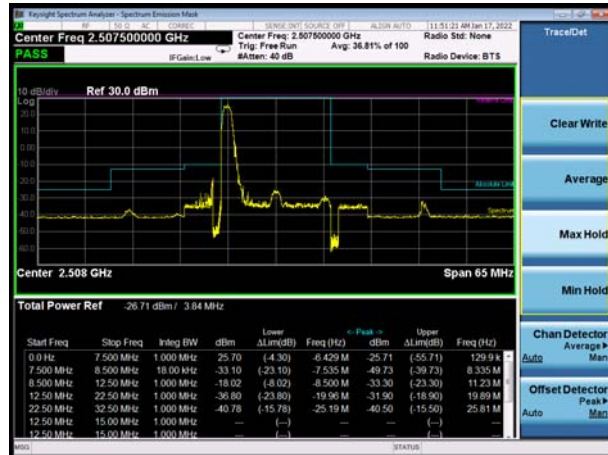

LTE Band 7 16QAM 15MHz CH-High, 1 RB

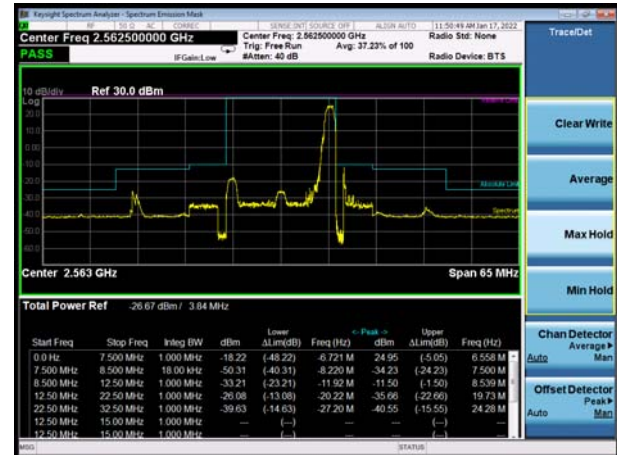

LTE Band 7 16QAM 15MHz CH-Low, 100%RB



LTE Band 7 16QAM 15MHz CH-High, 100%RB



LTE Band 7 16QAM 20MHz CH-Low, 1 RB

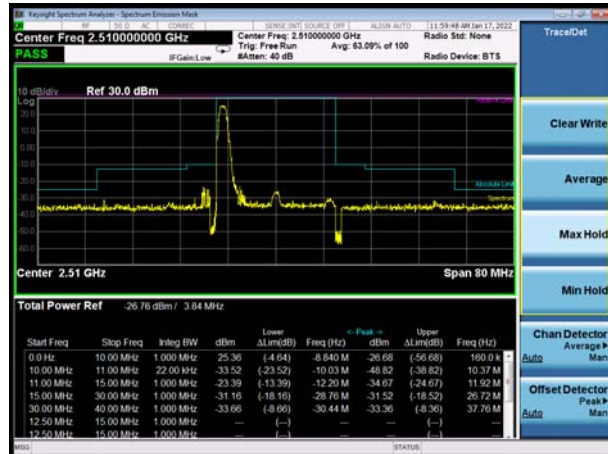

LTE Band 7 16QAM 20MHz CH-High, 1 RB

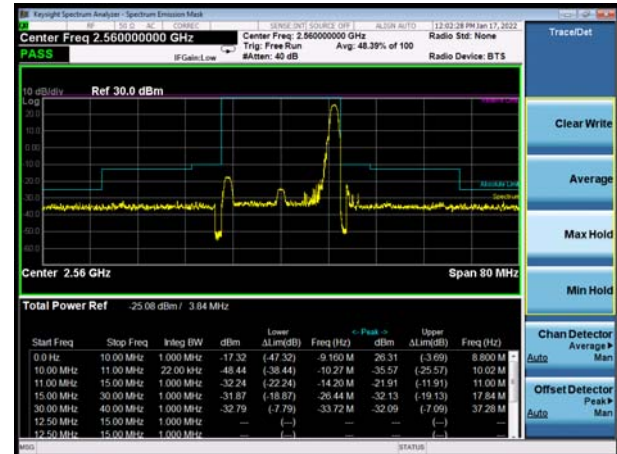



LTE Band 7 16QAM 20MHz CH-Low, 100%RB



LTE Band 7 16QAM 20MHz CH-High, 100%RB

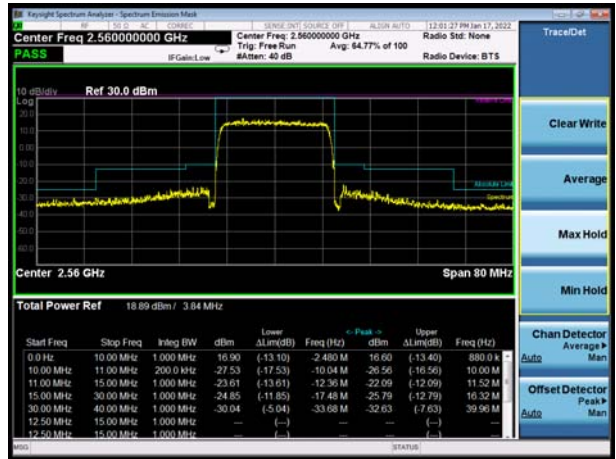

LTE Band 13 QPSK 5MHz CH-Low, 1 RB

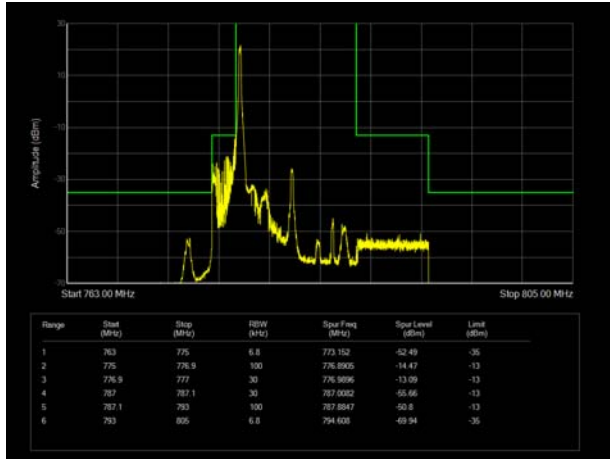

LTE Band 13 QPSK 5MHz CH-High, 1 RB

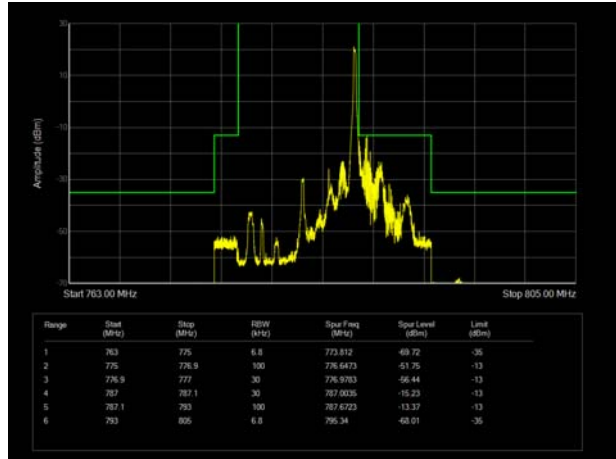

LTE Band 13 QPSK 5MHz CH-Low, 100%RB

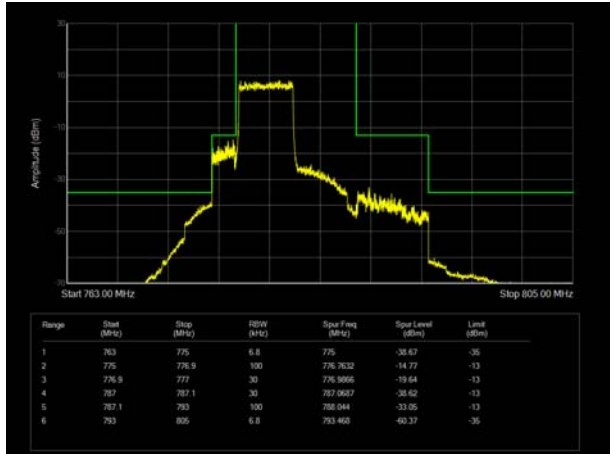

LTE Band 13 QPSK 5MHz CH-High, 100%RB

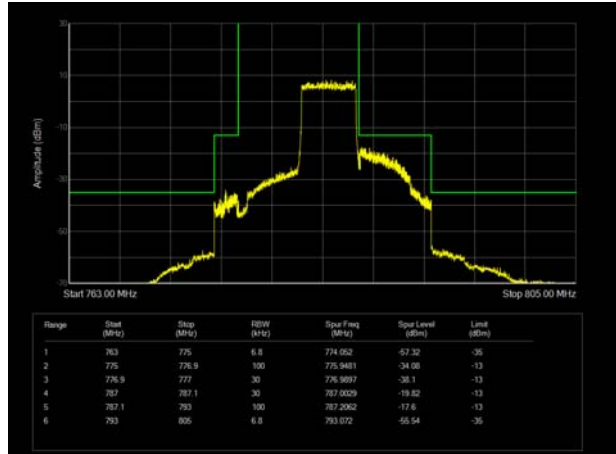



LTE Band 13 QPSK 10MHz CH-Low, 1 RB

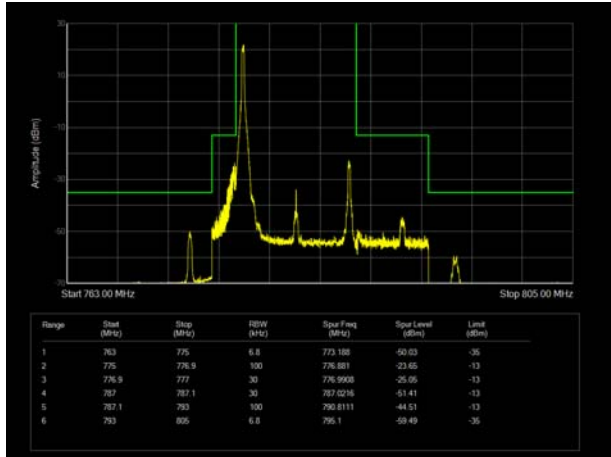

LTE Band 13 QPSK 10MHz CH-High, 1 RB

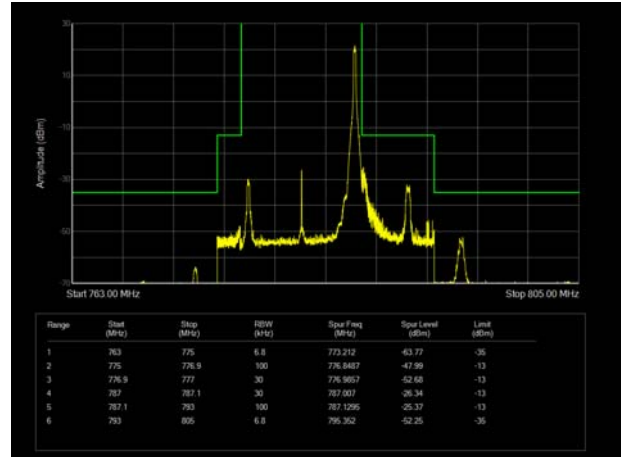

LTE Band 13 QPSK 10MHz CH-Low, 100%RB

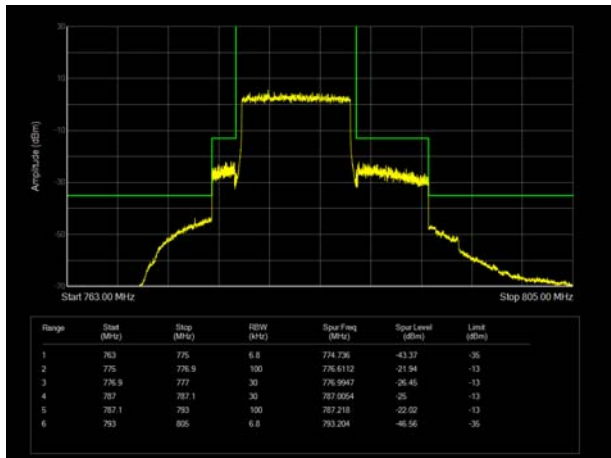

LTE Band 13 QPSK 10MHz CH-High, 100%RB

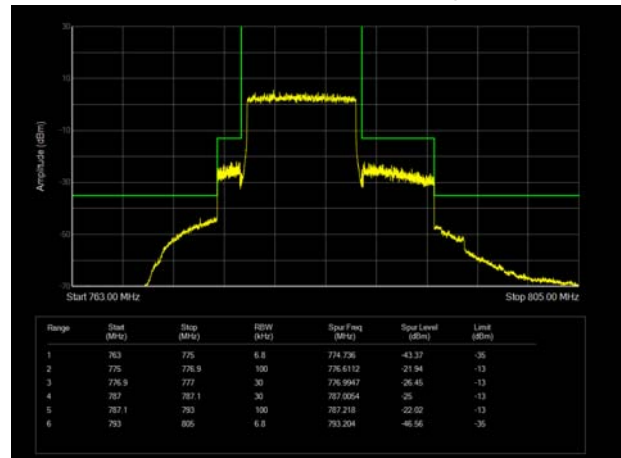

LTE Band 13 16QAM 5MHz CH-Low, 1 RB

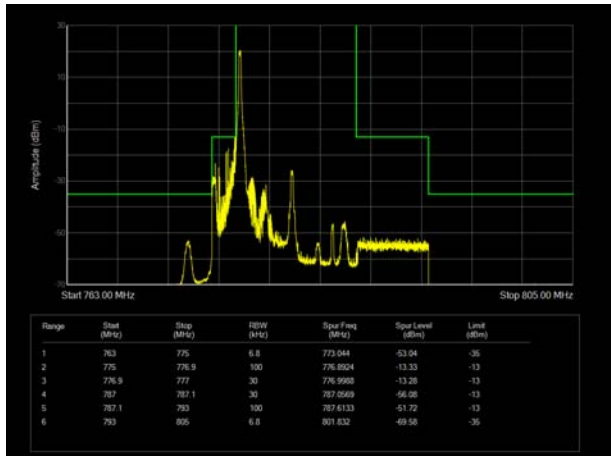

LTE Band 13 16QAM 5MHz CH-High, 1 RB

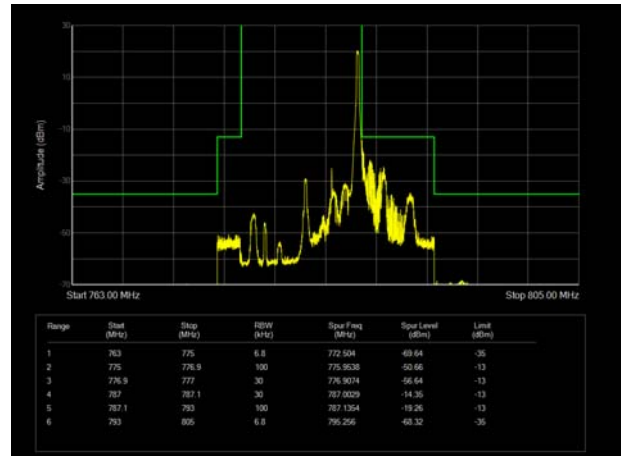



LTE Band 13 16QAM 5MHz CH-Low, 100%RB

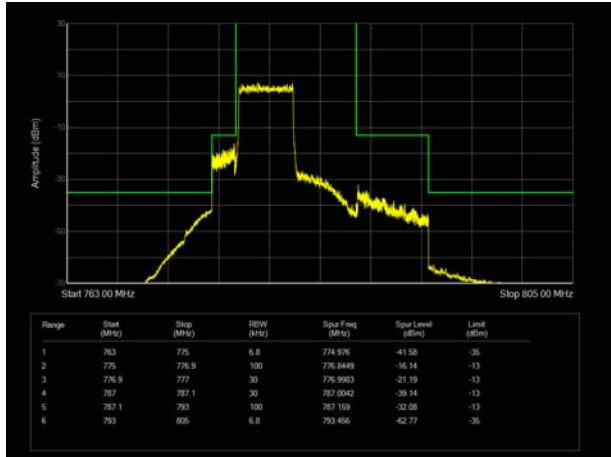

LTE Band 13 16QAM 5MHz CH-High, 100%RB

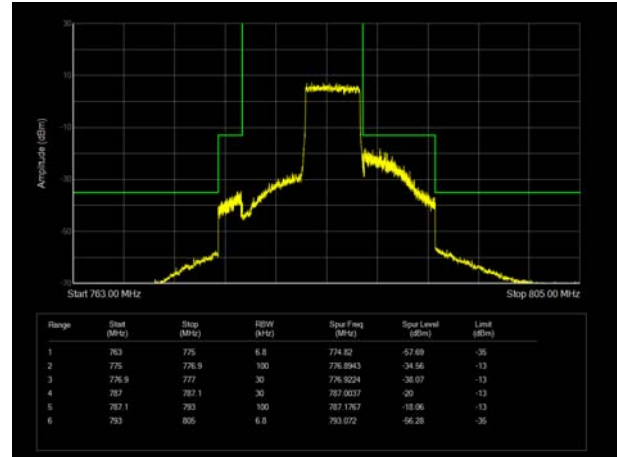

LTE Band 13 16QAM 10MHz CH-Low, 1 RB

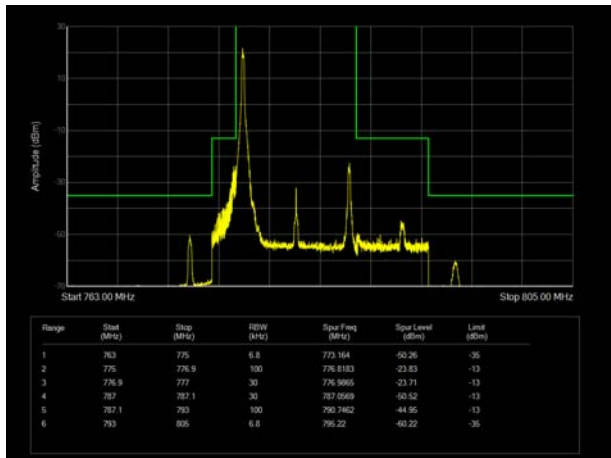

LTE Band 13 16QAM 10MHz CH-High, 1 RB

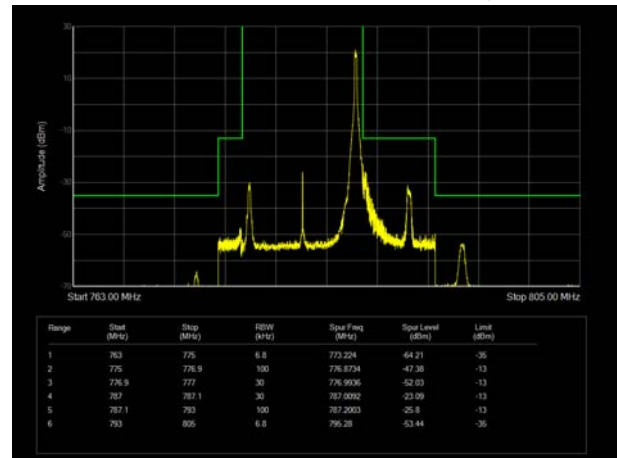

LTE Band 13 16QAM 10MHz CH-Low, 100%RB

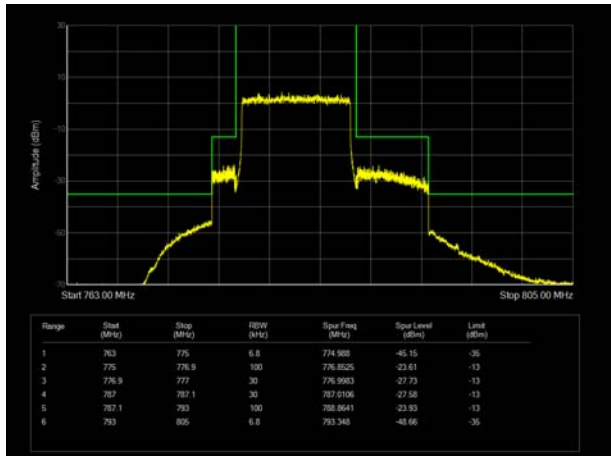

LTE Band 13 16QAM 10MHz CH-High, 100%RB

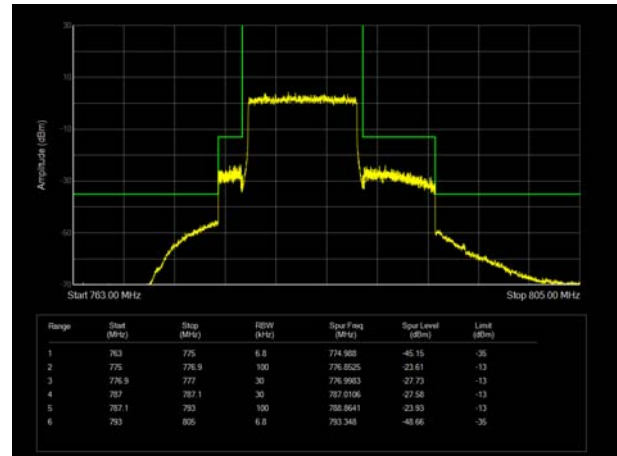



LTE Band 38 QPSK 5MHz CH-Low, 1 RB

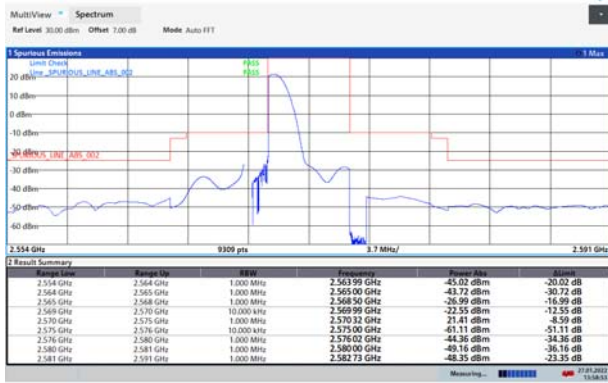

13:58:13 27.01.2022

LTE Band 38 QPSK 5MHz CH-High, 1 RB

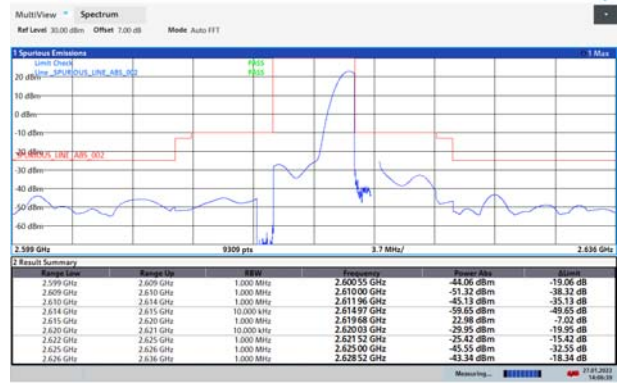

14:04:39 27.01.2022

LTE Band 38 QPSK 5MHz CH-Low, 100%RB

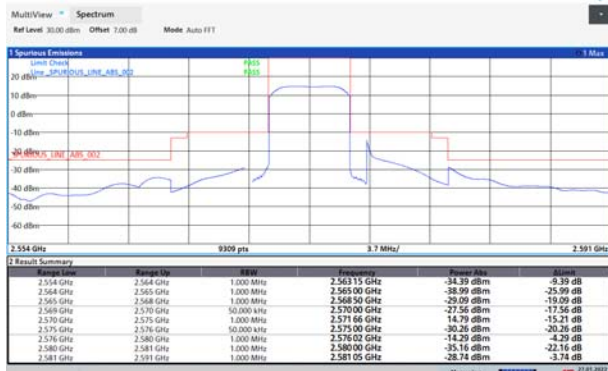

14:01:19 27.01.2022

LTE Band 38 QPSK 5MHz CH-High, 100%RB



14:04:33 27.01.2022

LTE Band 38 QPSK 10MHz CH-Low, 1 RB

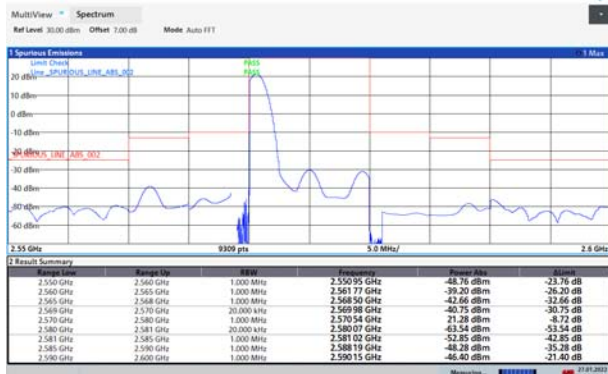

14:27:30 27.01.2022

LTE Band 38 QPSK 10MHz CH-High, 1 RB

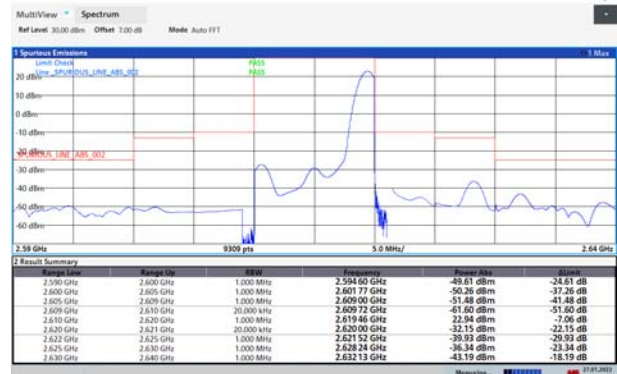

14:24:04 27.01.2022



LTE Band 38 QPSK 10MHz CH-Low, 100%RB

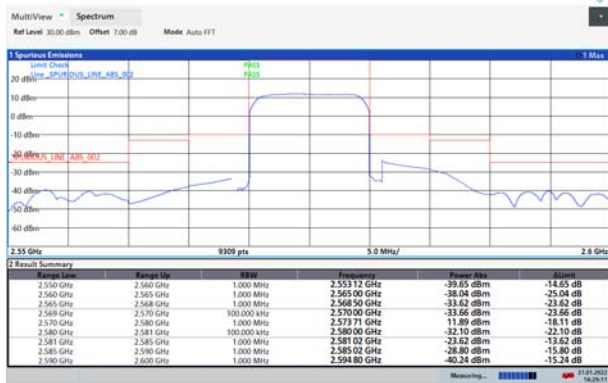

14:29:11 27.01.2022

LTE Band 38 QPSK 10MHz CH-High, 100%RB

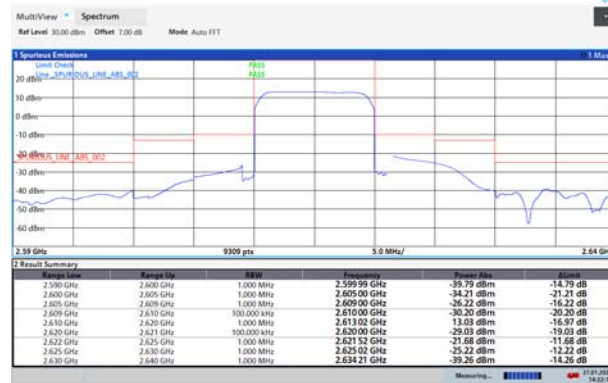

14:22:14 27.01.2022

LTE Band 38 QPSK 15MHz CH-Low, 1 RB

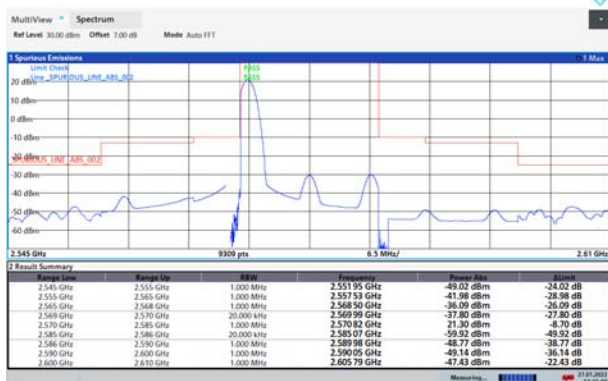

14:34:00 27.01.2022

LTE Band 38 QPSK 15MHz CH-High, 1 RB

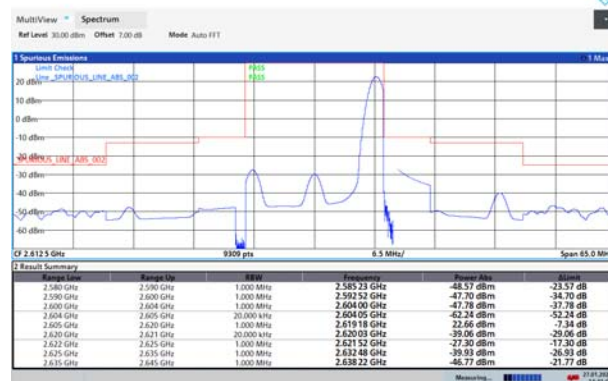

14:41:03 27.01.2022

LTE Band 38 QPSK 15MHz CH-Low, 100%RB

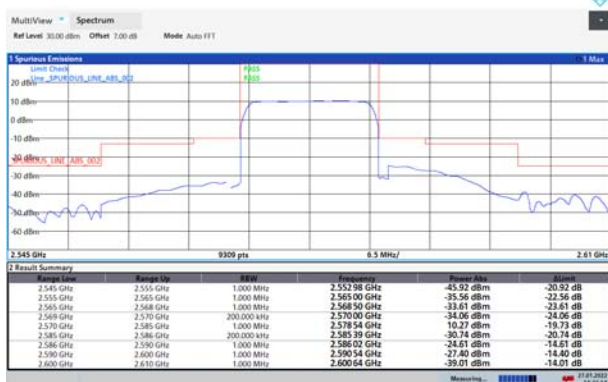

14:33:54 27.01.2022

LTE Band 38 QPSK 15MHz CH-High, 100%RB

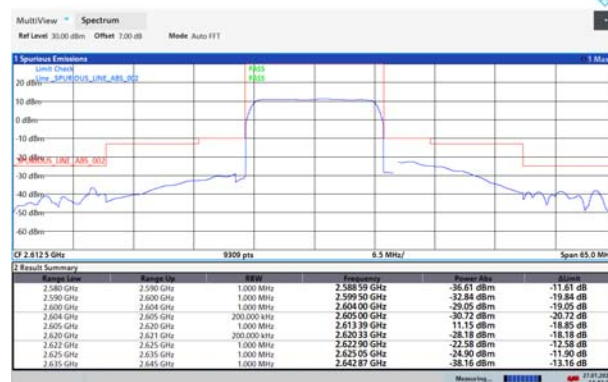

14:42:40 27.01.2022



LTE Band 38 QPSK 20MHz CH-Low, 1 RB

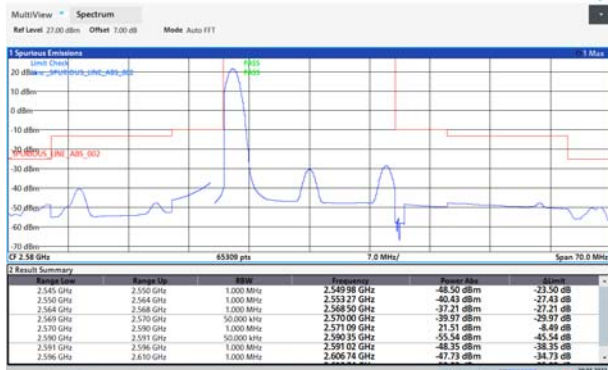

11:28:25 30.01.2022

LTE Band 38 QPSK 20MHz CH-High, 1 RB

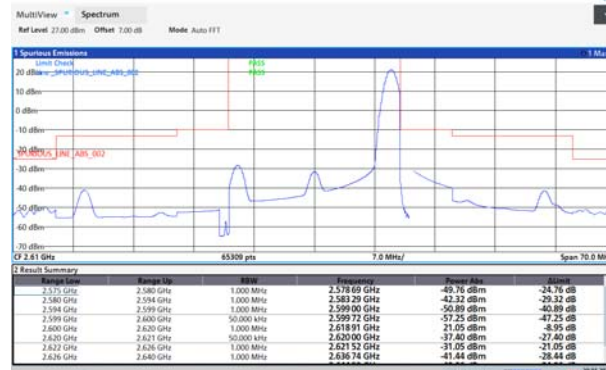

11:34:08 30.01.2022

LTE Band 38 QPSK 20MHz CH-Low, 100%RB



11:30:05 30.01.2022

LTE Band 38 QPSK 20MHz CH-High, 100%RB



11:30:09 30.01.2022

LTE Band 38 16QAM 5MHz CH-Low, 1 RB

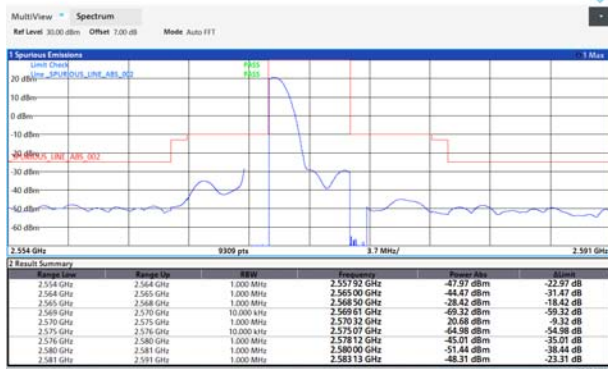

13:59:26 27.01.2022

LTE Band 38 16QAM 5MHz CH-High, 1 RB

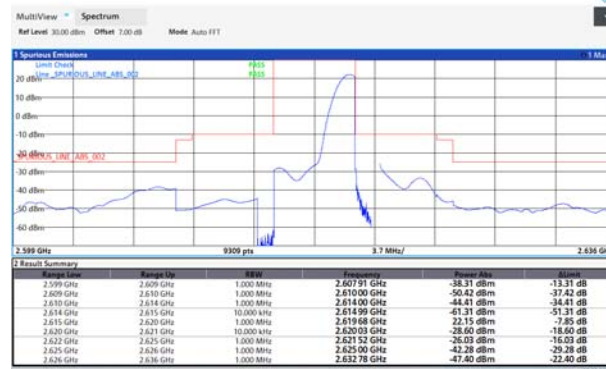

14:04:04 27.01.2022



LTE Band 38 16QAM 5MHz CH-Low, 100%RB

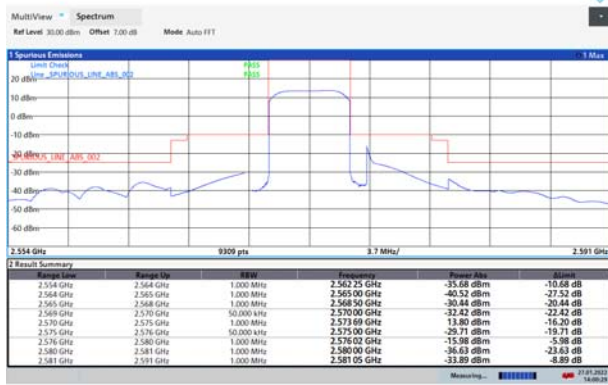

14:00:29 27.01.2022

LTE Band 38 16QAM 5MHz CH-High, 100%RB

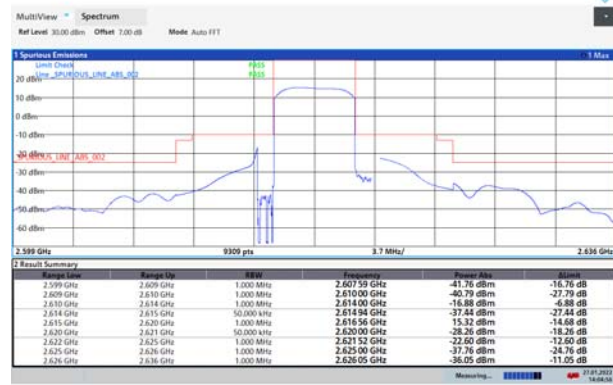

14:04:17 27.01.2022

LTE Band 38 16QAM 10MHz CH-Low, 1 RB

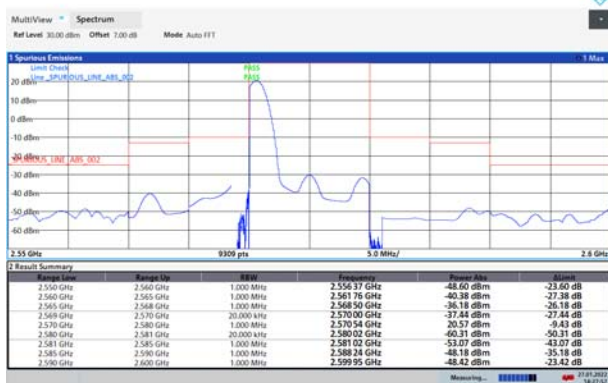

14:27:17 27.01.2022

LTE Band 38 16QAM 10MHz CH-High, 1 RB

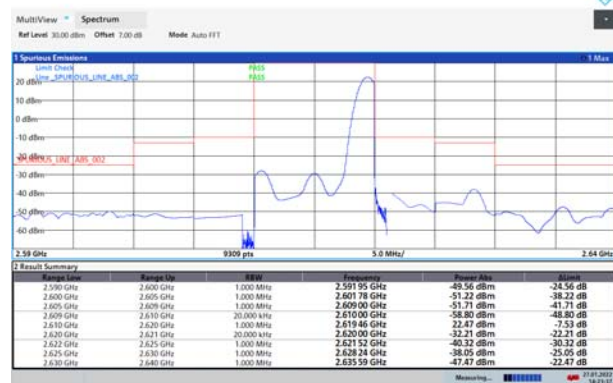

14:23:37 27.01.2022

LTE Band 38 16QAM 10MHz CH-Low, 100%RB

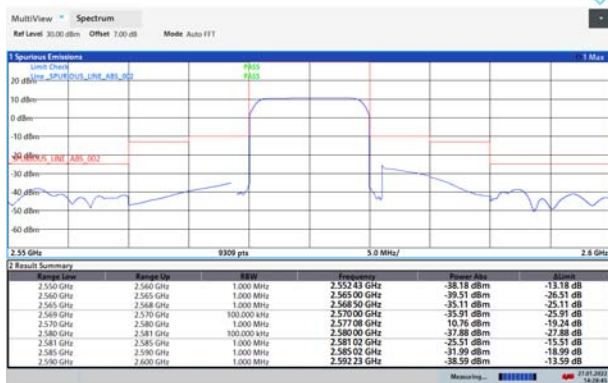

14:28:48 27.01.2022

LTE Band 38 16QAM 10MHz CH-High, 100%RB

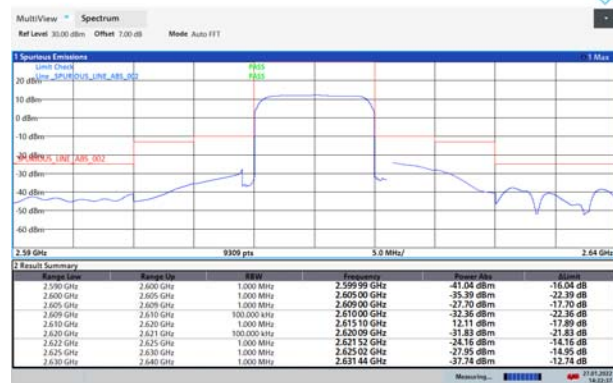

14:22:37 27.01.2022



LTE Band 38 16QAM 15MHz CH-Low, 1 RB

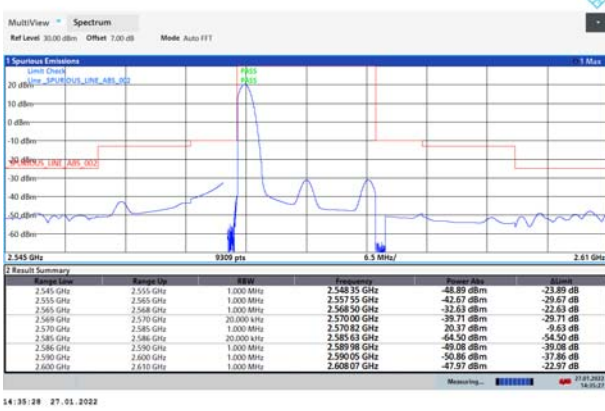

LTE Band 38 16QAM 15MHz CH-High, 1 RB

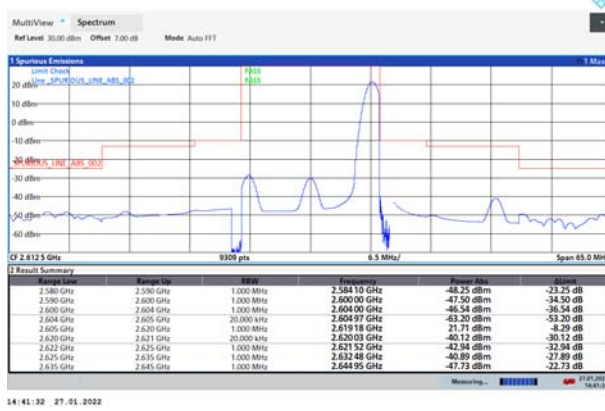

LTE Band 38 16QAM 15MHz CH-Low, 100%RB

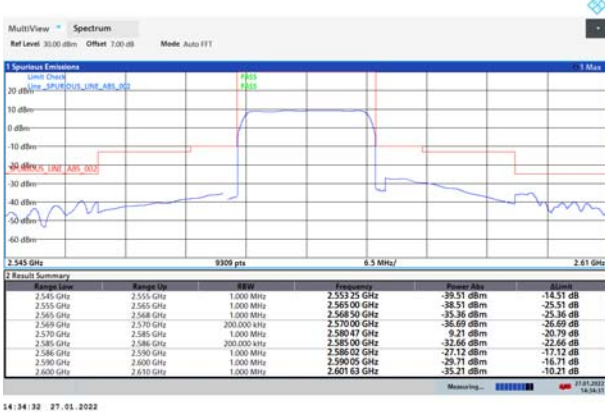

LTE Band 38 16QAM 15MHz CH-High, 100%RB

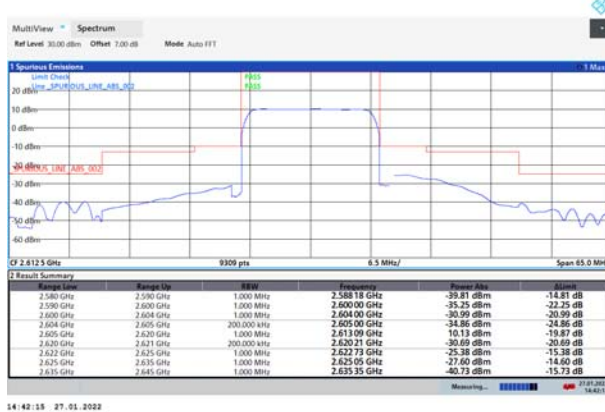

LTE Band 38 16QAM 20MHz CH-Low, 1 RB

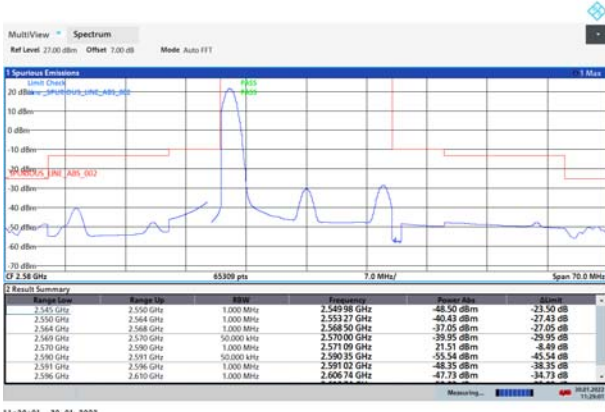

LTE Band 38 16QAM 20MHz CH-High, 1 RB

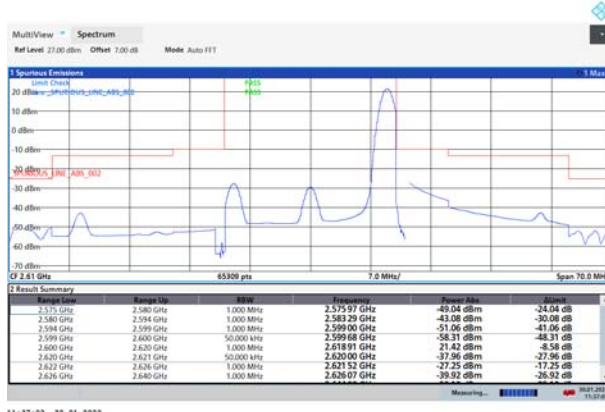



LTE Band 38 16QAM 20MHz CH-Low, 100% RB

LTE Band 38 16QAM 20MHz CH-High, 100% RB

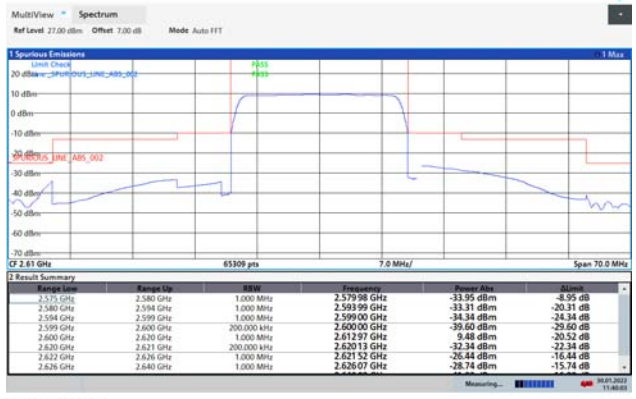
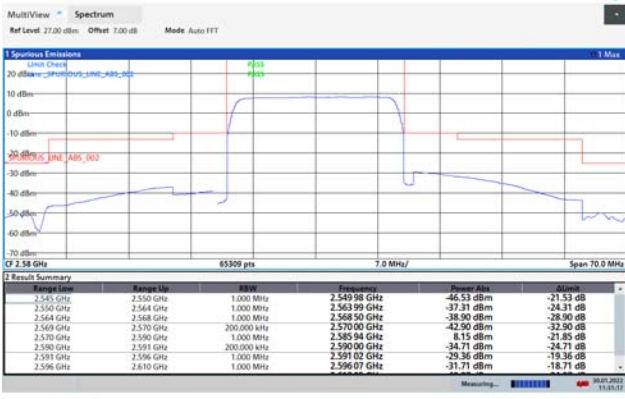

LTE Band 66 QPSK 1.4MHz CH-Low, 1 RB



LTE Band 66 QPSK 1.4MHz CH-High, 1 RB

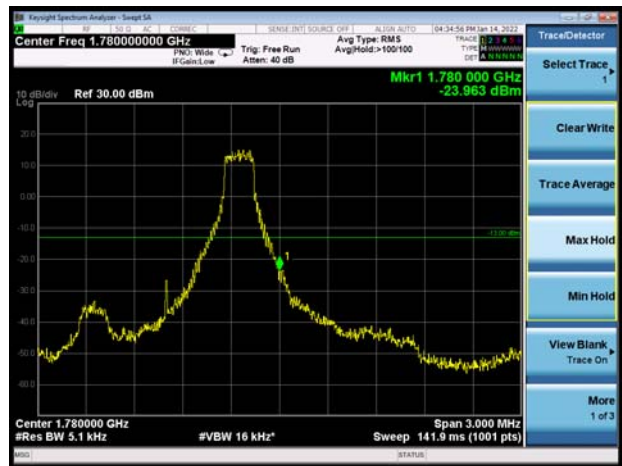

LTE Band 66 QPSK 1.4MHz CH-Low, 100%RB

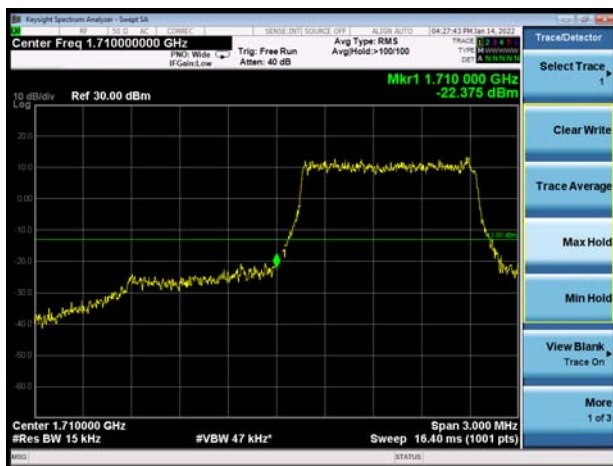

LTE Band 66 QPSK 1.4MHz CH-High, 100%RB

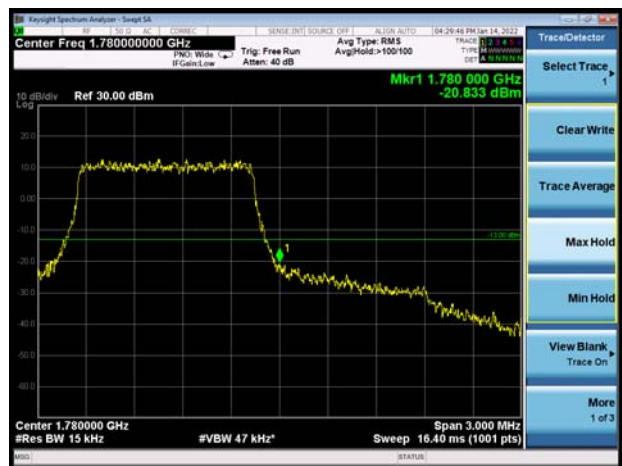

LTE Band 66 QPSK 3MHz CH-Low, 1 RB



LTE Band 66 QPSK 3MHz CH-High, 1 RB

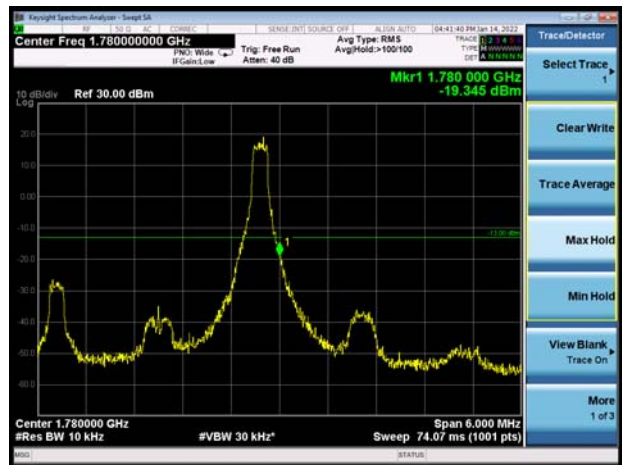



LTE Band 66 QPSK 3MHz CH-Low, 100%RB

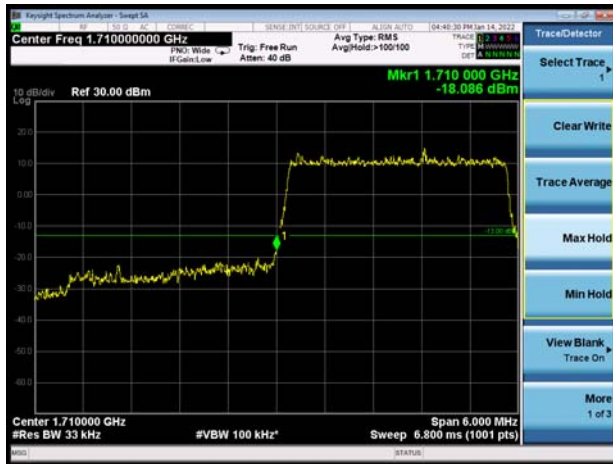

LTE Band 66 QPSK 3MHz CH-High, 100%RB

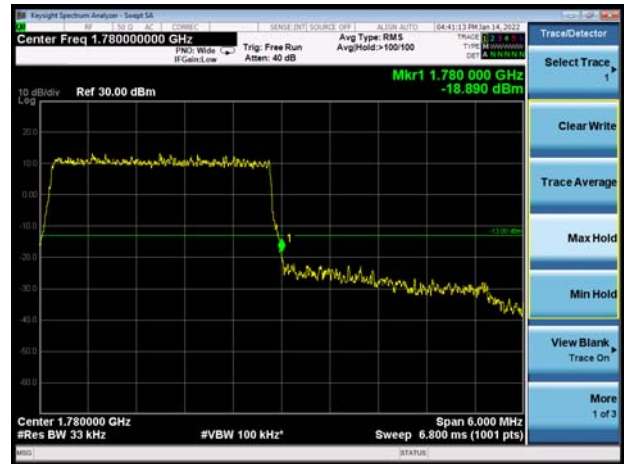

LTE Band 66 QPSK 5MHz CH-Low, 1 RB

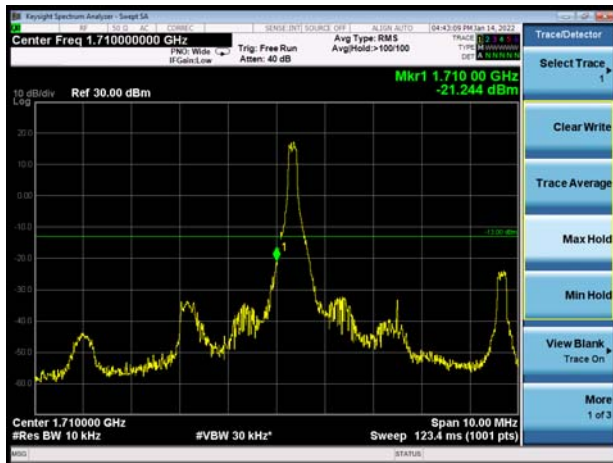

LTE Band 66 QPSK 5MHz CH-High, 1 RB



LTE Band 66 QPSK 5MHz CH-Low, 100%RB

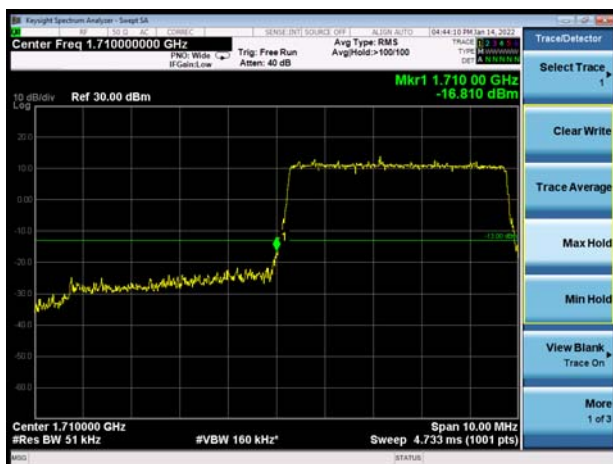

LTE Band 66 QPSK 5MHz CH-High, 100%RB

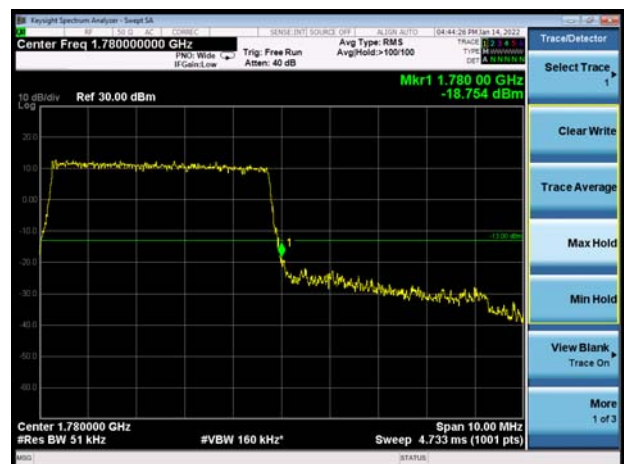



LTE Band 66 QPSK 10MHz CH-Low, 1 RB

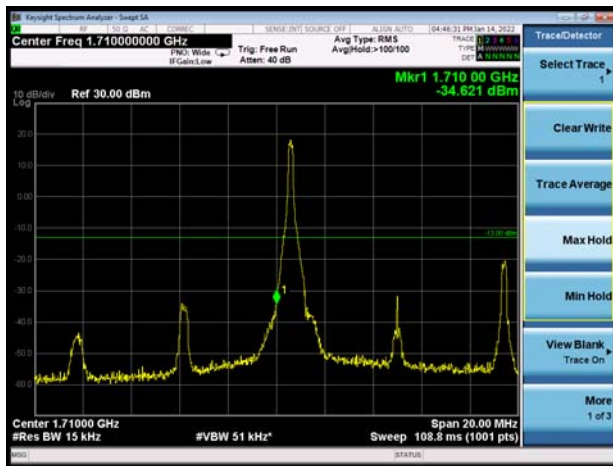

LTE Band 66 QPSK 10MHz CH-High, 1 RB

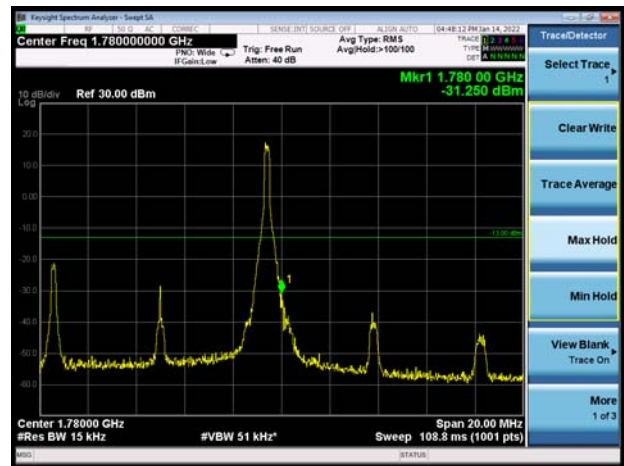

LTE Band 66 QPSK 10MHz CH-Low, 100%RB

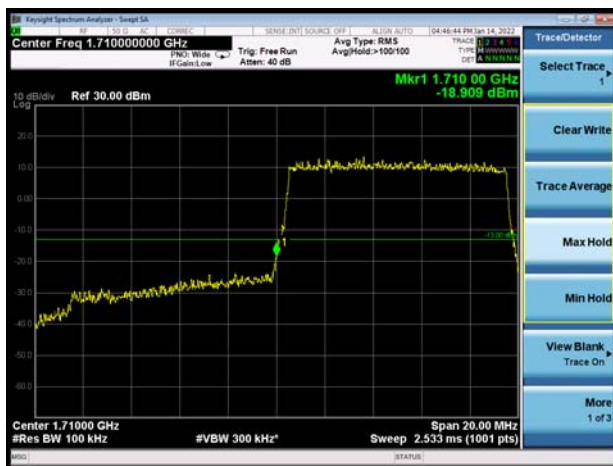

LTE Band 66 QPSK 10MHz CH-High, 100%RB

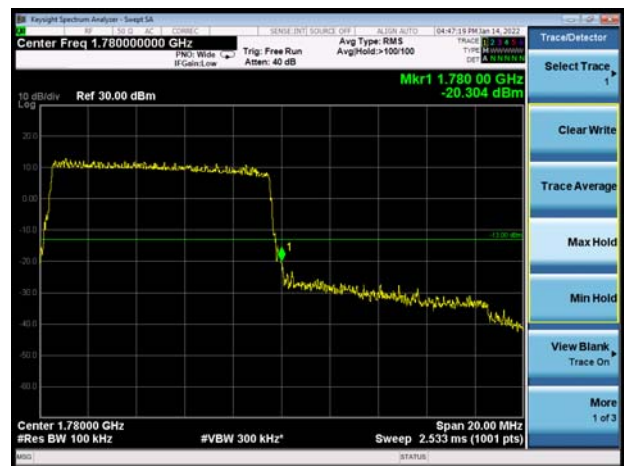

LTE Band 66 QPSK 15MHz CH-Low, 1 RB

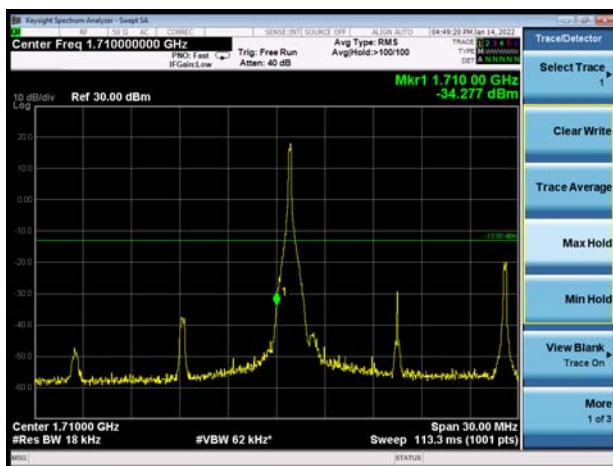

LTE Band 66 QPSK 15MHz CH-High, 1 RB

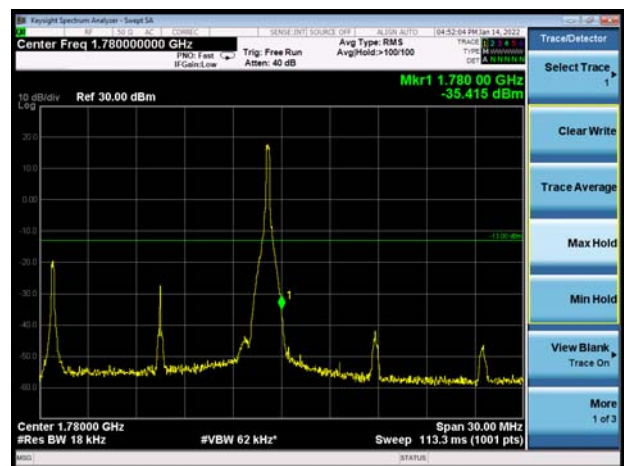



LTE Band 66 QPSK 15MHz CH-Low, 100%RB



LTE Band 66 QPSK 15MHz CH-High, 100%RB



LTE Band 66 QPSK 20MHz CH-Low, 1 RB

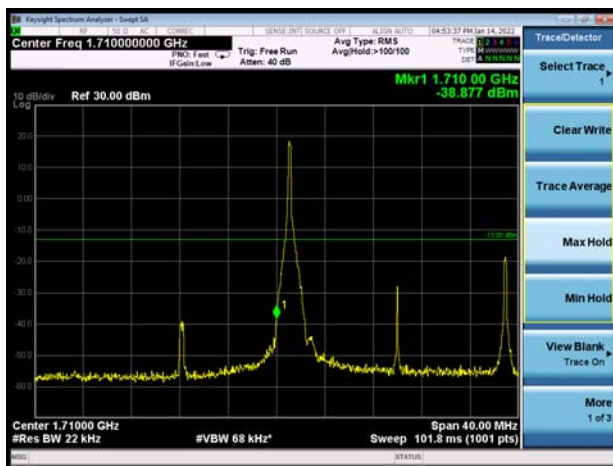

LTE Band 66 QPSK 20MHz CH-High, 1 RB

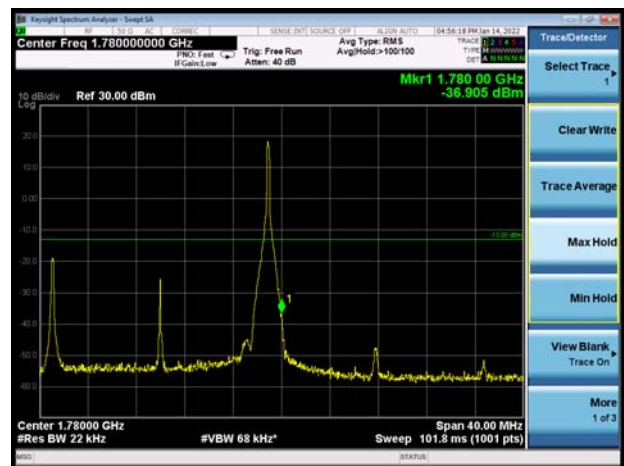

LTE Band 66 QPSK 20MHz CH-Low, 100%RB

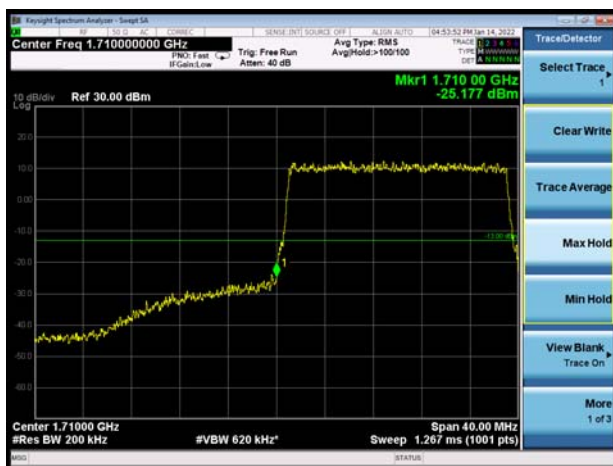

LTE Band 66 QPSK 20MHz CH-High, 100%RB

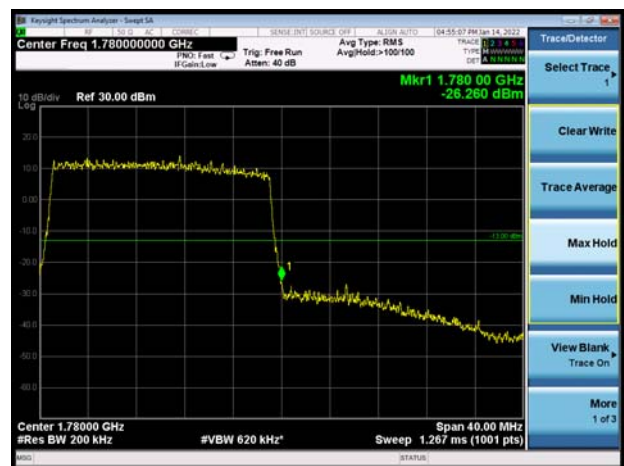



LTE Band 66 16QAM 1.4MHz CH-Low, 1 RB

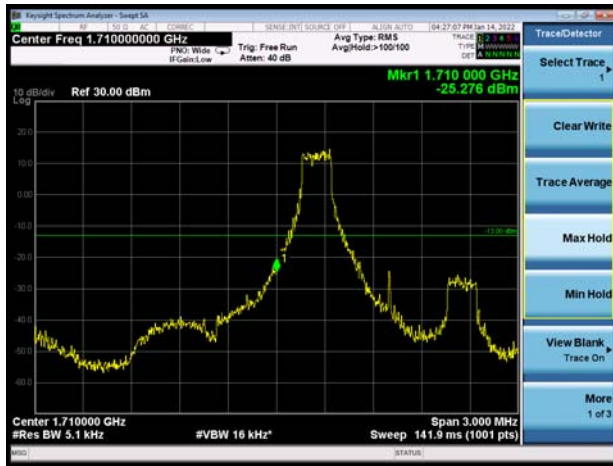

LTE Band 66 16QAM 1.4MHz CH-High, 1 RB

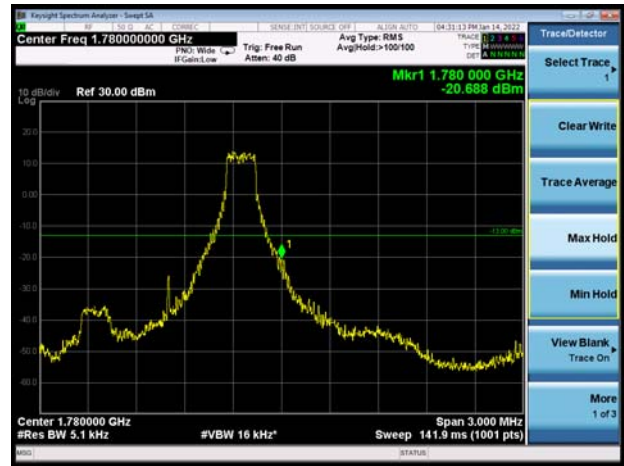

LTE Band 66 16QAM 1.4MHz CH-Low, 100%RB



LTE Band 66 16QAM 1.4MHz CH-High, 100%RB

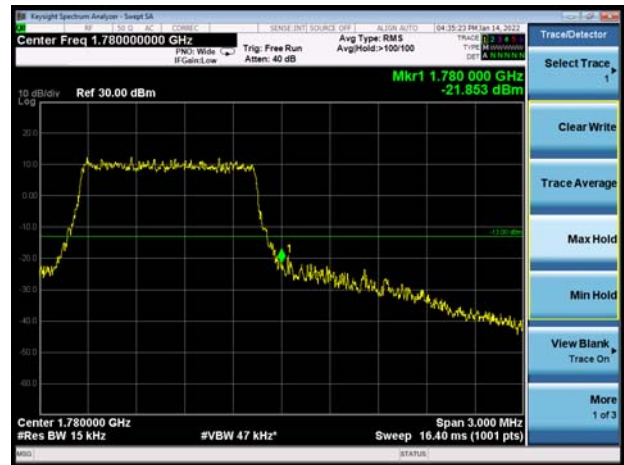

LTE Band 66 16QAM 3MHz CH-Low, 1 RB



LTE Band 66 16QAM 3MHz CH-High, 1 RB

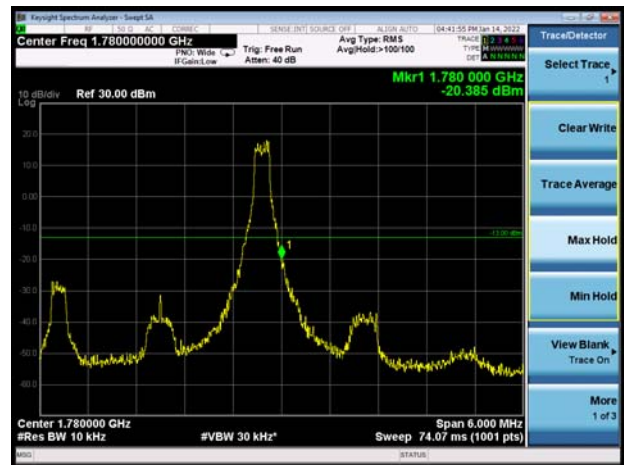



LTE Band 66 16QAM 3MHz CH-Low, 100%RB

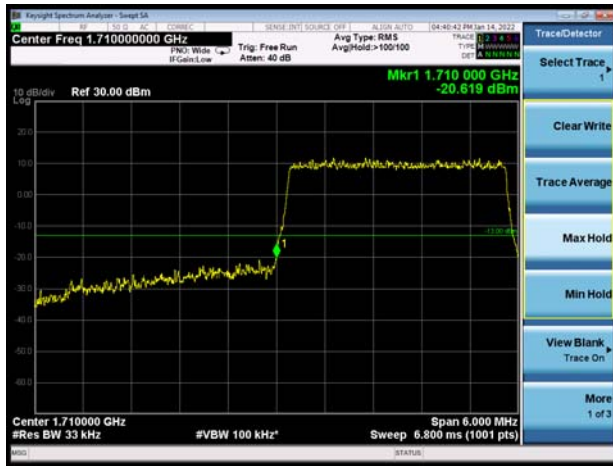

LTE Band 66 16QAM 3MHz CH-High, 100%RB



LTE Band 66 16QAM 5MHz CH-Low, 1 RB



LTE Band 66 16QAM 5MHz CH-High, 1 RB

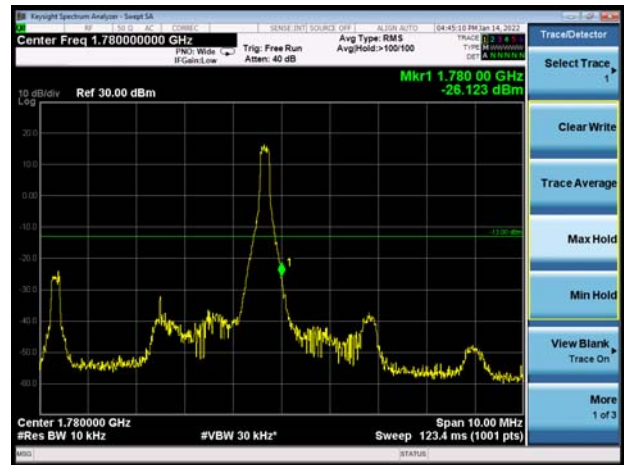

LTE Band 66 16QAM 5MHz CH-Low, 100%RB

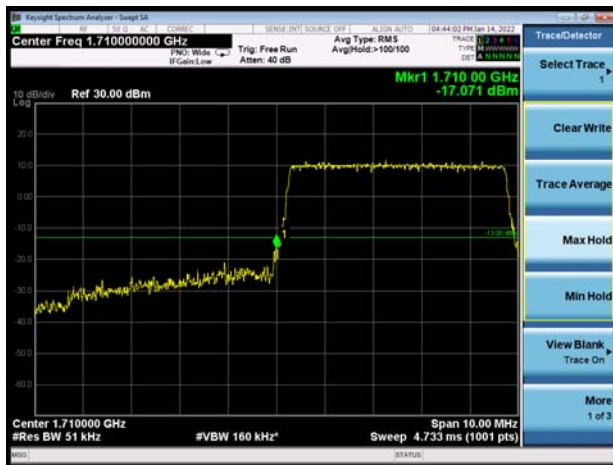

LTE Band 66 16QAM 5MHz CH-High, 100%RB





LTE Band 66 16QAM 10MHz CH-Low, 1 RB

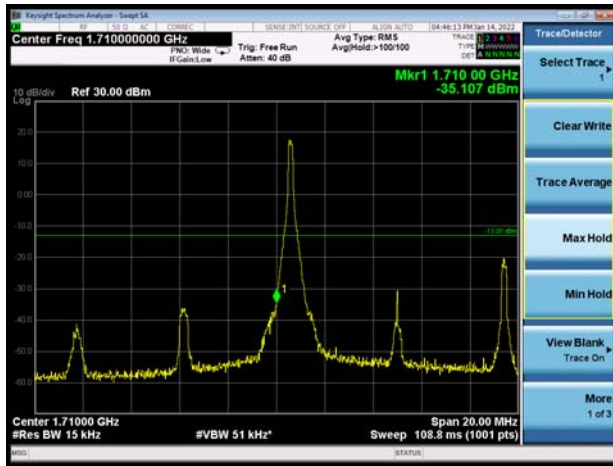

LTE Band 66 16QAM 10MHz CH-High, 1 RB

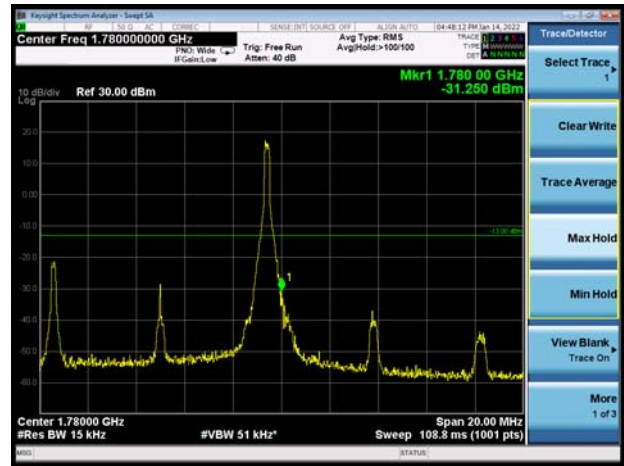

LTE Band 66 16QAM 10MHz CH-Low, 100%RB

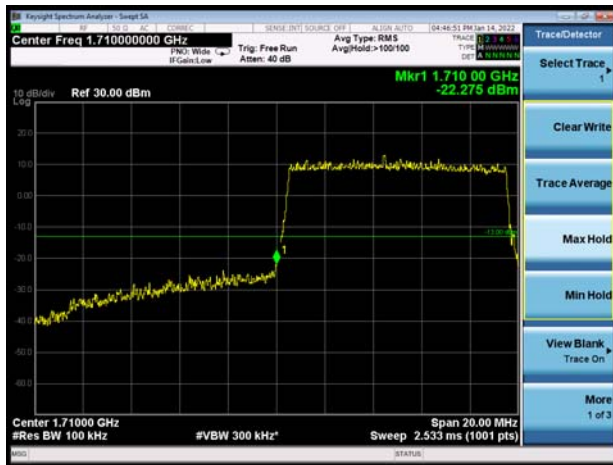

LTE Band 66 16QAM 10MHz CH-High, 100%RB



LTE Band 66 16QAM 15MHz CH-Low, 1 RB

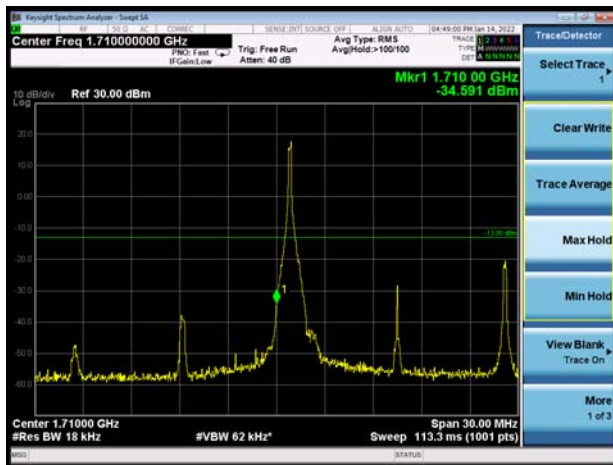

LTE Band 66 16QAM 15MHz CH-High, 1 RB

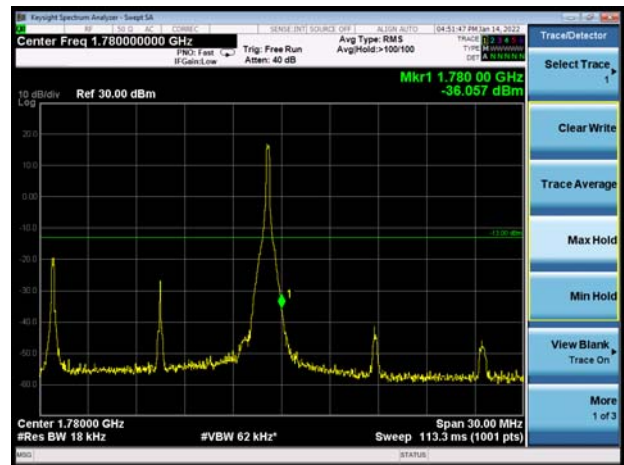



LTE Band 66 16QAM 15MHz CH-Low, 100%RB



LTE Band 66 16QAM 15MHz CH-High, 100%RB



LTE Band 66 16QAM 20MHz CH-Low, 1 RB

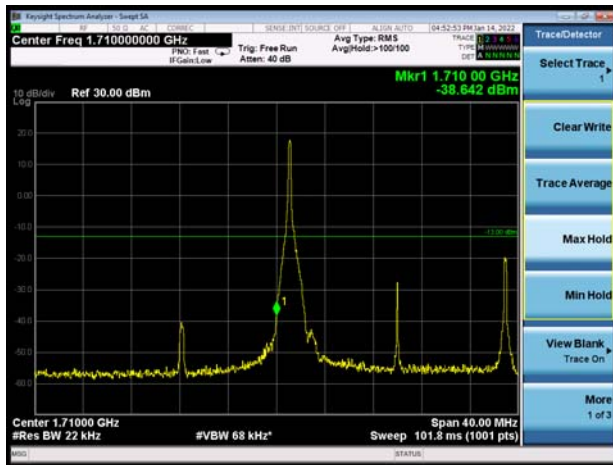

LTE Band 66 16QAM 20MHz CH-High, 1 RB

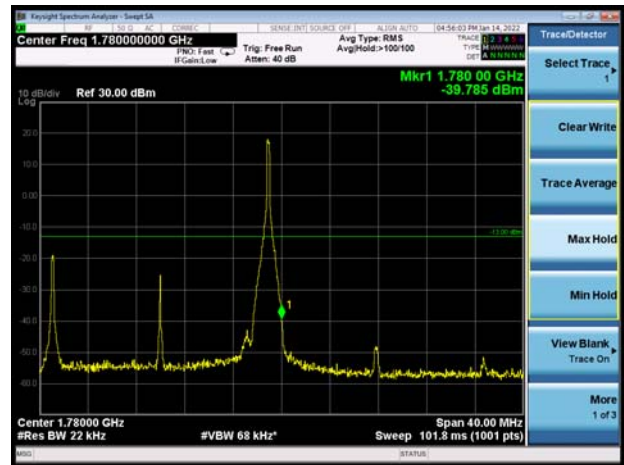

LTE Band 66 16QAM 20MHz CH-Low, 100%RB



LTE Band 66 16QAM 20MHz CH-High, 100%RB



5.4 Peak-to-Average Power Ratio (PAPR)

Ambient condition

Temperature	Relative humidity	Pressure
23°C ~25°C	45%~50%	101.5kPa

Methods of Measurement

Measure the total peak power and record as Ppk. And measure the total average power and record as PAvg. Both the peak and average power levels must be expressed in the same logarithmic units (e.g., dBm). Determine the PAPR from:

$$PAPR (dB) = Ppk (dBm) - PAvg (dBm).$$

Test Setup

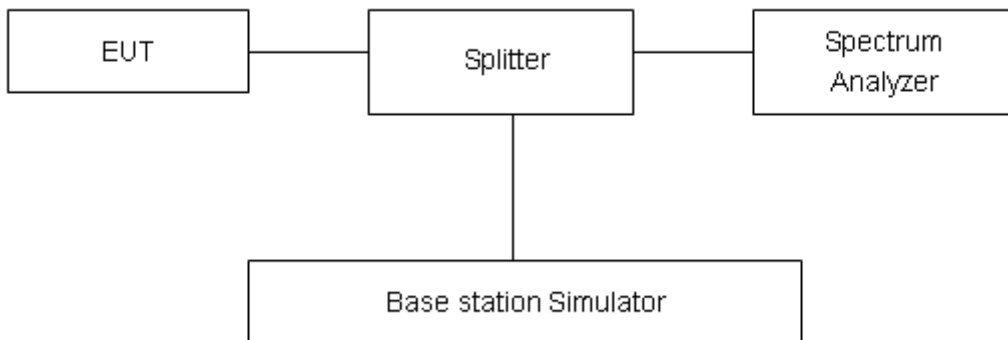

Limits

Rule Part 27.50(d)(5) Equipment employed must be authorized in accordance with the provisions of 24.51. Power measurements for transmissions by stations authorized under this section may be made either in accordance with a Commission-approved average power technique or in compliance with paragraph (d)(6) of this section. In measuring transmissions in this band using an average power technique, the peak-to-average ratio (PAR) of the transmission may not exceed 13 dB.

Measurement Uncertainty

The assessed measurement uncertainty to ensure 95% confidence level for the normal distribution is with the coverage factor $k = 2$, $U = 0.4$ dB.



Test Results

WCDMA Band IV	Channel	Frequency (MHz)	Peak (dBm)	Avg (dBm)	PAPR (dB)	Limit (dB)	Conclusion
RMC	1312	1712.4	26.41	23.60	2.81	≤13	PASS
	1413	1732.6	27.36	24.49	2.87	≤13	PASS
	1513	1752.6	27.39	24.50	2.89	≤13	PASS

LTE Band 4								
Modulation	Bandwidth (MHz)	Channel	Frequency (MHz)	Peak (dBm)	Avg (dBm)	PAPR (dB)	Limit (dB)	Conclusion
QPSK	1.4	19957	1710.7	27.08	22.63	4.45	≤13	PASS
		20175	1732.5	27.73	22.68	5.05	≤13	PASS
		20393	1754.3	27.60	22.69	4.91	≤13	PASS
	3	19965	1711.5	27.26	22.73	4.53	≤13	PASS
		20175	1732.5	27.79	22.72	5.07	≤13	PASS
		20385	1753.5	27.59	22.68	4.91	≤13	PASS
	5	19975	1712.5	27.37	22.68	4.69	≤13	PASS
		20175	1732.5	27.80	22.78	5.02	≤13	PASS
		20375	1752.5	27.52	22.73	4.79	≤13	PASS
	10	20000	1715	27.63	22.67	4.96	≤13	PASS
		20175	1732.5	27.78	22.78	5.00	≤13	PASS
		20350	1750	27.43	22.75	4.68	≤13	PASS
	15	20025	1717.5	27.67	22.05	5.62	≤13	PASS
		20175	1732.5	27.94	22.44	5.50	≤13	PASS
		20325	1747.5	27.63	22.45	5.18	≤13	PASS
	20	20050	1720	27.71	22.34	5.37	≤13	PASS
		20175	1732.5	27.94	22.68	5.26	≤13	PASS
		20300	1745	27.91	23.02	4.89	≤13	PASS
16QAM	1.4	19957	1710.7	27.00	21.68	5.32	≤13	PASS
		20175	1732.5	27.60	21.68	5.92	≤13	PASS
		20393	1754.3	27.49	21.72	5.77	≤13	PASS
	3	19965	1711.5	27.19	21.75	5.44	≤13	PASS
		20175	1732.5	27.66	21.67	5.99	≤13	PASS
		20385	1753.5	27.52	21.70	5.82	≤13	PASS
	5	19975	1712.5	27.23	21.66	5.57	≤13	PASS
		20175	1732.5	27.67	21.76	5.91	≤13	PASS
		20375	1752.5	27.41	21.75	5.66	≤13	PASS
	10	20000	1715	27.48	21.69	5.79	≤13	PASS
		20175	1732.5	27.64	21.76	5.88	≤13	PASS
		20350	1750	27.29	21.67	5.62	≤13	PASS



	15	20025	1717.5	27.34	21.10	6.24	≤13	PASS
		20175	1732.5	27.57	21.41	6.16	≤13	PASS
		20325	1747.5	27.35	21.48	5.87	≤13	PASS
	20	20050	1720	27.50	21.37	6.13	≤13	PASS
		20175	1732.5	27.69	21.62	6.07	≤13	PASS
		20300	1745	27.56	21.81	5.75	≤13	PASS

LTE Band 7								
Modulation	Bandwidth (MHz)	Channel	Frequency (MHz)	Peak (dBm)	Avg (dBm)	PAPR (dB)	Limit (dB)	Conclusion
QPSK	5	20775	2502.5	26.30	21.60	4.70	≤13	PASS
		21100	2535	26.58	21.59	4.99	≤13	PASS
		21425	2567.5	26.12	20.92	5.20	≤13	PASS
	10	20800	2505	25.95	20.93	5.02	≤13	PASS
		21100	2535	26.30	21.20	5.10	≤13	PASS
		21400	2565	25.77	20.50	5.27	≤13	PASS
	15	20825	2507.5	26.64	21.15	5.49	≤13	PASS
		21100	2535	26.93	21.44	5.49	≤13	PASS
		21375	2562.5	26.38	20.83	5.55	≤13	PASS
	20	20850	2510	26.55	21.21	5.34	≤13	PASS
		21100	2535	26.86	21.53	5.33	≤13	PASS
		21350	2560	26.31	21.02	5.29	≤13	PASS
16QAM	5	20775	2502.5	25.86	20.19	5.67	≤13	PASS
		21100	2535	26.35	20.55	5.80	≤13	PASS
		21425	2567.5	25.94	19.95	5.99	≤13	PASS
	10	20800	2505	25.68	19.83	5.85	≤13	PASS
		21100	2535	26.16	20.20	5.96	≤13	PASS
		21400	2565	25.64	19.54	6.10	≤13	PASS
	15	20825	2507.5	26.11	20.03	6.08	≤13	PASS
		21100	2535	26.43	20.34	6.09	≤13	PASS
		21375	2562.5	25.97	19.83	6.14	≤13	PASS
	20	20850	2510	26.35	20.25	6.10	≤13	PASS
		21100	2535	26.49	20.37	6.12	≤13	PASS
		21350	2560	26.09	20.02	6.07	≤13	PASS



LTE Band 13								
Modulation	Bandwidth (MHz)	Channel	Frequency (MHz)	Peak (dBm)	Avg (dBm)	PAPR (dB)	Limit (dB)	Conclusion
QPSK	5	23205	779.5	27.58	23.05	4.53	≤13	PASS
		23230	782	27.63	22.97	4.66	≤13	PASS
		23255	784.5	27.52	22.88	4.64	≤13	PASS
	10	23230	782	26.94	22.35	4.59	≤13	PASS
16QAM	5	23205	779.5	27.47	22.08	5.39	≤13	PASS
		23230	782	27.40	21.94	5.46	≤13	PASS
		23255	784.5	27.38	21.87	5.51	≤13	PASS
	10	23230	782	26.76	21.33	5.43	≤13	PASS

LTE Band 38								
Modulation	Bandwidth (MHz)	Channel	Frequency (MHz)	Peak (dBm)	Avg (dBm)	PAPR (dB)	Limit (dB)	Conclusion
QPSK	5	37775	2572.5	26.78	17.31	9.47	≤13	PASS
		38000	2595	26.92	17.65	9.27	≤13	PASS
		38225	2617.5	26.89	18.69	8.20	≤13	PASS
	10	37800	2575	26.85	18.18	8.67	≤13	PASS
		38000	2595	26.69	16.17	10.52	≤13	PASS
		38200	2615	26.95	18.82	8.13	≤13	PASS
	15	37825	2577.5	27.12	17.81	9.31	≤13	PASS
		38000	2595	27.16	17.88	9.28	≤13	PASS
		38175	2612.5	27.08	17.29	9.79	≤13	PASS
	20	37850	2580	26.74	17.41	9.33	≤13	PASS
		38000	2595	26.92	18.03	8.89	≤13	PASS
		38150	2610	27.04	18.18	8.86	≤13	PASS
16QAM	5	37775	2572.5	26.52	17.14	9.38	≤13	PASS
		38000	2595	26.50	15.68	10.82	≤13	PASS
		38225	2617.5	26.64	17.52	9.12	≤13	PASS
	10	37800	2575	26.49	15.97	10.52	≤13	PASS
		38000	2595	26.55	17.06	9.49	≤13	PASS
		38200	2615	26.73	17.45	9.28	≤13	PASS
	15	37825	2577.5	26.77	17.70	9.07	≤13	PASS
		38000	2595	26.89	17.83	9.06	≤13	PASS
		38175	2612.5	26.77	17.16	9.61	≤13	PASS



	20	37850	2580	26.48	16.14	10.34	≤13	PASS
		38000	2595	26.56	16.59	9.97	≤13	PASS
		38150	2610	26.84	17.75	9.09	≤13	PASS

LTE Band 66								
Modulation	Bandwidth (MHz)	Channel	Frequency (MHz)	Peak (dBm)	Avg (dBm)	PAPR (dB)	Limit (dB)	Conclusion
QPSK	1.4	131979	1710.7	27.04	22.56	4.48	≤13	PASS
		132322	1745	27.07	22.56	4.51	≤13	PASS
		132665	1779.3	26.84	22.68	4.16	≤13	PASS
	3	131987	1711.5	27.23	22.72	4.51	≤13	PASS
		132322	1745	27.10	22.62	4.48	≤13	PASS
		132657	1778.5	26.95	22.81	4.14	≤13	PASS
	5	131997	1712.5	27.34	22.74	4.60	≤13	PASS
		132322	1745	27.13	22.79	4.34	≤13	PASS
		132647	1777.5	26.98	22.85	4.13	≤13	PASS
	10	132022	1715	27.60	22.66	4.94	≤13	PASS
		132322	1745	27.20	22.66	4.54	≤13	PASS
		132622	1775	27.23	22.88	4.35	≤13	PASS
	15	132047	1717.5	27.81	22.39	5.42	≤13	PASS
		132322	1745	27.46	22.32	5.14	≤13	PASS
		132597	1772.5	27.60	22.47	5.13	≤13	PASS
	20	132072	1720	27.80	22.52	5.28	≤13	PASS
		132322	1745	27.52	22.45	5.07	≤13	PASS
		132572	1770	27.67	22.62	5.05	≤13	PASS
16QAM	1.4	131979	1710.7	26.94	21.57	5.37	≤13	PASS
		132322	1745	26.97	21.65	5.32	≤13	PASS
		132665	1779.3	26.83	21.71	5.12	≤13	PASS
	3	131987	1711.5	27.12	21.73	5.39	≤13	PASS
		132322	1745	27.04	21.68	5.36	≤13	PASS
		132657	1778.5	27.00	21.95	5.05	≤13	PASS
	5	131997	1712.5	27.22	21.75	5.47	≤13	PASS
		132322	1745	27.05	21.77	5.28	≤13	PASS
		132647	1777.5	26.89	21.81	5.08	≤13	PASS
	10	132022	1715	27.44	21.62	5.82	≤13	PASS
		132322	1745	27.08	21.62	5.46	≤13	PASS
		132622	1775	27.11	21.84	5.27	≤13	PASS
	15	132047	1717.5	27.50	21.39	6.11	≤13	PASS
		132322	1745	27.20	21.36	5.84	≤13	PASS



		132597	1772.5	27.29	21.41	5.88	≤13	PASS
	20	132072	1720	27.60	21.51	6.09	≤13	PASS
		132322	1745	27.35	21.47	5.88	≤13	PASS
		132572	1770	27.54	21.63	5.91	≤13	PASS

5.5 Frequency Stability

Ambient condition

Temperature	Relative humidity	Pressure
23°C ~25°C	45%~50%	101.5kPa

Method of Measurement

Frequency Stability (Temperature Variation)

The temperature inside the climate chamber is varied from 0°C to +35°C in 10°C step size.

(1)With all power removed, the temperature was decreased to -10°C and permitted to stabilize for three hours.

(2)Measure the carrier frequency with the test equipment in a “call mode”. These measurements should be made within 1 minute of powering up the mobile station, to prevent significant self warming.

(3) Repeat the above measurements at 10°C increments from 0°C to +35°C. Allow at least 1.5 hours at each temperature, un-powered, before making measurements.

Frequency Stability (Voltage Variation)

The frequency stability shall be measured with variation of primary supply voltage as follows:

Primary Supply Voltage: The primary supply voltage is varied from 85% to 115% of the nominal value for non hand-carried battery and AC powered equipment. For hand-carried, battery-powered equipment, primary supply voltage is reduced to the battery operating end point which shall be specified by the manufacturer.

This transceiver is specified to operate with an input voltage of between 3.60 V and 4.45 V, with a nominal voltage of 3.87V.

Test setup

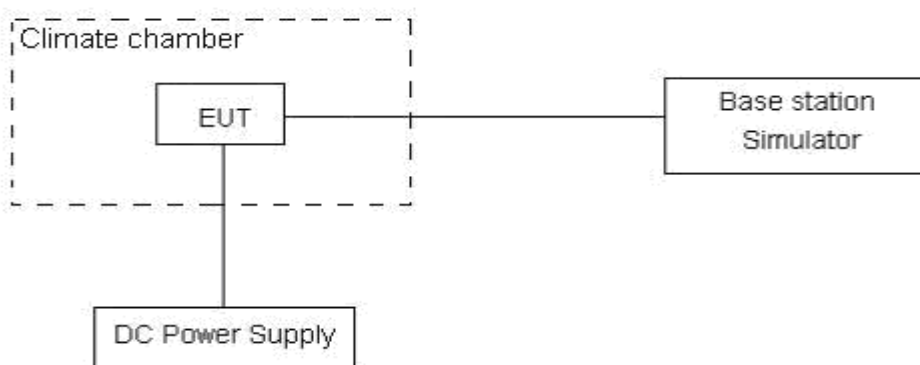

Limits

The frequency stability shall be sufficient to ensure that the fundamental emissions stay within the authorized bands of operation.

Measurement Uncertainty

The assessed measurement uncertainty to ensure 99.75% confidence level for the normal distribution is with the coverage factor $k = 3, U=0.01\text{ppm}$.



Test Result

WCDMA IV						
Condition		Freq.Error (Hz)	Freq.Error (Hz)	Frequency Stability (ppm)	Frequency Stability (ppm)	Verdict
Temperature	Voltage	BPSK	QPSK	BPSK	QPSK	
Normal (25°C)	Normal	10.86	12.03	0.00627	0.00694	PASS
Extreme (35°C)		13.85	11.08	0.00799	0.00639	PASS
Extreme (30°C)		14.73	1.86	0.00850	0.00108	PASS
Extreme (20°C)		15.08	13.64	0.00870	0.00787	PASS
Extreme (10°C)		16.50	2.34	0.00952	0.00135	PASS
Extreme (0°C)		12.80	3.99	0.00739	0.00230	PASS
25°C	LV	14.01	5.88	0.00809	0.00339	PASS
	HV	11.37	13.50	0.00657	0.00779	PASS

LTE Band 4						
Condition		Freq.Error (Hz)	Freq.Error (Hz)	Frequency Stability (ppm)	Frequency Stability (ppm)	Verdict
BANDWIDTH	1.4MHz	16QAM	QPSK	16QAM	QPSK	
Normal (25°C)	Normal	17.51	5.28	0.01011	0.00305	PASS
Extreme (35°C)		11.25	11.68	0.00649	0.00674	PASS
Extreme (30°C)		9.60	10.07	0.00554	0.00581	PASS
Extreme (20°C)		4.44	12.67	0.00256	0.00731	PASS
Extreme (10°C)		13.88	4.29	0.00801	0.00248	PASS
Extreme (0°C)		4.45	11.98	0.00257	0.00691	PASS
25°C	LV	6.80	3.30	0.00392	0.00190	PASS
	HV	15.89	8.49	0.00917	0.00490	PASS
Condition		Freq.Error (Hz)	Freq.Error (Hz)	Frequency Stability (ppm)	Frequency Stability (ppm)	Verdict
BANDWIDTH	3MHz	16QAM	QPSK	16QAM	QPSK	
Normal (25°C)	Normal	15.71	4.89	0.00907	0.00282	PASS
Extreme (35°C)		12.23	15.45	0.00706	0.00892	PASS
Extreme (30°C)		7.72	1.15	0.00445	0.00066	PASS
Extreme (20°C)		1.76	11.99	0.00101	0.00692	PASS
Extreme (10°C)		11.90	5.59	0.00687	0.00322	PASS
Extreme (0°C)		4.22	5.43	0.00244	0.00313	PASS
25°C	LV	12.63	8.97	0.00729	0.00518	PASS
	HV	7.29	16.42	0.00421	0.00948	PASS
Condition		Freq.Error (Hz)	Freq.Error (Hz)	Frequency Stability (ppm)	Frequency Stability (ppm)	Verdict
BANDWIDTH	5MHz	16QAM	QPSK	16QAM	QPSK	



Temperature	Voltage	16QAM	QPSK	16QAM	QPSK	
Normal (25°C)	Normal	9.19	6.09	0.00531	0.00351	PASS
Extreme (35°C)		16.64	17.02	0.00961	0.00982	PASS
Extreme (30°C)		15.96	10.02	0.00921	0.00578	PASS
Extreme (20°C)		5.31	17.32	0.00307	0.01000	PASS
Extreme (10°C)		3.24	7.17	0.00187	0.00414	PASS
Extreme (0°C)		11.33	16.40	0.00654	0.00947	PASS
25°C	LV	12.85	9.11	0.00742	0.00526	PASS
	HV	15.41	16.10	0.00889	0.00929	PASS
Condition		Freq.Error (Hz)	Freq.Error (Hz)	Frequency Stability (ppm)	Frequency Stability (ppm)	Verdict
BANDWIDTH	10MHz					
Temperature	Voltage	16QAM	QPSK	16QAM	QPSK	
Normal (25°C)	Normal	16.61	14.15	0.00959	0.00817	PASS
Extreme (35°C)		8.16	1.31	0.00471	0.00075	PASS
Extreme (30°C)		10.80	10.50	0.00623	0.00606	PASS
Extreme (20°C)		17.24	12.08	0.00995	0.00697	PASS
Extreme (10°C)		6.14	12.29	0.00354	0.00709	PASS
Extreme (0°C)		14.80	14.95	0.00854	0.00863	PASS
25°C	LV	7.54	10.80	0.00435	0.00624	PASS
	HV	5.95	13.41	0.00343	0.00774	PASS
Condition		Freq.Error (Hz)	Freq.Error (Hz)	Frequency Stability (ppm)	Frequency Stability (ppm)	Verdict
BANDWIDTH	15MHz					
Temperature	Voltage	16QAM	QPSK	16QAM	QPSK	
Normal (25°C)	Normal	4.49	13.64	0.00259	0.00787	PASS
Extreme (35°C)		1.75	1.44	0.00101	0.00083	PASS
Extreme (30°C)		3.41	8.84	0.00197	0.00510	PASS
Extreme (20°C)		13.74	2.59	0.00793	0.00149	PASS
Extreme (10°C)		17.08	17.94	0.00986	0.01036	PASS
Extreme (0°C)		12.08	3.15	0.00697	0.00182	PASS
25°C	LV	13.87	12.97	0.00801	0.00749	PASS
	HV	4.96	14.21	0.00286	0.00820	PASS
Condition		Freq.Error (Hz)	Freq.Error (Hz)	Frequency Stability (ppm)	Frequency Stability (ppm)	Verdict
BANDWIDTH	20MHz					
Temperature	Voltage	16QAM	QPSK	16QAM	QPSK	
Normal (25°C)	Normal	7.70	4.34	0.00445	0.00250	PASS
Extreme (35°C)		5.74	11.96	0.00331	0.00690	PASS
Extreme (30°C)		15.53	16.87	0.00896	0.00974	PASS
Extreme (20°C)		5.71	12.62	0.00330	0.00728	PASS
Extreme (10°C)		15.63	9.36	0.00902	0.00540	PASS
Extreme (0°C)		3.02	16.67	0.00174	0.00962	PASS



25°C	LV	13.42	9.05	0.00775	0.00522	PASS
	HV	12.03	3.01	0.00694	0.00174	PASS

LTE Band 7						
Condition		Freq.Error (Hz)	Freq.Error (Hz)	Frequency Stability (ppm)	Frequency Stability (ppm)	Verdict
BANDWIDTH	5MHz					
Temperature	Voltage	16QAM	QPSK	16QAM	QPSK	
Normal (25°C)	Normal	11.56	6.59	0.00456	0.00260	PASS
Extreme (35°C)		11.10	6.41	0.00438	0.00253	PASS
Extreme (30°C)		17.92	4.45	0.00707	0.00176	PASS
Extreme (20°C)		10.87	17.26	0.00429	0.00681	PASS
Extreme (10°C)		6.02	6.69	0.00237	0.00264	PASS
Extreme (0°C)		3.59	14.20	0.00142	0.00560	PASS
25°C	LV	16.46	1.60	0.00649	0.00063	PASS
	HV	5.13	17.35	0.00202	0.00684	PASS
Condition		Freq.Error (Hz)	Freq.Error (Hz)	Frequency Stability (ppm)	Frequency Stability (ppm)	Verdict
BANDWIDTH	10MHz					
Temperature	Voltage	16QAM	QPSK	16QAM	QPSK	
Normal (25°C)	Normal	13.05	2.75	0.00515	0.00108	PASS
Extreme (35°C)		5.66	7.98	0.00223	0.00315	PASS
Extreme (30°C)		6.44	12.08	0.00254	0.00477	PASS
Extreme (20°C)		11.41	6.99	0.00450	0.00276	PASS
Extreme (10°C)		2.92	4.72	0.00115	0.00186	PASS
Extreme (0°C)		4.78	16.36	0.00189	0.00645	PASS
25°C	LV	6.69	11.27	0.00264	0.00444	PASS
	HV	4.48	8.28	0.00177	0.00327	PASS
Condition		Freq.Error (Hz)	Freq.Error (Hz)	Frequency Stability (ppm)	Frequency Stability (ppm)	Verdict
BANDWIDTH	15MHz					
Temperature	Voltage	16QAM	QPSK	16QAM	QPSK	
Normal (25°C)	Normal	12.13	16.96	0.00478	0.00669	PASS
Extreme (35°C)		15.33	1.96	0.00605	0.00077	PASS
Extreme (30°C)		15.64	8.81	0.00617	0.00348	PASS
Extreme (20°C)		10.56	12.04	0.00417	0.00475	PASS
Extreme (10°C)		9.31	3.56	0.00367	0.00141	PASS
Extreme (0°C)		6.17	17.21	0.00243	0.00679	PASS
25°C	LV	15.05	3.35	0.00594	0.00132	PASS
	HV	8.85	16.44	0.00349	0.00649	PASS
Condition		Freq.Error (Hz)	Freq.Error (Hz)	Frequency Stability (ppm)	Frequency Stability (ppm)	Verdict
BANDWIDTH	20MHz					



Temperature	Voltage	16QAM	QPSK	16QAM	QPSK	
Normal (25°C)	Normal	5.63	13.65	0.00222	0.00538	PASS
Extreme (35°C)		14.69	17.19	0.00579	0.00678	PASS
Extreme (30°C)		4.35	4.62	0.00171	0.00182	PASS
Extreme (20°C)		4.46	10.09	0.00176	0.00398	PASS
Extreme (10°C)		13.47	2.20	0.00531	0.00087	PASS
Extreme (0°C)		12.73	4.57	0.00502	0.00180	PASS
25°C	LV	13.16	3.52	0.00519	0.00139	PASS
	HV	14.35	2.68	0.00566	0.00106	PASS

LTE Band 13						
Condition		Freq.Error (Hz)	Freq.Error (Hz)	Frequency Stability (ppm)	Frequency Stability (ppm)	Verdict
BANDWIDTH	5MHz					
Temperature	Voltage	16QAM	QPSK	16QAM	QPSK	
Normal (25°C)	Normal	3.10	3.63	0.00396	0.00464	PASS
Extreme (35°C)		4.94	13.28	0.00631	0.01699	PASS
Extreme (30°C)		1.65	9.25	0.00210	0.01183	PASS
Extreme (20°C)		3.42	15.04	0.00437	0.01924	PASS
Extreme (10°C)		1.73	13.58	0.00221	0.01737	PASS
Extreme (0°C)		1.48	1.82	0.00189	0.00233	PASS
25°C	LV	17.36	4.67	0.02220	0.00597	PASS
	HV	2.35	17.48	0.00300	0.02236	PASS
Condition		Freq.Error (Hz)	Freq.Error (Hz)	Frequency Stability (ppm)	Frequency Stability (ppm)	Verdict
BANDWIDTH	10MHz					
Temperature	Voltage	16QAM	QPSK	16QAM	QPSK	
Normal (25°C)	Normal	7.32	12.67	0.00936	0.01620	PASS
Extreme (35°C)		17.44	9.60	0.02230	0.01227	PASS
Extreme (30°C)		5.21	11.32	0.00666	0.01448	PASS
Extreme (20°C)		9.68	10.64	0.01238	0.01360	PASS
Extreme (10°C)		12.64	5.80	0.01616	0.00742	PASS
Extreme (0°C)		9.76	15.23	0.01248	0.01947	PASS
25°C	LV	15.17	3.63	0.01940	0.00464	PASS
	HV	3.41	8.11	0.00436	0.01037	PASS

LTE Band 38						
Condition		Freq.Error (Hz)	Freq.Error (Hz)	Frequency Stability (ppm)	Frequency Stability (ppm)	Verdict
BANDWIDTH	5MHz					
Temperature	Voltage	16QAM	QPSK	16QAM	QPSK	
Normal (25°C)	Normal	7.79	13.56	0.00300	0.00523	PASS
Extreme (35°C)		1.61	10.20	0.00062	0.00393	PASS



Extreme (30°C)		12.59	17.72	0.00485	0.00683	PASS
Extreme (20°C)		4.92	16.61	0.00190	0.00640	PASS
Extreme (10°C)		15.95	14.70	0.00615	0.00566	PASS
Extreme (0°C)		10.51	11.39	0.00405	0.00439	PASS
25°C	LV	14.85	11.86	0.00572	0.00457	PASS
	HV	6.52	8.79	0.00251	0.00339	PASS
Condition		Freq.Error (Hz)	Freq.Error (Hz)	Frequency Stability (ppm)	Frequency Stability (ppm)	Verdict
BANDWIDTH	10MHz					
Temperature	Voltage	16QAM	QPSK	16QAM	QPSK	
Normal (25°C)	Normal	16.64	10.61	0.00641	0.00409	PASS
Extreme (35°C)		7.07	1.78	0.00272	0.00068	PASS
Extreme (30°C)		15.42	12.34	0.00594	0.00475	PASS
Extreme (20°C)		9.42	15.09	0.00363	0.00581	PASS
Extreme (10°C)		9.63	5.58	0.00371	0.00215	PASS
Extreme (0°C)		10.03	11.72	0.00386	0.00452	PASS
25°C	LV	5.78	1.17	0.00223	0.00045	PASS
	HV	12.72	17.30	0.00490	0.00667	PASS
Condition		Freq.Error (Hz)	Freq.Error (Hz)	Frequency Stability (ppm)	Frequency Stability (ppm)	Verdict
BANDWIDTH	15MHz					
Temperature	Voltage	16QAM	QPSK	16QAM	QPSK	
Normal (25°C)	Normal	14.39	1.73	0.00554	0.00066	PASS
Extreme (35°C)		1.68	13.46	0.00065	0.00519	PASS
Extreme (30°C)		11.97	10.68	0.00461	0.00412	PASS
Extreme (20°C)		8.34	14.37	0.00321	0.00554	PASS
Extreme (10°C)		10.21	15.54	0.00393	0.00599	PASS
Extreme (0°C)		1.15	14.09	0.00044	0.00543	PASS
25°C	LV	2.76	2.67	0.00106	0.00103	PASS
	HV	14.76	2.48	0.00569	0.00096	PASS
Condition		Freq.Error (Hz)	Freq.Error (Hz)	Frequency Stability (ppm)	Frequency Stability (ppm)	Verdict
BANDWIDTH	20MHz					
Temperature	Voltage	16QAM	QPSK	16QAM	QPSK	
Normal (25°C)	Normal	1.00	2.92	0.00039	0.00113	PASS
Extreme (35°C)		15.00	17.27	0.00578	0.00666	PASS
Extreme (30°C)		16.00	6.78	0.00617	0.00261	PASS
Extreme (20°C)		2.00	14.42	0.00077	0.00556	PASS
Extreme (10°C)		1.00	11.06	0.00039	0.00426	PASS
Extreme (0°C)		6.00	12.05	0.00231	0.00465	PASS
25°C	LV	17.00	2.93	0.00655	0.00113	PASS
	HV	13.00	16.32	0.00501	0.00629	PASS



LTE Band 66						
Condition		Freq.Error (Hz)	Freq.Error (Hz)	Frequency Stability (ppm)	Frequency Stability (ppm)	Verdict
BANDWIDTH	1.4MHz					
Temperature	Voltage	16QAM	QPSK	16QAM	QPSK	
Normal (25°C)	Normal	4.07	15.46	0.00233	0.00886	PASS
Extreme (35°C)		4.09	2.64	0.00234	0.00151	PASS
Extreme (30°C)		4.24	4.70	0.00243	0.00269	PASS
Extreme (20°C)		11.74	6.65	0.00673	0.00381	PASS
Extreme (10°C)		5.78	3.24	0.00331	0.00185	PASS
Extreme (0°C)		9.52	8.72	0.00546	0.00500	PASS
25°C	LV	1.96	11.75	0.00112	0.00673	PASS
	HV	14.53	12.21	0.00832	0.00700	PASS
Condition		Freq.Error (Hz)	Freq.Error (Hz)	Frequency Stability (ppm)	Frequency Stability (ppm)	Verdict
BANDWIDTH	3MHz					
Temperature	Voltage	16QAM	QPSK	16QAM	QPSK	
Normal (25°C)	Normal	3.83	4.46	0.00220	0.00255	PASS
Extreme (35°C)		14.07	5.64	0.00806	0.00323	PASS
Extreme (30°C)		2.12	1.12	0.00121	0.00064	PASS
Extreme (20°C)		11.09	7.97	0.00636	0.00457	PASS
Extreme (10°C)		4.81	8.85	0.00276	0.00507	PASS
Extreme (0°C)		12.10	10.39	0.00694	0.00596	PASS
25°C	LV	7.70	13.28	0.00441	0.00761	PASS
	HV	9.45	5.41	0.00541	0.00310	PASS
Condition		Freq.Error (Hz)	Freq.Error (Hz)	Frequency Stability (ppm)	Frequency Stability (ppm)	Verdict
BANDWIDTH	5MHz					
Temperature	Voltage	16QAM	QPSK	16QAM	QPSK	
Normal (25°C)	Normal	4.05	9.60	0.00232	0.00550	PASS
Extreme (35°C)		1.95	10.70	0.00112	0.00613	PASS
Extreme (30°C)		11.14	11.25	0.00638	0.00645	PASS
Extreme (20°C)		4.51	9.98	0.00258	0.00572	PASS
Extreme (10°C)		6.04	3.09	0.00346	0.00177	PASS
Extreme (0°C)		4.07	7.96	0.00233	0.00456	PASS
25°C	LV	1.05	11.88	0.00060	0.00681	PASS
	HV	5.66	8.90	0.00324	0.00510	PASS
Condition		Freq.Error (Hz)	Freq.Error (Hz)	Frequency Stability	Frequency Stability	Verdict



BANDWIDTH		10MHz			(ppm)	(ppm)	
Temperature		Voltage	16QAM	QPSK	16QAM	QPSK	
Normal (25°C)		Normal	14.85	12.83	0.00851	0.00736	PASS
Extreme (35°C)			4.50	4.85	0.00258	0.00278	PASS
Extreme (30°C)			15.33	6.83	0.00878	0.00392	PASS
Extreme (20°C)			10.59	10.51	0.00607	0.00602	PASS
Extreme (10°C)			9.72	6.22	0.00557	0.00357	PASS
Extreme (0°C)			4.68	6.32	0.00268	0.00362	PASS
25°C			LV	15.69	4.74	0.00899	0.00272
		HV	2.06	3.01	0.00118	0.00172	PASS
Condition			Freq.Error (Hz)	Freq.Error (Hz)	Frequency Stability (ppm)	Frequency Stability (ppm)	Verdict
BANDWIDTH	15MHz						
Temperature		Voltage	16QAM	QPSK	16QAM	QPSK	
Normal (25°C)		Normal	5.59	16.43	0.00320	0.00942	PASS
Extreme (35°C)			3.25	17.76	0.00186	0.01018	PASS
Extreme (30°C)			16.58	16.91	0.00950	0.00969	PASS
Extreme (20°C)			13.62	6.16	0.00781	0.00353	PASS
Extreme (10°C)			2.34	7.58	0.00134	0.00434	PASS
Extreme (0°C)			16.14	12.58	0.00925	0.00721	PASS
25°C			LV	7.86	2.34	0.00450	0.00134
		HV	10.34	1.15	0.00592	0.00066	PASS
Condition			Freq.Error (Hz)	Freq.Error (Hz)	Frequency Stability (ppm)	Frequency Stability (ppm)	Verdict
BANDWIDTH	20MHz						
Temperature		Voltage	16QAM	QPSK	16QAM	QPSK	
Normal (25°C)		Normal	5.00	16.31	0.00287	0.00935	PASS
Extreme (35°C)			14.00	8.72	0.00802	0.00500	PASS
Extreme (30°C)			17.00	6.73	0.00974	0.00386	PASS
Extreme (20°C)			12.00	10.07	0.00688	0.00577	PASS
Extreme (10°C)			2.00	4.91	0.00115	0.00282	PASS
Extreme (0°C)			14.00	2.33	0.00802	0.00133	PASS
25°C			LV	10.00	7.61	0.00573	0.00436
		HV	4.00	4.84	0.00229	0.00277	PASS

5.6 Spurious Emissions at Antenna Terminals

Ambient condition

Temperature	Relative humidity	Pressure
23°C ~25°C	45%~50%	101.5kPa

Method of Measurement

The EUT was connected to Spectrum Analyzer and Base Station Simulator via power Splitter. The measurement is carried out using a spectrum analyzer. The spectrum analyzer scans from 9kHz to the 10th harmonic of the carrier. The peak detector is used.

RBW is set to 100kHz, VBW is set to 300kHz for 30MHz~1GHz

RBW is set to 1MHz, VBW is set to 3MHz for above 1GHz, Sweep is set to ATUO.

RBW is set to 1 kHz (0.009MHz~ 0.15 MHz),

RBW is set to 10 kHz (0.15 MHz~ 30 MHz)

RBW is set to 100 kHz (30MHz~1000 MHz)

RBW is set to 1000 kHz (above 1000MHz)

Of those disturbances below (limit – 20 dB), the mark is not required for the EUT.

The modulation mode and RB allocation refer to section 5.1, using the maximum output power configuration.

Test setup

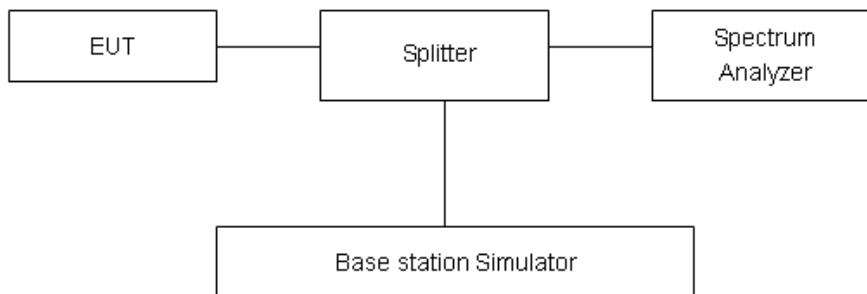

Limits

Rule Part 27.53(h) specifies that “for operations in the 1695-1710 MHz, 1710-1755 MHz, 1755-1780 MHz, 1915-1920 MHz, 1995-2000 MHz, 2000-2020 MHz, 2110-2155 MHz, 2155-2180 MHz, and 2180-2200 bands, the power of any emission outside a licensee's frequency block shall be attenuated below the transmitter power (P) in watts by at least $43 + 10 \log_{10} (P)$ dB..”

Rule Part 27.53(f) For operations in the 746-758 MHz, 775-788 MHz, and 805-806 MHz bands, emissions in the band 1559-1610 MHz shall be limited to –70 dBW/MHz equivalent isotropically radiated power (EIRP) for wideband signals, and –80 dBW EIRP for discrete emissions of less than 700 Hz bandwidth. For the purpose of equipment authorization, a transmitter shall be tested with an antenna that is representative of the type that will be used with the equipment in normal operation.

Rule Part 27.53(m) $55 + 10 \log (P)$ dB on all frequencies more than X megahertz from the channel

edge, where X is the greater of 6 megahertz or the actual emission bandwidth as defined in paragraph (m)(4) of this section.

Part 27.53 (c) For operations in the 746-758 MHz band and the 776-788 MHz band, the power of any emission outside the licensee's frequency band(s) of operation shall be attenuated below the transmitter power (P) within the licensed band(s) of operation, measured in watts, in accordance with the following:

- (1) On any frequency outside the 746-758 MHz band, the power of any emission shall be attenuated outside the band below the transmitter power (P) by at least $43 + 10 \log (P)$ dB;
- (2) On any frequency outside the 776-788 MHz band, the power of any emission shall be attenuated outside the band below the transmitter power (P) by at least $43 + 10 \log (P)$ dB;
- (3) On all frequencies between 763-775 MHz and 793-805 MHz, by a factor not less than $76 + 10 \log (P)$ dB in a 6.25 kHz band segment, for base and fixed stations;
- (4) On all frequencies between 763-775 MHz and 793-805 MHz, by a factor not less than $65 + 10 \log (P)$ dB in a 6.25 kHz band segment, for mobile and portable stations;
- (5) Compliance with the provisions of paragraphs (c)(1) and (c)(2) of this section is based on the use of measurement instrumentation employing a resolution bandwidth of 100 kHz or greater. However, in the 100 kHz bands immediately outside and adjacent to the frequency block, a resolution bandwidth of at least 30 kHz may be employed;

Part 27.53(h) Limit		-13 dBm
Part 27.53(f) Limit	Limit out of the band 1559-1610 MHz	-13 dBm
	Limit in the band 1559-1610 MHz	-40 dBm
Part 27.53(m) Limit		-25 dBm

Measurement Uncertainty

The assessed measurement uncertainty to ensure 99.75% confidence level for the normal distribution is with the coverage factor $k = 1.96$.

Frequency	Uncertainty
9kHz-1GHz	0.684 dB
1GHz-30GHz	1.407 dB



Test Result

Sweep the whole frequency band through the range from 9kHz to the 10th harmonic of the carrier, the emissions more than 20 dB below the limit are not reported.

The signal beyond the limit is carrier.

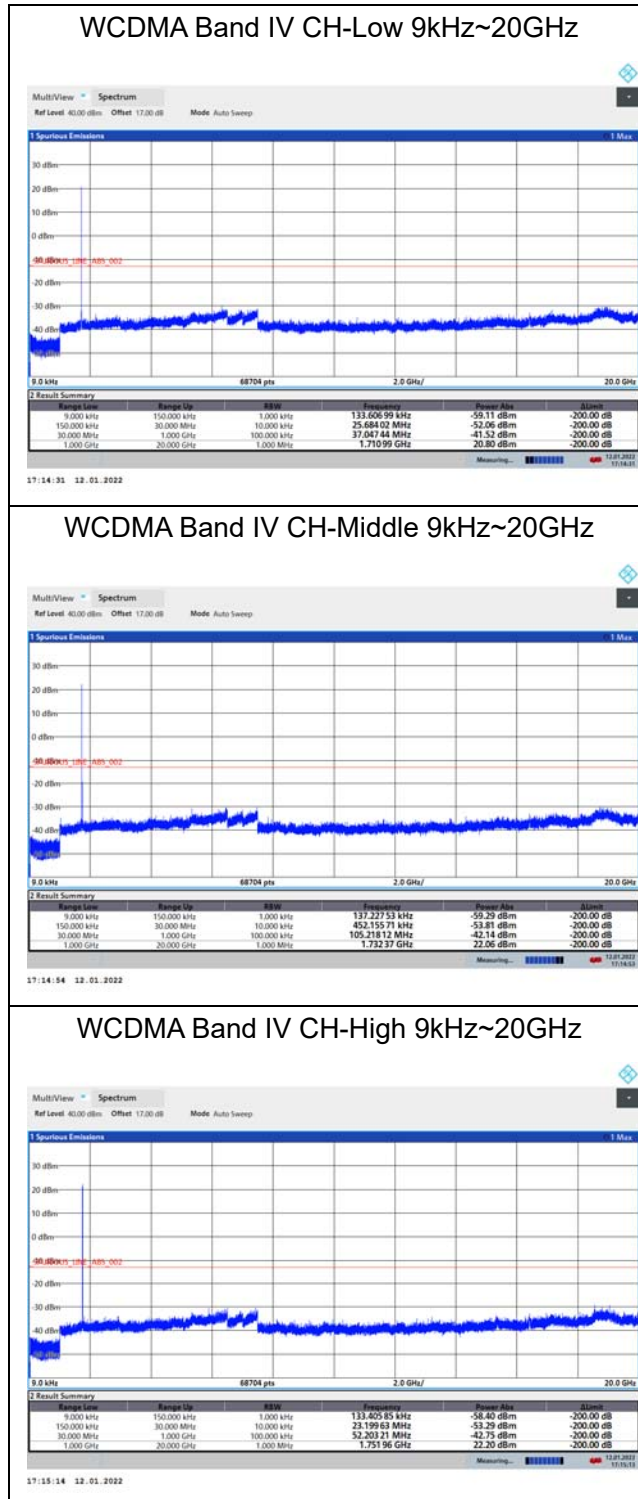



LTE Band 4 1.4MHz CH-Low 9kHz~20GHz

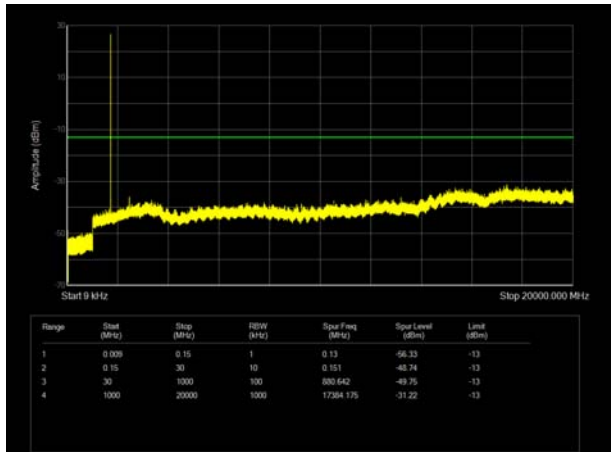

LTE Band 4 3MHz CH- Low 9kHz~20GHz

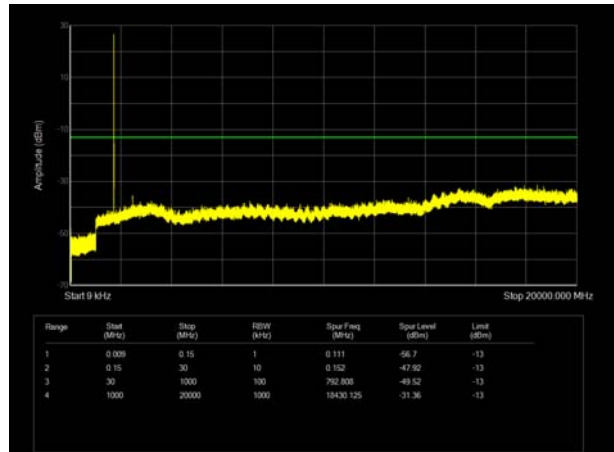

LTE Band 4 1.4MHz CH- Middle 9kHz~20GHz

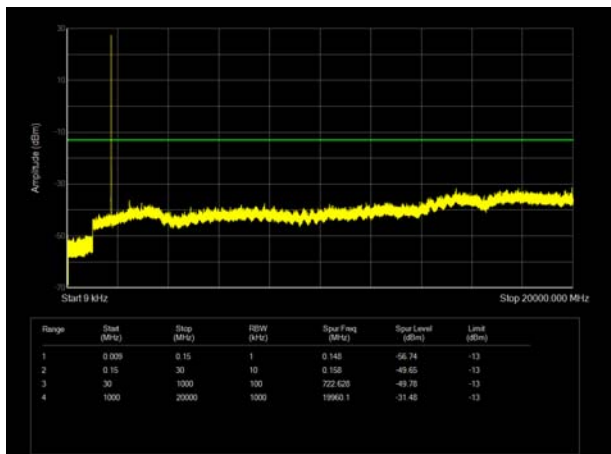

LTE Band 4 3MHz CH- Middle 9kHz~20GHz

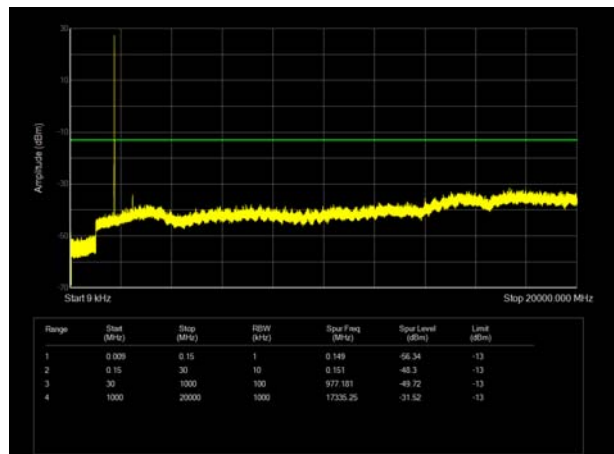

LTE Band 4 1.4MHz CH- High 9kHz~20GHz

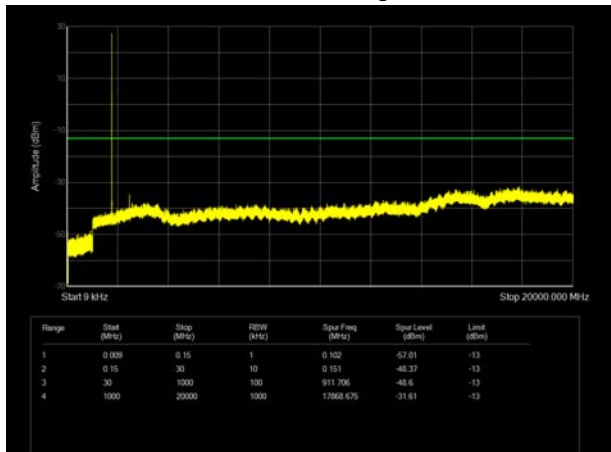

LTE Band 4 3MHz CH-High 9kHz~20GHz

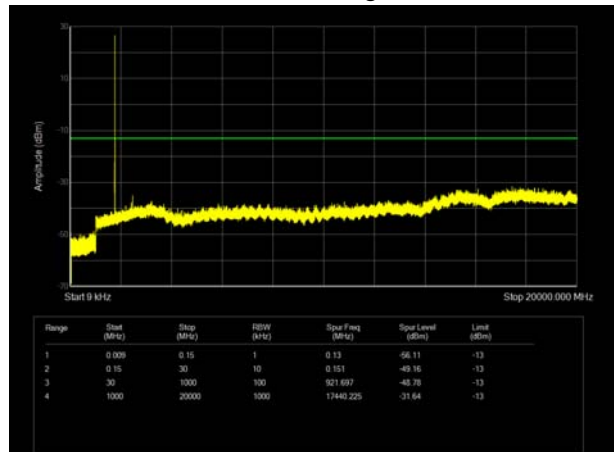



LTE Band 4 5MHz CH- Low 9kHz~20GHz

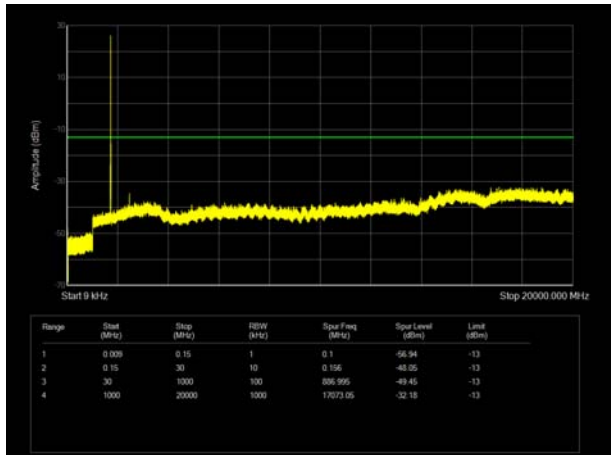

LTE Band 4 10MHz CH-Low 9kHz~20GHz

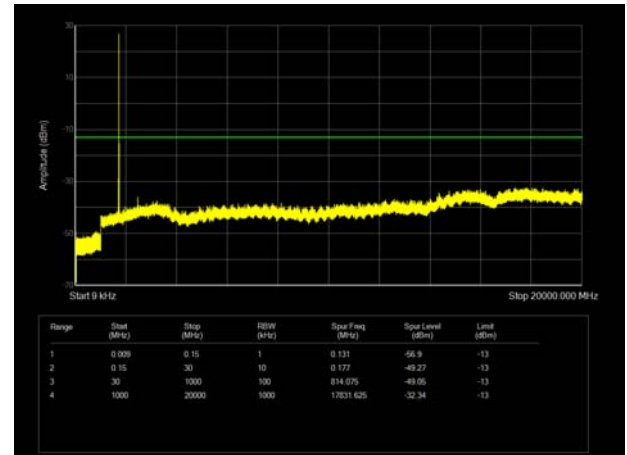

LTE Band 4 5MHz CH- Middle 9kHz~20GHz

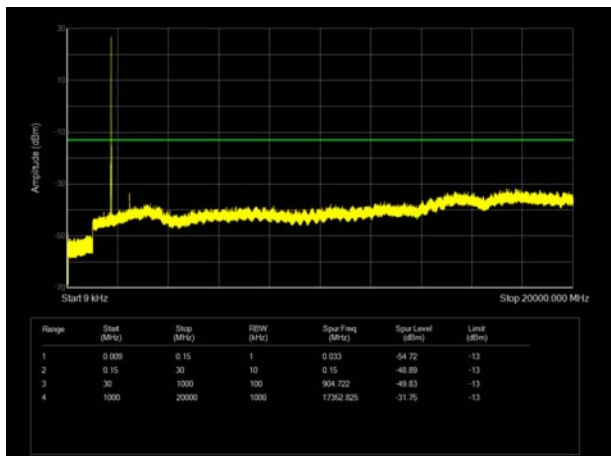

LTE Band 4 10MHz CH- Middle 9kHz~20GHz

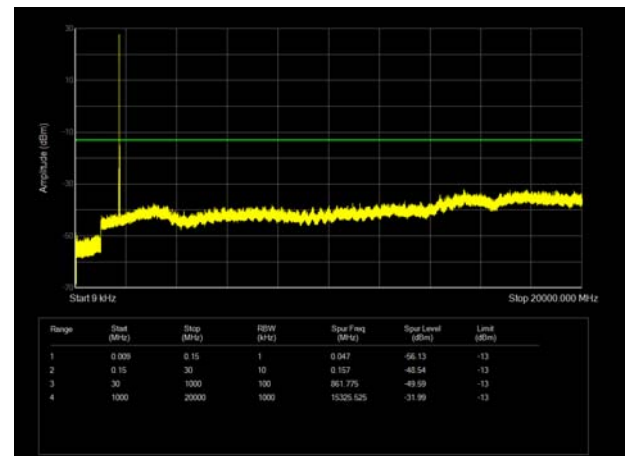

LTE Band 4 5MHz CH-High 9kHz~20GHz

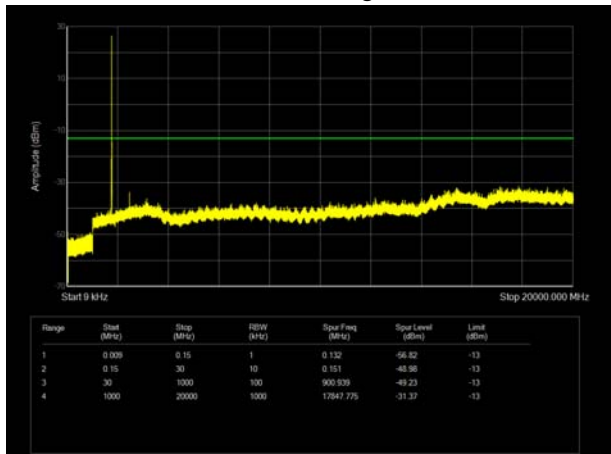

LTE Band 4 10MHz CH- High 9kHz~20GHz

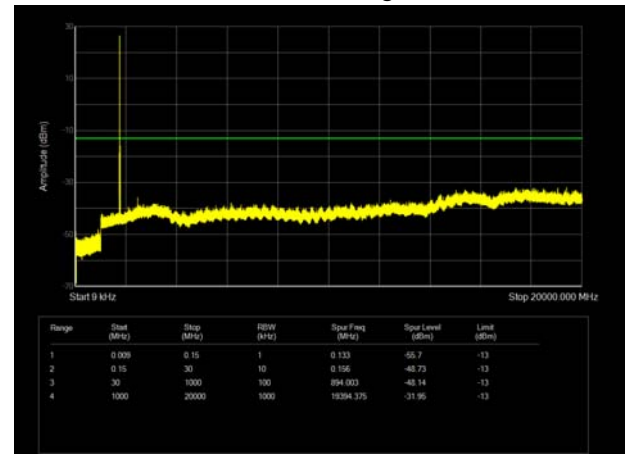



LTE Band 4 15MHz CH- Low 9kHz~20GHz

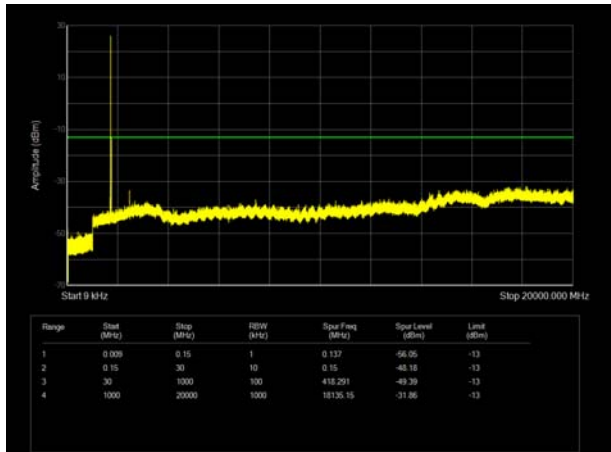

LTE Band 4 20MHz CH-Low 9kHz~20GHz

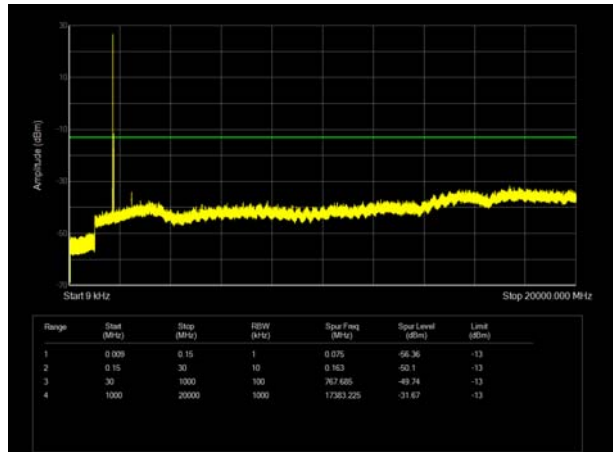

LTE Band 4 15MHz CH- Middle 9kHz~20GHz

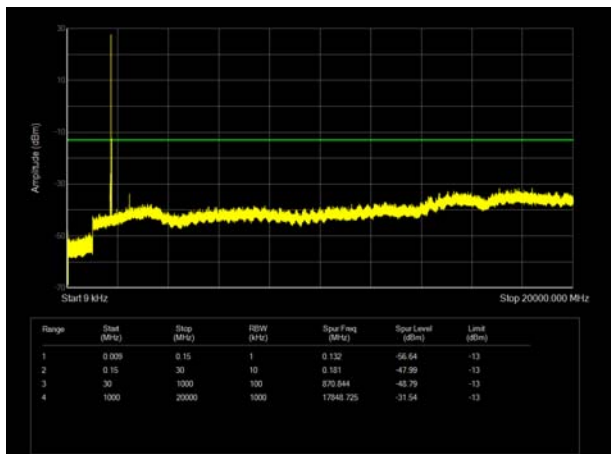

LTE Band 4 20MHz CH- Middle 9kHz~20GHz

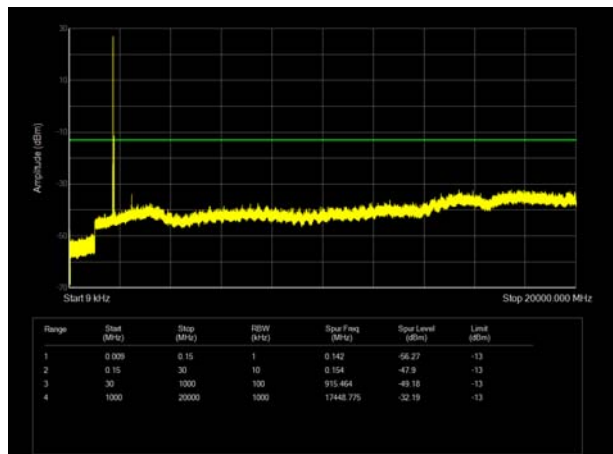

LTE Band 4 15MHz CH-High 9kHz~20GHz

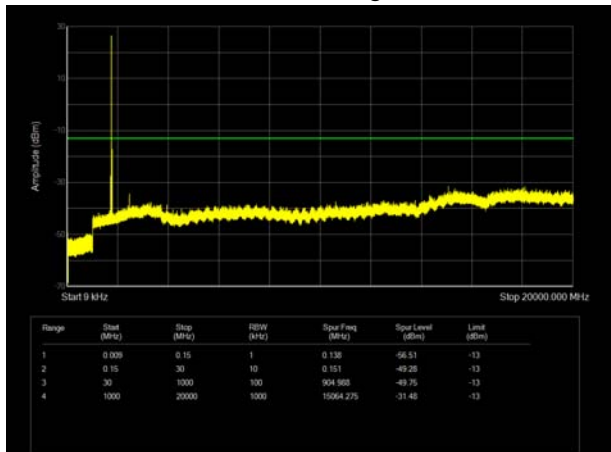

LTE Band 4 20MHz CH- High 9kHz~20GHz

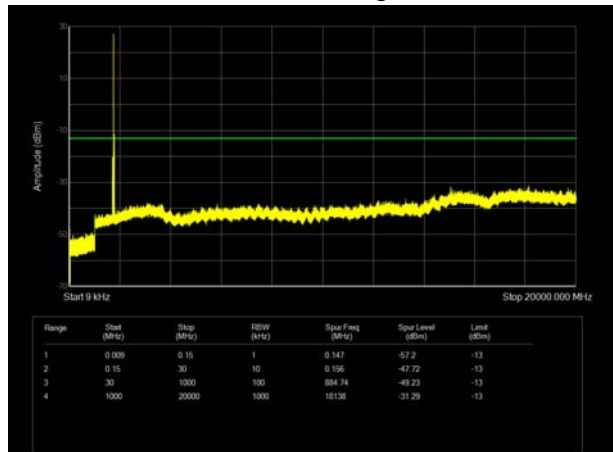



LTE Band 7 5MHz CH- Low 9kHz~30GHz

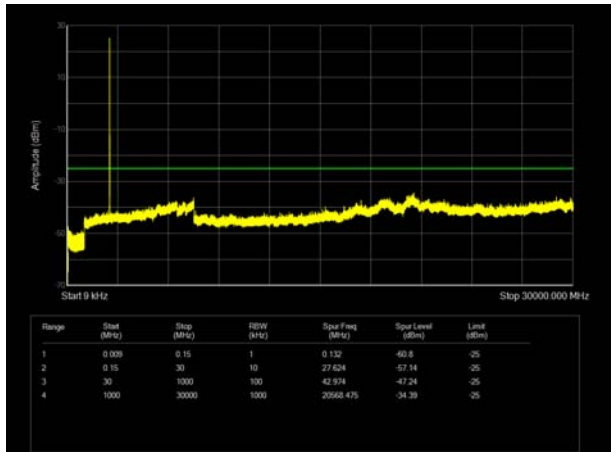

LTE Band 7 10MHz CH-Low 9kHz~30GHz

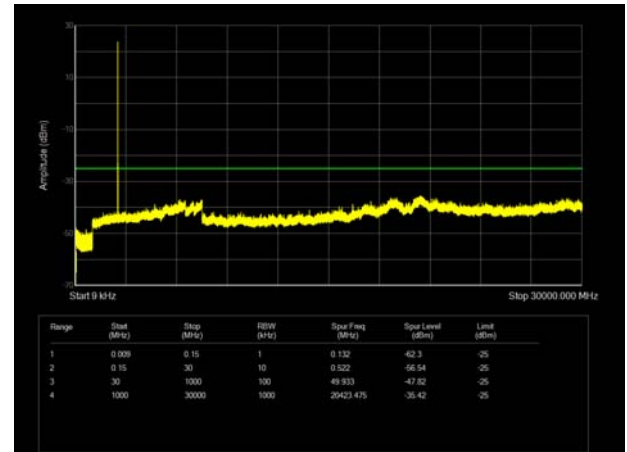

LTE Band 7 5MHz CH- Middle 9kHz~30GHz

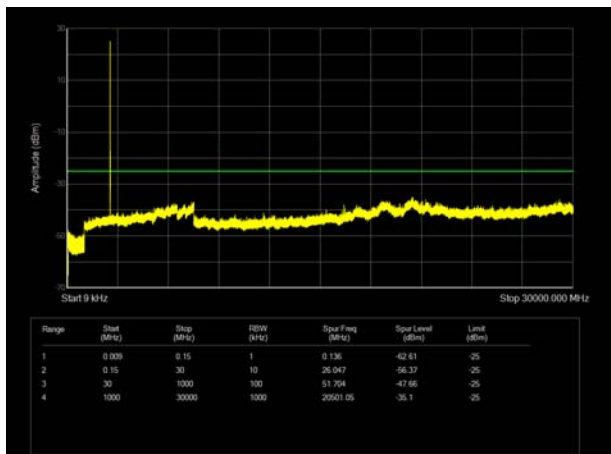

LTE Band 7 10MHz CH- Middle 9kHz~30GHz

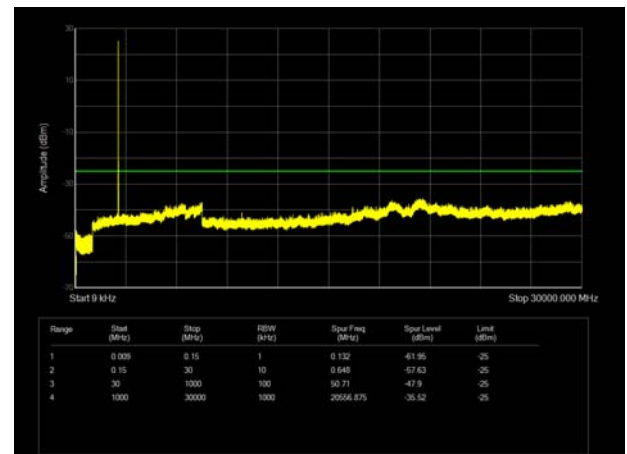

LTE Band 7 5MHz CH-High 9kHz~30GHz

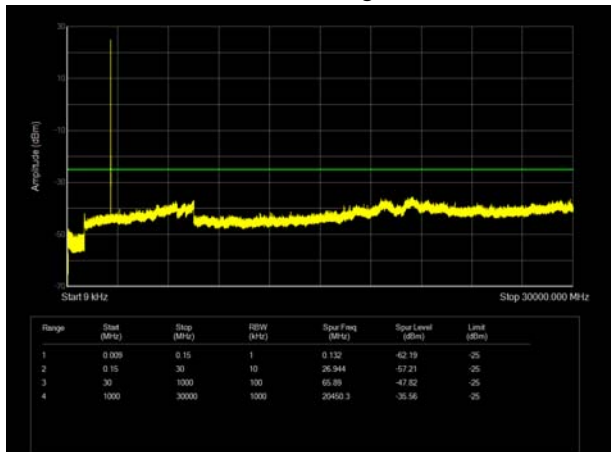

LTE Band 7 10MHz CH- High 9kHz~30GHz

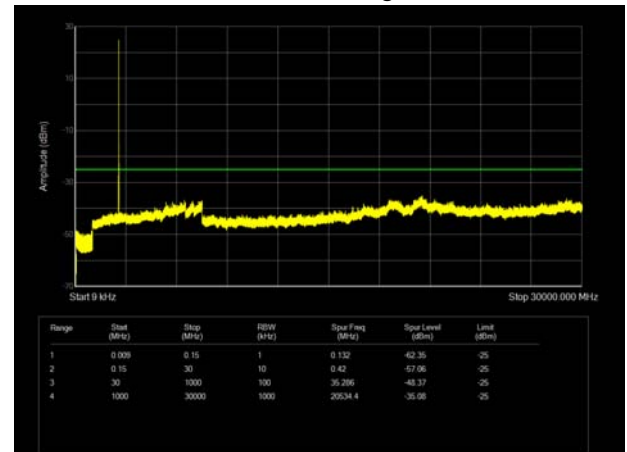



LTE Band 7 15MHz CH- Low 9kHz~30GHz

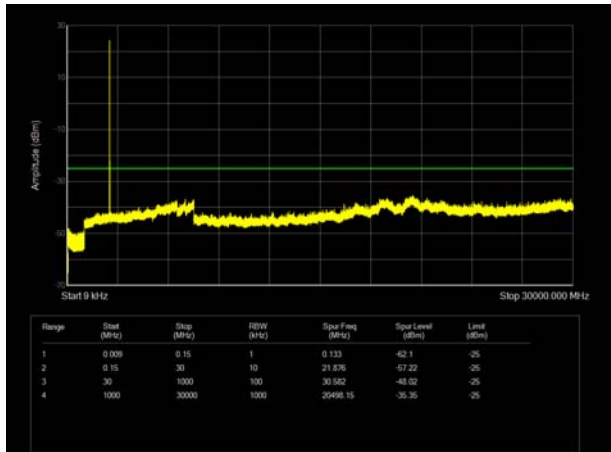

LTE Band 7 20MHz CH-Low 9kHz~30GHz

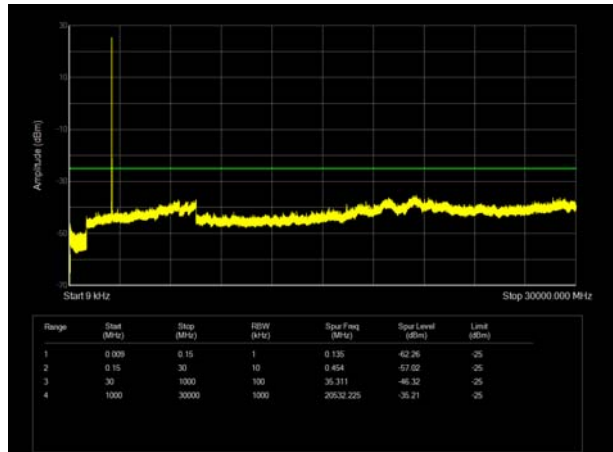

LTE Band 7 15MHz CH- Middle 9kHz~30GHz

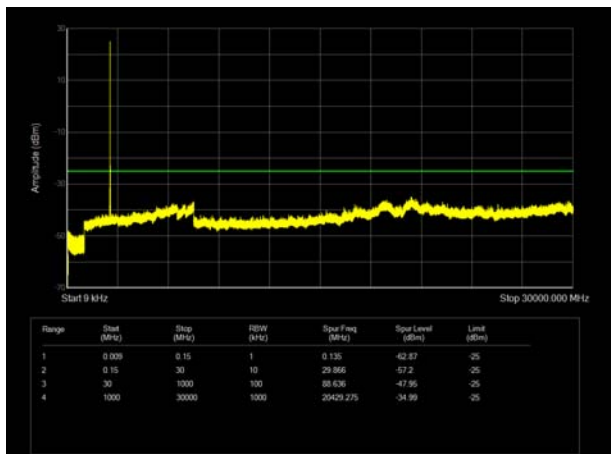

LTE Band 7 20MHz CH- Middle 9kHz~30GHz

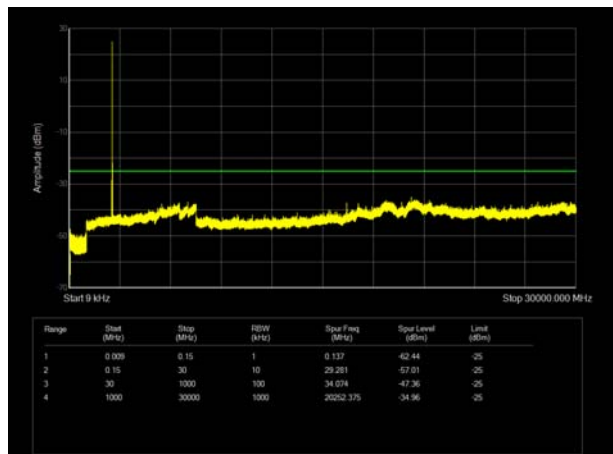

LTE Band 7 15MHz CH-High 9kHz~30GHz

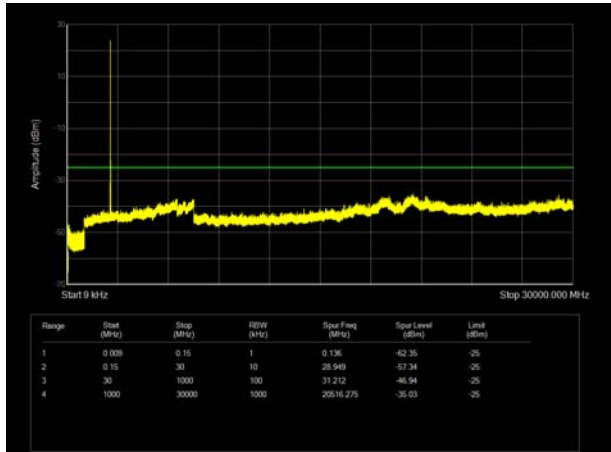

LTE Band 7 20MHz CH- High 9kHz~30GHz

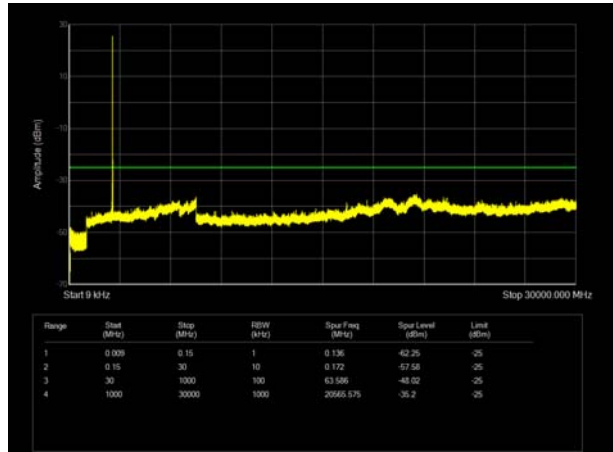



LTE Band 13 5MHz CH-Low 9kHz ~12.75GHz

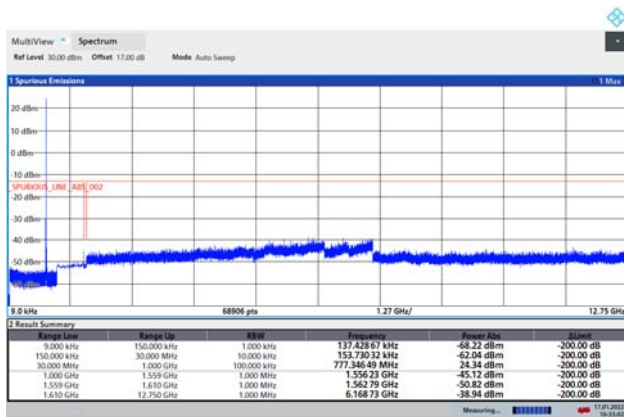

14:33:03 17.01.2022

LTE Band 13 5MHz CH-Middle 9kHz ~12.75GHz

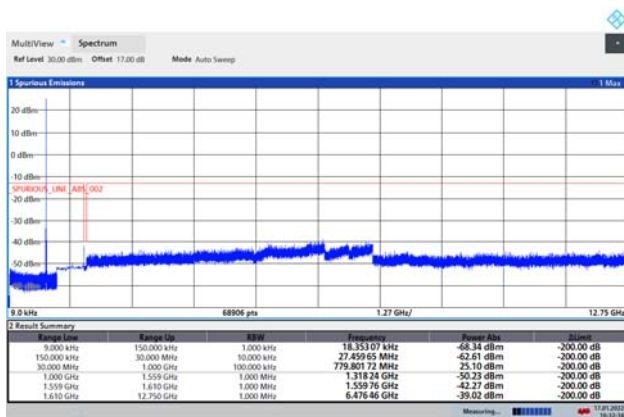

14:32:35 17.01.2022

LTE Band 13 10MHz CH-Middle 9kHz ~12.75GHz

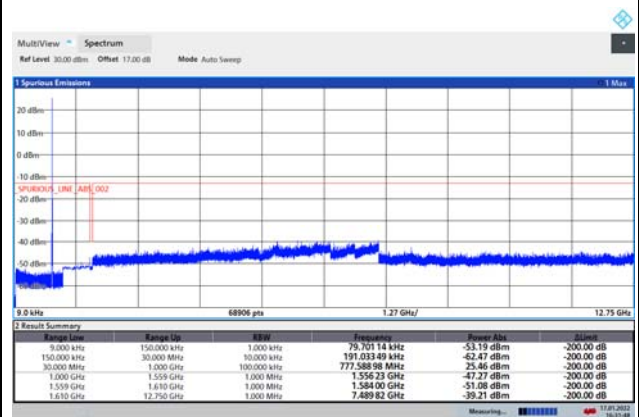

14:31:48 17.01.2022

LTE Band 13 5MHz CH-High 9kHz ~12.75GHz

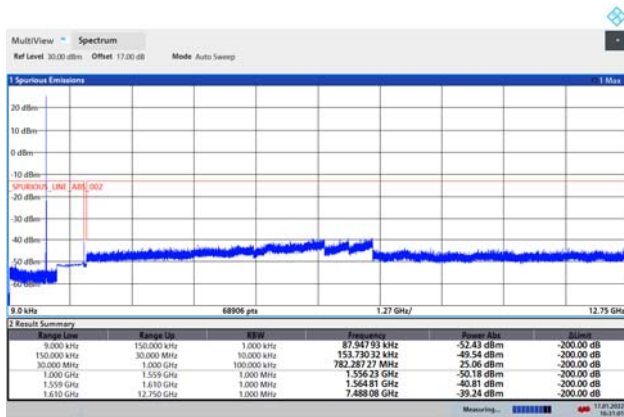

14:31:02 17.01.2022



LTE Band 38 5MHz CH-Low 9kHz~30GHz

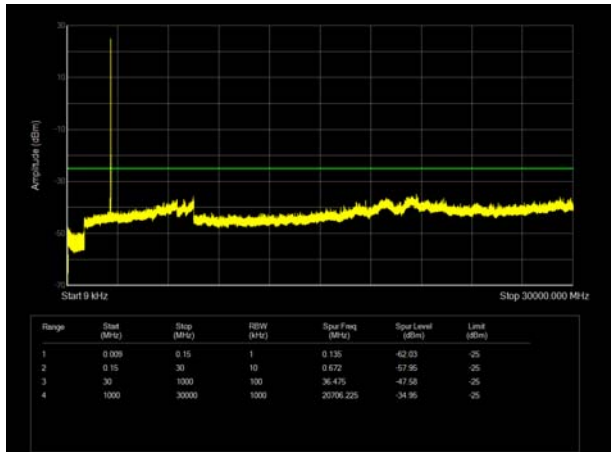

LTE Band 38 10MHz CH- Low 9kHz~30GHz

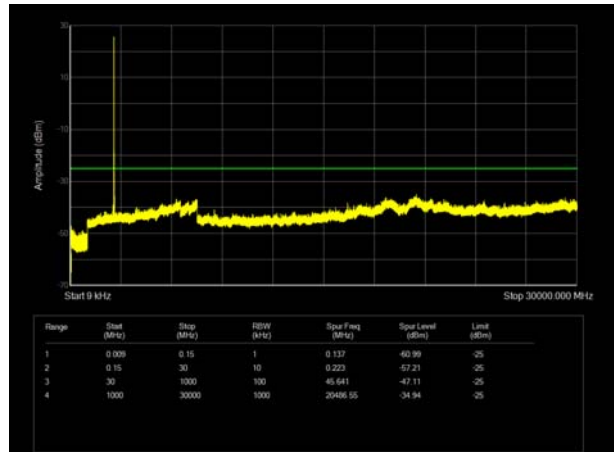

LTE Band 38 5MHz CH- Middle 9kHz~30GHz

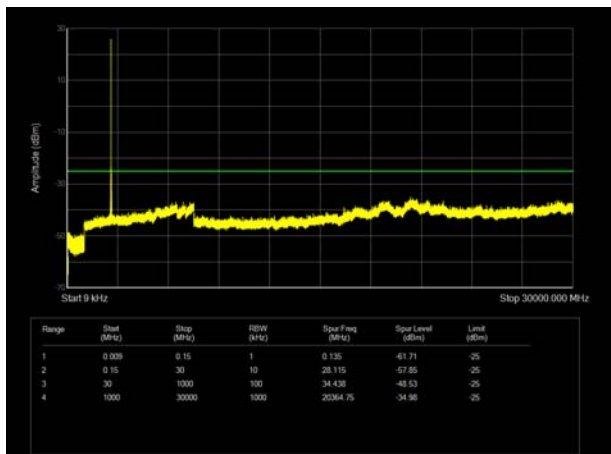

LTE Band 38 10MHz CH- Middle 9kHz~30GHz

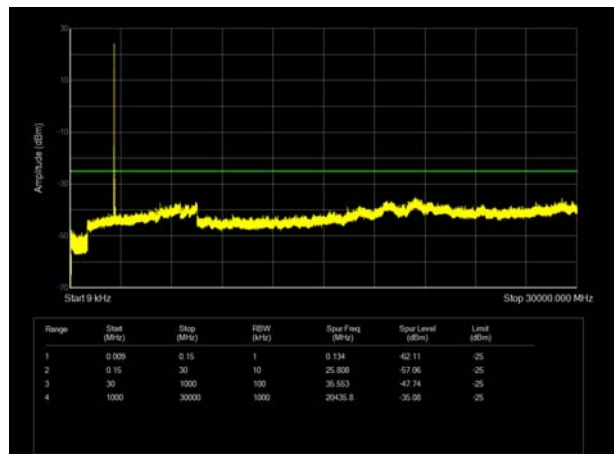

LTE Band 38 5MHz CH- High 9kHz~30GHz

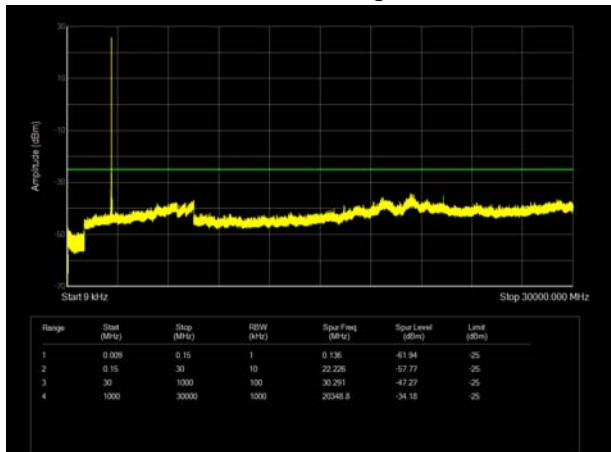

LTE Band 38 10MHz CH-High 9kHz~30GHz

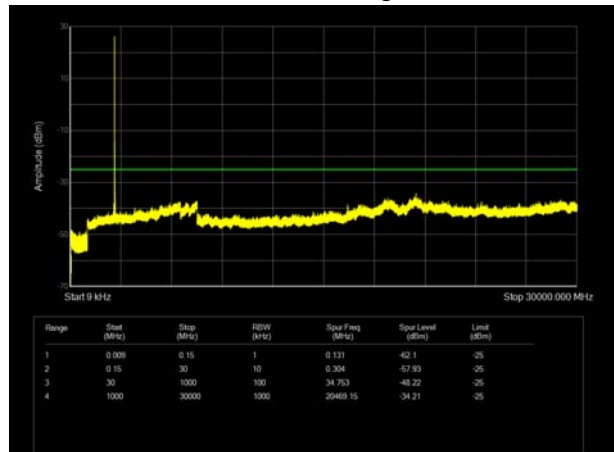



LTE Band 38 15MHz CH- Low 9kHz~30GHz

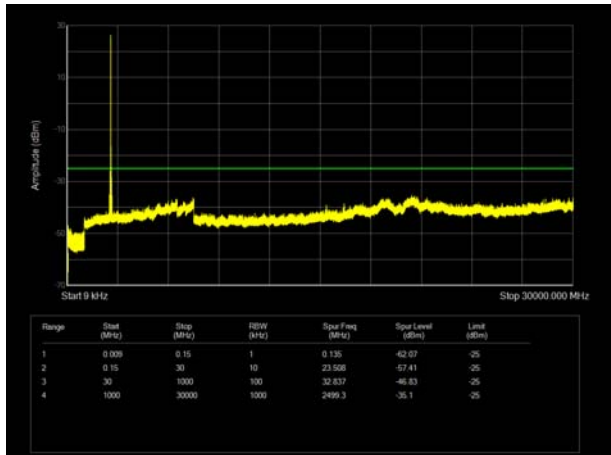

LTE Band 38 20MHz CH-Low 9kHz~30GHz

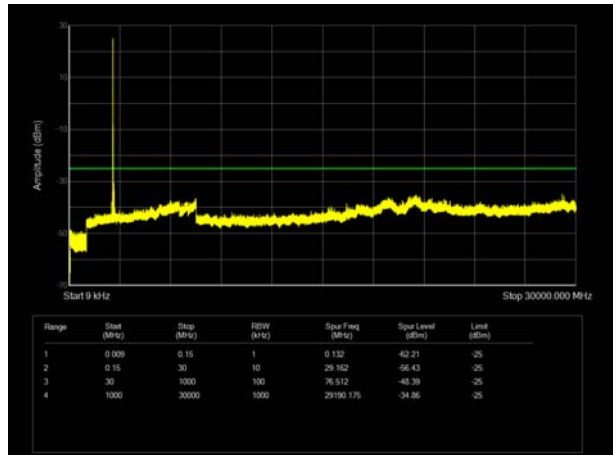

LTE Band 38 15MHz CH- Middle 9kHz~30GHz

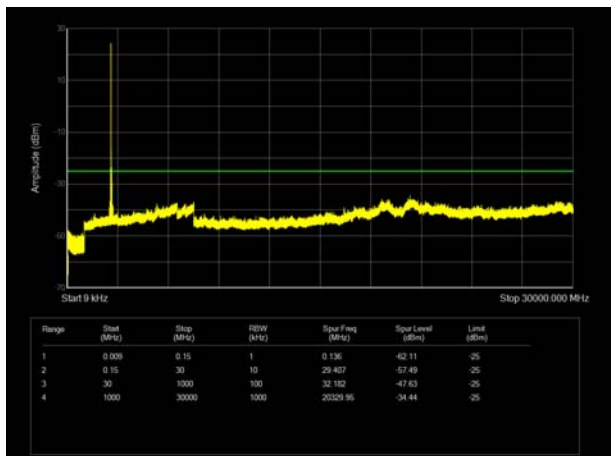

LTE Band 38 20MHz CH- Middle 9kHz~30GHz

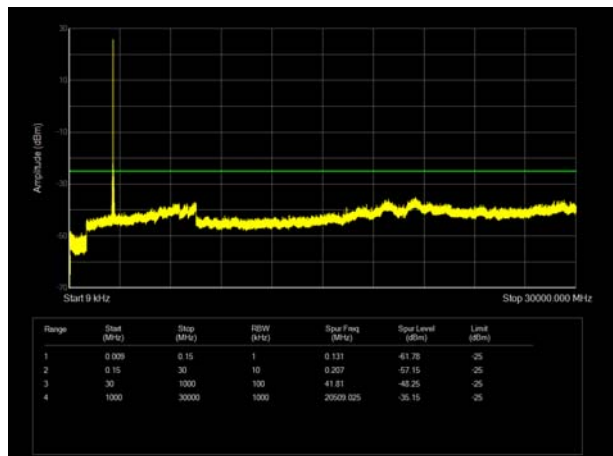

LTE Band 38 15MHz CH-High 9kHz~30GHz

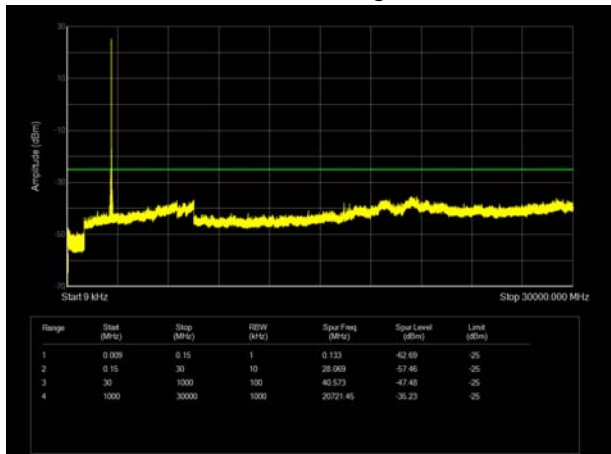

LTE Band 38 20MHz CH- High 9kHz~30GHz

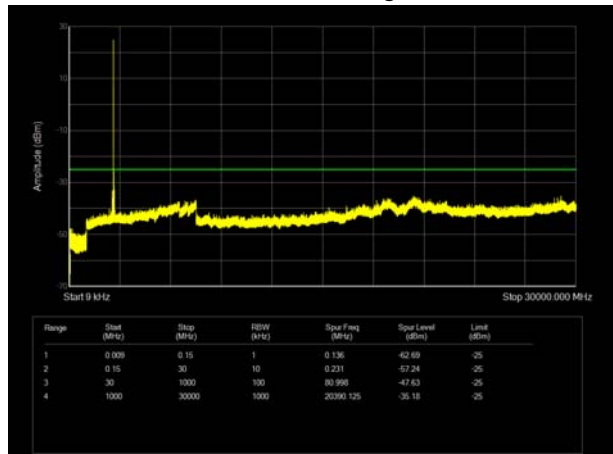

LTE Band 66 1.4MHz CH-Low 9kHz ~20GHz

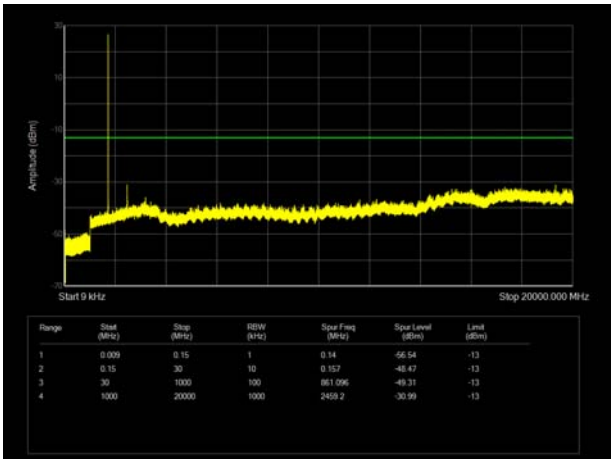

LTE Band 66 3MHz CH-Low 9kHz ~20GHz

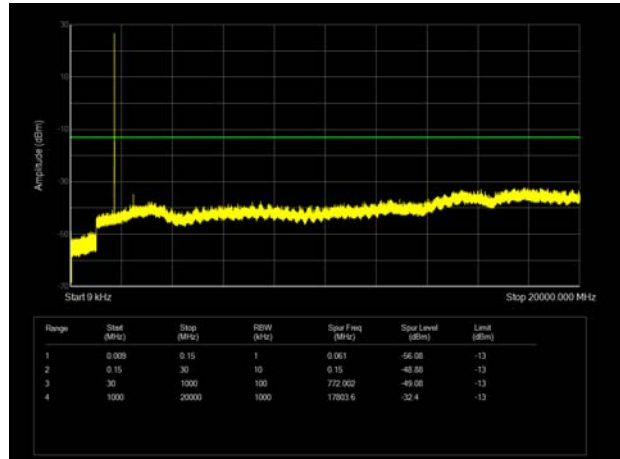

LTE Band 66 1.4MHz CH-Middle 9kHz ~20GHz

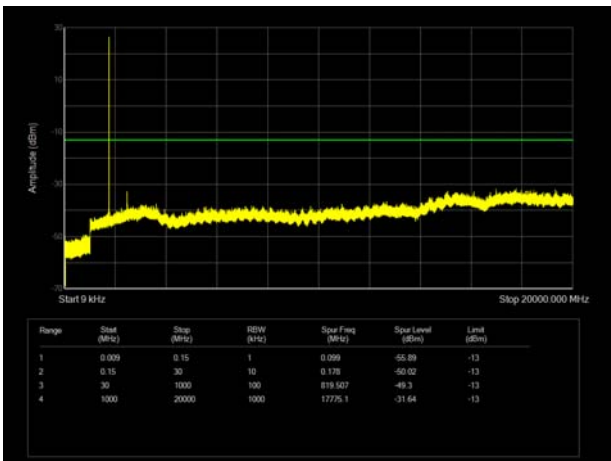

LTE Band 66 3MHz CH-Middle 9kHz ~20GHz

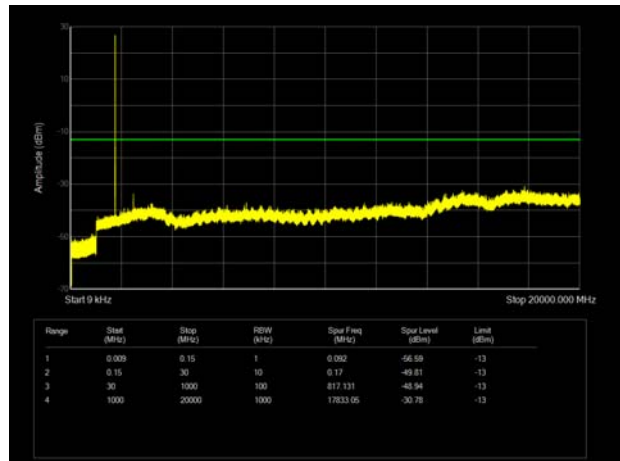

LTE Band 66 1.4MHz CH-High 9kHz ~20GHz

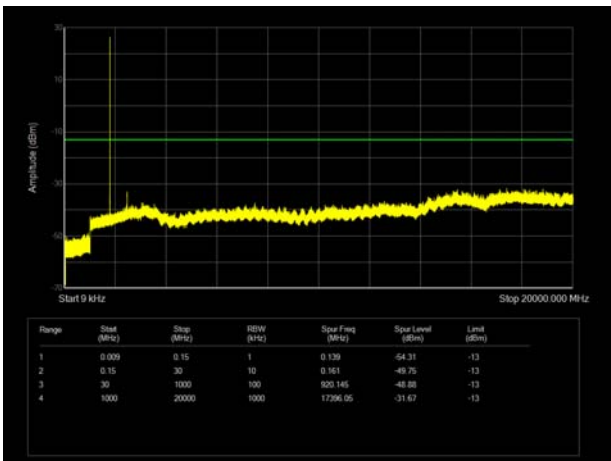

LTE Band 66 3MHz CH-High 9kHz ~20GHz

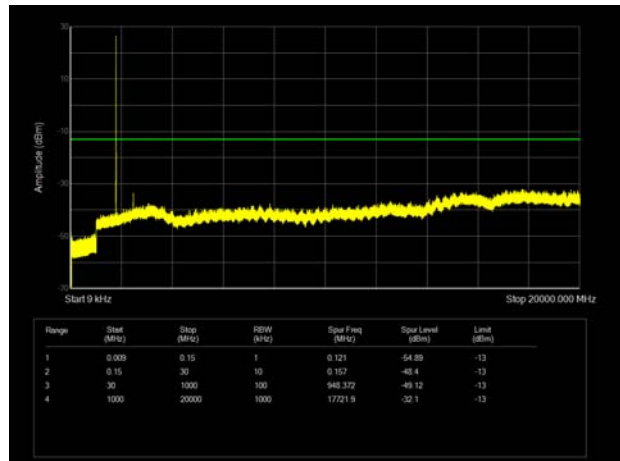

LTE Band 66 5MHz CH-Low 9kHz ~20GHz

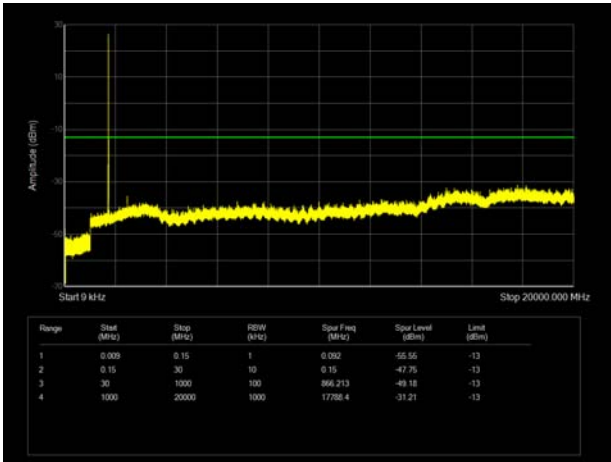

LTE Band 66 10MHz CH-Low 9kHz ~20GHz

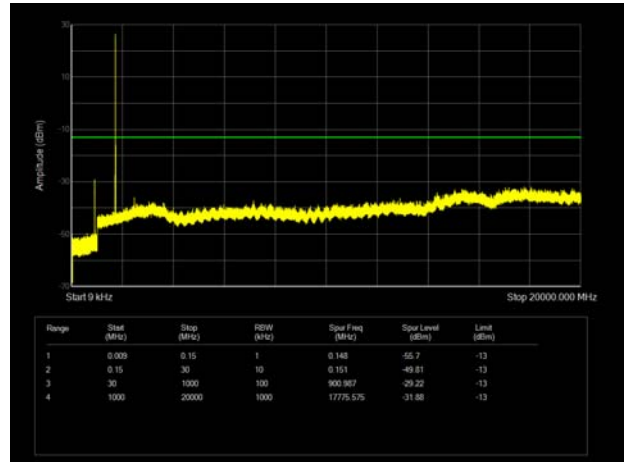

LTE Band 66 5MHz CH-Middle 9kHz ~20GHz

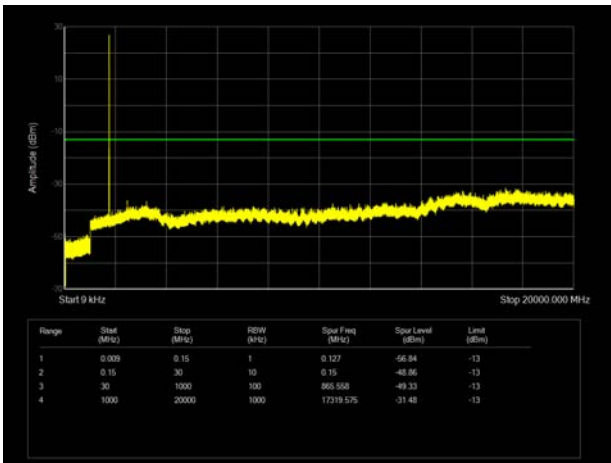

LTE Band 66 10MHz CH-Middle 9kHz ~20GHz

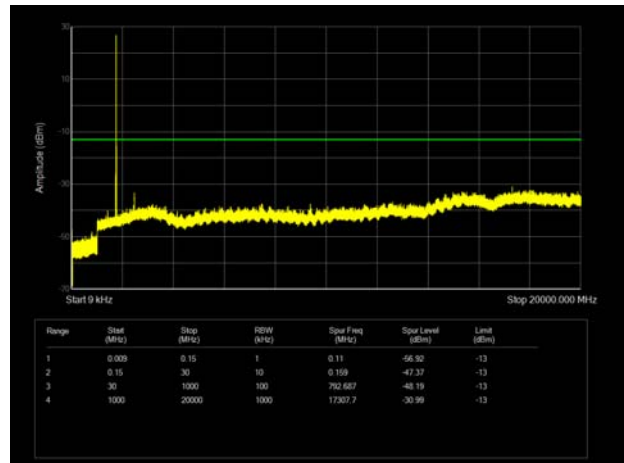

LTE Band 66 5MHz CH-High 9kHz ~20GHz

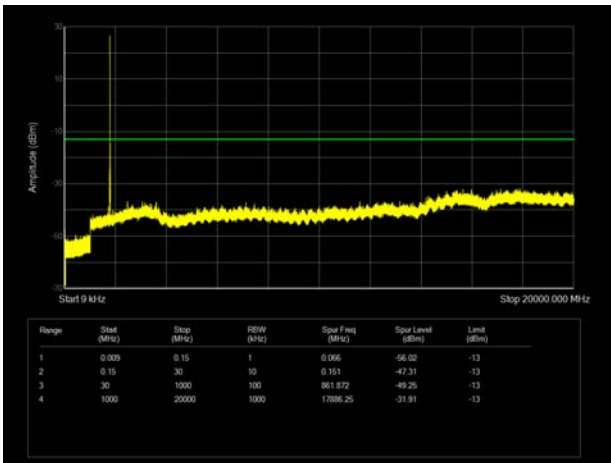

LTE Band 66 10MHz CH-High 9kHz ~20GHz

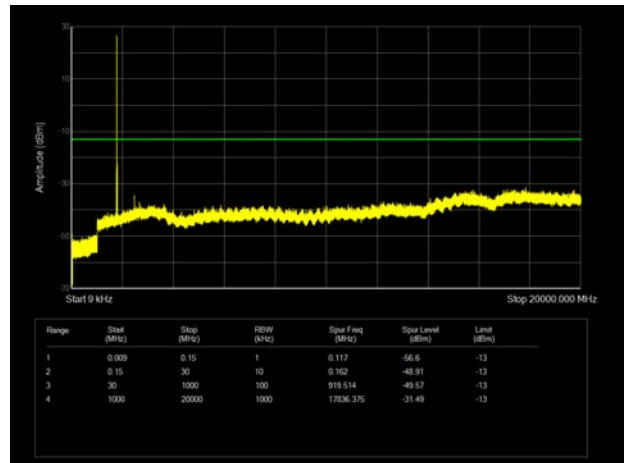

LTE Band 66 15MHz CH-Low 9kHz ~20GHz

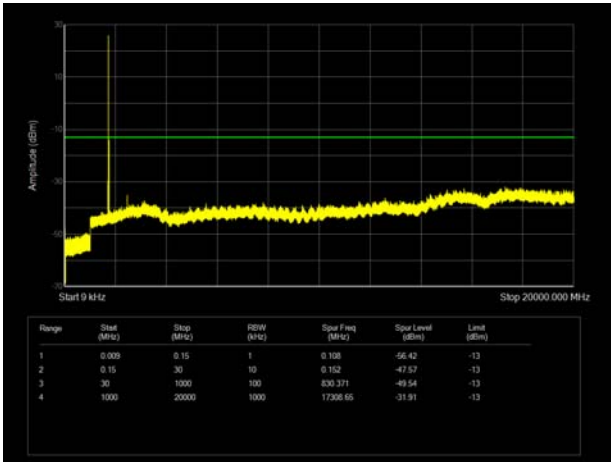

LTE Band 66 20MHz CH-Low 9kHz ~20GHz

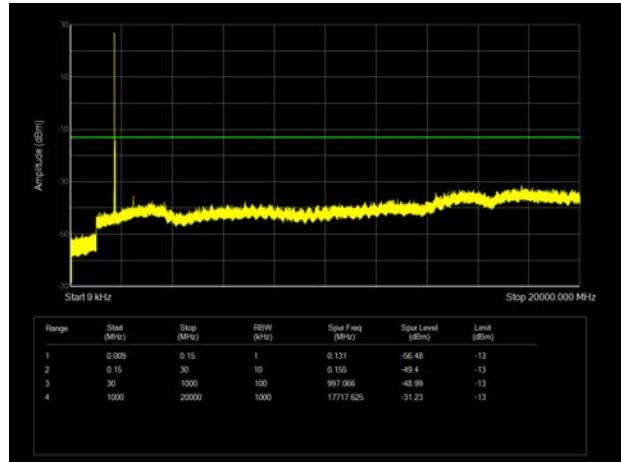

LTE Band 66 15MHz CH-Middle 9kHz ~20GHz

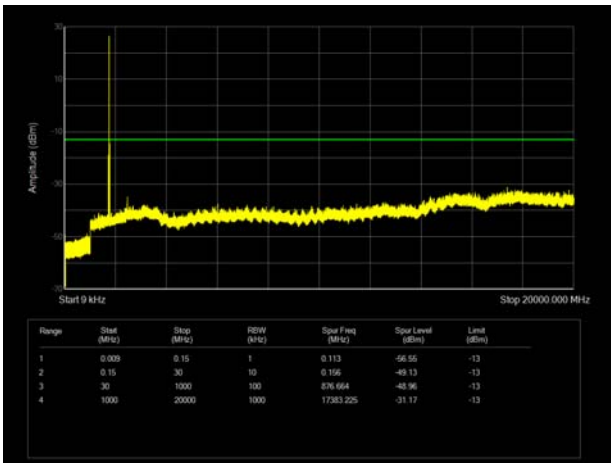

LTE Band 66 20MHz CH-Middle 9kHz ~20GHz

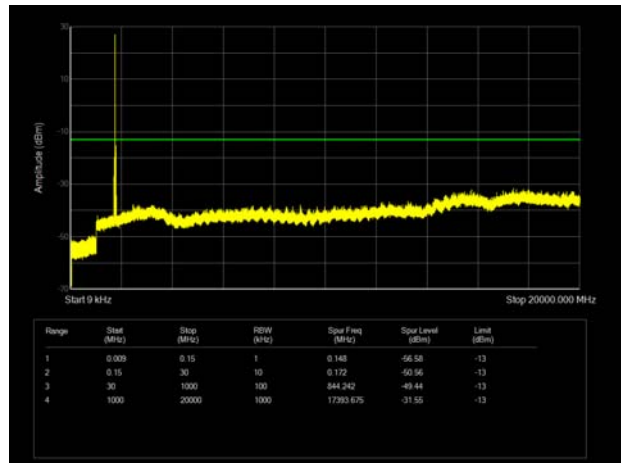

LTE Band 66 15MHz CH-High 9kHz ~20GHz

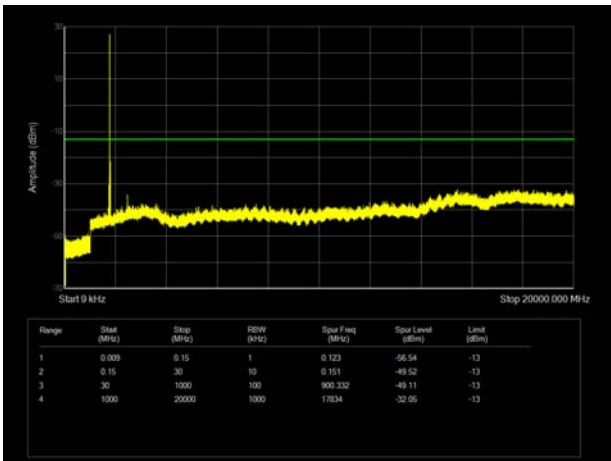

LTE Band 66 20MHz CH-High 9kHz ~20GHz

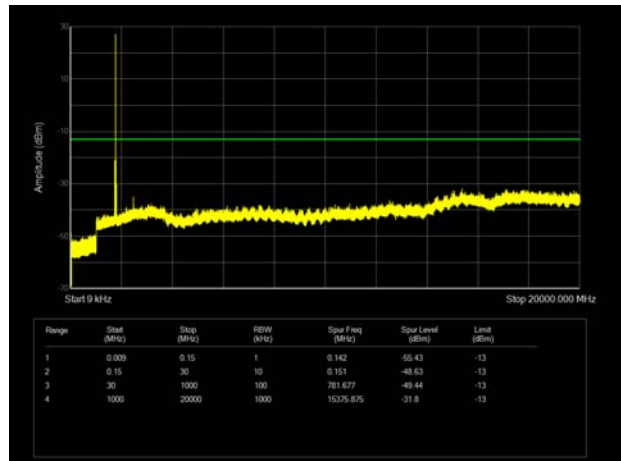

5.7 Radiates Spurious Emission

Ambient condition

Temperature	Relative humidity	Pressure
23°C ~25°C	45%~50%	101.5kPa

Method of Measurement

1. The testing follows FCC KDB 971168 D01 v03r01 Section 5.8 and ANSI C63.26 (2015).
2. Below 1GHz: The EUT is placed on a turntable 0.8 meters above the ground in the chamber, 3 meter away from the antenna. The maximal emission value is acquired by adjusting the antenna height, polarisation and turntable azimuth. Normally, the height range of antenna is 1 m to 4 m, the azimuth range of turntable is 0° to 360°, and the receive antenna has two polarizations Vertical (V) and Horizontal (H). Above 1GHz: (Note: the FCC's permission to use 1.5m as an alternative per TCBC Conf call of Dec. 2, 2014.) The EUT is placed on a turntable 1.5 meters above the ground in the chamber, 3 meter away from the antenna. The maximal emission value is acquired by adjusting the antenna height, polarisation and turntable azimuth. Normally, the height range of antenna is 1 m to 4 m, the azimuth range of turntable is 0° to 360°, and the receive antenna has two polarizations Vertical (V) and Horizontal (H).
3. A loop antenna, A log-periodic antenna or horn antenna shall be substituted in place of the EUT. The log-periodic antenna will be driven by a signal generator and the level will be adjusted till the same power value on the spectrum analyzer or receiver. The level of the spurious emissions can be calculated through the level of the signal generator, cable loss, the gain of the substitution antenna and the reading of the spectrum analyzer or receiver.
4. The EUT is then put into continuously transmitting mode at its maximum power level during the test. Set Test Receiver or Spectrum RBW=100kHz, VBW=300kHz for 30MHz to 1GHz and RBW=1MHz, VBW=3MHz for above 1GHz, and the maximum value of the receiver should be recorded as (Pr).
5. The EUT shall be replaced by a substitution antenna. In the chamber, an substitution antenna for the frequency band of interest is placed at the reference point of the chamber. An RF Signal source for the frequency band of interest is connected to the substitution antenna with a cable that has been constructed to not interfere with the radiation pattern of the antenna. A power (PMea) is applied to the input of the substitution antenna, and adjust the level of the signal generator output until the value of the receiver reach the previously recorded (Pr). The power of signal source (PMea) is recorded. The test should be performed by rotating the test item and adjusting the receiving antenna polarization.
6. A amplifier should be connected to the Signal Source output port. And the cable should be connect between the Amplifier and the Substitution Antenna. The cable loss (Pcl) ,the Substitution Antenna Gain (Ga) and the Amplifier Gain (PAg) should be recorded after test.
7. The measurement results are obtained as described below:
$$\text{Power(EIRP)} = \text{PMea} - \text{PAg} - \text{Pcl} + \text{Ga}$$

The measurement results are amend as described below:
$$\text{Power(EIRP)} = \text{PMea} - \text{Pcl} + \text{Ga}$$
8. This value is EIRP since the measurement is calibrated using an antenna of known gain (2.15 dB) and known input power. ERP can be calculated from EIRP by subtracting the gain of the dipole, $\text{ERP} = \text{EIRP} - 2.15\text{dB}$.

The modulation mode and RB allocation refer to section 5.1, using the maximum output power configuration.

Test setup

9KHz ~ 30MHz

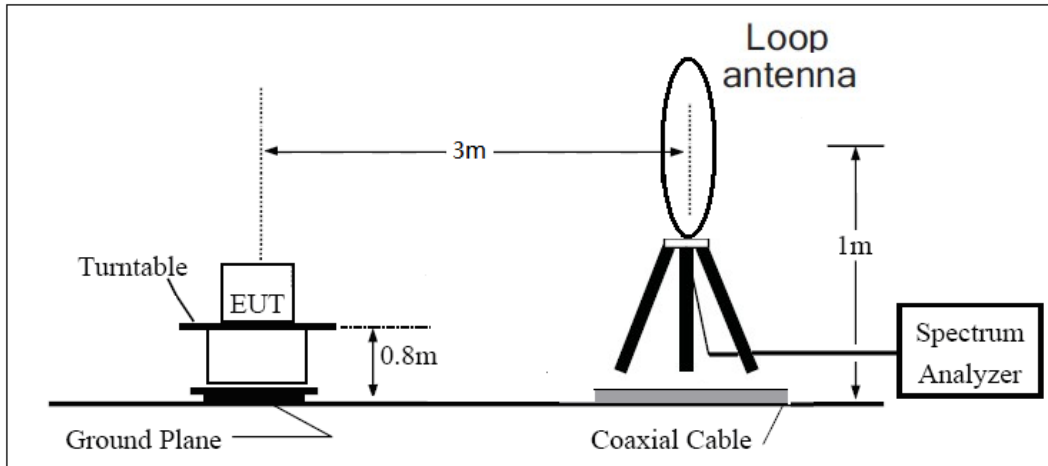

30MHz ~ 1GHz

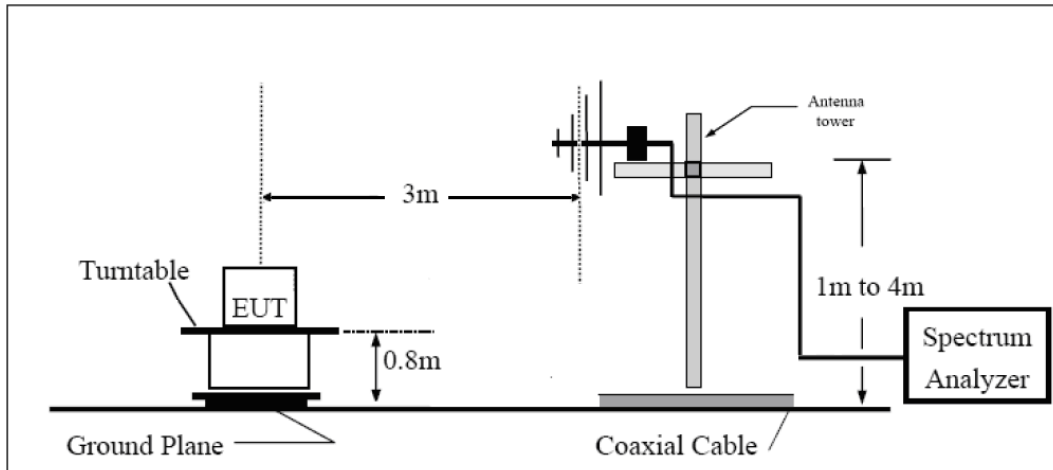

Above 1GHz

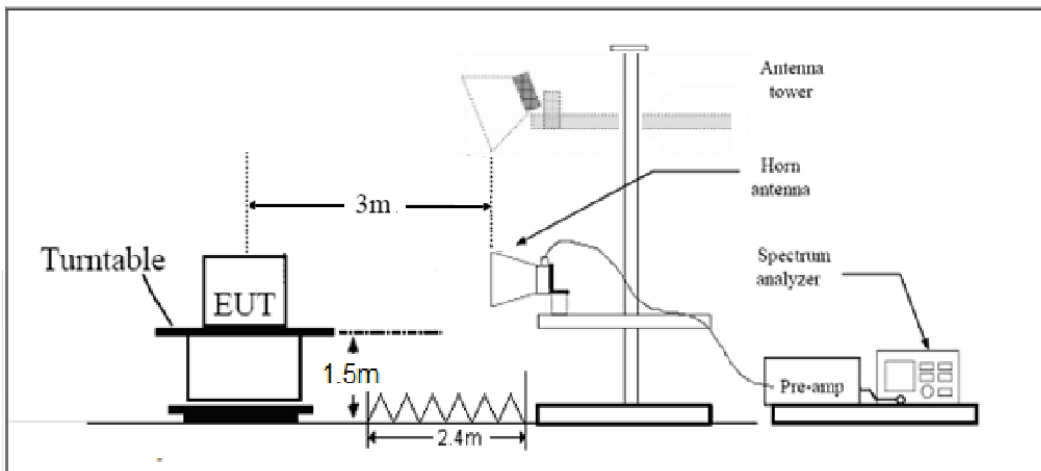

Note: Area side:2.4mX3.6m

Limits



Rule Part 27.53(h) specifies that “for operations in the 1695-1710 MHz, 1710-1755 MHz, 1755-1780 MHz, 1915-1920 MHz, 1995-2000 MHz, 2000-2020 MHz, 2110-2155 MHz, 2155-2180 MHz, and 2180-2200 bands, the power of any emission outside a licensee's frequency block shall be attenuated below the transmitter power (P) in watts by at least $43 + 10 \log_{10}(P)$ dB.”

Rule Part 27.53(m) $55 + 10 \log(P)$ dB on all frequencies more than X megahertz from the channel edge, where X is the greater of 6 megahertz or the actual emission bandwidth as defined in paragraph (m)(4) of this section.

Rule Part 27.53(f) For operations in the 746-758 MHz, 775-788 MHz, and 805-806 MHz bands, emissions in the band 1559-1610 MHz shall be limited to -70 dBW/MHz equivalent isotropically radiated power (EIRP) for wideband signals, and -80 dBW EIRP for discrete emissions of less than 700 Hz bandwidth. For the purpose of equipment authorization, a transmitter shall be tested with an antenna that is representative of the type that will be used with the equipment in normal operation.

Part 27.53 (c) For operations in the 746-758 MHz band and the 776-788 MHz band, the power of any emission outside the licensee's frequency band(s) of operation shall be attenuated below the transmitter power (P) within the licensed band(s) of operation, measured in watts, in accordance with the following:

- (1) On any frequency outside the 746-758 MHz band, the power of any emission shall be attenuated outside the band below the transmitter power (P) by at least $43 + 10 \log(P)$ dB;
- (2) On any frequency outside the 776-788 MHz band, the power of any emission shall be attenuated outside the band below the transmitter power (P) by at least $43 + 10 \log(P)$ dB;
- (3) On all frequencies between 763-775 MHz and 793-805 MHz, by a factor not less than $76 + 10 \log(P)$ dB in a 6.25 kHz band segment, for base and fixed stations;
- (4) On all frequencies between 763-775 MHz and 793-805 MHz, by a factor not less than $65 + 10 \log(P)$ dB in a 6.25 kHz band segment, for mobile and portable stations;
- (5) Compliance with the provisions of paragraphs (c)(1) and (c)(2) of this section is based on the use of measurement instrumentation employing a resolution bandwidth of 100 kHz or greater. However, in the 100 kHz bands immediately outside and adjacent to the frequency block, a resolution bandwidth of at least 30 kHz may be employed;

Part 27.53(h) Limit		-13 dBm
Part 27.53(f) Limit	Limit out of the band 1559-1610 MHz	-13 dBm
	Limit in the band 1559-1610 MHz	-40 dBm
Part 27.53(m) Limit		-25 dBm

Measurement Uncertainty

The assessed measurement uncertainty to ensure 95% confidence level for the normal distribution is with the coverage factor $k = \pm 1.96$, $U = \pm 3.55$ dB.

**Test Result**

Sweep the whole frequency band through the range from 9kHz to the 10th harmonic of the carrier, the emissions below the noise floor will not be recorded in the report.

Main Antenna

WCDMA Band IV CH-Middle

Harmonic	Frequency (MHz)	SG (dBm)	Cable Loss (dB)	Gain (dBi)	Antenna Polarization	EIRP Level (dBm)	Limit (dBm)	Margin (dB)	Azimuth (deg)
2	3465.20	-66.33	2.70	12.70	Horizontal	-56.33	-13.00	43.33	90
3	5197.80	-62.22	3.20	12.50	Horizontal	-52.92	-13.00	39.92	0
4	6930.40	-61.40	4.20	11.80	Horizontal	-53.80	-13.00	40.80	225
5	8663.00	-56.14	4.40	12.50	Horizontal	-48.04	-13.00	35.04	180
6	10395.60	-49.37	4.70	11.30	Horizontal	-42.77	-13.00	29.77	180
7	12128.20	-52.00	5.20	13.80	Horizontal	-43.40	-13.00	30.40	180
8	13860.80	-49.16	5.70	11.30	Horizontal	-43.56	-13.00	30.56	270
9	15593.40	-52.99	6.10	16.80	Horizontal	-42.29	-13.00	29.29	135
10	17326.00	-48.62	6.10	14.20	Horizontal	-40.52	-13.00	27.52	225

Note: 1.The other Spurious RF Radiated emissions level is no more than noise floor.

2. The worst emission was found in the antenna is Horizontal position.

LTE Band 4 QPSK 1.4MHz CH-Middle, RB 1

Harmonic	Frequency (MHz)	SG (dBm)	Cable Loss (dB)	Gain (dBi)	Antenna Polarization	EIRP Level (dBm)	Limit (dBm)	Margin (dB)	Azimuth (deg)
2	3464.25	-65.84	2.70	12.70	Horizontal	-55.84	-13.00	42.84	315
3	5197.50	-60.91	3.20	12.50	Horizontal	-51.61	-13.00	38.61	135
4	6930.00	-61.55	4.20	11.80	Horizontal	-53.95	-13.00	40.95	270
5	8662.50	-55.63	4.40	12.50	Horizontal	-47.53	-13.00	34.53	90
6	10395.00	-50.07	4.70	11.30	Horizontal	-43.47	-13.00	30.47	0
7	12127.50	-52.23	5.20	13.80	Horizontal	-43.63	-13.00	30.63	225
8	13860.00	-50.23	5.70	11.30	Horizontal	-44.63	-13.00	31.63	45
9	15592.50	-52.98	6.10	16.80	Horizontal	-42.28	-13.00	29.28	45
10	17325.00	-49.47	6.10	14.20	Horizontal	-41.37	-13.00	28.37	315

Note: 1.The other Spurious RF Radiated emissions level is no more than noise floor.

2. The worst emission was found in the antenna is Horizontal position.



LTE Band 4 QPSK 5MHz CH-Middle, RB 1

Harmonic	Frequency (MHz)	SG (dBm)	Cable Loss (dB)	Gain (dBi)	Antenna Polarization	EIRP Level (dBm)	Limit (dBm)	Margin (dB)	Azimuth (deg)
2	3460.50	-65.71	2.70	12.70	Horizontal	-55.71	-13.00	42.71	180
3	5191.50	-60.22	3.20	12.50	Horizontal	-50.92	-13.00	37.92	180
4	6930.00	-61.99	4.20	11.80	Horizontal	-54.39	-13.00	41.39	45
5	8662.50	-55.09	4.40	12.50	Horizontal	-46.99	-13.00	33.99	270
6	10395.00	-50.13	4.70	11.30	Horizontal	-43.53	-13.00	30.53	270
7	12127.50	-52.49	5.20	13.80	Horizontal	-43.89	-13.00	30.89	45
8	13860.00	-49.90	5.70	11.30	Horizontal	-44.30	-13.00	31.30	225
9	15592.50	-53.44	6.10	16.80	Horizontal	-42.74	-13.00	29.74	270
10	17325.00	-48.48	6.10	14.20	Horizontal	-40.38	-13.00	27.38	315

Note: 1. The other Spurious RF Radiated emissions level is no more than noise floor.

2. The worst emission was found in the antenna is Horizontal position.

LTE Band 4 QPSK 20MHz CH-Middle, RB 1

Harmonic	Frequency (MHz)	SG (dBm)	Cable Loss (dB)	Gain (dBi)	Antenna Polarization	EIRP Level (dBm)	Limit (dBm)	Margin (dB)	Azimuth (deg)
2	3465.00	-66.88	2.70	12.70	Horizontal	-56.88	-13.00	43.88	270
3	5170.88	-60.44	3.20	12.50	Horizontal	-51.14	-13.00	38.14	0
4	6930.00	-61.77	4.20	11.80	Horizontal	-54.17	-13.00	41.17	315
5	8662.50	-56.31	4.40	12.50	Horizontal	-48.21	-13.00	35.21	225
6	10395.00	-49.30	4.70	11.30	Horizontal	-42.70	-13.00	29.70	135
7	12127.50	-51.79	5.20	13.80	Horizontal	-43.19	-13.00	30.19	180
8	13860.00	-50.05	5.70	11.30	Horizontal	-44.45	-13.00	31.45	315
9	15592.50	-53.07	6.10	16.80	Horizontal	-42.37	-13.00	29.37	180
10	17325.00	-50.15	6.10	14.20	Horizontal	-42.05	-13.00	29.05	315

Note: 1. The other Spurious RF Radiated emissions level is no more than noise floor.

2. The worst emission was found in the antenna is Horizontal position.



LTE Band 7 QPSK 5MHz CH-Middle, RB 1

Harmonic	Frequency (MHz)	SG (dBm)	Cable Loss (dB)	Gain (dBi)	Antenna Polarization	EIRP Level (dBm)	Limit (dBm)	Margin (dB)	Azimuth (deg)
2	5065.80	-60.36	3.40	12.50	Horizontal	-51.26	-25.00	26.26	225
3	7598.60	-57.06	4.40	12.20	Horizontal	-49.26	-25.00	24.26	45
4	10130.63	-51.16	4.70	11.30	Horizontal	-44.56	-25.00	19.56	0
5	12675.00	-52.33	5.40	13.20	Horizontal	-44.53	-25.00	19.53	135
6	15210.00	-48.38	6.10	13.10	Horizontal	-41.38	-25.00	16.38	225
7	17745.00	-51.11	6.10	14.20	Horizontal	-43.01	-25.00	18.01	225
8	20280.00	--	--	--	--	--	--	--	--
9	22815.00	--	--	--	--	--	--	--	--
10	25350.00	--	--	--	--	--	--	--	--

Note: 1. The other Spurious RF Radiated emissions level is no more than noise floor.

2. The worst emission was found in the antenna is Horizontal position.

LTE Band 7 QPSK 20MHz CH-Middle, RB 1

Harmonic	Frequency (MHz)	SG (dBm)	Cable Loss (dB)	Gain (dBi)	Antenna Polarization	EIRP Level (dBm)	Limit (dBm)	Margin (dB)	Azimuth (deg)
2	5052.38	-60.59	3.40	12.50	Horizontal	-51.49	-25.00	26.49	45
3	7578.00	-57.73	4.40	12.20	Horizontal	-49.93	-25.00	24.93	0
4	10104.00	-52.66	4.70	11.30	Horizontal	-46.06	-25.00	21.06	45
5	12675.00	-51.17	5.40	13.20	Horizontal	-43.37	-25.00	18.37	180
6	15210.00	-48.23	6.10	13.10	Horizontal	-41.23	-25.00	16.23	315
7	17745.00	-50.66	6.10	14.20	Horizontal	-42.56	-25.00	17.56	45
8	20280.00	--	--	--	--	/	-25.00	/	/
9	22815.00	--	--	--	--	/	-25.00	/	/
10	25350.00	--	--	--	--	/	-25.00	/	/

Note: 1. The other Spurious RF Radiated emissions level is no more than noise floor.

2. The worst emission was found in the antenna is Horizontal position.



LTE Band 13 QPSK 5MHz CH-Middle, RB 1

Harmonic	Frequency (MHz)	SG (dBm)	Cable Loss (dB)	Gain (dBi)	Antenna Polarization	EIRP Level (dBm)	Limit (dBm)	Margin (dB)	Azimuth (deg)
2	1559.80	-75.35	3.40	12.50	Horizontal	-66.25	-40.00	26.25	45
Harmonic	Frequency (MHz)	SG (dBm)	Cable Loss (dB)	Gain (dBi)	Antenna Polarization	ERP Level (dBm)	Limit (dBm)	Margin (dB)	Azimuth (deg)
3	2339.60	-64.09	2.10	11.10	Horizontal	-57.24	-13.00	44.24	135
4	3128.00	-64.53	2.30	13.10	Horizontal	-55.88	-13.00	42.88	0
5	3910.00	-63.48	2.60	12.70	Horizontal	-55.53	-13.00	42.53	45
6	4692.00	-60.11	3.30	12.50	Horizontal	-53.06	-13.00	40.06	225
7	5474.00	-58.56	3.40	12.50	Horizontal	-51.61	-13.00	38.61	0
8	6256.00	-60.20	3.30	12.50	Horizontal	-53.15	-13.00	40.15	45
9	7038.00	-57.16	3.80	11.50	Horizontal	-51.61	-13.00	38.61	135
10	7820.00	-55.13	4.20	11.80	Horizontal	-49.68	-13.00	36.68	45

Note: 1.The other Spurious RF Radiated emissions level is no more than noise floor.

2. The worst emission was found in the antenna is Horizontal position.

LTE Band 13 QPSK 10MHz CH-Middle, RB 1

Harmonic	Frequency (MHz)	SG (dBm)	Cable Loss (dB)	Gain (dBi)	Antenna Polarization	EIRP Level (dBm)	Limit (dBm)	Margin (dB)	Azimuth (deg)
2	1555.53	-73.35	3.40	12.50	Horizontal	-64.25	-40.00	24.25	135
Harmonic	Frequency (MHz)	SG (dBm)	Cable Loss (dB)	Gain (dBi)	Antenna Polarization	ERP Level (dBm)	Limit (dBm)	Margin (dB)	Azimuth (deg)
3	3128.00	-62.87	2.10	11.10	Horizontal	-56.02	-13.00	43.02	45
4	3910.00	-64.03	2.30	13.10	Horizontal	-55.38	-13.00	42.38	225
5	4692.00	-62.14	2.60	12.70	Horizontal	-54.19	-13.00	41.19	0
6	5474.00	-59.52	3.30	12.50	Horizontal	-52.47	-13.00	39.47	45
7	6256.00	-59.92	3.40	12.50	Horizontal	-52.97	-13.00	39.97	0
8	7038.00	-58.30	3.30	12.50	Horizontal	-51.25	-13.00	38.25	45
9	7820.00	-55.41	3.80	11.50	Horizontal	-49.86	-13.00	36.86	225
10	3128.00	-61.47	4.20	11.80	Horizontal	-56.02	-13.00	43.02	45

Note: 1.The other Spurious RF Radiated emissions level is no more than noise floor.

2. The worst emission was found in the antenna is Horizontal position.



LTE Band 38 QPSK 5MHz CH-Middle, RB 1

Harmonic	Frequency (MHz)	SG (dBm)	Cable Loss (dB)	Gain (dBi)	Antenna Polarization	EIRP Level (dBm)	Limit (dBm)	Margin (dB)	Azimuth (deg)
2	5185.00	-61.83	3.20	12.50	Horizontal	-52.53	-25.00	27.53	225
3	7777.50	-59.18	4.40	12.30	Horizontal	-51.28	-25.00	26.28	45
4	10370.00	-52.96	4.70	11.80	Horizontal	-45.86	-25.00	20.86	270
5	12962.50	-52.95	5.40	14.00	Horizontal	-44.35	-25.00	19.35	0
6	15555.00	-54.78	6.10	16.80	Horizontal	-44.08	-25.00	19.08	225
7	18147.50	--	--	--	--	/	-25.00	/	/
8	20740.00	--	--	--	--	/	-25.00	/	/
9	23332.50	--	--	--	--	/	-25.00	/	/
10	25925.00	--	--	--	--	/	-25.00	/	/

Note: 1. The other Spurious RF Radiated emissions level is no more than noise floor.

2. The worst emission was found in the antenna is Horizontal position.

LTE Band 38 QPSK 20MHz CH-Middle, RB 1

Harmonic	Frequency (MHz)	SG (dBm)	Cable Loss (dB)	Gain (dBi)	Antenna Polarization	EIRP Level (dBm)	Limit (dBm)	Margin (dB)	Azimuth (deg)
2	5170.00	-61.35	3.20	12.50	Horizontal	-52.05	-25.00	27.05	315
3	7755.00	-58.12	4.40	12.30	Horizontal	-50.22	-25.00	25.22	270
4	10340.00	-51.48	4.70	11.80	Horizontal	-44.38	-25.00	19.38	45
5	12925.00	-53.46	5.40	14.00	Horizontal	-44.86	-25.00	19.86	315
6	15510.00	-54.44	6.10	16.80	Horizontal	-43.74	-25.00	18.74	315
7	18095.00	--	--	--	--	/	-25.00	/	/
8	20680.00	--	--	--	--	/	-25.00	/	/
9	23265.00	--	--	--	--	/	-25.00	/	/
10	25850.00	--	--	--	--	/	-25.00	/	/

Note: 1. The other Spurious RF Radiated emissions level is no more than noise floor.

2. The worst emission was found in the antenna is Horizontal position.



LTE Band 66 QPSK 1.4MHz CH-Middle, RB 1

Harmonic	Frequency (MHz)	SG (dBm)	Cable Loss (dB)	Gain (dBi)	Antenna Polarization	EIRP Level (dBm)	Limit (dBm)	Margin (dB)	Azimuth (deg)
2	3464.30	-67.11	2.70	12.70	Horizontal	-57.11	-13.00	44.11	180
3	5197.50	-60.77	3.20	12.50	Horizontal	-51.47	-13.00	38.47	315
4	6930.00	-62.25	4.20	11.80	Horizontal	-54.65	-13.00	41.65	180
5	8662.50	-56.39	4.40	12.50	Horizontal	-48.29	-13.00	35.29	45
6	10395.00	-51.99	4.70	11.80	Horizontal	-44.89	-13.00	31.89	0
7	12127.50	-51.86	5.20	13.80	Horizontal	-43.26	-13.00	30.26	180
8	13860.00	-51.73	5.70	13.20	Horizontal	-44.23	-13.00	31.23	270
9	15592.50	-53.22	6.10	16.80	Horizontal	-42.52	-13.00	29.52	90
10	17325.00	-50.25	6.10	14.20	Horizontal	-42.15	-13.00	29.15	135

Note: 1. The other Spurious RF Radiated emissions level is no more than noise floor.
2. The worst emission was found in the antenna is Horizontal position.

LTE Band 66 QPSK 5MHz CH-Middle, RB 1

Harmonic	Frequency (MHz)	SG (dBm)	Cable Loss (dB)	Gain (dBi)	Antenna Polarization	EIRP Level (dBm)	Limit (dBm)	Margin (dB)	Azimuth (deg)
2	3460.50	-65.47	2.70	12.70	Horizontal	-55.47	-13.00	42.47	315
3	5191.50	-60.80	3.20	12.50	Horizontal	-51.50	-13.00	38.50	0
4	6930.00	-62.82	4.20	11.80	Horizontal	-55.22	-13.00	42.22	270
5	8662.50	-56.43	4.40	12.50	Horizontal	-48.33	-13.00	35.33	225
6	10395.00	-51.80	4.70	11.80	Horizontal	-44.70	-13.00	31.70	180
7	12127.50	-53.23	5.20	13.80	Horizontal	-44.63	-13.00	31.63	135
8	13860.00	-51.76	5.70	13.20	Horizontal	-44.26	-13.00	31.26	0
9	15592.50	-53.86	6.10	16.80	Horizontal	-43.16	-13.00	30.16	180
10	17325.00	-50.35	6.10	14.20	Horizontal	-42.25	-13.00	29.25	270

Note: 1. The other Spurious RF Radiated emissions level is no more than noise floor.
2. The worst emission was found in the antenna is Horizontal position.



LTE Band 66 QPSK 20MHz CH-Middle, RB 1

Harmonic	Frequency (MHz)	SG (dBm)	Cable Loss (dB)	Gain (dBi)	Antenna Polarization	EIRP Level (dBm)	Limit (dBm)	Margin (dB)	Azimuth (deg)
2	3747.00	-64.20	2.70	12.70	Horizontal	-54.20	-13.00	41.20	0
3	5170.50	-61.79	3.20	12.50	Horizontal	-52.49	-13.00	39.49	135
4	6930.00	-62.04	4.20	11.80	Horizontal	-54.44	-13.00	41.44	45
5	8662.50	-57.49	4.40	12.50	Horizontal	-49.39	-13.00	36.39	315
6	10395.00	-51.81	4.70	11.80	Horizontal	-44.71	-13.00	31.71	225
7	12127.50	-52.81	5.20	13.80	Horizontal	-44.21	-13.00	31.21	270
8	13860.00	-52.14	5.70	13.20	Horizontal	-44.64	-13.00	31.64	180
9	15592.50	-54.03	6.10	16.80	Horizontal	-43.33	-13.00	30.33	180
10	17325.00	-49.92	6.10	14.20	Horizontal	-41.82	-13.00	28.82	135

Note: 1. The other Spurious RF Radiated emissions level is no more than noise floor.

2. The worst emission was found in the antenna is Horizontal position.

**Second Antenna**

WCDMA Band IV CH-Middle

Harmonic	Frequency (MHz)	SG (dBm)	Cable Loss (dB)	Gain (dBi)	Antenna Polarization	EIRP Level (dBm)	Limit (dBm)	Margin (dB)	Azimuth (deg)
2	3465.20	46.57	2.70	12.70	Horizontal	56.57	13.00	43.57	45.00
3	5197.80	43.34	3.20	12.50	Horizontal	52.64	13.00	39.64	225.00
4	6930.40	46.90	4.20	11.80	Horizontal	54.50	13.00	41.50	90.00
5	8663.00	40.00	4.40	12.50	Horizontal	48.10	13.00	35.10	45.00
6	10395.60	37.66	4.70	11.30	Horizontal	44.26	13.00	31.26	135.00
7	12128.20	36.49	5.20	13.80	Horizontal	45.09	13.00	32.09	180.00
8	13860.80	39.22	5.70	11.30	Horizontal	44.82	13.00	31.82	90.00
9	15593.40	32.36	6.10	16.80	Horizontal	43.06	13.00	30.06	315.00
10	17326.00	33.15	6.10	14.20	Horizontal	41.25	13.00	28.25	45.00

Note: 1. The other Spurious RF Radiated emissions level is no more than noise floor.

2. The worst emission was found in the antenna is Horizontal position.

LTE Band 4 QPSK 1.4MHz CH-Middle, RB 1

Harmonic	Frequency (MHz)	SG (dBm)	Cable Loss (dB)	Gain (dBi)	Antenna Polarization	EIRP Level (dBm)	Limit (dBm)	Margin (dB)	Azimuth (deg)
2	3464.25	46.35	2.70	12.70	Vertical	56.35	13.00	43.35	315.00
3	5197.50	43.04	3.20	12.50	Vertical	52.34	13.00	39.34	90.00
4	6930.00	39.66	4.20	11.80	Vertical	47.26	13.00	34.26	45.00
5	8662.50	36.27	4.40	12.50	Vertical	44.37	13.00	31.37	135.00
6	10395.00	37.75	4.70	11.30	Vertical	44.35	13.00	31.35	270.00
7	12127.50	34.66	5.20	13.80	Vertical	43.26	13.00	30.26	90.00
8	13860.00	38.68	5.70	11.30	Vertical	44.28	13.00	31.28	45.00
9	15592.50	31.10	6.10	16.80	Vertical	41.80	13.00	28.80	315.00
10	17325.00	32.42	6.10	14.20	Vertical	40.52	13.00	27.52	180.00

Note: 1. The other Spurious RF Radiated emissions level is no more than noise floor.

2. The worst emission was found in the antenna is Vertical position.



LTE Band 4 QPSK 5MHz CH-Middle, RB 1

Harmonic	Frequency (MHz)	SG (dBm)	Cable Loss (dB)	Gain (dBi)	Antenna Polarization	EIRP Level (dBm)	Limit (dBm)	Margin (dB)	Azimuth (deg)
2	3460.50	46.17	2.70	12.70	Vertical	56.17	13.00	43.17	90.00
3	5191.50	43.03	3.20	12.50	Vertical	52.33	13.00	39.33	135.00
4	6930.00	46.33	4.20	11.80	Vertical	53.93	13.00	40.93	225.00
5	8662.50	39.73	4.40	12.50	Vertical	47.83	13.00	34.83	0.00
6	10395.00	37.77	4.70	11.30	Vertical	44.37	13.00	31.37	45.00
7	12127.50	34.65	5.20	13.80	Vertical	43.25	13.00	30.25	45.00
8	13860.00	38.68	5.70	11.30	Vertical	44.28	13.00	31.28	90.00
9	15592.50	31.10	6.10	16.80	Vertical	41.80	13.00	28.80	315.00
10	17325.00	32.42	6.10	14.20	Vertical	40.52	13.00	27.52	180.00

Note: 1. The other Spurious RF Radiated emissions level is no more than noise floor.
2. The worst emission was found in the antenna is Vertical position.

LTE Band 4 QPSK 20MHz CH-Middle, RB 1

Harmonic	Frequency (MHz)	SG (dBm)	Cable Loss (dB)	Gain (dBi)	Antenna Polarization	EIRP Level (dBm)	Limit (dBm)	Margin (dB)	Azimuth (deg)
2	3465.00	46.33	2.70	12.70	Vertical	56.33	13.00	43.33	0.00
3	5170.88	42.95	3.20	12.50	Vertical	52.25	13.00	39.25	90.00
4	6930.00	46.09	4.20	11.80	Vertical	53.69	13.00	40.69	45.00
5	8662.50	39.25	4.40	12.50	Vertical	47.35	13.00	34.35	315.00
6	10395.00	37.66	4.70	11.30	Vertical	44.26	13.00	31.26	45.00
7	12127.50	34.65	5.20	13.80	Vertical	43.25	13.00	30.25	180.00
8	13860.00	36.38	5.70	11.30	Vertical	41.98	13.00	28.98	90.00
9	15592.50	29.63	6.10	16.80	Vertical	40.33	13.00	27.33	45.00
10	17325.00	32.23	6.10	14.20	Vertical	40.33	13.00	27.33	315.00

Note: 1. The other Spurious RF Radiated emissions level is no more than noise floor.
2. The worst emission was found in the antenna is Vertical position.



LTE Band 7 QPSK 5MHz CH-Middle, RB 1

Harmonic	Frequency (MHz)	SG (dBm)	Cable Loss (dB)	Gain (dBi)	Antenna Polarization	EIRP Level (dBm)	Limit (dBm)	Margin (dB)	Azimuth (deg)
2	5065.80	28.80	3.40	12.50	Vertical	37.90	25.00	12.90	135.00
3	7598.60	22.81	4.40	12.20	Vertical	30.61	25.00	5.61	180.00
4	10130.63	31.58	4.70	11.30	Vertical	38.18	25.00	13.18	90.00
5	12675.00	36.47	5.40	13.20	Vertical	44.27	25.00	19.27	45.00
6	15210.00	36.25	6.10	13.10	Vertical	43.25	25.00	18.25	315.00
7	17745.00	35.11	6.10	14.20	Vertical	43.21	25.00	18.21	90.00
8	20280.00	--	--	--	--	/	25.00	/	/
9	22815.00	--	--	--	--	/	25.00	/	/
10	25350.00	--	--	--	--	/	25.00	/	/

Note: 1. The other Spurious RF Radiated emissions level is no more than noise floor.

2. The worst emission was found in the antenna is Vertical position.

LTE Band 7 QPSK 20MHz CH-Middle, RB 1

Harmonic	Frequency (MHz)	SG (dBm)	Cable Loss (dB)	Gain (dBi)	Antenna Polarization	EIRP Level (dBm)	Limit (dBm)	Margin (dB)	Azimuth (deg)
2	5052.38	30.15	3.40	12.50	Vertical	39.25	25.00	14.25	0.00
3	7578.00	22.85	4.40	12.20	Vertical	30.65	25.00	5.65	45.00
4	10104.00	34.13	4.70	11.30	Vertical	40.73	25.00	15.73	180.00
5	12675.00	36.66	5.40	13.20	Vertical	44.46	25.00	19.46	45.00
6	15210.00	34.83	6.10	13.10	Vertical	41.83	25.00	16.83	315.00
7	17745.00	34.52	6.10	14.20	Vertical	42.62	25.00	17.62	180.00
8	20280.00	--	--	--	--	/	25.00	/	/
9	22815.00	--	--	--	--	/	25.00	/	/
10	25350.00	--	--	--	--	/	25.00	/	/

Note: 1. The other Spurious RF Radiated emissions level is no more than noise floor.

2. The worst emission was found in the antenna is Vertical position.



LTE Band 13 QPSK 5MHz CH-Middle, RB 1

Harmonic	Frequency (MHz)	SG (dBm)	Cable Loss (dB)	Gain (dBi)	Antenna Polarization	EIRP Level (dBm)	Limit (dBm)	Margin (dB)	Azimuth (deg)
2	1559.80	53.17	3.40	12.50	Vertical	62.27	40.00	22.27	45.00
Harmonic	Frequency (MHz)	SG (dBm)	Cable Loss (dB)	Gain (dBi)	Antenna Polarization	ERP Level (dBm)	Limit (dBm)	Margin (dB)	Azimuth (deg)
3	2339.60	52.18	2.10	11.10	Vertical	59.03	13.00	46.03	90.00
4	3128.00	46.10	2.30	13.10	Vertical	54.75	13.00	41.75	180.00
5	3910.00	47.86	2.60	12.70	Vertical	55.81	13.00	42.81	45.00
6	4692.00	45.84	3.30	12.50	Vertical	52.89	13.00	39.89	45.00
7	5474.00	46.05	3.40	12.50	Vertical	53.00	13.00	40.00	90.00
8	6256.00	46.61	3.30	12.50	Vertical	53.66	13.00	40.66	135.00
9	7038.00	45.79	3.80	11.50	Vertical	51.34	13.00	38.34	45.00
10	7820.00	44.87	4.20	11.80	Vertical	50.32	13.00	37.32	90.00

Note: 1. The other Spurious RF Radiated emissions level is no more than noise floor.

2. The worst emission was found in the antenna is Vertical position.

LTE Band 13 QPSK 10MHz CH-Middle, RB 1

Harmonic	Frequency (MHz)	SG (dBm)	Cable Loss (dB)	Gain (dBi)	Antenna Polarization	EIRP Level (dBm)	Limit (dBm)	Margin (dB)	Azimuth (deg)
2	1555.53	53.56	3.40	12.50	Vertical	62.66	40.00	22.66	45.00
Harmonic	Frequency (MHz)	SG (dBm)	Cable Loss (dB)	Gain (dBi)	Antenna Polarization	ERP Level (dBm)	Limit (dBm)	Margin (dB)	Azimuth (deg)
3	2332.66	52.12	2.10	11.10	Vertical	58.97	13.00	45.97	90.00
4	3128.00	48.16	2.30	13.10	Vertical	56.81	13.00	43.81	315.00
5	3910.00	47.91	2.60	12.70	Vertical	55.86	13.00	42.86	0.00
6	4692.00	46.20	3.30	12.50	Vertical	53.25	13.00	40.25	315.00
7	5474.00	46.72	3.40	12.50	Vertical	53.67	13.00	40.67	315.00
8	6256.00	47.80	3.30	12.50	Vertical	54.85	13.00	41.85	180.00
9	7038.00	46.93	3.80	11.50	Vertical	52.48	13.00	39.48	270.00
10	7820.00	45.85	4.20	11.80	Vertical	51.30	13.00	38.30	90.00

Note: 1. The other Spurious RF Radiated emissions level is no more than noise floor.

2. The worst emission was found in the antenna is Vertical position.



LTE Band 38 QPSK 5MHz CH-Middle, RB 1

Harmonic	Frequency (MHz)	SG (dBm)	Cable Loss (dB)	Gain (dBi)	Antenna Polarization	EIRP Level (dBm)	Limit (dBm)	Margin (dB)	Azimuth (deg)
2	5185.00	35.61	3.20	12.50	Vertical	44.91	25.00	19.91	270.00
3	7777.50	26.16	4.40	12.30	Vertical	34.06	25.00	9.06	180.00
4	10370.00	33.91	4.70	11.80	Vertical	41.01	25.00	16.01	0.00
5	12962.50	31.73	5.40	14.00	Vertical	40.33	25.00	15.33	45.00
6	15555.00	33.55	6.10	16.80	Vertical	44.25	25.00	19.25	315.00
7	18147.50	--	--	--	--	/	25.00	/	/
8	20740.00	--	--	--	--	/	25.00	/	/
9	23332.50	--	--	--	--	/	25.00	/	/
10	25925.00	--	--	--	--	/	25.00	/	/

Note: 1. The other Spurious RF Radiated emissions level is no more than noise floor.

2. The worst emission was found in the antenna is Vertical position.

LTE Band 38 QPSK 20MHz CH-Middle, RB 1

Harmonic	Frequency (MHz)	SG (dBm)	Cable Loss (dB)	Gain (dBi)	Antenna Polarization	EIRP Level (dBm)	Limit (dBm)	Margin (dB)	Azimuth (deg)
2	5170.00	30.87	3.20	12.50	Vertical	40.17	25.00	15.17	0.00
3	7755.00	24.22	4.40	12.30	Vertical	32.12	25.00	7.12	45.00
4	10340.00	35.34	4.70	11.80	Vertical	42.44	25.00	17.44	315.00
5	12925.00	35.35	5.40	14.00	Vertical	43.95	25.00	18.95	90.00
6	15510.00	32.24	6.10	16.80	Vertical	42.94	25.00	17.94	225.00
7	18095.00	--	--	--	--	/	25.00	/	/
8	20680.00	--	--	--	--	/	25.00	/	/
9	23265.00	--	--	--	--	/	25.00	/	/
10	25850.00	--	--	--	--	/	25.00	/	/

Note: 1. The other Spurious RF Radiated emissions level is no more than noise floor.

2. The worst emission was found in the antenna is Vertical position.



LTE Band 66 QPSK 1.4MHz CH-Middle, RB 1

Harmonic	Frequency (MHz)	SG (dBm)	Cable Loss (dB)	Gain (dBi)	Antenna Polarization	EIRP Level (dBm)	Limit (dBm)	Margin (dB)	Azimuth (deg)
2	3464.30	46.63	2.70	12.70	Vertical	56.63	13.00	43.63	0.00
3	5197.50	43.64	3.20	12.50	Vertical	52.94	13.00	39.94	45.00
4	6930.00	45.20	4.20	11.80	Vertical	52.80	13.00	39.80	270.00
5	8662.50	40.69	4.40	12.50	Vertical	48.79	13.00	35.79	135.00
6	10395.00	37.59	4.70	11.80	Vertical	44.69	13.00	31.69	180.00
7	12127.50	36.44	5.20	13.80	Vertical	45.04	13.00	32.04	45.00
8	13860.00	38.27	5.70	13.20	Vertical	45.77	13.00	32.77	315.00
9	15592.50	32.33	6.10	16.80	Vertical	43.03	13.00	30.03	90.00
10	17325.00	34.26	6.10	14.20	Vertical	42.36	13.00	29.36	225.00

Note: 1. The other Spurious RF Radiated emissions level is no more than noise floor.
2. The worst emission was found in the antenna is Vertical position.

LTE Band 66 QPSK 5MHz CH-Middle, RB 1

Harmonic	Frequency (MHz)	SG (dBm)	Cable Loss (dB)	Gain (dBi)	Antenna Polarization	EIRP Level (dBm)	Limit (dBm)	Margin (dB)	Azimuth (deg)
2	3460.50	46.29	2.70	12.70	Vertical	56.29	13.00	43.29	45.00
3	5191.50	43.34	3.20	12.50	Vertical	52.64	13.00	39.64	315.00
4	6930.00	46.35	4.20	11.80	Vertical	53.95	13.00	40.95	45.00
5	8662.50	39.91	4.40	12.50	Vertical	48.01	13.00	35.01	90.00
6	10395.00	36.27	4.70	11.80	Vertical	43.37	13.00	30.37	225.00
7	12127.50	33.62	5.20	13.80	Vertical	42.22	13.00	29.22	45.00
8	13860.00	36.25	5.70	13.20	Vertical	43.75	13.00	30.75	180.00
9	15592.50	30.66	6.10	16.80	Vertical	41.36	13.00	28.36	315.00
10	17325.00	32.94	6.10	14.20	Vertical	41.04	13.00	28.04	45.00

Note: 1. The other Spurious RF Radiated emissions level is no more than noise floor.
2. The worst emission was found in the antenna is Vertical position.



LTE Band 66 QPSK 20MHz CH-Middle, RB 1

Harmonic	Frequency (MHz)	SG (dBm)	Cable Loss (dB)	Gain (dBi)	Antenna Polarization	EIRP Level (dBm)	Limit (dBm)	Margin (dB)	Azimuth (deg)
2	3447.00	46.97	2.70	12.70	Vertical	56.97	13.00	43.97	270.00
3	5170.50	43.64	3.20	12.50	Vertical	52.94	13.00	39.94	135.00
4	6930.00	47.12	4.20	11.80	Vertical	54.72	13.00	41.72	180.00
5	8662.50	40.23	4.40	12.50	Vertical	48.33	13.00	35.33	45.00
6	10395.00	37.29	4.70	11.80	Vertical	44.39	13.00	31.39	0.00
7	12127.50	33.77	5.20	13.80	Vertical	42.37	13.00	29.37	90.00
8	13860.00	36.96	5.70	13.20	Vertical	44.46	13.00	31.46	45.00
9	15592.50	33.15	6.10	16.80	Vertical	43.85	13.00	30.85	315.00
10	17325.00	35.15	6.10	14.20	Vertical	43.25	13.00	30.25	90.00

Note: 1. The other Spurious RF Radiated emissions level is no more than noise floor.
2. The worst emission was found in the antenna is Vertical position.



6 Main Test Instruments

Name	Manufacturer	Type	Serial Number	Calibration Date	Expiration Date
Signal Analyzer	R&S	FSV30	104028	2021-05-15	2022-05-14
Loop antenna	SCHWARZBECK	FMZB1519	1519-047	2020-04-02	2023-04-01
TRILOG Broadband Antenna	Schwarzbeck	VULB 9163	01111	2019-09-12	2022-09-11
Horn Antenna	Schwarzbeck	BBHA 9120D	1594	2020-12-17	2023-12-16
Horn Antenna	ETS-Lindgren	3160-09	00102643	2020-10-10	2023-10-09
Software	R&S	EMC32	10.35.10	/	/
Communication tester	Anritsu	MT8821C	6201538758	2021-05-15	2022-05-14
Climate Chamber	WEISS	VT 4002	582261194500 10	2021-05-15	2022-05-14
Climate Chamber	R&S	CMW500	150415	2021-05-15	2022-05-14
Spectrum Analyzer	Keysight	N9020A	MY52330084	2021-05-15	2022-05-14
Wireless Communication Tester	Agilent	E5515C	GB44400275	2021-05-15	2022-05-14
Spectrum Analyzer	R&S	FSV3030	101411	2021-12-12	2022-12-11

*****END OF REPORT *****



ANNEX A: The EUT Appearance

The EUT Appearance are submitted separately.



ANNEX B: Test Setup Photos

The Test Setup Photos are submitted separately.



ANNEX C: Product Change Description

The Product Change Description are submitted separately.