

### 5.3. Band Edge Compliance

#### Ambient condition

Temperature	Relative humidity	Pressure
23°C ~25°C	45%~50%	101.5kPa

#### Method of Measurement

The EUT was connected to Spectrum Analyzer and Base Station Simulator via power Splitter. The band edge of the lowest and highest channels were measured. The average detector is used. RBW is set to  $\geq 1\%EBW$ , VBW is set to 3x RBW.

Spectrum analyzer plots are included on the following pages.

#### Test Setup

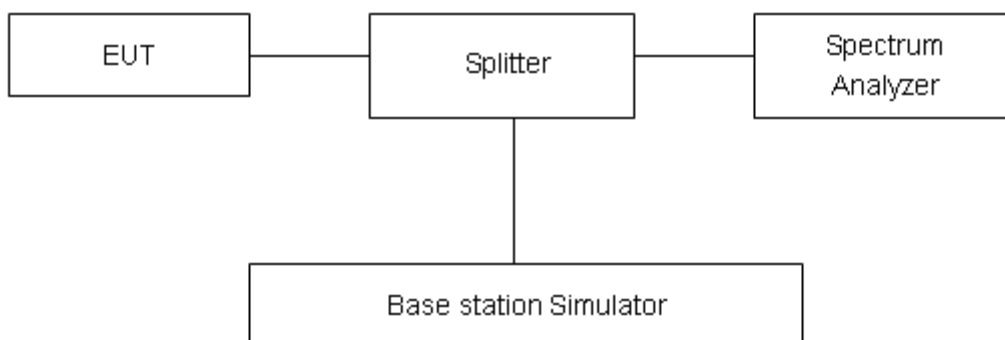

#### Limits

Rule Part 22.917(a) specifies that “The power of any emission outside of the authorized operating frequency ranges must be attenuated below the transmitting power (P) by a factor of at least 43 + 10 log(P) dB.”

Limit	-13 dBm
-------	---------

#### Measurement Uncertainty

The assessed measurement uncertainty to ensure 95% confidence level for the normal distribution is with the coverage factor  $k = 1.96$ ,  $U=0.684dB$ .

Test Result:

GSM 850 CH-Low

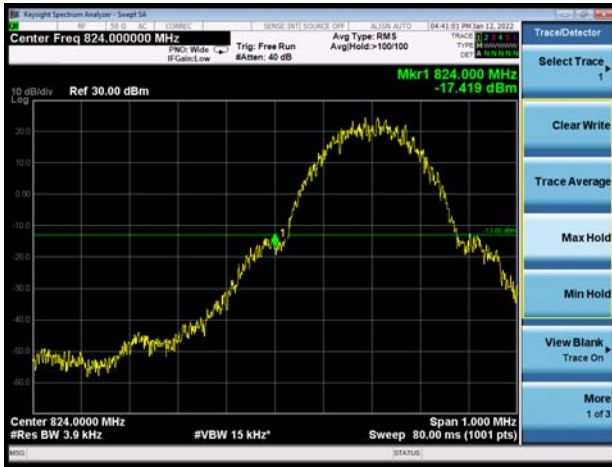

GSM 850 CH-High



GSM 850 GPRS CH-Low

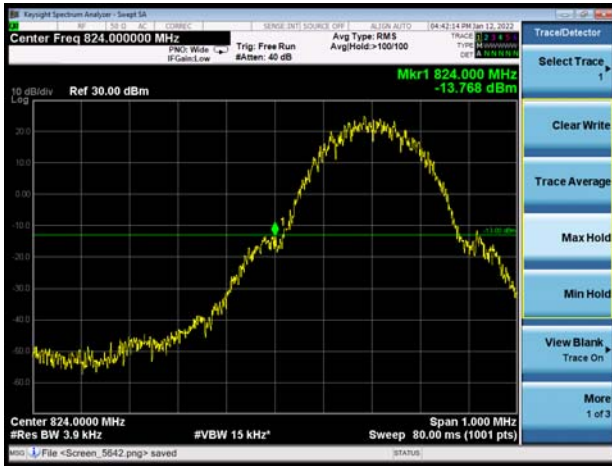

GSM 850 GPRS CH-High

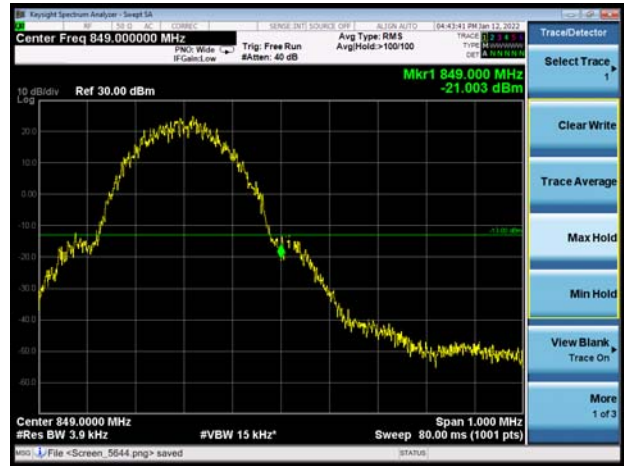

GSM 850 EGPRS CH-Low

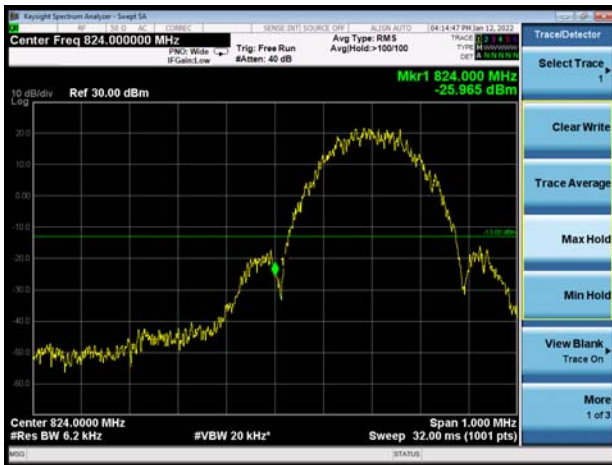

GSM 850 EGPRS CH-High

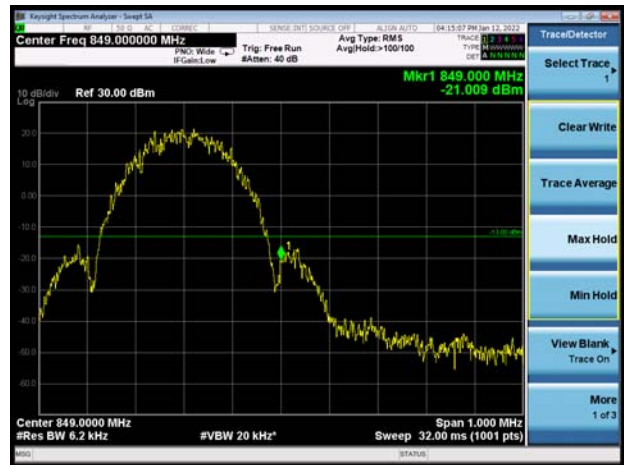



### WCDMA Band V CH-Low



### WCDMA Band V CH-High



### LTE Band 5 QPSK 1.4MHz CH-Low 1RB

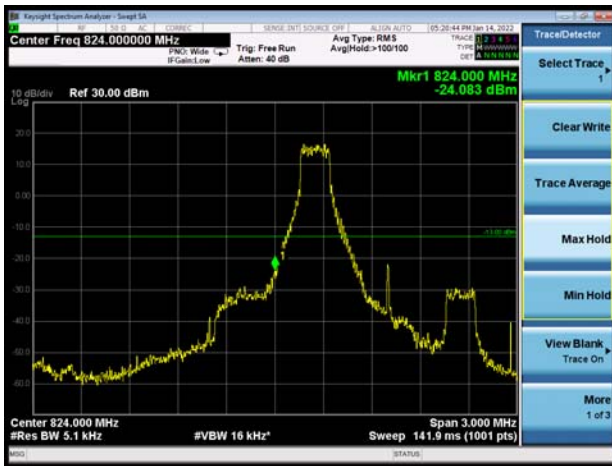

### LTE Band 5 QPSK 1.4MHz CH-High 1RB

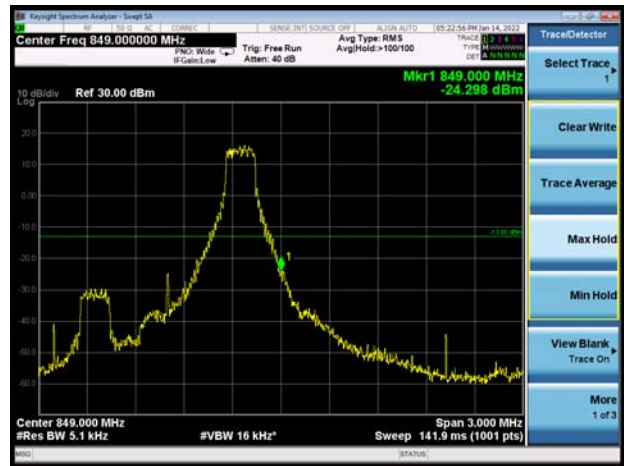

### LTE Band 5 QPSK 1.4MHz CH-Low 100%RB

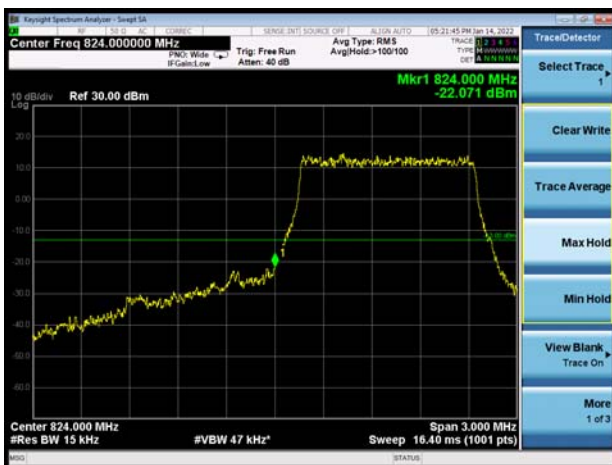

### LTE Band 5 QPSK 1.4MHz CH-High 100%RB

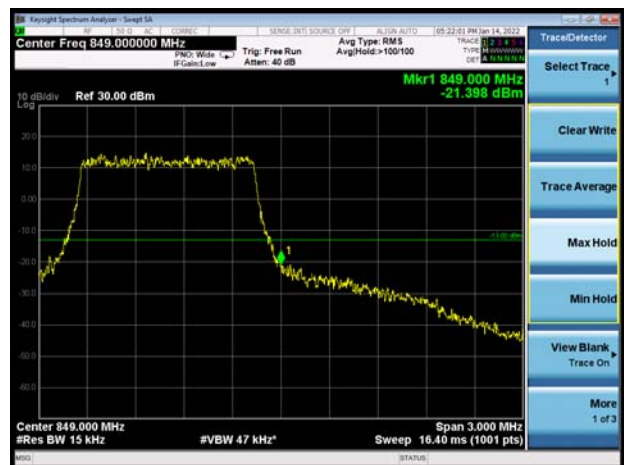



### LTE Band 5 QPSK 3MHz CH-Low 1RB

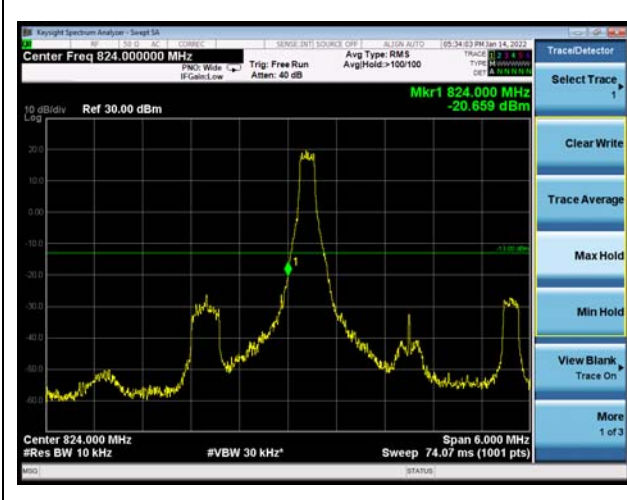

### LTE Band 5 QPSK 3MHz CH-High 1RB

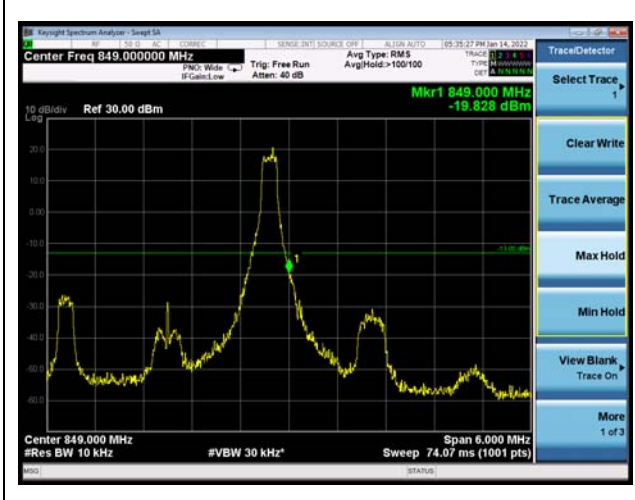

LTE Band 5 QPSK 3MHz CH-Low 100%RB



LTE Band 5 QPSK 3MHz CH-High 100%RB

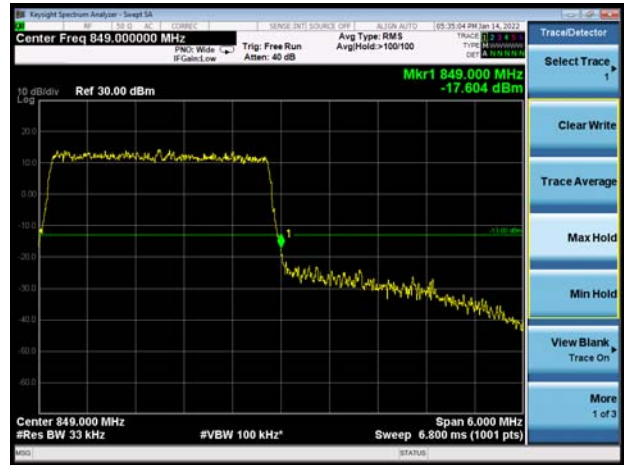

LTE Band 5 QPSK 5MHz CH-Low 1RB



LTE Band 5 QPSK 5MHz CH-High 1RB

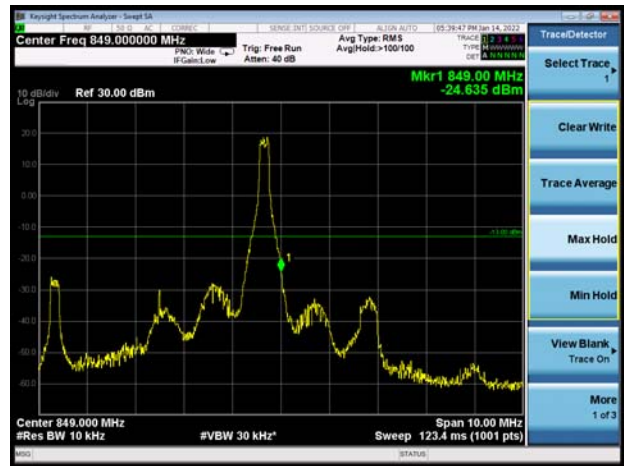

LTE Band 5 QPSK 5MHz CH-Low 100%RB

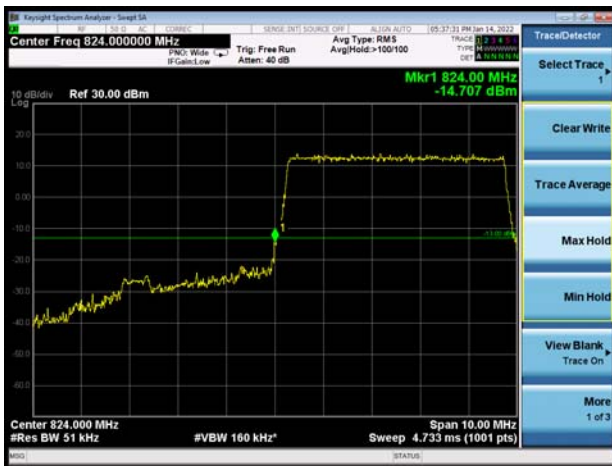

LTE Band 5 QPSK 5MHz CH-High 100%RB







LTE Band 5 QPSK 10MHz CH-Low 1RB

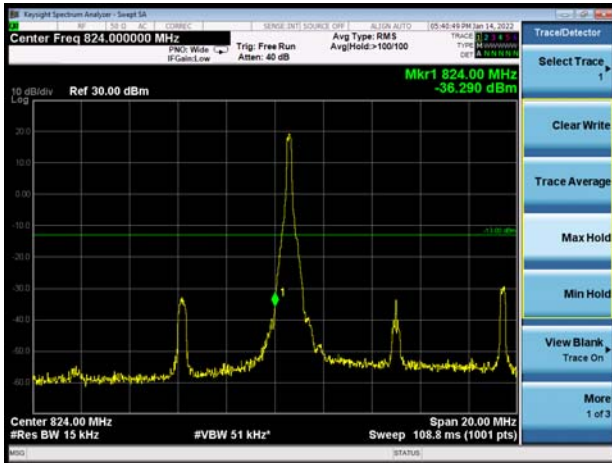

LTE Band 5 QPSK 10MHz CH-High 1RB

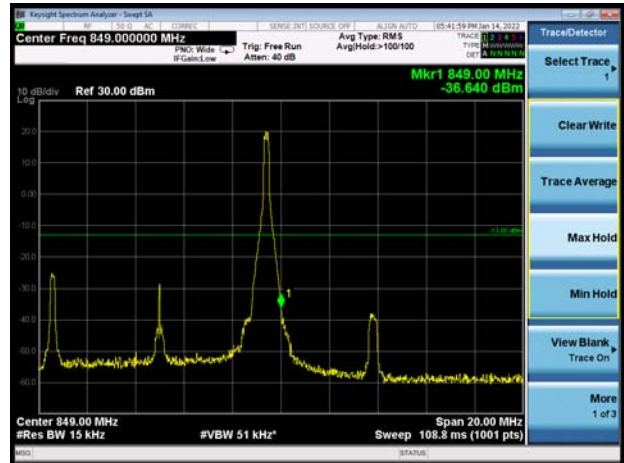

LTE Band 5 QPSK 10MHz CH-Low 100%RB

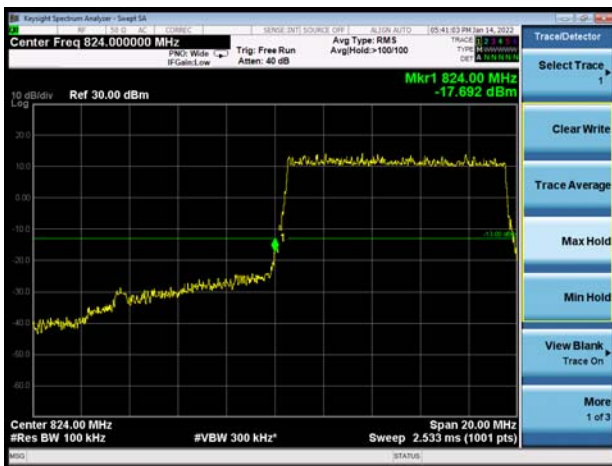

LTE Band 5 QPSK 10MHz CH-High 100%RB



LTE Band 5 16QAM 1.4MHz CH-Low 1RB



LTE Band 5 16QAM 1.4MHz CH-High 1RB

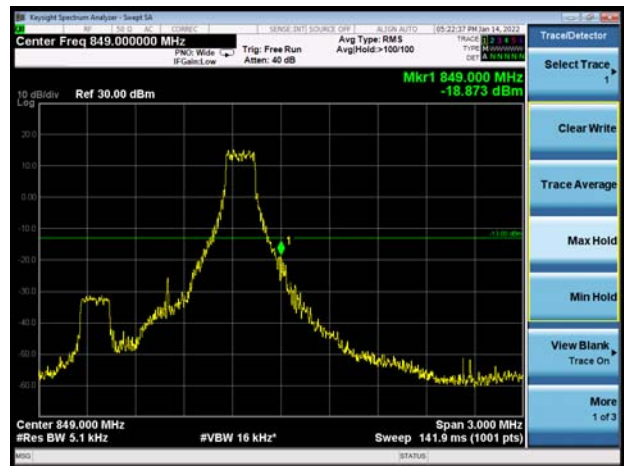

LTE Band 5 16QAM 1.4MHz CH-Low 100%RB

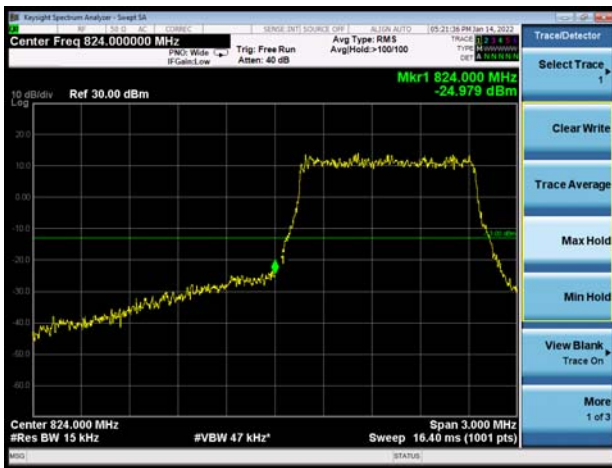

LTE Band 5 16QAM 1.4MHz CH-High 100%RB



LTE Band 5 16QAM 3MHz CH-Low 1RB

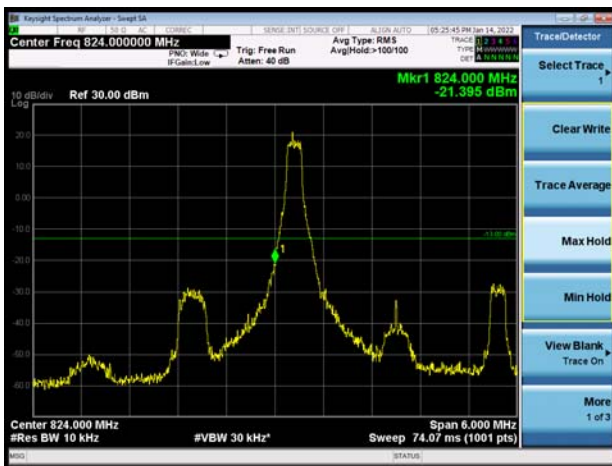

LTE Band 5 16QAM 3MHz CH-High 1RB

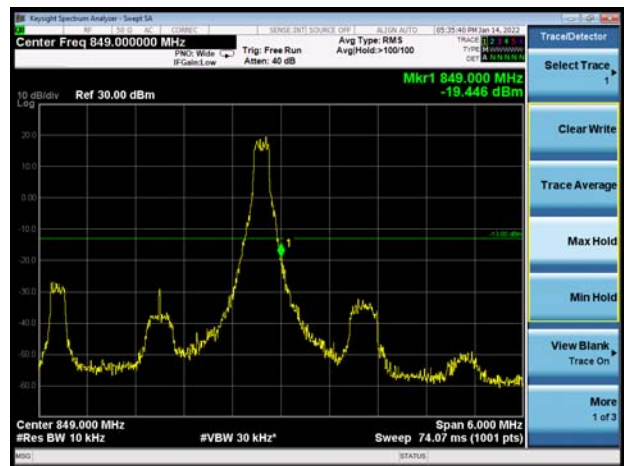

LTE Band 5 16QAM 3MHz CH-Low 100%RB

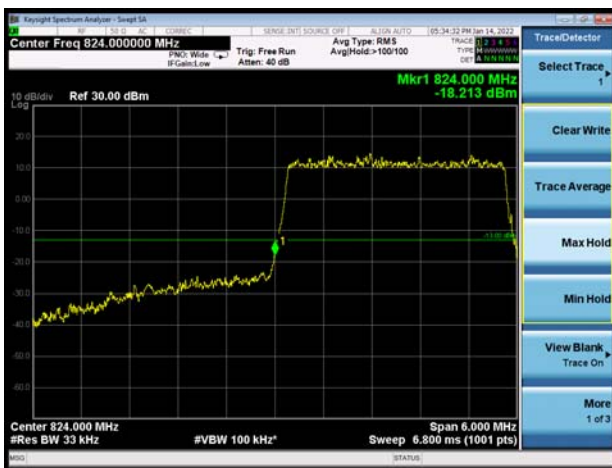

LTE Band 5 16QAM 3MHz CH-High 100%RB

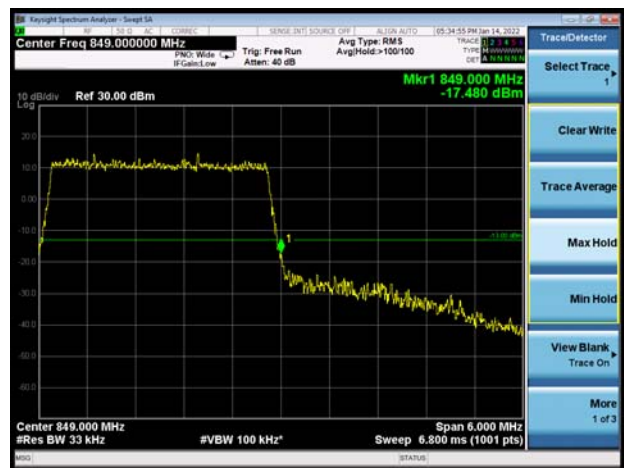

LTE Band 5 16QAM 5MHz CH-Low 1RB

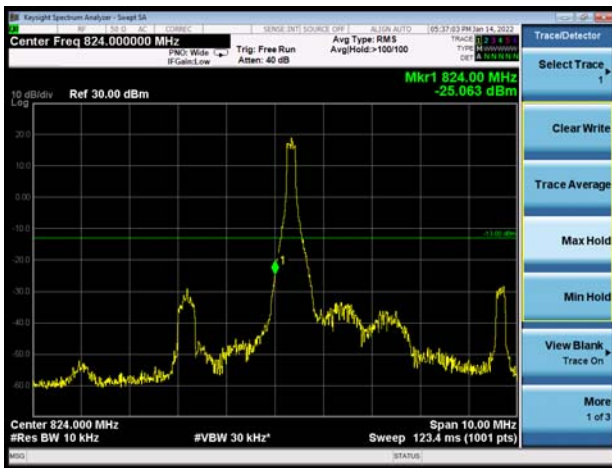

LTE Band 5 16QAM 5MHz CH-High 1RB

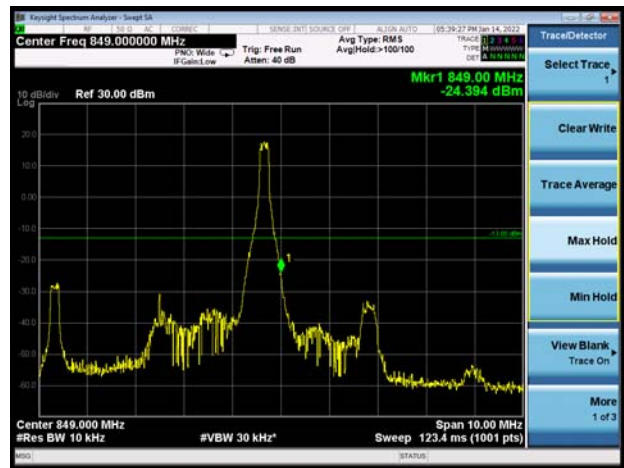

LTE Band 5 16QAM 5MHz CH-Low 100%RB



LTE Band 5 16QAM 5MHz CH-High 100%RB

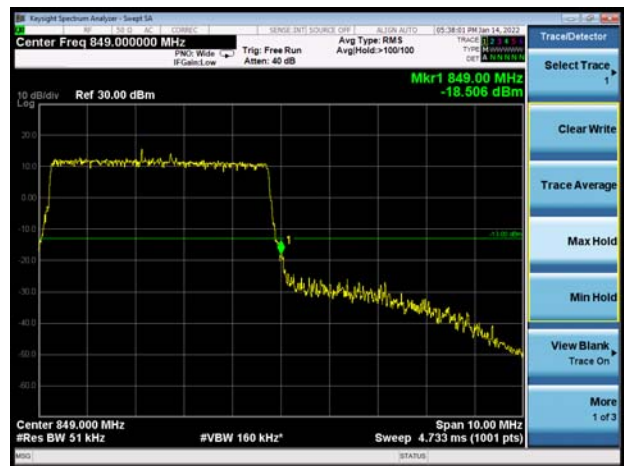

LTE Band 5 16QAM 10MHz CH-Low 1RB

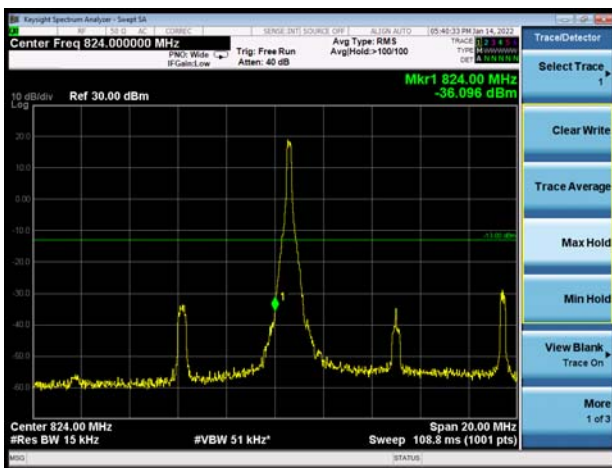

LTE Band 5 16QAM 10MHz CH-High 1RB

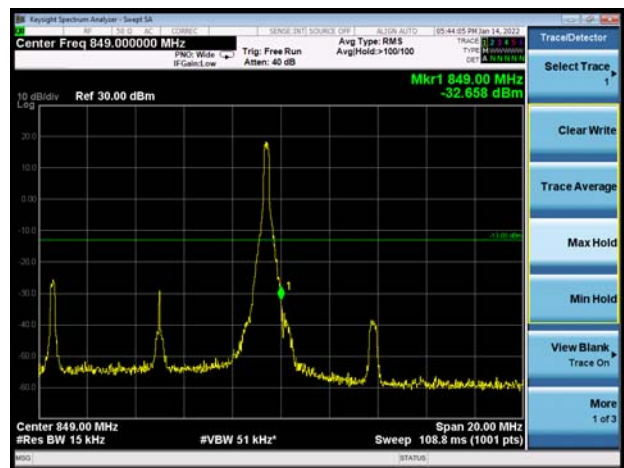



LTE Band 5 16QAM 10MHz CH-Low 100%RB

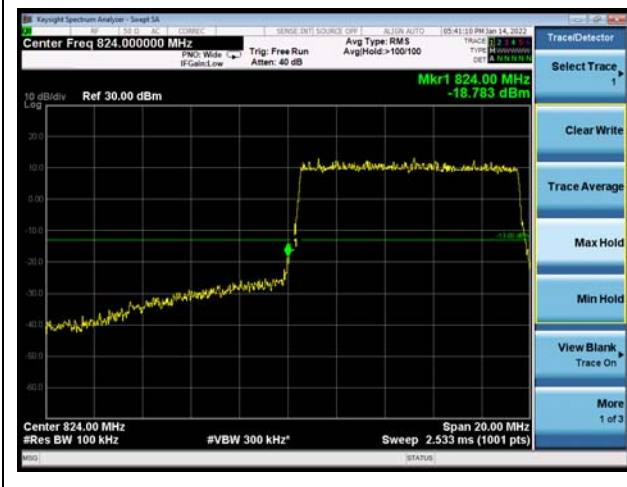

LTE Band 5 16QAM 10MHz CH-High 100%RB



LTE Band 26 QPSK 1.4MHz CH-Low 1RB



LTE Band 26 QPSK 1.4MHz CH-High 1RB

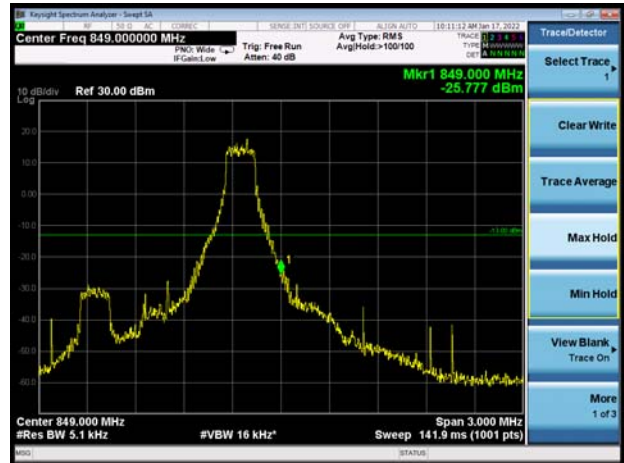

LTE Band 26 QPSK 1.4MHz CH-Low 100%RB

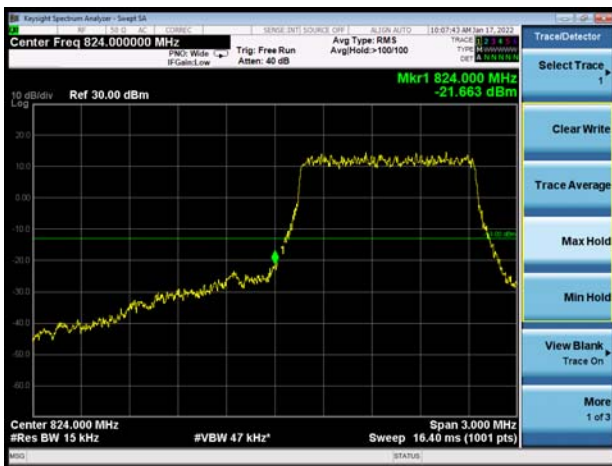

LTE Band 26 QPSK 1.4MHz CH-High 100%RB

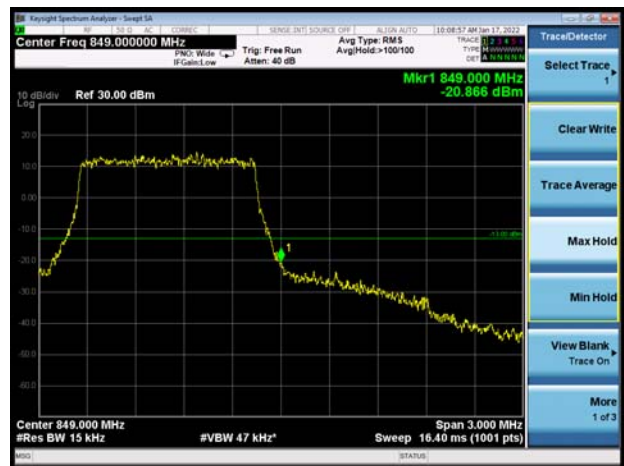

LTE Band 26 QPSK 3MHz CH-Low 1RB

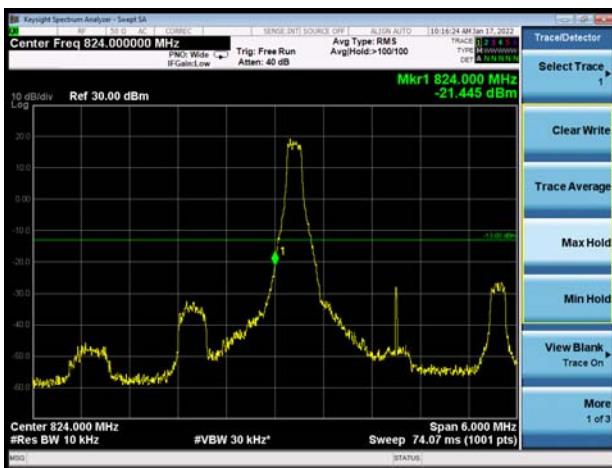

LTE Band 26 QPSK 3MHz CH-High 1RB

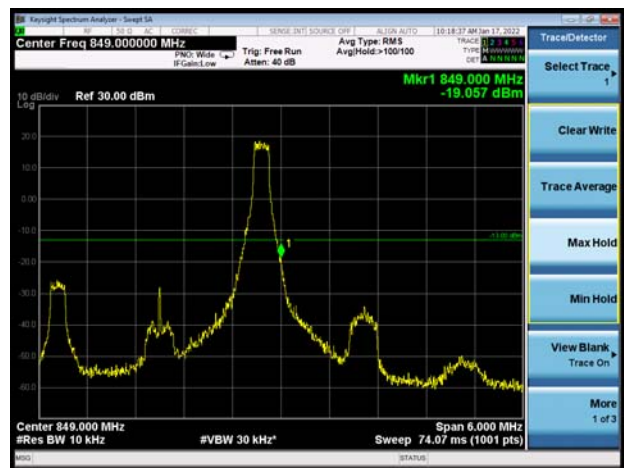

LTE Band 26 QPSK 3MHz CH-Low 100%RB



LTE Band 26 QPSK 3MHz CH-High 100%RB

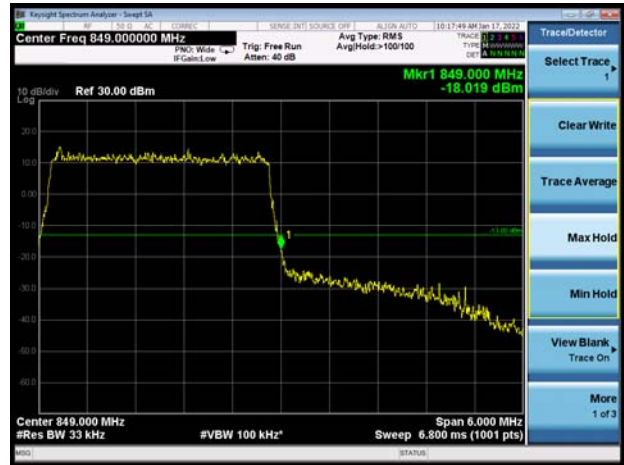

LTE Band 26 QPSK 5MHz CH-Low 1RB



LTE Band 26 QPSK 5MHz CH-High 1RB



LTE Band 26 QPSK 5MHz CH-Low 100%RB



LTE Band 26 QPSK 5MHz CH-High 100%RB



LTE Band 26 QPSK 10MHz CH-Low 1RB

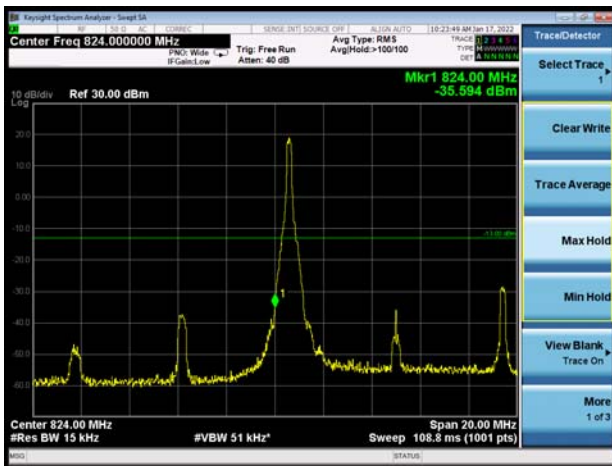

LTE Band 26 QPSK 10MHz CH-High 1RB

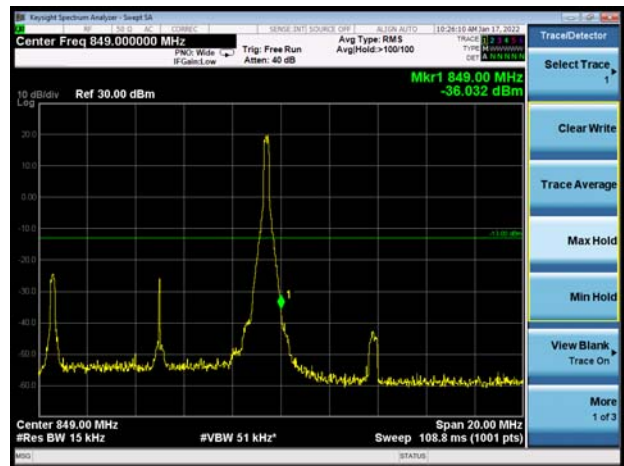

LTE Band 26 QPSK 10MHz CH-Low 100%RB

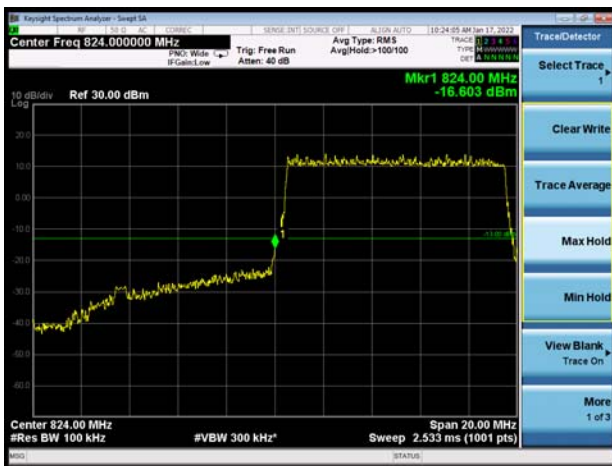

LTE Band 26 QPSK 10MHz CH-High 100%RB

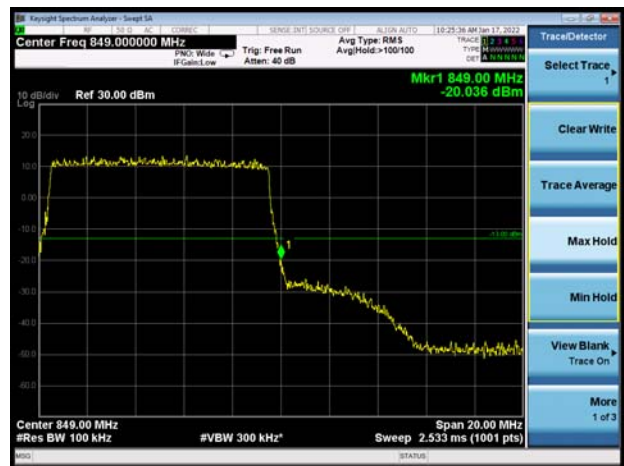

LTE Band 26 QPSK 15MHz CH-Low 1RB

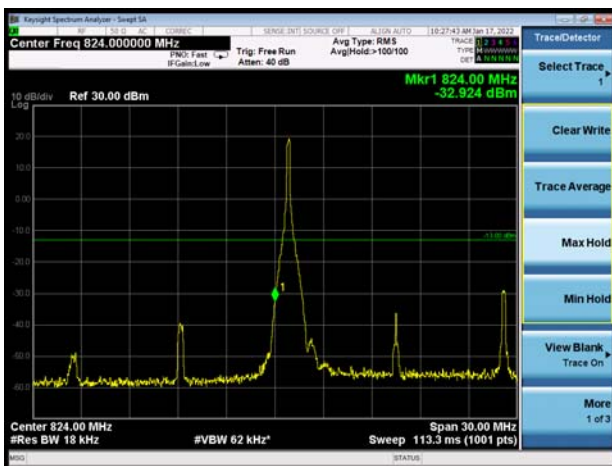

LTE Band 26 QPSK 15MHz CH-High 1RB

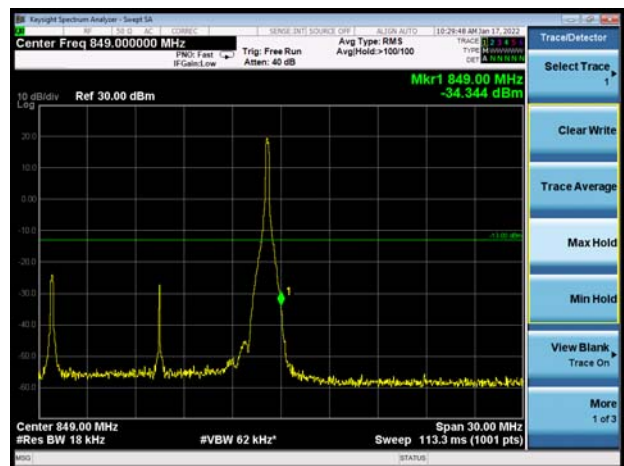

LTE Band 26 QPSK 15MHz CH-Low 100%RB



LTE Band 26 QPSK 15MHz CH-High 100%RB

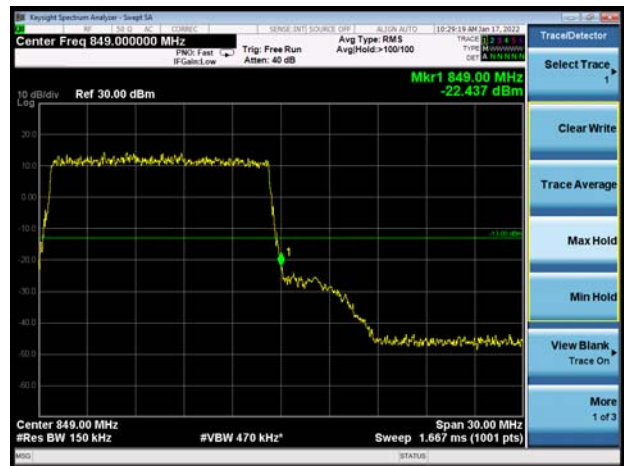

LTE Band 26 16QAM 1.4MHz CH-Low 1RB

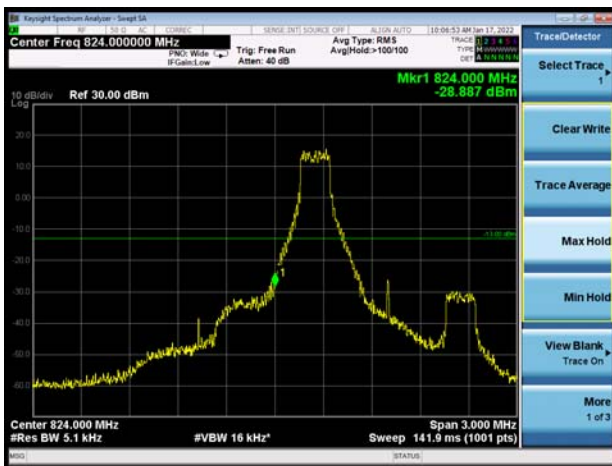

LTE Band 26 16QAM 1.4MHz CH-High 1RB

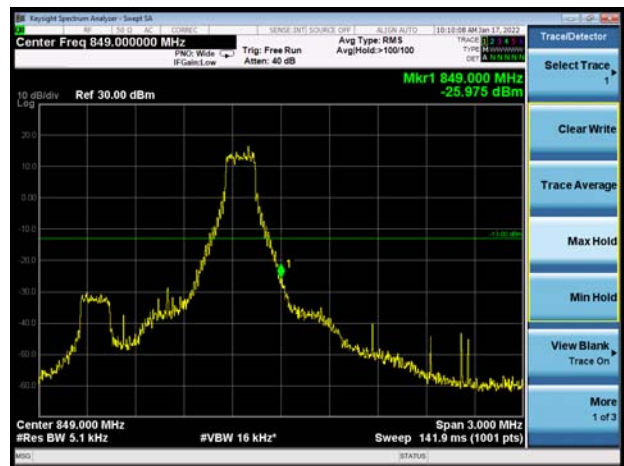

LTE Band 26 16QAM 1.4MHz CH-Low 100%RB

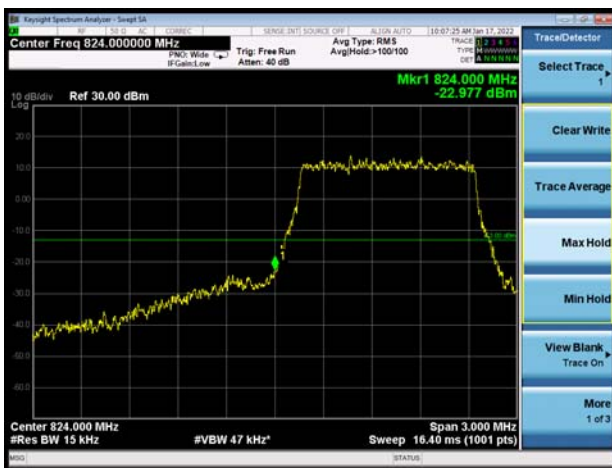

LTE Band 26 16QAM 1.4MHz CH-High 100%RB

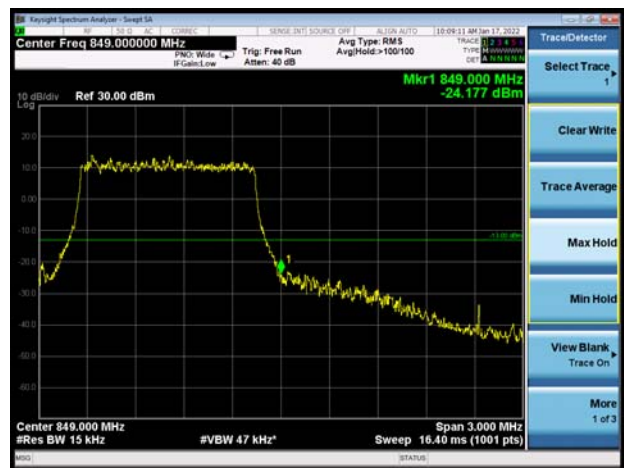



LTE Band 26 16QAM 3MHz CH-Low 1RB

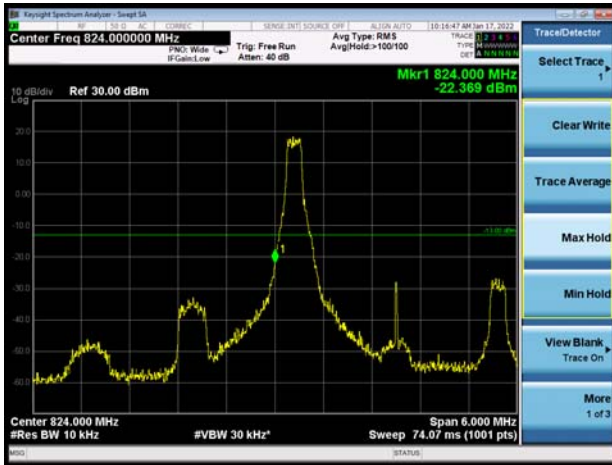

LTE Band 26 16QAM 3MHz CH-High 1RB

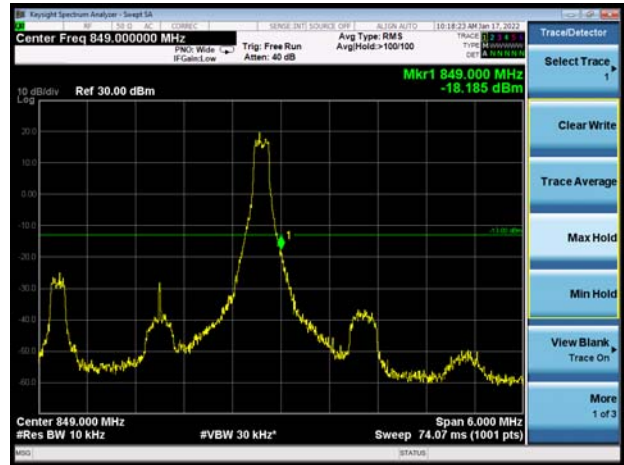

LTE Band 26 16QAM 3MHz CH-Low 100%RB

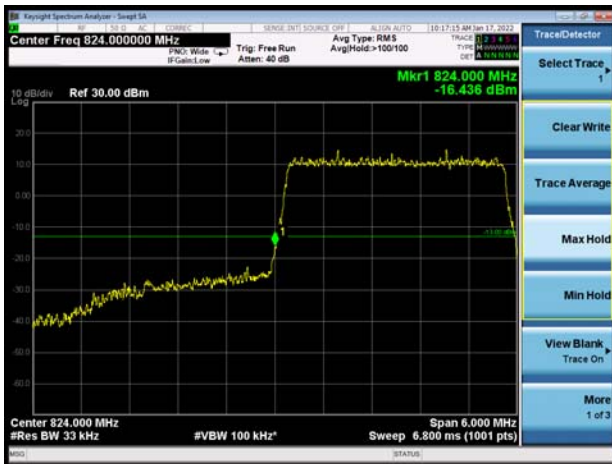

LTE Band 26 16QAM 3MHz CH-High 100%RB

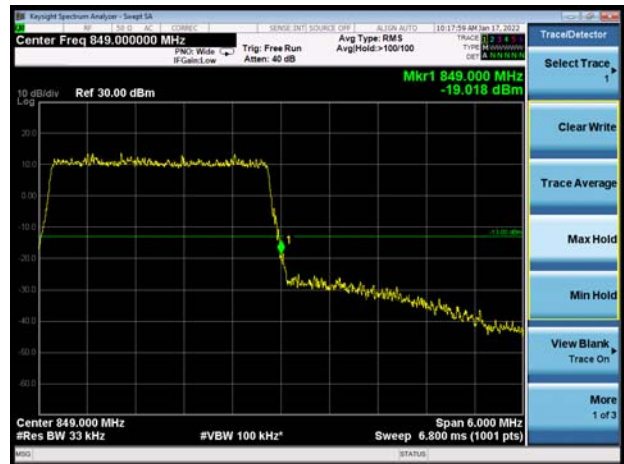

LTE Band 26 16QAM 5MHz CH-Low 1RB

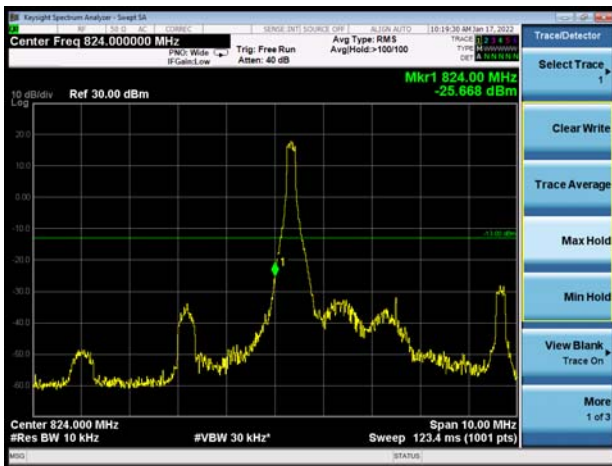

LTE Band 26 16QAM 5MHz CH-High 1RB

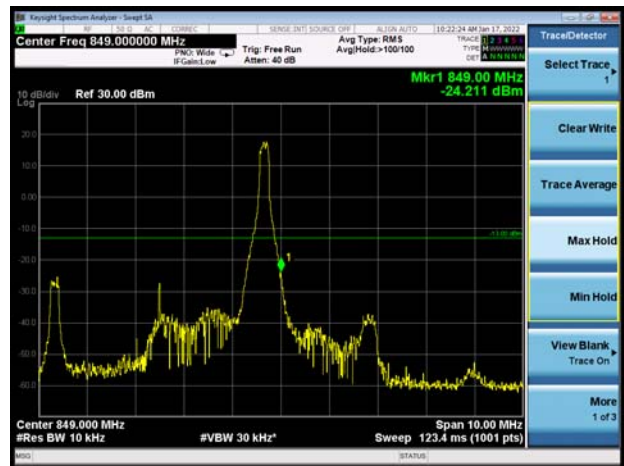

LTE Band 26 16QAM 5MHz CH-Low 100%RB



LTE Band 26 16QAM 5MHz CH-High 100%RB



LTE Band 26 16QAM 10MHz CH-Low 1RB

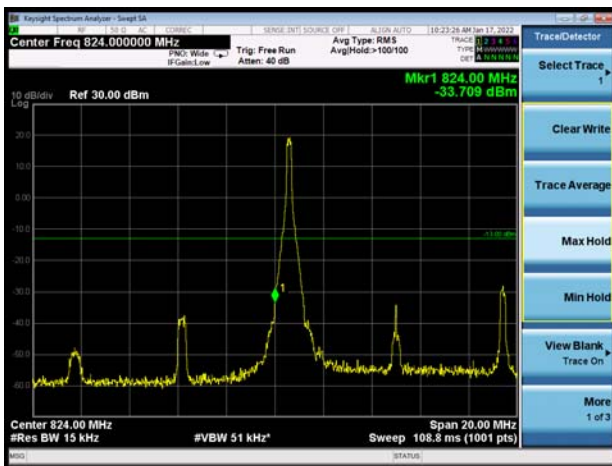

LTE Band 26 16QAM 10MHz CH-High 1RB

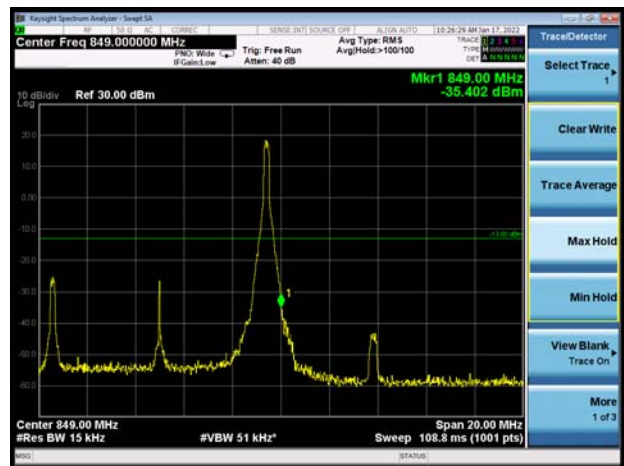

LTE Band 26 16QAM 10MHz CH-Low 100%RB

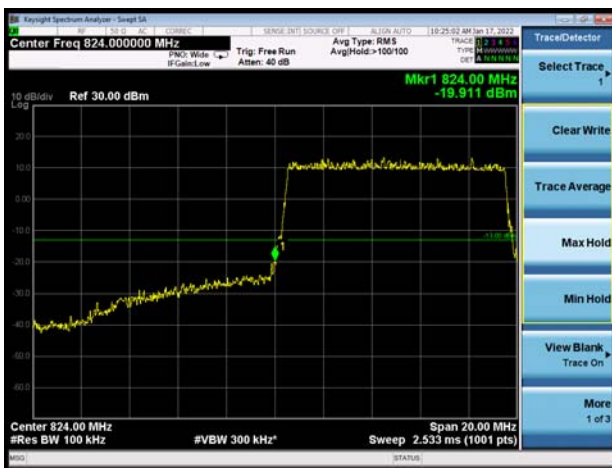

LTE Band 26 16QAM 10MHz CH-High 100%RB

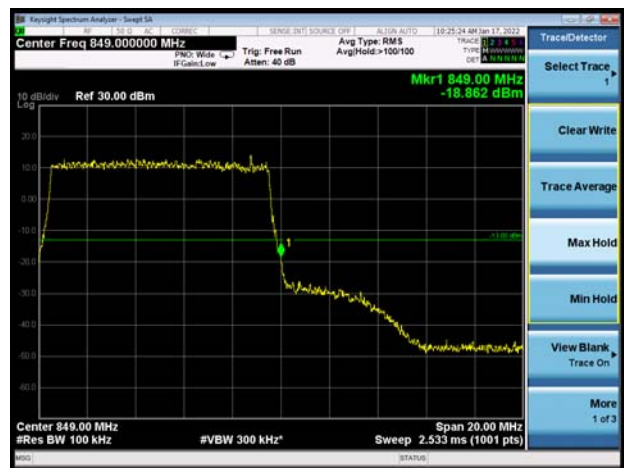



LTE Band 26 16QAM 15MHz CH-Low 1RB

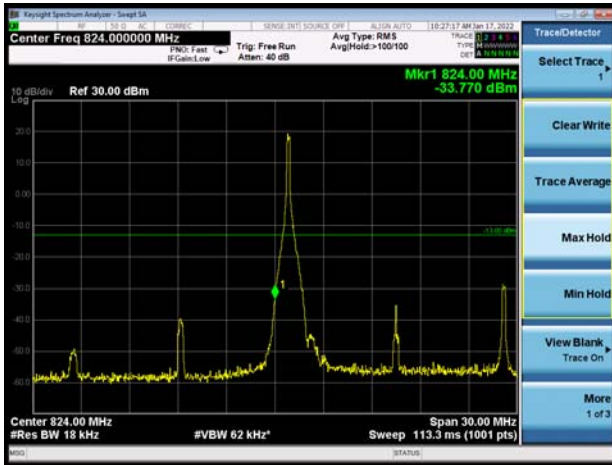

LTE Band 26 16QAM 15MHz CH-High 1RB

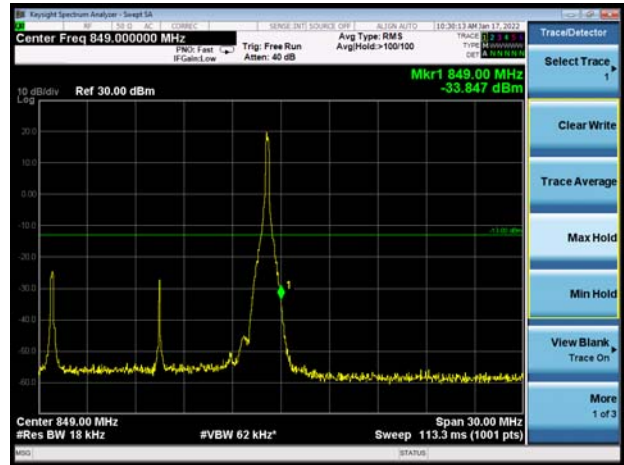

LTE Band 26 16QAM 15MHz CH-Low 100%RB



LTE Band 26 16QAM 15MHz CH-High 100%RB



### 5.4. Peak-to-Average Power Ratio (PAPR)

#### Ambient condition

Temperature	Relative humidity	Pressure
23°C ~25°C	45%~50%	101.5kPa

#### Methods of Measurement

Measure the total peak power and record as  $P_{Pk}$ . And measure the total average power and record as  $P_{Avg}$ . Both the peak and average power levels must be expressed in the same logarithmic units (e.g., dBm). Determine the PAPR from:

$$PAPR (dB) = P_{Pk} (dBm) - P_{Avg} (dBm).$$

#### Test Setup

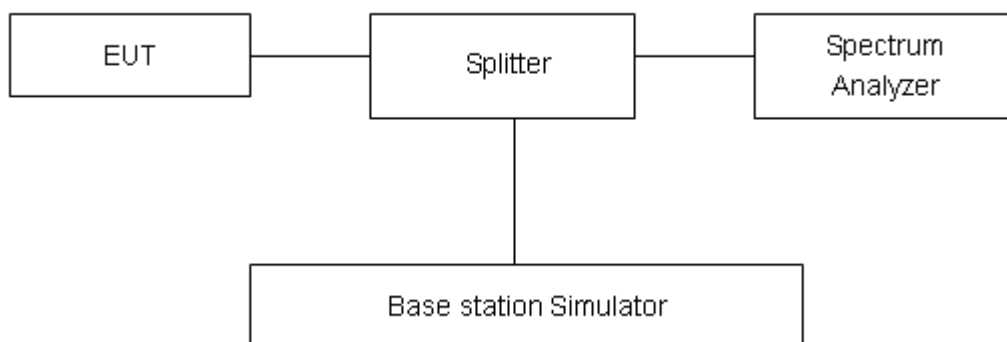

#### Limits

According to the Sec. 22.913(d), The peak-to-average ratio (PAR) of the transmission must not exceed 13 dB.

#### Measurement Uncertainty

The assessed measurement uncertainty to ensure 95% confidence level for the normal distribution is with the coverage factor  $k = 2$ ,  $U = 0.4$  dB.



## Test Results

Mode	Channel	Frequency (MHz)	Peak (dBm)	Avg (dBm)	PAPR (dB)	Limit (dB)	Conclusion
GSM 850 (GMSK)	128	824.2	33.24	30.57	2.67	≤13	PASS
	190	836.6	33.20	30.54	2.66	≤13	PASS
	251	848.8	33.18	30.52	2.66	≤13	PASS
GPRS 850 (GMSK)	128	824.2	33.70	31.03	2.67	≤13	PASS
	190	836.6	33.67	31.00	2.67	≤13	PASS
	251	848.8	33.77	31.11	2.66	≤13	PASS
EGPRS 850 (8PSK)	128	824.2	30.87	25.07	5.80	≤13	PASS
	190	836.6	30.83	25.04	5.79	≤13	PASS
	251	848.8	30.86	25.08	5.78	≤13	PASS
WCDMA Band V (RMC)	4132	826.4	28.10	24.92	3.18	≤13	PASS
	4183	836.6	27.82	24.67	3.15	≤13	PASS
	4233	846.6	27.71	24.68	3.03	≤13	PASS

LTE Band 5								
Modulation	Bandwidth (MHz)	Channel	Frequency (MHz)	Peak (dBm)	Avg (dBm)	PAPR (dB)	Limit (dB)	Conclusion
QPSK	1.4	20407	824.7	29.25	23.71	5.54	≤13	PASS
		20525	836.5	29.13	23.69	5.44	≤13	PASS
		20643	848.3	28.36	23.68	4.68	≤13	PASS
	3	20415	825.5	29.27	23.74	5.53	≤13	PASS
		20525	836.5	29.19	23.77	5.42	≤13	PASS
		20635	847.5	28.49	23.72	4.77	≤13	PASS
	5	20425	826.5	29.27	23.70	5.57	≤13	PASS
		20525	836.5	29.20	23.77	5.43	≤13	PASS
		20625	846.5	28.64	23.76	4.88	≤13	PASS
	10	20450	829	28.95	23.48	5.47	≤13	PASS
		20525	836.5	28.84	23.43	5.41	≤13	PASS
		20600	844	28.67	23.45	5.22	≤13	PASS
16QAM	1.4	20407	824.7	29.18	22.72	6.46	≤13	PASS
		20525	836.5	28.95	22.70	6.25	≤13	PASS
		20643	848.3	28.22	22.61	5.61	≤13	PASS
	3	20415	825.5	29.17	22.78	6.39	≤13	PASS
		20525	836.5	28.98	22.73	6.25	≤13	PASS



	5	20635	847.5	28.38	22.81	5.57	≤13	PASS
		20425	826.5	29.00	22.68	6.32	≤13	PASS
		20525	836.5	28.96	22.81	6.15	≤13	PASS
		20625	846.5	28.43	22.69	5.74	≤13	PASS
	10	20450	829	28.70	22.44	6.26	≤13	PASS
		20525	836.5	28.62	22.40	6.22	≤13	PASS
		20600	844	28.50	22.42	6.08	≤13	PASS

LTE Band 26								
Modulation	Bandwidth (MHz)	Channel	Frequency (MHz)	Peak (dBm)	Avg (dBm)	PAPR (dB)	Limit (dB)	Conclusion
QPSK	1.4	26797	824.7	28.79	23.40	5.39	≤13	PASS
		26915	836.5	28.83	23.47	5.36	≤13	PASS
		27033	848.3	28.04	23.17	4.87	≤13	PASS
	3	26805	825.5	28.92	23.49	5.43	≤13	PASS
		26915	836.5	28.79	23.54	5.25	≤13	PASS
		27025	847.5	28.11	23.16	4.95	≤13	PASS
	5	26815	826.5	28.91	23.51	5.40	≤13	PASS
		26915	836.5	28.88	23.58	5.30	≤13	PASS
		27015	846.5	28.26	23.33	4.93	≤13	PASS
	10	26840	829	28.81	23.51	5.30	≤13	PASS
		26915	836.5	28.73	23.51	5.22	≤13	PASS
		26990	844	28.46	23.29	5.17	≤13	PASS
15	26865	831.5	29.12	23.40	5.72	≤13	PASS	
	26915	836.5	29.11	23.47	5.64	≤13	PASS	
	26965	841.5	28.92	23.39	5.53	≤13	PASS	
16QAM	1.4	26797	824.7	28.59	22.37	6.22	≤13	PASS
		26915	836.5	28.64	22.53	6.11	≤13	PASS
		27033	848.3	27.89	22.10	5.79	≤13	PASS
	3	26805	825.5	28.66	22.46	6.20	≤13	PASS
		26915	836.5	28.65	22.53	6.12	≤13	PASS
		27025	847.5	27.84	22.10	5.74	≤13	PASS
	5	26815	826.5	28.65	22.53	6.12	≤13	PASS
		26915	836.5	28.62	22.57	6.05	≤13	PASS
		27015	846.5	28.01	22.26	5.75	≤13	PASS
	10	26840	829	28.53	22.46	6.07	≤13	PASS
		26915	836.5	28.57	22.50	6.07	≤13	PASS
		26990	844	28.24	22.23	6.01	≤13	PASS
15	26865	831.5	28.68	22.44	6.24	≤13	PASS	



		26915	836.5	28.64	22.45	6.19	≤13	PASS
		26965	841.5	28.49	22.40	6.09	≤13	PASS

## 5.5. Frequency Stability

### Ambient condition

Temperature	Relative humidity	Pressure
23°C ~25°C	45%~50%	101.5kPa

### Method of Measurement

#### Frequency Stability (Temperature Variation)

The temperature inside the climate chamber is varied from 0°C to +35°C in 10°C step size,

(1) With all power removed, the temperature was decreased to 0°C and permitted to stabilize for three hours.

(2) Measure the carrier frequency with the test equipment in a “call mode”. These measurements should be made within 1 minute of powering up the mobile station, to prevent significant self warming.

(3) Repeat the above measurements at 10°C increments from 0°C to +35°C. Allow at least 1.5 hours at each temperature, un-powered, before making measurements.

#### Frequency Stability (Voltage Variation)

The frequency stability shall be measured with variation of primary supply voltage as follows:

**Primary Supply Voltage:** The primary supply voltage is varied from 85% to 115% of the nominal value for non hand-carried battery and AC powered equipment. For hand-carried, battery-powered equipment, primary supply voltage is reduced to the battery operating end point which shall be specified by the manufacturer.

This transceiver is specified to operate with an input voltage of between 3.60 V and 4.45 V, with a nominal voltage of 3.87V.

### Test setup

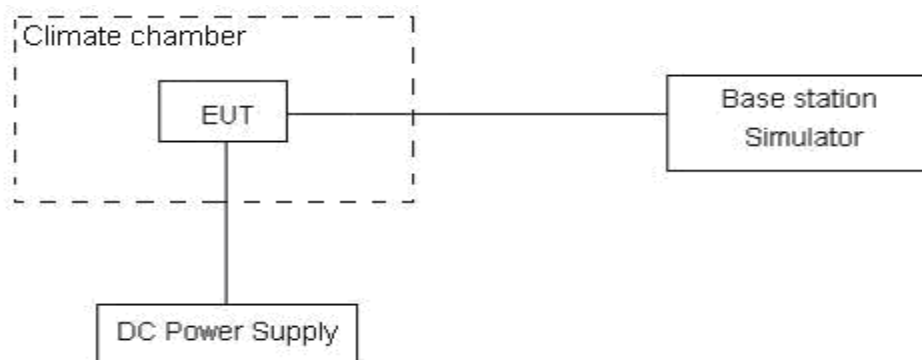

### Limits

According to the Sec. 22.355, the frequency stability of the carrier shall be accurate to within 2.5 ppm of the received frequency for mobile stations.

Limits	≤ 2.5 ppm
--------	-----------

### Measurement Uncertainty

The assessed measurement uncertainty to ensure 99.75% confidence level for the normal distribution is with the coverage factor  $k = 3$ ,  $U = 0.01\text{ppm}$ .





## Test Result

GSM 850						
Condition		Freq.Error (Hz)	Freq.Error (Hz)	Frequency Stability (ppm)	Frequency Stability (ppm)	Verdict
Temperature	Voltage	GMSK	8PSK	GMSK	8PSK	
Normal (25°C)	Normal	1.68	12.10	0.00201	0.01447	PASS
Extreme (35°C)		16.90	13.11	0.02020	0.01567	PASS
Extreme (30°C)		9.23	1.59	0.01103	0.00190	PASS
Extreme (20°C)		1.53	11.38	0.00183	0.01361	PASS
Extreme (10°C)		2.04	9.02	0.00244	0.01078	PASS
Extreme (0°C)		12.04	8.77	0.01439	0.01048	PASS
25°C	LV	10.70	4.03	0.01279	0.00482	PASS
	HV	12.83	17.14	0.01533	0.02048	PASS

WCDMA Band V						
Condition		Freq.Error (Hz)	Freq.Error (Hz)	Frequency Stability (ppm)	Frequency Stability (ppm)	Verdict
Temperature	Voltage	BPSK	QPSK	BPSK	QPSK	
Normal (25°C)	Normal	9.85	1.88	0.01178	0.00224	PASS
Extreme (35°C)		13.75	12.48	0.01644	0.01492	PASS
Extreme (30°C)		7.64	14.59	0.00913	0.01744	PASS
Extreme (20°C)		3.10	3.01	0.00370	0.00360	PASS
Extreme (10°C)		4.35	12.02	0.00520	0.01437	PASS
Extreme (0°C)		16.84	4.26	0.02013	0.00509	PASS
25°C	LV	10.96	11.33	0.01310	0.01354	PASS
	HV	6.32	17.26	0.00756	0.02064	PASS

LTE Band 5						
Condition		Freq.Error (Hz)	Freq.Error (Hz)	Frequency Stability (ppm)	Frequency Stability (ppm)	Verdict
BANDWIDTH	1.4MHz	16QAM	QPSK	16QAM	QPSK	
Temperature	Voltage	16QAM	QPSK	16QAM	QPSK	
Normal (25°C)	Normal	17.32	9.07	0.02070	0.01084	PASS
Extreme (35°C)		10.62	2.75	0.01269	0.00329	PASS
Extreme (30°C)		3.69	14.15	0.00441	0.01691	PASS
Extreme (20°C)		17.59	14.90	0.02102	0.01781	PASS
Extreme (10°C)		1.43	8.83	0.00171	0.01055	PASS
Extreme (0°C)		12.17	16.60	0.01455	0.01984	PASS



25°C	LV	6.58	9.76	0.00787	0.01167	PASS
	HV	4.37	7.39	0.00523	0.00883	PASS
Condition		Freq.Error (Hz)	Freq.Error (Hz)	Frequency Stability (ppm)	Frequency Stability (ppm)	Verdict
BANDWIDTH	3MHz					
Temperature	Voltage	16QAM	QPSK	16QAM	QPSK	
Normal (25°C)	Normal	15.11	10.29	0.01806	0.01230	PASS
Extreme (35°C)		3.14	6.23	0.00376	0.00745	PASS
Extreme (30°C)		7.71	4.33	0.00922	0.00517	PASS
Extreme (20°C)		6.73	16.37	0.00805	0.01957	PASS
Extreme (10°C)		2.41	1.21	0.00288	0.00145	PASS
Extreme (0°C)		15.47	12.44	0.01850	0.01487	PASS
25°C	LV	13.08	11.89	0.01564	0.01422	PASS
	HV	1.28	12.21	0.00153	0.01459	PASS
Condition		Freq.Error (Hz)	Freq.Error (Hz)	Frequency Stability (ppm)	Frequency Stability (ppm)	Verdict
BANDWIDTH	5MHz					
Temperature	Voltage	16QAM	QPSK	16QAM	QPSK	
Normal (25°C)	Normal	12.83	4.43	0.01533	0.00529	PASS
Extreme (35°C)		13.58	15.76	0.01623	0.01884	PASS
Extreme (30°C)		7.80	2.88	0.00933	0.00344	PASS
Extreme (20°C)		12.30	13.46	0.01471	0.01610	PASS
Extreme (10°C)		9.10	15.88	0.01088	0.01898	PASS
Extreme (0°C)		14.40	3.75	0.01721	0.00448	PASS
25°C	LV	7.25	1.49	0.00867	0.00179	PASS
	HV	1.39	14.03	0.00166	0.01677	PASS
Condition		Freq.Error (Hz)	Freq.Error (Hz)	Frequency Stability (ppm)	Frequency Stability (ppm)	Verdict
BANDWIDTH	10MHz					
Temperature	Voltage	16QAM	QPSK	16QAM	QPSK	
Normal (25°C)	Normal	1.21	17.16	0.00145	0.02051	PASS
Extreme (35°C)		3.51	6.21	0.00420	0.00743	PASS
Extreme (30°C)		8.73	4.14	0.01043	0.00495	PASS
Extreme (20°C)		13.16	16.15	0.01574	0.01931	PASS
Extreme (10°C)		4.45	14.20	0.00532	0.01698	PASS
Extreme (0°C)		5.37	1.43	0.00642	0.00171	PASS
25°C	LV	6.26	15.21	0.00748	0.01818	PASS
	HV	17.84	6.63	0.02132	0.00792	PASS

LTE Band 26						
Condition		Freq.Error (Hz)	Freq.Error (Hz)	Frequency Stability (ppm)	Frequency Stability (ppm)	Verdict
BANDWIDTH	1.4MHz					
Temperature	Voltage	16QAM	QPSK	16QAM	QPSK	
Normal (25°C)	Normal	6.60	2.99	0.00789	0.00358	PASS
Extreme (35°C)		12.38	16.89	0.01480	0.02019	PASS
Extreme (30°C)		14.08	17.27	0.01683	0.02065	PASS
Extreme (20°C)		6.19	5.73	0.00741	0.00684	PASS
Extreme (10°C)		1.53	1.89	0.00183	0.00226	PASS
Extreme (0°C)		17.26	13.89	0.02064	0.01661	PASS
25°C		LV	6.47	3.54	0.00774	0.00423
	HV	2.70	3.27	0.00323	0.00390	PASS
Condition		Freq.Error (Hz)	Freq.Error (Hz)	Frequency Stability (ppm)	Frequency Stability (ppm)	Verdict
BANDWIDTH	3MHz					
Temperature	Voltage	16QAM	QPSK	16QAM	QPSK	
Normal (25°C)	Normal	8.14	17.14	0.00973	0.02049	PASS
Extreme (35°C)		1.51	6.65	0.00180	0.00795	PASS
Extreme (30°C)		1.91	2.70	0.00228	0.00323	PASS
Extreme (20°C)		1.09	4.10	0.00130	0.00490	PASS
Extreme (10°C)		12.89	15.18	0.01541	0.01814	PASS
Extreme (0°C)		1.45	13.32	0.00174	0.01592	PASS
25°C		LV	16.16	9.35	0.01932	0.01117
	HV	11.29	12.58	0.01349	0.01504	PASS
Condition		Freq.Error (Hz)	Freq.Error (Hz)	Frequency Stability (ppm)	Frequency Stability (ppm)	Verdict
BANDWIDTH	5MHz					
Temperature	Voltage	16QAM	QPSK	16QAM	QPSK	
Normal (25°C)	Normal	5.84	1.47	0.00699	0.00175	PASS
Extreme (35°C)		13.23	1.80	0.01582	0.00215	PASS
Extreme (30°C)		14.42	15.95	0.01724	0.01907	PASS
Extreme (20°C)		14.73	5.64	0.01761	0.00675	PASS
Extreme (10°C)		6.31	6.71	0.00754	0.00802	PASS
Extreme (0°C)		6.54	2.72	0.00782	0.00325	PASS
25°C		LV	7.72	7.18	0.00923	0.00858
	HV	2.69	7.57	0.00322	0.00905	PASS
Condition		Freq.Error (Hz)	Freq.Error (Hz)	Frequency Stability (ppm)	Frequency Stability (ppm)	Verdict
BANDWIDTH	10MHz					
Temperature	Voltage	16QAM	QPSK	16QAM	QPSK	
Normal (25°C)	Normal	5.71	12.70	0.00683	0.01518	PASS



Extreme (35°C)		13.24	3.58	0.01582	0.00428	PASS
Extreme (30°C)		2.78	11.13	0.00333	0.01330	PASS
Extreme (20°C)		1.40	15.37	0.00167	0.01838	PASS
Extreme (10°C)		11.80	11.28	0.01411	0.01348	PASS
Extreme (0°C)		15.63	4.76	0.01869	0.00569	PASS
25°C	LV	10.34	17.33	0.01236	0.02072	PASS
	HV	1.40	2.80	0.00167	0.00334	PASS
Condition		Freq.Error (Hz)	Freq.Error (Hz)	Frequency Stability (ppm)	Frequency Stability (ppm)	Verdict
BANDWIDTH	15MHz					
Temperature	Voltage	16QAM	QPSK	16QAM	QPSK	
Normal (25°C)	Normal	10.40	16.63	0.01243	0.01987	PASS
Extreme (35°C)		4.00	3.99	0.00478	0.00478	PASS
Extreme (30°C)		2.47	8.17	0.00295	0.00976	PASS
Extreme (20°C)		16.93	14.90	0.02024	0.01782	PASS
Extreme (10°C)		7.55	4.87	0.00903	0.00583	PASS
Extreme (0°C)		1.08	16.36	0.00130	0.01956	PASS
25°C	LV	13.15	16.08	0.01572	0.01922	PASS
	HV	6.96	17.71	0.00832	0.02117	PASS

### 5.6. Spurious Emissions at Antenna Terminals

#### Ambient condition

Temperature	Relative humidity	Pressure
23°C ~25°C	45%~50%	101.5kPa

#### Method of Measurement

The EUT was connected to Spectrum Analyzer and Base Station Simulator via power Splitter. The measurement is carried out using a spectrum analyzer. The spectrum analyzer scans from 9kHz to the 10th harmonic of the carrier.

The peak detector is used. RBW are set to 100 kHz and VBW are set to 300 kHz for below 1G, RBW are set to 1MHz and VBW are set to 3MHz for above 1G, Sweep is set to ATUO.

RBW is set to 1 kHz (0.009MHz~ 0.15 MHz),

RBW is set to 10 kHz (0.15 MHz~ 30 MHz)

RBW is set to 100 kHz (30MHz~1000 MHz)

RBW is set to 1000 kHz (above 1000MHz)

The modulation mode and RB allocation refer to section 5.1, using the maximum output power configuration.

#### Test setup

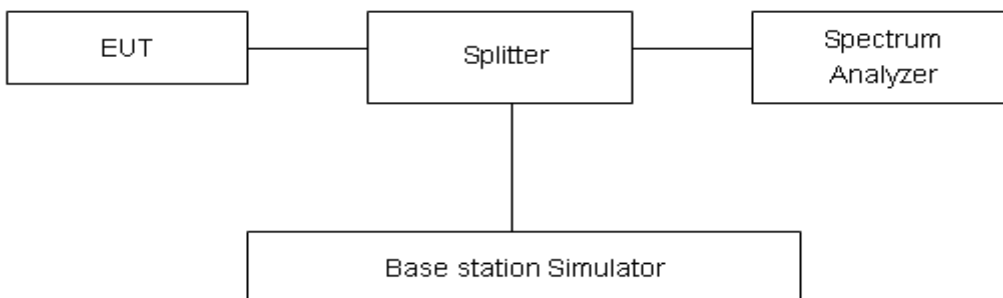

#### Limits

Rule Part 22.917(a) specifies that “The power of any emission outside of the authorized operating frequency ranges must be attenuated below the transmitting power (P) by a factor of at least 43 + 10 log (P) dB.”

Limit	-13 dBm

#### Measurement Uncertainty

The assessed measurement uncertainty to ensure 99.75% confidence level for the normal distribution is with the coverage factor  $k = 1.96$ .

Frequency	Uncertainty
9kHz-1GHz	0.684 dB
1GHz-20GHz	1.407 dB



### Test Result

Sweep the whole frequency band through the range from 9kHz to the 10th harmonic of the carrier, the emissions more than 20 dB below the limit are not reported.

The signal beyond the limit is carrier.

#### GSM 850 CH-Low 9kHz ~ 20GHz

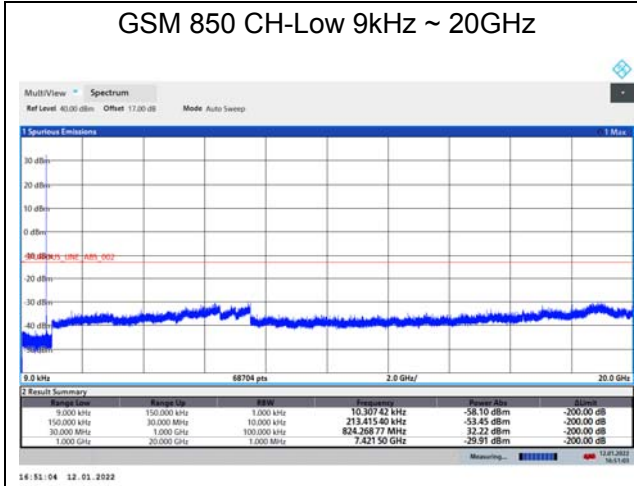

#### GPRS 850 CH-Low 9kHz ~ 20GHz

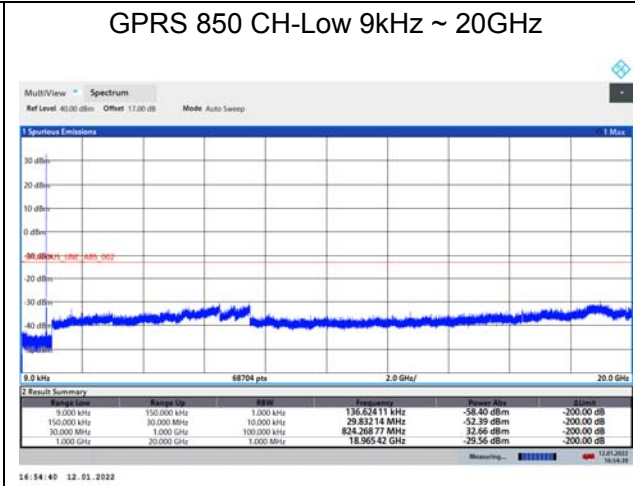

#### GSM 850 CH-Middle 9kHz ~ 20GHz

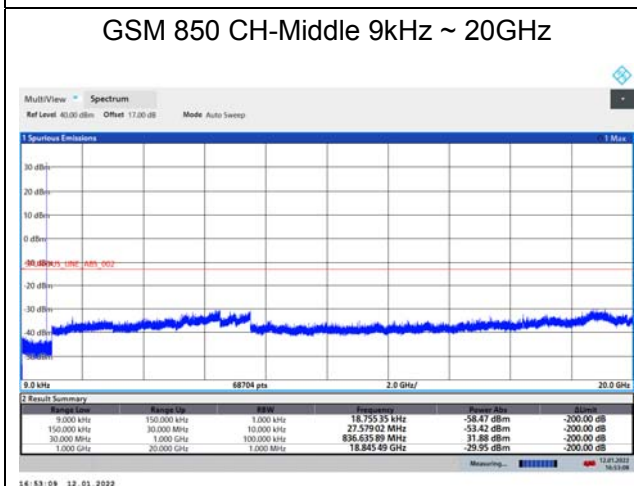

#### GPRS 850 CH-Middle 9kHz ~ 20GHz

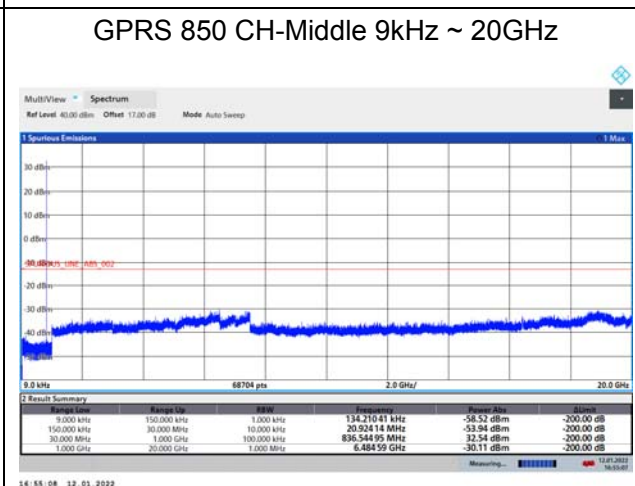

#### GSM 850 CH-High 9kHz ~ 20GHz

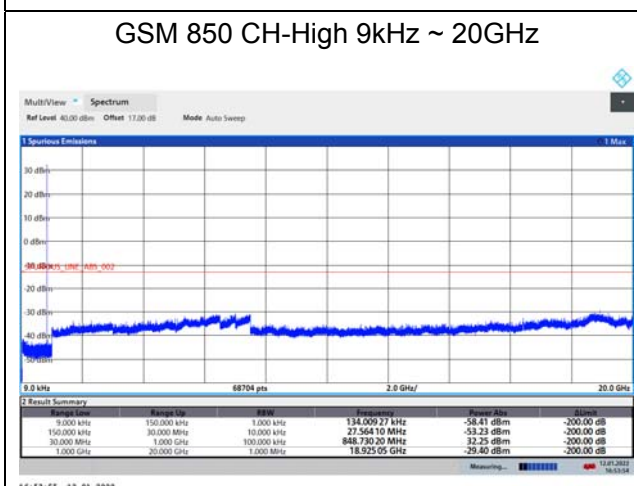

#### GPRS 850 CH-High 9kHz ~ 20GHz

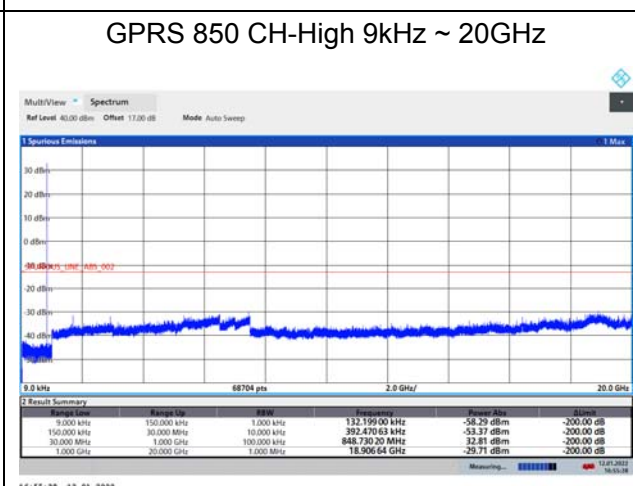



### EGPRS 850 CH-Low 9kHz ~ 20GHz

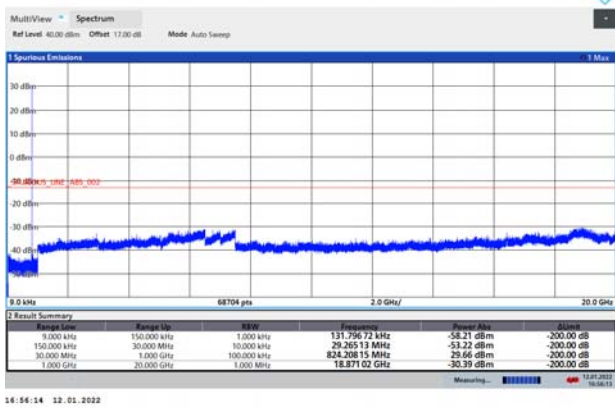

### WCDMA BAND V CH-Low 9kHz ~ 20GHz

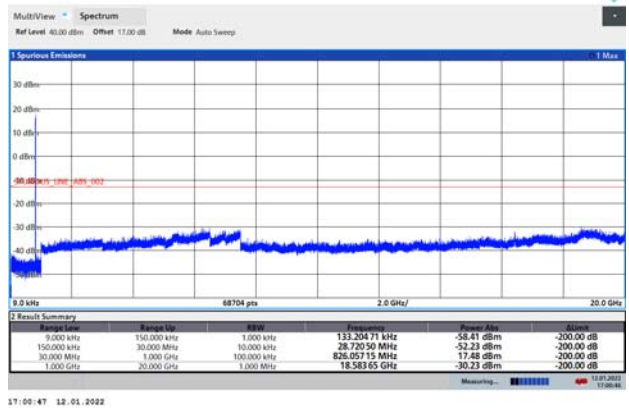

### EGPRS 850 CH-Middle 9kHz ~ 20GHz

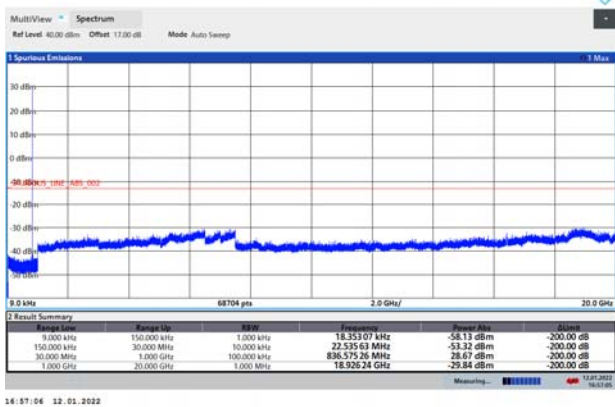

### WCDMA BAND V CH-Middle 9kHz ~ 20GHz

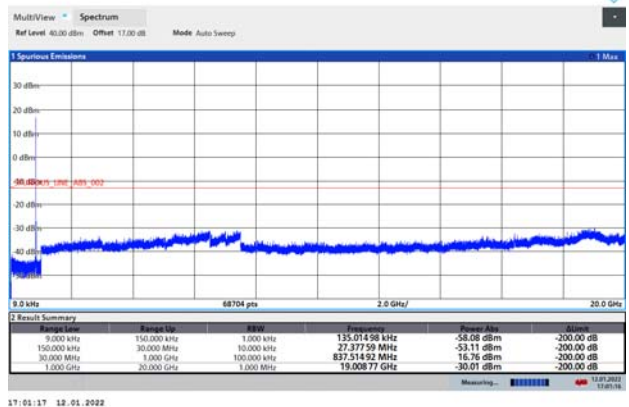

### EGPRS 850 CH-High 9kHz ~ 20GHz

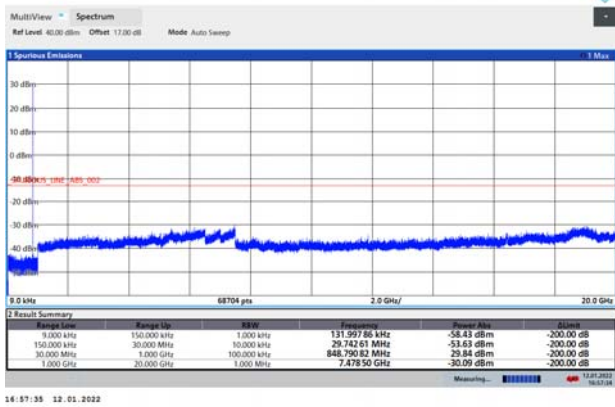

### WCDMA BAND V CH-High 9kHz ~ 20GHz

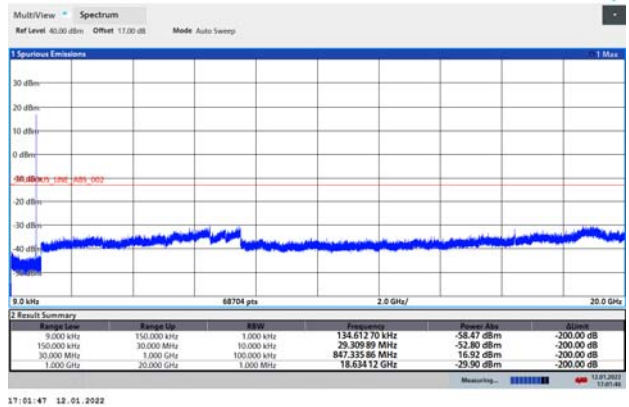

LTE Band 5 1.4MHz CH-Low 9kHz~10GHz

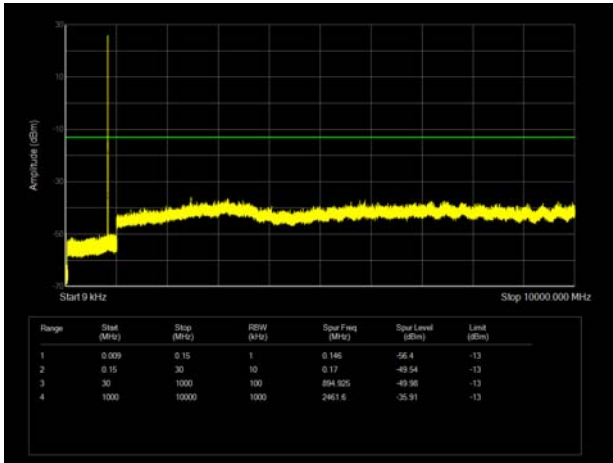

LTE Band 5 3MHz CH-Low 9kHz~10GHz

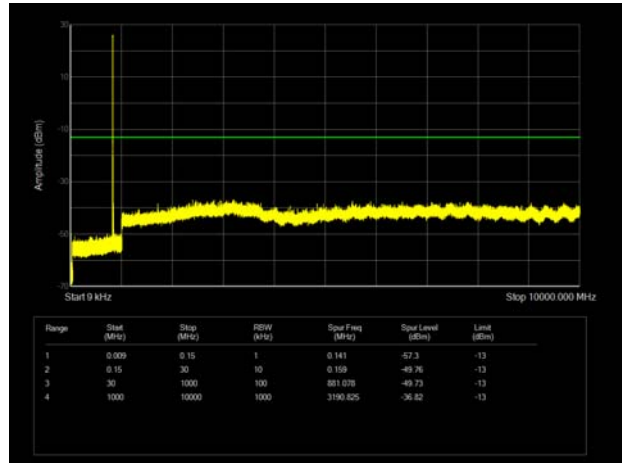

LTE Band 5 1.4MHz CH-Middle 9kHz~10GHz

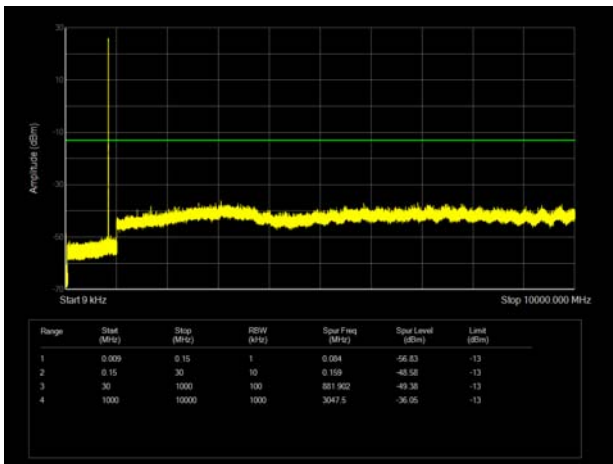

LTE Band 5 3MHz CH-Middle 9kHz~10GHz

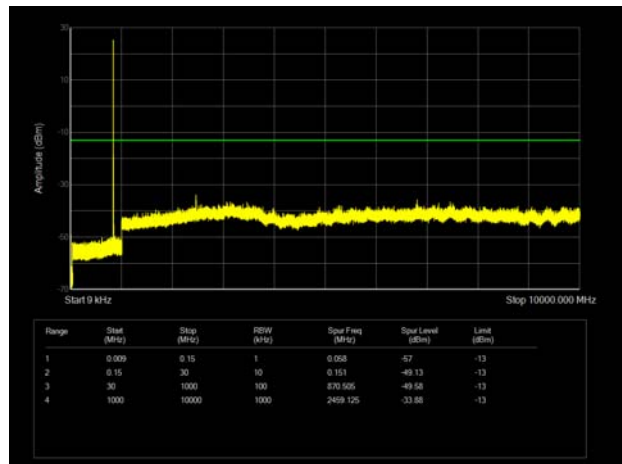

LTE Band 5 1.4MHz CH-High 9kHz~10GHz

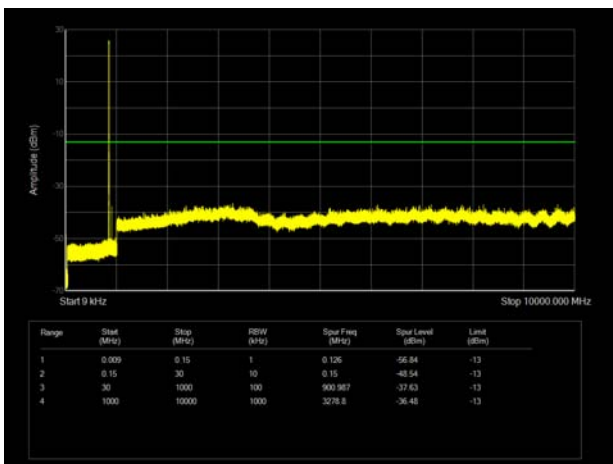

LTE Band 5 3MHz CH-High 9kHz~10GHz

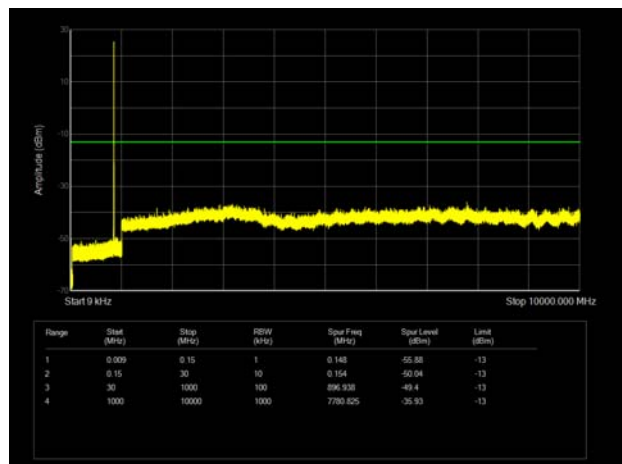



LTE Band 5 5MHz CH-Low 9kHz~10GHz

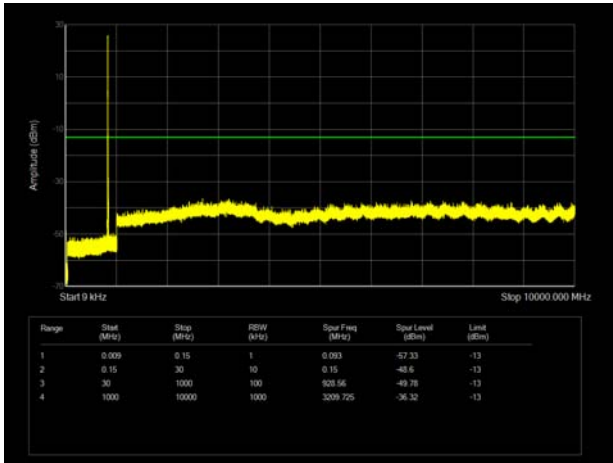

LTE Band 5 10MHz CH-Low 9kHz~10GHz

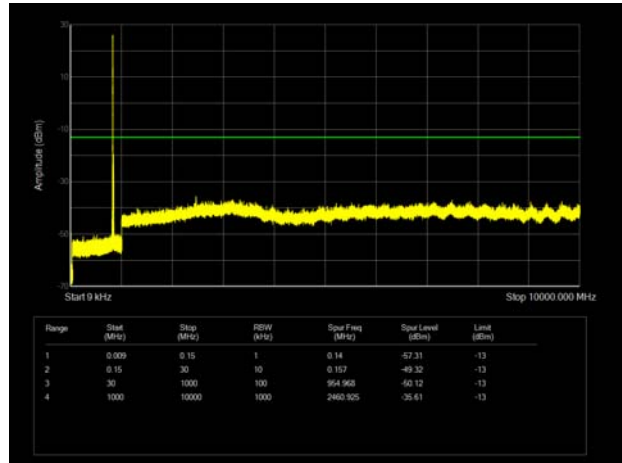

LTE Band 5 5MHz CH-Middle 9kHz~10GHz

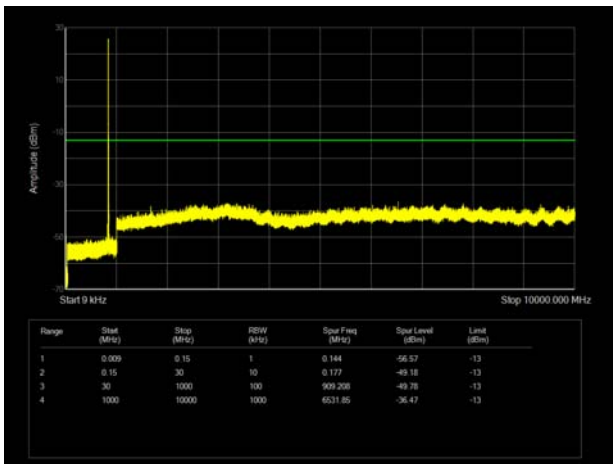

LTE Band 5 10MHz CH-Middle 9kHz~10GHz

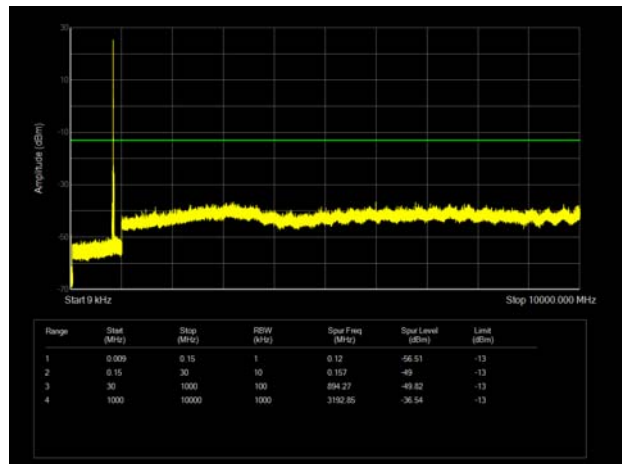

LTE Band 5 5MHz CH-High 9kHz~10GHz

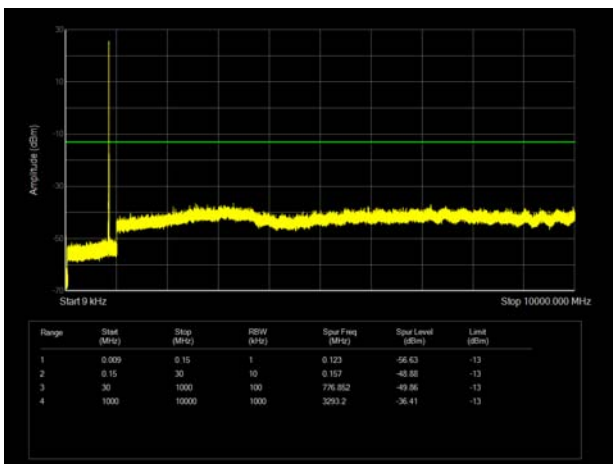

LTE Band 5 10MHz CH-High 9kHz~10GHz

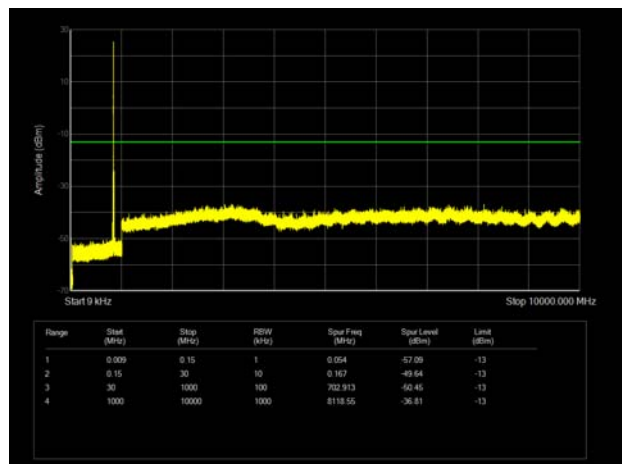

LTE Band 26 1.4MHz CH-Low 9kHz~10GHz

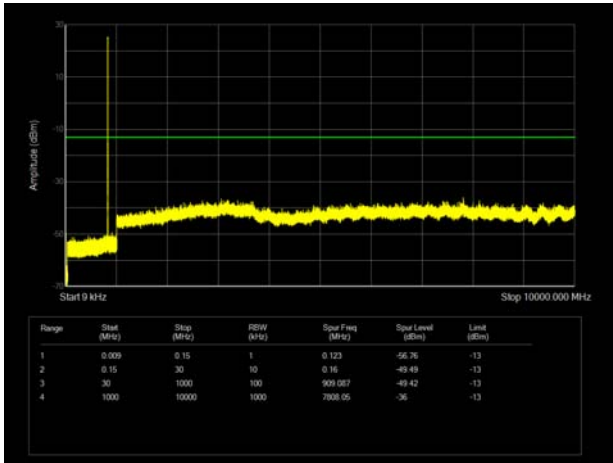

LTE Band 26 3MHz CH-Low 9kHz~10GHz

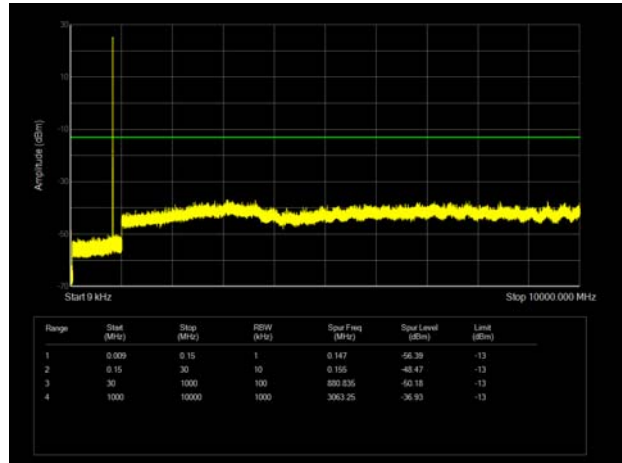

LTE Band 26 1.4MHz CH-Middle 9kHz~10GHz

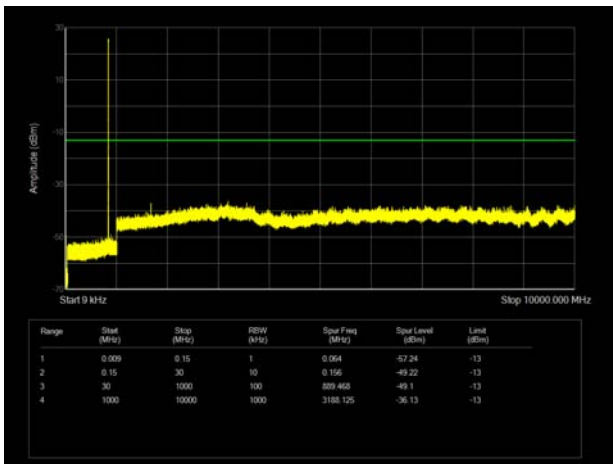

LTE Band 26 3MHz CH-Middle 9kHz~10GHz

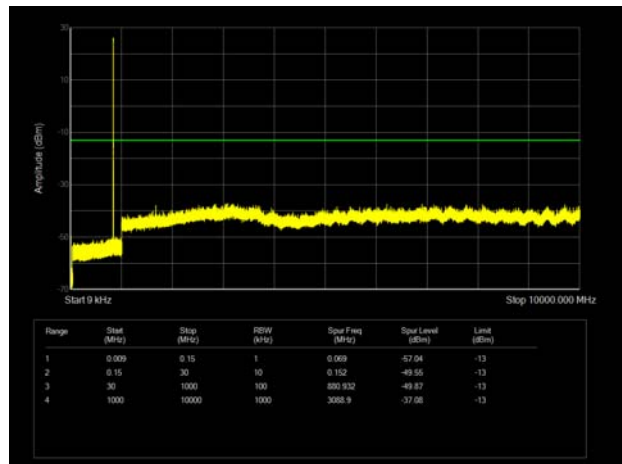

LTE Band 26 1.4MHz CH-High 9kHz~10GHz

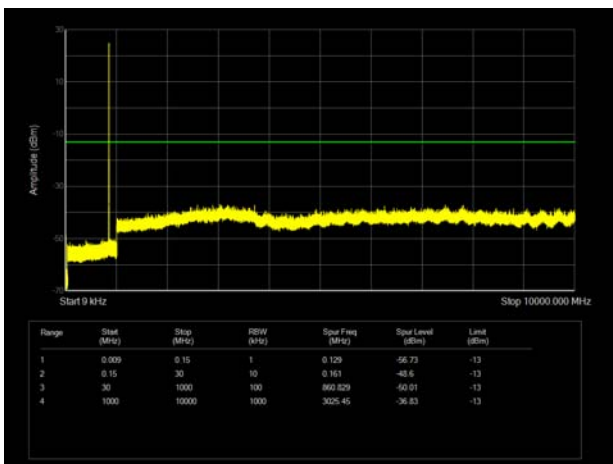

LTE Band 26 3MHz CH-High 9kHz~10GHz

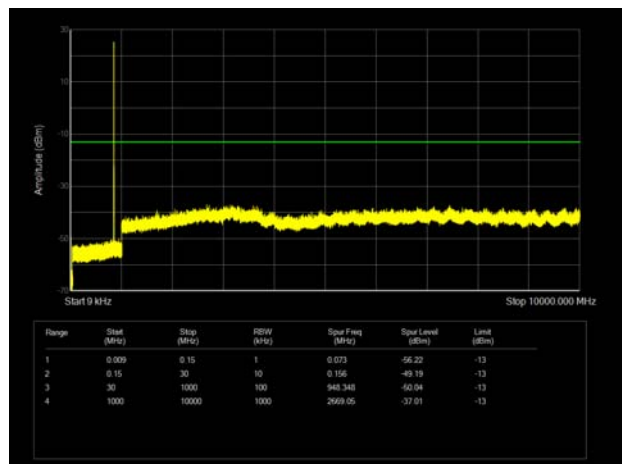

LTE Band 26 5MHz CH-Low 9kHz~10GHz

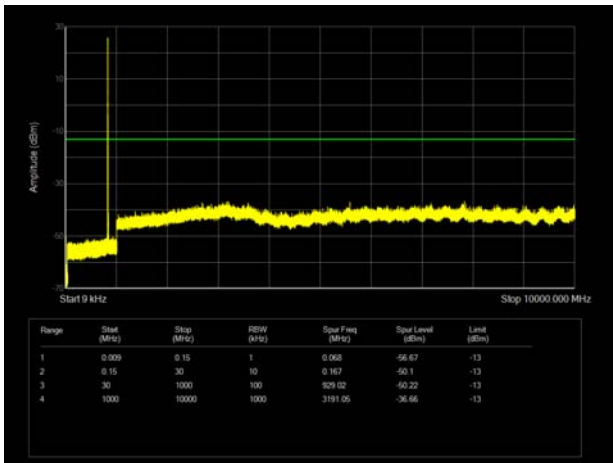

LTE Band 26 10MHz CH-Low 9kHz~10GHz

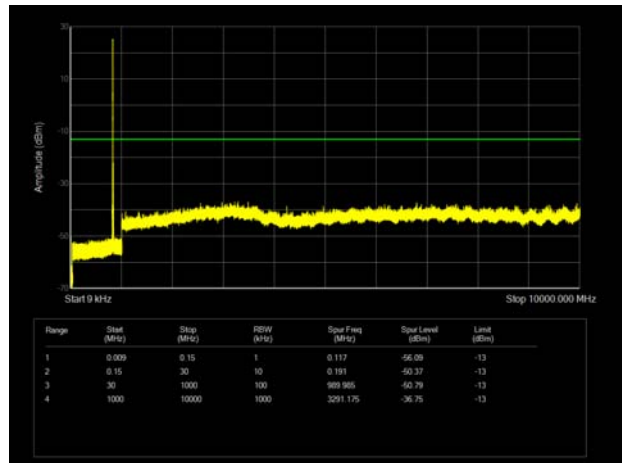

LTE Band 26 5MHz CH-Middle 9kHz~10GHz

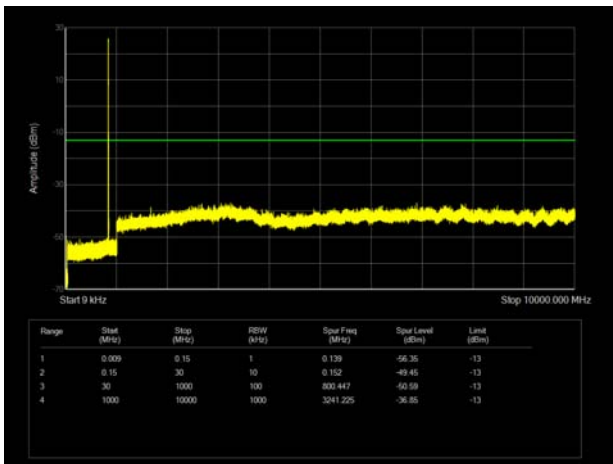

LTE Band 26 10MHz CH-Middle 9kHz~10GHz

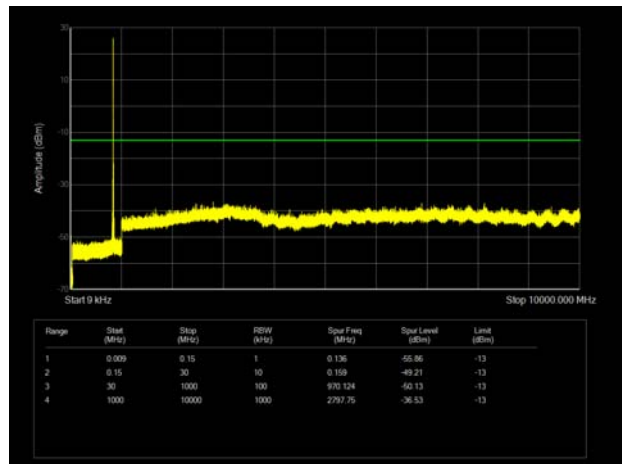

LTE Band 26 5MHz CH-High 9kHz~10GHz

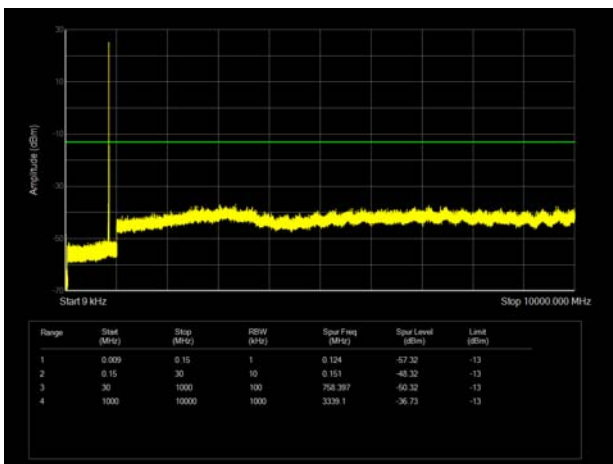

LTE Band 26 10MHz CH-High 9kHz~10GHz

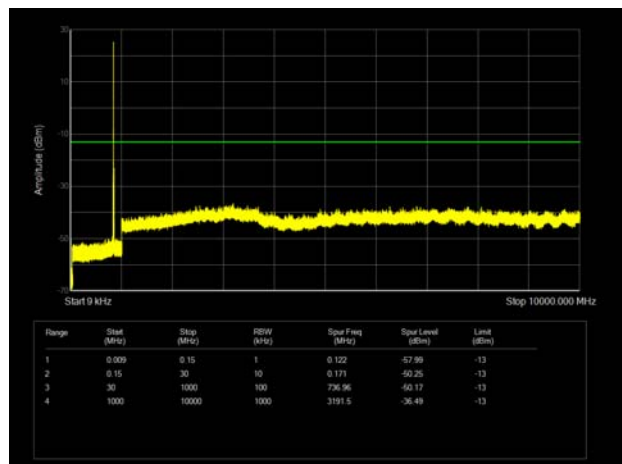

LTE Band 26 15MHz CH-Low 9kHz~10GHz

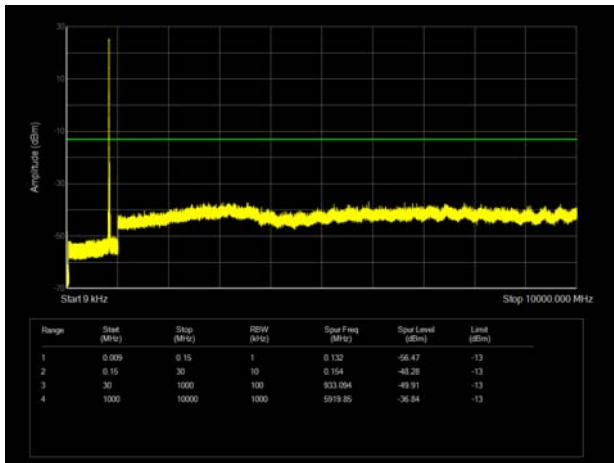

LTE Band 26 15MHz CH-Middle 9kHz~10GHz

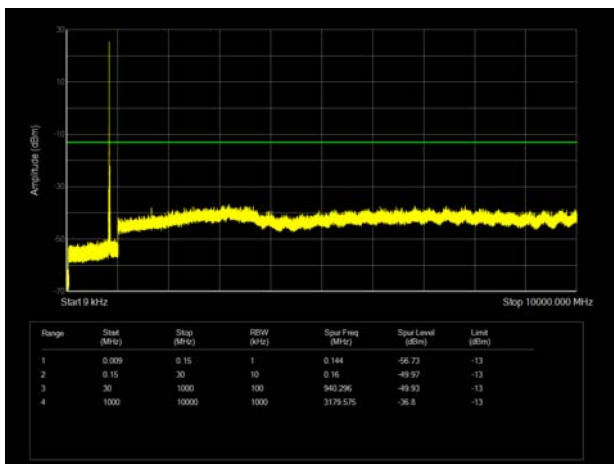

LTE Band 26 15MHz CH-High 9kHz~10GHz

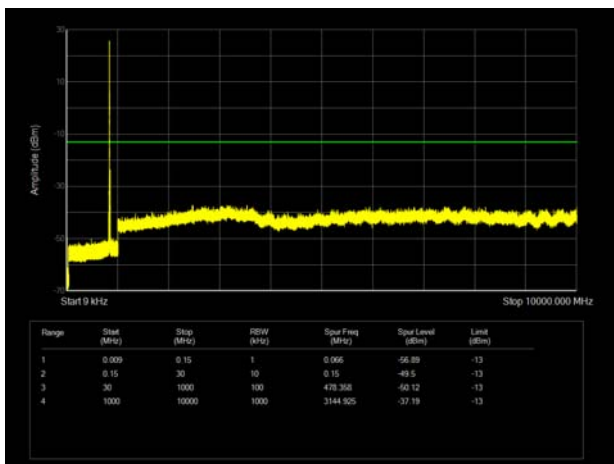

## 5.7. Radiates Spurious Emission

### Ambient condition

Temperature	Relative humidity	Pressure
23°C ~25°C	45%~50%	101.5kPa

### Method of Measurement

1. The testing follows FCC KDB 971168 v03r01 Section 5.8 and ANSI C63.26 (2015).
2. Below 1GHz: The EUT is placed on a turntable 0.8 meters above the ground in the chamber, 3 meter away from the antenna. The maximal emission value is acquired by adjusting the antenna height, polarisation and turntable azimuth. Normally, the height range of antenna is 1 m to 4 m, the azimuth range of turntable is 0° to 360°, and the receive antenna has two polarizations Vertical (V) and Horizontal (H). Above 1GHz: (Note: the FCC's permission to use 1.5m as an alternative per TCBC Conf call of Dec. 2, 2014.) The EUT is placed on a turntable 1.5 meters above the ground in the chamber, 3 meter away from the antenna. The maximal emission value is acquired by adjusting the antenna height, polarisation and turntable azimuth. Normally, the height range of antenna is 1 m to 4 m, the azimuth range of turntable is 0° to 360°, and the receive antenna has two polarizations Vertical (V) and Horizontal (H).
3. A loop antenna, A log-periodic antenna or horn antenna shall be substituted in place of the EUT. The log-periodic antenna will be driven by a signal generator and the level will be adjusted till the same power value on the spectrum analyzer or receiver. The level of the spurious emissions can be calculated through the level of the signal generator, cable loss, the gain of the substitution antenna and the reading of the spectrum analyzer or receiver.
4. The EUT is then put into continuously transmitting mode at its maximum power level during the test. Set Test Receiver or Spectrum RBW=100kHz, VBW=300kHz for 30MHz to 1GHz and RBW=1MHz, VBW=3MHz for above 1GHz, and the maximum value of the receiver should be recorded as (Pr).
5. The EUT shall be replaced by a substitution antenna. In the chamber, an substitution antenna for the frequency band of interest is placed at the reference point of the chamber. An RF Signal source for the frequency band of interest is connected to the substitution antenna with a cable that has been constructed to not interfere with the radiation pattern of the antenna. A power (PMea) is applied to the input of the substitution antenna, and adjust the level of the signal generator output until the value of the receiver reach the previously recorded (Pr). The power of signal source (PMea) is recorded. The test should be performed by rotating the test item and adjusting the receiving antenna polarization.
6. A amplifier should be connected to the Signal Source output port. And the cable should be connect between the Amplifier and the Substitution Antenna. The cable loss (Pcl), the Substitution Antenna Gain (Ga) and the Amplifier Gain (PAg) should be recorded after test.
7. The measurement results are obtained as described below:  
Power(EIRP)=PMea- PAg - Pcl + Ga  
The measurement results are amend as described below:  
Power(EIRP)=PMea- Pcl + Ga
8. This value is EIRP since the measurement is calibrated using an antenna of known gain (2.15 dB) and known input power. ERP can be calculated from EIRP by subtracting the gain of the dipole, ERP

= EIRP-2.15dB.

The modulation mode and RB allocation refer to section 5.1, using the maximum output power configuration.

**Test setup**

**9KHz ~ 30MHz**

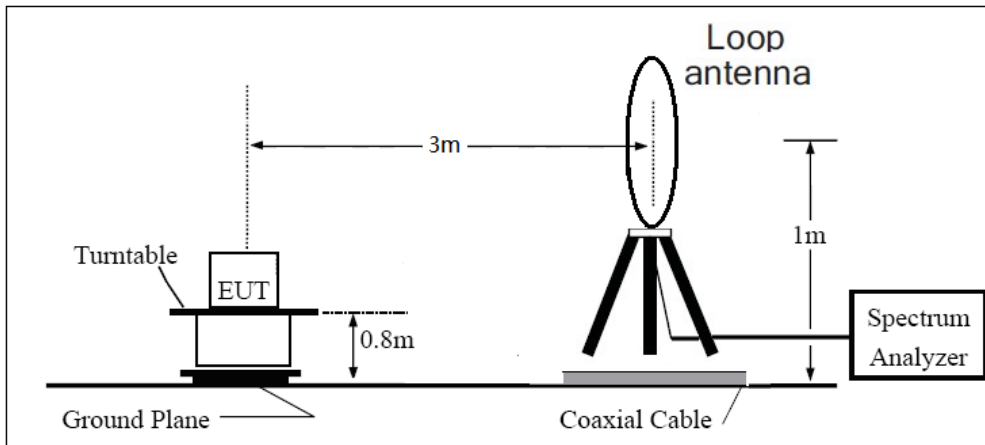

**30MHz ~ 1GHz**

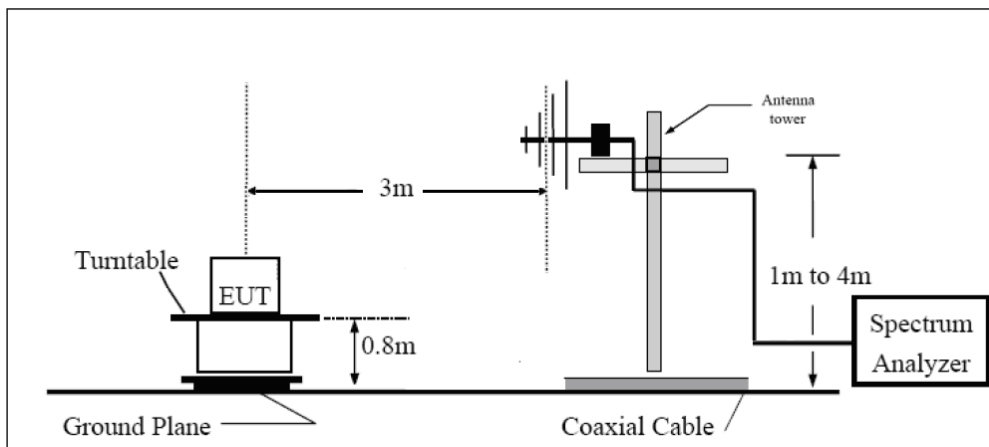

**Above 1GHz**

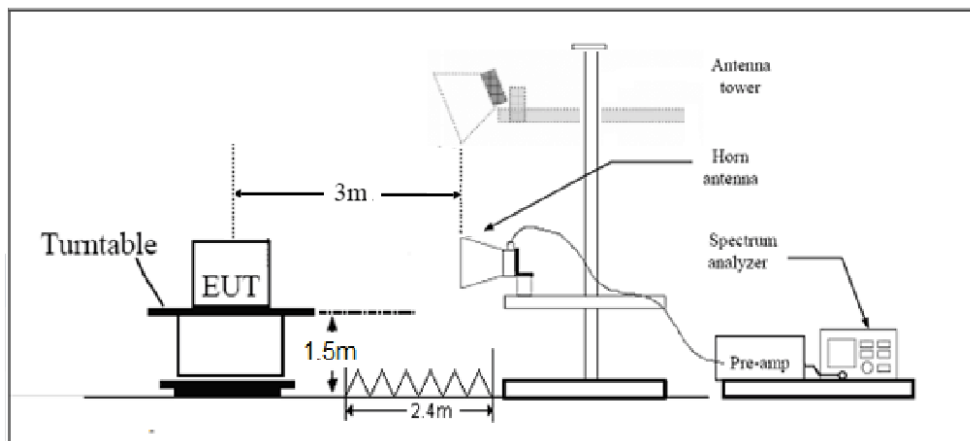

Note: Area side:2.4mX3.6m

### Limits

Rule Part 22.917(a) specifies that “The power of any emission outside of the authorized operating frequency ranges must be attenuated below the transmitting power (P) by a factor of at least  $43 + 10 \log (P)$  dB.”

Limit	-13 dBm
-------	---------

### Measurement Uncertainty

The assessed measurement uncertainty to ensure 95% confidence level for the normal distribution is with the coverage factor  $k = 1.96$ ,  $U = 3.55$  dB.

**Test Result**

Sweep the whole frequency band through the range from 9kHz to the 10th harmonic of the carrier, the emissions below the noise floor will not be recorded in the report.

**Main Antenna**

GSM 850 CH-Middle

Harmonic	Frequency (MHz)	SG (dBm)	Cable Loss (dB)	Gain (dBi)	Antenna Polarization	ERP Level (dBm)	Limit (dBm)	Margin (dB)	Azimuth (deg)
2	1672.50	-67.80	1.70	8.70	Horizontal	-62.95	-13.00	49.95	0
3	2509.90	-61.34	2.30	12.00	Horizontal	-53.79	-13.00	40.79	45
4	3346.40	-65.78	2.70	12.70	Horizontal	-57.93	-13.00	44.93	180
5	4183.00	-63.04	3.00	12.50	Horizontal	-55.69	-13.00	42.69	90
6	5019.60	-59.37	3.40	12.50	Horizontal	-52.42	-13.00	39.42	315
7	5856.20	-60.70	3.40	12.80	Horizontal	-53.45	-13.00	40.45	225
8	6692.80	-57.18	4.10	11.50	Horizontal	-51.93	-13.00	38.93	90
9	7529.40	-54.65	4.20	12.20	Horizontal	-48.80	-13.00	35.80	135
10	8366.00	-55.60	4.30	12.50	Horizontal	-49.55	-13.00	36.55	315

Note: 1.The other Spurious RF Radiated emissions level is no more than noise floor.

2.The worst emission was found in the antenna is Horizontal position.

## WCDMA Band V CH-Middle

Harmonic	Frequency (MHz)	SG (dBm)	Cable Loss (dB)	Gain (dBi)	Antenna Polarization	ERP Level (dBm)	Limit (dBm)	Margin (dB)	Azimuth (deg)
2	1673.20	-69.69	1.70	8.70	Horizontal	-64.84	-13.00	51.84	45
3	2509.80	-66.89	2.30	12.00	Horizontal	-59.34	-13.00	46.34	225
4	3346.40	-65.87	2.70	12.70	Horizontal	-58.02	-13.00	45.02	0
5	4183.00	-62.42	3.00	12.50	Horizontal	-55.07	-13.00	42.07	270
6	5019.60	-60.40	3.40	12.50	Horizontal	-53.45	-13.00	40.45	135
7	5856.20	-60.58	3.40	12.80	Horizontal	-53.33	-13.00	40.33	270
8	6692.80	-57.19	4.10	11.50	Horizontal	-51.94	-13.00	38.94	45
9	7529.40	-54.97	4.20	12.20	Horizontal	-49.12	-13.00	36.12	315
10	8366.00	-55.61	4.30	12.50	Horizontal	-49.56	-13.00	36.56	270

Note: 1.The other Spurious RF Radiated emissions level is no more than noise floor.

2.The worst emission was found in the antenna is Horizontal position.





## LTE Band 5 1.4MHz CH-Middle

Harmonic	Frequency (MHz)	SG (dBm)	Cable Loss (dB)	Gain (dBi)	Antenna Polarization	ERP Level (dBm)	Limit (dBm)	Margin (dB)	Azimuth (deg)
2	1673.00	-64.83	1.70	8.70	Horizontal	-59.98	-13.00	46.98	225
3	2509.50	-63.83	2.30	12.00	Horizontal	-56.28	-13.00	43.28	45
4	3346.00	-66.01	2.70	12.70	Horizontal	-58.16	-13.00	45.16	90
5	4182.50	-61.86	3.00	12.50	Horizontal	-54.51	-13.00	41.51	180
6	5019.00	-59.75	3.40	12.50	Horizontal	-52.80	-13.00	39.80	270
7	5855.50	-58.81	3.40	12.80	Horizontal	-51.56	-13.00	38.56	270
8	6692.00	-57.83	4.10	11.50	Horizontal	-52.58	-13.00	39.58	270
9	7528.50	-55.85	4.20	12.20	Horizontal	-50.00	-13.00	37.00	45
10	8365.00	-56.00	4.30	12.50	Horizontal	-49.95	-13.00	36.95	135

Note: 1.The other Spurious RF Radiated emissions level is no more than noise floor.  
2.The worst emission was found in the antenna is Horizontal position.

## LTE Band 5 5MHz CH-Middle

Harmonic	Frequency (MHz)	SG (dBm)	Cable Loss (dB)	Gain (dBi)	Antenna Polarization	ERP Level (dBm)	Limit (dBm)	Margin (dB)	Azimuth (deg)
2	1668.60	-65.40	1.70	8.70	Horizontal	-60.55	-13.00	47.55	135
3	2503.30	-64.43	2.30	12.00	Horizontal	-56.88	-13.00	43.88	90
4	3466.20	-65.21	2.70	12.70	Horizontal	-57.36	-13.00	44.36	0
5	4215.90	-63.54	3.00	12.50	Horizontal	-56.19	-13.00	43.19	135
6	5165.60	-57.85	3.40	12.50	Horizontal	-50.90	-13.00	37.90	0
7	5815.30	-58.89	3.40	12.80	Horizontal	-51.64	-13.00	38.64	315
8	6765.00	-59.05	4.10	11.50	Horizontal	-53.80	-13.00	40.80	0
9	7614.70	-56.55	4.20	12.20	Horizontal	-50.70	-13.00	37.70	0
10	8464.40	-56.14	4.30	12.50	Horizontal	-50.09	-13.00	37.09	180

Note: 1.The other Spurious RF Radiated emissions level is no more than noise floor.  
2.The worst emission was found in the antenna is Horizontal position.

LTE Band 5 10MHz CH-Middle

Harmonic	Frequency (MHz)	SG (dBm)	Cable Loss (dB)	Gain (dBi)	Antenna Polarization	ERP Level (dBm)	Limit (dBm)	Margin (dB)	Azimuth (deg)
2	1664.40	-65.53	1.70	8.70	Horizontal	-60.68	-13.00	47.68	225
3	2496.60	-65.21	2.30	12.00	Horizontal	-57.66	-13.00	44.66	90
4	3346.00	-65.68	2.70	12.70	Horizontal	-57.83	-13.00	44.83	135
5	4182.50	-62.24	3.00	12.50	Horizontal	-54.89	-13.00	41.89	315
6	5019.00	-58.23	3.40	12.50	Horizontal	-51.28	-13.00	38.28	0
7	5855.50	-58.45	3.40	12.80	Horizontal	-51.20	-13.00	38.20	180
8	6692.00	-57.51	4.10	11.50	Horizontal	-52.26	-13.00	39.26	270
9	7528.50	-55.85	4.20	12.20	Horizontal	-50.00	-13.00	37.00	135
10	8365.00	-55.82	4.30	12.50	Horizontal	-49.77	-13.00	36.77	180

Note: 1.The other Spurious RF Radiated emissions level is no more than noise floor.  
 2.The worst emission was found in the antenna is Horizontal position.

LTE Band 26 1.4MHz CH-Middle

Harmonic	Frequency (MHz)	SG (dBm)	Cable Loss (dB)	Gain (dBi)	Antenna Polarization	ERP Level (dBm)	Limit (dBm)	Margin (dB)	Azimuth (deg)
2	1672.13	-65.40	1.70	8.70	Horizontal	-60.55	-13.00	47.55	225
3	2508.00	-64.09	2.30	12.00	Horizontal	-56.54	-13.00	43.54	45
4	3346.00	-66.24	2.70	12.70	Horizontal	-58.39	-13.00	45.39	180
5	4182.50	-63.43	3.00	12.50	Horizontal	-56.08	-13.00	43.08	90
6	5019.00	-59.85	3.40	12.50	Horizontal	-52.90	-13.00	39.90	135
7	5855.50	-59.72	3.40	12.80	Horizontal	-52.47	-13.00	39.47	180
8	6692.00	-59.30	4.10	11.50	Horizontal	-54.05	-13.00	41.05	90
9	7528.50	-55.09	4.20	12.20	Horizontal	-49.24	-13.00	36.24	135
10	8365.00	-56.29	4.30	12.50	Horizontal	-50.24	-13.00	37.24	135

Note: 1.The other Spurious RF Radiated emissions level is no more than noise floor.  
 2.The worst emission was found in the antenna is Horizontal position.

LTE Band 26 5MHz CH-Middle

Harmonic	Frequency (MHz)	SG (dBm)	Cable Loss (dB)	Gain (dBi)	Antenna Polarization	ERP Level (dBm)	Limit (dBm)	Margin (dB)	Azimuth (deg)
2	1668.75	-55.83	1.70	8.70	Horizontal	-50.98	-13.00	37.98	270
3	2502.94	-58.27	2.30	12.00	Horizontal	-50.72	-13.00	37.72	135
4	3346.00	-66.48	2.70	12.70	Horizontal	-58.63	-13.00	45.63	45
5	4182.50	-63.04	3.00	12.50	Horizontal	-55.69	-13.00	42.69	315
6	5019.00	-59.42	3.40	12.50	Horizontal	-52.47	-13.00	39.47	315
7	5855.50	-59.36	3.40	12.80	Horizontal	-52.11	-13.00	39.11	270
8	6692.00	-59.25	4.10	11.50	Horizontal	-54.00	-13.00	41.00	90
9	7528.50	-55.08	4.20	12.20	Horizontal	-49.23	-13.00	36.23	90
10	8365.00	-55.61	4.30	12.50	Horizontal	-49.56	-13.00	36.56	315

Note: 1.The other Spurious RF Radiated emissions level is no more than noise floor.  
 2.The worst emission was found in the antenna is Horizontal position.

LTE Band 26 10MHz CH-Middle

Harmonic	Frequency (MHz)	SG (dBm)	Cable Loss (dB)	Gain (dBi)	Antenna Polarization	ERP Level (dBm)	Limit (dBm)	Margin (dB)	Azimuth (deg)
2	1659.38	-65.07	1.70	8.70	Horizontal	-60.22	-13.00	47.22	135
3	2489.44	-66.70	2.30	12.00	Horizontal	-59.15	-13.00	46.15	45
4	3346.00	-66.12	2.70	12.70	Horizontal	-58.27	-13.00	45.27	225
5	4182.50	-63.44	3.00	12.50	Horizontal	-56.09	-13.00	43.09	45
6	5019.00	-58.98	3.40	12.50	Horizontal	-52.03	-13.00	39.03	0
7	5855.50	-59.06	3.40	12.80	Horizontal	-51.81	-13.00	38.81	0
8	6692.00	-58.37	4.10	11.50	Horizontal	-53.12	-13.00	40.12	0
9	7528.50	-55.30	4.20	12.20	Horizontal	-49.45	-13.00	36.45	90
10	8365.00	-55.41	4.30	12.50	Horizontal	-49.36	-13.00	36.36	315

Note: 1.The other Spurious RF Radiated emissions level is no more than noise floor.  
 2.The worst emission was found in the antenna is Horizontal position.

## 6. Main Test Instruments

Name	Manufacturer	Type	Serial Number	Calibration Date	Expiration Date
Base Station Simulator	R&S	CMW500	113645	2021-05-15	2022-05-14
Climate Chamber	Weiss	VT4002	58226119450 010	2021-05-15	2022-05-14
Spectrum Analyzer	Keysight	N9020A	MY52330084	2021-05-15	2022-05-14
Universal Radio Communication Tester	Key sight	E5515C	GB44400275	2021-05-15	2022-05-14
Signal Analyzer	R&S	FSV3030	101411	2021-12-12	2022-12-12
Signal Analyzer	R&S	FSV30	100815	2021-12-12	2022-12-11
TRILOG Broadband Antenna	Schwarzbeck	VULB 9163	01439	2021-06-30	2024-06-29
Horn Antenna	Schwarzbeck	BBHA 9120D	01799	2019-09-21	2022-09-20
Software	R&S	EMC32	9.26.0	/	/

\*\*\*\*\*END OF REPORT \*\*\*\*\*



## ANNEX A: The EUT Appearance

The EUT Appearance are submitted separately.



## **ANNEX B: Test Setup Photos**

The Test Setup Photos are submitted separately.



## **ANNEX C: Product Change Description**

The Product Change Description are submitted separately.