



# RF TEST REPORT

**Applicant** Honor Device Co., Ltd.  
**FCC ID** 2AYGCTFY-LX3  
**Product** Smart Phone  
**Model** TFY-LX3  
**Report No.** R2201A0036-R1V1  
**Issue Date** February 9, 2022

TA Technology (Shanghai) Co., Ltd. tested the above equipment in accordance with the requirements in **FCC CFR47 Part 2 (2020)/ FCC CFR 47 Part 22H (2020)**. The test results show that the equipment tested is capable of demonstrating compliance with the requirements as documented in this report.

Prepared by: Peng Tao

Approved by: Kai Xu

---

**TA Technology (Shanghai) Co., Ltd.**

No.145, Jintang Rd, Tangzhen Industry Park, Pudong Shanghai, China

TEL: +86-021-50791141/2/3

FAX: +86-021-50791141/2/3-8000

## TABLE OF CONTENT

1. Test Laboratory .....	5
1.1. Notes of the Test Report .....	5
1.2. Test facility .....	5
1.3. Testing Location .....	5
2. General Description of Equipment under Test.....	6
2.1. Applicant and Manufacturer Information .....	6
2.2. General Information.....	6
3. Applied Standards.....	8
4. Test Configuration.....	9
5. Test Case Results.....	11
5.1. RF Power Output and Effective Radiated Power .....	11
5.2. Occupied Bandwidth .....	20
5.3. Band Edge Compliance.....	45
5.4. Peak-to-Average Power Ratio (PAPR) .....	61
5.5. Frequency Stability.....	65
5.6. Spurious Emissions at Antenna Terminals .....	70
5.7. Radiates Spurious Emission .....	78
6. Main Test Instruments .....	85
ANNEX A: The EUT Appearance .....	86
ANNEX B: Test Setup Photos .....	87



Version	Revision description	Issue Date
Rev.0	Initial issue of report.	January 29, 2022
Rev.1	Update information in Page 6 and Page 7.	February 9, 2022

Note: This revised report (Report No. R2201A0036-R1V1) supersedes and replaces the previously issued report (Report No. R2201A0036-R1). Please discard or destroy the previously issued report and dispose of it accordingly.

### Summary of measurement results

No.	Test Case	Clause in FCC rules	Verdict
1	RF Power Output and Effective Radiated Power	2.1046 22.913(a)(5)	PASS
2	Occupied Bandwidth	2.1049	PASS
3	Band Edge Compliance	2.1051 / 22.917(a)	PASS
4	Peak-to-Average Power Ratio	22.913(d)/ KDB 971168 D01(5.7)	PASS
5	Frequency Stability	2.1055 / 22.355	PASS
6	Spurious Emissions at Antenna Terminals	2.1051 / 22.917(a)	PASS
7	Radiates Spurious Emission	2.1053 / 22.917 (a)	PASS

Date of Testing: January 13, 2022 ~ January 27, 2022

Date of Sample Received: January 10, 2022

Note: PASS: The EUT complies with the essential requirements in the standard.

FAIL: The EUT does not comply with the essential requirements in the standard.

All indications of Pass/Fail in this report are opinions expressed by TA Technology (Shanghai) Co., Ltd. based on interpretations and/or observations of test results. Measurement Uncertainties were not taken into account and are published for informational purposes only.

## 1. Test Laboratory

### 1.1. Notes of the Test Report

This report shall not be reproduced in full or partial, without the written approval of **TA technology (shanghai) co., Ltd.** The results documented in this report apply only to the tested sample, under the conditions and modes of operation as described herein. Measurement Uncertainties were not taken into account and are published for informational purposes only. This report is written to support regulatory compliance of the applicable standards stated above.

### 1.2. Test facility

#### **FCC (Designation number: CN1179, Test Firm Registration Number: 446626)**

TA Technology (Shanghai) Co., Ltd. has been listed on the US Federal Communications Commission list of test facilities recognized to perform measurements.

#### **A2LA (Certificate Number: 3857.01)**

TA Technology (Shanghai) Co., Ltd. has been listed by American Association for Laboratory Accreditation to perform measurement.

### 1.3. Testing Location

Company: TA Technology (Shanghai) Co., Ltd.  
Address: No.145, Jintang Rd, Tangzhen Industry Park, Pudong  
City: Shanghai  
Post code: 201201  
Country: P. R. China  
Contact: Xu Kai  
Telephone: +86-021-50791141/2/3  
Fax: +86-021-50791141/2/3-8000  
Website: <http://www.ta-shanghai.com>  
E-mail: [xukai@ta-shanghai.com](mailto:xukai@ta-shanghai.com)

## 2. General Description of Equipment under Test

### 2.1. Applicant and Manufacturer Information

Applicant	Honor Device Co., Ltd.
Applicant address	Shum Yip Sky Park, No. 8089, Hongli West Road, Shenzhen, China
Manufacturer	Honor Device Co., Ltd.
Manufacturer address	Shum Yip Sky Park, No. 8089, Hongli West Road, Shenzhen, China

### 2.2. General Information

EUT Description			
Model	TFY-LX3		
SN	A7NX011C22000163		
Hardware Version	HL6TFYM		
Software Version	4.2.0.35(C900E14R1P1)		
Power Supply	Battery / AC adapter		
Antenna Type	Internal Antenna		
Antenna Gain	Band	Main Antenna	Second Antenna
	GSM 850	-3.78 dBi	NA
	WCDMA Band V	-3.78dBi	NA
	LTE Band 5	-3.78 dBi	NA
Antenna Gain	LTE Band 26	-3.78 dBi	NA
	Test Mode(s)		
GSM 850; WCDMA Band V; LTE Band 5/26;			
Test Modulation			
(GSM/GPRS)GMSK, (EGPRS) GMSK/ 8PSK; (WCDMA) BPSK, QPSK,; (LTE) QPSK, 16QAM;			
GPRS Multislot Class	12		
EGPRS Multislot Class	12		
HSDPA UE Category	14		
HSUPA UE Category	6		
DC-HSDPA UE Category	24		
LTE Category	4		
Maximum E.R.P.	GSM 850:	27.21dBm	
	WCDMA Band V:	18.41dBm	
	LTE Band 5:	18.59dBm	
	LTE Band 26:	18.85dBm	
Rated Power Supply Voltage	3.87V		
Operating Voltage	Minimum: 3.60V    Maximum: 4.45V		
Operating Temperature	Lowest: 0°C    Highest: 35°C		



Testing Temperature		Lowest: 0°C Highest: 35°C		
Operating Frequency Range(s)		Band	Tx (MHz)	Rx (MHz)
		GSM850	824 ~ 849	869 ~ 894
		WCDMA Band V	824 ~ 849	869 ~ 894
		LTE Band 5	824 ~ 849	869 ~ 894
		LTE Band 26	824 ~ 849	869 ~ 894
<b>EUT Accessory</b>				
Accessory	Model	Manufacture	No.	
Adapter	HW-100225E00	Honor Device Co., Ltd. (Manufacturer:Huntkey)	1	
	HW-100225U00	Honor Device Co., Ltd. (Manufacturer:Huntkey)	2	
	HW-100225B00	Honor Device Co., Ltd. (Manufacturer:Huntkey)	3	
	HN-100225E00	Honor Device Co., Ltd. (Manufacturer: Salcomp)	4	
	HN-100225U00	Honor Device Co., Ltd. (Manufacturer: Salcomp)	5	
Battery	HB416492EFW	Honor Device Co., Ltd. (Manufacturer: Sunwoda Electronic Co.,LTD)	1	
	HB416492EFW	Honor Device Co., Ltd. (Manufacturer:NVT)	2	
Earphone	MEND1532B528A11	Jiangxi Lianchuang Hongsheng Electronic Co., LTD.	1	
	1293-3283-3.5mm-339	BOLUO COUNTY QUANCHENG ELECTRONIC CO.,LTD.	2	
	EPAB542-2WH05-DH	FOXCONN INTERCONNECT TECHNOLOGY LIMITED	3	
USB Cable	RY0002	NingBo Broad Telecommunication Co., Ltd.	1	
	AU2-CRO013HF	Freeport Resources Enterprises Corp.	2	
	2120-00001-0	MING JI ELECTRONICS CO., LTD.	3	
	L125UC007-CS-H	LUXSHARE PRECISION INDUSTRY CO., LTD.	4	
	CUDU01B-HC451-EH	FOXCONN INTERCONNECT TECHNOLOGY LIMITED	5	
<p>Note: 1. The EUT is sent from the applicant to TA and the information of the EUT is declared by the applicant.</p> <p>2. There are more than one Adapter, Battery, Earphone and USB Cable, each one should be applied throughout the compliance test respectively, however, only the worst case (Adapter 1, Battery 2, Earphone 1 and USB Cable 3) will be recorded in this report.</p>				

### 3. Applied Standards

According to the specifications of the manufacturer, it must comply with the requirements of the following standards:

**Test standards:**

**FCC CFR 47 Part 22H (2020)**

**FCC CFR47 Part 2 (2020)**

**Reference standard:**

**ANSI C63.26 (2015)**

**KDB 971168 D01 Power Meas License Digital Systems v03r01**



## 4. Test Configuration

Radiated measurements are performed by rotating the EUT in three different orthogonal test planes. EUT stand-up position (Z axis), lie-down position (X, Y axis). Receiver antenna polarization (horizontal and vertical), the worst emission was found in position (X axis, horizontal polarization for GSM/WCDMA Band (Main Antenna); Z axis, horizontal polarization for LTE Band (Main Antenna); Z axis, horizontal polarization for GSM/WCDMA Band (Second Antenna); Z axis, vertical polarization for LTE Band (Second Antenna) and the worst case was recorded.

All mode and data rates and positions and RB size and modulations were investigated. Subsequently, only the worst case emissions are reported.

The following testing in GSM/WCDMA/LTE is set based on the maximum RF Output Power.

Test modes are chosen to be reported as the worst case configuration below:

Test items	Modes/Modulation	
	GSM 850	WCDMA Band V
RF Power Output and Effective Radiated power	GSM GPRS EGPRS	RMC/AMR HSDPA/HSUPA DC-HSDPA
Occupied Bandwidth	GSM GPRS(1Tx slot) EGPRS(1Tx slot)	RMC
Band Edge Compliance	GSM GPRS(1Tx slot) EGPRS(1Tx slot)	RMC
Peak-to-Average Power Ratio	GSM GPRS(1Tx slot) EGPRS(1Tx slot)	RMC
Frequency Stability	GSM GPRS(1Tx slot) EGPRS(1Tx slot)	RMC
Spurious Emissions at Antenna Terminals	GSM	RMC
Radiates Spurious Emission	GSM	RMC



Test modes are chosen as the worst case configuration below for LTE Band 5/26

Test items	Modes	Bandwidth (MHz)					Modulation		RB			Test Channel		
		1.4	3	5	10	15	QPSK	16QAM	1	50%	100%	L	M	H
RF power output and Effective Radiated power	LTE 5	O	O	O	O	-	O	O	O	O	O	O	O	O
	LTE 26	O	O	O	O	O	O	O	O	O	O	O	O	O
Occupied Bandwidth	LTE 5	O	O	O	O	-	O	O	-	-	O	O	O	O
	LTE 26	O	O	O	O	O	O	O	-	-	O	O	O	O
Band Edge Compliance	LTE 5	O	O	O	O	-	O	O	O	-	O	O	-	O
	LTE 26	O	O	O	O	O	O	O	O	-	O	O	-	O
Peak-to-Average Power Ratio	LTE 5	O	O	O	O	-	O	O	-	-	O	O	O	O
	LTE 26	O	O	O	O	O	O	O	-	-	O	O	O	O
Frequency Stability	LTE 5	O	O	O	O	-	O	O	O	-	-	-	O	-
	LTE 26	O	O	O	O	O	O	O	O	-	-	-	O	-
Spurious Emissions at Antenna Terminals	LTE 5	O	O	O	O	-	O	-	O	-	-	O	O	O
	LTE 26	O	O	O	O	O	O	-	O	-	-	O	O	O
Radiates Spurious Emission	LTE 5	O	-	O	O	-	O	-	O	-	-	-	O	-
	LTE 26	O	-	O	-	O	O	-	O	-	-	-	O	-
Note	1. The mark "O" means that this configuration is chosen for testing. 2. The mark "-" means that this configuration is not testing.													

## 5. Test Case Results

### 5.1. RF Power Output and Effective Radiated Power

#### Ambient condition

Temperature	Relative humidity	Pressure
23°C ~25°C	45%~50%	101.5kPa

#### Methods of Measurement

During the process of the testing, The EUT was connected to the Base Station Simulator with a known loss. The EUT is controlled by the Base Station Simulator test set to ensure max power transmission with proper modulation.

ERP can then be calculated as follows:

$$\text{EIRP (dBm)} = \text{Output Power (dBm)} - \text{Losses (dB)} + \text{Antenna Gain (dBi)}$$

where:dBd refers to gain relative to an ideal dipole.

$$\text{EIRP (dBm)} = \text{ERP (dBm)} + 2.15 \text{ (dB)}.$$

#### Test Setup

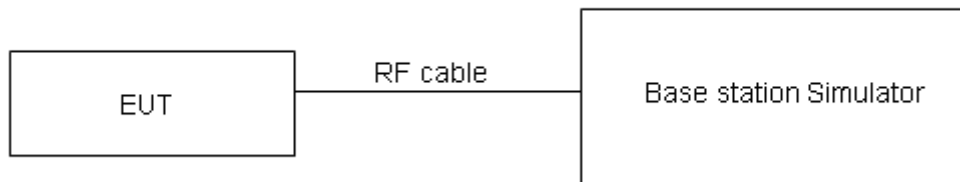

#### Limits

No specific RF power output requirements in part 2.1046.

Rule Part 22.913(a)(5) specifies that "Mobile/portable stations are limited to 7 watts ERP".

Limit	≤ 7 W (38.45 dBm)
-------	-------------------

#### Measurement Uncertainty

The assessed measurement uncertainty to ensure 95% confidence level for the normal distribution is with the coverage factor  $k = 2$ ,  $U = 0.4$  dB for RF power output,  $k = 2$ ,  $U = 1.19$  dB for ERP.

**Test Results**

<b>GSM 850</b>		<b>Maximum Output Power (dBm)</b>			<b>ERP (dBm)</b>		
		Channel 128	Channel 190	Channel 251	Channel 128	Channel 190	Channel 251
		824.2 (MHz)	836.6 (MHz)	848.8 (MHz)	824.2 (MHz)	836.6 (MHz)	848.8 (MHz)
GSM(GMSK)	Results	33.11	33.12	33.14	27.18	27.19	27.21
GPRS (GMSK)	1TXslot	32.93	33.10	33.02	27.00	27.17	27.09
	2TXslots	29.19	29.65	29.58	23.26	23.72	23.65
	3TXslots	26.81	27.48	27.35	20.88	21.55	21.42
	4TXslots	25.14	25.54	25.65	19.21	19.61	19.72
EGPRS	1TXslot	26.87	26.94	26.92	20.94	21.01	20.99
	2TXslots	23.81	24.47	23.84	17.88	18.54	17.91
	3TXslots	21.84	22.12	21.97	15.91	16.19	16.04
	4TXslots	20.25	20.53	20.03	14.32	14.60	14.10

<b>WCDMA Band V</b>		<b>Maximum Output Power (dBm)</b>			<b>ERP (dBm)</b>		
		Channel 4132	Channel 4183	Channel 4233	Channel 4132	Channel 4183	Channel 4233
		826.4 (MHz)	836.6 (MHz)	846.6 (MHz)	826.4 (MHz)	836.6 (MHz)	846.6 (MHz)
RMC		24.34	24.15	24.16	18.41	18.22	18.23
AMR		24.26	24.19	24.08	18.33	18.26	18.15
HSDPA	Sub - Test 1	23.52	23.29	23.48	17.59	17.36	17.55
	Sub - Test 2	23.38	23.37	23.48	17.45	17.44	17.55
	Sub - Test 3	23.04	23.01	22.94	17.11	17.08	17.01
	Sub - Test 4	22.92	22.93	22.78	16.99	17.00	16.85
HSUPA	Sub - Test 1	22.92	22.73	23.00	16.99	16.80	17.07
	Sub - Test 2	21.48	21.51	21.26	15.55	15.58	15.33
	Sub - Test 3	22.22	22.17	22.04	16.29	16.24	16.11
	Sub - Test 4	21.82	21.43	21.40	15.89	15.50	15.47
	Sub - Test 5	23.64	23.25	23.24	17.71	17.32	17.31
DC-HSDPA	Sub - Test 1	23.64	23.45	23.52	17.71	17.52	17.59
	Sub - Test 2	23.50	23.47	23.46	17.57	17.54	17.53
	Sub - Test 3	23.00	22.83	22.72	17.07	16.90	16.79
	Sub - Test 4	23.04	22.97	22.92	17.11	17.04	16.99

LTE Band 5				Maximum Output Power(dBm)			ERP (dBm)		
BW	Modulation	RB size	RB offset	Channel/Frequency(MHz)					
				20407 /824.7	20525 /836.5	20643 /848.3	20407 /824.7	20525 /836.5	20643 /848.3
1.4MHz	QPSK	1	0	24.45	24.46	24.33	18.52	18.53	18.40
		1	2	24.43	24.46	24.45	18.50	18.53	18.52
		1	5	24.04	24.18	23.99	18.11	18.25	18.06
		3	0	24.36	24.37	24.52	18.43	18.44	18.59
		3	2	24.30	24.29	24.29	18.37	18.36	18.36
		3	3	24.29	24.24	24.24	18.36	18.31	18.31
	16QAM	6	0	23.27	23.38	23.45	17.34	17.45	17.52
		1	0	23.88	23.84	23.91	17.95	17.91	17.98
		1	2	23.86	23.68	23.70	17.93	17.75	17.77
		1	5	23.51	23.39	23.29	17.58	17.46	17.36
		3	0	23.28	23.35	23.56	17.35	17.42	17.63
		3	2	23.30	23.25	23.37	17.37	17.32	17.44
		3	3	23.24	23.35	23.40	17.31	17.42	17.47
		6	0	22.34	22.40	22.40	16.41	16.47	16.47
BW	Modulation	RB size	RB offset	Channel/Frequency(MHz)					
				20415 /825.5	20525 /836.5	20635 /847.5	20415 /825.5	20525 /836.5	20635 /847.5
3MHz	QPSK	1	0	24.46	24.49	24.35	18.53	18.56	18.42
		1	7	24.42	24.50	24.50	18.49	18.57	18.57
		1	14	24.06	24.22	24.02	18.13	18.29	18.09
		8	0	23.46	23.49	23.65	17.53	17.56	17.72
		8	4	23.43	23.40	23.40	17.50	17.47	17.47
		8	7	23.39	23.37	23.35	17.46	17.44	17.42
	16QAM	15	0	23.31	23.43	23.50	17.38	17.50	17.57
		1	0	23.90	23.85	23.93	17.97	17.92	18.00
		1	7	23.89	23.70	23.74	17.96	17.77	17.81
		1	14	23.53	23.43	23.31	17.60	17.50	17.38
		8	0	22.40	22.49	22.69	16.47	16.56	16.76
		8	4	22.40	22.37	22.48	16.47	16.44	16.55
		8	7	22.34	22.47	22.53	16.41	16.54	16.60
		15	0	22.38	22.45	22.42	16.45	16.52	16.49



BW	Modulation	RB size	RB offset	Channel/Frequency(MHz)					
				20425 /826.5	20525 /836.5	20625 /846.5	20425 /826.5	20525 /836.5	20625 /846.5
5MHz	QPSK	1	0	24.45	24.45	24.33	18.52	18.52	18.40
		1	13	24.40	24.49	24.47	18.47	18.56	18.54
		1	24	24.03	24.17	23.98	18.10	18.24	18.05
		12	0	23.44	23.45	23.62	17.51	17.52	17.69
		12	6	23.40	23.35	23.36	17.47	17.42	17.43
		12	13	23.36	23.34	23.31	17.43	17.41	17.38
		25	0	23.29	23.39	23.45	17.36	17.46	17.52
	16QAM	1	0	23.85	23.83	23.91	17.92	17.90	17.98
		1	13	23.87	23.67	23.72	17.94	17.74	17.79
		1	24	23.50	23.39	23.28	17.57	17.46	17.35
		12	0	22.37	22.47	22.66	16.44	16.54	16.73
		12	6	22.37	22.32	22.44	16.44	16.39	16.51
		12	13	22.32	22.43	22.50	16.39	16.50	16.57
		25	0	22.35	22.40	22.38	16.42	16.47	16.45
BW	Modulation	RB size	RB offset	Channel/Frequency(MHz)					
				20450 /829	20525 /836.5	20600 /844	20450 /829	20525 /836.5	20600 /844
10MHz	QPSK	1	0	24.42	24.41	24.30	18.49	18.48	18.37
		1	25	24.39	24.44	24.45	18.46	18.51	18.52
		1	49	24.01	24.16	23.95	18.08	18.23	18.02
		25	0	23.41	23.40	23.58	17.48	17.47	17.65
		25	13	23.38	23.31	23.33	17.45	17.38	17.40
		25	25	23.33	23.29	23.27	17.40	17.36	17.34
		50	0	23.26	23.34	23.41	17.33	17.41	17.48
	16QAM	1	0	23.77	23.79	23.86	17.84	17.86	17.93
		1	25	23.83	23.65	23.68	17.90	17.72	17.75
		1	49	23.48	23.36	23.26	17.55	17.43	17.33
		25	0	22.34	22.43	22.63	16.41	16.50	16.70
		25	13	22.34	22.30	22.41	16.41	16.37	16.48
		25	25	22.29	22.38	22.46	16.36	16.45	16.53
		50	0	22.33	22.36	22.35	16.40	16.43	16.42

LTE Band 26							
Bandwidth (MHz)	UL Channel	RB Size	RB Position	Modulation	Power (dBm)	ERP (dBm)	Verdict
1.4	26797	1	#0	QPSK	24.49	18.56	PASS
1.4	26797	1	#Mid	QPSK	24.56	18.63	PASS
1.4	26797	1	#Max	QPSK	24.49	18.56	PASS
1.4	26797	3	#0	QPSK	24.47	18.54	PASS
1.4	26797	3	#Mid	QPSK	24.55	18.62	PASS
1.4	26797	3	#Max	QPSK	24.51	18.58	PASS
1.4	26797	6	#0	QPSK	23.73	17.80	PASS
1.4	26797	1	#0	QAM16	23.62	17.69	PASS
1.4	26797	1	#Mid	QAM16	23.65	17.72	PASS
1.4	26797	1	#Max	QAM16	23.65	17.72	PASS
1.4	26797	3	#0	QAM16	23.91	17.98	PASS
1.4	26797	3	#Mid	QAM16	23.94	18.01	PASS
1.4	26797	3	#Max	QAM16	23.97	18.04	PASS
1.4	26797	6	#0	QAM16	22.77	16.84	PASS
1.4	26915	1	#0	QPSK	24.62	18.69	PASS
1.4	26915	1	#Mid	QPSK	24.78	18.85	PASS
1.4	26915	1	#Max	QPSK	24.63	18.70	PASS
1.4	26915	3	#0	QPSK	24.69	18.76	PASS
1.4	26915	3	#Mid	QPSK	24.73	18.80	PASS
1.4	26915	3	#Max	QPSK	24.72	18.79	PASS
1.4	26915	6	#0	QPSK	23.89	17.96	PASS
1.4	26915	1	#0	QAM16	23.93	18.00	PASS
1.4	26915	1	#Mid	QAM16	23.97	18.04	PASS
1.4	26915	1	#Max	QAM16	23.95	18.02	PASS
1.4	26915	3	#0	QAM16	23.87	17.94	PASS
1.4	26915	3	#Mid	QAM16	23.91	17.98	PASS
1.4	26915	3	#Max	QAM16	23.89	17.96	PASS
1.4	26915	6	#0	QAM16	22.84	16.91	PASS
1.4	27033	1	#0	QPSK	24.22	18.29	PASS
1.4	27033	1	#Mid	QPSK	24.35	18.42	PASS
1.4	27033	1	#Max	QPSK	24.21	18.28	PASS
1.4	27033	3	#0	QPSK	24.28	18.35	PASS
1.4	27033	3	#Mid	QPSK	24.27	18.34	PASS
1.4	27033	3	#Max	QPSK	24.25	18.32	PASS
1.4	27033	6	#0	QPSK	23.47	17.54	PASS
1.4	27033	1	#0	QAM16	23.20	17.27	PASS
1.4	27033	1	#Mid	QAM16	23.36	17.43	PASS
1.4	27033	1	#Max	QAM16	23.15	17.22	PASS
1.4	27033	3	#0	QAM16	23.39	17.46	PASS



1.4	27033	3	#Mid	QAM16	23.51	17.58	PASS
1.4	27033	3	#Max	QAM16	23.42	17.49	PASS
1.4	27033	6	#0	QAM16	22.43	16.50	PASS
3	26805	1	#0	QPSK	24.51	18.58	PASS
3	26805	1	#Mid	QPSK	24.57	18.64	PASS
3	26805	1	#Max	QPSK	24.56	18.63	PASS
3	26805	8	#0	QPSK	23.70	17.77	PASS
3	26805	8	#Mid	QPSK	23.71	17.78	PASS
3	26805	8	#Max	QPSK	23.76	17.83	PASS
3	26805	15	#0	QPSK	23.77	17.84	PASS
3	26805	1	#0	QAM16	23.88	17.95	PASS
3	26805	1	#Mid	QAM16	23.94	18.01	PASS
3	26805	1	#Max	QAM16	23.98	18.05	PASS
3	26805	8	#0	QAM16	22.70	16.77	PASS
3	26805	8	#Mid	QAM16	22.72	16.79	PASS
3	26805	8	#Max	QAM16	22.75	16.82	PASS
3	26805	15	#0	QAM16	22.68	16.75	PASS
3	26915	1	#0	QPSK	24.69	18.76	PASS
3	26915	1	#Mid	QPSK	24.70	18.77	PASS
3	26915	1	#Max	QPSK	24.54	18.61	PASS
3	26915	8	#0	QPSK	23.85	17.92	PASS
3	26915	8	#Mid	QPSK	23.86	17.93	PASS
3	26915	8	#Max	QPSK	23.85	17.92	PASS
3	26915	15	#0	QPSK	23.85	17.92	PASS
3	26915	1	#0	QAM16	23.92	17.99	PASS
3	26915	1	#Mid	QAM16	23.82	17.89	PASS
3	26915	1	#Max	QAM16	23.81	17.88	PASS
3	26915	8	#0	QAM16	22.79	16.86	PASS
3	26915	8	#Mid	QAM16	22.78	16.85	PASS
3	26915	8	#Max	QAM16	22.87	16.94	PASS
3	26915	15	#0	QAM16	22.78	16.85	PASS
3	27025	1	#0	QPSK	24.28	18.35	PASS
3	27025	1	#Mid	QPSK	24.35	18.42	PASS
3	27025	1	#Max	QPSK	24.23	18.30	PASS
3	27025	8	#0	QPSK	23.58	17.65	PASS
3	27025	8	#Mid	QPSK	23.60	17.67	PASS
3	27025	8	#Max	QPSK	23.54	17.61	PASS
3	27025	15	#0	QPSK	23.48	17.55	PASS
3	27025	1	#0	QAM16	23.28	17.35	PASS
3	27025	1	#Mid	QAM16	23.41	17.48	PASS
3	27025	1	#Max	QAM16	23.25	17.32	PASS
3	27025	8	#0	QAM16	22.50	16.57	PASS
3	27025	8	#Mid	QAM16	22.52	16.59	PASS





3	27025	8	#Max	QAM16	22.51	16.58	PASS
3	27025	15	#0	QAM16	22.54	16.61	PASS
5	26815	1	#0	QPSK	24.55	18.62	PASS
5	26815	1	#Mid	QPSK	24.56	18.63	PASS
5	26815	1	#Max	QPSK	24.56	18.63	PASS
5	26815	12	#0	QPSK	23.77	17.84	PASS
5	26815	12	#Mid	QPSK	23.76	17.83	PASS
5	26815	12	#Max	QPSK	23.75	17.82	PASS
5	26815	25	#0	QPSK	23.79	17.86	PASS
5	26815	1	#0	QAM16	24.14	18.21	PASS
5	26815	1	#Mid	QAM16	24.18	18.25	PASS
5	26815	1	#Max	QAM16	24.11	18.18	PASS
5	26815	12	#0	QAM16	22.70	16.77	PASS
5	26815	12	#Mid	QAM16	22.74	16.81	PASS
5	26815	12	#Max	QAM16	22.66	16.73	PASS
5	26815	25	#0	QAM16	22.82	16.89	PASS
5	26915	1	#0	QPSK	24.65	18.72	PASS
5	26915	1	#Mid	QPSK	24.72	18.79	PASS
5	26915	1	#Max	QPSK	24.64	18.71	PASS
5	26915	12	#0	QPSK	23.90	17.97	PASS
5	26915	12	#Mid	QPSK	23.89	17.96	PASS
5	26915	12	#Max	QPSK	23.85	17.92	PASS
5	26915	25	#0	QPSK	23.85	17.92	PASS
5	26915	1	#0	QAM16	23.91	17.98	PASS
5	26915	1	#Mid	QAM16	23.98	18.05	PASS
5	26915	1	#Max	QAM16	23.93	18.00	PASS
5	26915	12	#0	QAM16	22.85	16.92	PASS
5	26915	12	#Mid	QAM16	22.86	16.93	PASS
5	26915	12	#Max	QAM16	22.77	16.84	PASS
5	26915	25	#0	QAM16	22.84	16.91	PASS
5	27015	1	#0	QPSK	24.39	18.46	PASS
5	27015	1	#Mid	QPSK	24.44	18.51	PASS
5	27015	1	#Max	QPSK	24.30	18.37	PASS
5	27015	12	#0	QPSK	23.67	17.74	PASS
5	27015	12	#Mid	QPSK	23.64	17.71	PASS
5	27015	12	#Max	QPSK	23.72	17.79	PASS
5	27015	25	#0	QPSK	23.75	17.82	PASS
5	27015	1	#0	QAM16	23.77	17.84	PASS
5	27015	1	#Mid	QAM16	23.79	17.86	PASS
5	27015	1	#Max	QAM16	23.75	17.82	PASS
5	27015	12	#0	QAM16	22.69	16.76	PASS
5	27015	12	#Mid	QAM16	22.72	16.79	PASS
5	27015	12	#Max	QAM16	22.72	16.79	PASS



5	27015	25	#0	QAM16	22.69	16.76	PASS
10	26840	1	#0	QPSK	24.65	18.72	PASS
10	26840	1	#Mid	QPSK	24.53	18.60	PASS
10	26840	1	#Max	QPSK	24.62	18.69	PASS
10	26840	25	#0	QPSK	23.86	17.93	PASS
10	26840	25	#Mid	QPSK	23.87	17.94	PASS
10	26840	25	#Max	QPSK	23.87	17.94	PASS
10	26840	50	#0	QPSK	23.91	17.98	PASS
10	26840	1	#0	QAM16	24.12	18.19	PASS
10	26840	1	#Mid	QAM16	23.96	18.03	PASS
10	26840	1	#Max	QAM16	24.10	18.17	PASS
10	26840	25	#0	QAM16	22.92	16.99	PASS
10	26840	25	#Mid	QAM16	22.92	16.99	PASS
10	26840	25	#Max	QAM16	22.88	16.95	PASS
10	26840	50	#0	QAM16	22.84	16.91	PASS
10	26915	1	#0	QPSK	24.74	18.81	PASS
10	26915	1	#Mid	QPSK	24.54	18.61	PASS
10	26915	1	#Max	QPSK	24.67	18.74	PASS
10	26915	25	#0	QPSK	23.79	17.86	PASS
10	26915	25	#Mid	QPSK	23.79	17.86	PASS
10	26915	25	#Max	QPSK	23.86	17.93	PASS
10	26915	50	#0	QPSK	23.82	17.89	PASS
10	26915	1	#0	QAM16	23.92	17.99	PASS
10	26915	1	#Mid	QAM16	23.77	17.84	PASS
10	26915	1	#Max	QAM16	23.89	17.96	PASS
10	26915	25	#0	QAM16	22.76	16.83	PASS
10	26915	25	#Mid	QAM16	22.77	16.84	PASS
10	26915	25	#Max	QAM16	22.82	16.89	PASS
10	26915	50	#0	QAM16	22.80	16.87	PASS
10	26990	1	#0	QPSK	24.46	18.53	PASS
10	26990	1	#Mid	QPSK	24.26	18.33	PASS
10	26990	1	#Max	QPSK	24.43	18.50	PASS
10	26990	25	#0	QPSK	23.65	17.72	PASS
10	26990	25	#Mid	QPSK	23.66	17.73	PASS
10	26990	25	#Max	QPSK	23.65	17.72	PASS
10	26990	50	#0	QPSK	23.64	17.71	PASS
10	26990	1	#0	QAM16	23.42	17.49	PASS
10	26990	1	#Mid	QAM16	23.32	17.39	PASS
10	26990	1	#Max	QAM16	23.44	17.51	PASS
10	26990	25	#0	QAM16	22.66	16.73	PASS
10	26990	25	#Mid	QAM16	22.67	16.74	PASS
10	26990	25	#Max	QAM16	22.62	16.69	PASS
10	26990	50	#0	QAM16	22.59	16.66	PASS



15	26865	1	#0	QPSK	24.55	18.62	PASS
15	26865	1	#Mid	QPSK	24.48	18.55	PASS
15	26865	1	#Max	QPSK	24.39	18.46	PASS
15	26865	36	#0	QPSK	23.87	17.94	PASS
15	26865	36	#Mid	QPSK	23.89	17.96	PASS
15	26865	36	#Max	QPSK	23.69	17.76	PASS
15	26865	75	#0	QPSK	23.77	17.84	PASS
15	26865	1	#0	QAM16	24.01	18.08	PASS
15	26865	1	#Mid	QAM16	23.98	18.05	PASS
15	26865	1	#Max	QAM16	23.85	17.92	PASS
15	26865	36	#0	QAM16	22.89	16.96	PASS
15	26865	36	#Mid	QAM16	22.90	16.97	PASS
15	26865	36	#Max	QAM16	22.72	16.79	PASS
15	26865	75	#0	QAM16	22.80	16.87	PASS
15	26915	1	#0	QPSK	24.54	18.61	PASS
15	26915	1	#Mid	QPSK	24.54	18.61	PASS
15	26915	1	#Max	QPSK	24.36	18.43	PASS
15	26915	36	#0	QPSK	23.82	17.89	PASS
15	26915	36	#Mid	QPSK	23.83	17.90	PASS
15	26915	36	#Max	QPSK	23.69	17.76	PASS
15	26915	75	#0	QPSK	23.85	17.92	PASS
15	26915	1	#0	QAM16	23.74	17.81	PASS
15	26915	1	#Mid	QAM16	23.77	17.84	PASS
15	26915	1	#Max	QAM16	23.61	17.68	PASS
15	26915	36	#0	QAM16	22.78	16.85	PASS
15	26915	36	#Mid	QAM16	22.78	16.85	PASS
15	26915	36	#Max	QAM16	22.70	16.77	PASS
15	26915	75	#0	QAM16	22.78	16.85	PASS
15	26965	1	#0	QPSK	24.56	18.63	PASS
15	26965	1	#Mid	QPSK	24.38	18.45	PASS
15	26965	1	#Max	QPSK	24.32	18.39	PASS
15	26965	36	#0	QPSK	23.76	17.83	PASS
15	26965	36	#Mid	QPSK	23.77	17.84	PASS
15	26965	36	#Max	QPSK	23.76	17.83	PASS
15	26965	75	#0	QPSK	23.73	17.80	PASS
15	26965	1	#0	QAM16	23.61	17.68	PASS
15	26965	1	#Mid	QAM16	23.48	17.55	PASS
15	26965	1	#Max	QAM16	23.40	17.47	PASS
15	26965	36	#0	QAM16	22.74	16.81	PASS
15	26965	36	#Mid	QAM16	22.70	16.77	PASS
15	26965	36	#Max	QAM16	22.71	16.78	PASS
15	26965	75	#0	QAM16	22.72	16.79	PASS

## 5.2. Occupied Bandwidth

### Ambient condition

Temperature	Relative humidity	Pressure
23°C ~25°C	45%~50%	101.5kPa

### Method of Measurement

The EUT was connected to Spectrum Analyzer and Base Station Simulator via power Splitter. The occupied bandwidth is measured using spectrum analyzer.

RBW is set to  $\geq 1\%$ EBW, VBW is set to 3x RBW.

99% power and -26dBc occupied bandwidths are recorded. Spectrum analyzer plots are included on the following pages.

### Test Setup

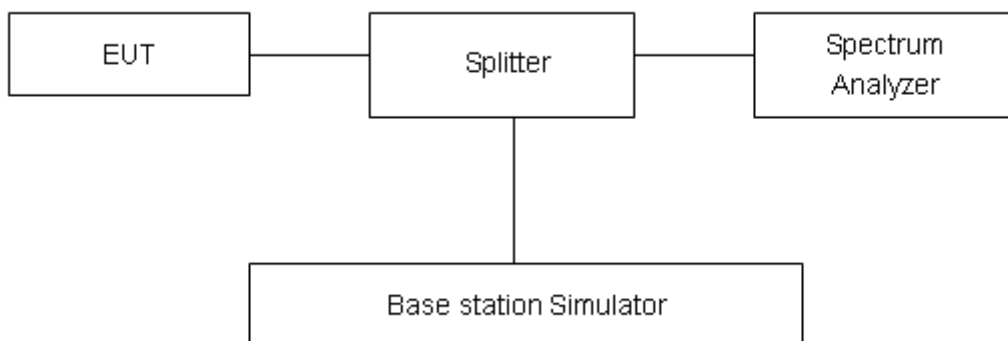

### Limits

No specific occupied bandwidth requirements in part 2.1049.

### Measurement Uncertainty

The assessed measurement uncertainty to ensure 95% confidence level for the normal distribution is with the coverage factor  $k = 2$ ,  $U = 624\text{Hz}$ .

**Test Result**

Mode	Channel	Frequency (MHz)	99% Power Bandwidth (MHz)	-26dBc Bandwidth(MHz)
<b>GSM 850 (GMSK)</b>	128	824.2	0.245	0.311
	190	836.6	0.252	0.319
	251	848.8	0.242	0.311
<b>GPRS 850 (GMSK)</b>	128	824.2	0.246	0.312
	190	836.6	0.246	0.309
	251	848.8	0.243	0.309
<b>EGPRS 850 (8PSK)</b>	128	824.2	0.247	0.303
	190	836.6	0.243	0.308
	251	848.8	0.248	0.312
<b>WCDMA Band V (RMC)</b>	4132	826.4	4.123	4.685
	4183	836.6	4.113	4.667
	4233	846.6	4.126	4.689

<b>LTE Band 5</b>						
RB	Modulation	Bandwidth (MHz)	Channel	Frequency (MHz)	99% Power Bandwidth(MHz)	-26dBc Bandwidth(MHz)
1	QPSK	1.4	20407	824.7	0.264	0.397
			20525	836.5	0.266	0.404
			20643	848.3	0.267	0.406
		3	20415	825.5	0.340	0.472
			20525	836.5	0.333	0.488
			20635	847.5	0.334	0.485
		5	20425	826.5	0.467	0.649
			20525	836.5	0.480	0.681
			20625	846.5	0.459	0.659
	10	20450	829	0.688	1.006	
		20525	836.5	0.675	0.967	
		20600	844	0.717	0.941	
	16QAM	1.4	20407	824.7	0.264	0.391
20525			836.5	0.271	0.401	



		3	20643	848.3	0.263	0.392		
			20415	825.5	0.325	0.465		
			20525	836.5	0.333	0.477		
		5	20635	847.5	0.325	0.452		
			20425	826.5	0.435	0.604		
			20525	836.5	0.457	0.654		
		10	20625	846.5	0.450	0.655		
			20450	829	0.671	0.892		
			20525	836.5	0.663	0.914		
		100%	QPSK	1.4	20600	844	0.700	0.940
					20407	824.7	1.097	1.280
					20525	836.5	1.093	1.269
3	20643			848.3	1.100	1.296		
	20415			825.5	2.699	2.966		
	20525			836.5	2.707	2.979		
5	20635			847.5	2.703	2.996		
	20425			826.5	4.510	4.986		
	20525			836.5	4.506	4.970		
10	20625			846.5	4.508	4.981		
	20450			829	8.974	9.887		
	20525			836.5	8.991	9.823		
16QAM	1.4	20600	844	8.968	9.809			
		20407	824.7	1.103	1.293			
		20525	836.5	1.102	1.309			
	3	20643	848.3	1.092	1.276			
		20415	825.5	2.694	2.958			
		20525	836.5	2.696	2.973			
	5	20635	847.5	2.689	2.974			
		20425	826.5	4.519	4.963			
		20525	836.5	4.523	4.950			
	10	20625	846.5	4.509	4.996			
		20450	829	8.990	9.741			
		20525	836.5	8.957	9.763			
			20600	844	8.950	9.775		



LTE Band 26						
RB	Modulation	Bandwidth (MHz)	Channel	Frequency (MHz)	99% Power Bandwidth(MHz)	-26dBc Bandwidth(MHz)
1	QPSK	1.4	26797	824.7	0.264	0.396
			26915	836.5	0.267	0.407
			27033	848.3	0.269	0.413
		3	26805	825.5	0.345	0.466
			26915	836.5	0.339	0.480
			27025	847.5	0.330	0.473
		5	26815	826.5	0.482	0.673
			26915	836.5	0.477	0.706
			27015	846.5	0.480	0.674
		10	26840	829	0.704	0.984
			26915	836.5	0.709	0.981
			26990	844	0.713	0.983
		15	26865	831.5	1.026	1.492
			26915	836.5	1.030	1.493
			26965	841.5	1.034	1.522
	16QAM	1.4	26797	824.7	0.260	0.380
			26915	836.5	0.267	0.396
			27033	848.3	0.264	0.393
		3	26805	825.5	0.323	0.464
			26915	836.5	0.329	0.474
			27025	847.5	0.325	0.451
		5	26815	826.5	0.459	0.655
			26915	836.5	0.488	0.679
			27015	846.5	0.436	0.635
		10	26840	829	0.674	0.964
			26915	836.5	0.660	0.921
			26990	844	0.657	0.943
15		26865	831.5	1.037	1.494	
		26915	836.5	1.005	1.331	
		26965	841.5	0.983	1.478	
100%	QPSK	1.4	26797	824.7	1.092	1.278



			26915	836.5	1.098	1.298
			27033	848.3	1.098	1.283
		3	26805	825.5	2.696	2.949
			26915	836.5	2.702	2.996
			27025	847.5	2.714	2.984
		5	26815	826.5	4.532	4.991
			26915	836.5	4.515	5.015
			27015	846.5	4.501	4.917
		10	26840	829	8.981	9.800
			26915	836.5	8.996	9.666
			26990	844	8.941	9.873
		15	26865	831.5	13.497	14.790
			26915	836.5	13.463	14.711
			26965	841.5	13.425	14.651
		16QAM	1.4	26797	824.7	1.103
	26915			836.5	1.091	1.272
	27033			848.3	1.097	1.298
	3		26805	825.5	2.695	2.970
			26915	836.5	2.699	2.959
			27025	847.5	2.690	2.962
	5		26815	826.5	4.504	4.979
			26915	836.5	4.520	4.945
			27015	846.5	4.516	5.015
	10		26840	829	8.991	9.844
			26915	836.5	8.970	9.699
			26990	844	8.980	9.798
	15	26865	831.5	13.443	14.580	
26915		836.5	13.448	14.651		
26965		841.5	13.459	14.447		



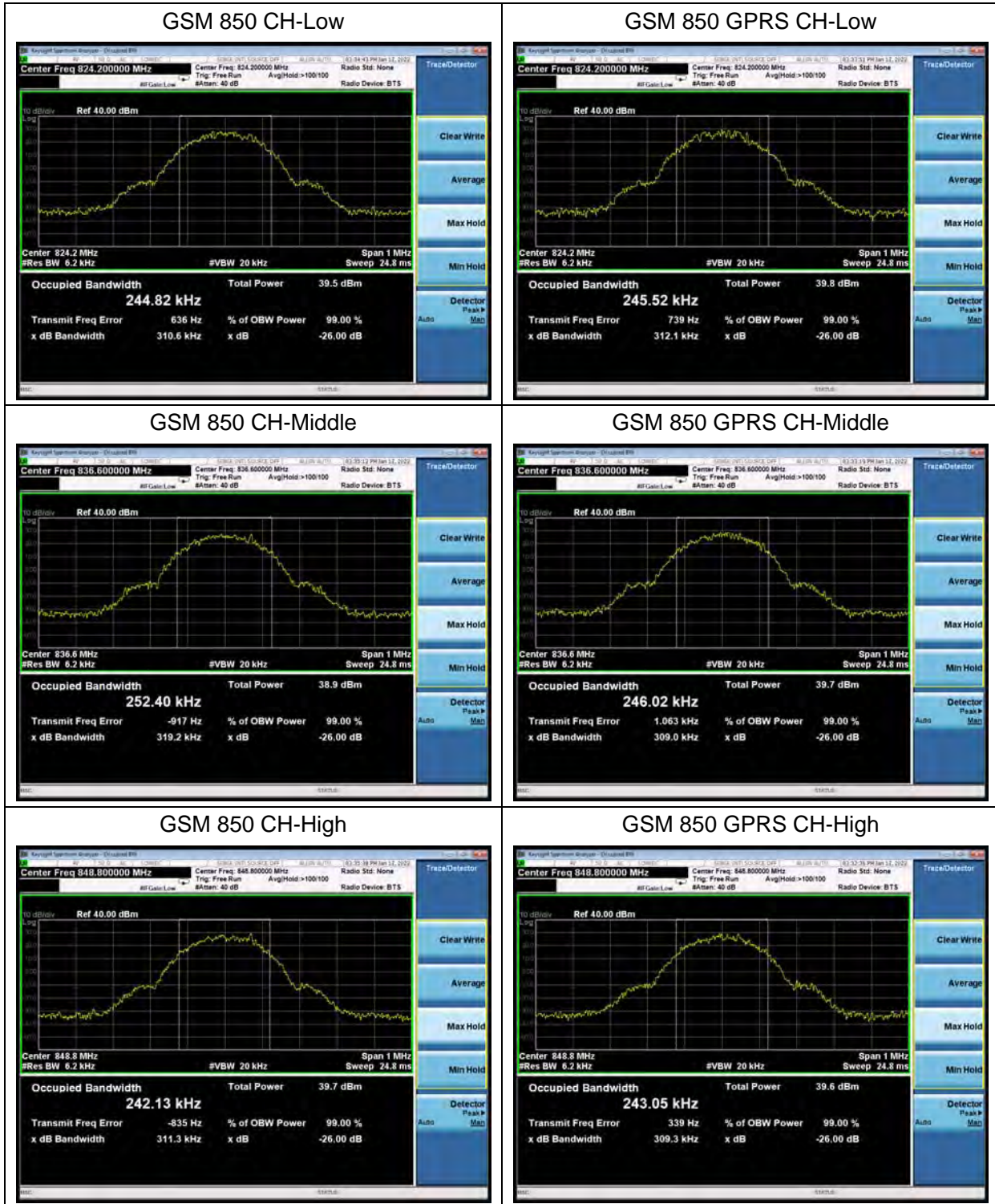

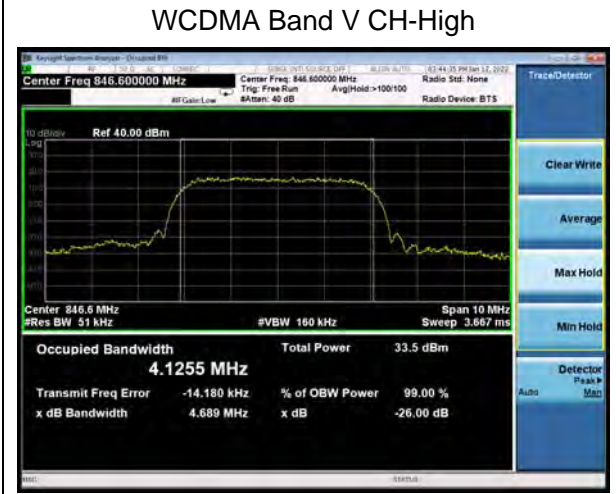
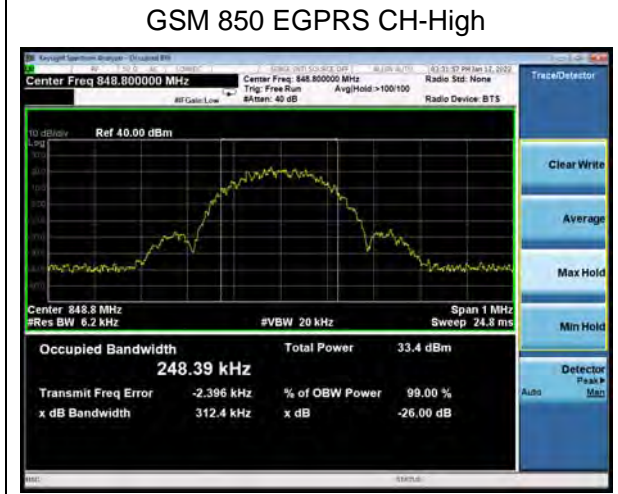
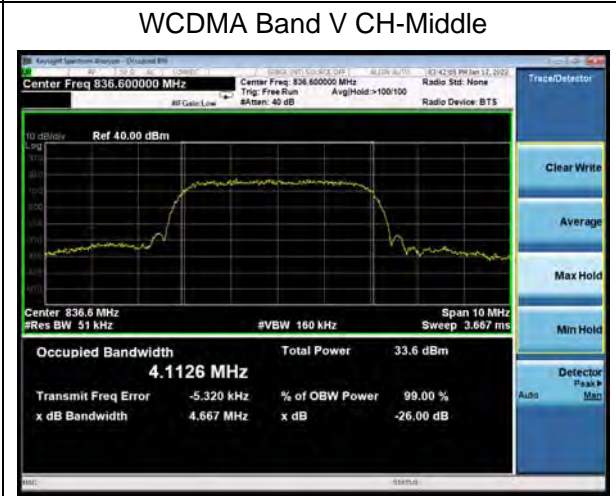
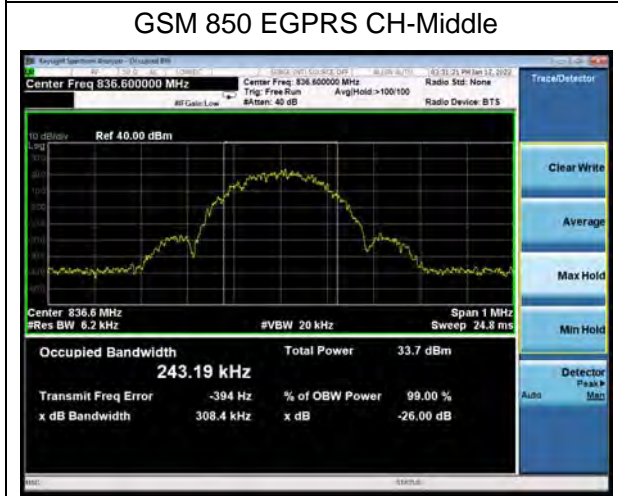
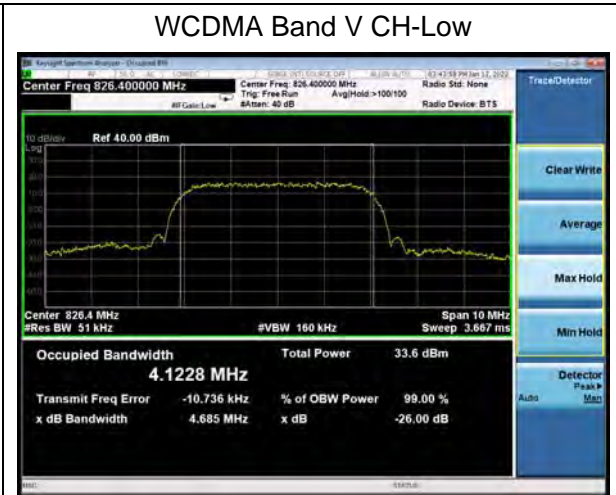
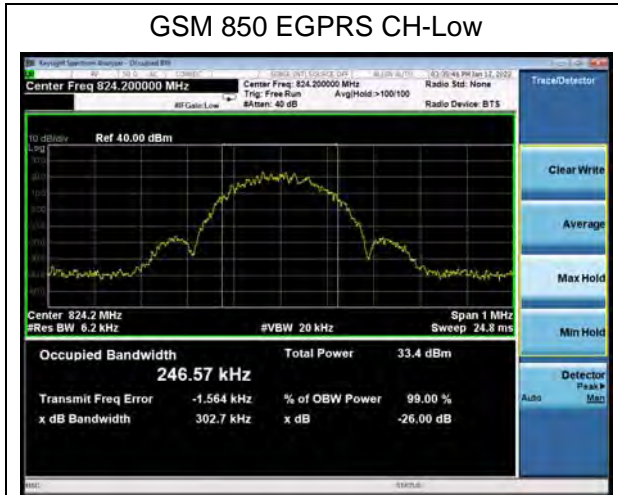



1 RB

LTE Band 5 QPSK 1.4MHz CH-Low

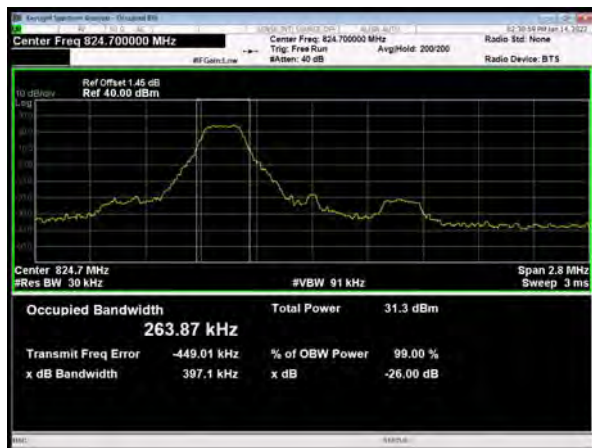

LTE Band 5 QPSK 3MHz CH-Low

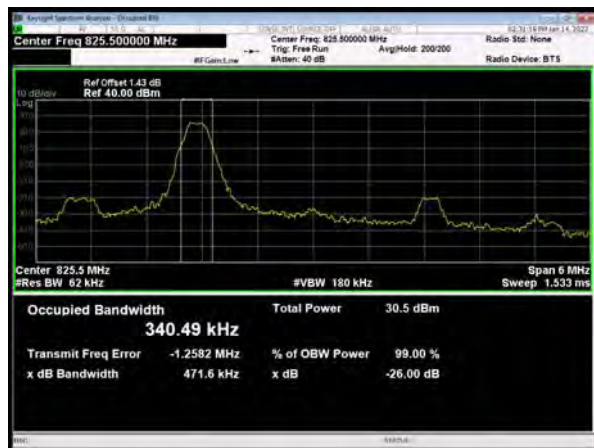

LTE Band 5 QPSK 1.4MHz CH-Middle



LTE Band 5 QPSK 3MHz CH-Middle

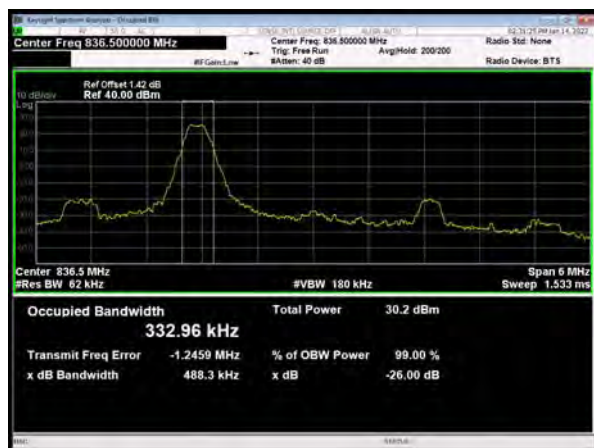

LTE Band 5 QPSK 1.4MHz CH-High

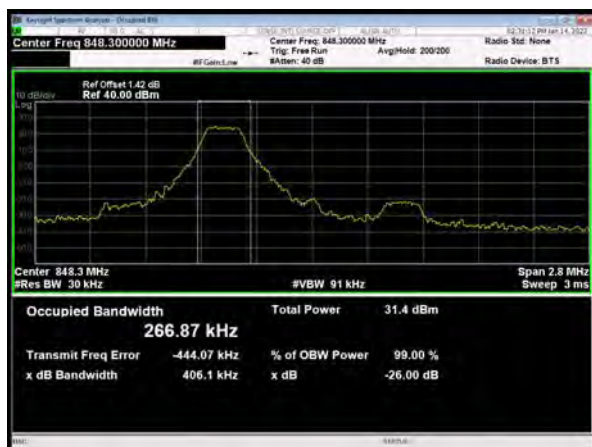

LTE Band 5 QPSK 3MHz CH-High

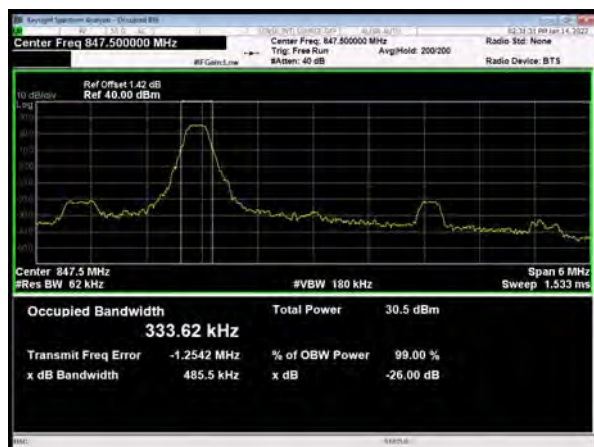

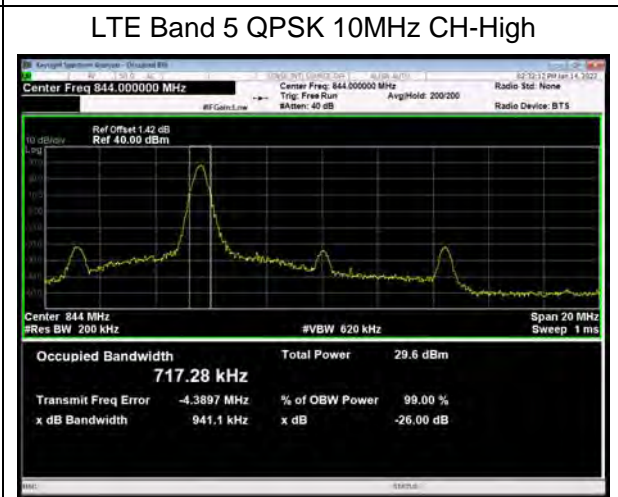
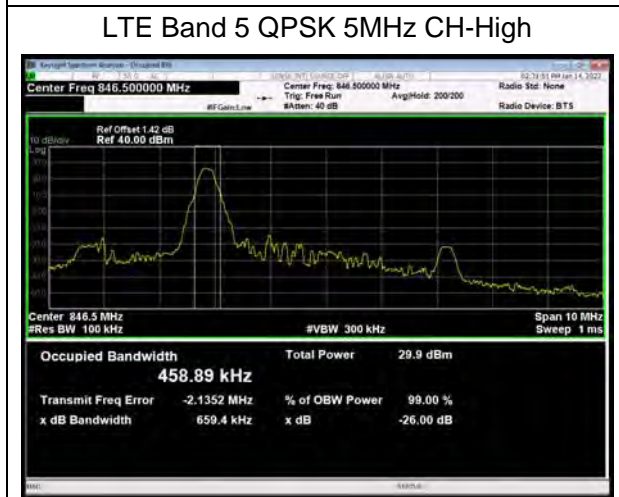
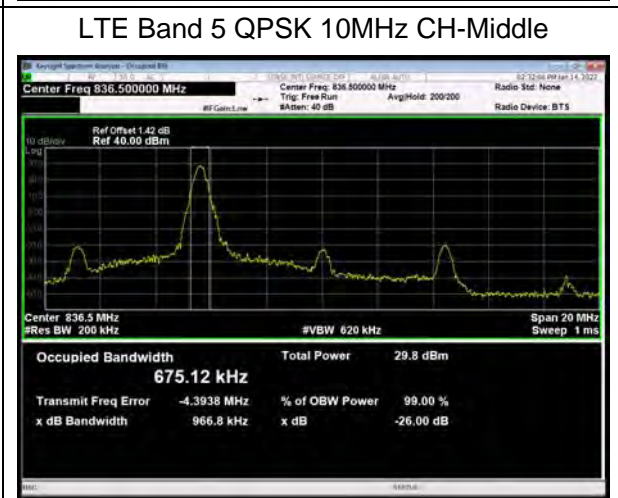
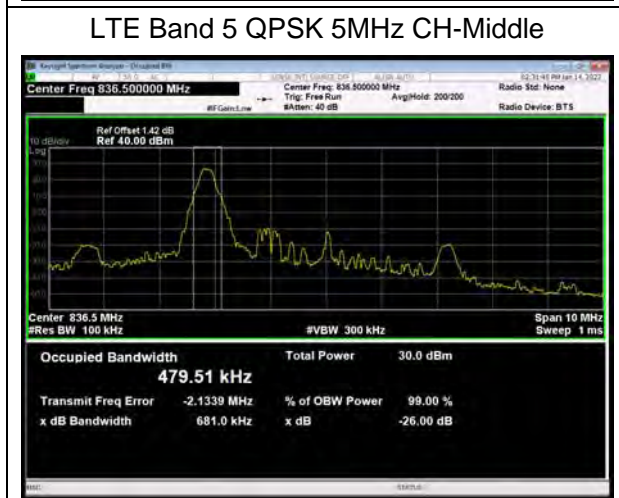
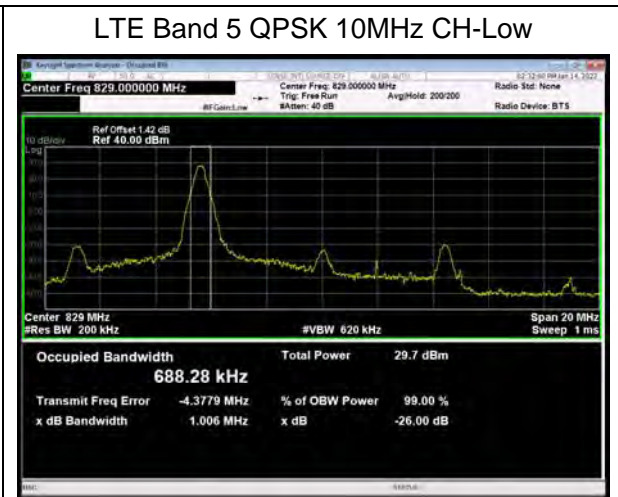
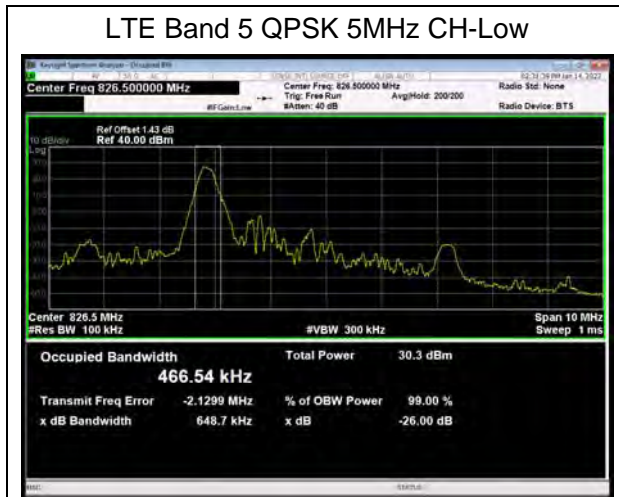

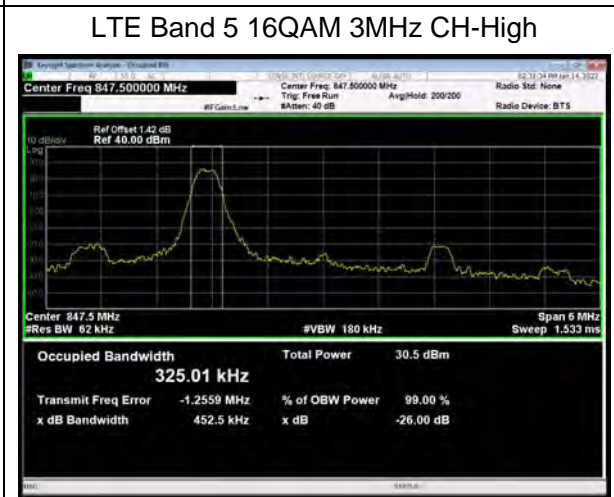
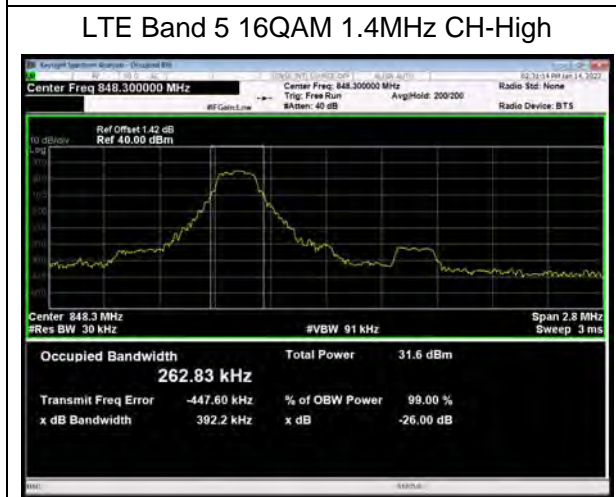
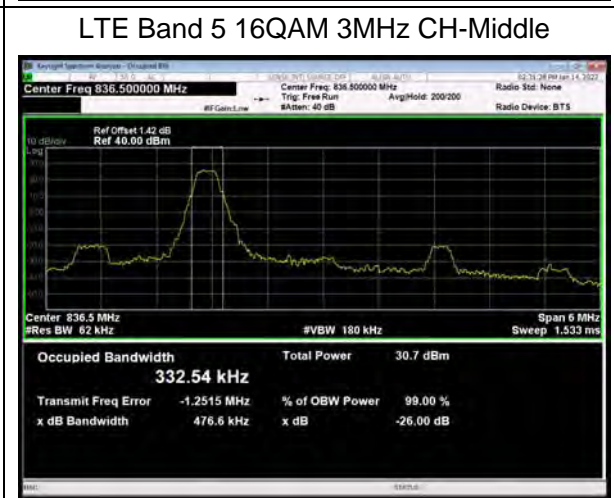
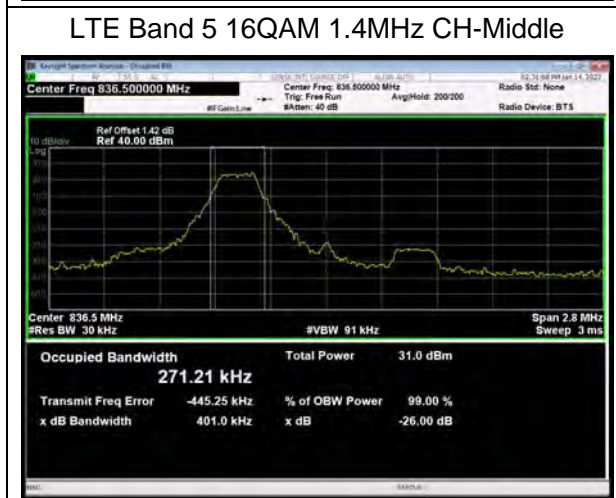
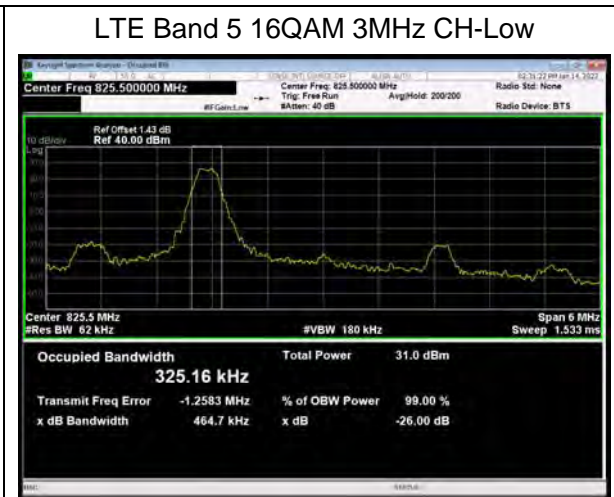
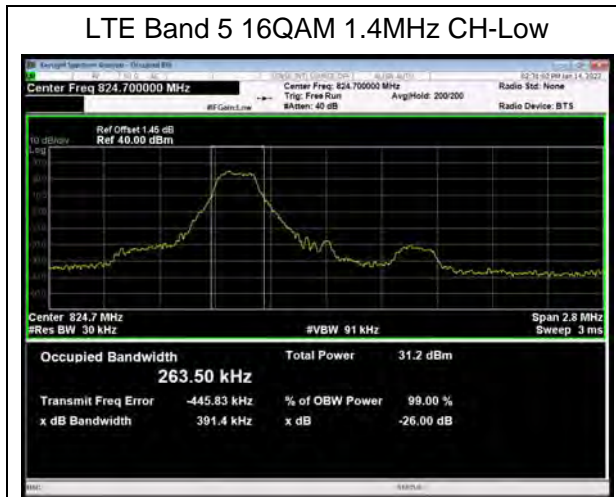

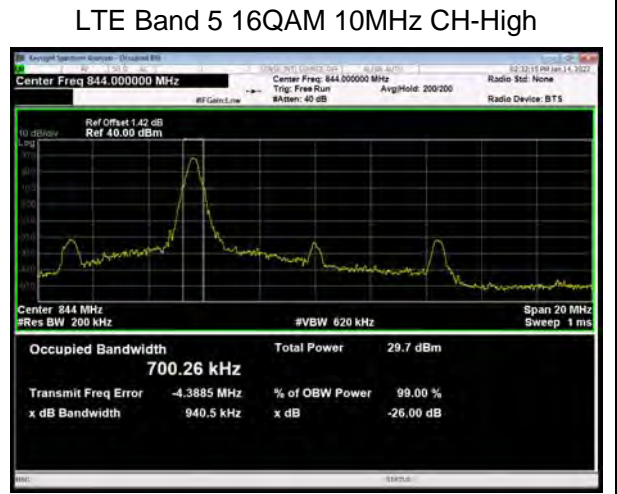
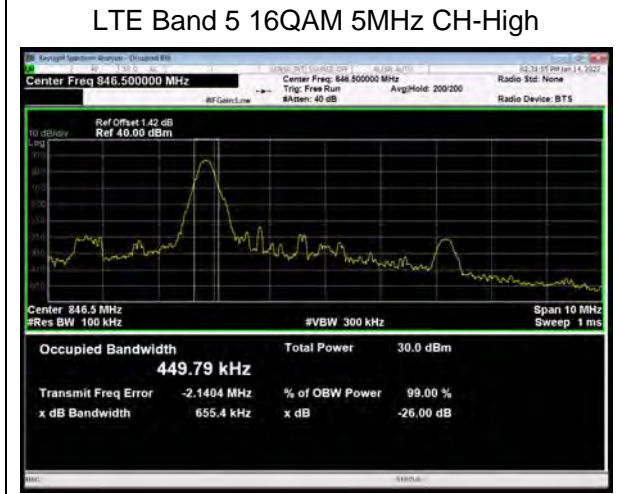
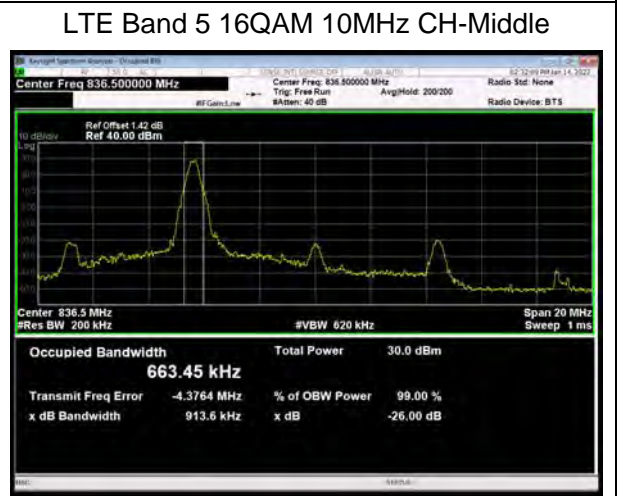
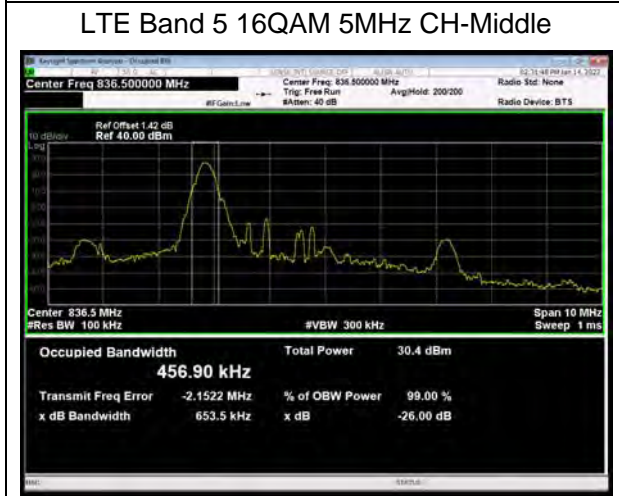
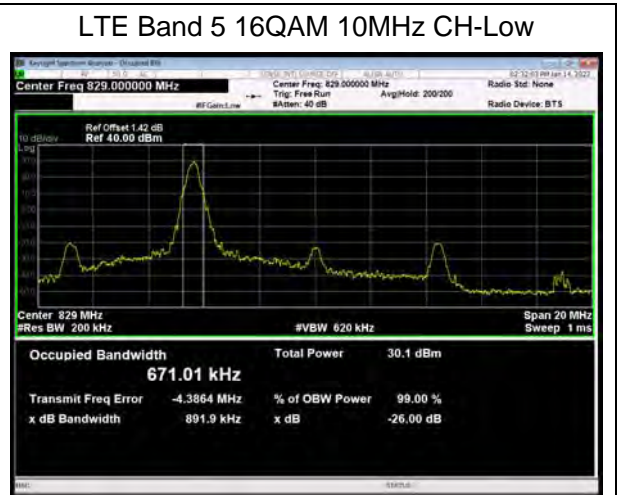
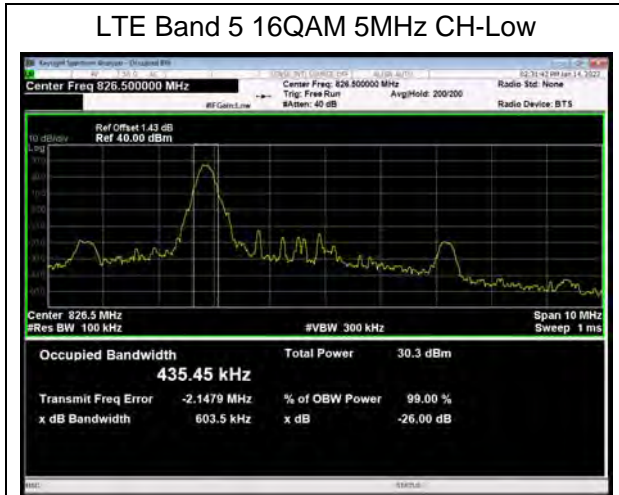

100% RB

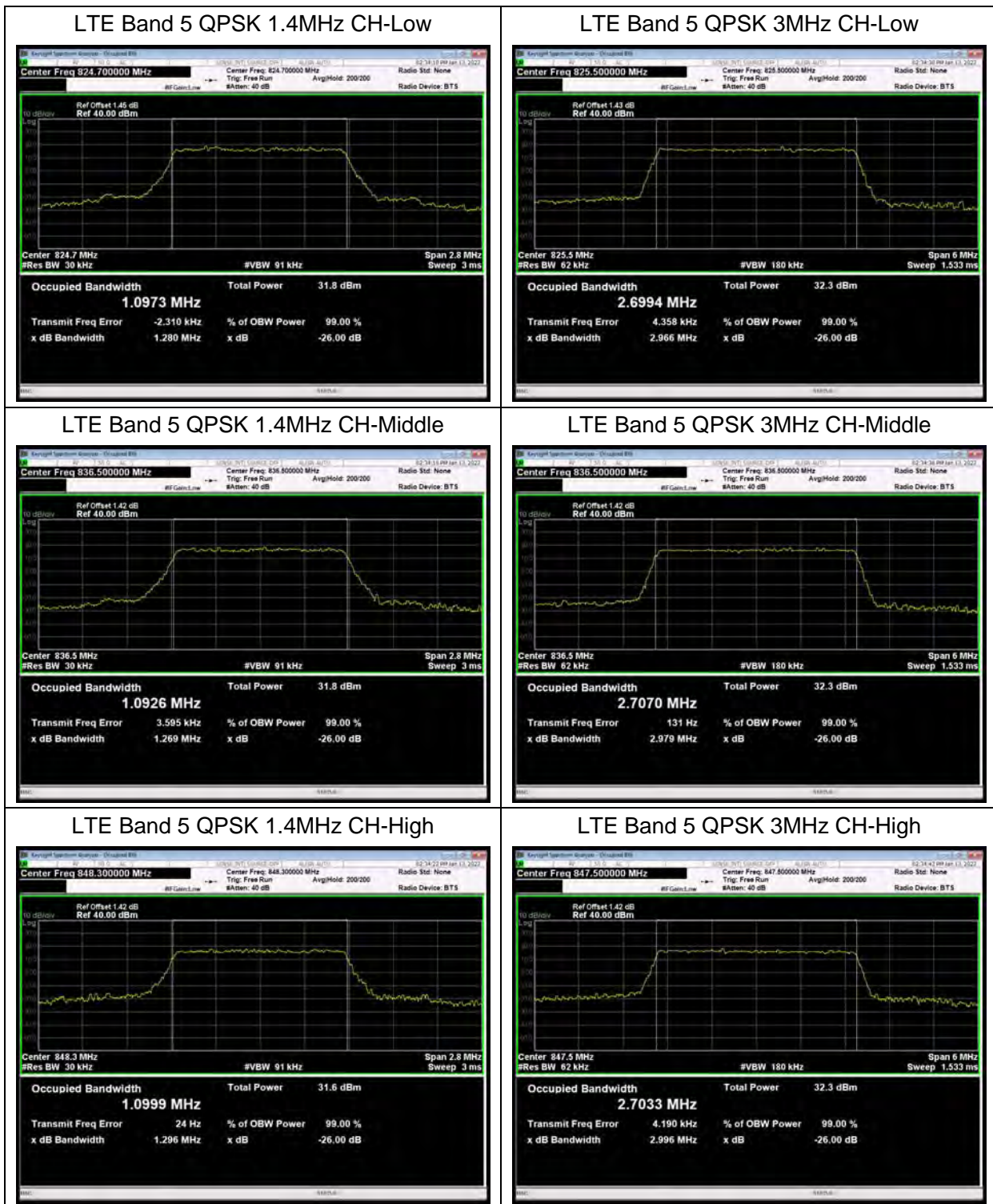

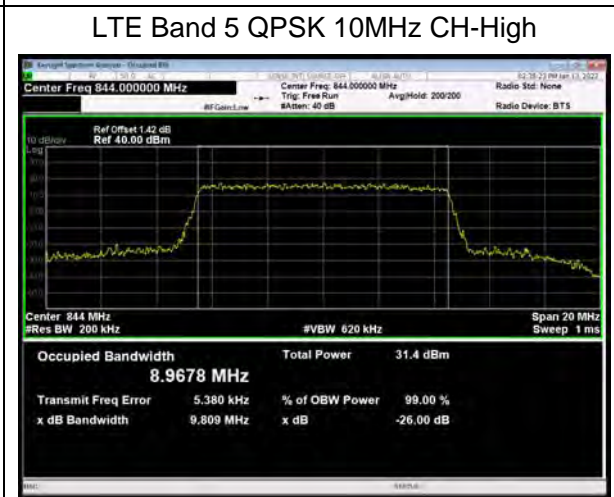
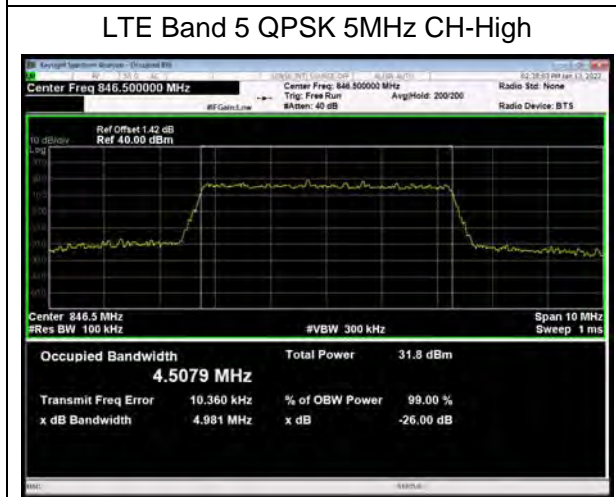
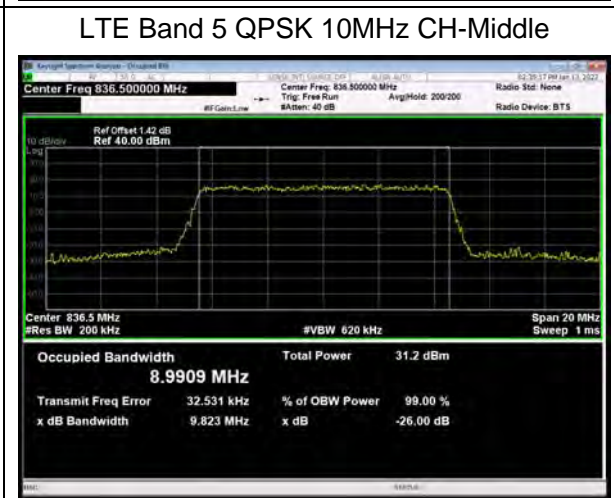
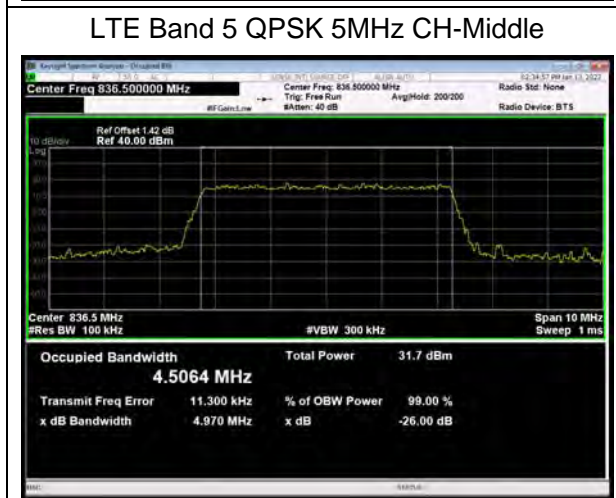
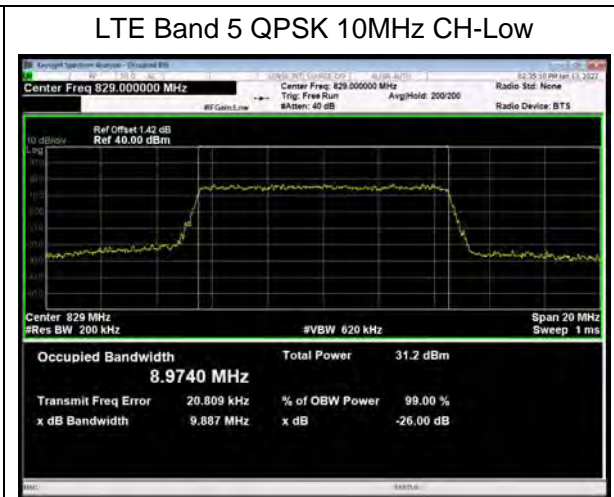
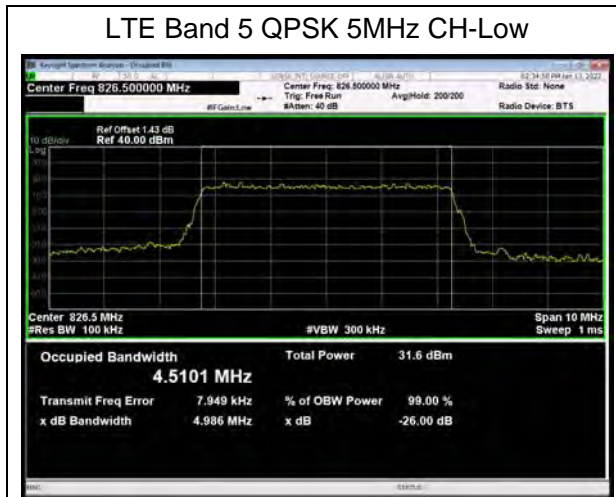



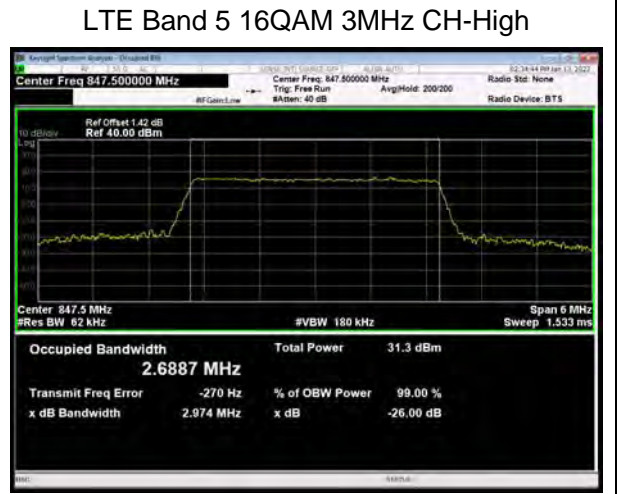
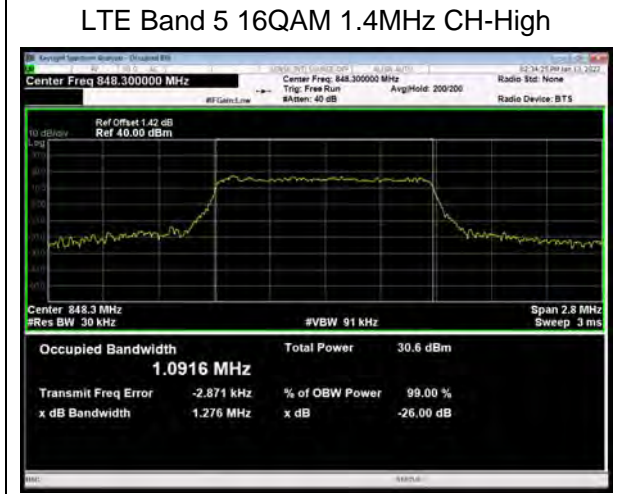
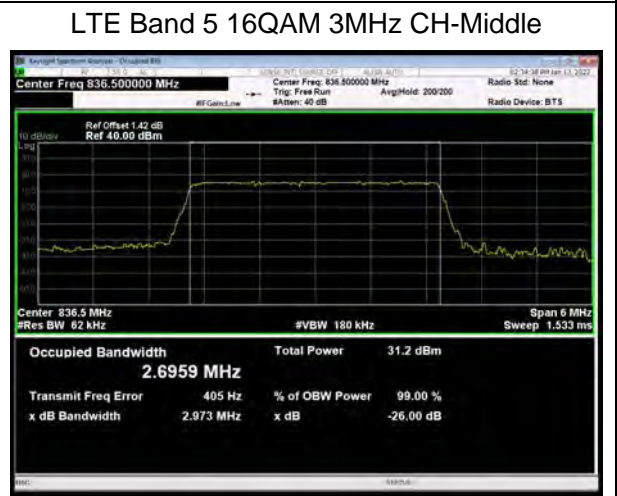
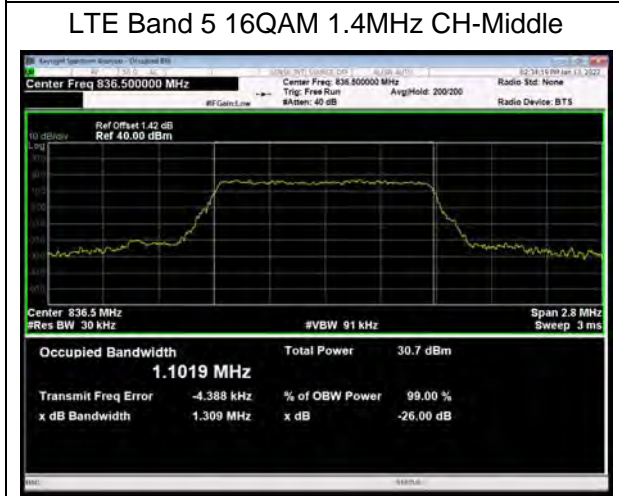
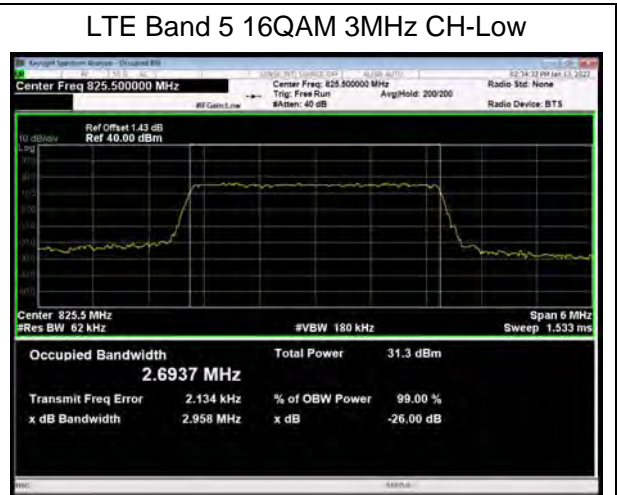
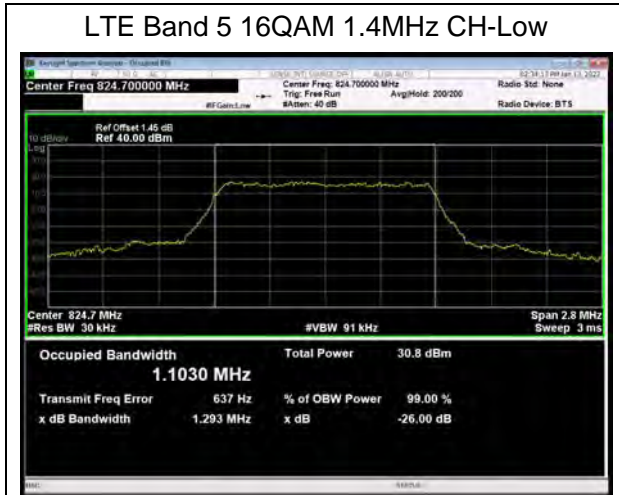

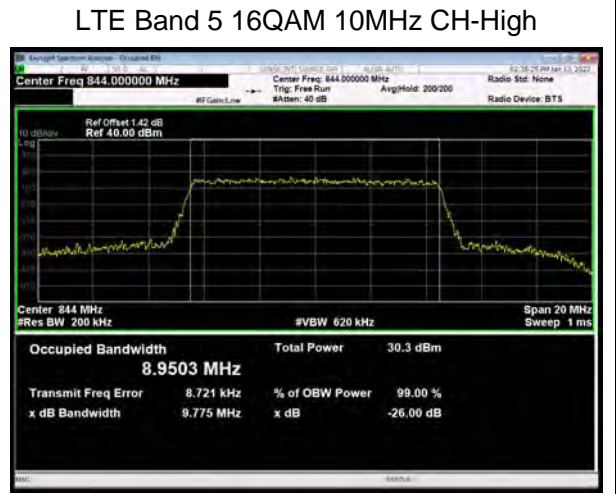
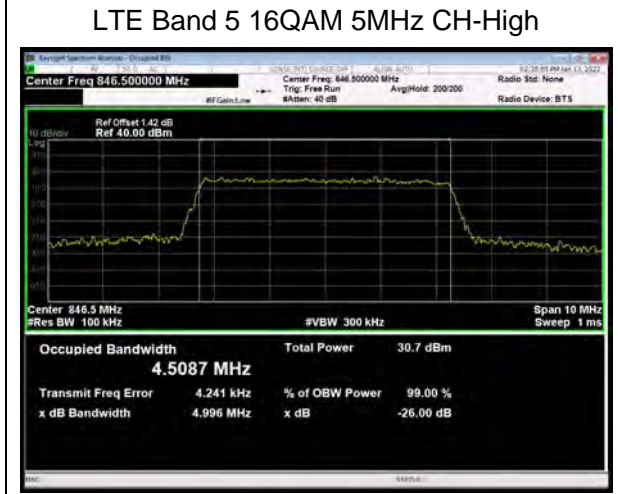
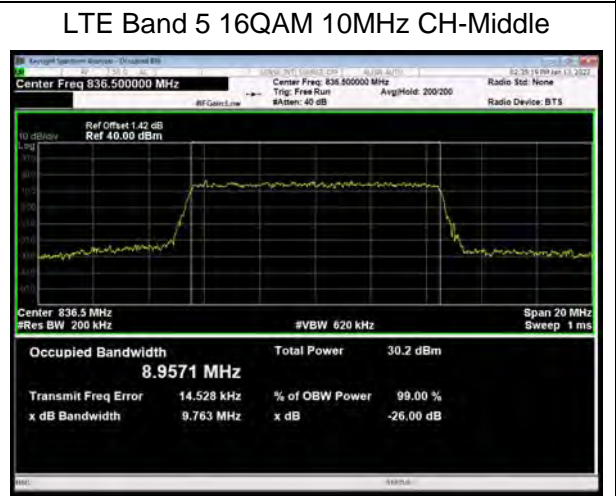
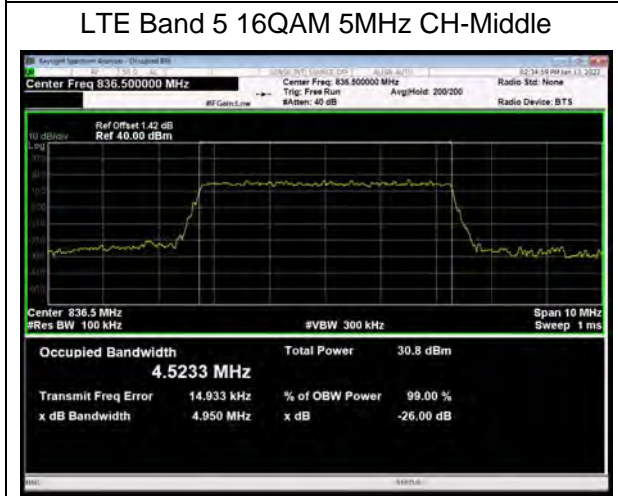
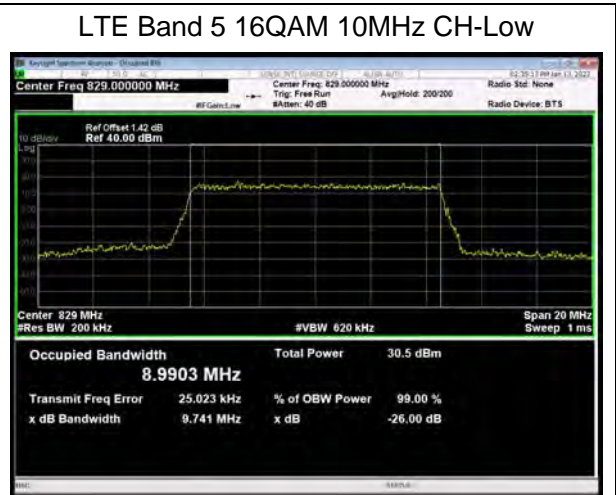
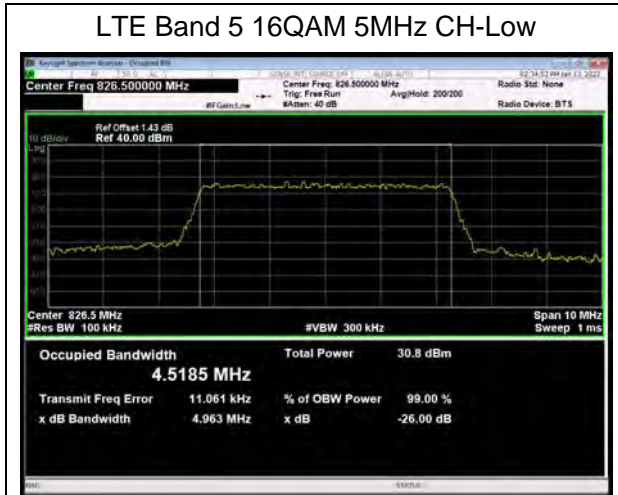



1 RB

LTE Band 26 QPSK 1.4MHz CH-Low

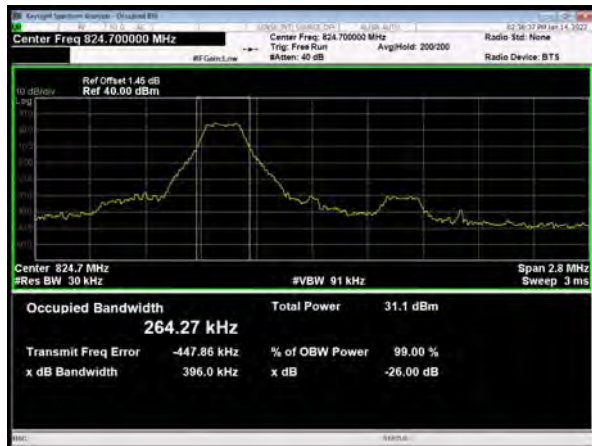

LTE Band 26 QPSK 3MHz CH-Low

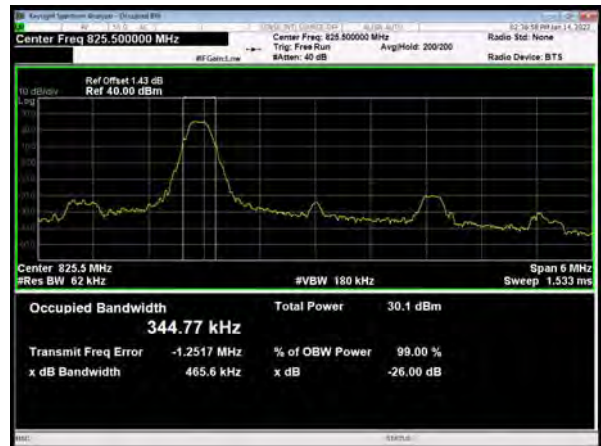

LTE Band 26 QPSK 1.4MHz CH-Middle

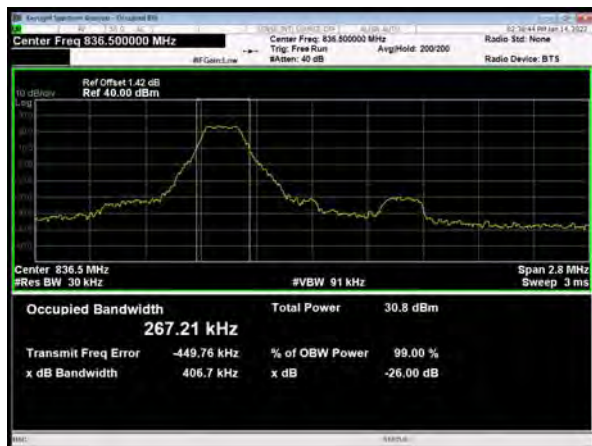

LTE Band 26 QPSK 3MHz CH-Middle

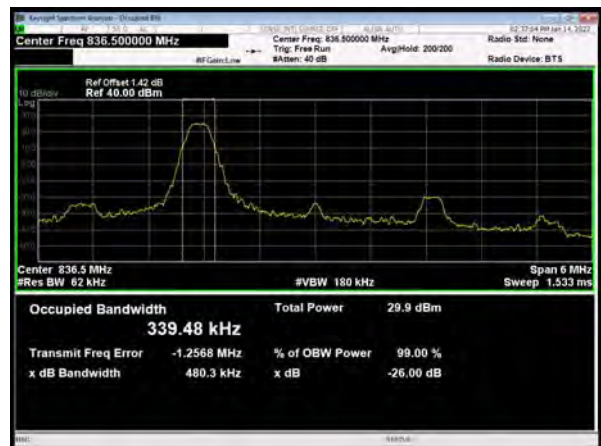

LTE Band 26 QPSK 1.4MHz CH-High

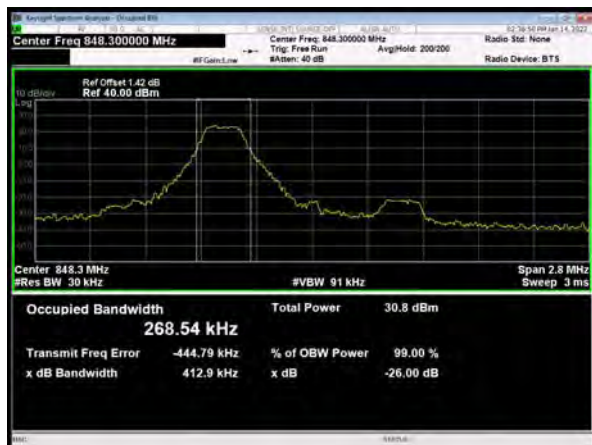

LTE Band 26 QPSK 3MHz CH-High

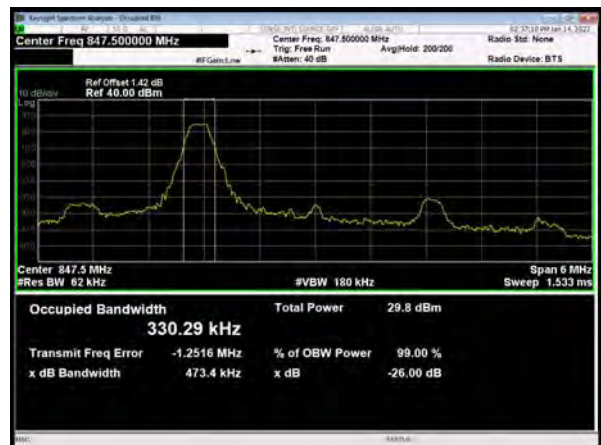

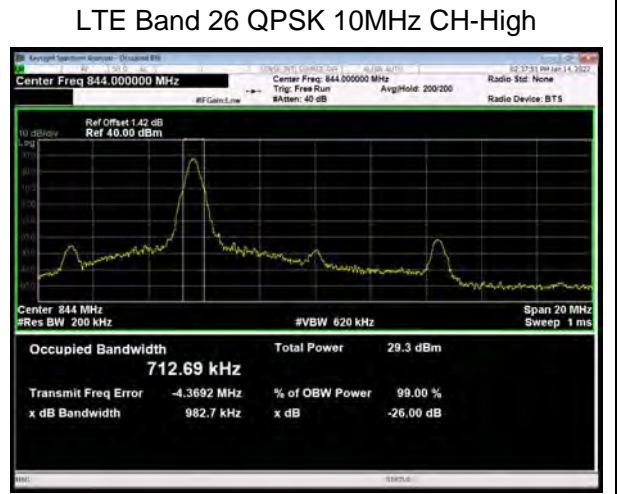
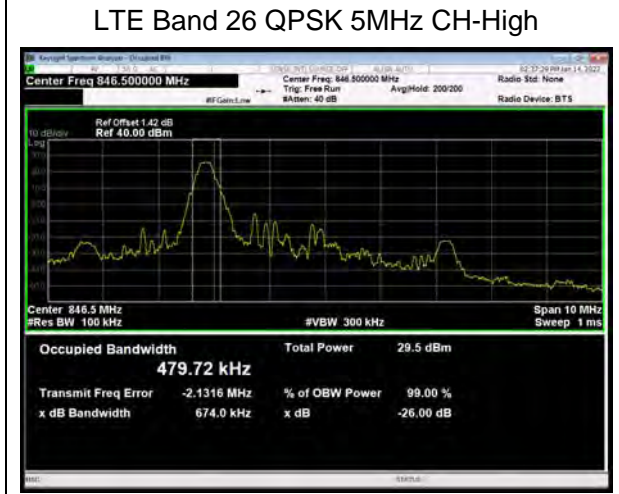
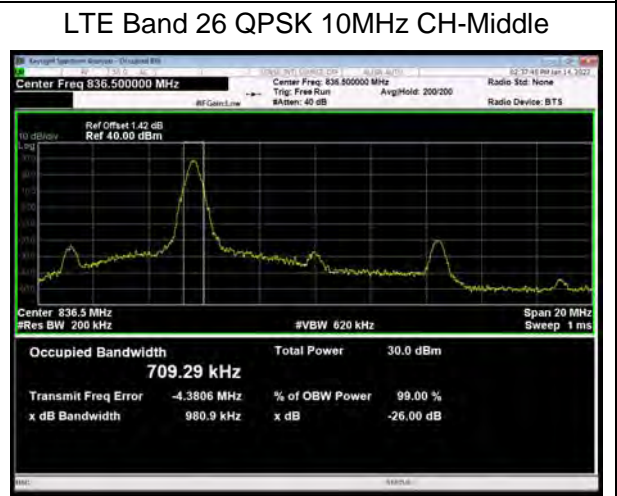
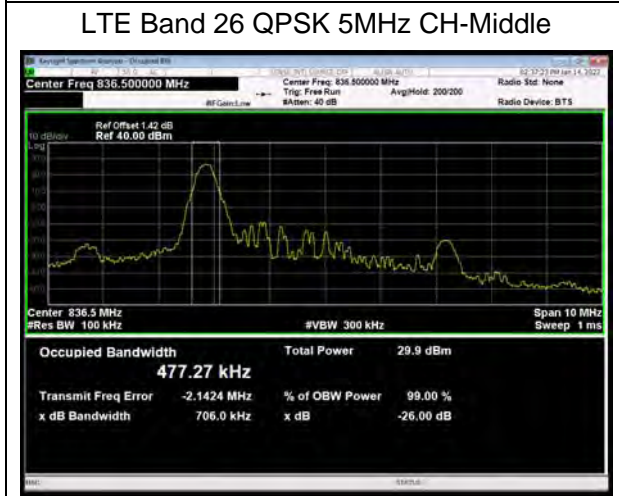
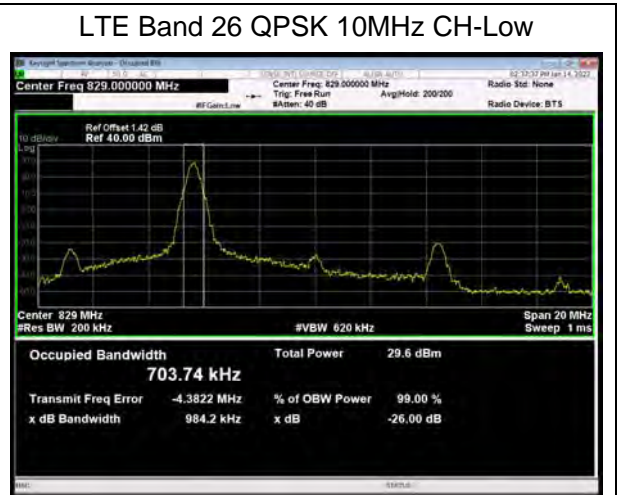
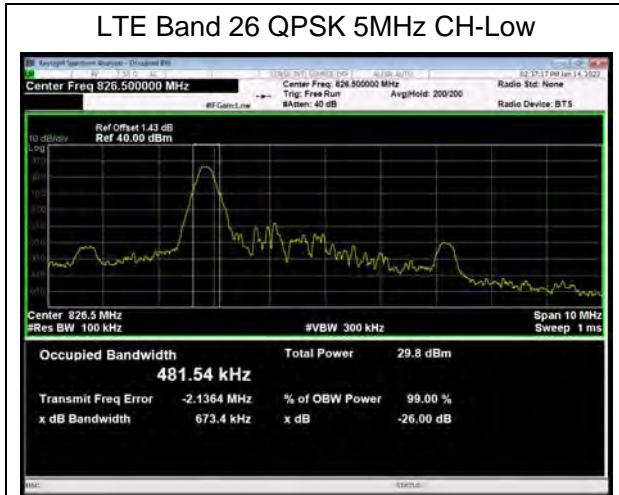



### LTE Band 26 QPSK 15MHz CH-Low

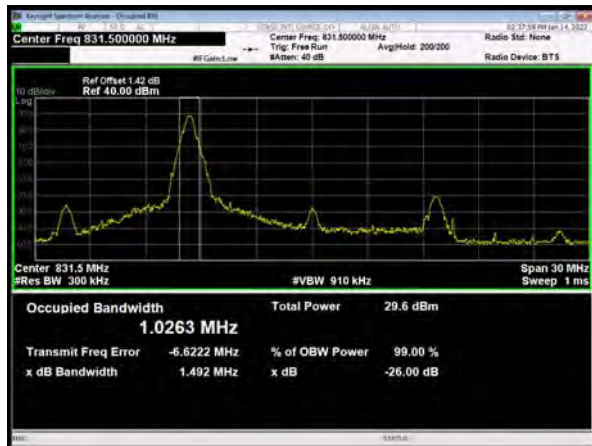

### LTE Band 26 16QAM 1.4MHz CH-Low

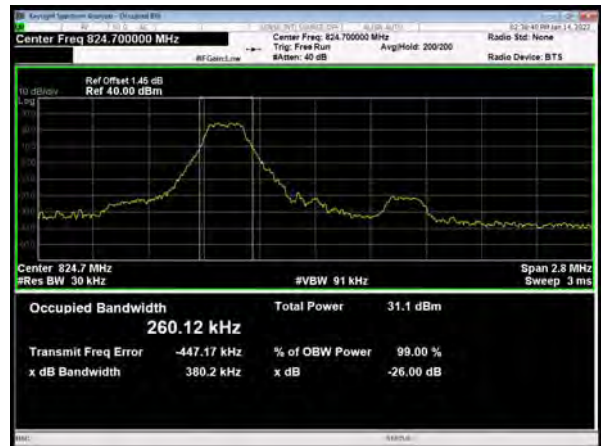

### LTE Band 26 QPSK 15MHz CH-Middle

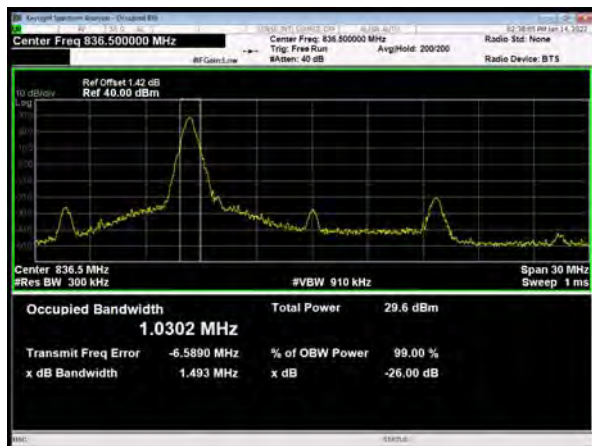

### LTE Band 26 16QAM 1.4MHz CH-Middle

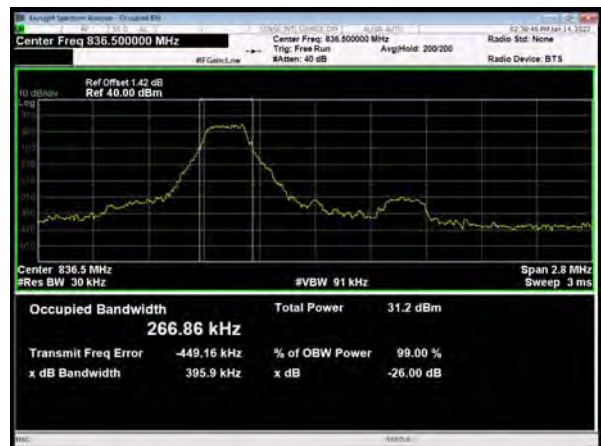

### LTE Band 26 QPSK 15MHz CH-High

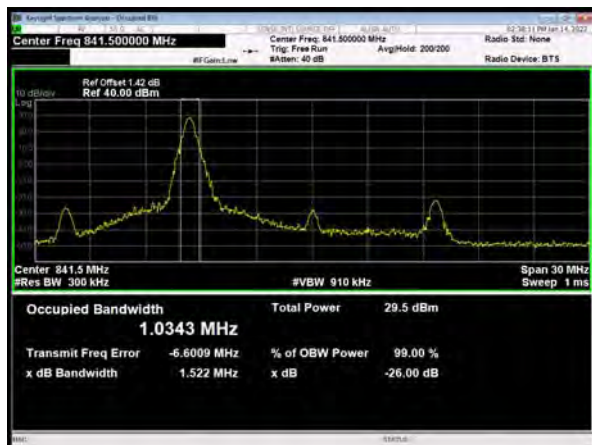

### LTE Band 26 16QAM 1.4MHz CH-High

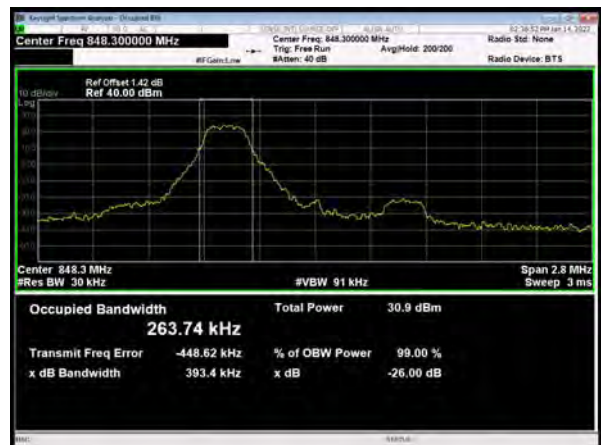



### LTE Band 26 16QAM 3MHz CH-Low

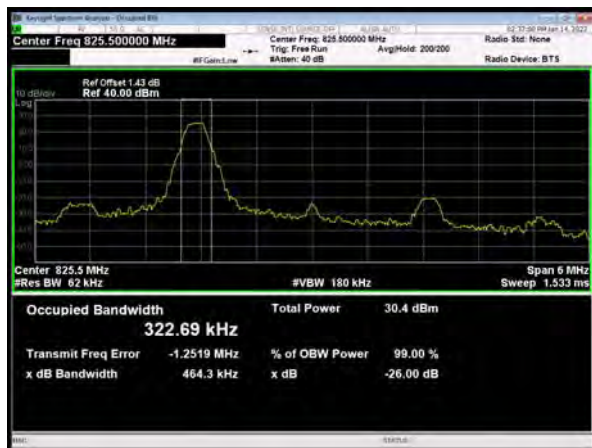

### LTE Band 26 16QAM 5MHz CH-Low

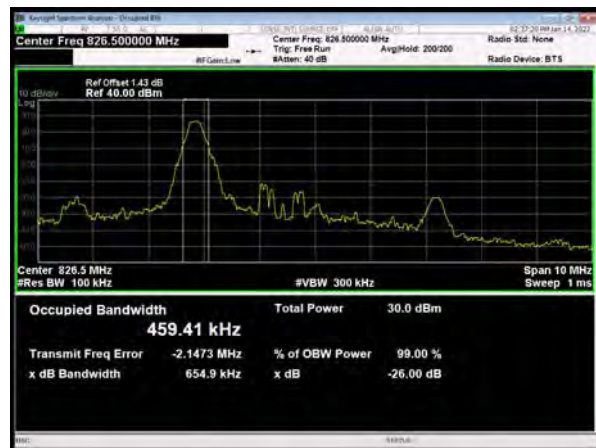

### LTE Band 26 16QAM 3MHz CH-Middle

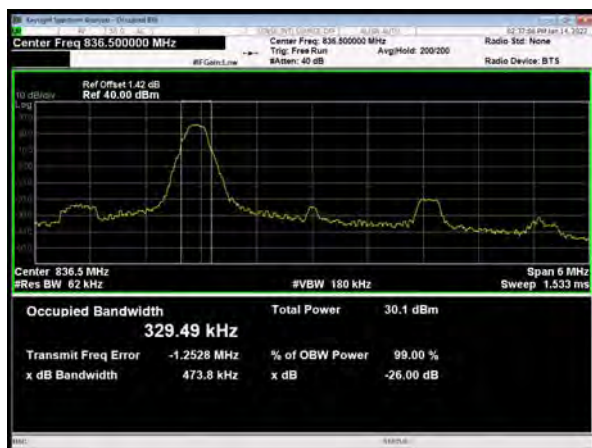

### LTE Band 26 16QAM 5MHz CH-Middle

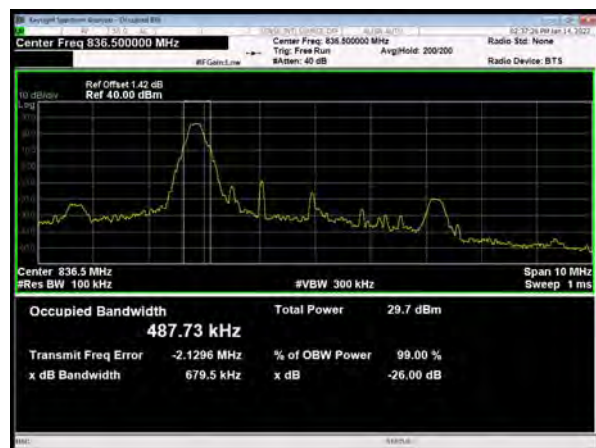

### LTE Band 26 16QAM 3MHz CH-High

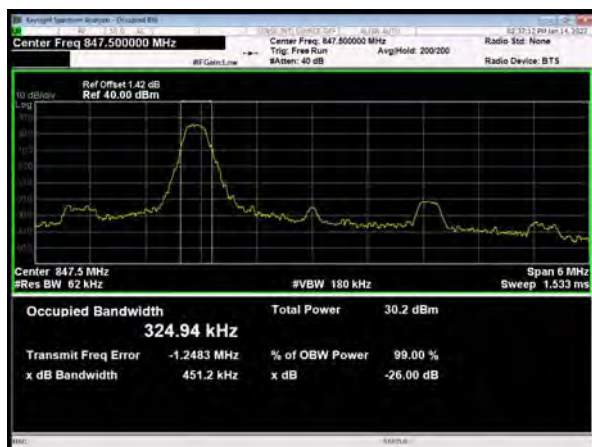

### LTE Band 26 16QAM 5MHz CH-High

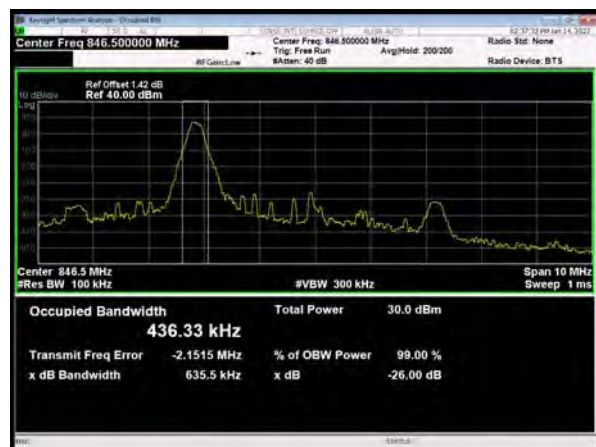

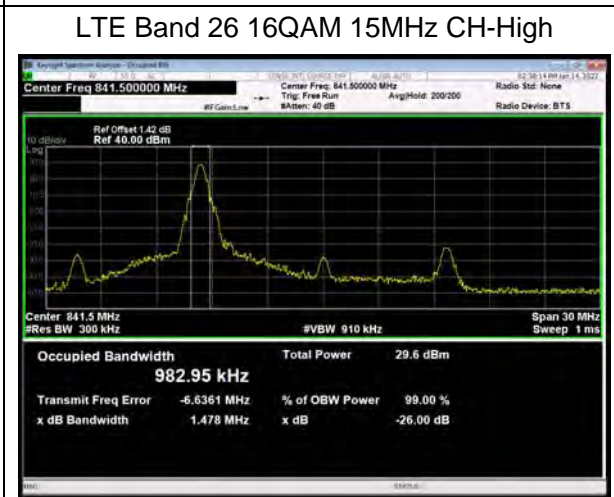
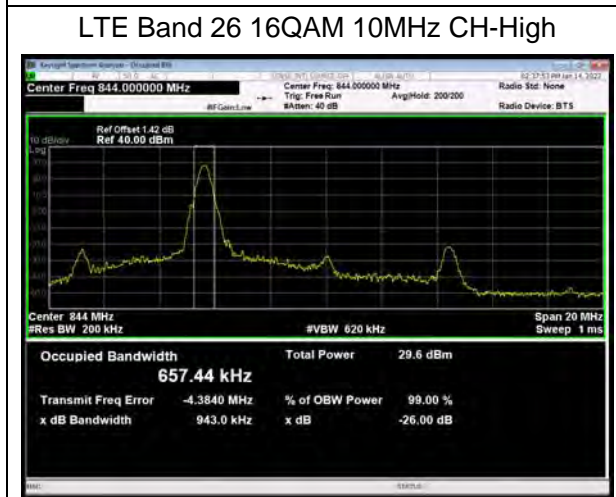
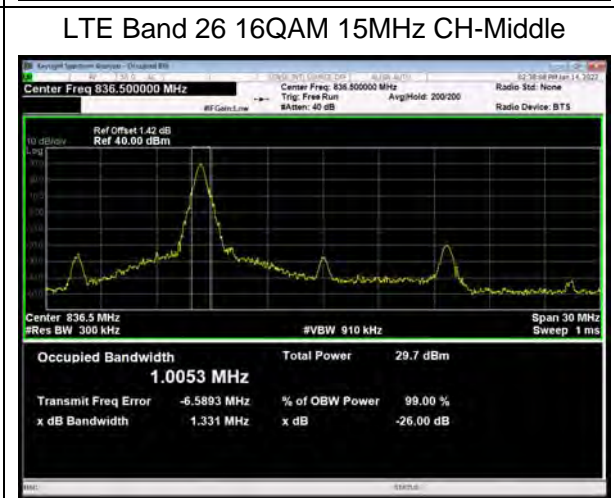
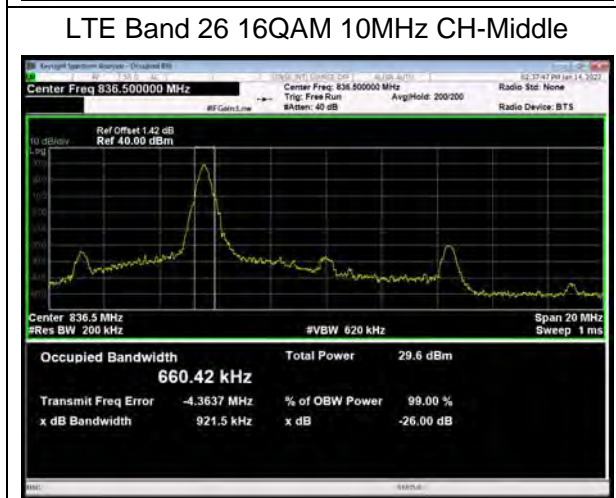
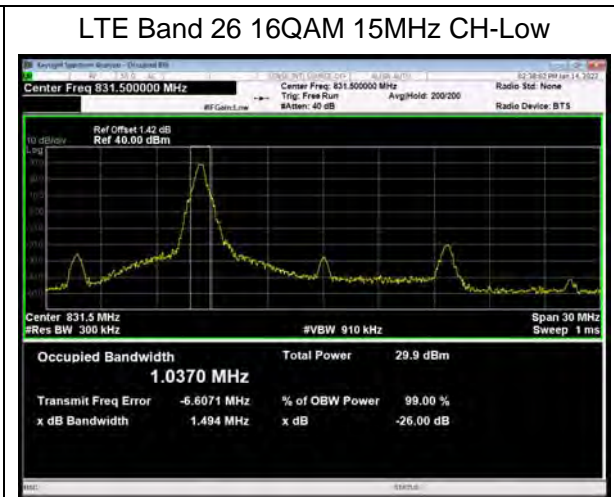
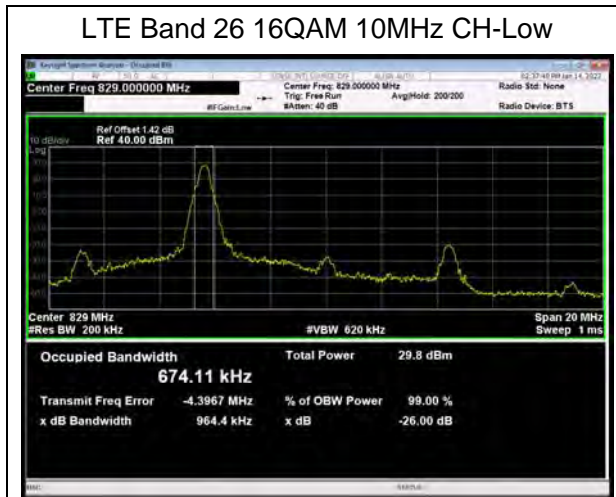



100% RB

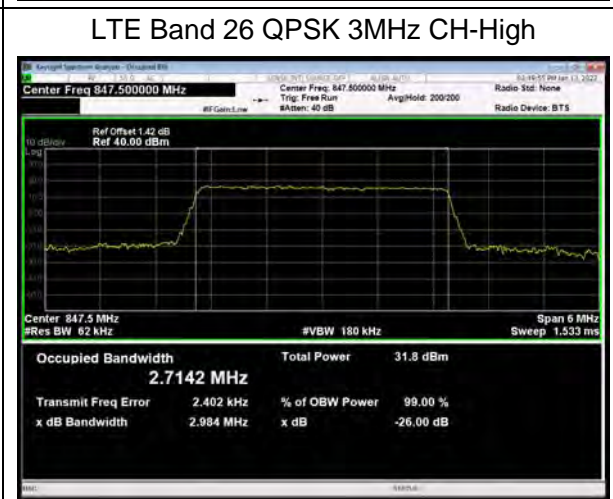
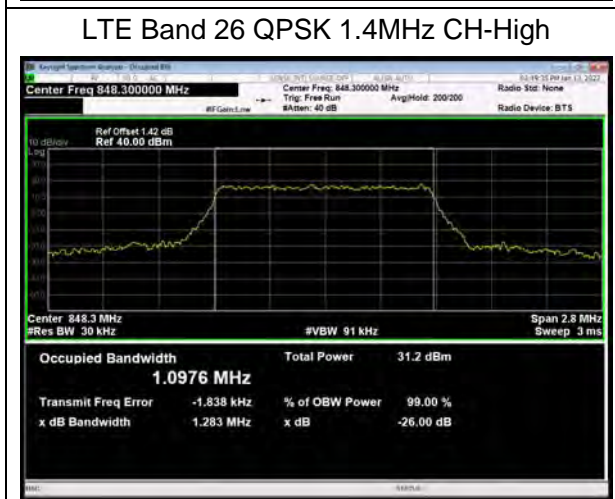
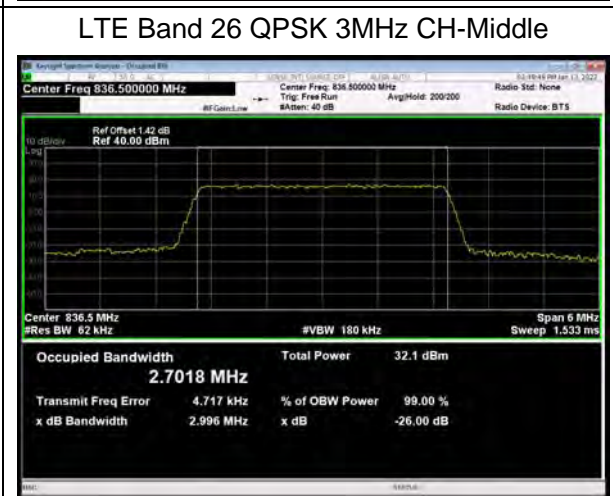
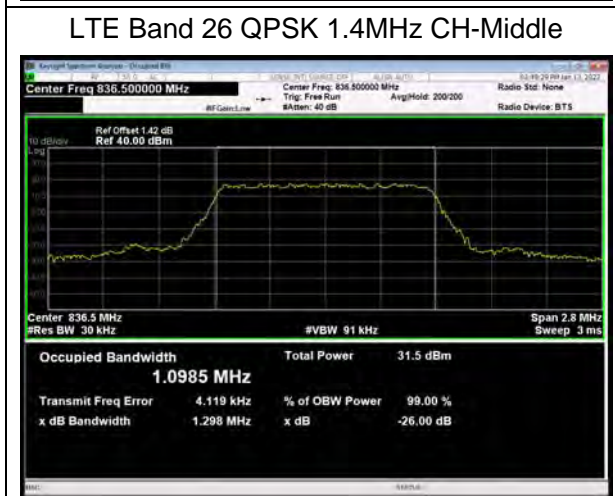
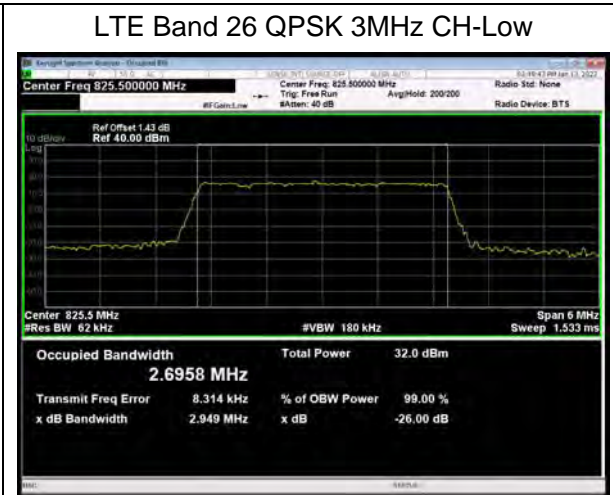
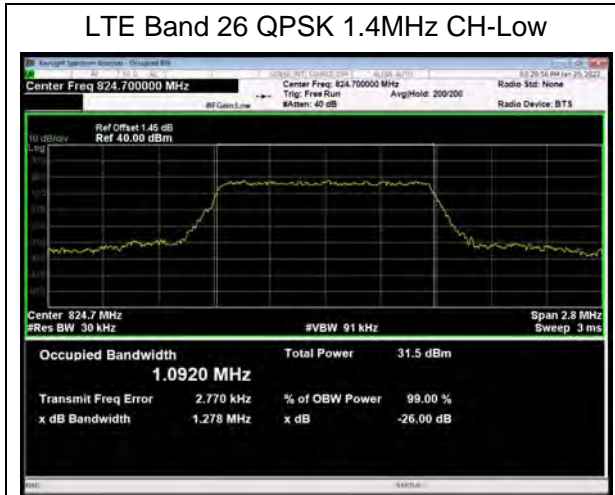



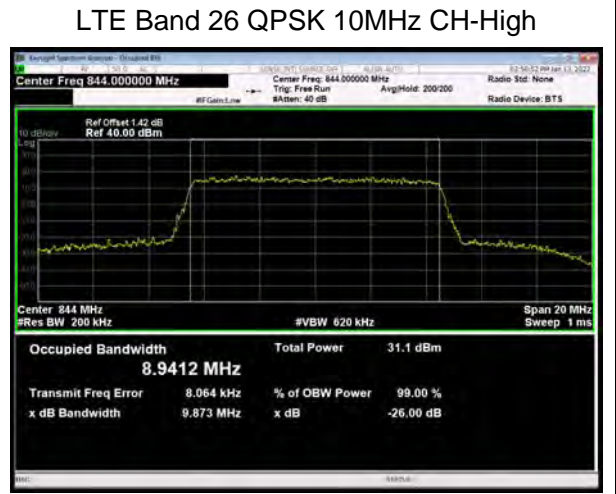
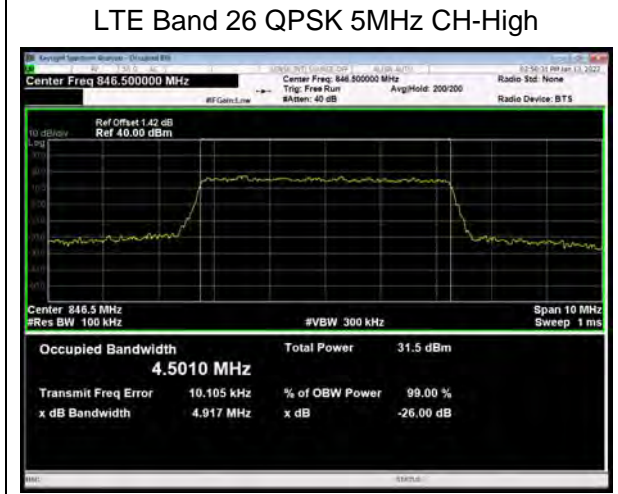
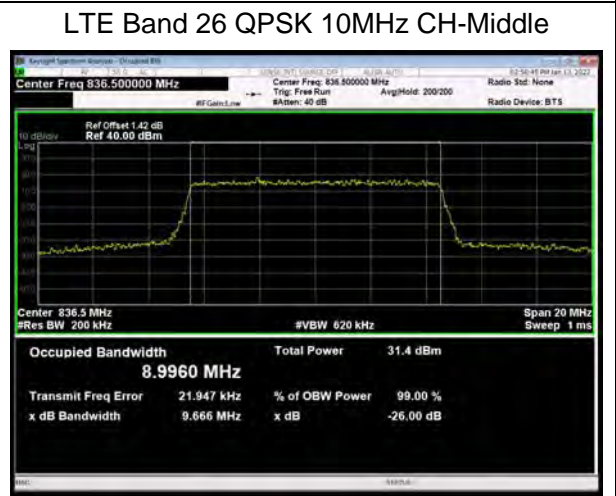
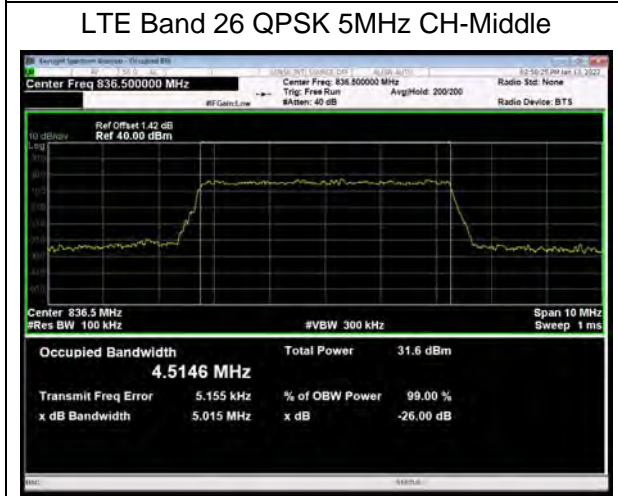
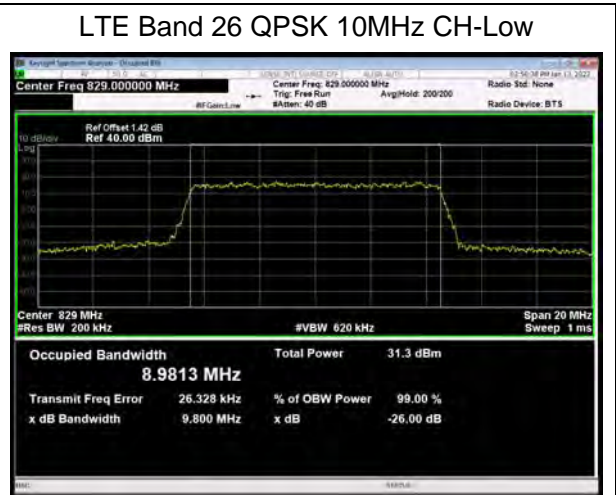
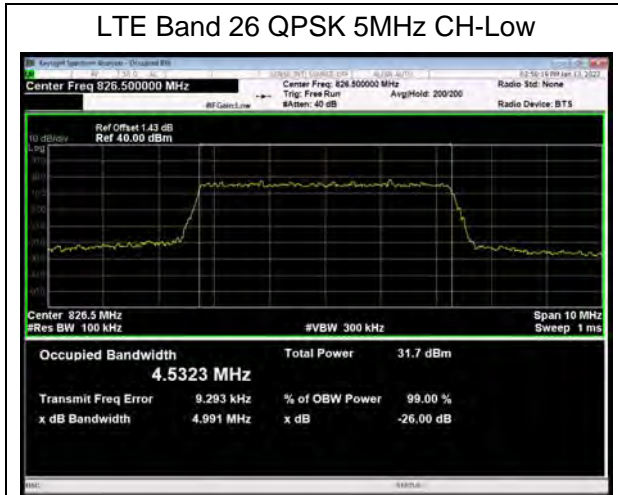

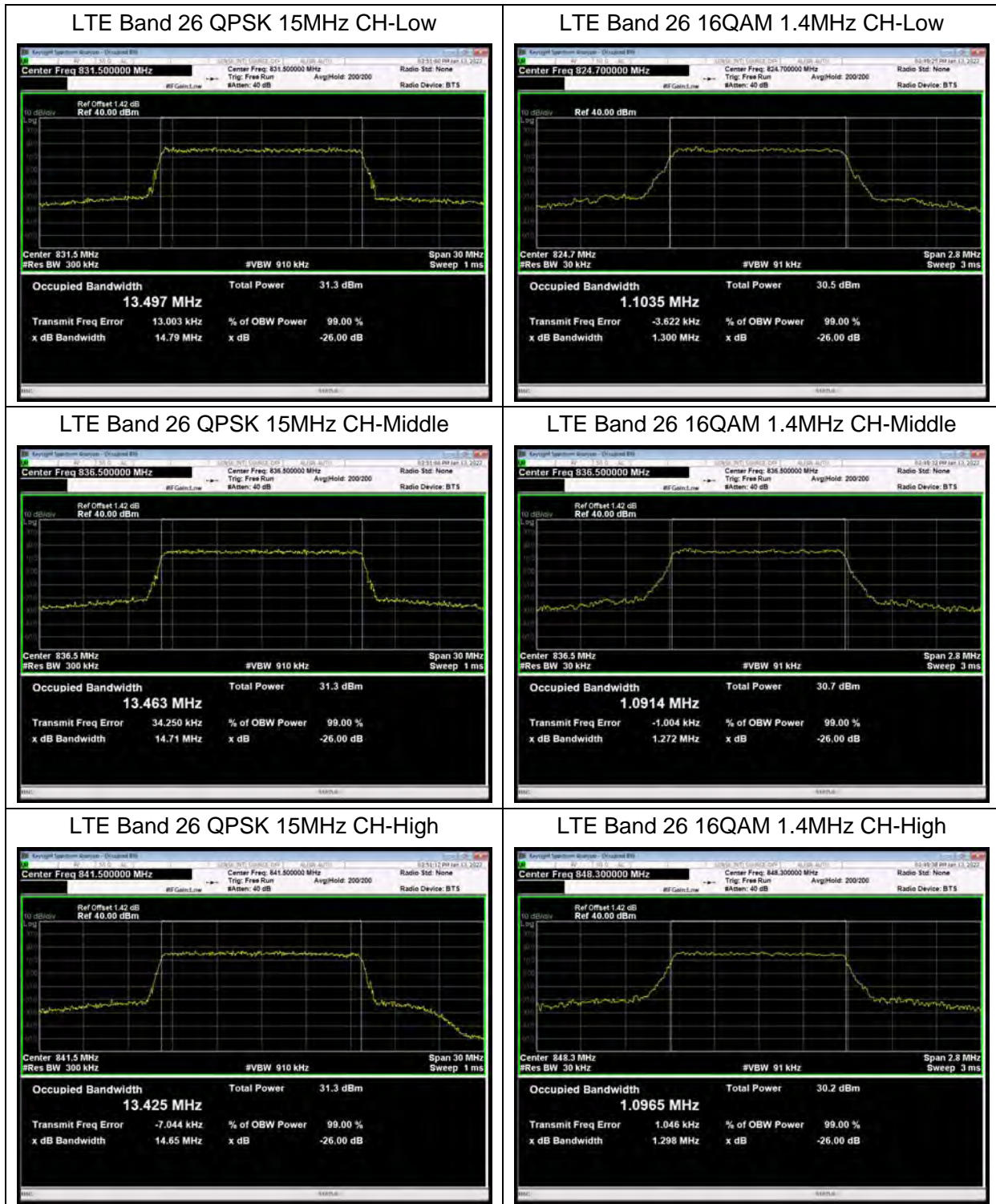



### LTE Band 26 16QAM 3MHz CH-Low

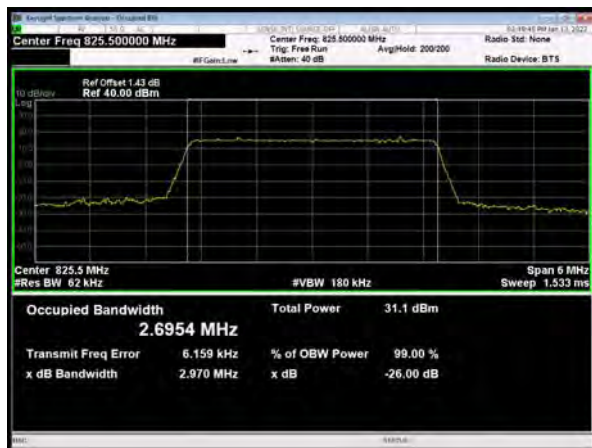

### LTE Band 26 16QAM 5MHz CH-Low

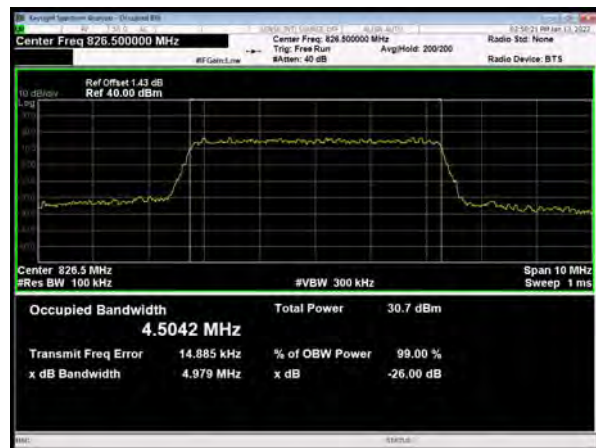

### LTE Band 26 16QAM 3MHz CH-Middle

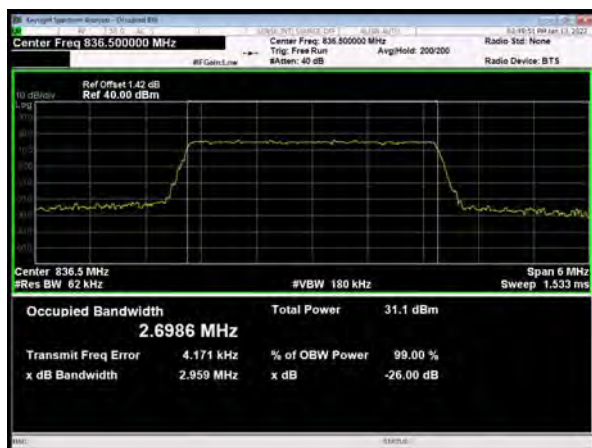

### LTE Band 26 16QAM 5MHz CH-Middle

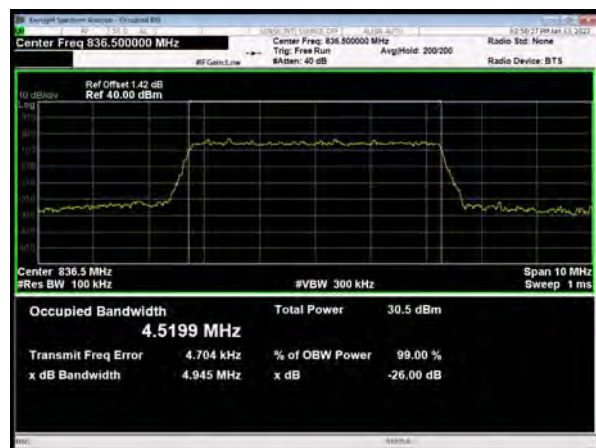

### LTE Band 26 16QAM 3MHz CH-High

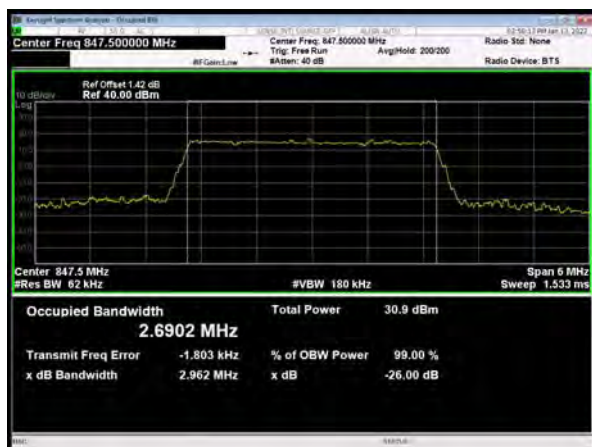

### LTE Band 26 16QAM 5MHz CH-High

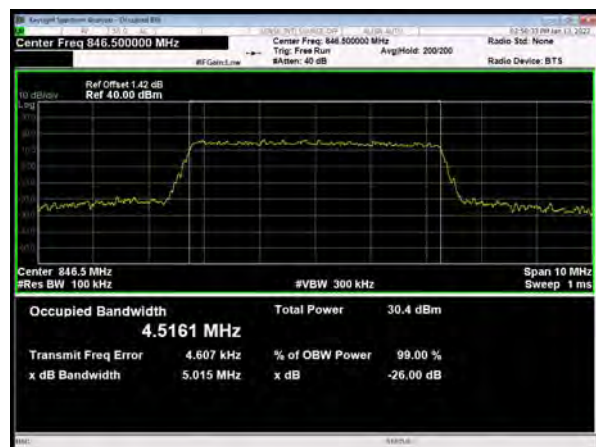

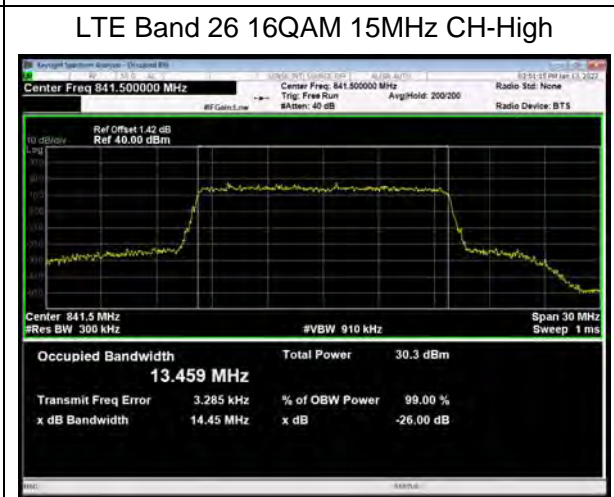
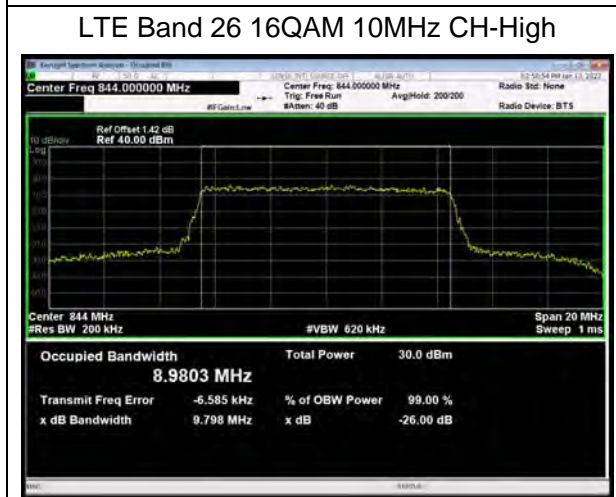
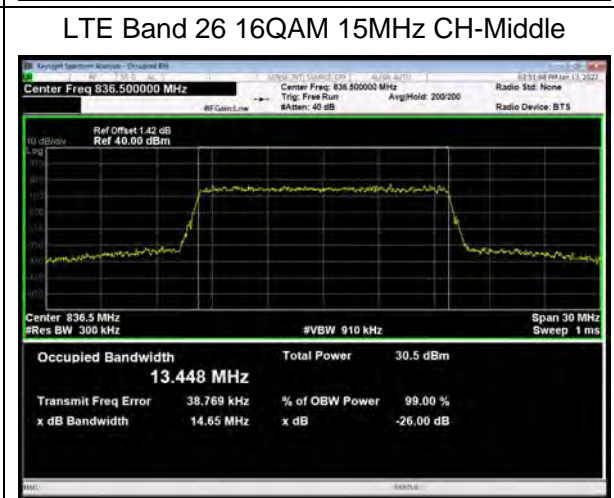
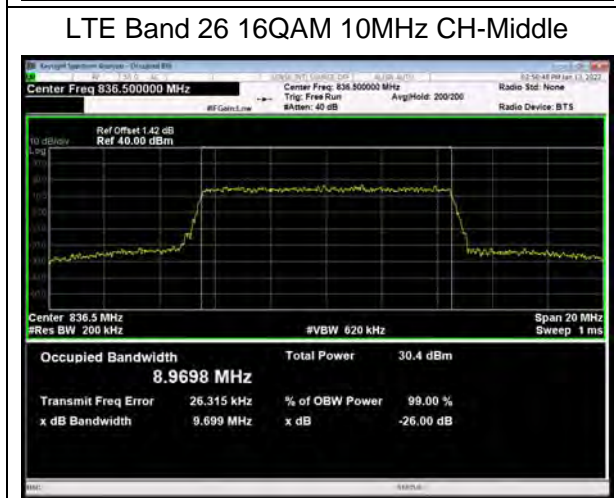
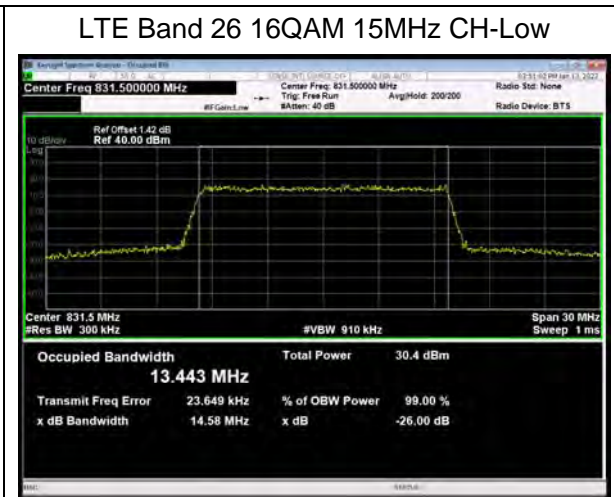
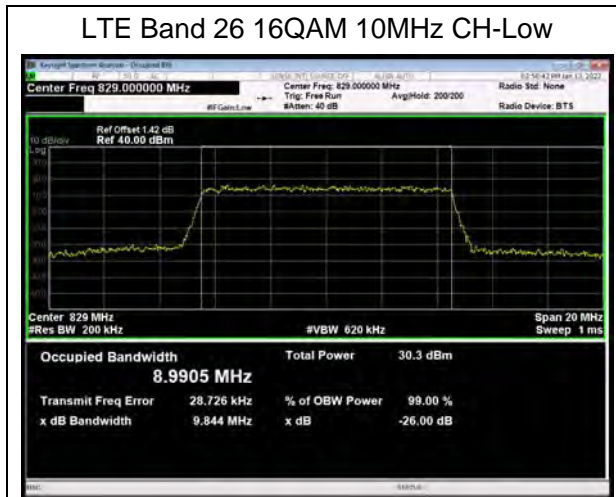

### 5.3. Band Edge Compliance

#### Ambient condition

Temperature	Relative humidity	Pressure
23°C ~25°C	45%~50%	101.5kPa

#### Method of Measurement

The EUT was connected to Spectrum Analyzer and Base Station Simulator via power Splitter. The band edge of the lowest and highest channels were measured. The average detector is used. RBW is set to  $\geq 1\%EBW$ , VBW is set to 3x RBW.

Spectrum analyzer plots are included on the following pages.

#### Test Setup

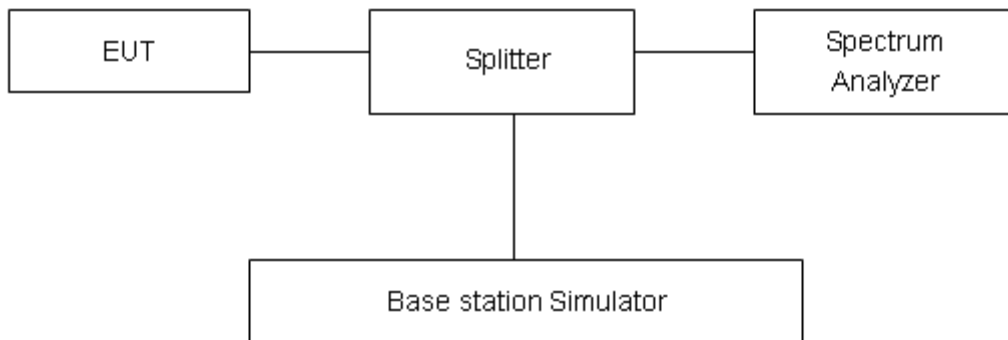

#### Limits

Rule Part 22.917(a) specifies that “The power of any emission outside of the authorized operating frequency ranges must be attenuated below the transmitting power (P) by a factor of at least 43 + 10 log(P) dB.”

Limit	-13 dBm
-------	---------

#### Measurement Uncertainty

The assessed measurement uncertainty to ensure 95% confidence level for the normal distribution is with the coverage factor  $k = 1.96$ ,  $U=0.684dB$ .

Test Result:

GSM 850 CH-Low

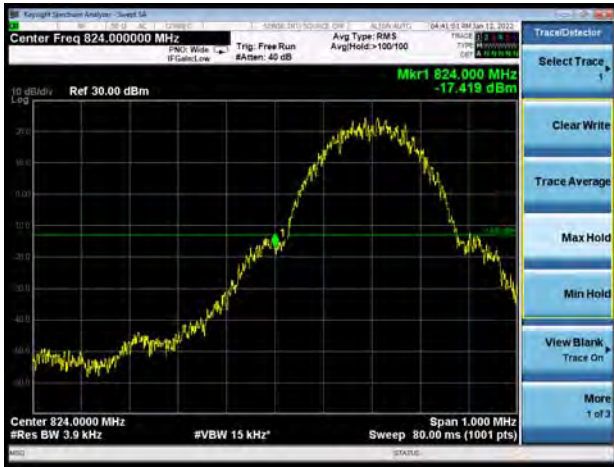

GSM 850 CH-High

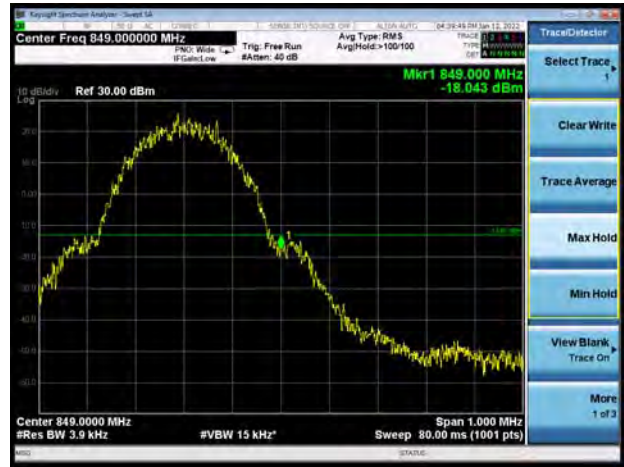

GSM 850 GPRS CH-Low

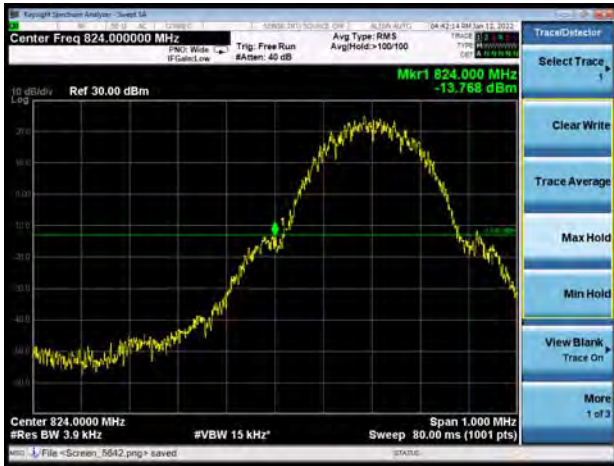

GSM 850 GPRS CH-High

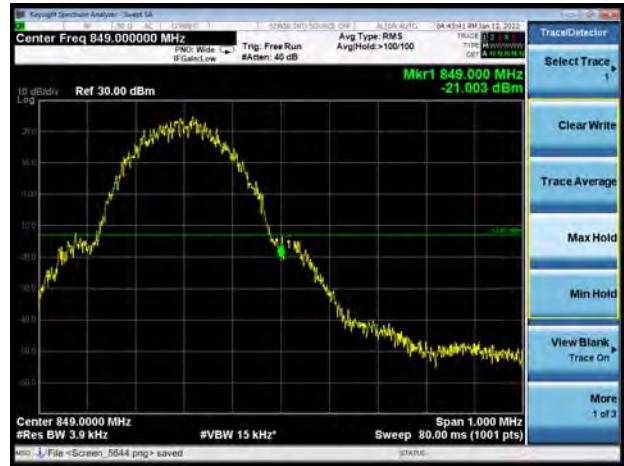

GSM 850 EGPRS CH-Low



GSM 850 EGPRS CH-High



WCDMA Band V CH-Low



WCDMA Band V CH-High



LTE Band 5 QPSK 1.4MHz CH-Low 1RB

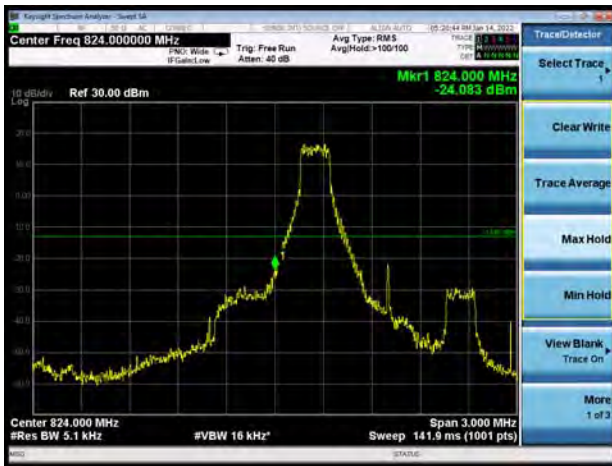

LTE Band 5 QPSK 1.4MHz CH-High 1RB

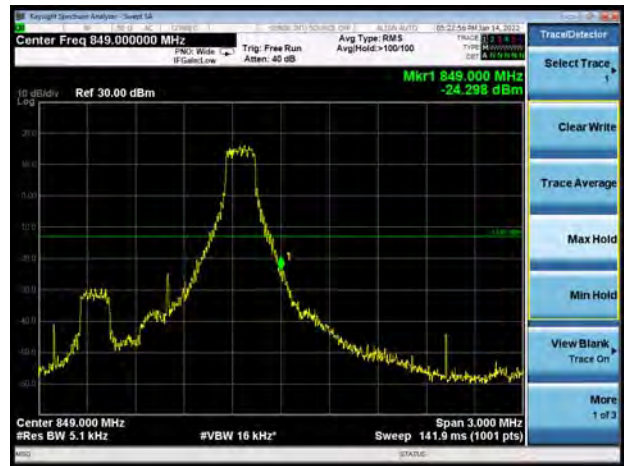

LTE Band 5 QPSK 1.4MHz CH-Low 100%RB

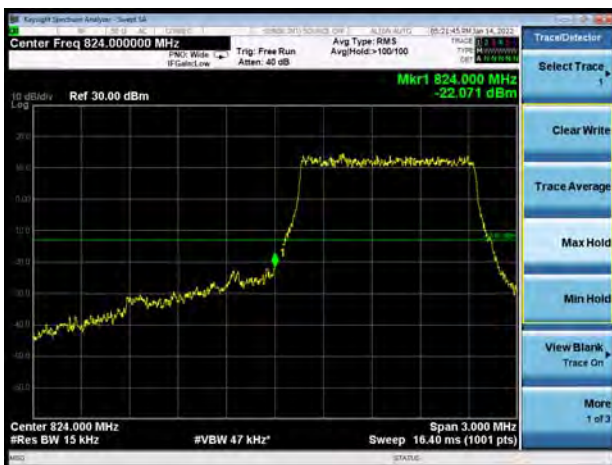

LTE Band 5 QPSK 1.4MHz CH-High 100%RB

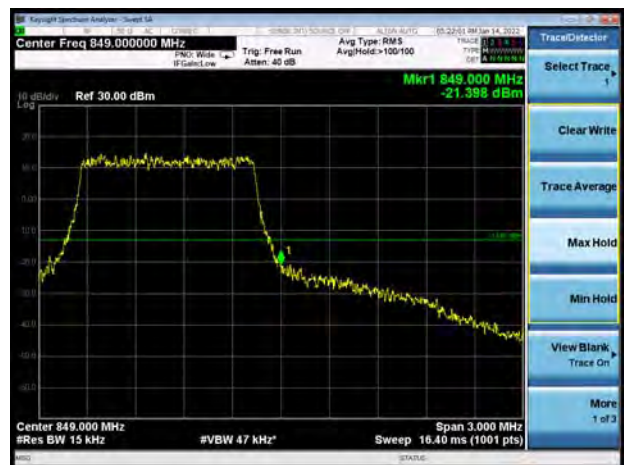

LTE Band 5 QPSK 3MHz CH-Low 1RB

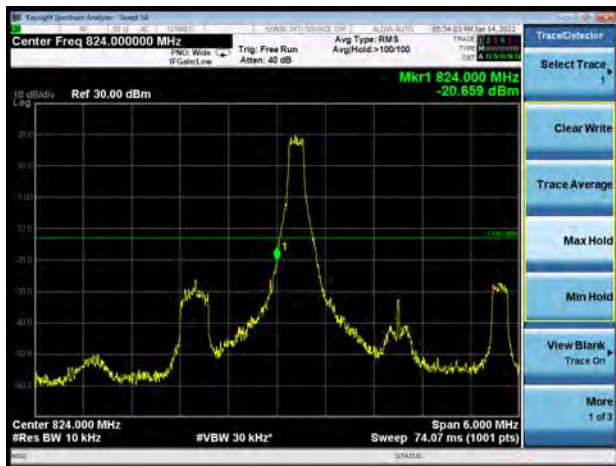

LTE Band 5 QPSK 3MHz CH-High 1RB

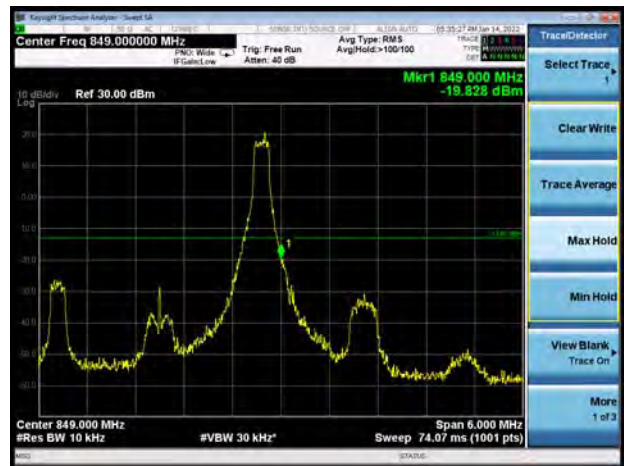



LTE Band 5 QPSK 3MHz CH-Low 100%RB

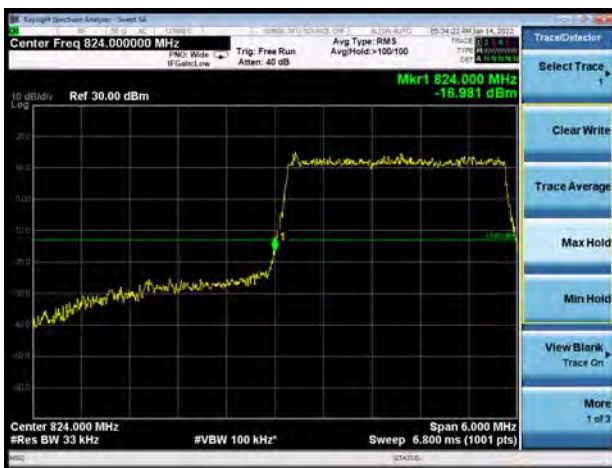

LTE Band 5 QPSK 3MHz CH-High 100%RB

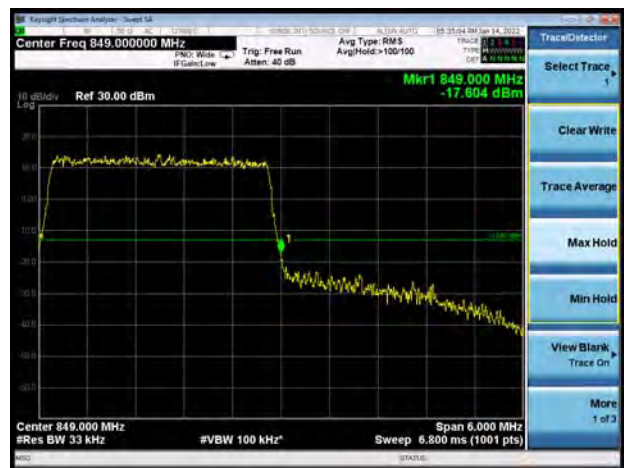

LTE Band 5 QPSK 5MHz CH-Low 1RB



LTE Band 5 QPSK 5MHz CH-High 1RB



LTE Band 5 QPSK 5MHz CH-Low 100%RB

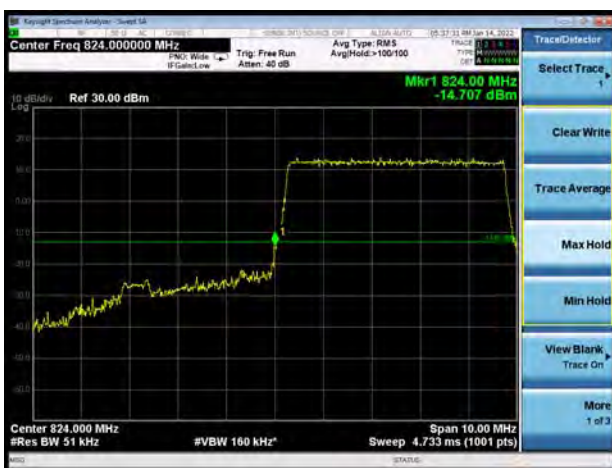

LTE Band 5 QPSK 5MHz CH-High 100%RB

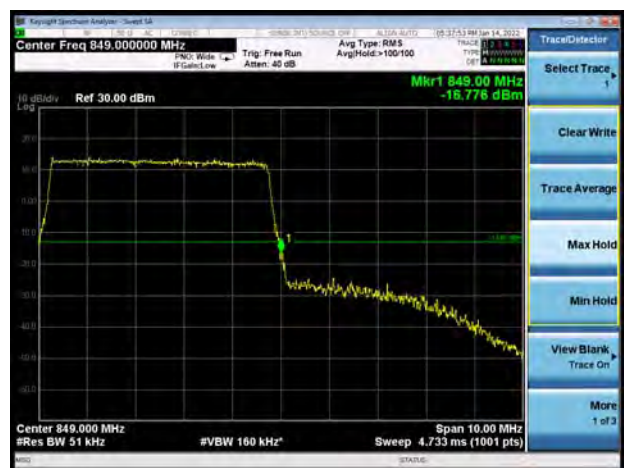

LTE Band 5 QPSK 10MHz CH-Low 1RB

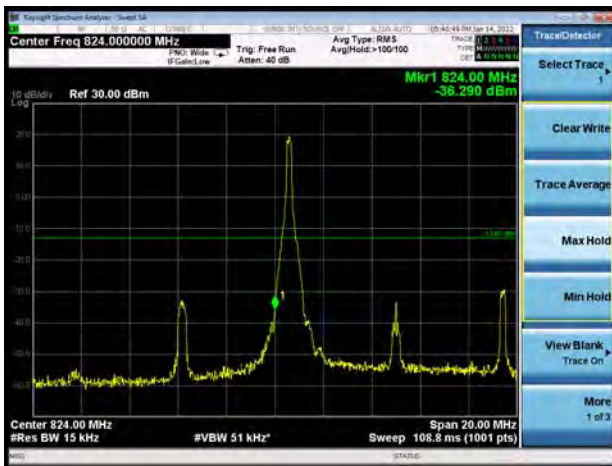

LTE Band 5 QPSK 10MHz CH-High 1RB

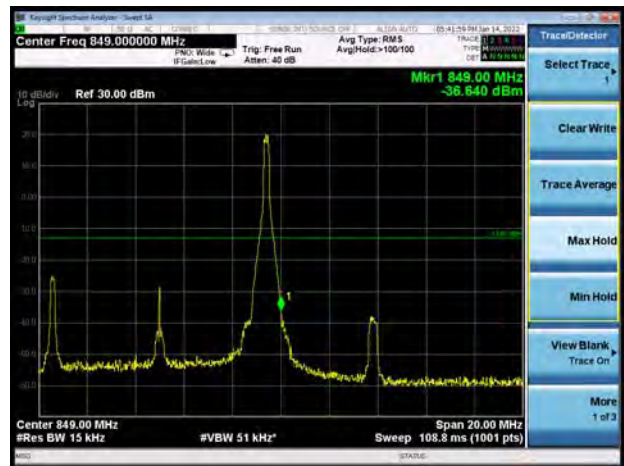

LTE Band 5 QPSK 10MHz CH-Low 100%RB

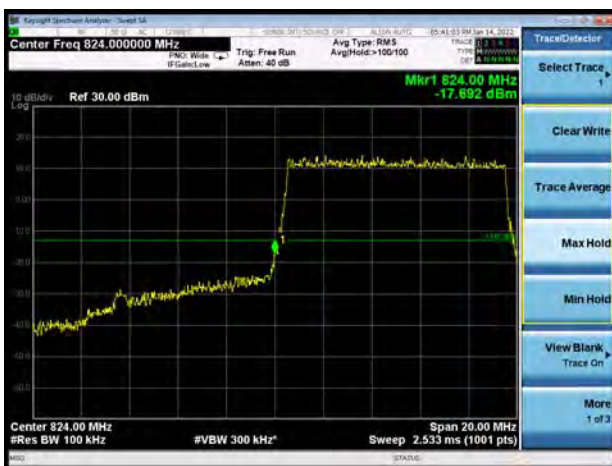

LTE Band 5 QPSK 10MHz CH-High 100%RB



LTE Band 5 16QAM 1.4MHz CH-Low 1RB

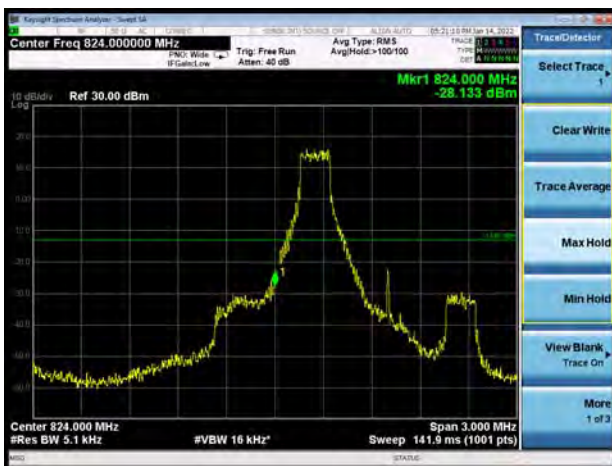

LTE Band 5 16QAM 1.4MHz CH-High 1RB

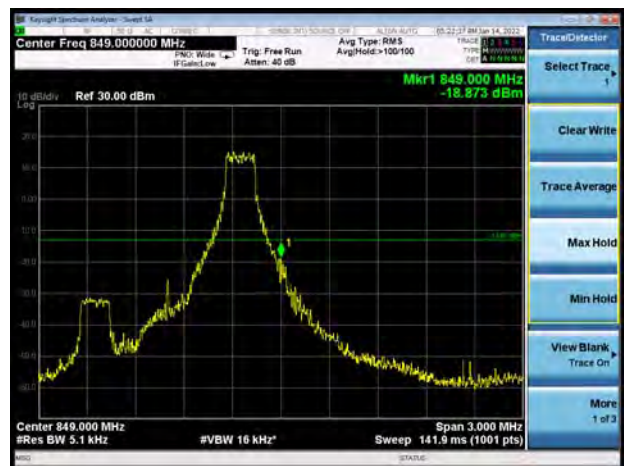

LTE Band 5 16QAM 1.4MHz CH-Low 100%RB

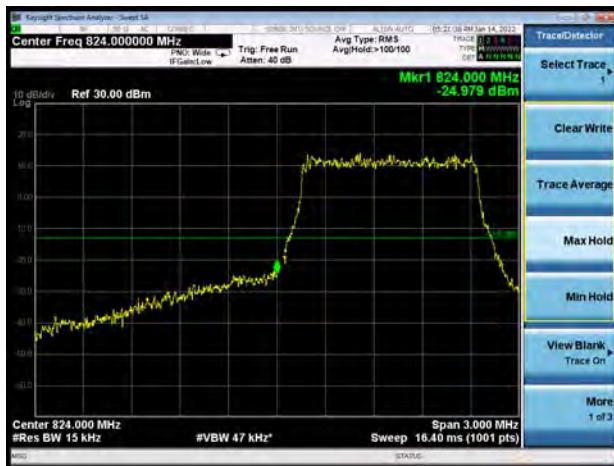

LTE Band 5 16QAM 1.4MHz CH-High 100%RB



LTE Band 5 16QAM 3MHz CH-Low 1RB

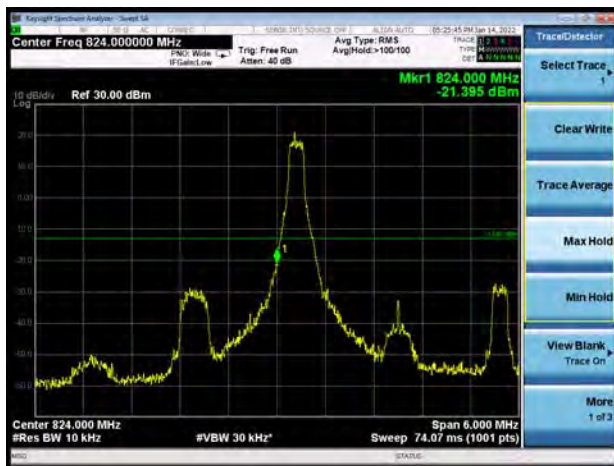

LTE Band 5 16QAM 3MHz CH-High 1RB

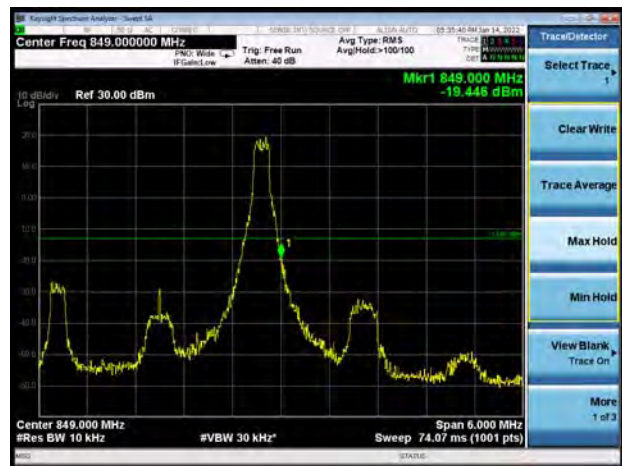

LTE Band 5 16QAM 3MHz CH-Low 100%RB



LTE Band 5 16QAM 3MHz CH-High 100%RB

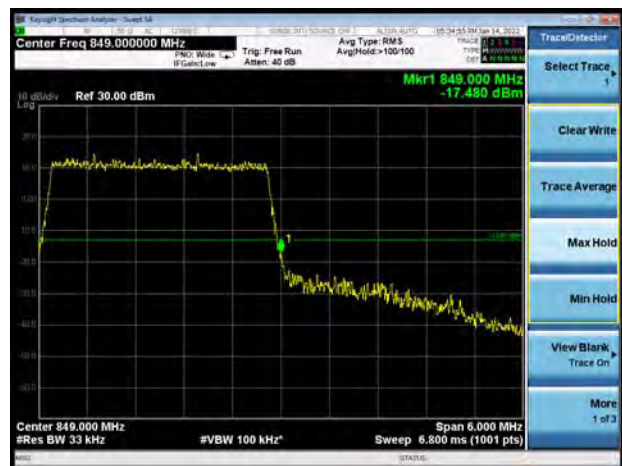

LTE Band 5 16QAM 5MHz CH-Low 1RB

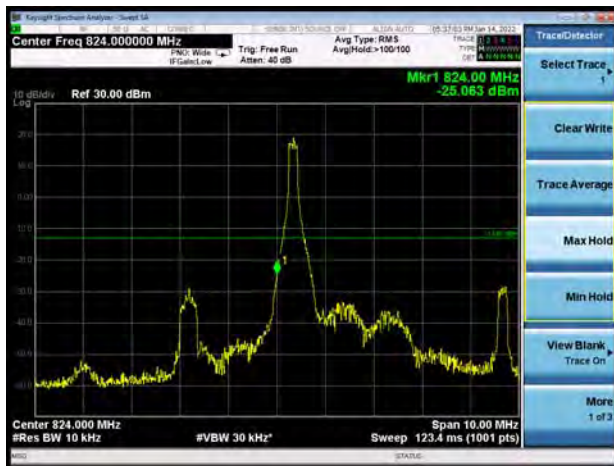

LTE Band 5 16QAM 5MHz CH-High 1RB



LTE Band 5 16QAM 5MHz CH-Low 100%RB

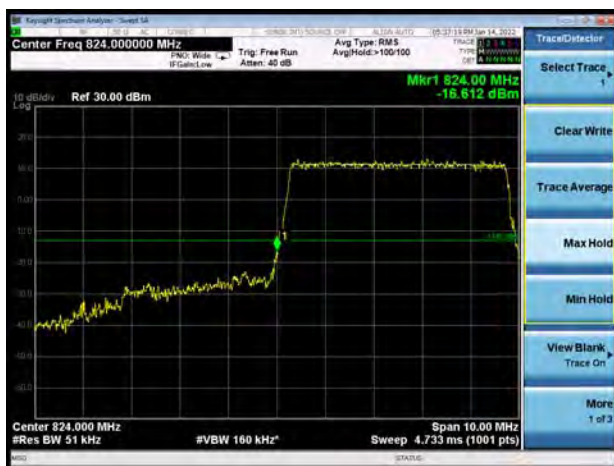

LTE Band 5 16QAM 5MHz CH-High 100%RB

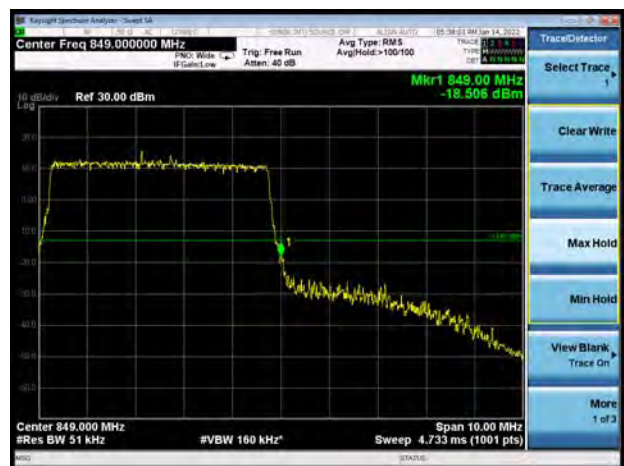

LTE Band 5 16QAM 10MHz CH-Low 1RB

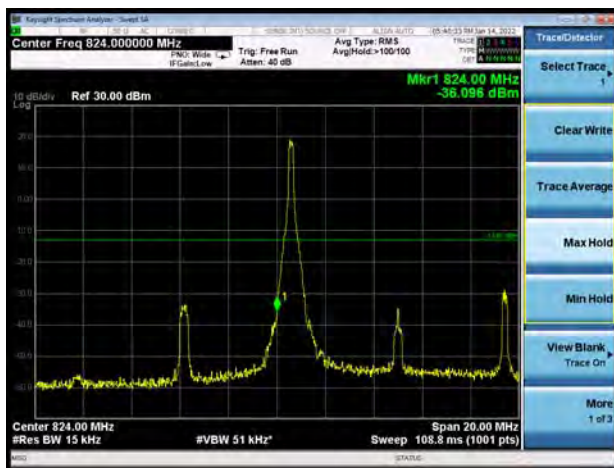

LTE Band 5 16QAM 10MHz CH-High 1RB

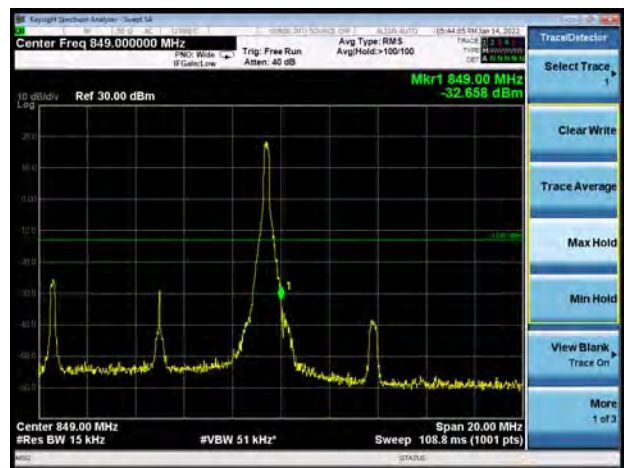

LTE Band 5 16QAM 10MHz CH-Low 100%RB

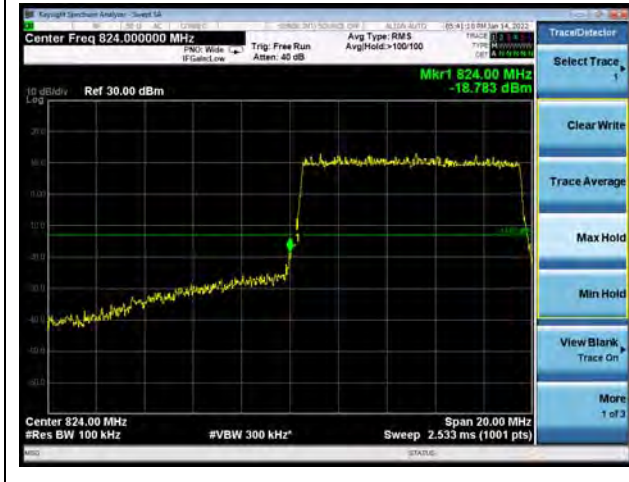

LTE Band 5 16QAM 10MHz CH-High 100%RB



LTE Band 26 QPSK 1.4MHz CH-Low 1RB



LTE Band 26 QPSK 1.4MHz CH-High 1RB



LTE Band 26 QPSK 1.4MHz CH-Low 100%RB

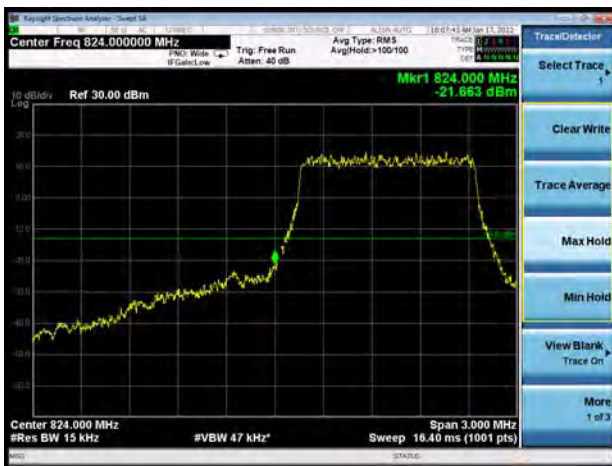

LTE Band 26 QPSK 1.4MHz CH-High 100%RB

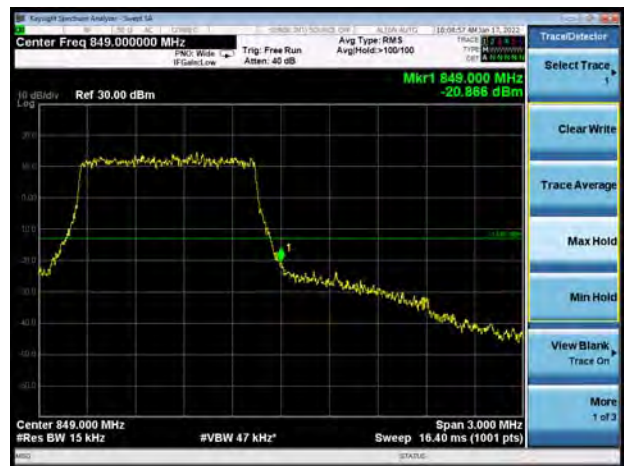

LTE Band 26 QPSK 3MHz CH-Low 1RB

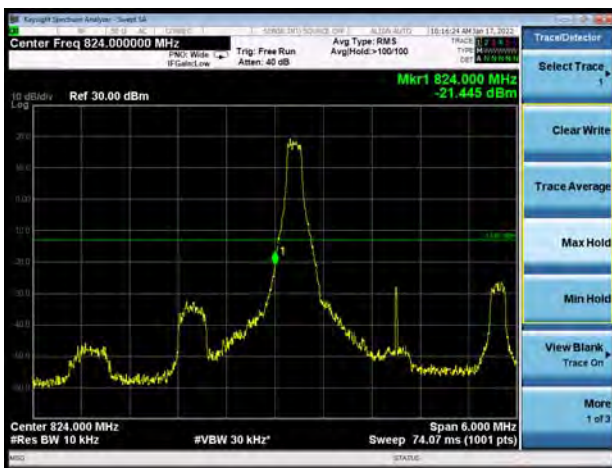

LTE Band 26 QPSK 3MHz CH-High 1RB

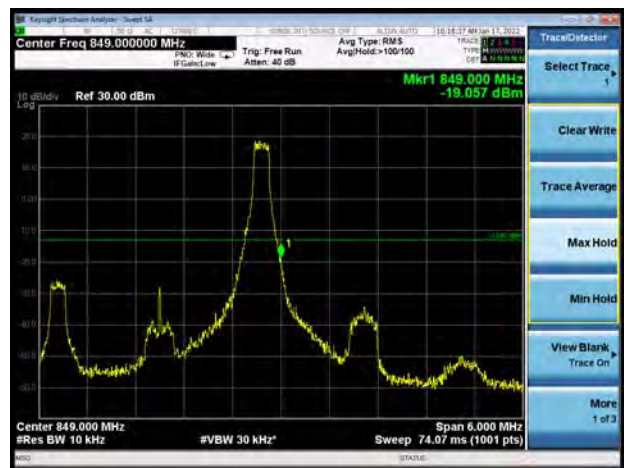

LTE Band 26 QPSK 3MHz CH-Low 100%RB



LTE Band 26 QPSK 3MHz CH-High 100%RB



LTE Band 26 QPSK 5MHz CH-Low 1RB



LTE Band 26 QPSK 5MHz CH-High 1RB



LTE Band 26 QPSK 5MHz CH-Low 100%RB



LTE Band 26 QPSK 5MHz CH-High 100%RB



LTE Band 26 QPSK 10MHz CH-Low 1RB

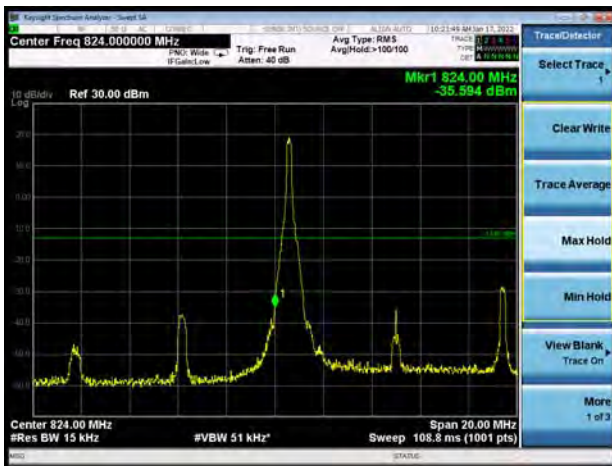

LTE Band 26 QPSK 10MHz CH-High 1RB

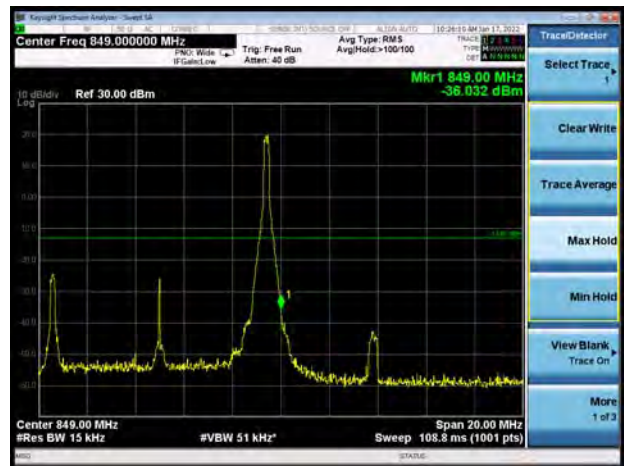

LTE Band 26 QPSK 10MHz CH-Low 100%RB



LTE Band 26 QPSK 10MHz CH-High 100%RB

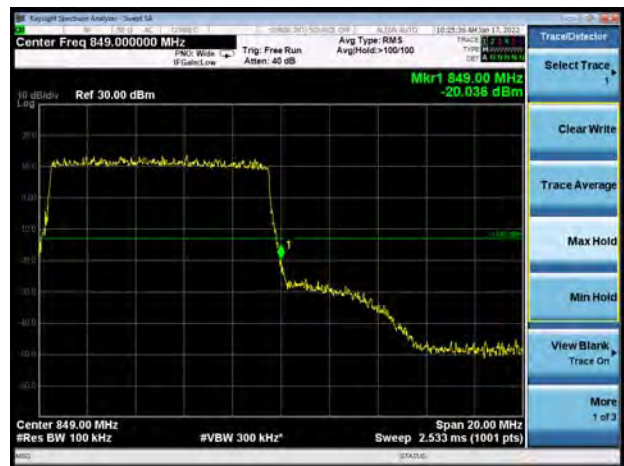

LTE Band 26 QPSK 15MHz CH-Low 1RB

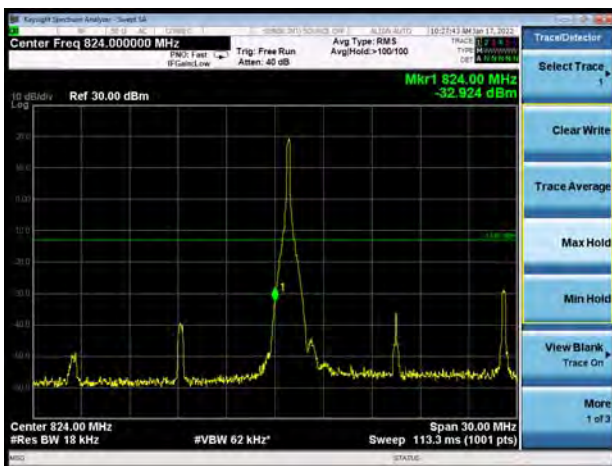

LTE Band 26 QPSK 15MHz CH-High 1RB

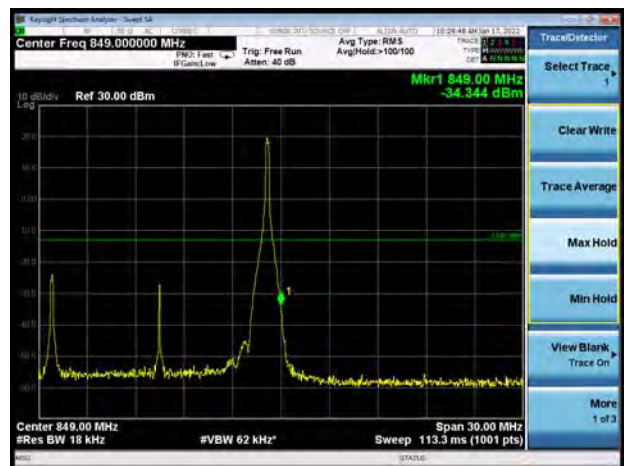



LTE Band 26 QPSK 15MHz CH-Low 100%RB



LTE Band 26 QPSK 15MHz CH-High 100%RB



LTE Band 26 16QAM 1.4MHz CH-Low 1RB

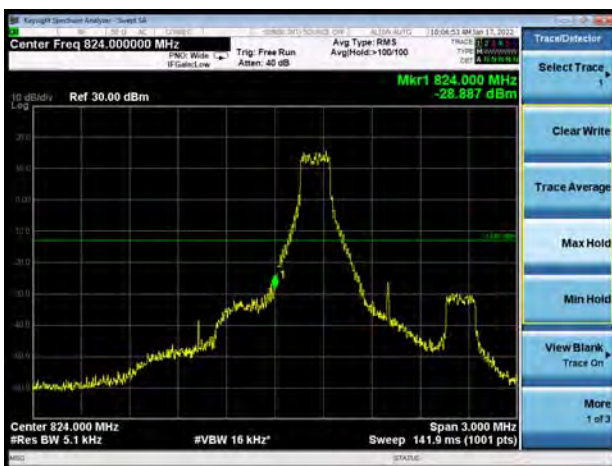

LTE Band 26 16QAM 1.4MHz CH-High 1RB

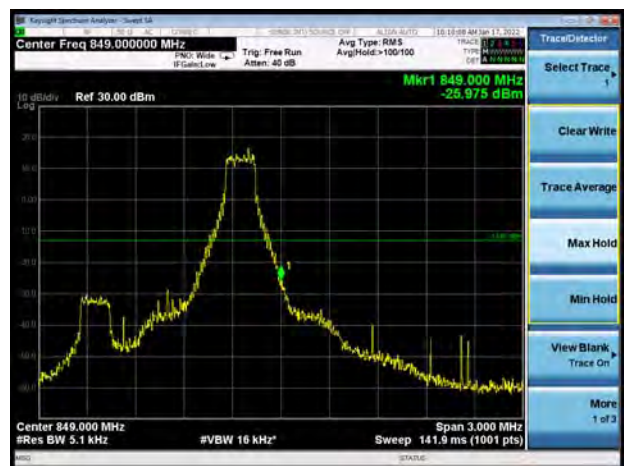

LTE Band 26 16QAM 1.4MHz CH-Low 100%RB



LTE Band 26 16QAM 1.4MHz CH-High 100%RB

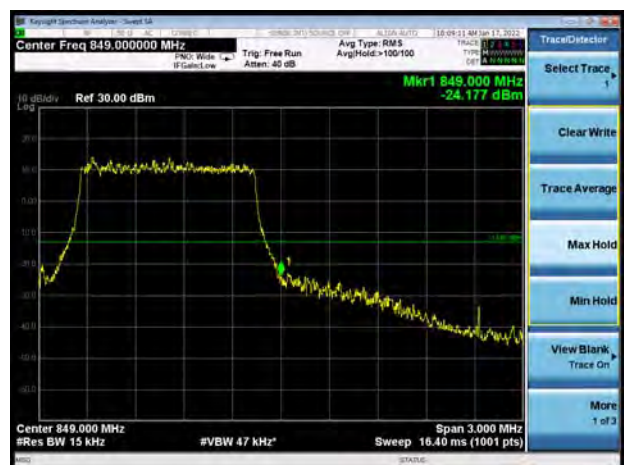

LTE Band 26 16QAM 3MHz CH-Low 1RB

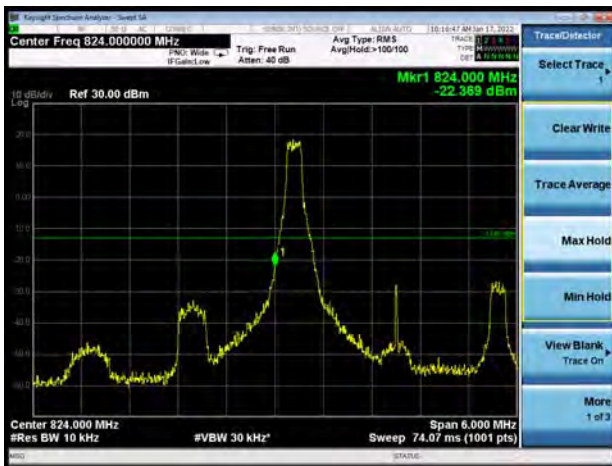

LTE Band 26 16QAM 3MHz CH-High 1RB

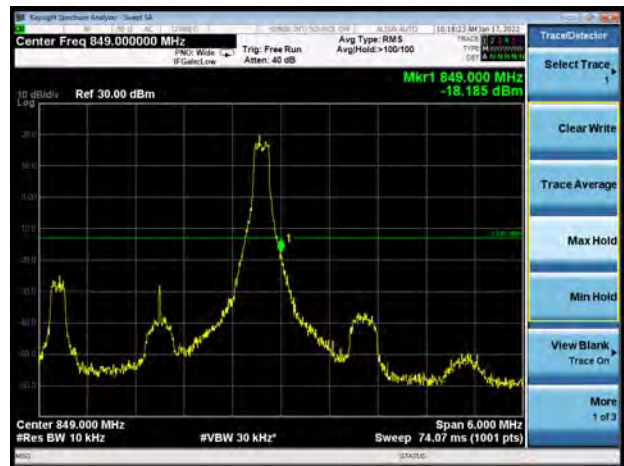

LTE Band 26 16QAM 3MHz CH-Low 100%RB

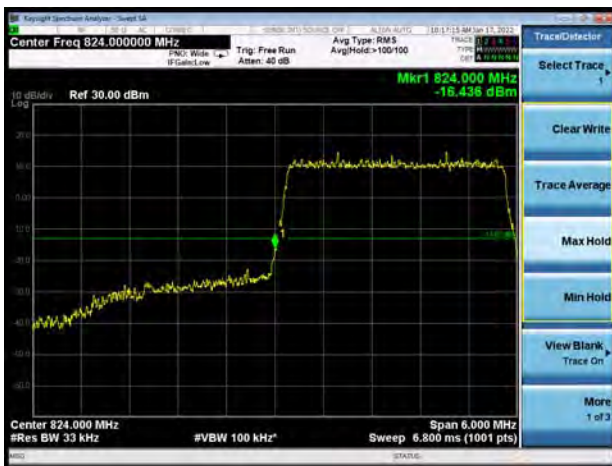

LTE Band 26 16QAM 3MHz CH-High 100%RB

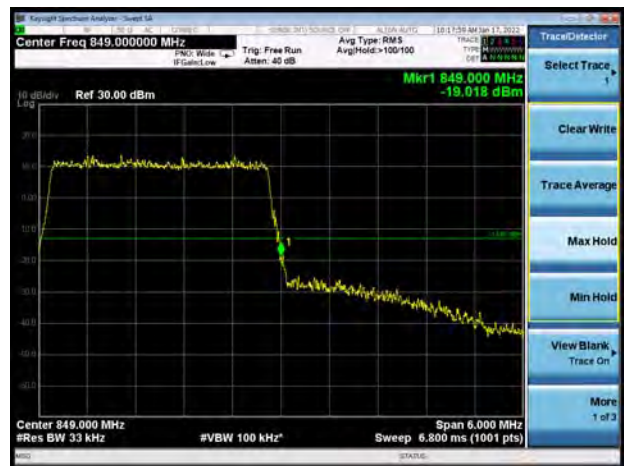

LTE Band 26 16QAM 5MHz CH-Low 1RB

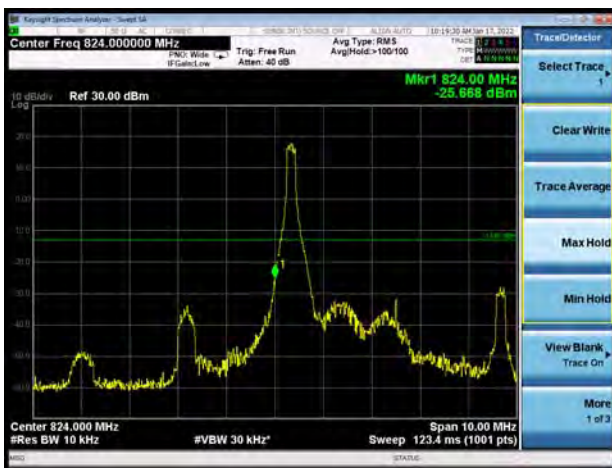

LTE Band 26 16QAM 5MHz CH-High 1RB



LTE Band 26 16QAM 5MHz CH-Low 100%RB



LTE Band 26 16QAM 5MHz CH-High 100%RB



LTE Band 26 16QAM 10MHz CH-Low 1RB

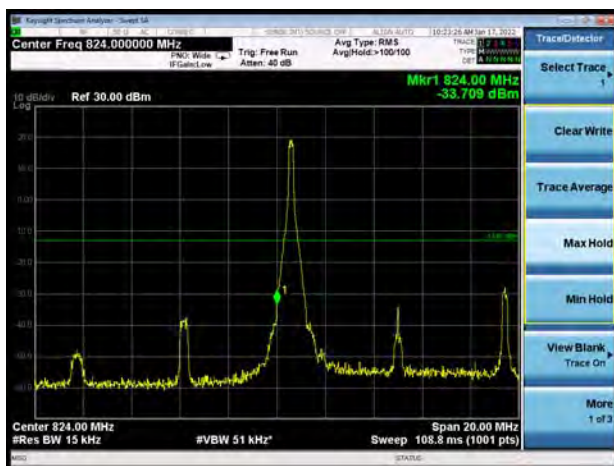

LTE Band 26 16QAM 10MHz CH-High 1RB

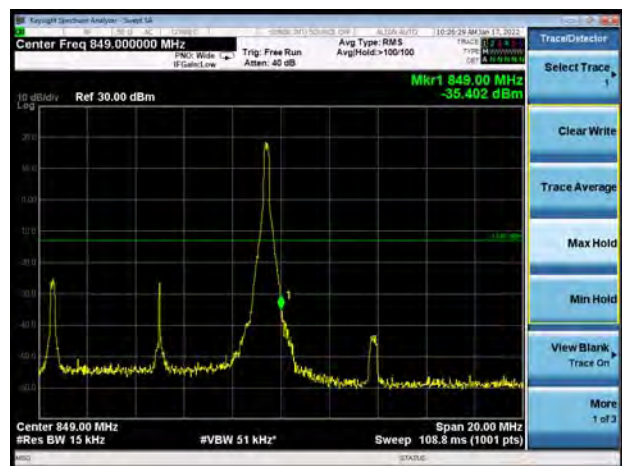

LTE Band 26 16QAM 10MHz CH-Low 100%RB

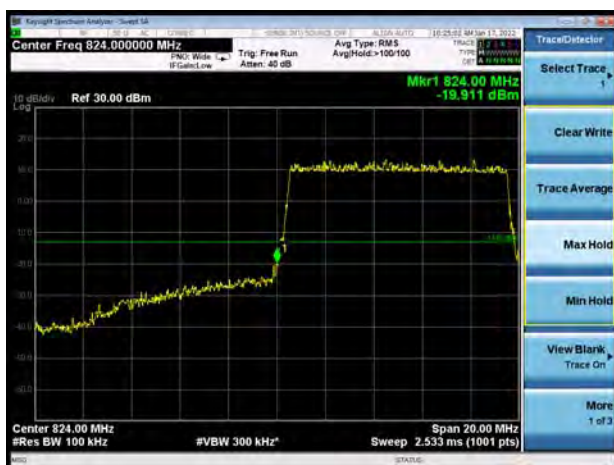

LTE Band 26 16QAM 10MHz CH-High 100%RB

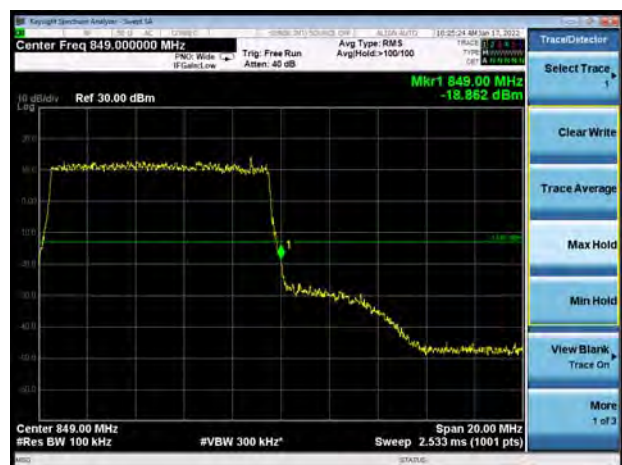

LTE Band 26 16QAM 15MHz CH-Low 1RB

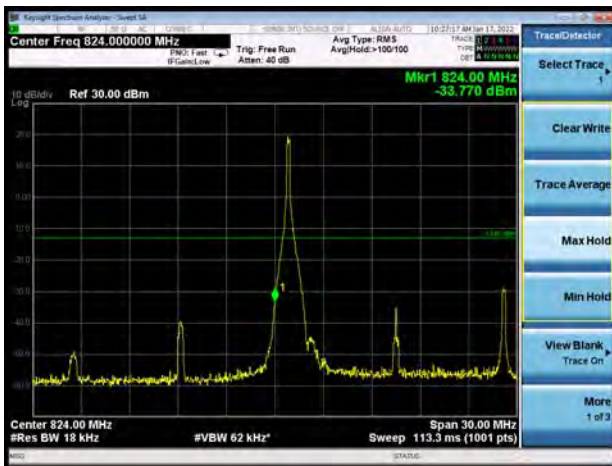

LTE Band 26 16QAM 15MHz CH-High 1RB

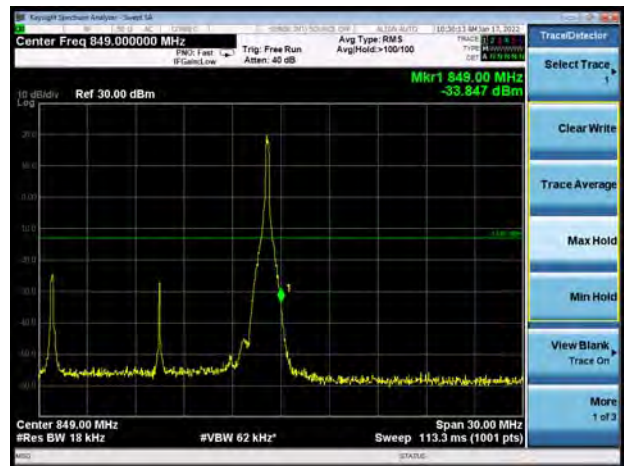

LTE Band 26 16QAM 15MHz CH-Low 100%RB

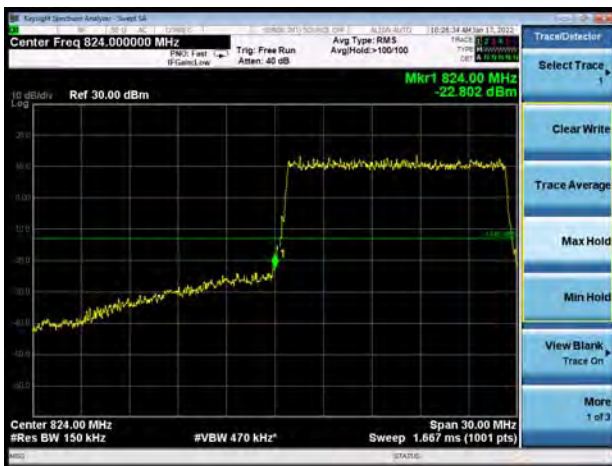

LTE Band 26 16QAM 15MHz CH-High 100%RB



### 5.4. Peak-to-Average Power Ratio (PAPR)

#### Ambient condition

Temperature	Relative humidity	Pressure
23°C ~25°C	45%~50%	101.5kPa

#### Methods of Measurement

Measure the total peak power and record as  $P_{Pk}$ . And measure the total average power and record as  $P_{Avg}$ . Both the peak and average power levels must be expressed in the same logarithmic units (e.g., dBm). Determine the PAPR from:

$$PAPR (dB) = P_{Pk} (dBm) - P_{Avg} (dBm).$$

#### Test Setup

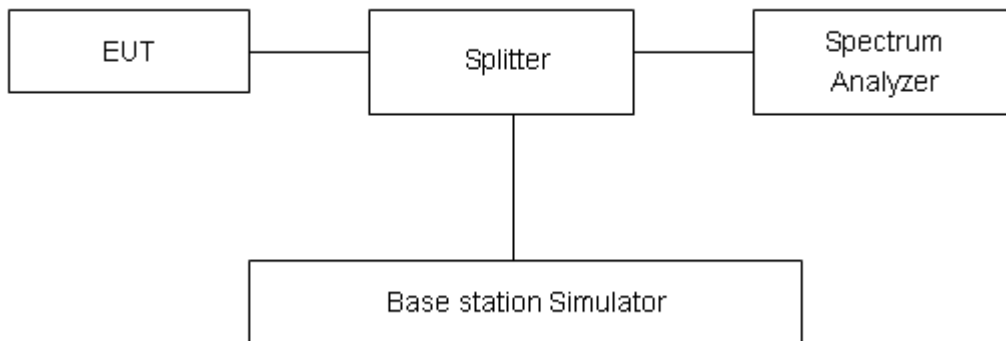

#### Limits

According to the Sec. 22.913(d), The peak-to-average ratio (PAR) of the transmission must not exceed 13 dB.

#### Measurement Uncertainty

The assessed measurement uncertainty to ensure 95% confidence level for the normal distribution is with the coverage factor  $k = 2$ ,  $U = 0.4$  dB.

**Test Results**

Mode	Channel	Frequency (MHz)	Peak (dBm)	Avg (dBm)	PAPR (dB)	Limit (dB)	Conclusion
<b>GSM 850 (GMSK)</b>	128	824.2	33.24	30.57	2.67	≤13	PASS
	190	836.6	33.20	30.54	2.66	≤13	PASS
	251	848.8	33.18	30.52	2.66	≤13	PASS
<b>GPRS 850 (GMSK)</b>	128	824.2	33.70	31.03	2.67	≤13	PASS
	190	836.6	33.67	31.00	2.67	≤13	PASS
	251	848.8	33.77	31.11	2.66	≤13	PASS
<b>EGPRS 850 (8PSK)</b>	128	824.2	30.87	25.07	5.80	≤13	PASS
	190	836.6	30.83	25.04	5.79	≤13	PASS
	251	848.8	30.86	25.08	5.78	≤13	PASS
<b>WCDMA Band V (RMC)</b>	4132	826.4	28.10	24.92	3.18	≤13	PASS
	4183	836.6	27.82	24.67	3.15	≤13	PASS
	4233	846.6	27.71	24.68	3.03	≤13	PASS

<b>LTE Band 5</b>								
Modulation	Bandwidth (MHz)	Channel	Frequency (MHz)	Peak (dBm)	Avg (dBm)	PAPR (dB)	Limit (dB)	Conclusion
<b>QPSK</b>	1.4	20407	824.7	29.25	23.71	5.54	≤13	PASS
		20525	836.5	29.13	23.69	5.44	≤13	PASS
		20643	848.3	28.36	23.68	4.68	≤13	PASS
	3	20415	825.5	29.27	23.74	5.53	≤13	PASS
		20525	836.5	29.19	23.77	5.42	≤13	PASS
		20635	847.5	28.49	23.72	4.77	≤13	PASS
	5	20425	826.5	29.27	23.70	5.57	≤13	PASS
		20525	836.5	29.20	23.77	5.43	≤13	PASS
		20625	846.5	28.64	23.76	4.88	≤13	PASS
	10	20450	829	28.95	23.48	5.47	≤13	PASS
		20525	836.5	28.84	23.43	5.41	≤13	PASS
		20600	844	28.67	23.45	5.22	≤13	PASS
<b>16QAM</b>	1.4	20407	824.7	29.18	22.72	6.46	≤13	PASS
		20525	836.5	28.95	22.70	6.25	≤13	PASS
		20643	848.3	28.22	22.61	5.61	≤13	PASS
	3	20415	825.5	29.17	22.78	6.39	≤13	PASS
		20525	836.5	28.98	22.73	6.25	≤13	PASS



	5	20635	847.5	28.38	22.81	5.57	≤13	PASS
		20425	826.5	29.00	22.68	6.32	≤13	PASS
		20525	836.5	28.96	22.81	6.15	≤13	PASS
		20625	846.5	28.43	22.69	5.74	≤13	PASS
	10	20450	829	28.70	22.44	6.26	≤13	PASS
		20525	836.5	28.62	22.40	6.22	≤13	PASS
		20600	844	28.50	22.42	6.08	≤13	PASS

LTE Band 26								
Modulation	Bandwidth (MHz)	Channel	Frequency (MHz)	Peak (dBm)	Avg (dBm)	PAPR (dB)	Limit (dB)	Conclusion
QPSK	1.4	26797	824.7	28.79	23.40	5.39	≤13	PASS
		26915	836.5	28.83	23.47	5.36	≤13	PASS
		27033	848.3	28.04	23.17	4.87	≤13	PASS
	3	26805	825.5	28.92	23.49	5.43	≤13	PASS
		26915	836.5	28.79	23.54	5.25	≤13	PASS
		27025	847.5	28.11	23.16	4.95	≤13	PASS
	5	26815	826.5	28.91	23.51	5.40	≤13	PASS
		26915	836.5	28.88	23.58	5.30	≤13	PASS
		27015	846.5	28.26	23.33	4.93	≤13	PASS
	10	26840	829	28.81	23.51	5.30	≤13	PASS
		26915	836.5	28.73	23.51	5.22	≤13	PASS
		26990	844	28.46	23.29	5.17	≤13	PASS
15	26865	831.5	29.12	23.40	5.72	≤13	PASS	
	26915	836.5	29.11	23.47	5.64	≤13	PASS	
	26965	841.5	28.92	23.39	5.53	≤13	PASS	
16QAM	1.4	26797	824.7	28.59	22.37	6.22	≤13	PASS
		26915	836.5	28.64	22.53	6.11	≤13	PASS
		27033	848.3	27.89	22.10	5.79	≤13	PASS
	3	26805	825.5	28.66	22.46	6.20	≤13	PASS
		26915	836.5	28.65	22.53	6.12	≤13	PASS
		27025	847.5	27.84	22.10	5.74	≤13	PASS
	5	26815	826.5	28.65	22.53	6.12	≤13	PASS
		26915	836.5	28.62	22.57	6.05	≤13	PASS
		27015	846.5	28.01	22.26	5.75	≤13	PASS
	10	26840	829	28.53	22.46	6.07	≤13	PASS
		26915	836.5	28.57	22.50	6.07	≤13	PASS
		26990	844	28.24	22.23	6.01	≤13	PASS
15	26865	831.5	28.68	22.44	6.24	≤13	PASS	



		26915	836.5	28.64	22.45	6.19	≤13	PASS
		26965	841.5	28.49	22.40	6.09	≤13	PASS



### 5.5. Frequency Stability

#### Ambient condition

Temperature	Relative humidity	Pressure
23°C ~25°C	45%~50%	101.5kPa

#### Method of Measurement

##### Frequency Stability (Temperature Variation)

The temperature inside the climate chamber is varied from 0°C to +35°C in 10°C step size,

(1) With all power removed, the temperature was decreased to 0°C and permitted to stabilize for three hours.

(2) Measure the carrier frequency with the test equipment in a “call mode”. These measurements should be made within 1 minute of powering up the mobile station, to prevent significant self warming.

(3) Repeat the above measurements at 10°C increments from 0°C to +35°C. Allow at least 1.5 hours at each temperature, un-powered, before making measurements.

##### Frequency Stability (Voltage Variation)

The frequency stability shall be measured with variation of primary supply voltage as follows:

**Primary Supply Voltage:** The primary supply voltage is varied from 85% to 115% of the nominal value for non hand-carried battery and AC powered equipment. For hand-carried, battery-powered equipment, primary supply voltage is reduced to the battery operating end point which shall be specified by the manufacturer.

This transceiver is specified to operate with an input voltage of between 3.60 V and 4.45 V, with a nominal voltage of 3.87V.

#### Test setup

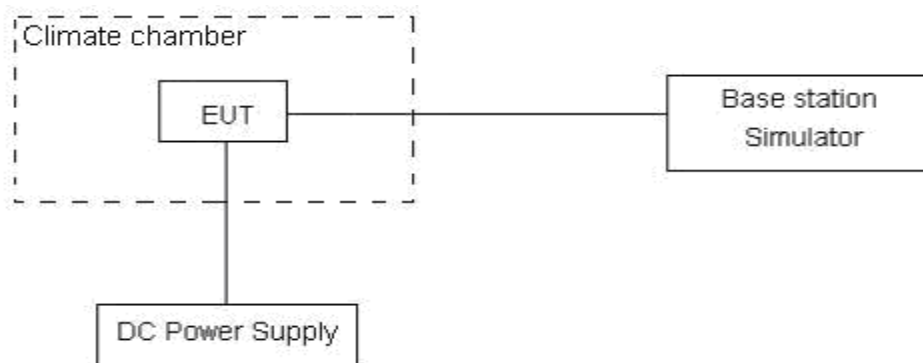

#### Limits

According to the Sec. 22.355, the frequency stability of the carrier shall be accurate to within 2.5 ppm of the received frequency for mobile stations.

Limits	≤ 2.5 ppm
--------	-----------

#### Measurement Uncertainty

The assessed measurement uncertainty to ensure 99.75% confidence level for the normal distribution is with the coverage factor  $k = 3$ ,  $U = 0.01\text{ppm}$ .

**Test Result**

GSM 850						
Condition		Freq.Error (Hz)	Freq.Error (Hz)	Frequency Stability (ppm)	Frequency Stability (ppm)	Verdict
Temperature	Voltage	GMSK	8PSK	GMSK	8PSK	
Normal (25°C)	Normal	1.68	12.10	0.00201	0.01447	PASS
Extreme (35°C)		16.90	13.11	0.02020	0.01567	PASS
Extreme (30°C)		9.23	1.59	0.01103	0.00190	PASS
Extreme (20°C)		1.53	11.38	0.00183	0.01361	PASS
Extreme (10°C)		2.04	9.02	0.00244	0.01078	PASS
Extreme (0°C)		12.04	8.77	0.01439	0.01048	PASS
25°C	LV	10.70	4.03	0.01279	0.00482	PASS
	HV	12.83	17.14	0.01533	0.02048	PASS

WCDMA Band V						
Condition		Freq.Error (Hz)	Freq.Error (Hz)	Frequency Stability (ppm)	Frequency Stability (ppm)	Verdict
Temperature	Voltage	BPSK	QPSK	BPSK	QPSK	
Normal (25°C)	Normal	9.85	1.88	0.01178	0.00224	PASS
Extreme (35°C)		13.75	12.48	0.01644	0.01492	PASS
Extreme (30°C)		7.64	14.59	0.00913	0.01744	PASS
Extreme (20°C)		3.10	3.01	0.00370	0.00360	PASS
Extreme (10°C)		4.35	12.02	0.00520	0.01437	PASS
Extreme (0°C)		16.84	4.26	0.02013	0.00509	PASS
25°C	LV	10.96	11.33	0.01310	0.01354	PASS
	HV	6.32	17.26	0.00756	0.02064	PASS

LTE Band 5						
Condition		Freq.Error (Hz)	Freq.Error (Hz)	Frequency Stability (ppm)	Frequency Stability (ppm)	Verdict
BANDWIDTH	1.4MHz	16QAM	QPSK	16QAM	QPSK	
Normal (25°C)	Normal	17.32	9.07	0.02070	0.01084	PASS
Extreme (35°C)		10.62	2.75	0.01269	0.00329	PASS
Extreme (30°C)		3.69	14.15	0.00441	0.01691	PASS
Extreme (20°C)		17.59	14.90	0.02102	0.01781	PASS
Extreme (10°C)		1.43	8.83	0.00171	0.01055	PASS
Extreme (0°C)		12.17	16.60	0.01455	0.01984	PASS



25°C	LV	6.58	9.76	0.00787	0.01167	PASS
	HV	4.37	7.39	0.00523	0.00883	PASS
Condition		Freq.Error (Hz)	Freq.Error (Hz)	Frequency Stability (ppm)	Frequency Stability (ppm)	Verdict
BANDWIDTH	3MHz					
Temperature	Voltage	16QAM	QPSK	16QAM	QPSK	
Normal (25°C)	Normal	15.11	10.29	0.01806	0.01230	PASS
Extreme (35°C)		3.14	6.23	0.00376	0.00745	PASS
Extreme (30°C)		7.71	4.33	0.00922	0.00517	PASS
Extreme (20°C)		6.73	16.37	0.00805	0.01957	PASS
Extreme (10°C)		2.41	1.21	0.00288	0.00145	PASS
Extreme (0°C)		15.47	12.44	0.01850	0.01487	PASS
25°C	LV	13.08	11.89	0.01564	0.01422	PASS
	HV	1.28	12.21	0.00153	0.01459	PASS
Condition		Freq.Error (Hz)	Freq.Error (Hz)	Frequency Stability (ppm)	Frequency Stability (ppm)	Verdict
BANDWIDTH	5MHz					
Temperature	Voltage	16QAM	QPSK	16QAM	QPSK	
Normal (25°C)	Normal	12.83	4.43	0.01533	0.00529	PASS
Extreme (35°C)		13.58	15.76	0.01623	0.01884	PASS
Extreme (30°C)		7.80	2.88	0.00933	0.00344	PASS
Extreme (20°C)		12.30	13.46	0.01471	0.01610	PASS
Extreme (10°C)		9.10	15.88	0.01088	0.01898	PASS
Extreme (0°C)		14.40	3.75	0.01721	0.00448	PASS
25°C	LV	7.25	1.49	0.00867	0.00179	PASS
	HV	1.39	14.03	0.00166	0.01677	PASS
Condition		Freq.Error (Hz)	Freq.Error (Hz)	Frequency Stability (ppm)	Frequency Stability (ppm)	Verdict
BANDWIDTH	10MHz					
Temperature	Voltage	16QAM	QPSK	16QAM	QPSK	
Normal (25°C)	Normal	1.21	17.16	0.00145	0.02051	PASS
Extreme (35°C)		3.51	6.21	0.00420	0.00743	PASS
Extreme (30°C)		8.73	4.14	0.01043	0.00495	PASS
Extreme (20°C)		13.16	16.15	0.01574	0.01931	PASS
Extreme (10°C)		4.45	14.20	0.00532	0.01698	PASS
Extreme (0°C)		5.37	1.43	0.00642	0.00171	PASS
25°C	LV	6.26	15.21	0.00748	0.01818	PASS
	HV	17.84	6.63	0.02132	0.00792	PASS

LTE Band 26						
Condition		Freq.Error (Hz)	Freq.Error (Hz)	Frequency Stability (ppm)	Frequency Stability (ppm)	Verdict
BANDWIDTH	1.4MHz					
Temperature	Voltage	16QAM	QPSK	16QAM	QPSK	
Normal (25°C)	Normal	6.60	2.99	0.00789	0.00358	PASS
Extreme (35°C)		12.38	16.89	0.01480	0.02019	PASS
Extreme (30°C)		14.08	17.27	0.01683	0.02065	PASS
Extreme (20°C)		6.19	5.73	0.00741	0.00684	PASS
Extreme (10°C)		1.53	1.89	0.00183	0.00226	PASS
Extreme (0°C)		17.26	13.89	0.02064	0.01661	PASS
25°C		LV	6.47	3.54	0.00774	0.00423
	HV	2.70	3.27	0.00323	0.00390	PASS
Condition		Freq.Error (Hz)	Freq.Error (Hz)	Frequency Stability (ppm)	Frequency Stability (ppm)	Verdict
BANDWIDTH	3MHz					
Temperature	Voltage	16QAM	QPSK	16QAM	QPSK	
Normal (25°C)	Normal	8.14	17.14	0.00973	0.02049	PASS
Extreme (35°C)		1.51	6.65	0.00180	0.00795	PASS
Extreme (30°C)		1.91	2.70	0.00228	0.00323	PASS
Extreme (20°C)		1.09	4.10	0.00130	0.00490	PASS
Extreme (10°C)		12.89	15.18	0.01541	0.01814	PASS
Extreme (0°C)		1.45	13.32	0.00174	0.01592	PASS
25°C		LV	16.16	9.35	0.01932	0.01117
	HV	11.29	12.58	0.01349	0.01504	PASS
Condition		Freq.Error (Hz)	Freq.Error (Hz)	Frequency Stability (ppm)	Frequency Stability (ppm)	Verdict
BANDWIDTH	5MHz					
Temperature	Voltage	16QAM	QPSK	16QAM	QPSK	
Normal (25°C)	Normal	5.84	1.47	0.00699	0.00175	PASS
Extreme (35°C)		13.23	1.80	0.01582	0.00215	PASS
Extreme (30°C)		14.42	15.95	0.01724	0.01907	PASS
Extreme (20°C)		14.73	5.64	0.01761	0.00675	PASS
Extreme (10°C)		6.31	6.71	0.00754	0.00802	PASS
Extreme (0°C)		6.54	2.72	0.00782	0.00325	PASS
25°C		LV	7.72	7.18	0.00923	0.00858
	HV	2.69	7.57	0.00322	0.00905	PASS
Condition		Freq.Error (Hz)	Freq.Error (Hz)	Frequency Stability (ppm)	Frequency Stability (ppm)	Verdict
BANDWIDTH	10MHz					
Temperature	Voltage	16QAM	QPSK	16QAM	QPSK	
Normal (25°C)	Normal	5.71	12.70	0.00683	0.01518	PASS



Extreme (35°C)		13.24	3.58	0.01582	0.00428	PASS
Extreme (30°C)		2.78	11.13	0.00333	0.01330	PASS
Extreme (20°C)		1.40	15.37	0.00167	0.01838	PASS
Extreme (10°C)		11.80	11.28	0.01411	0.01348	PASS
Extreme (0°C)		15.63	4.76	0.01869	0.00569	PASS
25°C	LV	10.34	17.33	0.01236	0.02072	PASS
	HV	1.40	2.80	0.00167	0.00334	PASS
Condition		Freq.Error (Hz)	Freq.Error (Hz)	Frequency Stability (ppm)	Frequency Stability (ppm)	Verdict
BANDWIDTH	15MHz					
Temperature	Voltage	16QAM	QPSK	16QAM	QPSK	
Normal (25°C)	Normal	10.40	16.63	0.01243	0.01987	PASS
Extreme (35°C)		4.00	3.99	0.00478	0.00478	PASS
Extreme (30°C)		2.47	8.17	0.00295	0.00976	PASS
Extreme (20°C)		16.93	14.90	0.02024	0.01782	PASS
Extreme (10°C)		7.55	4.87	0.00903	0.00583	PASS
Extreme (0°C)		1.08	16.36	0.00130	0.01956	PASS
25°C	LV	13.15	16.08	0.01572	0.01922	PASS
	HV	6.96	17.71	0.00832	0.02117	PASS

### 5.6. Spurious Emissions at Antenna Terminals

#### Ambient condition

Temperature	Relative humidity	Pressure
23°C ~25°C	45%~50%	101.5kPa

#### Method of Measurement

The EUT was connected to Spectrum Analyzer and Base Station Simulator via power Splitter. The measurement is carried out using a spectrum analyzer. The spectrum analyzer scans from 9kHz to the 10th harmonic of the carrier.

The peak detector is used. RBW are set to 100 kHz and VBW are set to 300 kHz for below 1G, RBW are set to 1MHz and VBW are set to 3MHz for above 1G, Sweep is set to ATUO.

RBW is set to 1 kHz (0.009MHz~ 0.15 MHz),

RBW is set to 10 kHz (0.15 MHz~ 30 MHz)

RBW is set to 100 kHz (30MHz~1000 MHz)

RBW is set to 1000 kHz (above 1000MHz)

The modulation mode and RB allocation refer to section 5.1, using the maximum output power configuration.

#### Test setup

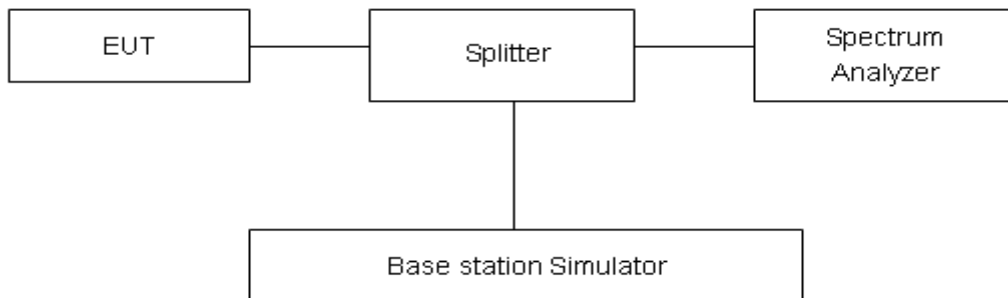

#### Limits

Rule Part 22.917(a) specifies that “The power of any emission outside of the authorized operating frequency ranges must be attenuated below the transmitting power (P) by a factor of at least 43 + 10 log (P) dB.”

Limit	-13 dBm

#### Measurement Uncertainty

The assessed measurement uncertainty to ensure 99.75% confidence level for the normal distribution is with the coverage factor  $k = 1.96$ .

Frequency	Uncertainty
9kHz-1GHz	0.684 dB
1GHz-20GHz	1.407 dB

Test Result

Sweep the whole frequency band through the range from 9kHz to the 10th harmonic of the carrier, the emissions more than 20 dB below the limit are not reported.

The signal beyond the limit is carrier.

GSM 850 CH-Low 9kHz ~ 20GHz

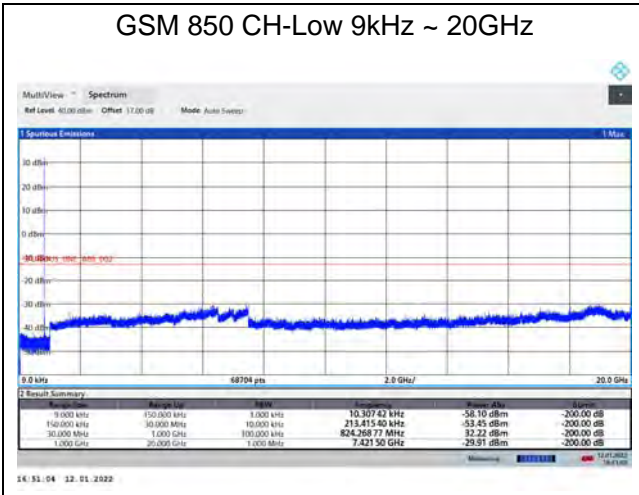

GPRS 850 CH-Low 9kHz ~ 20GHz

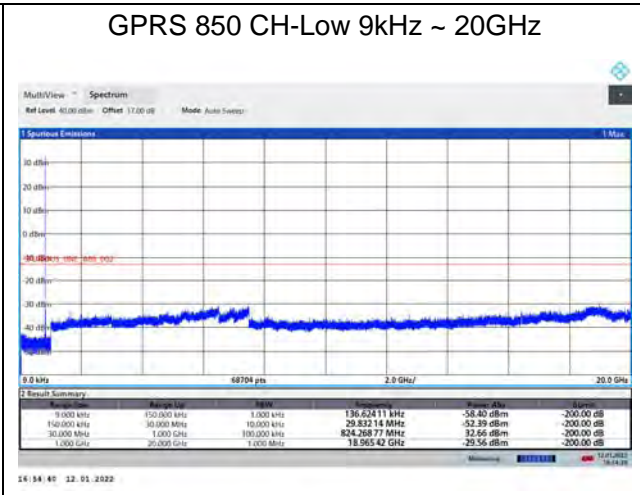

GSM 850 CH-Middle 9kHz ~ 20GHz

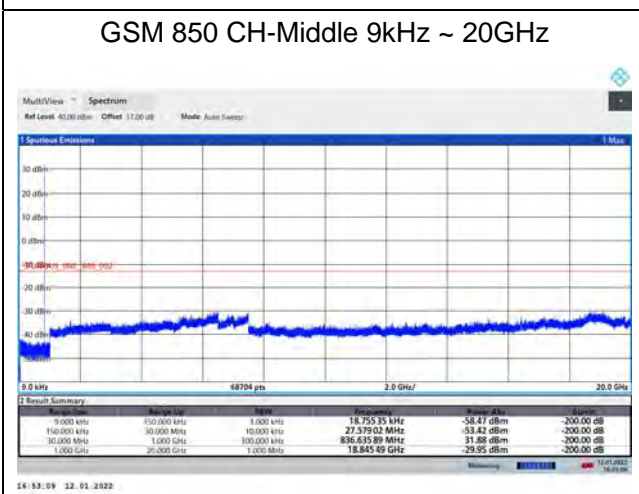

GPRS 850 CH-Middle 9kHz ~ 20GHz

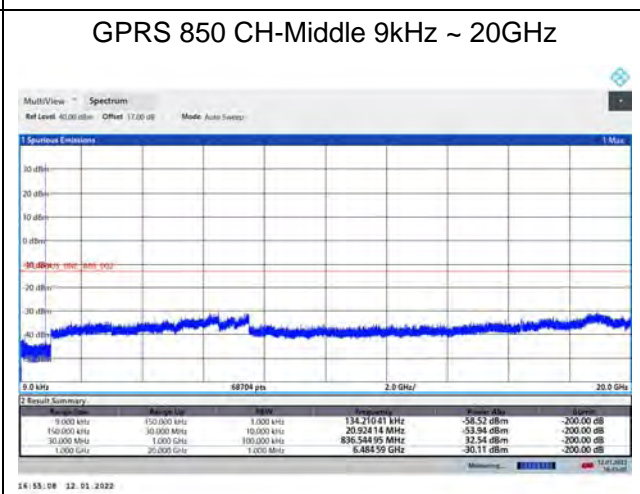

GSM 850 CH-High 9kHz ~ 20GHz

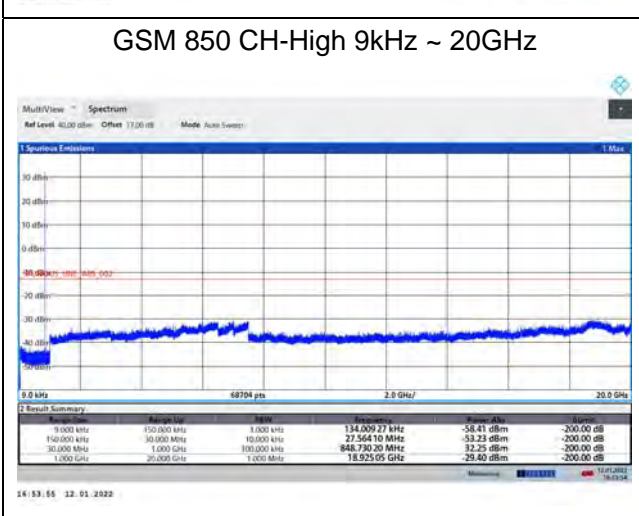

GPRS 850 CH-High 9kHz ~ 20GHz

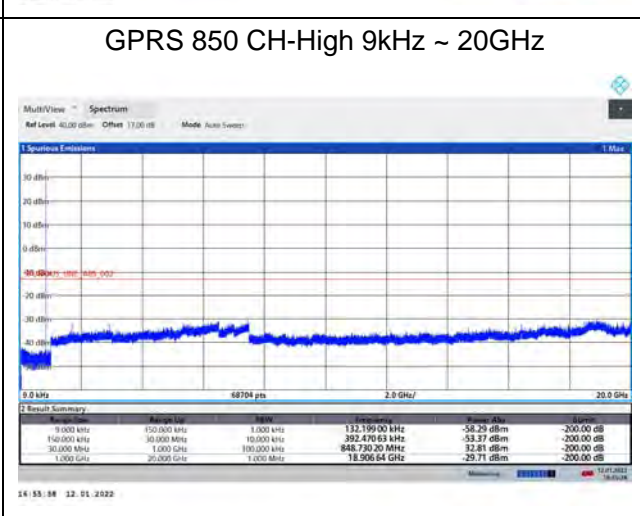



### EGPRS 850 CH-Low 9kHz ~ 20GHz

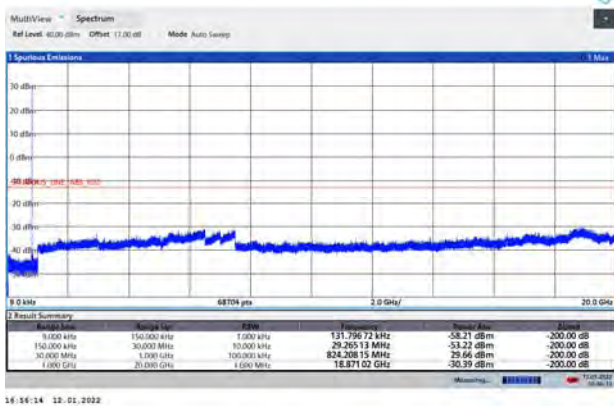

16:56:14 12.01.2022

### WCDMA BAND V CH-Low 9kHz ~ 20GHz

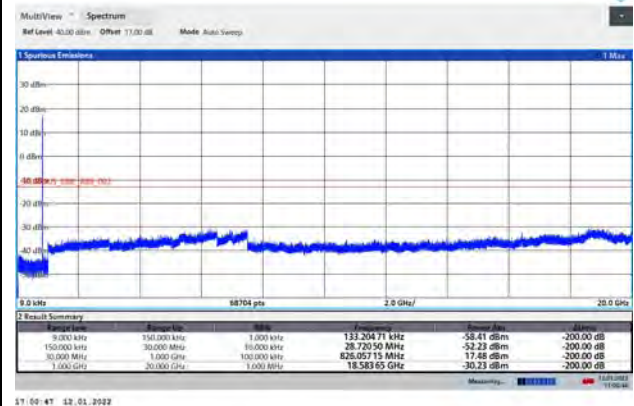

17:00:47 12.01.2022

### EGPRS 850 CH-Middle 9kHz ~ 20GHz

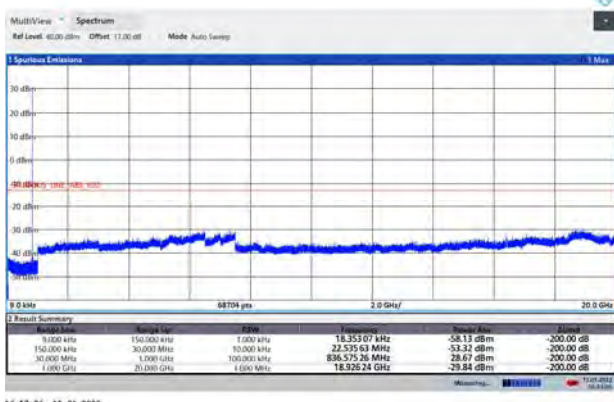

16:57:04 12.01.2022

### WCDMA BAND V CH-Middle 9kHz ~ 20GHz

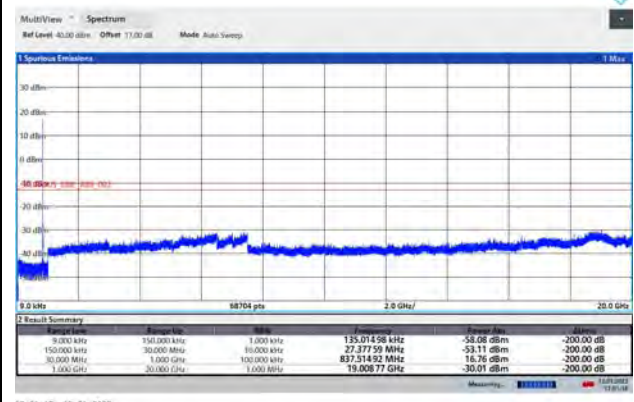

17:01:17 12.01.2022

### EGPRS 850 CH-High 9kHz ~ 20GHz

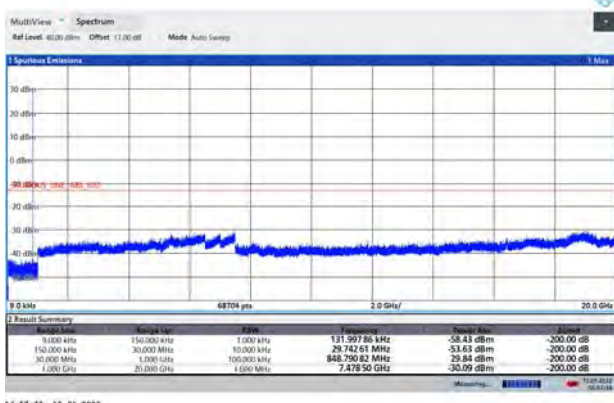

16:57:38 12.01.2022

### WCDMA BAND V CH-High 9kHz ~ 20GHz

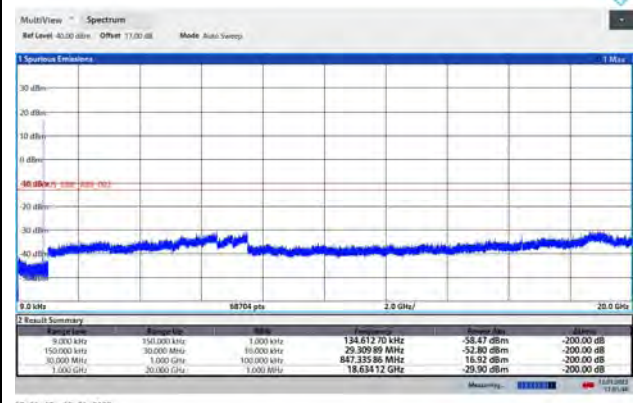

17:01:47 12.01.2022





LTE Band 5 1.4MHz CH-Low 9kHz~10GHz

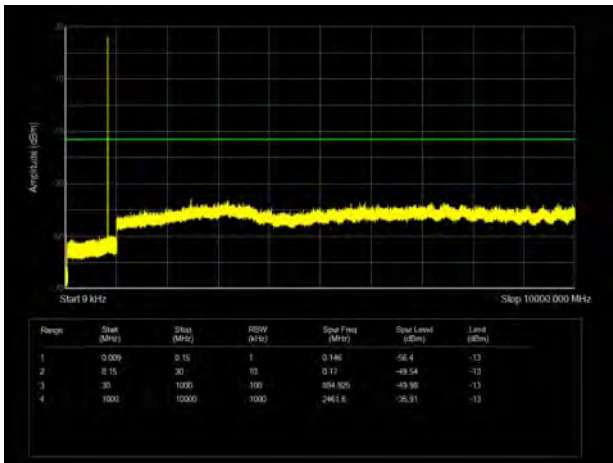

LTE Band 5 3MHz CH-Low 9kHz~10GHz

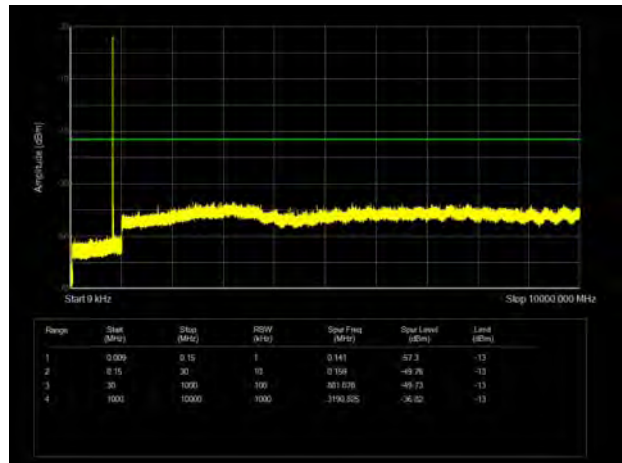

LTE Band 5 1.4MHz CH-Middle 9kHz~10GHz

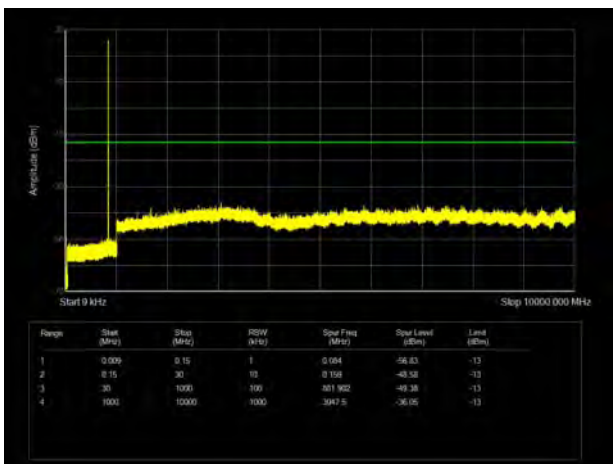

LTE Band 5 3MHz CH-Middle 9kHz~10GHz

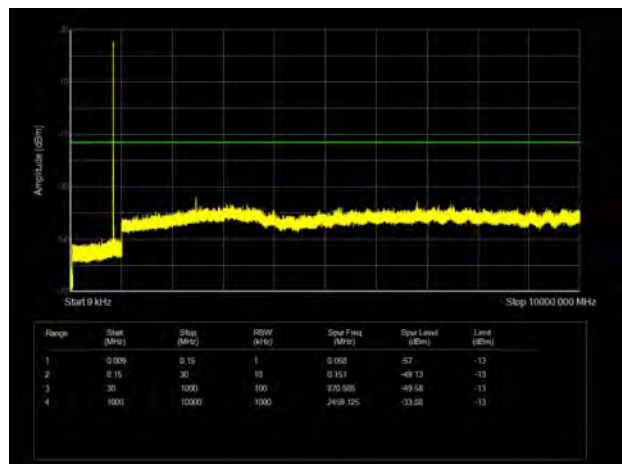

LTE Band 5 1.4MHz CH-High 9kHz~10GHz

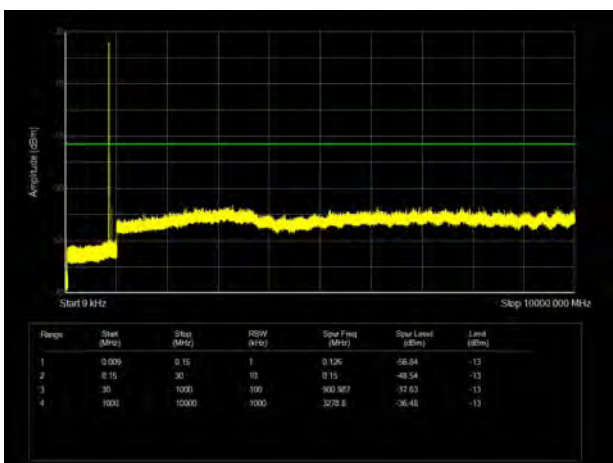

LTE Band 5 3MHz CH-High 9kHz~10GHz

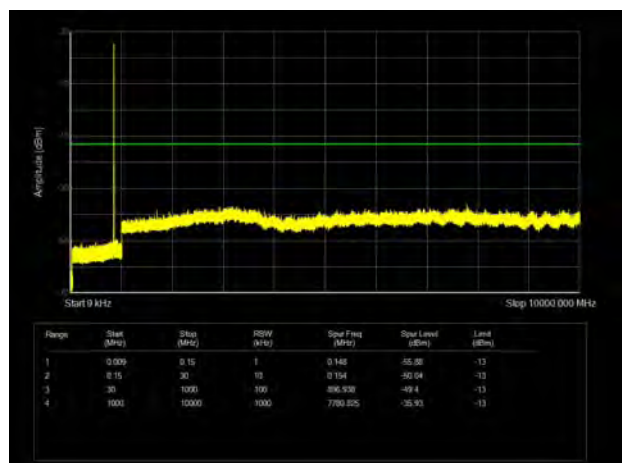



LTE Band 5 5MHz CH-Low 9kHz~10GHz

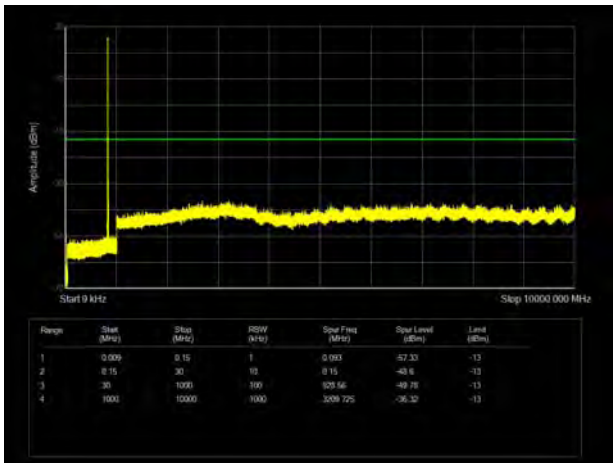

LTE Band 5 10MHz CH-Low 9kHz~10GHz

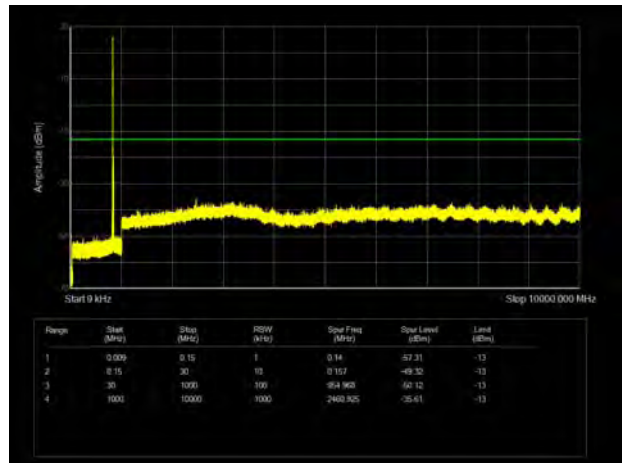

LTE Band 5 5MHz CH-Middle 9kHz~10GHz

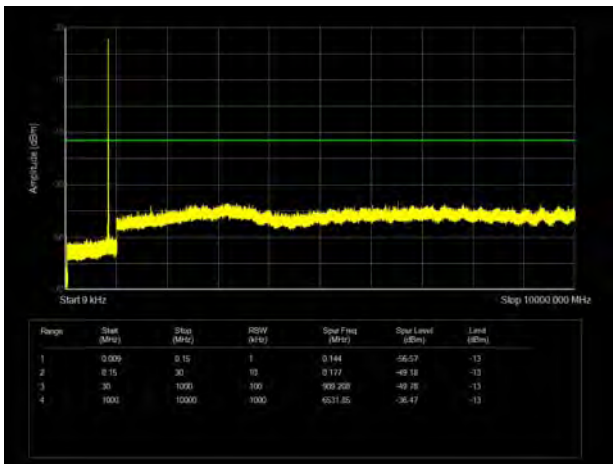

LTE Band 5 10MHz CH-Middle 9kHz~10GHz

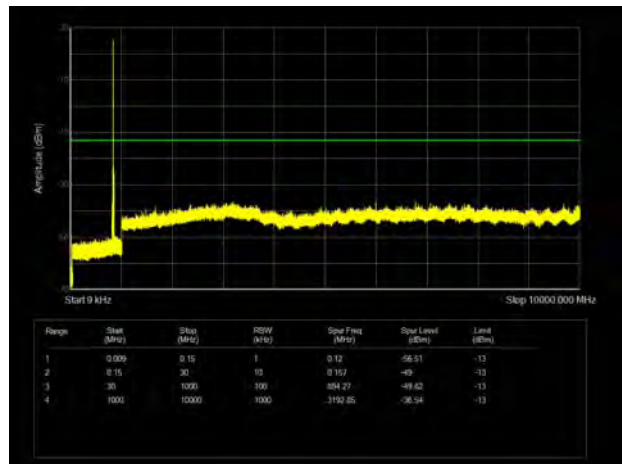

LTE Band 5 5MHz CH-High 9kHz~10GHz

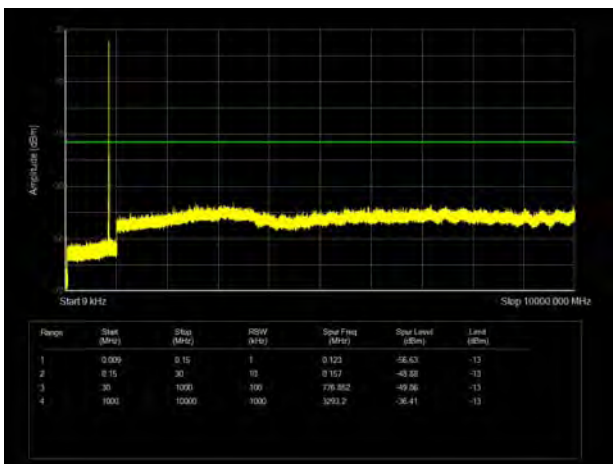

LTE Band 5 10MHz CH-High 9kHz~10GHz

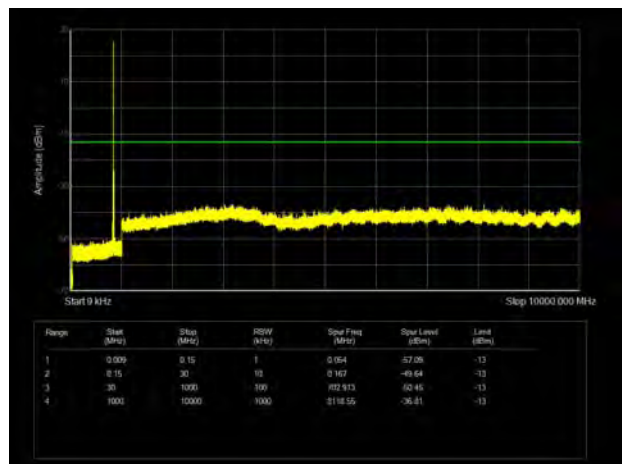

LTE Band 26 1.4MHz CH-Low 9kHz~10GHz

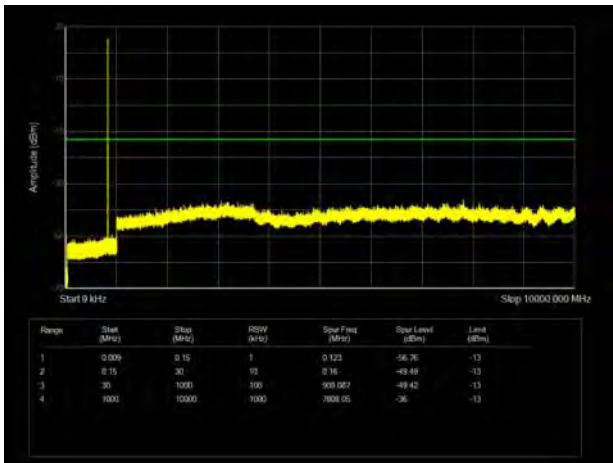

LTE Band 26 3MHz CH-Low 9kHz~10GHz

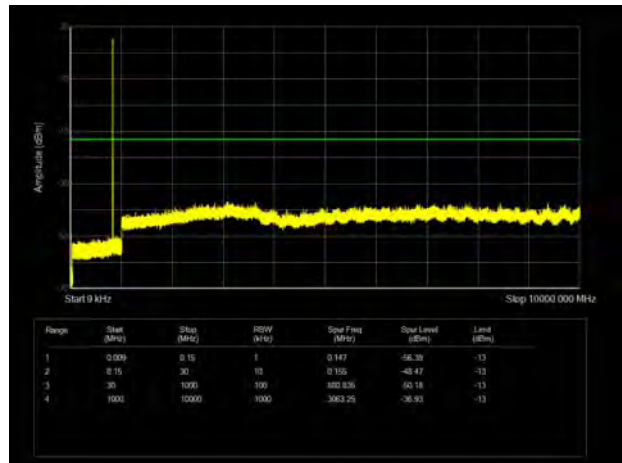

LTE Band 26 1.4MHz CH-Middle 9kHz~10GHz

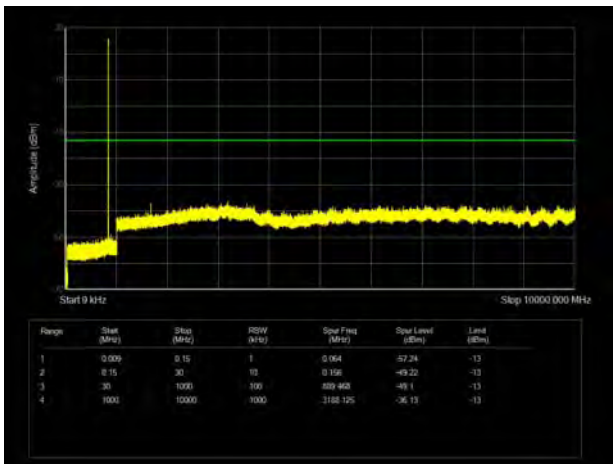

LTE Band 26 3MHz CH-Middle 9kHz~10GHz

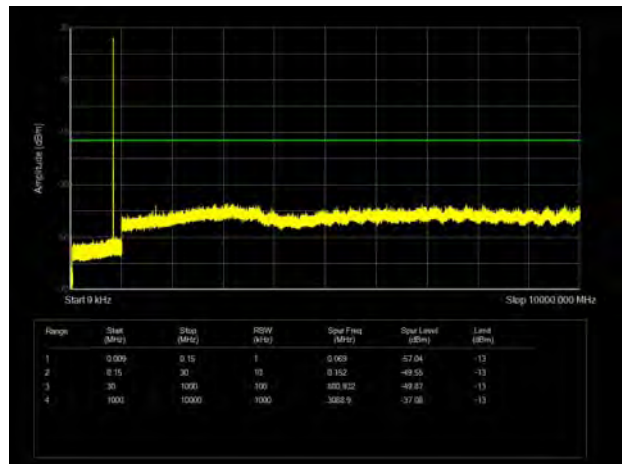

LTE Band 26 1.4MHz CH-High 9kHz~10GHz

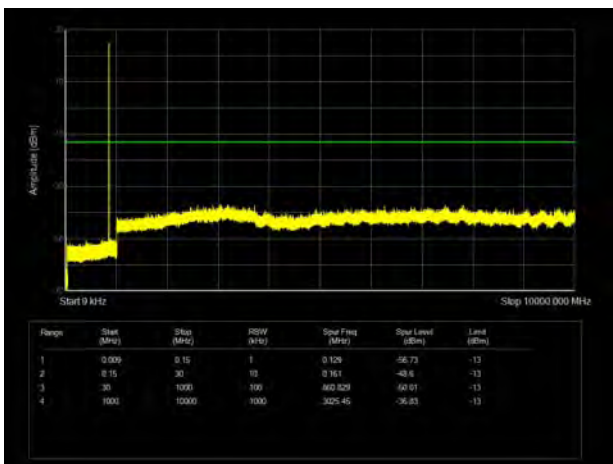

LTE Band 26 3MHz CH-High 9kHz~10GHz

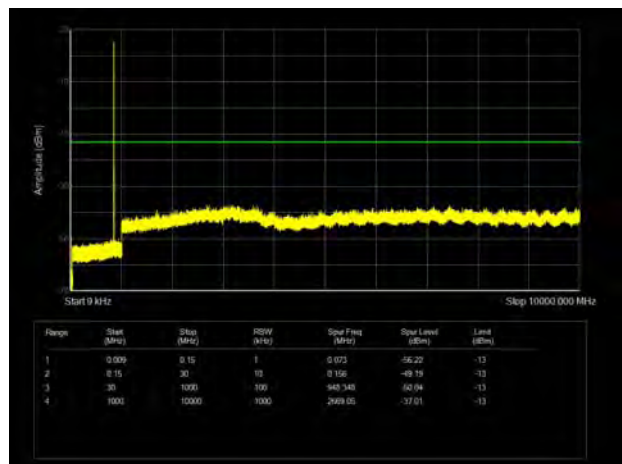

LTE Band 26 5MHz CH-Low 9kHz~10GHz

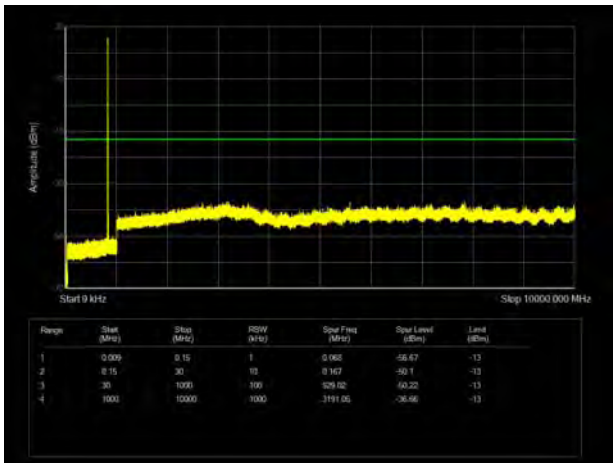

LTE Band 26 10MHz CH-Low 9kHz~10GHz

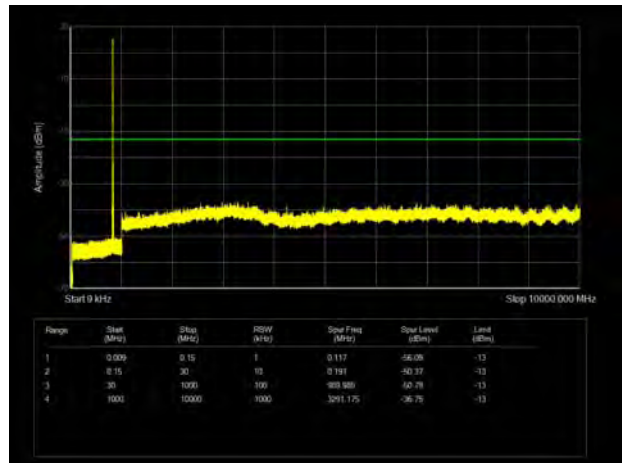

LTE Band 26 5MHz CH-Middle 9kHz~10GHz

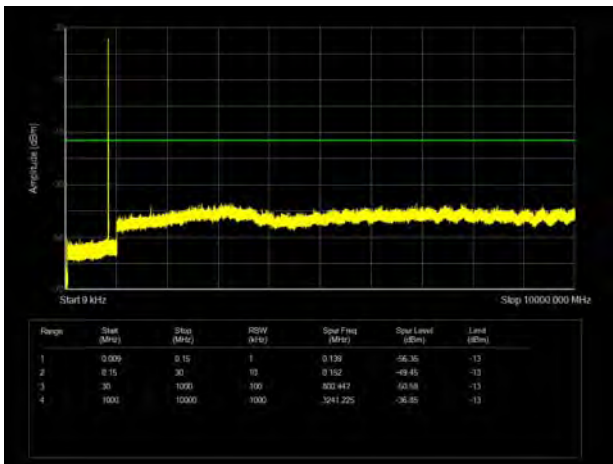

LTE Band 26 10MHz CH-Middle 9kHz~10GHz

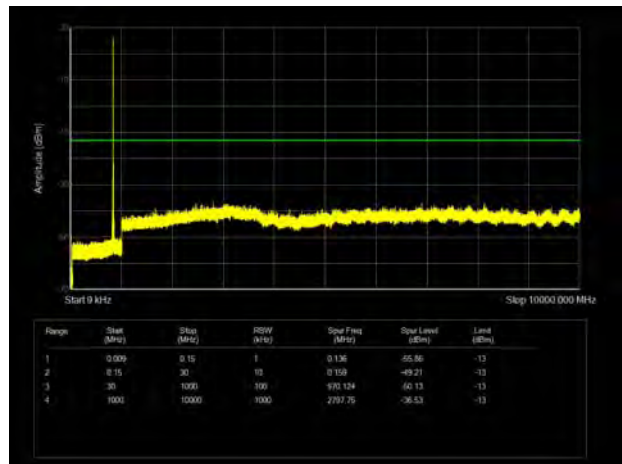

LTE Band 26 5MHz CH-High 9kHz~10GHz

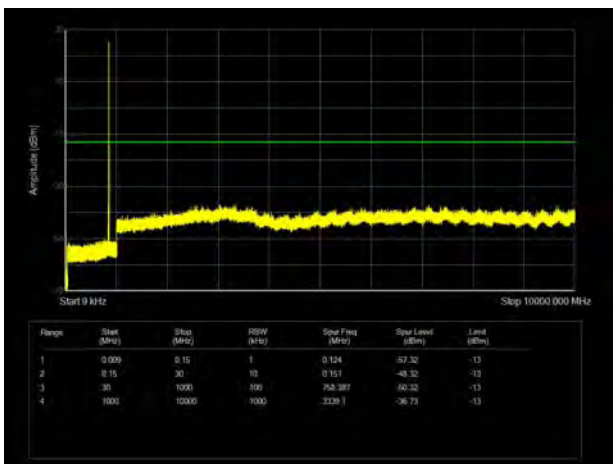

LTE Band 26 10MHz CH-High 9kHz~10GHz

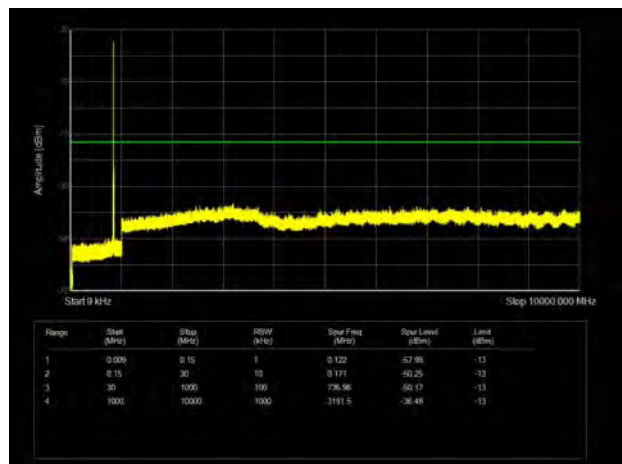

LTE Band 26 15MHz CH-Low 9kHz~10GHz

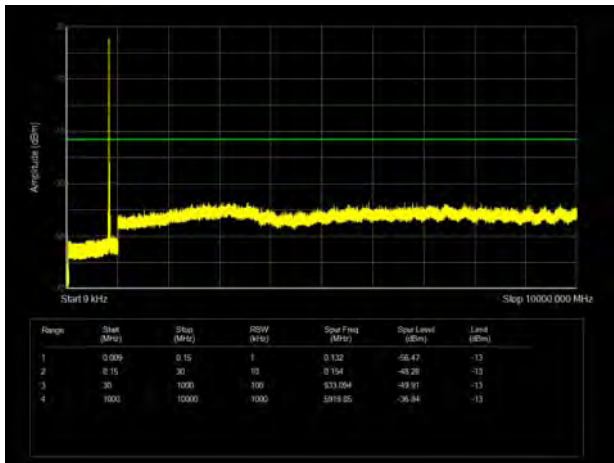

LTE Band 26 15MHz CH-Middle 9kHz~10GHz

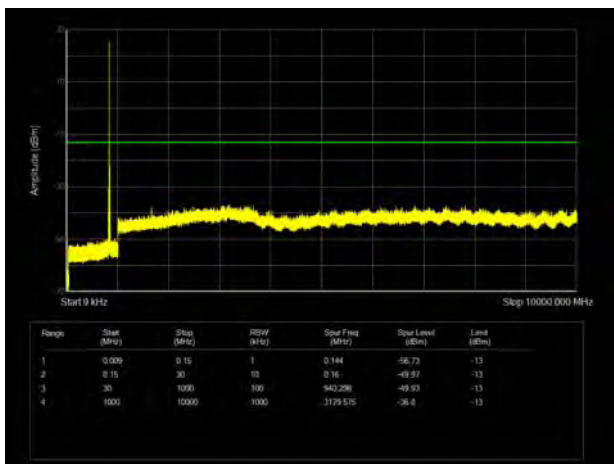

LTE Band 26 15MHz CH-High 9kHz~10GHz

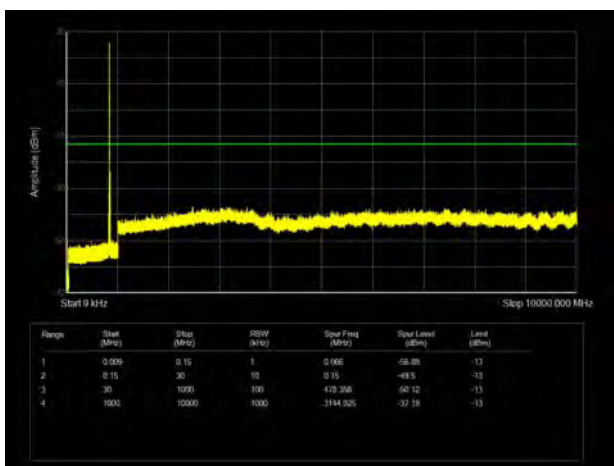

## 5.7. Radiates Spurious Emission

### Ambient condition

Temperature	Relative humidity	Pressure
23°C ~25°C	45%~50%	101.5kPa

### Method of Measurement

1. The testing follows FCC KDB 971168 v03r01 Section 5.8 and ANSI C63.26 (2015).
2. Below 1GHz: The EUT is placed on a turntable 0.8 meters above the ground in the chamber, 3 meter away from the antenna. The maximal emission value is acquired by adjusting the antenna height, polarisation and turntable azimuth. Normally, the height range of antenna is 1 m to 4 m, the azimuth range of turntable is 0° to 360°, and the receive antenna has two polarizations Vertical (V) and Horizontal (H). Above 1GHz: (Note: the FCC's permission to use 1.5m as an alternative per TCBC Conf call of Dec. 2, 2014.) The EUT is placed on a turntable 1.5 meters above the ground in the chamber, 3 meter away from the antenna. The maximal emission value is acquired by adjusting the antenna height, polarisation and turntable azimuth. Normally, the height range of antenna is 1 m to 4 m, the azimuth range of turntable is 0° to 360°, and the receive antenna has two polarizations Vertical (V) and Horizontal (H).
3. A loop antenna, A log-periodic antenna or horn antenna shall be substituted in place of the EUT. The log-periodic antenna will be driven by a signal generator and the level will be adjusted till the same power value on the spectrum analyzer or receiver. The level of the spurious emissions can be calculated through the level of the signal generator, cable loss, the gain of the substitution antenna and the reading of the spectrum analyzer or receiver.
4. The EUT is then put into continuously transmitting mode at its maximum power level during the test. Set Test Receiver or Spectrum RBW=100kHz, VBW=300kHz for 30MHz to 1GHz and RBW=1MHz, VBW=3MHz for above 1GHz, and the maximum value of the receiver should be recorded as (Pr).
5. The EUT shall be replaced by a substitution antenna. In the chamber, an substitution antenna for the frequency band of interest is placed at the reference point of the chamber. An RF Signal source for the frequency band of interest is connected to the substitution antenna with a cable that has been constructed to not interfere with the radiation pattern of the antenna. A power (PMea) is applied to the input of the substitution antenna, and adjust the level of the signal generator output until the value of the receiver reach the previously recorded (Pr). The power of signal source (PMea) is recorded. The test should be performed by rotating the test item and adjusting the receiving antenna polarization.
6. A amplifier should be connected to the Signal Source output port. And the cable should be connect between the Amplifier and the Substitution Antenna. The cable loss (Pcl) ,the Substitution Antenna Gain (Ga) and the Amplifier Gain (PAg) should be recorded after test.
7. The measurement results are obtained as described below:  

$$\text{Power(EIRP)} = \text{PMea} - \text{PAg} - \text{Pcl} + \text{Ga}$$
 The measurement results are amend as described below:  

$$\text{Power(EIRP)} = \text{PMea} - \text{Pcl} + \text{Ga}$$
8. This value is EIRP since the measurement is calibrated using an antenna of known gain (2.15 dB) and known input power. ERP can be calculated from EIRP by subtracting the gain of the dipole, ERP

= EIRP-2.15dB.

The modulation mode and RB allocation refer to section 5.1, using the maximum output power configuration.

**Test setup**

**9KHz ~ 30MHz**

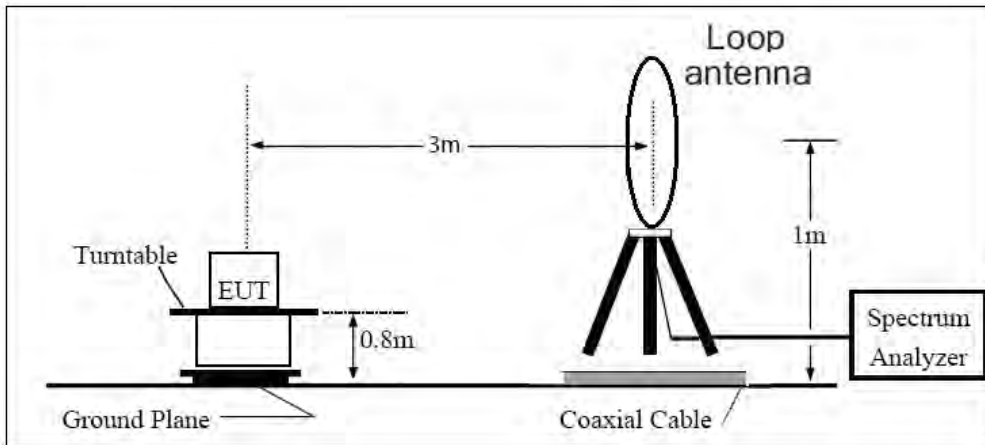

**30MHz ~ 1GHz**

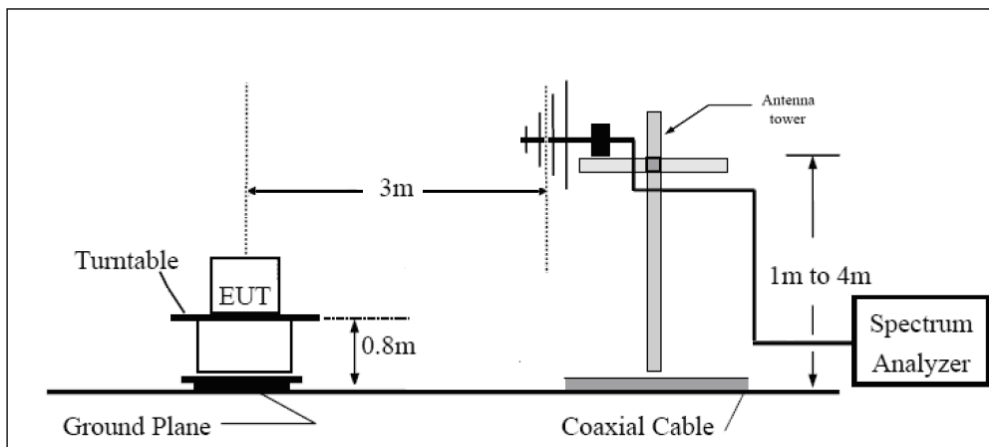

**Above 1GHz**

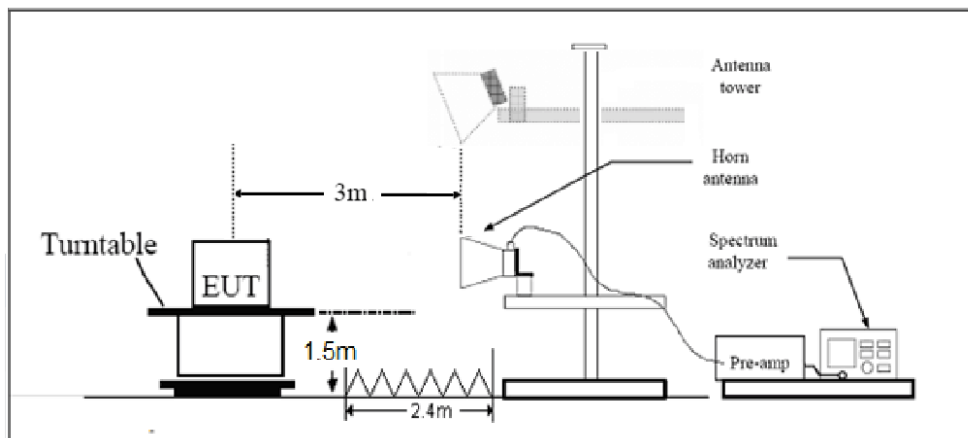

Note: Area side:2.4mX3.6m

## Limits

Rule Part 22.917(a) specifies that “The power of any emission outside of the authorized operating frequency ranges must be attenuated below the transmitting power (P) by a factor of at least  $43 + 10 \log (P)$  dB.”

Limit	-13 dBm
-------	---------

## Measurement Uncertainty

The assessed measurement uncertainty to ensure 95% confidence level for the normal distribution is with the coverage factor  $k = 1.96$ ,  $U = 3.55$  dB.



**Test Result**

Sweep the whole frequency band through the range from 9kHz to the 10th harmonic of the carrier, the emissions below the noise floor will not be recorded in the report.

**Main Antenna**

GSM 850 CH-Middle

Harmonic	Frequency (MHz)	SG (dBm)	Cable Loss (dB)	Gain (dBi)	Antenna Polarization	ERP Level (dBm)	Limit (dBm)	Margin (dB)	Azimuth (deg)
2	1672.50	-67.80	1.70	8.70	Horizontal	-62.95	-13.00	49.95	0
3	2509.90	-61.34	2.30	12.00	Horizontal	-53.79	-13.00	40.79	45
4	3346.40	-65.78	2.70	12.70	Horizontal	-57.93	-13.00	44.93	180
5	4183.00	-63.04	3.00	12.50	Horizontal	-55.69	-13.00	42.69	90
6	5019.60	-59.37	3.40	12.50	Horizontal	-52.42	-13.00	39.42	315
7	5856.20	-60.70	3.40	12.80	Horizontal	-53.45	-13.00	40.45	225
8	6692.80	-57.18	4.10	11.50	Horizontal	-51.93	-13.00	38.93	90
9	7529.40	-54.65	4.20	12.20	Horizontal	-48.80	-13.00	35.80	135
10	8366.00	-55.60	4.30	12.50	Horizontal	-49.55	-13.00	36.55	315

Note: 1.The other Spurious RF Radiated emissions level is no more than noise floor.

2.The worst emission was found in the antenna is Horizontal position.

**WCDMA Band V CH-Middle**

Harmonic	Frequency (MHz)	SG (dBm)	Cable Loss (dB)	Gain (dBi)	Antenna Polarization	ERP Level (dBm)	Limit (dBm)	Margin (dB)	Azimuth (deg)
2	1673.20	-69.69	1.70	8.70	Horizontal	-64.84	-13.00	51.84	45
3	2509.80	-66.89	2.30	12.00	Horizontal	-59.34	-13.00	46.34	225
4	3346.40	-65.87	2.70	12.70	Horizontal	-58.02	-13.00	45.02	0
5	4183.00	-62.42	3.00	12.50	Horizontal	-55.07	-13.00	42.07	270
6	5019.60	-60.40	3.40	12.50	Horizontal	-53.45	-13.00	40.45	135
7	5856.20	-60.58	3.40	12.80	Horizontal	-53.33	-13.00	40.33	270
8	6692.80	-57.19	4.10	11.50	Horizontal	-51.94	-13.00	38.94	45
9	7529.40	-54.97	4.20	12.20	Horizontal	-49.12	-13.00	36.12	315
10	8366.00	-55.61	4.30	12.50	Horizontal	-49.56	-13.00	36.56	270

Note: 1.The other Spurious RF Radiated emissions level is no more than noise floor.

2.The worst emission was found in the antenna is Horizontal position.



## LTE Band 5 1.4MHz CH-Middle

Harmonic	Frequency (MHz)	SG (dBm)	Cable Loss (dB)	Gain (dBi)	Antenna Polarization	ERP Level (dBm)	Limit (dBm)	Margin (dB)	Azimuth (deg)
2	1673.00	-64.83	1.70	8.70	Horizontal	-59.98	-13.00	46.98	225
3	2509.50	-63.83	2.30	12.00	Horizontal	-56.28	-13.00	43.28	45
4	3346.00	-66.01	2.70	12.70	Horizontal	-58.16	-13.00	45.16	90
5	4182.50	-61.86	3.00	12.50	Horizontal	-54.51	-13.00	41.51	180
6	5019.00	-59.75	3.40	12.50	Horizontal	-52.80	-13.00	39.80	270
7	5855.50	-58.81	3.40	12.80	Horizontal	-51.56	-13.00	38.56	270
8	6692.00	-57.83	4.10	11.50	Horizontal	-52.58	-13.00	39.58	270
9	7528.50	-55.85	4.20	12.20	Horizontal	-50.00	-13.00	37.00	45
10	8365.00	-56.00	4.30	12.50	Horizontal	-49.95	-13.00	36.95	135

Note: 1.The other Spurious RF Radiated emissions level is no more than noise floor.  
2.The worst emission was found in the antenna is Horizontal position.

## LTE Band 5 5MHz CH-Middle

Harmonic	Frequency (MHz)	SG (dBm)	Cable Loss (dB)	Gain (dBi)	Antenna Polarization	ERP Level (dBm)	Limit (dBm)	Margin (dB)	Azimuth (deg)
2	1668.60	-65.40	1.70	8.70	Horizontal	-60.55	-13.00	47.55	135
3	2503.30	-64.43	2.30	12.00	Horizontal	-56.88	-13.00	43.88	90
4	3466.20	-65.21	2.70	12.70	Horizontal	-57.36	-13.00	44.36	0
5	4215.90	-63.54	3.00	12.50	Horizontal	-56.19	-13.00	43.19	135
6	5165.60	-57.85	3.40	12.50	Horizontal	-50.90	-13.00	37.90	0
7	5815.30	-58.89	3.40	12.80	Horizontal	-51.64	-13.00	38.64	315
8	6765.00	-59.05	4.10	11.50	Horizontal	-53.80	-13.00	40.80	0
9	7614.70	-56.55	4.20	12.20	Horizontal	-50.70	-13.00	37.70	0
10	8464.40	-56.14	4.30	12.50	Horizontal	-50.09	-13.00	37.09	180

Note: 1.The other Spurious RF Radiated emissions level is no more than noise floor.  
2.The worst emission was found in the antenna is Horizontal position.

**LTE Band 5 10MHz CH-Middle**

Harmonic	Frequency (MHz)	SG (dBm)	Cable Loss (dB)	Gain (dBi)	Antenna Polarization	ERP Level (dBm)	Limit (dBm)	Margin (dB)	Azimuth (deg)
2	1664.40	-65.53	1.70	8.70	Horizontal	-60.68	-13.00	47.68	225
3	2496.60	-65.21	2.30	12.00	Horizontal	-57.66	-13.00	44.66	90
4	3346.00	-65.68	2.70	12.70	Horizontal	-57.83	-13.00	44.83	135
5	4182.50	-62.24	3.00	12.50	Horizontal	-54.89	-13.00	41.89	315
6	5019.00	-58.23	3.40	12.50	Horizontal	-51.28	-13.00	38.28	0
7	5855.50	-58.45	3.40	12.80	Horizontal	-51.20	-13.00	38.20	180
8	6692.00	-57.51	4.10	11.50	Horizontal	-52.26	-13.00	39.26	270
9	7528.50	-55.85	4.20	12.20	Horizontal	-50.00	-13.00	37.00	135
10	8365.00	-55.82	4.30	12.50	Horizontal	-49.77	-13.00	36.77	180

Note: 1.The other Spurious RF Radiated emissions level is no more than noise floor.  
 2.The worst emission was found in the antenna is Horizontal position.

**LTE Band 26 1.4MHz CH-Middle**

Harmonic	Frequency (MHz)	SG (dBm)	Cable Loss (dB)	Gain (dBi)	Antenna Polarization	ERP Level (dBm)	Limit (dBm)	Margin (dB)	Azimuth (deg)
2	1672.13	-65.40	1.70	8.70	Horizontal	-60.55	-13.00	47.55	225
3	2508.00	-64.09	2.30	12.00	Horizontal	-56.54	-13.00	43.54	45
4	3346.00	-66.24	2.70	12.70	Horizontal	-58.39	-13.00	45.39	180
5	4182.50	-63.43	3.00	12.50	Horizontal	-56.08	-13.00	43.08	90
6	5019.00	-59.85	3.40	12.50	Horizontal	-52.90	-13.00	39.90	135
7	5855.50	-59.72	3.40	12.80	Horizontal	-52.47	-13.00	39.47	180
8	6692.00	-59.30	4.10	11.50	Horizontal	-54.05	-13.00	41.05	90
9	7528.50	-55.09	4.20	12.20	Horizontal	-49.24	-13.00	36.24	135
10	8365.00	-56.29	4.30	12.50	Horizontal	-50.24	-13.00	37.24	135

Note: 1.The other Spurious RF Radiated emissions level is no more than noise floor.  
 2.The worst emission was found in the antenna is Horizontal position.

**LTE Band 26 5MHz CH-Middle**

Harmonic	Frequency (MHz)	SG (dBm)	Cable Loss (dB)	Gain (dBi)	Antenna Polarization	ERP Level (dBm)	Limit (dBm)	Margin (dB)	Azimuth (deg)
2	1668.75	-55.83	1.70	8.70	Horizontal	-50.98	-13.00	37.98	270
3	2502.94	-58.27	2.30	12.00	Horizontal	-50.72	-13.00	37.72	135
4	3346.00	-66.48	2.70	12.70	Horizontal	-58.63	-13.00	45.63	45
5	4182.50	-63.04	3.00	12.50	Horizontal	-55.69	-13.00	42.69	315
6	5019.00	-59.42	3.40	12.50	Horizontal	-52.47	-13.00	39.47	315
7	5855.50	-59.36	3.40	12.80	Horizontal	-52.11	-13.00	39.11	270
8	6692.00	-59.25	4.10	11.50	Horizontal	-54.00	-13.00	41.00	90
9	7528.50	-55.08	4.20	12.20	Horizontal	-49.23	-13.00	36.23	90
10	8365.00	-55.61	4.30	12.50	Horizontal	-49.56	-13.00	36.56	315

Note: 1.The other Spurious RF Radiated emissions level is no more than noise floor.  
 2.The worst emission was found in the antenna is Horizontal position.

**LTE Band 26 10MHz CH-Middle**

Harmonic	Frequency (MHz)	SG (dBm)	Cable Loss (dB)	Gain (dBi)	Antenna Polarization	ERP Level (dBm)	Limit (dBm)	Margin (dB)	Azimuth (deg)
2	1659.38	-65.07	1.70	8.70	Horizontal	-60.22	-13.00	47.22	135
3	2489.44	-66.70	2.30	12.00	Horizontal	-59.15	-13.00	46.15	45
4	3346.00	-66.12	2.70	12.70	Horizontal	-58.27	-13.00	45.27	225
5	4182.50	-63.44	3.00	12.50	Horizontal	-56.09	-13.00	43.09	45
6	5019.00	-58.98	3.40	12.50	Horizontal	-52.03	-13.00	39.03	0
7	5855.50	-59.06	3.40	12.80	Horizontal	-51.81	-13.00	38.81	0
8	6692.00	-58.37	4.10	11.50	Horizontal	-53.12	-13.00	40.12	0
9	7528.50	-55.30	4.20	12.20	Horizontal	-49.45	-13.00	36.45	90
10	8365.00	-55.41	4.30	12.50	Horizontal	-49.36	-13.00	36.36	315

Note: 1.The other Spurious RF Radiated emissions level is no more than noise floor.  
 2.The worst emission was found in the antenna is Horizontal position.

## 6. Main Test Instruments

Name	Manufacturer	Type	Serial Number	Calibration Date	Expiration Date
Base Station Simulator	R&S	CMW500	113645	2021-05-15	2022-05-14
Climate Chamber	Weiss	VT4002	58226119450 010	2021-05-15	2022-05-14
Spectrum Analyzer	Keysight	N9020A	MY52330084	2021-05-15	2022-05-14
Universal Radio Communication Tester	Key sight	E5515C	GB44400275	2021-05-15	2022-05-14
Signal Analyzer	R&S	FSV3030	101411	2021-12-12	2022-12-12
Signal Analyzer	R&S	FSV30	100815	2021-12-12	2022-12-11
TRILOG Broadband Antenna	Schwarzbeck	VULB 9163	01439	2021-06-30	2024-06-29
Horn Antenna	Schwarzbeck	BBHA 9120D	01799	2019-09-21	2022-09-20
Software	R&S	EMC32	9.26.0	/	/

\*\*\*\*\*END OF REPORT \*\*\*\*\*

## ANNEX A: The EUT Appearance

The EUT Appearance are submitted separately.

## ANNEX B: Test Setup Photos

The Test Setup Photos are submitted separately.