



# EMC TEST REPORT

**Applicant** Honor Device Co., Ltd.  
**FCC ID** 2AYGCTFY-LX3  
**Product** Smart Phone  
**Model** TFY-LX3  
**Report No.** R2201A0036-E1V2  
**Issue Date** February 16, 2022

TA Technology (Shanghai) Co., Ltd. tested the above equipment in accordance with the requirements in **FCC Code CFR47 Part15B (2020)/ ANSI C63.4 (2014)**. The test results show that the equipment tested is capable of demonstrating compliance with the requirements as documented in this report.

*Wei Liu*

Prepared by: Wei Liu

*Guangchang Fan*

Approved by: Guangchang Fan

---

**TA Technology (Shanghai) Co., Ltd.**

No.145, Jintang Rd, Tangzhen Industry Park, Pudong Shanghai, China

TEL: +86-021-50791141/2/3

FAX: +86-021-50791141/2/3-8000



## Table of Contents

|     |  |    |
|-----|--|----|
| 1   | Test Laboratory.....                             | 5  |
| 1.1 | Notes of the Test Report.....                    | 5  |
| 1.2 | Test facility.....                               | 5  |
| 1.3 | Testing Location.....                            | 5  |
| 2   | General Description of Equipment under Test..... | 6  |
| 2.1 | Applicant and Manufacturer Information.....      | 6  |
| 2.2 | General information.....                         | 6  |
| 2.3 | Applied Standards.....                           | 8  |
| 2.4 | Test Mode.....                                   | 9  |
| 3   | Test Case Results.....                           | 10 |
| 3.1 | Radiated Emission.....                           | 10 |
| 3.2 | Conducted Emission.....                          | 17 |
| 4   | Main Test Instruments.....                       | 22 |
|     | ANNEX A: The EUT Appearance.....                 | 23 |
|     | ANNEX B: Test Setup Photos.....                  | 24 |



| Version | Revision description                     | Issue Date        |
|---------|--|-------------------|
| Rev.0   | Initial issue of report.                 | January 28, 2022  |
| Rev.1   | Update information in Page 6 and Page 7. | February 9, 2022  |
| Rev.2   | Add FM data.                             | February 16, 2022 |

Note: This revised report (Report No. R2201A0036-E1V2) supersedes and replaces the previously issued report (Report No. R2201A0036-E1V1). Please discard or destroy the previously issued report and dispose of it accordingly.



### Summary of measurement results

| Number  | Test Case          | Clause in FCC Rules             | Conclusion |
|---|--------------------|---------------------------------|------------|
| 1   | Radiated Emission  | FCC Part15.109, ANSI C63.4-2014 | PASS       |
| 2   | Conducted Emission | FCC Part15.107, ANSI C63.4-2014 | PASS       |
| Date of Testing: January 13, 2022 ~ January 14, 2022 and February 15, 2022(for FM)<br>Date of Sample Received: January 10, 2022   |                    |                                 |            |
| Note: All indications of Pass/Fail in this report are opinions expressed by TA Technology (Shanghai) Co., Ltd. based on interpretations and/or observations of test results. Measurement Uncertainties were not taken into account and are published for informational purposes only. |                    |                                 |            |

## 1 Test Laboratory

### 1.1 Notes of the Test Report

This report shall not be reproduced in full or partial, without the written approval of **TA technology (shanghai) co., Ltd.** The results documented in this report apply only to the tested sample, under the conditions and modes of operation as described herein. Measurement Uncertainties were not taken into account and are published for informational purposes only. This report is written to support regulatory compliance of the applicable standards stated above.

### 1.2 Test facility

#### **FCC (Designation number: CN1179, Test Firm Registration Number: 446626)**

TA Technology (Shanghai) Co., Ltd. has been listed on the US Federal Communications Commission list of test facilities recognized to perform measurements.

#### **A2LA (Certificate Number: 3857.01)**

TA Technology (Shanghai) Co., Ltd. has been listed by American Association for Laboratory Accreditation to perform measurement.

### 1.3 Testing Location

Company: TA Technology (Shanghai) Co., Ltd.  
Address: No.145, Jintang Rd, Tangzhen Industry Park, Pudong Shanghai, China  
City: Shanghai  
Post code: 201201  
Country: P. R. China  
Contact: Fan Guangchang  
Telephone: +86-021-50791141/2/3  
Fax: +86-021-50791141/2/3-8000  
Website: <http://www.ta-shanghai.com>  
E-mail: [fanguangchang@ta-shanghai.com](mailto:fanguangchang@ta-shanghai.com)

## 2 General Description of Equipment under Test

### 2.1 Applicant and Manufacturer Information

|                             |  |
|-----------------------------|--|
| <b>Applicant</b>            | Honor Device Co., Ltd.   |
| <b>Applicant address</b>    | Shum Yip Sky Park, No. 8089, Hongli West Road, Shenzhen, China |
| <b>Manufacturer</b>         | Honor Device Co., Ltd.   |
| <b>Manufacturer address</b> | Shum Yip Sky Park, No. 8089, Hongli West Road, Shenzhen, China |

### 2.2 General information

| EUT Description        |  |               |               |
|------------------------|--|---------------|---------------|
| Device Type            | Portable Device                              |               |               |
| Model                  | TFY-LX3                                      |               |               |
| SN                     | A7NX011C30000083                             |               |               |
| HW Version             | HL6TFYM                                      |               |               |
| SW Version             | 4.2.0.35(C900E14R1P1)                        |               |               |
| Power Rating           | DC 3.87V from battery or DC 5V from Adapter. |               |               |
| Connecting I/O Port(s) | Please refer to the User's Manual.           |               |               |
| Antenna Type           | Internal Antenna                             |               |               |
| Frequency              | Band   | Tx (MHz)      | Rx (MHz)      |
|                        | GSM 850                                      | 824 ~ 849     | 869 ~ 894     |
|                        | GSM 1900                                     | 1850 ~ 1910   | 1930 ~ 1990   |
|                        | WCDMA Band II                                | 1850 ~ 1910   | 1930 ~ 1990   |
|                        | WCDMA Band IV                                | 1710 ~ 1755   | 2110 ~ 2155   |
|                        | WCDMA Band V                                 | 824 ~ 849     | 869 ~ 894     |
|                        | LTE Band 2                                   | 1850 ~ 1910   | 1930 ~ 1990   |
|                        | LTE Band 4                                   | 1710 ~ 1755   | 2110 ~ 2155   |
|                        | LTE Band 5                                   | 824 ~ 849     | 869 ~ 894     |
|                        | LTE Band 7                                   | 2500 ~ 2570   | 2620 ~ 2690   |
|                        | LTE Band 13                                  | 777 ~ 787     | 746 ~ 756     |
|                        | LTE Band 26                                  | 824 ~ 849     | 869 ~ 894     |
|                        | LTE Band 38                                  | 2570 ~ 2620   | 2570 ~ 2620   |
|                        | LTE Band 66                                  | 1710 ~ 1780   | 2110 ~ 2180   |
|                        | Bluetooth                                    | 2400 ~ 2483.5 | 2400 ~ 2483.5 |
|                        | Wi-Fi 2.4G                                   | 2400 ~ 2483.5 | 2400 ~ 2483.5 |
| Wi-Fi 5G(U-NII-1)      | 5150 ~ 5250                                  | 5150 ~ 5250   |               |



|  | Wi-Fi 5G(U-NII-2A)   | 5250 ~ 5350  | 5250 ~ 5350 |
|--|--|--|-------------|
|  | Wi-Fi 5G(U-NII-2C)   | 5470 ~ 5725  | 5470 ~ 5725 |
|  | Wi-Fi 5G(U-NII-3)  | 5725 ~ 5850  | 5725 ~ 5850 |
|  | FM   | /  | 87.5 ~ 108  |
| EUT Accessory  |  |  |             |
| Accessory  | Model  | Manufacture  | No.         |
| Adapter  | HW-100225E00   | Honor Device Co., Ltd.<br>(Manufacturer:Huntkey)                     | 1           |
|  | HW-100225U00   | Honor Device Co., Ltd.<br>(Manufacturer:Huntkey)                     | 2           |
|  | HW-100225B00   | Honor Device Co., Ltd.<br>(Manufacturer:Huntkey)                     | 3           |
|  | HN-100225E00   | Honor Device Co., Ltd.<br>(Manufacturer: Salcomp)                    | 4           |
|  | HN-100225U00   | Honor Device Co., Ltd.<br>(Manufacturer: Salcomp)                    | 5           |
| Battery  | HB416492EFW  | Honor Device Co., Ltd.<br>(Manufacturer: Sunwoda Electronic Co.,LTD) | 1           |
|  | HB416492EFW  | Honor Device Co., Ltd.<br>(Manufacturer:NVT)                         | 2           |
| Earphone   | MEND1532B528A11  | Jiangxi Lianchuang Hongsheng Electronic Co., LTD.                    | 1           |
|  | 1293-3283-3.5mm-339  | BOLUO COUNTY QUANCHENG ELECTRONIC<br>CO.,LTD.                        | 2           |
|  | EPAB542-2WH05-DH   | FOXCONN INTERCONNECT TECHNOLOGY LIMITED                              | 3           |
| USB Cable  | RY0002   | NingBo Broad Telecommunication Co., Ltd.                             | 1           |
|  | AU2-CRO013HF   | Freeport Resources Enterprises Corp.                                 | 2           |
|  | 2120-00001-0   | MING JI ELECTRONICS CO., LTD.  | 3           |
|  | L125UC007-CS-H   | LUXSHARE PRECISION INDUSTRY CO., LTD.                                | 4           |
|  | CUDU01B-HC451-EH   | FOXCONN INTERCONNECT TECHNOLOGY LIMITED                              | 5           |
| Auxiliary test equipment   |  |  |             |
| PC   | PC Manufacturer: Microsoft Corporation<br>Model: L20170076 |  |             |
| <p>Note: 1. The EUT is sent from the applicant to TA and the information of the EUT is declared by the applicant.</p> <p>2. There are more than one Adapter, Battery, Earphone and USB Cable, each one should be applied throughout the compliance test respectively, however, only the worst case (Adapter 1, Battery 2, Earphone 1 and USB Cable 3) will be recorded in this report.</p> |  |  |             |



## 2.3 Applied Standards

According to the specifications of the manufacturer, it must comply with the requirements of the following standards:

### Test standards

**FCC Code CFR47 Part15B (2020)**

**ANSI C63.4 (2014)**



## 2.4 Test Mode

| Test Mode |   |
|-----------|---|
| Mode 1:   | Adapter +USB cable+ earphone + Front camera On +GNSS Rx + GSM/WCDMA/LTE/ Bluetooth/ WLAN receiver |
| Mode 2:   | Adapter +USB cable+ earphone + Front camera On +GNSS Rx + GSM/WCDMA/LTE/ Bluetooth/ WLAN Traffic  |
| Mode 3:   | Adapter +USB cable+ earphone + Rear camera On +GNSS Rx + GSM/WCDMA/LTE/ Bluetooth/ WLAN receiver  |
| Mode4:    | Adapter +USB cable+ earphone + Rear camera On +GNSS Rx + GSM/WCDMA/LTE/ Bluetooth/ WLAN Traffic   |
| Mode 5:   | Adapter + USB cable + earphone + Mp4  |
| Mode 6:   | Adapter + USB cable + earphone + GSM/WCDMA/LTE/GNSS/ Bluetooth/ WLAN receiver                     |
| Mode 7:   | Adapter + USB cable + earphone + GSM/WCDMA/LTE/GNSS/ Bluetooth/ WLAN Traffic                      |
| Mode 8:   | USB Copy(EUT with PC) + USB cable + earphone  |
| Mode 9:   | Front Camera On +earphone + GNSS Rx + GSM/WCDMA/LTE/GPS/ Bluetooth/ WLAN receiver                 |
| Mode 10:  | Front Camera On +earphone + GNSS Rx + GSM/WCDMA/LTE/GPS/ Bluetooth/ WLAN Traffic                  |
| Mode 11:  | Rear camera On +earphone + GNSS Rx + GSM/WCDMA/LTE/GPS/ Bluetooth/ WLAN receiver                  |
| Mode 12:  | Rear camera On +earphone + GNSS Rx + GSM/WCDMA/LTE/GPS/ Bluetooth/ WLAN Traffic                   |
| Mode 13:  | Earphone + MP4  |
| Mode 14:  | Earphone + GNSS Rx + GSM/WCDMA/LTE/ Bluetooth/ WLAN receiver                                      |
| Mode 15:  | Earphone + GNSS Rx + GSM/WCDMA/LTE/ Bluetooth/ WLAN Traffic                                       |
| Mode 16:  | FM  |

During the test, the preliminary test was performed in all modes with all adapters, USB and batteries, mode 8 and mode16 is selected as the worst condition. The test data of the worst-case condition was recorded in this report.

### 3 Test Case Results

#### 3.1 Radiated Emission

##### Ambient condition

| Temperature | Relative humidity | Pressure |
|-------------|-------------------|----------|
| 15°C~35°C   | 30%~60%           | 101.5kPa |

##### Methods of Measurement

The EUT is placed on a non-metallic table 0.8m above the horizontal metal reference ground plane. The distance between EUT and receive antenna should be 3 meters. During the test, the EUT was operating in its typical mode. The test method is according to ANSI C63.4-2014. Sweep the whole frequency band through the range from 30MHz to the 5th harmonic of the carrier. During the test, the height of receive antenna shall be moved from 1 to 4 meters, and the antenna shall be performed under horizontal and vertical polarization. The turn table shall be rotated from 0 to 360 degrees for detecting the maximum of radiated signal level.

The data of cable loss and antenna factor has been calibrated in full testing frequency range before the testing. During the test, the EUT is worked at maximum output power.

Set the spectrum analyzer in the following:

Below 1GHz:

RBW=100 kHz / VBW=300 kHz / Sweep=AUTO

Above 1GHz:

(a) PEAK Detector: RBW=1MHz / VBW=3MHz / Sweep=AUTO

(b) AVERAGE Detector: RBW=1MHz / VBW=3MHz / Sweep=AUTO

The radiated emission was measured in the following position: EUT stand-up position (Z axis), lie-down position (X, Y axis). The worst emission was found in lie-down position (X axis) and the worst case was recorded.

During the test, EUT is connected to a laptop via a USB cable in the case of Transfer Data mode. The EUT is used as the peripheral equipment of the PC. The data is transferred from EUT to PC; PC is connected to server via a long LAN cable.

**Test Setup**

**Below 1GHz**

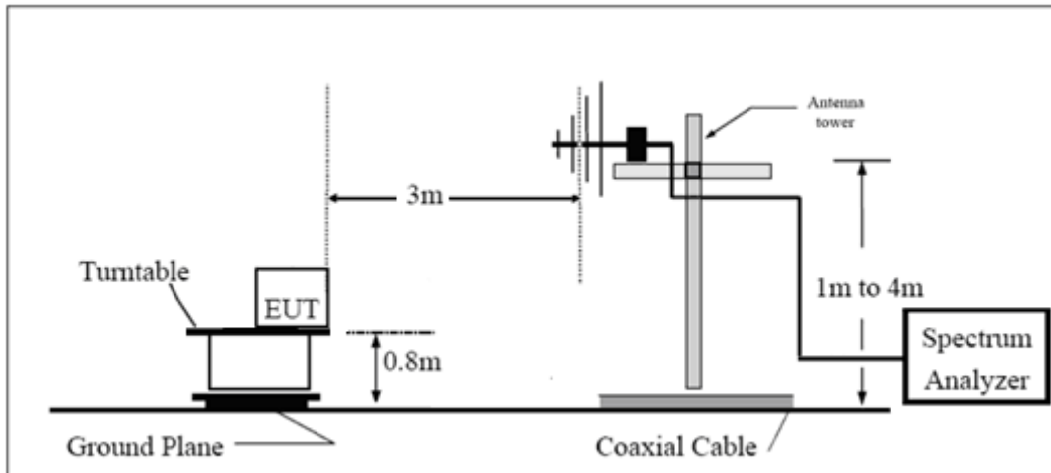

**Above 1GHz**

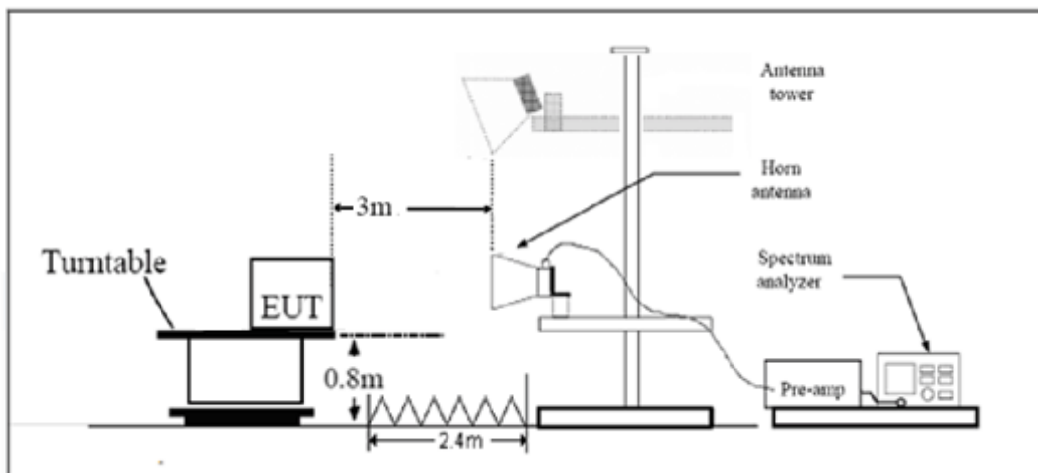

Note: Area side: 2.4mX3.6m

Antenna Tower meets ANSI C63.4 requirements for measurements above 1 GHz by keeping the antenna aimed at the EUT during the antenna's ascent/ descent along the antenna mast.

**Limits****Class B**

| Frequency (MHz)   | Field Strength (dB $\mu$ V/m) | Detector        |
|---|-------------------------------|-----------------|
| 30 -88  | 40.0                          | Quasi-peak      |
| 88-216  | 43.5                          | Quasi-peak      |
| 216 – 960   | 46.0                          | Quasi-peak      |
| 960-1000  | 54.0                          | Quasi-peak      |
| 1000-5 <sup>th</sup> harmonic of the highest frequency or 40GHz, which is lower | 54<br>74                      | Average<br>Peak |

**Measurement Uncertainty**

The assessed measurement uncertainty to ensure 95% confidence level for the normal distribution is with the coverage factor  $k = 1.96$ .

| Frequency      | Uncertainty |
|----------------|-------------|
| 30MHz~200MHz   | 4.17 dB     |
| 200MHz~1000MHz | 4.84 dB     |
| 1GHz~18GHz     | 4.35 dB     |

**Test Results**

Sweep the whole frequency band through the range from 30MHz to the 5th harmonic of the carrier.

The following graphs display the maximum values of horizontal and vertical by software.  
 For above 1GHz, Blue trace uses the peak detection, Green trace uses the average detection.  
 A font ( Level in dB  $\mu$  V/m )in the test plot =(level in dB  $\mu$  V/m)

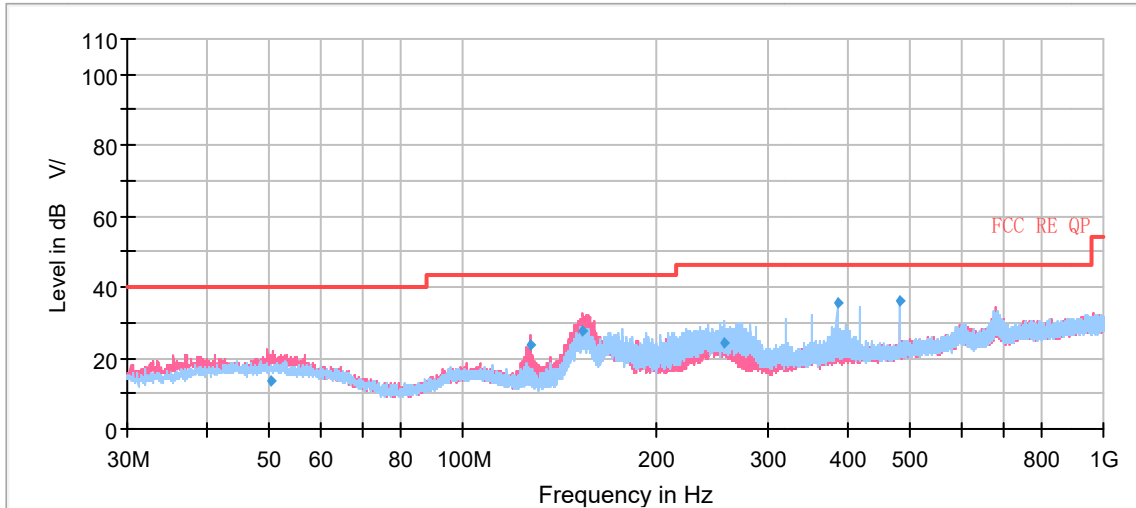

Radiated Emission from 30MHz to 1GHz

| Frequency (MHz) | Quasi-Peak (dBuV/m) | Limit (dBuV/m) | Margin (dB) | Height (cm) | Polarization | Azimuth (deg) | Correct Factor (dB) |
|-----------------|---------------------|----------------|-------------|-------------|--------------|---------------|---------------------|
| 50.163333       | 13.79               | 40.00          | 26.21       | 100.0       | V            | 52.0          | 21                  |
| 128.010000      | 23.88               | 43.50          | 19.62       | 100.0       | V            | 73.0          | 15                  |
| 154.218667      | 27.80               | 43.50          | 15.70       | 100.0       | V            | 83.0          | 15                  |
| 256.097667      | 24.47               | 46.00          | 21.53       | 125.0       | H            | 107.0         | 20                  |
| 383.985333      | 35.52               | 46.00          | 10.48       | 100.0       | H            | 342.0         | 23                  |
| 479.990667      | 35.95               | 46.00          | 10.05       | 100.0       | H            | 193.0         | 24                  |

- Remark: 1. Correction Factor = Antenna factor + Insertion loss(cable loss+amplifier gain)
- 2. Margin = Limit – Quasi-Peak

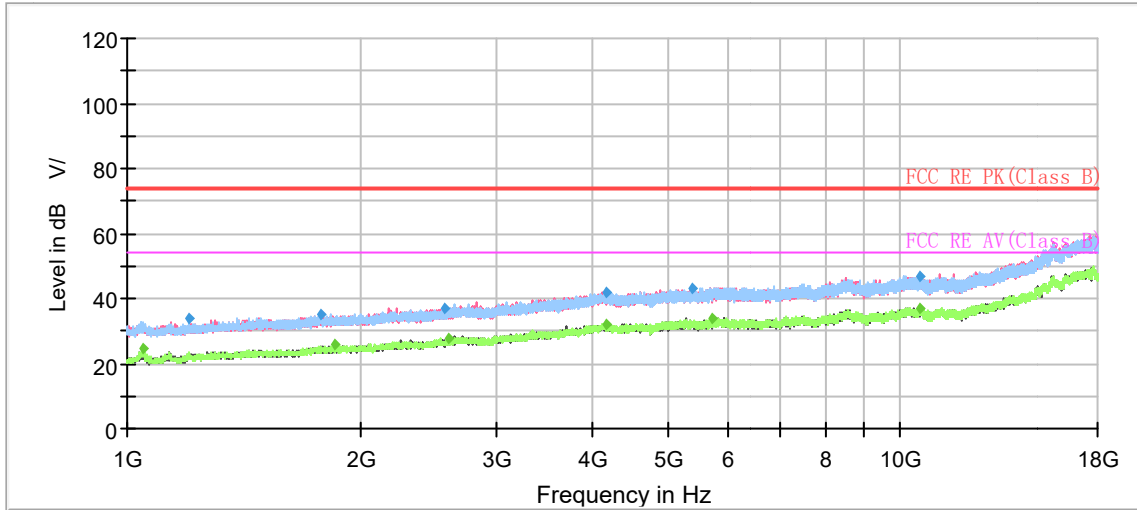

Radiated Emission from 1GHz to 18GHz

| Frequency (MHz) | Peak (dBuV/m) | Average (dBuV/m) | Limit (dBuV/m) | Margin (dB) | Height (cm) | Polarization | Azimuth (deg) | Correct Factor (dB) |
|-----------------|---------------|------------------|----------------|-------------|-------------|--------------|---------------|---------------------|
| 1048.166667     | ---           | 24.58            | 54.00          | 29.42       | 100.0       | H            | 220.0         | -19                 |
| 1199.466667     | 33.97         | ---              | 74.00          | 40.03       | 100.0       | H            | 236.0         | -18                 |
| 1784.833333     | 35.33         | ---              | 74.00          | 38.67       | 200.0       | V            | 212.0         | -14                 |
| 1854.533333     | ---           | 25.67            | 54.00          | 28.33       | 100.0       | V            | 163.0         | -14                 |
| 2573.066667     | 37.13         | ---              | 74.00          | 36.87       | 100.0       | V            | 84.0          | -10                 |
| 2611.600000     | ---           | 27.59            | 54.00          | 26.41       | 100.0       | H            | 322.0         | -10                 |
| 4159.166667     | ---           | 32.28            | 54.00          | 21.72       | 100.0       | V            | 227.0         | -3                  |
| 4178.433333     | 41.85         | ---              | 74.00          | 32.15       | 100.0       | H            | 354.0         | -3                  |
| 5366.166667     | 43.22         | ---              | 74.00          | 30.78       | 100.0       | V            | 0.0           | -1                  |
| 5720.900000     | ---           | 34.10            | 54.00          | 19.90       | 200.0       | H            | 12.0          | 0                   |
| 10625.966667    | ---           | 37.19            | 54.00          | 16.81       | 200.0       | H            | 169.0         | 5                   |
| 10628.233333    | 46.92         | ---              | 74.00          | 27.08       | 200.0       | H            | 58.0          | 5                   |

RE 18-26.5GHz PK+AV

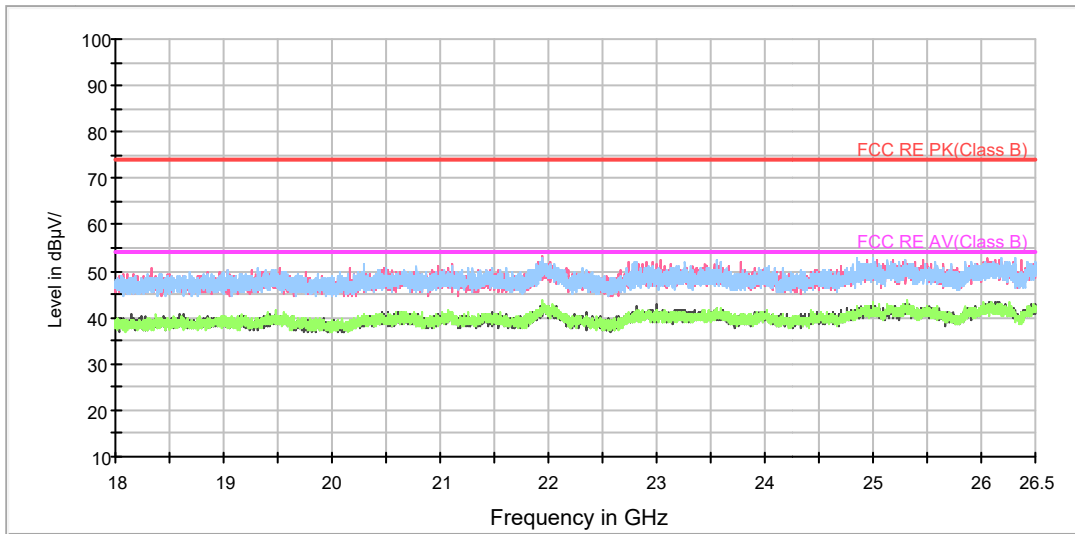

Radiated Emission from 18GHz to 26.5GHz

RE 26.5-40GHz PK+AV

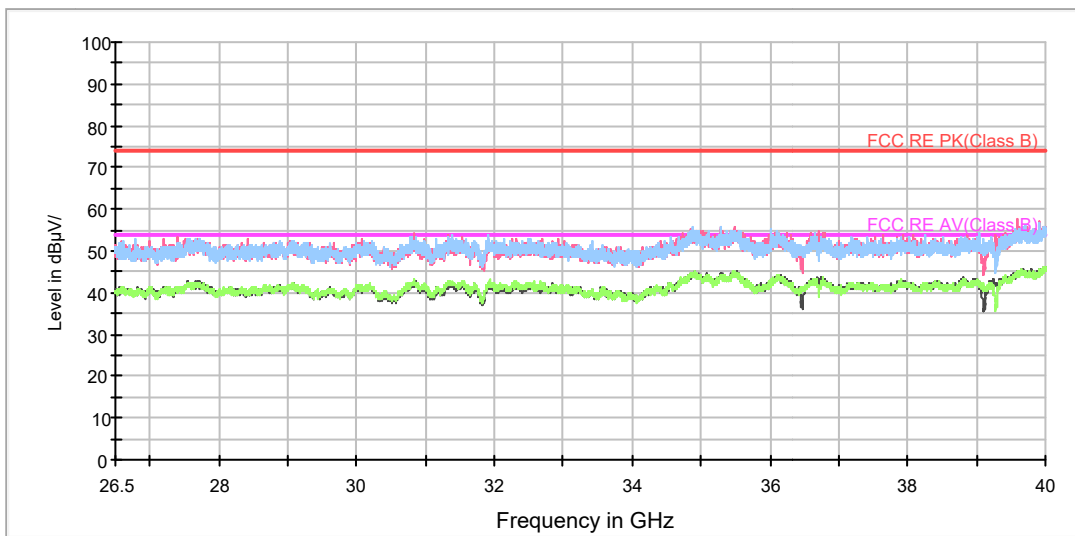

Radiated Emission from 26.5GHz to 40GHz

**FM**

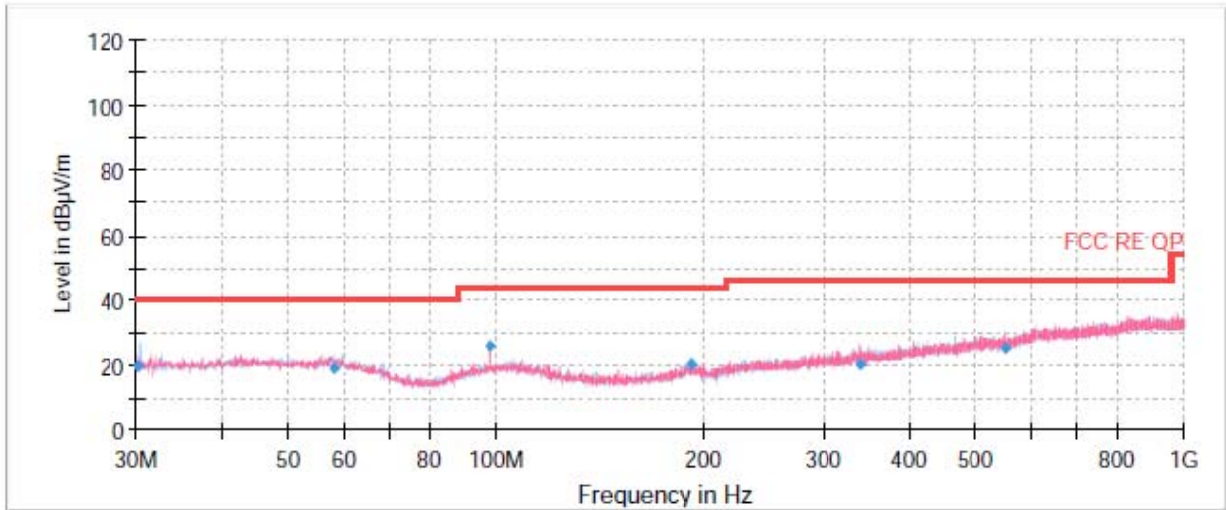

Radiated Emission from 30MHz to 1GHz

| Frequency (MHz) | Quasi-Peak (dBµV/m) | Limit (dBµV/m) | Margin (dB) | Meas. Time (ms) | Height (cm) | Polarization | Azimuth (deg) | Correct Factor (dB) |
|-----------------|---------------------|----------------|-------------|-----------------|-------------|--------------|---------------|---------------------|
| 30.16           | 19.63               | 40.00          | 20.37       | 1000.00         | 190.0       | H            | 235.00        | 12                  |
| 58.01           | 18.78               | 40.00          | 21.22       | 1000.00         | 100.0       | H            | 108.00        | 14                  |
| 97.98           | 25.89               | 43.50          | 14.61       | 1000.00         | 100.0       | V            | 102.00        | 13                  |
| 191.99          | 20.39               | 43.50          | 23.11       | 1000.00         | 125.0       | H            | 92.00         | 12                  |
| 338.50          | 20.48               | 46.00          | 25.52       | 1000.00         | 100.0       | H            | 276.00        | 16                  |
| 552.59          | 24.99               | 46.00          | 21.01       | 1000.00         | 213.0       | V            | 50.00         | 20                  |

- Remark: 1. Correction Factor = Antenna factor + Insertion loss(cable loss+amplifier gain)**  
**2. Margin = Limit – Quasi-Peak**



### 3.2 Conducted Emission

#### Ambient condition

| Temperature | Relative humidity | Pressure |
|-------------|-------------------|----------|
| 15°C~35°C   | 30%~60%           | 101.5kPa |

#### Methods of Measurement

The EUT is placed on a non-metallic table of 80cm height above the horizontal metal reference ground plane. During the test, the EUT was operating in its typical mode. The test method is according to ANSI C63.4-2014. Connect the AC power line of the EUT to the L.I.S.N. Use EMI receiver to detect the average and Quasi-peak value. RBW is set to 9 kHz, VBW is set to 30kHz. The measurement result should include both L line and N line.

During the test, EUT is connected to a laptop via a USB cable in the case of Transfer Data mode. The EUT is used as the peripheral equipment of the PC. The data is transferred from EUT to PC; PC is connected to server via a long LAN cable.

#### Test Setup

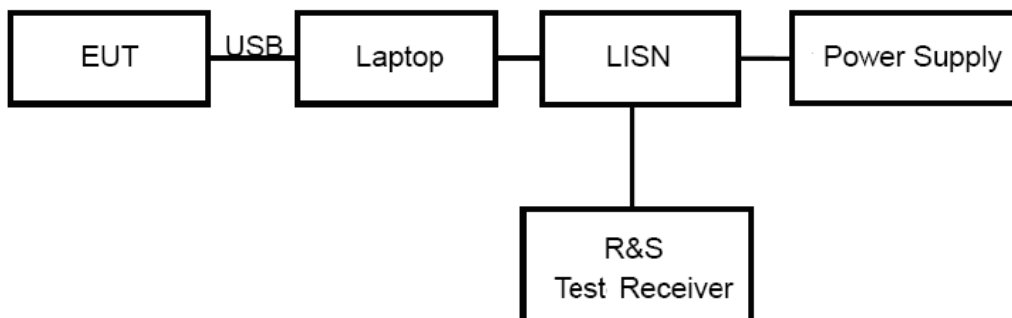

Note: Power Supply is AC Power source and it is used to change the voltage 120V/60Hz.

#### Limits

| Frequency (MHz) | Conducted Limits(dBμV) |            |
|-----------------|------------------------|------------|
|                 | Quasi-peak             | Average    |
| 0.15 - 0.5      | 66 to 56 *             | 56 to 46 * |
| 0.5 - 5         | 56                     | 46         |
| 5 - 30          | 60                     | 50         |

\*: Decreases with the logarithm of the frequency.

#### Measurement Uncertainty

The assessed measurement uncertainty to ensure 95% confidence level for the normal distribution is with the coverage factor  $k = 1.96$ .  $U = 2.57$  dB.

**Test Results**

Following plots, Blue trace uses the peak detection; Green trace uses the average detection.

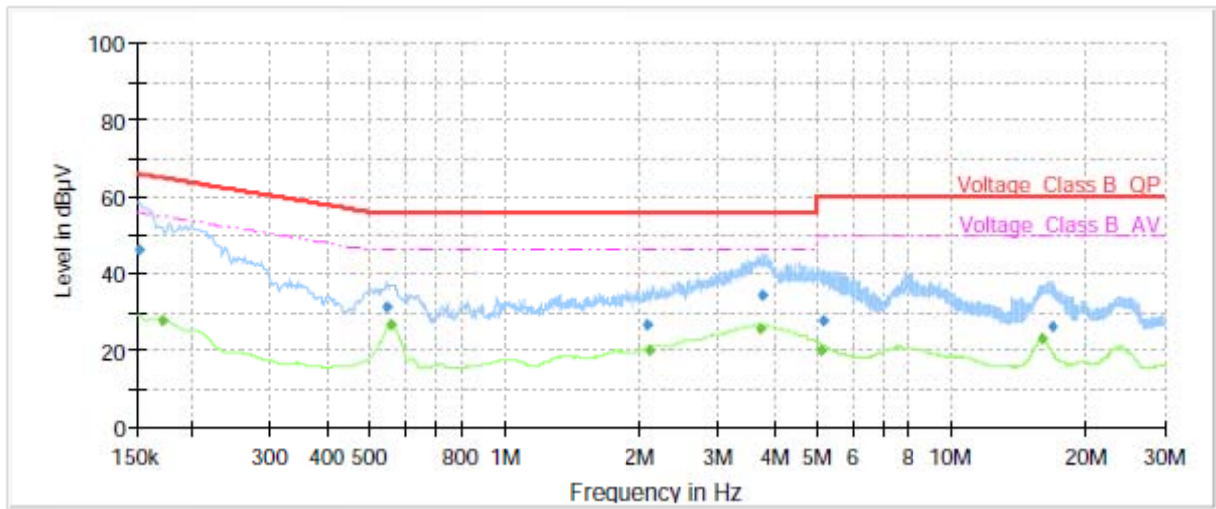

| Frequency (MHz) | QuasiPeak (dBµV) | Average (dBµV) | Limit (dBµV) | Margin (dB) | Meas. Time (ms) | Bandwidth (kHz) | Line | Filter | Corr. (dB) |
|-----------------|------------------|----------------|--------------|-------------|-----------------|-----------------|------|--------|------------|
| 0.15            | 46.15            | ---            | 65.88        | 19.73       | 70.0            | 9.000           | L1   | ON     | 21         |
| 0.17            | ---              | 27.62          | 54.95        | 27.33       | 70.0            | 9.000           | L1   | ON     | 21         |
| 0.55            | 31.22            | ---            | 56.00        | 24.78       | 70.0            | 9.000           | L1   | ON     | 20         |
| 0.56            | ---              | 26.88          | 46.00        | 19.12       | 70.0            | 9.000           | L1   | ON     | 20         |
| 2.09            | 26.61            | ---            | 56.00        | 29.39       | 70.0            | 9.000           | L1   | ON     | 20         |
| 2.12            | ---              | 19.93          | 46.00        | 26.07       | 70.0            | 9.000           | L1   | ON     | 20         |
| 3.74            | ---              | 25.79          | 46.00        | 20.21       | 70.0            | 9.000           | L1   | ON     | 19         |
| 3.76            | 34.13            | ---            | 56.00        | 21.87       | 70.0            | 9.000           | L1   | ON     | 19         |
| 5.13            | ---              | 19.80          | 50.00        | 30.20       | 70.0            | 9.000           | L1   | ON     | 19         |
| 5.15            | 27.69            | ---            | 60.00        | 32.31       | 70.0            | 9.000           | L1   | ON     | 19         |
| 16.01           | ---              | 23.14          | 50.00        | 26.86       | 70.0            | 9.000           | L1   | ON     | 20         |
| 16.79           | 26.17            | ---            | 60.00        | 33.83       | 70.0            | 9.000           | L1   | ON     | 20         |

**Remark: Correct factor=cable loss + LISN factor**

L line

Conducted Emission from 150 KHz to 30 MHz

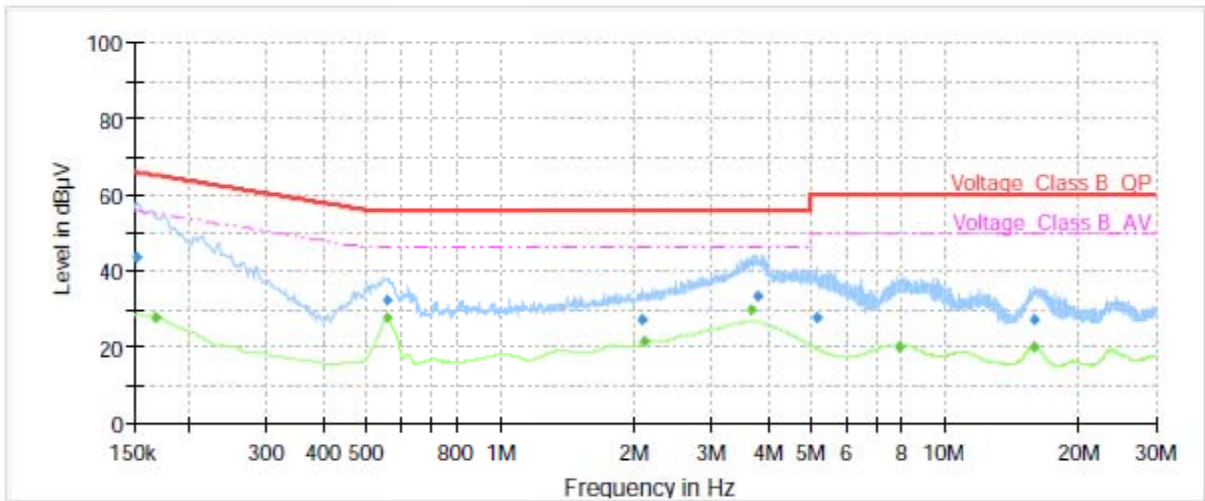

| Frequency (MHz) | QuasiPeak (dBµV) | Average (dBµV) | Limit (dBµV) | Margin (dB) | Meas. Time (ms) | Bandwidth (kHz) | Line | Filter | Corr. (dB) |
|-----------------|------------------|----------------|--------------|-------------|-----------------|-----------------|------|--------|------------|
| 0.15            | 43.51            | ---            | 65.88        | 22.37       | 70.0            | 9.000           | N    | ON     | 21         |
| 0.17            | ---              | 27.46          | 55.06        | 27.61       | 70.0            | 9.000           | N    | ON     | 21         |
| 0.56            | ---              | 27.75          | 46.00        | 18.25       | 70.0            | 9.000           | N    | ON     | 20         |
| 0.56            | 32.24            | ---            | 56.00        | 23.76       | 70.0            | 9.000           | N    | ON     | 20         |
| 2.10            | 27.43            | ---            | 56.00        | 28.57       | 70.0            | 9.000           | N    | ON     | 20         |
| 2.12            | ---              | 21.65          | 46.00        | 24.35       | 70.0            | 9.000           | N    | ON     | 20         |
| 3.68            | ---              | 29.74          | 46.00        | 16.26       | 70.0            | 9.000           | N    | ON     | 19         |
| 3.80            | 33.49            | ---            | 56.00        | 22.51       | 70.0            | 9.000           | N    | ON     | 19         |
| 5.19            | 27.45            | ---            | 60.00        | 32.55       | 70.0            | 9.000           | N    | ON     | 19         |
| 7.95            | ---              | 20.05          | 50.00        | 29.95       | 70.0            | 9.000           | N    | ON     | 20         |
| 15.94           | 27.06            | ---            | 60.00        | 32.94       | 70.0            | 9.000           | N    | ON     | 20         |
| 15.96           | ---              | 20.20          | 50.00        | 29.80       | 70.0            | 9.000           | N    | ON     | 20         |

Remark: Correct factor=cable loss + LISN factor

N line

Conducted Emission from 150 KHz to 30 MHz

FM

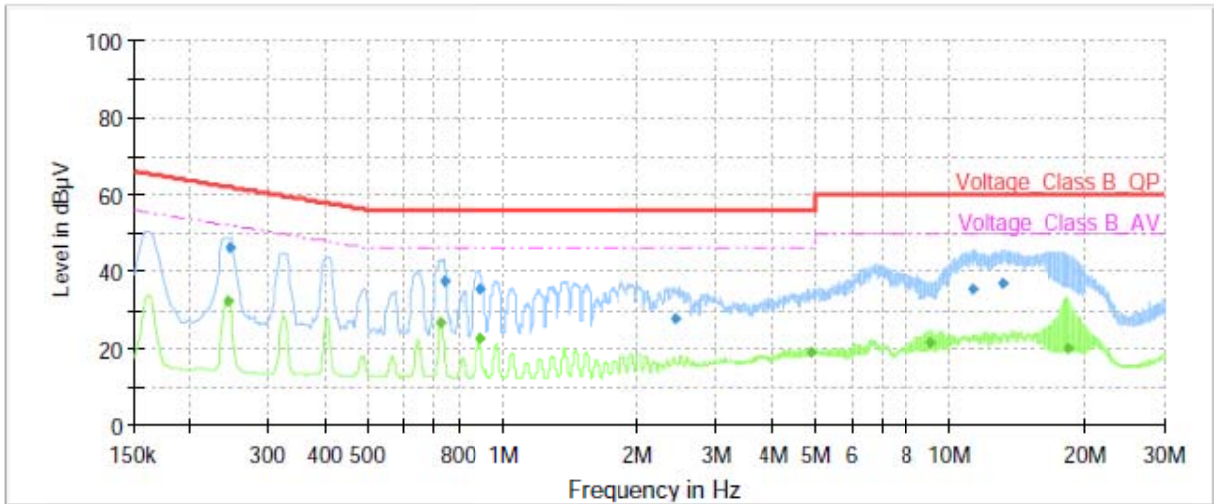

| Frequency (MHz) | QuasiPeak (dBµV) | Average (dBµV) | Limit (dBµV) | Margin (dB) | Meas. Time (ms) | Bandwidth (kHz) | Line | Filter | Corr. (dB) |
|-----------------|------------------|----------------|--------------|-------------|-----------------|-----------------|------|--------|------------|
| 0.24            | ---              | 32.50          | 52.02        | 19.52       | 70.00           | 9.000           | L1   | ON     | 21         |
| 0.24            | 46.07            | ---            | 61.94        | 15.87       | 70.00           | 9.000           | L1   | ON     | 21         |
| 0.73            | ---              | 26.49          | 46.00        | 19.51       | 70.00           | 9.000           | L1   | ON     | 20         |
| 0.74            | 37.50            | ---            | 56.00        | 18.50       | 70.00           | 9.000           | L1   | ON     | 20         |
| 0.89            | ---              | 22.55          | 46.00        | 23.45       | 70.00           | 9.000           | L1   | ON     | 20         |
| 0.89            | 35.22            | ---            | 56.00        | 20.78       | 70.00           | 9.000           | L1   | ON     | 20         |
| 2.42            | 27.93            | ---            | 56.00        | 28.07       | 70.00           | 9.000           | L1   | ON     | 19         |
| 4.91            | ---              | 18.85          | 46.00        | 27.15       | 70.00           | 9.000           | L1   | ON     | 19         |
| 9.02            | ---              | 21.74          | 50.00        | 28.26       | 70.00           | 9.000           | L1   | ON     | 20         |
| 11.24           | 35.51            | ---            | 60.00        | 24.49       | 70.00           | 9.000           | L1   | ON     | 20         |
| 13.02           | 36.69            | ---            | 60.00        | 23.31       | 70.00           | 9.000           | L1   | ON     | 20         |
| 18.28           | ---              | 19.85          | 50.00        | 30.15       | 70.00           | 9.000           | L1   | ON     | 20         |

Remark: Correct factor=cable loss + LISN factor

L line

Conducted Emission from 150 KHz to 30 MHz

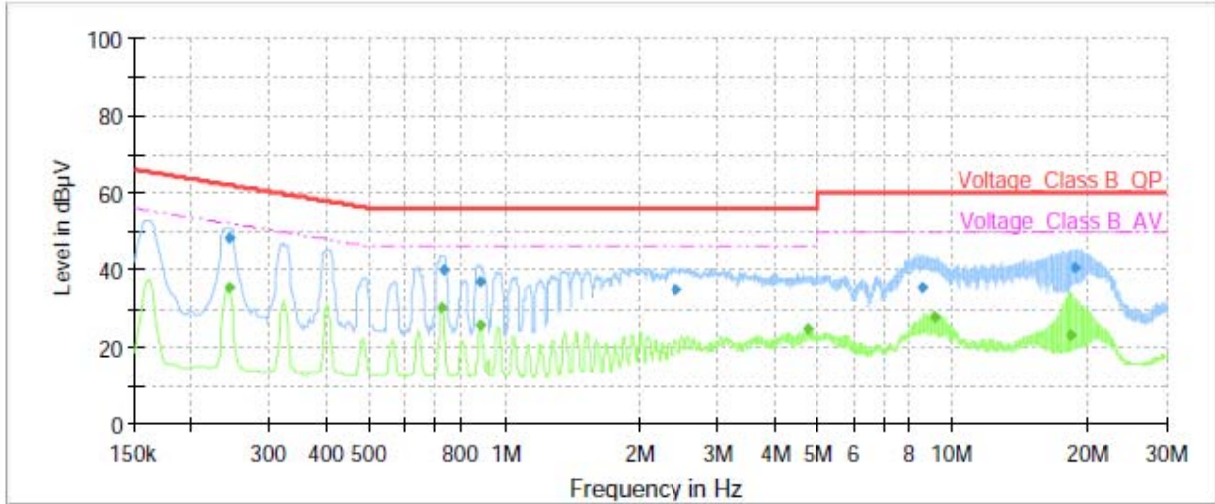

| Frequency (MHz) | QuasiPeak (dBµV) | Average (dBµV) | Limit (dBµV) | Margin (dB) | Meas. Time (ms) | Bandwidth (kHz) | Line | Filter | Corr. (dB) |
|-----------------|------------------|----------------|--------------|-------------|-----------------|-----------------|------|--------|------------|
| 0.24            | ---              | 35.63          | 52.02        | 16.39       | 70.00           | 9.000           | N    | ON     | 21         |
| 0.24            | 48.41            | ---            | 62.02        | 13.61       | 70.00           | 9.000           | N    | ON     | 21         |
| 0.72            | ---              | 30.36          | 46.00        | 15.64       | 70.00           | 9.000           | N    | ON     | 20         |
| 0.73            | 39.95            | ---            | 56.00        | 16.05       | 70.00           | 9.000           | N    | ON     | 20         |
| 0.88            | ---              | 25.87          | 46.00        | 20.13       | 70.00           | 9.000           | N    | ON     | 20         |
| 0.88            | 36.82            | ---            | 56.00        | 19.18       | 70.00           | 9.000           | N    | ON     | 20         |
| 2.40            | 34.74            | ---            | 56.00        | 21.26       | 70.00           | 9.000           | N    | ON     | 20         |
| 4.72            | ---              | 24.53          | 46.00        | 21.47       | 70.00           | 9.000           | N    | ON     | 19         |
| 8.51            | 35.52            | ---            | 60.00        | 24.48       | 70.00           | 9.000           | N    | ON     | 20         |
| 9.11            | ---              | 27.63          | 50.00        | 22.37       | 70.00           | 9.000           | N    | ON     | 20         |
| 18.30           | ---              | 22.85          | 50.00        | 27.15       | 70.00           | 9.000           | N    | ON     | 20         |
| 18.78           | 40.44            | ---            | 60.00        | 19.56       | 70.00           | 9.000           | N    | ON     | 20         |

Remark: Correct factor=cable loss + LISN factor

N line

Conducted Emission from 150 KHz to 30 MHz

## 4 Main Test Instruments

| Name                    | Manufacturer | Type              | Serial Number | Calibration Date | Expiration Time |
|-------------------------|--------------|-------------------|---------------|------------------|-----------------|
| Spectrum Analyzer       | R&S          | FSV40             | 15195-01-00   | 2021-05-15       | 2022-05-14      |
| EMI Test Receiver       | R&S          | ESCI              | 100948        | 2021-05-15       | 2022-05-14      |
| Trilog Antenna          | SCHWARZBECK  | VULB 9163         | 391           | 2019-12-16       | 2022-12-15      |
| Horn Antenna            | R&S          | HF907             | 102723        | 2020-08-11       | 2023-08-10      |
| Horn Antenna            | ETS-Lindgren | 3160-09           | 00102643      | 2021-10-10       | 2024-10-09      |
| Horn Antenna            | STEATITE     | QSH-SL-26-40-K-15 | 16779         | 2019-12-24       | 2022-12-23      |
| EMI Test Receiver       | R&S          | ESR               | 101667        | 2021-05-16       | 2022-05-15      |
| LISN                    | R&S          | ENV216            | 101171        | 2020-12-13       | 2022-12-12      |
| Bore Sight Antenna mast | ETS          | 2171B             | 00058752      | /                | /               |
| Test software           | EMC32        | R&S               | 9.26.0        | /                | /               |

\*\*\*\*\*END OF REPORT \*\*\*\*\*



## **ANNEX A: The EUT Appearance**

The EUT Appearance are submitted separately.



## **ANNEX B: Test Setup Photos**

The Test Setup Photos are submitted separately.