



SAR TEST REPORT

Report No.: 20230517G05491X-W9

Product Name: Smart LTE Terminal

Model Name: TE620,TELOX-TE620,Telo-TE620,TE620A,TE620B,TE620C,TE620D,TE620E,TE620F,TELOX_TE620G,TE620H,TE620J,TE620K,TE620L,TE620M,TE620Q,TE620R,TE620S,TE620T,TE620U,TE620V,TE620X,TE620Y

Trade Name: TELOX

Brand Name: TELOX

FCC ID: 2AYEZ-TE620G

Applicant: Telo Communication (Shenzhen) Co., Ltd

Address: 6/F, No.42 Liuxian 1st Road, Bao'an District, Shenzhen, China

Test Date: 2023/08/03~2023/08/17

Issued by: CCIC Southern Testing Co., Ltd.

Lab Location: Electronic Testing Building, No. 43 Shahe Road Xili Street, Nanshan District, Shenzhen, Guangdong 518055, China

Tel: 86 755 26627338 **Fax:** 86 755 26627238

Mail: manager@ccic-set.com Website <http://www.ccic-set.com>

This test report consists of 84 pages in total. It may be duplicated completely for legal use with the approval of the applicant. It should not be reproduced except in full, without the written approval of our laboratory. The client should not use it to claim product endorsement by CCIC-SET. The test results in the report only apply to the tested sample. The test report shall be invalid without all the signatures of testing engineers, reviewer and approver. Any objections must be raised to CCIC-SET within 15 days since the date when the report is received. It will not be taken into consideration beyond this limit.



Test Report

Applicant: Telo Communication (Shenzhen) Co., Ltd

Applicant Address: 6/F, No.42 Liuxian 1st Road, Bao'an District, Shenzhen, China

Manufacturer: Telo Communication (Shenzhen) Co., Ltd

Manufacturer Address: 6/F, No.42 Liuxian 1st Road, Bao'an District, Shenzhen, China

47CFR §2.1093- Radiofrequency Radiation Exposure Evaluation:
Portable Devices;

ANSI C95.1-1992: Safety Levels with Respect to Human Exposure to
Radio Frequency Electromagnetic Fields, 3 kHz – 300 GHz.(IEEE Std
Test Standards: C95.1-1991)

IEEE 1528-2013: IEEE Recommended Practice for Determining the
Peak Spatial-Average Specific Absorption Rate (SAR) in the Human
Head from Wireless Communications Devices: Measurement
Techniques

Test Result: Pass

Tested by: Carl Wei 2023-08-18

Carl Wei, Test Engineer

Reviewed by: Chris You 2023-08-18

Chris You, Senior Engineer

Approved by: Yang Fan 2023-08-18

Yang Fan, Manager



Contents

Test Report	2
1. Administrative Data	4
2. Equipment Under Test (EUT)	5
3. SAR Summary	7
4. Specific Absorption Rate (SAR)	10
5. Tissue check and recommend Dielectric Parameters	14
6. SAR measurement procedure	19
7. Conducted RF Output Power	20
8. Antenna Location:	50
9. Scaling Factor calculation	52
10. Test Results	55
11. Simultaneous Transmissions Analysis	75
12. Measurement Uncertainty	79
13. Equipment List	83
ANNEX A: Appendix A: SAR System performance Check Plots	84
ANNEX B: Appendix B: SAR Measurement results Plots	84
ANNEX C: Appendix C: Calibration reports	84
ANNEX D: Appendix D: SAR Test Setup	84



1. Administrative Data

1.1 Testing Laboratory

Test Site:	CCIC Southern Testing Co., Ltd.
Address:	Electronic Testing Building, No. 43 Shahe Road Xili Street, Nanshan District, Shenzhen, Guangdong 518055, China
A2LA Lab Code:	CCIC-SET is a third party testing organization accredited by A2LA according to ISO/IEC 17025:2017. The accreditation certificate number is 5721.01
FCC Registration:	CCIC Southern Testing Co., Ltd. EMC Laboratory has been registered and fully described in a report filed with the FCC (Federal Communications Commission). The acceptance letter from the FCC is maintained in our files. Designation Number: CN1283, valid time is until Sep 30th, 2023.
ISED Registration:	CCIC Southern Testing Co., Ltd. EMC Laboratory has been registered by Certification and Engineering Bureau of Industry Canada for the performance of radiated measurements with Registration No. 11185A-1 on Aug. 04, 2016, valid time is until Sep 30th, 2023.
Test Environment Condition:	Temperature (°C): 18°C ~25°C Relative Humidity (%): 35%~75% RH Atmospheric Pressure (kPa): 86KPa-106KPa

2. Equipment Under Test (EUT)

Identification of the Equipment under Test

Device type :	portable device	
Exposure category:	uncontrolled environment / general population	
Product Name:	Smart LTE Terminal	
Brand Name:	TELOX	
Model Name:	TE620,TELOX-TE620,Telo-TE620,TE620A,TE620B,TE620C,TE620D,TE620E,TE620F,TELOX_TE620G,TE620H,TE620J,TE620K,TE620L,TE620M,TE620Q,TE620R,TE620S,TE620T,TE620U,TE620V,TE620X,TE620Y	
Operating Band(s):	GSM850/1900, UMTS Band II/IV/V, LTE Band 2,4,5,7,12,13,17,26,41,66 WIFI2.4G, WIFI5G (Band 1,4) ,BT	
Test Band(s):	GSM850/1900, UMTS Band II/IV/V, LTE Band 2,4,5,7,12,13,17,26,41,66 WIFI2.4G, WIFI5G (Band 1,4) ,BT	
Test modulation:	GSM(GMSK,8PSK),UMTS(QPSK),LTE(QPSK/16QAM/64QAM), WI-FI 2.4G(DSSS, OFDM), WI-FI 5G(OFDM), BT(GFSK/ π /4-DQPSK/8-DPSK)	
IMEI:	IMEI 1:350008470015123 IMEI 2:350008470025122	
Device Class:	B, GPRS:12, EDGE:12	
Tested frequency range(s)	transmitter frequency range	receiver frequency range
GSM 850:	824-849 MHz	869-894 MHz
GSM 1900:	1850-1910 MHz	1930-1990 MHz
UMTS Band V:	824-849 MHz	869-894 MHz
UMTS Band IV:	1710-1755 MHz	2110-2155 MHz
UMTS Band II:	1850-1910 MHz	1930-1990 MHz
LTE Band 2:	1850-1910 MHz	1930-1990 MHz
LTE Band 4:	1710-1755 MHz	2110-2155 MHz
LTE Band 5:	824-849 MHz	869-894 MHz
LTE Band 7:	2500-2570 MHz	2620-2690 MHz
LTE Band 12:	698-716 MHz	728-746 MHz
LTE Band 13:	777-787 MHz	746-756 MHz
LTE Band 17:	704-716 MHz	734-746 MHz
LTE Band 26:	814-849 MHz	859-894 MHz
LTE Band 41:	2535-2655 MHz	
LTE Band 66:	1710-1780 MHz	2110-2200 MHz
Wi-Fi:	2412-2462 MHz	
	5150-5250 MHz	
	5725-5850 MHz	
Bluetooth:	2402-2480 MHz	
Antenna type :	Internal antenna	



Hotspot :	2.4GHz WLAN support Hotspot mode
Battery options :	Model No.: TSRB-5000(M) Capacitance: 5000mAh Rated Voltage: 3.8V Charge Limit: 4.35V Manufacturer: ShenZhen Wintide Technology Co.,Ltd Dong Guan Branch
MAX. SAR Value:	Head: 0.595 W/Kg(Limit:1.6W/Kg, 0mm distance) Body-worn: 0.978 W/Kg(Limit:1.6W/Kg, 10mm distance) Hotspot: 1.175 W/Kg(Limit:1.6W/Kg, 10mm distance)

Note:

1. The above EUT's information was declared by manufacturer. Please refer to the specifications or user's manual for more detailed description.
2. EUT all models were identical inside, the electrical circuit design, layout, components used and internal wiring, with only difference being model name.



3. SAR Summary

Highest Standalone SAR Summary

Exposure Position	Frequency Band	Scaled 1g-SAR(W/kg)	Highest Scaled 1g-SAR(W/kg)
Head	GSM 850 ANT 3	0.302	0.595
	GSM 1900 ANT 3	0.385	
	WCDMA 850 ANT 3	0.433	
	WCDMA 1700 ANT 3	0.413	
	WCDMA 1900 ANT 3	0.334	
	LTE Band 2 ANT 3	0.452	
	LTE Band 4 ANT 3	0.445	
	LTE Band 5 ANT 3	0.524	
	LTE Band 7 ANT 3	0.281	
	LTE Band 12 ANT 3	0.221	
	LTE Band 13 ANT 3	0.595	
	LTE Band 17 ANT 3	0.260	
	LTE Band 26 (Part 22)ANT 3	0.523	
	LTE Band 26 (Part 90)ANT 3	0.544	
	LTE Band 41 ANT 3	0.167	
	LTE Band 66 ANT 3	0.570	
	WIFI 2.4G ANT 2	0.443	
	WIFI 5G U-NII 1 ANT 2	0.296	
	WIFI 5G U-NII 3 ANT 2	0.446	
	BT ANT 2	0.066	



Exposure Position	Frequency Band	Scaled 1g-SAR(W/kg)	Highest Scaled 1g-SAR(W/kg)
Body-worn (10mm Gap)	GSM 850 ANT 3	0.501	0.978
	GSM 1900 ANT 3	0.430	
	WCDMA 850 ANT 3	0.419	
	WCDMA 1700 ANT 3	0.450	
	WCDMA 1900 ANT 3	0.546	
	LTE Band 2 ANT 3	0.626	
	LTE Band 4 ANT 3	0.762	
	LTE Band 5 ANT 3	0.461	
	LTE Band 7 ANT 3	0.748	
	LTE Band 12 ANT 3	0.281	
	LTE Band 13 ANT 3	0.609	
	LTE Band 17 ANT 3	0.300	
	LTE Band 26 (Part 22)ANT 3	0.513	
	LTE Band 26 (Part 90)ANT 3	0.483	
	LTE Band 41 ANT 3	0.978	
	LTE Band 66 ANT 3	0.691	
	WIFI 2.4G ANT 2	0.164	
	WIFI 5G U-NII 1 ANT 2	0.521	
	WIFI 5G U-NII 3 ANT 2	0.360	
BT ANT 2	0.082		



Exposure Position	Frequency Band	Scaled 1g-SAR(W/kg)	Highest Scaled 1g-SAR(W/kg)
Hotspot (10mm Gap)	GSM 850 ANT 3	0.501	1.175
	GSM 1900 ANT 3	0.575	
	WCDMA 850 ANT 3	0.419	
	WCDMA 1700 ANT 3	0.512	
	WCDMA 1900 ANT 3	0.546	
	LTE Band 2 ANT 3	0.686	
	LTE Band 4 ANT 3	0.762	
	LTE Band 5 ANT 3	0.461	
	LTE Band 7 ANT 3	0.869	
	LTE Band 12 ANT 3	0.281	
	LTE Band 13 ANT 3	0.609	
	LTE Band 17 ANT 3	0.300	
	LTE Band 26 (Part 22)ANT 3	0.513	
	LTE Band 26 (Part 90)ANT 3	0.483	
	LTE Band 41 ANT 3	1.175	
	LTE Band 66 ANT 3	0.717	
	WIFI 2.4G ANT 2	0.164	

Highest Simultaneous SAR Summary

Exposure Position	Frequency Band	Highest Simultaneous 1g-SAR(W/kg)
Body-worn (10mm Gap)	WWAN(LTE Band 41 ANT 3) &WIFI 5G U-NII 1	1.332

4. Specific Absorption Rate (SAR)

4.1 Introduction

SAR is related to the rate at which energy is absorbed per unit mass in an object exposed to a radio field. The SAR distribution in a biological body is complicated and is usually carried out by experimental techniques or numerical modeling. The standard recommends limits for two tiers of groups, occupational/controlled and general population/uncontrolled, based on a person's awareness and ability to exercise control over his or her exposure. In general, occupational/controlled exposure limits are higher than the limits for general population/uncontrolled.

The SAR definition is the time derivative (rate) of the incremental energy (dW) absorbed by (dissipated in) an incremental mass (dm) contained in a volume element (dv) of a given density (ρ). The equation description is as below:

$$\text{SAR} = \frac{d}{dt} \left(\frac{dW}{dm} \right) = \frac{d}{dt} \left(\frac{dW}{\rho dv} \right)$$

SAR is expressed in units of Watts per kilogram (W/kg)

SAR measurement can be either related to the temperature elevation in tissue by

$$\text{SAR} = C \frac{\delta T}{\delta t}$$

where C is the specific heat capacity, δT is the temperature rise and δt the exposure duration, or related to the electrical field in the tissue by

$$\text{SAR} = \frac{\sigma |E|^2}{\rho}$$

where σ is the conductivity of the tissue, ρ is the mass density of the tissue and E is the rms electrical field strength.

However for evaluating SAR of low power transmitter, electrical field measurement is typically applied.



4.2 Applicable Standards and Limits

4.2.1 Applicable Standards

47CFR §2.1093	Radiofrequency Radiation Exposure Evaluation: Portable Devices
ANSI C95.1-1992	Safety Levels with Respect to Human Exposure to Radio Frequency Electromagnetic Fields, 3 kHz – 300 GHz.(IEEE Std C95.1-1991)
IEEE 1528-2013	IEEE Recommended Practice for Determining the Peak Spatial-Average Specific Absorption Rate (SAR) in the Human Head from Wireless Communications Devices: Measurement Techniques
KDB 248227 D01	v02r02 802.11 Wi-Fi SAR
KDB 447498 D01	v06 General RF Exposure Guidance
KDB 616217 D04	v01r02 SAR for laptop and tablets
KDB 648474 D04	v01r03 Handset SAR
KDB 865664 D01	v01r04 SAR Measurement 100MHz to 6GHz
KDB 865664 D02	v01r02 SAR Exposure Reporting
KDB 941225 D01	v03r01 3G SAR Procedures
KDB 941225 D05	v02r05 SAR for LTE Devices
KDB 941225 D05A	v01r02 LTE Rel.10 KDB Inquiry Sheet
KDB 941225 D06	v02r01 Hotspot Mode

4.2.2 RF exposure Limits

Human Exposure	Uncontrolled Environment General Population
Spatial Peak SAR* (Brain/Body)	1.60 mW/g
Spatial Average SAR** (Whole Body)	0.08 mW/g
Spatial Peak SAR*** (Limbs)	4.00 mW/g

The limit applied in this test report is shown in bold letters.

Notes:

* The Spatial Peak value of the SAR averaged over any 1 grams of tissue (defined as a tissue volume in the shape of a cube) and over the appropriate averaging time

** The Spatial Average value of the SAR averaged over the whole body.

*** The Spatial Peak value of the SAR averaged over any 10 grams of tissue (defined as a tissue volume in the shape of a cube) and over the appropriate averaging time.

4.3 Phantoms

The phantom used for all tests i.e. for both system checks and device testing, was the twin-headed "SAM Phantom", manufactured by SATIMO. The SAM twin phantom is a fiberglass shell phantom with 2mm shell thickness (except the ear region, where shell thickness increases to 6mm).

System checking was performed using the flat section, whilst Head SAR tests used the left and right head profile sections. Body SAR testing also used the flat section between the head profiles.



SAM Twin Phantom

4.4 Device Holder

The device was placed in the device holder (illustrated below) that is supplied by SATIMO as an integral part of the COMOSAR test system.

The device holder is designed to cope with the different positions given in the standard. It has two scales for device rotation (with respect to the body axis) and device inclination (with respect to the line between the ear reference points). The rotation centers for both scales is the ear reference point (ERP). Thus the device needs no repositioning when changing the angles.

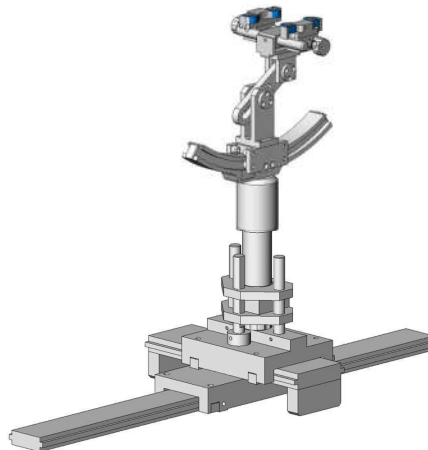

Device holder

4.5 Probe Specification



Construction	Symmetrical design with triangular core Interleaved sensors Built-in shielding against static charges PEEK enclosure material (resistant to organic solvents, e.g., DGBE)
Calibration	ISO/IEC 17025 calibration service available.
Frequency	700 MHz to 3 GHz; Linearity: ± 0.5 dB (700 MHz to 3 GHz)
Directivity	± 0.25 dB in HSL (rotation around probe axis) ± 0.5 dB in tissue material (rotation normal to probe axis)
Dynamic Range	1.5 μ W/g to 100 mW/g; Linearity: ± 0.5 dB
Dimensions	Overall length: 330 mm (Tip: 20 mm) Tip diameter: 5 mm Distance from probe tip to dipole centers: <2.7 mm
Application	General dosimetry up to 3 GHz Dosimetry in strong gradient fields Compliance tests of mobile phones
Compatibility	COMOSAR

Isotropic E-Field Probe

The isotropic E-Field probe has been fully calibrated and assessed for isotropicity, and boundary effect within a controlled environment. Depending on the frequency for which the probe is calibrated the method utilized for calibration will change.

The E-Field probe utilizes a triangular sensor arrangement as detailed in the diagram below:

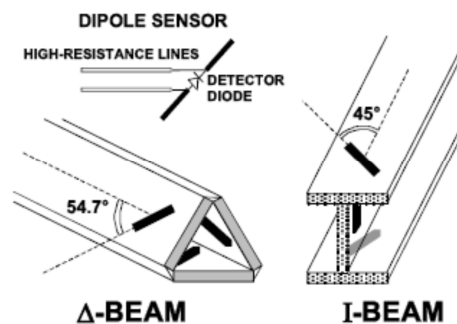

5. Tissue check and recommend Dielectric Parameters

5.1 Tissue Dielectric Parameters for Head and Body Phantoms

The head tissue dielectric parameters recommended by the IEEE SCC-34/SC-2 in P1528 have been incorporated in the following table. These head parameters are derived from planar layer models simulating the highest expected SAR for the dielectric properties and tissue thickness Power drifts in a human head. Other head and body tissue parameters that have not been specified in P1528 are derived from the tissue dielectric parameters computed from the 4-Cole-Cole equations described in Reference [12] and extrapolated according to the head parameters specified in P1528.

Table 1: Recommended Dielectric Performance of Tissue

Ingredients (% by weight)	Frequency (MHz)											
	450		835		915		1900		2450		2600	
Tissue Type	Head	Body	Head	Body	Head	Body	Head	Body	Head	Body	Head	Body
Water	38.56	51.16	41.46	52.4	41.05	56.0	54.9	40.4	62.7	73.2	55.24	64.49
Salt (NaCl)	3.95	1.49	1.45	1.4	1.35	0.76	0.18	0.5	0.5	0.04	0.5	0.024
Sugar	56.32	46.78	56.0	45.0	56.5	41.76	0.0	58.0	0.0	0.0	0.0	0.0
HEC	0.98	0.52	1.0	1.0	1.0	1.21	0.0	1.0	0.0	0.0	0.0	0.0
Bactericide	0.19	0.05	0.1	0.1	0.1	0.27	0.0	0.1	0.0	0.0	0.0	0.0
Triton x-100	0.0	0.0	0.0	0.0	0.0	0.0	0.0	0.0	36.8	0.0	44.45	32.25
DGBE	0.0	0.0	0.0	0.0	0.0	0.0	44.92	0.0	0.0	26.7	0.0	26.7
Dielectric Constant	43.42	58.0	42.54	56.1	42.0	56.8	39.9	54.0	39.2	52.5	39.0	52.5
Conductivity (s/m)	0.85	0.83	0.91	0.95	1.0	1.07	1.42	1.45	1.80	1.78	1.96	2.16

MSL/HSL750 (Body and Head liquid for 650 – 850 MHz)

Item	Head Tissue Simulation Liquid HSL750 Muscle(body)Tissue Simulation Liquid MSL750			
H2O	Water, 35 – 58%			
Sucrose	Sugar, white, refined, 40-60%			
NaCl	Sodium Chloride, 0-6%			
Hydroxyethyl-cellulose	Medium Viscosity (CAS# 9004-62-0), <0.3%			
Preventol-D7	Preservative: aqueous preparation, (CAS# 55965-84-9), containing 5-chloro-2-methyl-3(2H)-isothiazolone and 2-methyl-3(2H)-isothiazolone, 0.1-0.7%			
Frequency (MHz)	Head ϵ_r	Head σ (S/m)	Body ϵ_r	Body σ (S/m)
750	41.9	0.89	55.2	0.97

Note: The liquid of 700MHz&2600MHz typical liquid composition is provided by SATIMO.



Frequency:5200/5400/5600/5800MHz	
Ingredients	(% by weight)
Water	78
Mineral oil	11
Emulsifiers	9
Additives and Salt	2

Table 2 Recommended Tissue Dielectric Parameters

Frequency (MHz)	Head Tissue		Body Tissue	
	ϵ_r	σ (S/m)	ϵ_r	σ (S/m)
150	52.3	0.76	61.9	0.80
300	45.3	0.87	58.2	0.92
450	43.5	0.87	56.7	0.94
835	41.5	0.90	55.2	0.97
900	41.5	0.97	55.0	1.05
915	41.5	0.98	55.0	1.06
1450	40.5	1.20	54.0	1.30
1610	40.3	1.29	53.8	1.40
1800-2000	40.0	1.40	53.3	1.52
2450	39.2	1.80	52.7	1.95
3000	38.5	2.40	52.0	2.73
5800	35.3	5.27	48.2	6.00



5.2 Simulate liquid

Liquid check results:

Table 3: Dielectric Performance of Tissue Simulating Liquid

/	Frequency	Permittivity ϵ	Conductivity σ (S/m)	Liquid Temp. (°C)	Test Date
Target value	750MHz	41.9±5% (39.805~43.995)	0.89±5% (0.8455~0.9345)	22.1	2023/08/17
Validation value		41.12	0.90		
Target value	835MHz	41.5±5% (39.425~43.575)	0.90±5% (0.855~0.945)	22.5	2023/08/08
Validation value		40.87	0.89		
Target value	1800MHz	40.0±5% (38.0~42.0)	1.40±5% (1.33~1.47)	22.2	2023/08/10
Validation value		40.49	1.39		
Target value	1900MHz	40.0±5% (38.0~42.0)	1.40±5% (1.33~1.47)	22.0	2023/08/12
Validation value		39.72	1.41		
Target value	2450MHz	39.2±5% (37.24~41.16)	1.80±5% (1.71~1.89)	22.3	2023/08/03
Validation value		38.74	1.85		
Target value	2600MHz	39.0±5% (37.05~40.95)	1.96±5% (1.862~2.058)	22.4	2023/08/15
Validation value		39.34	1.89		
Target value	5200MHz	36.0±5% (34.20~37.80)	4.66±5% (4.427~4.893)	22.3	2023/08/13
Validation value		35.67	4.61		
Target value	5800MHz	35.3±5% (33.535~37.065)	5.27±5% (5.0065~5.5335)	22.0	2023/08/14
Validation value		34.42	5.29		

SAR System validation

Prior to the assessment, the system validation kit was used to test whether the system was operating within its specifications of $\pm 10\%$. The validation results are tabulated below. And also the corresponding SAR plot is attached as well in the SAR plots files.

The following procedure, recommended for performing validation tests using box phantoms is based on the procedures described in the IEEE standard P1528. Setup according to the setup diagram below:

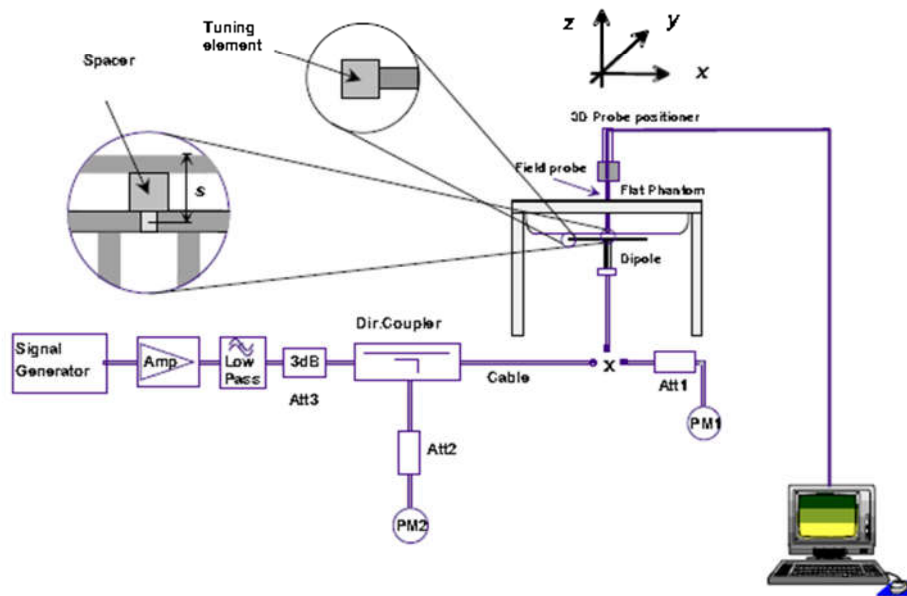

With the SG and Amp and with directional coupler in place, set up the source signal at the relevant frequency and use a power meter to measure the power at the end of the SMA cable that you intend to connect to the balanced dipole. Adjust the SG to make this, say, 0.01W (10 dBm). If this level is too high to read directly with the power meter sensor, insert a calibrated attenuator (e.g. 10 or 20 dB) and make a suitable correction to the power meter reading.

Note 1: In this method, the directional coupler is used for monitoring rather than setting the exact feed power level. If, however, the directional coupler is used for power measurement, you should check the frequency range and power rating of the coupler and measure the coupling factor (referred to output) at the test frequency using a VNA.

Note 2: Remember that the use of a 3dB attenuator (as shown in Figure 8.1 of P1528) means that you need an RF amplifier of 2 times greater power for the same feed power. The other issue is the cable length. You might get up to 1dB of loss per meter of cable, so the cable length after the coupler needs to be quite short.

Note 3: For the validation testing done using CW signals, most power meters are suitable. However, if you are measuring the output of a modulated signal from either a signal generator or a handset, you must ensure that the power meter correctly reads the modulated signals.

The measured 1-gram averaged SAR values of the device against the phantom are provided in Tables 5 and Table 6. The body phantom were full of the body tissue simulating liquid. The EUT was supplied with full-charged battery for each measurement.

The distance between the back of the EUT and the bottom of the flat phantom is 10 mm (taking into account of the IEEE 1528 and the place of the antenna).

Table 4: system validation (1g)
System Check Results

Frequency	Duty cycle	Target value (1-g) (W/Kg)	10mW Test value (1-g) (W/Kg)	Test SAR Normalized to 1W(w/Kg)	Test Date
750MHz	1:1	8.65 W/kg±10% (7.785~9.515)	0.0858	8.58	2023/08/17
835MHz	1:1	9.93 W/kg±10% (8.937~10.923)	0.1008	1.008	2023/08/08
1800MHz	1:1	37.81 W/kg±10% (34.029~41.591)	0.3677	36.77	2023/08/10
1900MHz	1:1	41.50 W/kg±10% (37.350~45.650)	0.4163	41.63	2023/08/12
2450MHz	1:1	51.74 W/kg±10% (46.566~56.914)	0.4981	49.81	2023/08/03
2600MHz	1:1	57.13 W/kg±10% (51.417~62.843)	0.5389	53.89	2023/08/15
5200MHz	1:1	152.95 W/kg±10% (137.655~168.245)	1.6487	164.87	2023/08/13
5800MHz	1:1	174.67 W/kg±10% (157.203~192.137)	1.8400	184.00	2023/08/14

Note:

1. Target value was referring to the measured value in the calibration certificate of reference dipole.
2. All SAR values are normalized to 1W forward power.

6. SAR measurement procedure

The SAR test against the head phantom was carried out as follow:

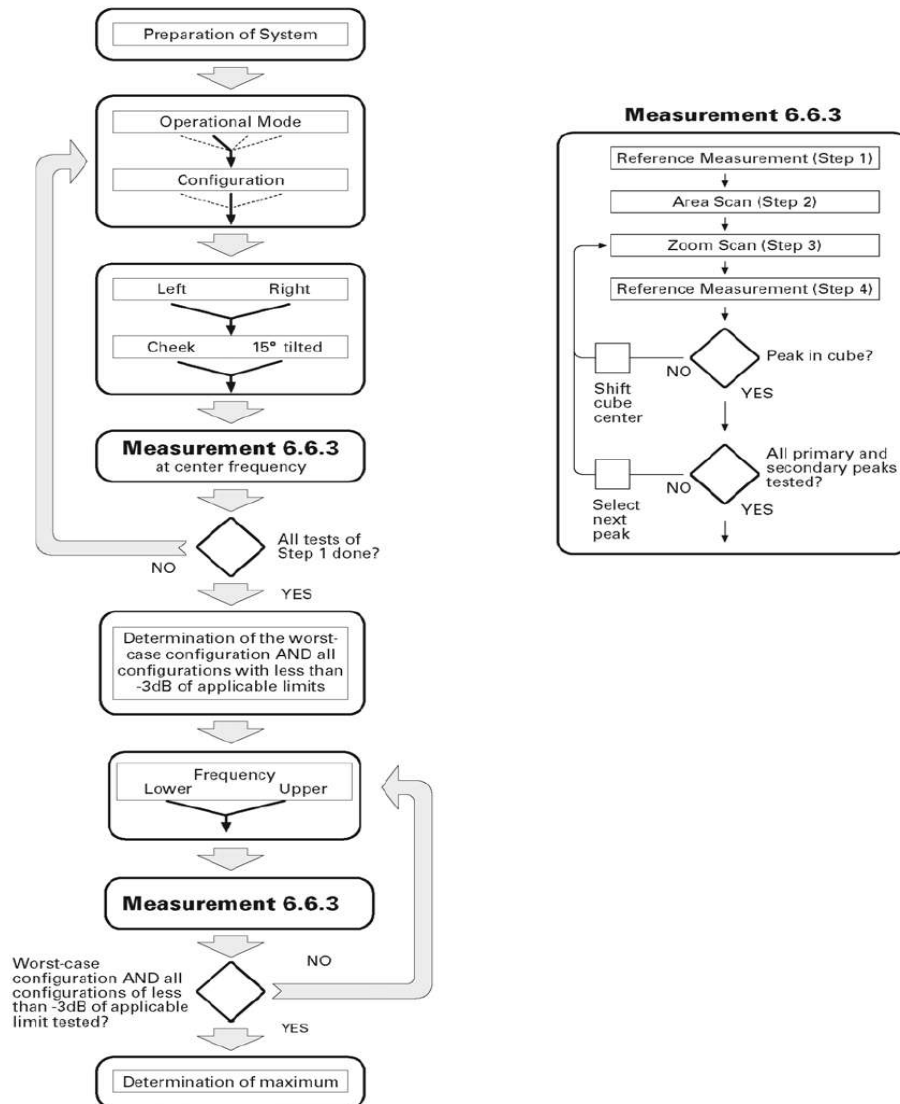

Establish a call with the maximum output power with a base station simulator, the connection between the EUT and the base station simulator is established via air interface.

After an area scan has been done at a fixed distance of 2mm from the surface of the phantom on the source side, a 3D scan is set up around the location of the maximum spot SAR. First, a point within the scan area is visited by the probe and a SAR reading taken at the start of testing. At the end of testing, the probe is returned to the same point and a second reading is taken. Comparison between these start and end readings enables the power drift during measurement to be assessed.

Above is the scanning procedure flow chart and table from the IEEE p1528 standard. This is the procedure for which all compliant testing should be carried out to ensure that all variations of the device position and transmission behavior are tested.



7. Conducted RF Output Power

7.1 GSM Conducted Power

GSM850 ANT 3		Burst-Averaged output Power (dBm)			Division Factors	Frame-Averaged output Power (dBm)		
		128CH	190CH	251CH		128CH	190CH	251CH
		824.2	836.6	848.8		824.2	836.6	848.8
GSM (CS)		31.75	31.80	31.81	-9.03	22.72	22.77	22.78
GPRS (GMSK)	1 Tx Slot	31.81	31.84	31.79	-9.03	22.78	22.81	22.76
	2 Tx Slots	31.01	31.05	31.05	-6.02	24.99	25.03	25.03
	3 Tx Slots	29.31	29.31	29.29	-4.26	25.05	25.05	25.03
	4 Tx Slots	28.26	28.25	28.22	-3.01	25.25	25.24	25.21
EDGE (8PSK)	1 Tx Slot	25.34	25.36	25.28	-9.03	16.31	16.33	16.25
	2 Tx Slots	24.18	24.18	24.09	-6.02	18.16	18.16	18.07
	3 Tx Slots	22.20	22.13	22.11	-4.26	17.94	17.87	17.85
	4 Tx Slots	21.09	21.08	21.02	-3.01	18.08	18.07	18.01
GSM1900 ANT 3		Burst-Averaged output Power (dBm)			Division Factors	Frame-Averaged output Power (dBm)		
		512CH	661CH	810CH		512CH	661CH	810CH
		1850.2	1880.0	1909.8		1850.2	1880.0	1909.8
GSM (CS)		29.04	28.97	28.69	-9.03	20.01	19.94	19.66
GPRS (GMSK)	1 Tx Slot	29.03	28.93	28.70	-9.03	20.00	19.90	19.67
	2 Tx Slots	28.44	28.31	27.93	-6.02	22.42	22.29	21.91
	3 Tx Slots	26.74	26.58	26.22	-4.26	22.48	22.32	21.96
	4 Tx Slots	25.71	25.53	25.16	-3.01	22.70	22.52	22.15
EDGE (8PSK)	1 Tx Slot	25.39	25.31	25.20	-9.03	16.36	16.28	16.17
	2 Tx Slots	23.94	23.97	23.80	-6.02	17.92	17.95	17.78
	3 Tx Slots	21.60	21.72	21.58	-4.26	17.34	17.46	17.32
	4 Tx Slots	20.25	20.28	20.15	-3.01	17.24	17.27	17.14

Note:

1. Per KDB 447498 D01 v06, the maximum output power channel is used for SAR testing and for further SAR test reduction.
2. For hotspot SAR, EUT was performed at GPRS Class 12 multi-slots(4Tx) mode.
3. For Head and Body-worn SAR testing, EUT was set in GSM Voice mode for both GSM850 and GSM1900.

Timeslot consignations

No. Of Slots	Slot 1	Slot 2	Slot 3	Slot 4
Slot Consignation	1Up4Down	2UpDown	3UpDown	4Up1Down
Duty Cycle	1:8	1:4	1:2.67	1:2
Crest Factor	-9.03dB	-6.02dB	-4.26dB	-3.01dB



7.2 WCDMA Conducted output Power

UMTS850 (Band V) ANT 3		Averaged output Power (dBm)		
		4132CH	4183CH	4233CH
		826.4	836.6	846..6
WCDMA	12.2kbps RMC	22.00	21.85	21.74
HSDPA	Subtest 1	21.65	21.61	21.66
	Subtest 2	21.28	21.14	21.11
	Subtest 3	21.80	21.56	21.50
	Subtest 4	21.70	21.78	21.58
HSUPA	Subtest 1	21.72	21.67	21.45
	Subtest 2	20.36	20.25	20.19
	Subtest 3	20.85	20.64	20.79
	Subtest 4	21.06	20.88	20.91
	Subtest 5	20.37	20.15	20.16
UMTS1700 (Band IV) ANT 3		Averaged output Power (dBm)		
		1312CH	1413CH	1513CH
		882.4	897.6	912.6
WCDMA	12.2kbps RMC	21.25	21.20	21.11
HSDPA	Subtest 1	21.15	21.11	21.06
	Subtest 2	20.78	20.64	20.61
	Subtest 3	21.10	21.06	21.00
	Subtest 4	21.20	21.18	21.08
HSUPA	Subtest 1	21.22	21.17	21.05
	Subtest 2	19.86	19.75	19.69
	Subtest 3	20.25	20.14	20.09
	Subtest 4	20.56	20.48	20.41
	Subtest 5	19.87	19.75	19.66
UMTS1900 (Band II) ANT 3		Averaged output Power (dBm)		
		9262CH	9400CH	9538cH
		1852.4	1880.0	1907.6
WCDMA	12.2kbps RMC	20.74	20.52	20.61
HSDPA	Subtest 1	20.65	20.31	20.56
	Subtest 2	20.28	19.84	20.11
	Subtest 3	20.61	20.27	20.51
	Subtest 4	20.70	20.38	20.57
HSUPA	Subtest 1	20.71	20.37	20.56
	Subtest 2	19.36	18.94	19.19
	Subtest 3	19.75	19.34	19.59
	Subtest 4	20.08	19.68	19.91
	Subtest 5	19.38	18.96	19.16

Note:

1. WCDMA SAR was tested under RMC 12.2kbps with HSPA Inactive per KDB Publication 941225 D01v03r01.HSPA SAR was not requires since the average output power of the HSPA



subtests was not more than 0.25dB higher than the RMC level and SAR was less than 1.2W/kg.

2. It is expected by the manufacturer that MPR for some HSPA subtests may be up to 2dB more than specified by 3GPP, but also as low as 0dB according to the chipset implementation in this model

7.3 LTE Conducted peak output Power

LTE Test Configurations

The CMW500 Wide Band Radio Communication Tester was used for LTE output power measurements and SAR testing. Closed loop power control was used so the UE transmits with maximum output power during SAR testing. SAR test were performed with the same number of RB and RB offsets transmitting on all frames.

1) Spectrum Plots for RB configurations

A properly configured base station simulator was used for LTE output power measurements and SAR testing. Therefore, spectrum plots for RB configurations were not required to be included in this report.

2) MPR

When MPR is implemented permanently within the UE, regardless of network requirements, only those RB configurations allowed by 3GPP for the channel bandwidth and modulation combinations may be tested with MPR active. Configurations with RB allocations less than the RB thresholds required by 3GPP must be tested without MPR.

The allowed Maximum Power Reduction(MPR) for the maximum output power due to higher order modulation and transmit bandwidth configuration (resource blocks) is specified in Table 6.2.3-1 of the 3GPP TS36.101:

Table 6.2.3-1: Maximum Power Reduction (MPR) for Power Class 3

Modulation	Channel bandwidth / Transmission bandwidth configuration [RB]						MPR (dB)
	1.4 MHz	3.0 MHz	5 MHz	10 MHz	15 MHz	20 MHz	
QPSK	> 5	> 4	> 8	> 12	> 16	> 18	≤ 1
16 QAM	≤ 5	≤ 4	≤ 8	≤ 12	≤ 16	≤ 18	≤ 1
16 QAM	> 5	> 4	> 8	> 12	> 16	> 18	≤ 2

3) A-MPR LTE procedures for SAR testing

A-MPR(Additional MPR) has been disabled for all SAR tests by using Network Signaling Value of “NS_01” on the base station simulator.

4) LTE procedures for SAR testing

A) Largest channel bandwidth standalone SAR test

requirements i) QPSK with 1 RB allocation

Start with the largest channel bandwidth and measure SAR for QPSK with 1 RB allocation, using the RB offset and required test channel combination with the highest maximum output power for RB offsets at the upper edge, middle and lower edge of each required test channel. When the reported SAR is $\leq 0.8\text{W/kg}$, testing of the remaining RB offset configurations and required test channels is not required for 1RB allocation; otherwise, SAR is required for the remaining required test channels and only for the RB offset configuration with the highest output power for that channel. When the reported SAR of a required test channel is $> 1.45\text{W/kg}$, SAR is required for all three RB offset configurations for that required test channel.



1. LTE Band 2 Conducted Power Test Verdict:

LTE FDD Band 2 ANT 3				Conducted Power(dBm)			Tune up
Bandwidth	Modulation	RB size	RB offset	Channel/Frequency			
				18607/1850.7	18900/1880.0	19193/1909.3	
1.4MHz	QPSK	1	0	22.32	22.40	22.34	22.0±1.0
		1	3	22.45	22.25	22.51	
		1	5	22.35	22.12	22.40	
		3	0	21.40	21.36	21.41	21.0±1.0
		3	2	21.41	21.25	21.39	
		3	3	21.38	21.29	21.38	
		6	0	21.34	21.22	21.31	21.0±1.0
	16QAM	1	0	21.33	21.31	21.30	21.0±1.0
		1	3	21.43	21.47	21.56	
		1	5	21.30	21.22	21.38	
		3	0	20.55	20.25	20.59	20.0±1.0
		3	2	20.51	20.34	20.50	
		3	3	20.51	20.20	20.56	
		6	0	20.34	20.17	20.39	20.0±1.0
Bandwidth	Modulation	RB size	RB offset	Channel/Frequency			Tune up
				18615/1851.5	18900/1880.0	19185/1908.5	
3MHz	QPSK	1	0	22.36	22.29	22.31	22.0±1.0
		1	7	22.49	22.27	22.23	
		1	14	22.22	22.13	22.27	
		8	0	21.31	21.13	21.25	21.0±1.0
		8	4	21.42	21.21	21.24	
		8	7	21.25	21.27	21.17	
		15	0	21.20	21.15	21.10	21.0±1.0
	16QAM	1	0	21.44	21.37	21.69	21.0±1.0
		1	7	21.77	21.51	21.67	
		1	14	21.32	21.29	21.71	
		8	0	20.39	20.28	20.29	20.0±1.0
		8	4	20.25	20.24	20.30	
		8	7	20.15	20.20	20.31	
		15	0	20.10	20.21	20.18	20.0±1.0



LTE FDD Band 2 ANT 3				Conducted Power(dBm)			
Bandwidth	Modulation	RB size	RB offset	Channel/Frequency			Tune up
				18625/1852.5	18900/1880.0	19175/1907.5	
5MHz	QPSK	1	0	22.29	22.36	22.10	22.0±1.0
		1	13	22.35	22.25	22.23	
		1	24	22.31	22.19	22.12	
		12	0	21.28	21.12	21.07	21.0±1.0
		12	6	21.30	21.10	21.10	
		12	13	21.24	21.16	21.17	
	25	0	21.25	21.12	21.10	21.0±1.0	
	16QAM	1	0	21.46	21.26	21.18	21.0±1.0
		1	13	21.53	21.37	21.21	
		1	24	21.42	21.22	21.20	
		12	0	20.29	20.21	20.23	20.0±1.0
		12	6	20.28	20.19	20.25	
		12	13	20.27	20.13	20.16	
		25	0	20.17	20.15	20.15	20.0±1.0
Bandwidth	Modulation	RB size	RB offset	Channel/Frequency			Tune up
				18650/1855.0	18900/1880.0	19150/1905.0	
10MHz	QPSK	1	0	22.33	22.21	22.25	22.0±1.0
		1	25	22.47	22.37	22.40	
		1	49	22.27	22.12	22.37	
		25	0	21.37	21.19	21.16	21.0±1.0
		25	13	21.34	21.20	21.18	
		25	25	21.22	21.22	21.36	
		50	0	21.25	21.18	21.26	21.0±1.0
	16QAM	1	0	21.45	21.36	21.21	21.0±1.0
		1	25	21.51	21.43	21.26	
		1	49	21.34	21.26	21.29	
		25	0	20.40	20.23	20.22	20.0±1.0
		25	13	20.40	20.23	20.25	
		25	25	20.27	20.27	20.41	
		50	0	20.31	20.20	20.26	20.0±1.0



LTE FDD Band 2 ANT 3				Conducted Power(dBm)			
Bandwidth	Modulation	RB size	RB offset	Channel/Frequency			Tune up
				18675/1857.5	18900/1880.0	19125/1902.5	
15MHz	QPSK	1	0	22.24	22.12	22.17	22.0±1.0
		1	38	22.30	22.17	22.20	
		1	74	22.11	22.07	22.12	
		36	0	21.78	21.38	20.96	21.0±1.0
		36	18	21.78	21.39	20.95	
		36	39	21.64	21.32	20.96	
		75	0	21.33	21.32	20.98	21.0±1.0
	16QAM	1	0	21.79	21.38	21.36	21.0±1.0
		1	38	21.76	21.48	21.56	
		1	74	21.62	21.36	21.39	
		36	0	20.68	20.36	20.35	20.0±1.0
		36	18	20.67	20.39	20.24	
		36	39	20.51	20.44	20.37	
		75	0	20.31	20.31	20.28	20.0±1.0
Bandwidth	Modulation	RB size	RB offset	Channel/Frequency			Tune up
				18700/1860.0	18900/1880.0	19100/1900.0	
20MHz	QPSK	1	0	22.43	22.33	22.39	22.0±1.0
		1	50	22.46	22.34	22.29	
		1	99	22.22	22.18	22.15	
		50	0	21.34	21.12	21.23	21.0±1.0
		50	25	21.36	21.11	21.24	
		50	50	21.15	21.16	21.37	
		100	0	21.27	21.15	21.29	21.0±1.0
	16QAM	1	0	21.40	21.30	21.20	21.0±1.0
		1	50	21.63	21.58	21.59	
		1	99	21.31	21.18	21.22	
		50	0	20.39	20.31	20.21	20.0±1.0
		50	25	20.40	20.18	20.23	
		50	50	20.15	20.25	20.31	
		100	0	20.29	20.21	20.29	20.0±1.0



2. LTE Band 4 Conducted Power Test Verdict:

LTE FDD Band 4 ANT 3				Conducted Power(dBm)			Tune up
Bandwidth	Modulation	RB size	RB offset	Channel/Frequency			
				19957/1710.7	20175/1732.5	20393/1754.3	
1.4MHz	QPSK	1	0	22.77	22.73	22.89	22.5±1.0
		1	3	22.97	22.89	23.04	
		1	5	22.65	22.74	22.91	
		3	0	21.84	21.82	21.98	21.5±1.0
		3	2	21.81	21.82	21.96	
		3	3	21.85	21.85	21.93	
		6	0	21.80	21.74	21.87	21.5±1.0
	16QAM	1	0	21.74	21.84	22.00	21.5±1.0
		1	3	21.94	22.04	22.18	
		1	5	22.98	21.85	22.01	
		3	0	20.88	20.84	20.88	20.5±1.0
		3	2	20.87	20.79	20.89	
		3	3	20.84	20.81	20.88	
		6	0	20.77	20.73	20.83	20.5±1.0
Bandwidth	Modulation	RB size	RB offset	Channel/Frequency			Tune up
3MHz	QPSK	1	0	23.01	22.77	22.73	22.5±1.0
		1	7	23.01	22.84	22.78	
		1	14	23.01	22.73	22.78	
		8	0	21.99	21.76	21.79	21.5±1.0
		8	4	21.98	21.76	21.78	
		8	7	21.99	21.77	21.76	
		15	0	21.87	21.72	21.74	21.5±1.0
	16QAM	1	0	22.16	22.01	21.91	21.5±1.0
		1	7	22.12	22.14	21.86	
		1	14	22.13	21.99	21.87	
		8	0	20.96	20.73	20.75	20.5±1.0
		8	4	20.95	20.81	20.77	
		8	7	20.94	20.70	20.74	
		15	0	20.92	20.77	20.66	20.5±1.0



LTE FDD Band 4 ANT 3				Conducted Power(dBm)			
Bandwidth	Modulation	RB size	RB offset	Channel/Frequency			Tune up
				19975/1712.5	20175/1732.5	20375/1752.5	
5MHz	QPSK	1	0	22.78	22.75	22.62	22.5±1.0
		1	13	22.91	22.85	22.77	
		1	24	22.76	22.71	22.65	
		12	0	21.81	21.76	21.69	21.5±1.0
		12	6	21.84	21.76	21.69	
		12	13	21.82	21.78	21.74	
		25	0	21.82	21.79	21.68	21.5±1.0
	16QAM	1	0	22.03	22.01	21.72	21.5±1.0
		1	13	22.14	22.11	21.81	
		1	24	22.03	21.94	21.65	
		12	0	20.80	20.75	20.76	20.5±1.0
		12	6	20.92	20.86	20.66	
		12	13	20.82	20.78	20.81	
		25	0	20.81	20.74	20.75	20.5±1.0
Bandwidth	Modulation	RB size	RB offset	Channel/Frequency			Tune up
10MHz	QPSK	1	0	22.83	22.83	22.75	22.5±1.0
		1	25	23.02	22.94	22.90	
		1	49	22.84	22.72	22.68	
		25	0	21.87	21.80	21.80	21.5±1.0
		25	13	21.88	21.79	21.79	
		25	25	21.95	21.83	21.72	
		50	0	21.84	21.76	21.71	21.5±1.0
	16QAM	1	0	22.32	21.92	22.30	22.0±1.0
		1	25	22.51	22.11	22.38	
		1	49	22.31	21.84	22.21	
		25	0	20.90	20.79	20.84	20.5±1.0
		25	13	20.91	20.81	20.85	
		25	25	20.87	20.86	20.78	
		50	0	20.85	20.82	20.80	20.5±1.0



LTE FDD Band 4 ANT 3				Conducted Power(dBm)			
Bandwidth	Modulation	RB size	RB offset	Channel/Frequency			Tune up
				20025/1717.5	20175/1732.5	20325/1747.5	
15MHz	QPSK	1	0	22.77	22.72	22.69	22.5±1.0
		1	38	22.80	22.86	22.78	
		1	74	22.69	22.70	22.61	
		36	0	22.09	22.00	22.02	21.5±1.0
		36	18	21.94	21.98	22.07	
		36	39	22.02	21.97	21.91	
		75	0	21.88	21.95	21.83	21.5±1.0
	16QAM	1	0	22.24	22.00	22.21	22.0±1.0
		1	38	22.31	22.13	22.28	
		1	74	22.23	21.94	22.14	
		36	0	20.94	20.97	21.03	20.5±1.0
		36	18	21.05	20.99	20.96	
		36	39	20.89	20.96	21.12	
		75	0	20.86	20.91	20.81	20.5±1.0
Bandwidth	Modulation	RB size	RB offset	Channel/Frequency			Tune up
				20050/1720.0	20175/1732.5	20300/1745.0	
20MHz	QPSK	1	0	22.86	22.91	22.80	22.5±1.0
		1	50	23.00	22.94	22.97	
		1	99	22.76	22.65	22.89	
		50	0	21.81	21.74	21.75	21.5±1.0
		50	25	21.81	21.74	21.78	
		50	50	21.79	21.80	21.68	
		100	0	21.85	21.80	21.74	21.5±1.0
	16QAM	1	0	21.89	22.14	21.76	21.5±1.0
		1	50	22.03	22.13	22.08	
		1	99	21.84	22.02	21.65	
		50	0	20.79	20.71	20.77	20.5±1.0
		50	25	20.78	20.75	20.85	
		50	50	20.77	20.80	20.70	
		100	0	20.72	20.76	20.74	20.5±1.0



3. LTE Band 5 Conducted Power Test Verdict:

LTE FDD Band 5 ANT 3				Conducted Power(dBm)			Tune up		
Bandwidth	Modulation	RB size	RB offset	Channel/Frequency					
				20407/824.7	20525/836.5	20643/848.3			
1.4MHz	QPSK	1	0	23.53	23.49	23.56	23.0±1.0		
		1	3	23.69	23.68	23.52			
		1	5	23.59	23.50	23.38			
		3	0	22.62	22.52	22.44	22.0±1.0		
		3	2	22.60	22.55	22.42			
		3	3	22.55	22.54	22.43			
	16QAM	16QAM	6	0	22.56	22.48	22.38	22.0±1.0	
			1	0	22.56	22.57	22.45	22.0±1.0	
			1	3	22.71	22.75	22.61		
			1	5	22.61	22.58	22.47		
			21.0±1.0	16QAM	3	0	21.76	21.46	21.35
					3	2	21.76	21.47	21.44
					3	3	21.74	21.53	21.36
					6	0	21.59	21.46	21.41

Bandwidth	Modulation	RB size	RB offset	Channel/Frequency			Tune up		
				20415/825.5	20525/836.5	20635/847.5			
3MHz	QPSK	1	0	23.67	23.39	23.54	23.0±1.0		
		1	7	23.68	23.55	23.55			
		1	14	23.67	23.35	23.53			
		22.0±1.0	QPSK	8	0	22.66	22.47	22.53	
				8	4	22.63	22.48	22.53	
				8	7	22.67	22.41	22.49	
	15			0	22.59	22.38	22.46		
	22.5±1.0	16QAM	1	0	22.78	22.26	22.67		
			1	7	22.80	22.39	22.60		
			1	14	22.77	22.23	22.61		
			21.0±1.0	16QAM	8	0	21.62	21.57	21.48
					8	4	21.63	21.47	21.46
					8	7	21.61	21.54	21.43
			21.0±1.0	16QAM	15	0	21.56	21.52	21.43



LTE FDD Band 5 ANT 3				Conducted Power(dBm)			
Bandwidth	Modulation	RB size	RB offset	Channel/Frequency			Tune up
				20425/826.5	20525/836.5	20625/846.5	
5MHz	QPSK	1	0	23.48	23.39	23.33	23.0±1.0
		1	13	23.62	23.49	23.46	
		1	24	23.50	23.35	23.29	
		12	0	22.51	22.47	22.40	22.0±1.0
		12	6	22.49	22.48	22.40	
		12	13	22.52	22.44	22.38	
	25	0	22.54	22.44	22.40	22.0±1.0	
	16QAM	1	0	22.72	22.33	22.54	22.5±1.0
		1	13	22.86	22.39	22.70	
		1	24	22.73	22.20	22.51	
		12	0	21.46	21.39	21.36	21.0±1.0
		12	6	21.48	21.41	21.48	
		12	13	21.51	21.39	21.35	
		25	0	21.44	21.31	21.38	21.0±1.0
Bandwidth	Modulation	RB size	RB offset	Channel/Frequency			Tune up
10MHz	QPSK	1	0	23.64	23.53	23.51	23.0±1.0
		1	25	23.70	23.64	23.52	
		1	49	23.53	23.44	23.34	
		25	0	22.50	22.53	22.42	22.0±1.0
		25	13	22.51	22.53	22.45	
		25	25	22.54	22.52	22.33	
		50	0	22.45	22.48	22.40	22.0±1.0
	16QAM	1	0	22.85	22.77	22.77	22.5±1.0
		1	25	22.98	22.92	22.79	
		1	49	22.79	22.74	22.62	
		25	0	21.56	21.55	21.47	21.0±1.0
		25	13	21.59	21.51	21.49	
		25	25	21.52	21.54	21.34	
		50	0	21.52	21.45	21.40	21.0±1.0



4. LTE Band 7 Conducted Power Test Verdict:

LTE FDD Band 7 ANT 3				Conducted Power(dBm)			Tune up
Bandwidth	Modulation	RB size	RB offset	Channel/Frequency			
				20775/2502.5	21100/2535.0	21425/2567.5	
5MHz	QPSK	1	0	17.51	17.44	17.49	17.0±1.0
		1	13	17.39	17.32	17.54	
		1	24	17.54	17.21	17.27	
		12	0	16.28	16.19	16.18	16.0±1.0
		12	6	16.21	16.19	16.25	
		12	13	16.32	16.26	16.19	
		25	0	16.25	16.22	16.08	16.0±1.0
	16QAM	1	0	16.45	16.39	16.15	16.0±1.0
		1	13	16.58	16.53	16.25	
		1	24	16.34	16.37	16.27	
		12	0	15.15	15.28	15.22	15.0±1.0
		12	6	15.29	15.39	15.36	
		12	13	15.20	15.24	15.17	
		25	0	15.18	15.23	15.18	14.5±1.0
Bandwidth	Modulation	RB size	RB offset	Channel/Frequency			Tune up
				20800/2505.0	21100/2535.0	21400/2565.0	
10MHz	QPSK	1	0	17.38	17.29	17.45	17.0±1.0
		1	25	17.33	17.43	17.38	
		1	49	17.24	17.34	17.27	
		25	0	16.18	16.29	16.24	16.0±1.0
		25	13	16.17	16.29	16.24	
		25	25	16.22	16.32	16.11	
		50	0	16.21	16.30	16.16	16.0±1.0
	16QAM	1	0	16.32	16.20	16.19	16.0±1.0
		1	25	16.49	16.31	16.30	
		1	49	16.38	16.32	16.11	
		25	0	15.22	15.33	15.30	15.0±1.0
		25	13	15.20	15.33	15.32	
		25	25	15.27	15.40	15.15	
		50	0	15.22	15.30	15.19	15.0±1.0



LTE FDD Band 7 ANT 3				Conducted Power(dBm)			
Bandwidth	Modulation	RB size	RB offset	Channel/Frequency			Tune up
				20825/2507.5	21100/2535.0	21375/2562.5	
15MHz	QPSK	1	0	17.32	17.28	17.36	17.0±1.0
		1	38	17.25	17.24	17.19	
		1	74	17.13	17.16	17.28	
		36	0	16.36	16.07	16.11	16.0±1.0
		36	18	16.14	15.99	16.24	
		36	39	16.29	16.17	16.08	
		75	0	16.24	16.01	16.11	15.5±1.0
	16QAM	1	0	16.12	16.01	16.07	15.5±1.0
		1	38	16.21	16.11	16.17	
		1	74	16.16	16.01	17.24	
		36	0	15.28	15.98	16.06	15.5±1.0
		36	18	15.15	16.12	16.17	
		36	39	15.22	16.11	16.12	
		75	0	15.13	16.01	16.01	15.5±1.0
Bandwidth	Modulation	RB size	RB offset	Channel/Frequency			Tune up
				20850/2510	21100/2535.0	21350/2560	
20MHz	QPSK	1	0	17.38	17.34	17.41	17.0±1.0
		1	50	17.31	17.44	17.57	
		1	99	17.20	17.27	17.29	
		50	0	16.10	16.19	16.12	16.0±1.0
		50	25	16.09	16.22	16.14	
		50	50	16.02	16.23	16.01	
		100	0	15.94	16.11	16.08	15.5±1.0
	16QAM	1	0	16.20	16.20	16.12	16.0±1.0
		1	50	16.19	16.33	16.39	
		1	99	16.21	16.21	16.15	
		50	0	15.03	15.19	15.10	14.5±1.0
		50	25	15.19	15.21	15.12	
		50	50	15.17	15.23	15.04	
		100	0	15.13	15.12	15.02	14.5±1.0



5. LTE Band 12 Conducted Power Test Verdict:

LTE FDD Band 12 ANT 3				Conducted Power(dBm)			
Bandwidth	Modulation	RB size	RB offset	Channel/Frequency			Tune up
				23017/699.7	23095/707.5	23173/715.3	
1.4MHz	QPSK	1	0	22.92	22.77	22.94	22.5±1.0
		1	3	23.09	22.92	23.11	
		1	5	22.96	22.79	22.95	
		3	0	22.04	21.94	22.03	21.5±1.0
		3	2	22.17	21.96	22.02	
		3	3	22.11	22.03	21.93	
		6	0	22.12	21.93	21.96	21.5±1.0
	16QAM	1	0	22.09	21.90	21.94	21.5±1.0
		1	3	22.20	22.11	22.17	
		1	5	22.11	21.92	21.99	
		3	0	21.30	21.07	21.16	21.0±1.0
		3	2	21.31	21.08	21.17	
		3	3	21.29	21.01	21.18	
		6	0	21.14	20.92	21.06	20.5±1.0
Bandwidth	Modulation	RB size	RB offset	Channel/Frequency			Tune up
3MHz	QPSK	1	0	22.92	22.80	22.95	22.5±1.0
		1	7	22.93	22.90	22.93	
		1	14	22.98	22.79	22.98	
		8	0	21.97	21.82	22.01	21.5±1.0
		8	4	21.98	21.81	22.03	
		8	7	21.92	21.76	21.94	
		15	0	21.89	21.72	21.95	21.5±1.0
	16QAM	1	0	22.09	22.17	22.10	22.0±1.0
		1	7	22.03	22.34	22.06	
		1	14	22.01	22.16	22.15	
		8	0	21.07	21.07	20.97	20.5±1.0
		8	4	21.04	20.89	20.95	
		8	7	21.01	20.92	20.93	
		15	0	21.02	21.03	20.86	20.5±1.0



LTE FDD Band 12 ANT 3				Conducted Power(dBm)			
Bandwidth	Modulation	RB size	RB offset	Channel/Frequency			Tune up
				23035/701.5	23095/707.5	23155/713.5	
5MHz	QPSK	1	0	22.84	22.83	22.84	22.5±1.0
		1	13	23.00	22.89	22.96	
		1	24	22.80	22.77	22.82	
		12	0	21.92	21.97	22.00	21.5±1.0
		12	6	21.92	21.95	22.00	
		12	13	21.87	22.00	21.85	
		25	0	21.93	21.99	21.93	21.5±1.0
	16QAM	1	0	21.91	22.03	21.87	21.5±1.0
		1	13	22.02	22.16	21.96	
		1	24	21.83	22.07	21.85	
		12	0	20.88	20.97	20.90	20.5±1.0
		12	6	20.92	20.99	20.88	
		12	13	20.82	21.03	20.81	
		25	0	20.95	21.00	20.94	20.5±1.0
Bandwidth	Modulation	RB size	RB offset	Channel/Frequency			Tune up
10MHz	QPSK	1	0	22.83	22.88	22.85	22.5±1.0
		1	25	23.00	22.99	23.00	
		1	49	22.82	22.89	22.89	
		25	0	22.03	22.08	21.88	21.5±1.0
		25	13	22.02	22.04	21.96	
		25	25	21.98	22.14	21.84	
		50	0	22.01	22.07	21.85	21.5±1.0
	16QAM	1	0	22.05	22.07	22.07	21.5±1.0
		1	25	22.16	22.12	22.17	
		1	49	22.09	22.08	21.98	
		25	0	21.06	21.10	20.94	20.5±1.0
		25	13	21.08	21.13	20.92	
		25	25	21.03	21.20	20.86	
		50	0	21.00	21.11	20.86	20.5±1.0



6. LTE Band 13 Conducted Power Test Verdict:

LTE FDD Band 13 ANT 3				Conducted Power(dBm)			Tune up
Bandwidth	Modulation	RB size	RB offset	Channel/Frequency			
				23205/779.5	23230/782.0	23255/784.5	
5MHz	QPSK	1	0	23.28	23.26	23.33	23.0±1.0
		1	13	23.13	23.32	23.37	
		1	24	23.15	23.15	23.39	
		12	0	22.31	22.25	22.33	22.0±1.0
		12	6	22.19	22.21	22.33	
		12	13	22.25	22.29	22.41	
	16QAM	25	0	22.16	22.28	22.32	22.0±1.0
		1	0	22.28	22.12	22.23	22.0±1.0
		1	13	22.38	22.27	22.47	
		1	24	22.20	22.14	22.30	
		21.0±1.0	12	0	21.31	21.32	21.34
			12	6	21.20	21.19	21.29
			12	13	21.28	21.26	21.41
			25	0	21.23	21.32	21.37
21.0±1.0				Channel/Frequency			
				/	23230/782.0	/	
10MHz	QPSK	1	0	/	23.33	/	23.0±1.0
		1	25	/	23.37	/	
		1	49	/	23.39	/	
		22.0±1.0	25	0	/	22.33	/
			25	13	/	22.33	/
			25	25	/	22.41	/
			50	0	/	22.32	/
	22.0±1.0	16QAM	1	0	/	22.23	/
			1	25	/	22.47	/
			1	49	/	22.30	/
		21.0±1.0	25	0	/	21.34	/
			25	13	/	21.29	/
			25	25	/	21.49	/
			50	0	/	21.30	/
21.0±1.0				Channel/Frequency			
			/	23230/782.0	/		



7. LTE Band 17 Conducted Power Test Verdict:

LTE FDD Band 17 ANT 3				Conducted Power(dBm)			Tune up
Bandwidth	Modulation	RB size	RB offset	Channel/Frequency			
				23755/706.5	23790/710.0	23825/713.5	
5MHz	QPSK	1	0	23.17	23.06	23.10	22.5±1.0
		1	13	23.22	22.91	22.97	
		1	24	23.16	22.82	22.83	
		12	0	22.15	21.90	21.95	21.5±1.0
		12	6	22.19	21.90	21.92	
		12	13	22.21	22.00	21.89	
		25	0	22.18	21.98	21.92	21.5±1.0
	16QAM	1	0	22.05	22.21	22.18	22.0±1.0
		1	13	22.21	22.33	22.23	
		1	24	22.16	22.11	22.14	
		12	0	21.21	20.92	20.93	21.0±1.0
		12	6	21.22	21.03	21.04	
		12	13	21.28	21.12	20.83	
		25	0	21.33	20.98	20.91	21.0±1.0
Bandwidth	Modulation	RB size	RB offset	Channel/Frequency			Tune up
10MHz	QPSK	1	0	22.88	22.99	23.06	22.5±1.0
		1	25	23.07	22.94	22.99	
		1	49	22.90	23.01	22.87	
		25	0	22.01	22.00	21.87	21.5±1.0
		25	13	22.02	21.92	21.80	
		25	25	22.09	22.06	21.84	
		50	0	22.00	21.96	21.78	21.5±1.0
	16QAM	1	0	22.07	22.10	22.09	21.5±1.0
		1	25	22.15	22.21	22.14	
		1	49	22.02	22.02	22.03	
		25	0	21.03	21.10	20.92	20.5±1.0
		25	13	21.04	21.09	20.91	
		25	25	21.09	21.11	21.04	
		50	0	21.01	21.06	20.87	20.5±1.0



8. LTE Band 26 Conducted Power Test Verdict:

LTE FDD Band 26(Part 22) ANT 3				Conducted Power(dBm)			Tune up
Bandwidth	Modulation	RB size	RB offset	Channel/Frequency			
				26797/824.7	26915/836.5	27033/848.3	
1.4MHz	QPSK	1	0	23.47	23.35	23.23	23.0±1.0
		1	3	23.63	23.53	23.36	
		1	5	23.44	23.34	23.23	
		3	0	22.51	22.40	22.31	22.0±1.0
		3	2	22.53	22.34	22.30	
		3	3	22.48	22.38	22.29	
	16QAM	6	0	22.52	22.29	22.28	22.0±1.0
		1	0	22.55	22.42	22.21	22.0±1.0
		1	3	22.75	22.63	22.38	
		1	5	22.59	22.42	22.22	
		3	0	21.44	21.31	21.41	21.0±1.0
		3	2	21.54	21.44	21.34	
3	3	21.45	21.34	21.42			
		6	0	21.50	21.32	21.25	21.0±1.0
Bandwidth	Modulation	RB size	RB offset	Channel/Frequency			Tune up
				26805/825.5	26915/836.5	27025/847.5	
3MHz	QPSK	1	0	23.44	23.37	23.33	23.0±1.0
		1	7	23.45	23.36	23.37	
		1	14	23.43	23.32	23.24	
		8	0	22.45	22.36	22.57	22.0±1.0
		8	4	22.46	22.43	22.44	
		8	7	22.44	22.31	22.31	
	16QAM	15	0	22.40	22.35	22.24	22.0±1.0
		1	0	22.48	22.57	22.25	22.0±1.0
		1	7	22.44	22.61	22.45	
		1	14	22.42	22.44	22.20	
		8	0	21.50	21.48	21.33	21.0±1.0
		8	4	21.49	21.51	21.39	
8	7	21.47	21.49	21.57			
		15	0	21.45	21.40	21.22	21.0±1.0



LTE FDD Band 26(Part 22) ANT 3				Conducted Power(dBm)			
Bandwidth	Modulation	RB size	RB offset	Channel/Frequency			Tune up
				26815/826.5	26915/836.5	27015/846.5	
5MHz	QPSK	1	0	23.39	23.37	23.47	23.0±1.0
		1	13	23.45	23.38	23.30	
		1	24	23.38	23.26	23.20	
		12	0	22.41	22.36	22.32	22.0±1.0
		12	6	22.40	22.37	22.32	
		12	13	22.40	22.38	22.24	
		25	0	22.40	22.41	22.27	22.0±1.0
	16QAM	1	0	22.43	22.35	22.45	22.0±1.0
		1	13	22.51	22.45	22.52	
		1	24	22.41	22.33	22.42	
		12	0	21.32	21.28	21.27	21.0±1.0
		12	6	21.32	21.31	21.30	
		12	13	21.32	21.32	21.24	
		25	0	21.40	21.37	21.25	21.0±1.0
Bandwidth	Modulation	RB size	RB offset	Channel/Frequency			Tune up
10MHz	QPSK	1	0	23.47	23.41	23.33	23.0±1.0
		1	25	23.57	23.50	23.54	
		1	49	23.55	23.29	23.26	
		25	0	22.40	22.40	22.39	22.0±1.0
		25	13	22.43	22.43	22.39	
		25	25	22.37	22.43	22.27	
		50	0	22.41	22.37	22.25	22.0±1.0
	16QAM	1	0	22.46	22.58	22.57	22.0±1.0
		1	25	22.55	22.69	22.65	
		1	49	23.38	22.51	22.44	
		25	0	21.49	21.45	21.41	21.0±1.0
		25	13	21.50	21.44	21.47	
		25	25	21.44	21.47	21.35	
		50	0	21.46	21.41	21.27	21.0±1.0



LTE FDD Band 26(Part 22) ANT 3				Conducted Power(dBm)			
Bandwidth	Modulation	RB size	RB offset	Channel/Frequency			Tune up
				26865/831.5	26915/836.5	26965/841.5	
15MHz	QPSK	1	0	23.32	23.30	23.32	23.0±1.0
		1	38	23.45	23.40	23.30	
		1	74	23.31	23.27	23.24	
		36	0	22.19	22.43	22.39	22.0±1.0
		36	18	22.26	22.53	22.41	
		36	39	22.15	22.44	22.24	
	75	0	22.17	22.43	22.36	22.0±1.0	
	16QAM	1	0	22.28	22.47	22.38	22.0±1.0
		1	38	22.39	22.53	22.43	
		1	74	22.18	22.43	22.25	
		36	0	21.19	21.44	21.40	21.0±1.0
		36	18	21.24	21.52	21.39	
		36	39	21.17	21.42	21.24	
		75	0	21.16	21.38	21.31	21.0±1.0



LTE FDD Band 26(Part 90) ANT 3				Conducted Power(dBm)			
Bandwidth	Modulation	RB size	RB offset	Channel/Frequency			Tune up
				26697/814.7	26740/819.0	26783/823.3	
1.4MHz	QPSK	1	0	23.40	23.36	23.40	23.0±1.0
		1	3	23.60	23.50	23.54	
		1	5	23.43	23.42	23.41	
		3	0	22.54	22.34	22.40	22.0±1.0
		3	2	22.55	22.31	22.39	
		3	3	22.49	22.36	22.37	
	6	0	22.47	23.29	22.31	22.0±1.0	
	16QAM	1	0	22.46	22.38	22.34	22.0±1.0
		1	3	22.61	22.52	22.39	
		1	5	22.48	22.46	22.26	
		3	0	21.47	21.40	21.28	21.0±1.0
		3	2	21.37	21.38	21.36	
		3	3	21.41	21.47	21.38	
	6	0	21.32	21.26	21.34	21.0±1.0	
Bandwidth	Modulation	RB size	RB offset	Channel/Frequency			Tune up
				26705/815.5	26740/819.0	26775/822.5	
3MHz	QPSK	1	0	23.47	23.50	23.53	23.0±1.0
		1	7	23.48	22.46	23.49	
		1	14	23.50	23.47	23.44	
		8	0	22.47	22.49	22.49	22.0±1.0
		8	4	22.46	22.65	22.48	
		8	7	22.52	22.46	22.50	
	15	0	22.49	22.41	22.47	22.0±1.0	
	16QAM	1	0	22.73	22.47	22.51	22.0±1.0
		1	7	22.65	22.52	22.46	
		1	14	22.60	22.48	22.45	
		8	0	21.46	21.73	21.53	21.0±1.0
		8	4	21.48	21.60	21.53	
		8	7	21.45	21.48	21.48	
	15	0	21.42	21.45	21.41	21.0±1.0	



LTE FDD Band 26(Part 90) ANT 3				Conducted Power(dBm)			
Bandwidth	Modulation	RB size	RB offset	Channel/Frequency			Tune up
				26715/816.5	26740/819.0	26765/821.5	
5MHz	QPSK	1	0	23.41	23.38	23.46	23.0±1.0
		1	13	23.52	23.51	23.58	
		1	24	23.44	23.39	23.45	
		12	0	22.36	22.47	22.48	22.0±1.0
		12	6	22.43	22.46	22.46	
		12	13	22.40	22.47	22.45	
		25	0	22.34	22.42	22.41	22.0±1.0
	16QAM	1	0	22.58	22.42	22.41	22.0±1.0
		1	13	22.56	22.56	22.57	
		1	24	22.45	22.47	22.46	
		12	0	21.38	21.37	21.45	21.0±1.0
		12	6	21.39	21.46	21.45	
		12	13	21.38	21.35	21.48	
		25	0	21.32	21.44	21.39	21.0±1.0
Bandwidth	Modulation	RB size	RB offset	Channel/Frequency			Tune up
10MHz	QPSK	1	0	/	23.46	/	23.0±1.0
		1	25	/	23.61	/	
		1	49	/	23.45	/	
		25	0	/	22.43	/	22.0±1.0
		25	13	/	22.51	/	
		25	25	/	22.45	/	
		50	0	/	22.44	/	22.0±1.0
	16QAM	1	0	/	22.62	/	22.0±1.0
		1	25	/	22.77	/	
		1	49	/	22.58	/	
		25	0	/	21.42	/	21.0±1.0
		25	13	/	21.40	/	
		25	25	/	21.46	/	
		50	0	/	21.37	/	21.0±1.0



9. LTE Band 41 Conducted Power Test Verdict:

LTE FDD Band 41 ANT 3				Conducted Power(dBm)			Tune up
Bandwidth	Modulation	RB size	RB offset	Channel/Frequency			
				40265/2557.5	40740/2605.0	41215/2652.5	
5MHz	QPSK	1	0	22.94	22.82	23.05	22.5±1.0
		1	13	22.76	22.87	22.89	
		1	24	22.70	22.75	22.75	
		12	0	21.64	21.80	21.62	21.5±1.0
		12	6	21.54	21.83	21.59	
		12	13	21.56	21.76	21.61	
	16QAM	25	0	21.48	21.80	21.52	21.5±1.0
		1	0	21.83	22.01	21.69	21.5±1.0
		1	13	21.75	22.02	21.68	
		1	24	21.97	21.92	21.59	
		12	0	20.72	20.82	20.93	20.5±1.0
		12	6	20.57	20.82	20.88	
12	13	20.65	20.75	20.75	20.5±1.0		
25	0	20.61	20.78	20.67			

Bandwidth	Modulation	RB size	RB offset	Channel/Frequency			Tune up
				40290/2560.0	40740/2605.0	41190/2650.0	
10MHz	QPSK	1	0	23.17	22.98	23.08	22.5±1.0
		1	25	23.09	23.14	23.16	
		1	49	22.93	23.07	22.95	
		25	0	22.03	21.90	21.79	21.5±1.0
		25	13	21.86	21.88	21.86	
		25	25	21.91	21.81	21.71	
	16QAM	50	0	21.82	21.81	21.72	21.5±1.0
		1	0	21.92	21.82	21.79	21.5±1.0
		1	25	21.74	21.94	21.81	
		1	49	21.82	21.83	21.91	
		25	0	20.75	20.72	20.73	20.5±1.0
		25	13	20.69	20.93	20.83	
25	25	20.70	20.82	20.72			
50	0	20.64	20.89	20.76	20.5±1.0		



LTE FDD Band 41 ANT 3				Conducted Power(dBm)			
Bandwidth	Modulation	RB size	RB offset	Channel/Frequency			Tune up
				40315/2562.5	40740/2605.0	41165/2647.5	
15MHz	QPSK	1	0	22.92	23.07	22.91	22.5±1.0
		1	38	23.10	22.92	23.04	
		1	74	23.06	22.84	22.89	
		36	0	21.78	21.78	21.75	21.5±1.0
		36	18	21.58	21.77	21.77	
		36	39	21.65	21.66	21.80	
		75	0	21.56	21.64	21.69	21.5±1.0
	16QAM	1	0	22.09	21.87	21.76	21.5±1.0
		1	38	22.17	21.88	21.93	
		1	74	21.95	21.79	21.86	
		36	0	20.83	20.77	20.75	20.5±1.0
		36	18	20.79	20.75	20.71	
		36	39	20.58	20.69	20.65	
		75	0	20.79	20.67	20.68	20.5±1.0
Bandwidth	Modulation	RB size	RB offset	Channel/Frequency			Tune up
				40340/2565.0	40740/2605.0	41140/2645.0	
20MHz	QPSK	1	0	22.95	22.98	23.03	22.5±1.0
		1	50	23.17	23.09	22.93	
		1	99	22.83	22.94	23.07	
		50	0	21.75	21.89	21.66	21.5±1.0
		50	25	21.78	21.87	21.64	
		50	50	21.56	21.70	21.72	
		100	0	21.46	21.79	21.55	21.5±1.0
	16QAM	1	0	21.77	21.84	21.43	21.5±1.0
		1	50	21.96	21.88	21.76	
		1	99	21.82	21.47	21.46	
		50	0	20.78	20.88	20.74	20.5±1.0
		50	25	20.64	20.90	20.52	
		50	50	20.73	20.70	20.66	
		100	0	20.61	20.79	20.53	20.5±1.0



10. LTE Band 66 Conducted Power Test Verdict:

LTE FDD Band 66 ANT 3				Conducted Power(dBm)			
Bandwidth	Modulation	RB size	RB offset	Channel/Frequency			Tune up
				131979/1710.7	132322/1745.0	132665/1779.3	
1.4MHz	QPSK	1	0	22.89	22.89	22.86	22.5±1.0
		1	3	22.76	22.86	22.69	
		1	5	22.85	22.93	22.71	
		3	0	21.73	21.86	21.72	21.5±1.0
		3	2	21.80	21.61	21.75	
		3	3	21.71	21.71	21.64	
		6	0	21.65	21.76	21.68	21.5±1.0
	16QAM	1	0	21.65	21.66	21.77	21.5±1.0
		1	3	21.76	21.81	21.65	
		1	5	21.74	21.71	21.62	
		3	0	20.69	20.61	20.69	20.0±1.0
		3	2	20.68	20.73	20.73	
		3	3	20.72	20.68	20.61	
		6	0	20.64	20.51	20.58	20.0±1.0
Bandwidth	Modulation	RB size	RB offset	Channel/Frequency			Tune up
				131987/1711.5	12322/1745.0	132657/1778.5	
3MHz	QPSK	1	0	22.84	22.98	22.87	22.5±1.0
		1	7	22.64	23.04	22.85	
		1	14	22.68	22.77	22.67	
		8	0	21.71	21.65	21.68	21.5±1.0
		8	4	21.75	21.73	21.65	
		8	7	21.69	21.61	21.71	
		15	0	21.67	21.59	21.60	21.0±1.0
	16QAM	1	0	21.68	21.70	21.75	21.5±1.0
		1	7	21.79	21.82	21.66	
		1	14	21.76	21.75	21.72	
		8	0	20.69	20.69	20.68	20.5±1.0
		8	4	20.73	20.70	20.62	
		8	7	20.66	20.68	20.75	
		15	0	20.61	20.56	20.69	20.0±1.0



LTE FDD Band 66 ANT 3				Conducted Power(dBm)			
Bandwidth	Modulation	RB size	RB offset	Channel/Frequency			Tune up
				131997/1712.5	132322/1745.0	132647/1777.5	
5MHz	QPSK	1	0	23.04	22.83	22.98	22.5±1.0
		1	13	22.94	22.96	22.80	
		1	24	22.78	22.79	22.67	
		12	0	21.81	21.72	21.76	21.5±1.0
		12	6	21.69	21.80	21.64	
		12	13	21.78	21.63	21.70	
		25	0	21.32	21.60	21.69	21.0±1.0
	16QAM	1	0	21.68	21.72	21.60	21.5±1.0
		1	13	21.74	21.84	21.71	
		1	24	21.77	21.75	21.63	
		12	0	20.63	20.72	20.65	20.0±1.0
		12	6	20.70	20.61	20.54	
		12	13	20.59	20.65	20.67	
		25	0	20.62	20.66	20.58	20.0±1.0
Bandwidth	Modulation	RB size	RB offset	Channel/Frequency			Tune up
				132022/1715.0	132322/1745.0	132622/1775.0	
10MHz	QPSK	1	0	22.93	23.07	22.87	22.5±1.0
		1	25	22.90	22.89	22.73	
		1	49	22.86	22.64	22.78	
		25	0	21.74	21.79	21.69	21.5±1.0
		25	13	21.83	21.66	21.64	
		25	25	21.69	21.75	21.72	
		50	0	21.62	21.62	21.65	21.0±1.0
	16QAM	1	0	21.81	21.73	21.72	21.5±1.0
		1	25	21.72	21.86	21.74	
		1	49	21.77	21.64	21.65	
		25	0	20.71	20.66	20.65	20.0±1.0
		25	13	20.69	20.70	20.62	
		25	25	20.74	20.61	20.57	
		50	0	20.64	20.56	20.59	20.0±1.0



LTE FDD Band 66 ANT 3				Conducted Power(dBm)			
Bandwidth	Modulation	RB size	RB offset	Channel/Frequency			Tune up
				132047/1717.5	132322/1745.0	132597/1772.5	
15MHz	QPSK	1	0	23.00	22.85	22.93	22.5±1.0
		1	38	23.05	22.91	22.87	
		1	74	22.86	22.76	22.84	
		36	0	22.83	21.81	21.80	21.5±1.0
		36	18	22.77	21.65	21.67	
		36	39	22.75	21.74	21.74	
		75	0	21.65	21.69	21.64	21.0±1.0
	16QAM	1	0	21.69	21.68	21.67	21.5±1.0
		1	38	21.70	21.62	21.58	
		1	74	21.34	21.72	21.76	
		36	0	20.73	20.63	20.69	20.0±1.0
		36	18	20.72	20.66	20.58	
		36	39	20.61	20.54	20.63	
		75	0	20.62	20.56	20.43	20.0±1.0
Bandwidth	Modulation	RB size	RB offset	Channel/Frequency			Tune up
				132072/1720.0	132322/1745.0	132572/1770.0	
20MHz	QPSK	1	0	22.93	22.91	22.85	22.5±1.0
		1	50	22.84	22.87	23.08	
		1	99	22.69	22.72	22.74	
		50	0	21.80	21.66	21.67	21.5±1.0
		50	25	21.69	21.75	21.75	
		50	50	21.76	21.67	21.58	
		100	0	21.66	21.62	21.62	21.0±1.0
	16QAM	1	0	21.71	21.72	21.69	21.5±1.0
		1	50	21.82	21.80	21.75	
		1	99	21.65	21.64	21.64	
		50	0	20.65	20.60	20.59	20.0±1.0
		50	25	20.67	20.63	20.65	
		50	50	20.55	20.55	20.44	
		100	0	20.65	20.52	20.48	20.0±1.0



7.4 WIFI Conducted Power

Wi-Fi 2.4G Output power ANT 2

2.4G WI-FI Channel/Freq.(MHz)	Output Power (dBm)		
	802.11b	802.11g	802.11n(HT20)
1/2412.0	15.88	14.73	14.63
6/2437.0	17.16	15.72	15.63
11/2462.0	15.55	14.36	14.38

2.4G WI-FI Channel/Freq.(MHz)	Output Power (dBm)
	802.11n(HT40)
3/2422.0	14.30
6/2437.0	14.44
9/2452.0	14.47

Wi-Fi U-NII-1 Output power ANT 2

Channel/Freq.(MHz)	Output Power (dBm)		
	802.11 a	802.11 n20	802.11 ac20
36/5180.0	9.92	9.58	9.86
44/5220.0	10.45	9.64	9.68
48/5240.0	10.62	9.63	9.64

Channel/Freq.(MHz)	Output Power (dBm)	
	802.11 n40	802.11 ac40
38/5190.0	8.26	8.74
46/5230.0	8.92	8.67

Channel/Freq.(MHz)	Output Power (dBm)
	802.11 ac80
42/5210.0	8.24



Wi-Fi U-NII-3 Output power ANT 2

Channel/Freq.(MHz)	Output Power (dBm)		
	802.11 a	802.11 n20	802.11 ac20
149/5745.0	10.47	9.48	9.28
157/5785.0	10.37	9.66	9.51
165/5825.0	10.19	9.57	9.62
Channel/Freq.(MHz)	Output Power (dBm)		
	802.11 n40	802.11 ac40	
151/5755.0	9.41	9.48	
159/5795.0	9.58	9.42	

Channel/Freq.(MHz)	Output Power (dBm)
	802.11 ac80
155/5775.0	9.51

7.5 Bluetooth Output Power

Channel	Frequency (MHz)	BT Output Power(dBm)		
		GFSK	$\pi/4$ -DQPSK	8-DPSK
CH 0	2402	6.47	5.94	5.93
CH 39	2441	5.80	5.00	4.99
CH 78	2480	7.08	6.46	6.46
Channel	Frequency (MHz)	BLE Output Power(dBm)		
		1M(GFSK)	2M(GFSK)	
CH 0	2402	-6.00	-6.23	
CH 19	2440	-4.95	-5.01	
CH 39	2480	-6.32	-6.33	

7.5 NFC Output Power

13.56MHz NFC	-9.78dBu/m <1mW	exclusion
--------------	-----------------	-----------

Note:

3. Per KDB248227 D01 v02r02, choose the highest output power channel to test SAR and determine further SAR exclusion
4. For each frequency band, testing at higher data rates and higher order modulations is not required when the maximum average output power for each of these configurations is less than 1/4dB higher than those measured at lowest data rate
5. Per KDB248227 D01 v02r02, 802.11g /11n-HT20/11n-HT40 is not required. . When the highest reported SAR for DSSS is adjusted by the ratio of OFDM to DSSS specified maximum output power and the adjusted SAR is $\leq 1.2W/Kg$. Thus the SAR can be excluded.

8. Antenna Location:



Antenna	Test Band
ANT 2	2.4GWIFI,5GWIFI,BT
ANT 3	GSM850 / 1900,WCDMA Band 2 / 4 / 5, LTE Band 2 / 4 / 5 / 7 / 12 / 13 / 17 / 26 / 41 / 66,



Antenna-to-User (Edge Side) distance (mm):

Antenna	Front	Back	Left	Right	Top	Bottom
ANT 2	<25	<25	<25	>25	<25	>25
ANT 3	<25	<25	<25	<25	>25	<25

The Body SAR measurement positions of each band are as below:

Antenna	Front	Back	Left	Right	Top	Bottom
ANT 2 Body	Yes	Yes	Yes	No	Yes	No
ANT 3 Body	Yes	Yes	Yes	Yes	No	Yes

Note:

1. According to KDB 941225 D06 v02r01, when antenna-to-edge>2.5cm, SAR is not required..
2. The other Frequencies were measured at the worst position



9. Scaling Factor calculation

Operation Mode	Channel /Frequency	Output Power(dBm)	Tune up Power in tolerance (dBm)	Max. Tune up(dBm)	Scaling Factor
GSM850 ANT 3	128/824.2	31.75	31.5 ± 1.0	32.50	1.189
	190/836.6	31.80	31.5 ± 1.0	32.50	1.175
	251/848.8	31.81	31.5 ± 1.0	32.50	1.172
GPRS850 (GPRS 4Tx) ANT 3	128/824.2	28.26	28.0 ± 1.0	29.00	1.186
	190/836.6	28.25	28.0 ± 1.0	29.00	1.189
	251/848.8	28.22	27.5 ± 1.0	28.50	1.067
GSM1900 ANT 3	512/1850.2	29.04	28.5 ± 1.0	29.50	1.112
	661/1880.0	28.97	28.5 ± 1.0	29.50	1.130
	810/1909.8	28.69	28.0 ± 1.0	29.00	1.074
GPRS1900 (GPRS 4Tx) ANT 3	512/1850.2	25.71	25.0 ± 1.0	26.00	1.069
	661/1880.0	25.53	25.0 ± 1.0	26.00	1.114
	810/1909.8	25.16	24.5 ± 1.0	25.50	1.081
WCDMA850 ANT 3	4132/826.4	22.00	21.5 ± 1.0	22.50	1.122
	4183/836.6	21.85	21.5 ± 1.0	22.50	1.161
	4233/846.6	21.74	21.0 ± 1.0	22.00	1.062
WCDMA1700 ANT 3	1312/1712.4	21.25	21.0 ± 1.0	22.00	1.189
	1413/1732.6	21.20	20.5 ± 1.0	21.50	1.072
	1513/1752.6	21.11	20.5 ± 1.0	21.50	1.094
WCDMA1900 ANT 3	9262/1852.4	20.74	20.0± 1.0	21.00	1.062
	9400/1880.0	20.52	20.0± 1.0	21.00	1.117
	9538/1907.6	20.61	20.0± 1.0	21.00	1.094
LTE B2 20MHz 1RB#0 ANT 3	18700/1860.0	22.43	22.0± 1.0	23.00	1.140
	18900/1880.0	22.33	22.0± 1.0	23.00	1.167
	19100/1900.0	22.39	22.0± 1.0	23.00	1.151
LTE B2 20MHz 50RB#0 ANT 3	18700/1860.0	21.34	21.0 ± 1.0	22.00	1.164
	18900/1880.0	21.12	20.5 ± 1.0	21.50	1.091
	19100/1900.0	21.23	20.5 ± 1.0	21.50	1.064
LTE B4 20MHz 1RB#0 ANT 3	20050/1720.0	22.86	22.5± 1.0	23.50	1.159
	20175/1732.5	22.91	22.5± 1.0	23.50	1.146
	20300/1745.0	22.80	22.5± 1.0	23.50	1.175
LTE B4 20MHz 50RB#0 ANT 3	20050/1720.0	21.81	21.5 ± 1.0	22.50	1.172
	20175/1732.5	21.74	21.0 ± 1.0	22.00	1.062
	20300/1745.0	21.75	21.5 ± 1.0	22.50	1.189



LTE B5 10MHz 1RB#0 ANT 3	20450/829.0	23.64	23.0 ± 1.0	24.00	1.086
	20525/836.5	23.53	23.0 ± 1.0	24.00	1.114
	20600/844.0	23.51	23.0 ± 1.0	24.00	1.119
LTE B5 10MHz 25RB#0 ANT 3	20450/829.0	22.50	22.0 ± 1.0	23.00	1.122
	20525/836.5	22.53	22.0 ± 1.0	23.00	1.114
	20600/844.0	22.42	22.0 ± 1.0	23.00	1.143
LTE B7 20MHz 1RB#0 ANT 3	20850/2510.0	17.38	17.0± 1.0	18.00	1.153
	21100/2535.0	17.34	17.0± 1.0	18.00	1.164
	21350/2560.0	17.41	17.0± 1.0	18.00	1.146
LTE B7 20MHz 50RB#0 ANT 3	20850/2510.0	16.10	15.5 ± 1.0	16.50	1.096
	21100/2535.0	16.19	15.5 ± 1.0	16.50	1.074
	21350/2560.0	16.12	15.5 ± 1.0	16.50	1.091
LTE B7 20MHz 100RB#0 ANT 3	20850/2510.0	15.94	15.5 ± 1.0	16.50	1.138
	21100/2535.0	16.11	15.5 ± 1.0	16.50	1.094
	21350/2560.0	16.08	15.5 ± 1.0	16.50	1.102
LTE B12 10MHz 1RB#0 ANT 3	23060/704.0	22.83	22.5± 1.0	23.50	1.167
	23095/707.5	22.88	22.5± 1.0	23.50	1.153
	23130/711.0	22.85	22.5± 1.0	23.50	1.161
LTE B12 10MHz 25RB#0 ANT 3	23060/704.0	22.03	21.5 ± 1.0	22.50	1.114
	23095/707.5	22.08	21.5 ± 1.0	22.50	1.102
	23130/711.0	21.88	21.5 ± 1.0	22.50	1.153
LTE B13 10MHz 1RB#0 ANT 3	23230/782.0	23.33	23.0± 1.0	24.00	1.167
LTE B13 10MHz 1RB#0 ANT 3	23230/782.0	22.33	22.0± 1.0	23.00	1.167
LTE B17 10MHz 1RB#0 ANT 3	23780/709.0	22.88	22.5± 1.0	23.50	1.153
	23790/710.0	22.99	22.5± 1.0	23.50	1.125
	23800/711.0	23.06	22.5± 1.0	23.50	1.107
LTE B17 10MHz 25RB#0 ANT 3	23780/709.0	22.01	21.5 ± 1.0	22.50	1.119
	23790/710.0	22.00	21.5 ± 1.0	22.50	1.122
	23800/711.0	21.87	21.5 ± 1.0	22.50	1.156
LTE B26(Part 22) 15MHz 1RB#0 ANT 3	26865/831.5	23.32	23.0 ± 1.0	24.00	1.169
	26915/836.5	23.30	23.0 ± 1.0	24.00	1.175
	26965/841.5	23.32	23.0 ± 1.0	24.00	1.169
LTE B26(Part 22) 15MHz 50%RB#0 ANT 3	26865/831.5	22.19	21.5 ± 1.0	22.50	1.074
	26915/836.5	22.43	22.0 ± 1.0	23.00	1.140
	26965/841.5	22.39	22.0 ± 1.0	23.00	1.151



LTE B26(Part 90) 10MHz 1RB#0 ANT 3	26740/819.0	23.46	23.0 ± 1.0	24.00	1.132
LTE B26(Part 90) 10MHz 50%RB#0 ANT 3	26740/819.0	22.43	22.0 ± 1.0	23.00	1.140
LTE B41 20MHz 1RB#0 ANT 3	40340/2565.0	22.95	22.5 ± 1.0	23.50	1.135
	40740/2605.0	22.98	22.5 ± 1.0	23.50	1.127
	41140/2645.0	23.03	22.5 ± 1.0	23.50	1.114
LTE B41 20MHz 50RB#0 ANT 3	40340/2565.0	21.75	21.0 ± 1.0	22.00	1.059
	40740/2605.0	21.89	21.5 ± 1.0	22.50	1.151
	41140/2645.0	21.66	21.0 ± 1.0	22.00	1.081
LTE B41 20MHz 100RB#0 ANT 3	40340/2565.0	21.46	21.0 ± 1.0	22.00	1.132
	40740/2605.0	21.79	21.5 ± 1.0	22.50	1.178
	41140/2645.0	21.55	21.0 ± 1.0	22.00	1.109
LTE B66 20MHz 1RB#0 ANT 3	132072/1720.0	22.93	22.5 ± 1.0	23.50	1.140
	132322/1745.0	22.91	22.5 ± 1.0	23.50	1.146
	132572/1770.0	22.85	22.5 ± 1.0	23.50	1.161
LTE B66 20MHz 50RB#0 ANT 3	132072/1720.0	21.80	21.5 ± 1.0	22.50	1.175
	132322/1745.0	21.66	21.0 ± 1.0	22.00	1.081
	132572/1770.0	21.67	21.0 ± 1.0	22.00	1.079
WIFI 2.4G 802.11b ANT 2	1/2412.0	15.88	15.5 ± 1.0	16.50	1.153
	6/2437.0	17.16	16.5 ± 1.0	17.50	1.081
	11/2462.0	15.55	15.0 ± 1.0	16.00	1.109
WIFI U-NII 1 802.11a ANT 2	36/5180.0	9.92	9.5 ± 1.0	10.50	1.143
	44/5220.0	10.45	10.0 ± 1.0	11.00	1.135
	48/5240.0	10.62	10.0 ± 1.0	11.00	1.091
WIFI U-NII 3 802.11a ANT 2	149/5745.0	10.47	10.0 ± 1.0	11.00	1.130
	157/5785.0	10.37	10.0 ± 1.0	11.00	1.156
	165/5825.0	10.19	9.5 ± 1.0	10.50	1.074
BT ANT 2	0/2402.0	6.47	6.0 ± 1.0	7.00	1.130
	39/2441.0	5.80	5.5 ± 1.0	6.50	1.175
	78/2480.0	7.08	6.5 ± 1.0	7.50	1.102

Note: for LTE power tolerance, only QPSK modulation mode was provide here.



10. Test Results

Results overview of GSM850

ANT 3

Head	Channel /Frequency	Mode	SAR Value (W/kg)1-g	Power drift(%)	Scaled Factor	Scaled SAR (W/Kg)1-g	Limit (W/kg)	SAR Plot.
Right Cheek	190/836.6	Voice	0.239	0.78	1.175	0.281	1.6	/
Right Tilted	190/836.6	Voice	0.102	-0.17	1.175	0.120	1.6	/
Left Cheek	190/836.6	Voice	0.257	-1.34	1.175	0.302	1.6	1
Left Tilted	190/836.6	Voice	0.113	-0.49	1.175	0.133	1.6	/
Body-worn(10mm)	Channel /Frequency	Mode	SAR Value (W/kg)1-g	Power drift(%)	Scaled Factor	Scaled SAR (W/Kg)1-g	Limit (W/kg)	SAR Plot.
Front Upward	190/836.6	GPRS 4Tx	0.322	-0.67	1.189	0.383	1.6	/
Back Upward	190/836.6	GPRS 4Tx	0.421	2.18	1.189	0.501	1.6	2
Hotspot(10mm)	Channel /Frequency	Mode	SAR Value (W/kg)1-g	Power drift(%)	Scaled Factor	Scaled SAR (W/Kg)1-g	Limit (W/kg)	SAR Plot.
Front Upward	190/836.6	GPRS 4Tx	0.322	-0.67	1.189	0.383	1.6	/
Back Upward	190/836.6	GPRS 4Tx	0.421	2.18	1.189	0.501	1.6	2
Left	190/836.6	GPRS 4Tx	0.095	-0.83	1.189	0.113	1.6	/
Right	190/836.6	GPRS 4Tx	0.112	-2.39	1.189	0.133	1.6	/
Bottom	190/836.6	GPRS 4Tx	0.142	-1.55	1.189	0.169	1.6	/

**Results overview of GSM1900**

ANT 3

Head	Channel /Frequency	Mode	SAR Value (W/kg)1-g	Power drift(%)	Scaled Factor	Scaled SAR (W/Kg)1-g	Limit (W/kg)	SAR Plot.
Right Cheek	661/1880.0	Voice	0.341	1.01	1.130	0.385	1.6	3
Right Tilted	661/1880.0	Voice	0.158	-0.53	1.130	0.179	1.6	/
Left Cheek	661/1880.0	Voice	0.259	-2.77	1.130	0.293	1.6	/
Left Tilted	661/1880.0	Voice	0.118	-1.28	1.130	0.133	1.6	/
Body-worn(10mm)	Channel /Frequency	Mode	SAR Value (W/kg)1-g	Power drift(%)	Scaled Factor	Scaled SAR (W/Kg)1-g	Limit (W/kg)	SAR Plot.
Front Upward	661/1880.0	GPRS 4Tx	0.386	-0.63	1.114	0.430	1.6	4
Back Upward	661/1880.0	GPRS 4Tx	0.366	0.22	1.114	0.408	1.6	/
Hotspot(10mm)	Channel /Frequency	Mode	SAR Value (W/kg)1-g	Power drift(%)	Scaled Factor	Scaled SAR (W/Kg)1-g	Limit (W/kg)	SAR Plot.
Front Upward	661/1880.0	GPRS 4Tx	0.386	-0.63	1.114	0.430	1.6	/
Back Upward	661/1880.0	GPRS 4Tx	0.366	0.22	1.114	0.408	1.6	/
Left	661/1880.0	GPRS 4Tx	0.156	-0.52	1.114	0.174	1.6	/
Right	661/1880.0	GPRS 4Tx	0.179	-2.77	1.114	0.199	1.6	/
Bottom	661/1880.0	GPRS 4Tx	0.516	-1.24	1.114	0.575	1.6	5

**Results overview of WCDMA850**

ANT 3

Head	Channel /Frequency	Mode	SAR Value (W/kg)1-g	Power drift(%)	Scaled Factor	Scaled SAR (W/Kg)1-g	Limit (W/kg)	SAR Plot.
Right Cheek	4183/836.6	RMC	0.373	-0.80	1.161	0.433	1.6	6
Right Tilted	4183/836.6	RMC	0.122	-0.59	1.161	0.142	1.6	/
Left Cheek	4183/836.6	RMC	0.358	1.35	1.161	0.416	1.6	/
Left Tilted	4183/836.6	RMC	0.114	-2.69	1.161	0.132	1.6	/
Body-worn(10mm)	Channel /Frequency	Mode	SAR Value (W/kg)1-g	Power drift(%)	Scaled Factor	Scaled SAR (W/Kg)1-g	Limit (W/kg)	SAR Plot.
Front Upward	4183/836.6	RMC	0.252	0.70	1.161	0.293	1.6	/
Back Upward	4183/836.6	RMC	0.361	-1.15	1.161	0.419	1.6	7
Hotspot(10mm)	Channel /Frequency	Mode	SAR Value (W/kg)1-g	Power drift(%)	Scaled Factor	Scaled SAR (W/Kg)1-g	Limit (W/kg)	SAR Plot.
Front Upward	4183/836.6	RMC	0.252	0.70	1.161	0.293	1.6	/
Back Upward	4183/836.6	RMC	0.361	-1.15	1.161	0.419	1.6	7
Left	4183/836.6	RMC	0.085	-0.78	1.161	0.099	1.6	/
Right	4183/836.6	RMC	0.098	-2.41	1.161	0.114	1.6	/
Bottom	4183/836.6	RMC	0.119	-0.96	1.161	0.138	1.6	/

**Results overview of WCDMA1700**

ANT 3

Head	Channel /Frequency	Mode	SAR Value (W/kg)1-g	Power drift(%)	Scaled Factor	Scaled SAR (W/Kg)1-g	Limit (W/kg)	SAR Plot.
Right Cheek	1413/1732.6	RMC	0.333	-0.30	1.072	0.357	1.6	/
Right Tilted	1413/1732.6	RMC	0.114	-2.01	1.072	0.122	1.6	/
Left Cheek	1413/1732.6	RMC	0.385	0.91	1.072	0.413	1.6	8
Left Tilted	1413/1732.6	RMC	0.162	-1.13	1.072	0.174	1.6	/
Body-worn(10mm)	Channel /Frequency	Mode	SAR Value (W/kg)1-g	Power drift(%)	Scaled Factor	Scaled SAR (W/Kg)1-g	Limit (W/kg)	SAR Plot.
Front Upward	1413/1732.6	RMC	0.420	-0.29	1.072	0.450	1.6	9
Back Upward	1413/1732.6	RMC	0.364	-2.51	1.072	0.390	1.6	/
Hotspot(10mm)	Channel /Frequency	Mode	SAR Value (W/kg)1-g	Power drift(%)	Scaled Factor	Scaled SAR (W/Kg)1-g	Limit (W/kg)	SAR Plot.
Front Upward	1413/1732.6	RMC	0.420	-0.29	1.072	0.450	1.6	/
Back Upward	1413/1732.6	RMC	0.364	-2.51	1.072	0.390	1.6	/
Left	1413/1732.6	RMC	0.168	-1.41	1.072	0.180	1.6	/
Right	1413/1732.6	RMC	0.126	-0.74	1.072	0.135	1.6	/
Bottom	1413/1732.6	RMC	0.478	0.15	1.072	0.512	1.6	10

**Results overview of WCDMA1900**

ANT 3

Head	Channel /Frequency	Mode	SAR Value (W/kg)1-g	Power drift(%)	Scaled Factor	Scaled SAR (W/Kg)1-g	Limit (W/kg)	SAR Plot.
Right Cheek	9400/1880.0	RMC	0.268	-1.44	1.117	0.299	1.6	/
Right Tilted	9400/1880.0	RMC	0.118	-0.52	1.117	0.132	1.6	/
Left Cheek	9400/1880.0	RMC	0.299	-0.47	1.117	0.334	1.6	11
Left Tilted	9400/1880.0	RMC	0.137	-0.62	1.117	0.153	1.6	/
Body-worn(10mm)	Channel /Frequency	Mode	SAR Value (W/kg)1-g	Power drift(%)	Scaled Factor	Scaled SAR (W/Kg)1-g	Limit (W/kg)	SAR Plot.
Front Upward	9400/1880.0	RMC	0.489	0.11	1.117	0.546	1.6	12
Back Upward	9400/1880.0	RMC	0.312	-2.33	1.117	0.349	1.6	/
Hotspot(10mm)	Channel /Frequency	Mode	SAR Value (W/kg)1-g	Power drift(%)	Scaled Factor	Scaled SAR (W/Kg)1-g	Limit (W/kg)	SAR Plot.
Front Upward	9400/1880.0	RMC	0.489	0.11	1.117	0.546	1.6	12
Back Upward	9400/1880.0	RMC	0.312	-2.33	1.117	0.349	1.6	/
Left	9400/1880.0	RMC	0.192	0.24	1.117	0.214	1.6	/
Right	9400/1880.0	RMC	0.157	-53	1.117	0.175	1.6	/
Bottom	9400/1880.0	RMC	0.425	-2.78	1.117	0.475	1.6	/



Results overview of FDD LTE Band 2, QPSK, 20MHz Bandwidth

ANT 3

Head	Channel /Frequency	Mode	SAR Value (W/kg)1-g	Power drift(%)	Scaled Factor	Scaled SAR (W/Kg)1-g	Limit (W/kg)	SAR Plot.
1RB#0								
Right Cheek	18900/1880.0	QPSK	0.376	-3.46	1.167	0.439	1.6	/
Right Tilted	18900/1880.0	QPSK	0.161	-0.26	1.167	0.188	1.6	/
Left Cheek	18900/1880.0	QPSK	0.387	-1.17	1.167	0.452	1.6	13
Left Tilted	18900/1880.0	QPSK	0.166	-0.14	1.167	0.194	1.6	/
50%RB#0								
Right Cheek	18900/1880.0	QPSK	0.258	0.27	1.091	0.281	1.6	/
Right Tilted	18900/1880.0	QPSK	0.118	-0.12	1.091	0.129	1.6	/
Left Cheek	18900/1880.0	QPSK	0.269	-3.28	1.091	0.293	1.6	/
Left Tilted	18900/1880.0	QPSK	0.125	-0.21	1.091	0.136	1.6	/
Body-worn(10mm)	Channel /Frequency	Mode	SAR Value (W/kg)1-g	Power drift(%)	Scaled Factor	Scaled SAR (W/Kg)1-g	Limit (W/kg)	SAR Plot.
1RB#0								
Front Upward	18900/1880.0	QPSK	0.536	1.33	1.167	0.626	1.6	14
Back Upward	18900/1880.0	QPSK	0.395	-0.21	1.167	0.461	1.6	/
50%RB#0								
Front Upward	18900/1880.0	QPSK	0.380	-1.02	1.091	0.415	1.6	/
Back Upward	18900/1880.0	QPSK	0.259	3.54	1.091	0.283	1.6	/
Hotspot(10mm)	Channel /Frequency	Mode	SAR Value (W/kg)1-g	Power drift(%)	Scaled Factor	Scaled SAR (W/Kg)1-g	Limit (W/kg)	SAR Plot.
1RB#0								
Front Upward	18900/1880.0	QPSK	0.536	1.33	1.167	0.626	1.6	/
Back Upward	18900/1880.0	QPSK	0.395	-0.21	1.167	0.461	1.6	/
Left	18900/1880.0	QPSK	0.151	-0.29	1.167	0.176	1.6	/
Right	18900/1880.0	QPSK	0.132	-2.63	1.167	0.154	1.6	/
Bottom	18900/1880.0	QPSK	0.588	-3.31	1.167	0.686	1.6	15
50%RB#0								
Front Upward	18900/1880.0	QPSK	0.380	-1.02	1.091	0.415	1.6	/
Back Upward	18900/1880.0	QPSK	0.259	3.54	1.091	0.283	1.6	/
Left	18900/1880.0	QPSK	0.102	-1.85	1.091	0.111	1.6	/
Right	18900/1880.0	QPSK	0.089	1.16	1.091	0.097	1.6	/
Bottom	18900/1880.0	QPSK	0.442	-1.85	1.091	0.482	1.6	/



Results overview of FDD LTE Band 4, QPSK, 20MHz Bandwidth

ANT 3

Head	Channel /Frequency	Mode	SAR Value (W/kg)1-g	Power drift(%)	Scaled Factor	Scaled SAR (W/Kg)1-g	Limit (W/kg)	SAR Plot.
1RB#0								
Right Cheek	20175/1732.5	QPSK	0.388	-0.18	1.146	0.445	1.6	16
Right Tilted	20175/1732.5	QPSK	0.169	-0.40	1.146	0.194	1.6	/
Left Cheek	20175/1732.5	QPSK	0.375	2.86	1.146	0.430	1.6	/
Left Tilted	20175/1732.5	QPSK	0.160	-1.22	1.146	0.183	1.6	/
50%RB#0								
Right Cheek	20175/1732.5	QPSK	0.313	1.23	1.062	0.332	1.6	/
Right Tilted	20175/1732.5	QPSK	0.128	-0.66	1.062	0.136	1.6	/
Left Cheek	20175/1732.5	QPSK	0.301	-2.01	1.062	0.320	1.6	/
Left Tilted	20175/1732.5	QPSK	0.120	-0.84	1.062	0.127	1.6	/
Body-worn(10mm)	Channel /Frequency	Mode	SAR Value (W/kg)1-g	Power drift(%)	Scaled Factor	Scaled SAR (W/Kg)1-g	Limit (W/kg)	SAR Plot.
1RB#0								
Front Upward	20175/1732.5	QPSK	0.665	0.47	1.146	0.762	1.6	17
Back Upward	20175/1732.5	QPSK	0.428	-3.36	1.146	0.490	1.6	/
50%RB#0								
Front Upward	20175/1732.5	QPSK	0.509	-2.46	1.062	0.541	1.6	/
Back Upward	20175/1732.5	QPSK	0.311	-0.17	1.062	0.330	1.6	/
Hotspot(10mm)	Channel /Frequency	Mode	SAR Value (W/kg)1-g	Power drift(%)	Scaled Factor	Scaled SAR (W/Kg)1-g	Limit (W/kg)	SAR Plot.
1RB#0								
Front Upward	20175/1732.5	QPSK	0.665	0.47	1.146	0.762	1.6	17
Back Upward	20175/1732.5	QPSK	0.428	-3.36	1.146	0.490	1.6	/
Left	20175/1732.5	QPSK	0.203	0.35	1.146	0.233	1.6	/
Right	20175/1732.5	QPSK	0.237	1.34	1.146	0.272	1.6	/
Bottom	20175/1732.5	QPSK	0.523	-0.37	1.146	0.599	1.6	/
50%RB#0								
Front Upward	20175/1732.5	QPSK	0.509	-2.46	1.062	0.541	1.6	/
Back Upward	20175/1732.5	QPSK	0.311	-0.17	1.062	0.330	1.6	/
Left	20175/1732.5	QPSK	0.122	-2.26	1.062	0.130	1.6	/
Right	20175/1732.5	QPSK	0.139	0.81	1.062	0.148	1.6	/
Bottom	20175/1732.5	QPSK	0.454	-1.21	1.062	0.482	1.6	/



Results overview of FDD LTE Band 5, QPSK, 10MHz Bandwidth

ANT 3

Head	Channel /Frequency	Mode	SAR Value (W/kg)1-g	Power drift(%)	Scaled Factor	Scaled SAR (W/Kg)1-g	Limit (W/kg)	SAR Plot.
1RB#0								
Right Cheek	20525/836.5	QPSK	0.470	1.55	1.114	0.524	1.6	18
Right Tilted	20525/836.5	QPSK	0.218	0.79	1.114	0.243	1.6	/
Left Cheek	20525/836.5	QPSK	0.396	-1.44	1.114	0.441	1.6	/
Left Tilted	20525/836.5	QPSK	0.176	-2.35	1.114	0.196	1.6	/
50%RB#0								
Right Cheek	20525/836.5	QPSK	0.378	-2.00	1.114	0.421	1.6	/
Right Tilted	20525/836.5	QPSK	0.185	-0.76	1.114	0.206	1.6	/
Left Cheek	20525/836.5	QPSK	0.331	-0.90	1.114	0.369	1.6	/
Left Tilted	20525/836.5	QPSK	0.142	0.18	1.114	0.158	1.6	/
Body-worn(10mm)	Channel /Frequency	Mode	SAR Value (W/kg)1-g	Power drift(%)	Scaled Factor	Scaled SAR (W/Kg)1-g	Limit (W/kg)	SAR Plot.
1RB#0								
Front Upward	20525/836.5	QPSK	0.346	-3.81	1.114	0.385	1.6	/
Back Upward	20525/836.5	QPSK	0.414	1.12	1.114	0.461	1.6	19
50%RB#0								
Front Upward	20525/836.5	QPSK	0.258	-2.06	1.114	0.287	1.6	/
Back Upward	20525/836.5	QPSK	0.329	-1.68	1.114	0.367	1.6	/
Hotspot(10mm)	Channel /Frequency	Mode	SAR Value (W/kg)1-g	Power drift(%)	Scaled Factor	Scaled SAR (W/Kg)1-g	Limit (W/kg)	SAR Plot.
1RB#0								
Front Upward	20525/836.5	QPSK	0.346	-3.81	1.114	0.385	1.6	/
Back Upward	20525/836.5	QPSK	0.414	1.12	1.114	0.461	1.6	19
Left	20525/836.5	QPSK	0.123	-0.18	1.114	0.137	1.6	/
Right	20525/836.5	QPSK	0.105	-1.20	1.114	0.117	1.6	/
Bottom	20525/836.5	QPSK	0.178	-0.38	1.114	0.198	1.6	/
50%RB#0								
Front Upward	20525/836.5	QPSK	0.258	-2.06	1.114	0.287	1.6	/
Back Upward	20525/836.5	QPSK	0.329	-1.68	1.114	0.367	1.6	/
Left	20525/836.5	QPSK	0.093	2.45	1.114	0.104	1.6	/
Right	20525/836.5	QPSK	0.080	-0.24	1.114	0.089	1.6	/
Bottom	20525/836.5	QPSK	0.131	0.92	1.114	0.146	1.6	/



Results overview of FDD LTE Band 7, QPSK, 20MHz Bandwidth

ANT 3

Head	Channel /Frequency	Mode	SAR Value (W/kg)1-g	Power drift(%)	Scaled Factor	Scaled SAR (W/Kg)1-g	Limit (W/kg)	SAR Plot.
1RB#0								
Right Cheek	21100/2535.0	QPSK	0.241	-2.04	1.164	0.281	1.6	20
Right Tilted	21100/2535.0	QPSK	0.102	0.14	1.164	0.119	1.6	/
Left Cheek	21100/2535.0	QPSK	0.185	-0.51	1.164	0.215	1.6	/
Left Tilted	21100/2535.0	QPSK	0.086	-0.83	1.164	0.100	1.6	/
50%RB#0								
Right Cheek	21100/2535.0	QPSK	0.151	-0.81	1.074	0.162	1.6	/
Right Tilted	21100/2535.0	QPSK	0.082	-1.07	1.074	0.088	1.6	/
Left Cheek	21100/2535.0	QPSK	0.119	2.58	1.074	0.128	1.6	/
Left Tilted	21100/2535.0	QPSK	0.067	-1.13	1.074	0.072	1.6	/
Body-worn(10mm)	Channel /Frequency	Mode	SAR Value (W/kg)1-g	Power drift(%)	Scaled Factor	Scaled SAR (W/Kg)1-g	Limit (W/kg)	SAR Plot.
1RB#0								
Front Upward	21100/2535.0	QPSK	0.266	1.40	1.164	0.310	1.6	/
Back Upward	21100/2535.0	QPSK	0.643	-0.55	1.164	0.748	1.6	21
50%RB#0								
Front Upward	21100/2535.0	QPSK	0.208	-0.50	1.074	0.223	1.6	/
Back Upward	21100/2535.0	QPSK	0.565	-1.66	1.074	0.607	1.6	/
Hotspot(10mm)	Channel /Frequency	Mode	SAR Value (W/kg)1-g	Power drift(%)	Scaled Factor	Scaled SAR (W/Kg)1-g	Limit (W/kg)	SAR Plot.
1RB#0								
Front Upward	21100/2535.0	QPSK	0.266	1.40	1.164	0.310	1.6	/
Back Upward	21100/2535.0	QPSK	0.643	-0.55	1.164	0.748	1.6	/
Left	21100/2535.0	QPSK	0.129	2.14	1.164	0.150	1.6	/
Right	21100/2535.0	QPSK	0.185	-0.87	1.164	0.215	1.6	/
Bottom	21100/2535.0	QPSK	0.711	0.43	1.164	0.828	1.6	/
Bottom	20850/2510.0	QPSK	0.754	-0.89	1.153	0.869	1.6	22
Bottom	21350/2560.0	QPSK	0.672	-1.36	1.146	0.770	1.6	/
50%RB#0								
Front Upward	21100/2535.0	QPSK	0.208	-0.50	1.074	0.223	1.6	/
Back Upward	21100/2535.0	QPSK	0.565	-1.66	1.074	0.607	1.6	/
Left	21100/2535.0	QPSK	0.087	-0.38	1.074	0.093	1.6	/
Right	21100/2535.0	QPSK	0.112	-1.45	1.074	0.120	1.6	/
Bottom	21100/2535.0	QPSK	0.635	-0.99	1.074	0.682	1.6	/
100%RB#0								
Front Upward	21100/2535.0	QPSK	0.201	-0.11	1.094	0.220	1.6	/
Back Upward	21100/2535.0	QPSK	0.549	0.34	1.094	0.601	1.6	/
Left	21100/2535.0	QPSK	0.082	-0.59	1.094	0.090	1.6	/
Right	21100/2535.0	QPSK	0.106	-1.92	1.094	0.116	1.6	/



Bottom	21100/2535.0	QPSK	0.602	-0.32	1.094	0.659	1.6	/
--------	--------------	------	-------	-------	-------	-------	-----	---



Results overview of FDD LTE Band 12, QPSK, 10MHz Bandwidth

ANT 3

Head	Channel /Frequency	Mode	SAR Value (W/kg)1-g	Power drift(%)	Scaled Factor	Scaled SAR (W/Kg)1-g	Limit (W/kg)	SAR Plot.
1RB#0								
Right Cheek	23095/707.5	QPSK	0.192	-0.12	1.153	0.221	1.6	23
Right Tilted	23095/707.5	QPSK	0.088	2.01	1.153	0.101	1.6	/
Left Cheek	23095/707.5	QPSK	0.179	-1.67	1.153	0.206	1.6	/
Left Tilted	23095/707.5	QPSK	0.082	-0.24	1.153	0.095	1.6	/
50%RB#0								
Right Cheek	23095/707.5	QPSK	0.161	2.09	1.102	0.177	1.6	/
Right Tilted	23095/707.5	QPSK	0.073	-1.05	1.102	0.080	1.6	/
Left Cheek	23095/707.5	QPSK	0.152	-0.36	1.102	0.168	1.6	/
Left Tilted	23095/707.5	QPSK	0.068	-0.29	1.102	0.075	1.6	/
Body-worn(10mm)	Channel /Frequency	Mode	SAR Value (W/kg)1-g	Power drift(%)	Scaled Factor	Scaled SAR (W/Kg)1-g	Limit (W/kg)	SAR Plot.
1RB#0								
Front Upward	23095/707.5	QPSK	0.198	-2.12	1.153	0.228	1.6	/
Back Upward	23095/707.5	QPSK	0.244	-0.43	1.153	0.281	1.6	24
50%RB#0								
Front Upward	23095/707.5	QPSK	0.152	0.24	1.102	0.168	1.6	/
Back Upward	23095/707.5	QPSK	0.210	-0.15	1.102	0.231	1.6	/
Hotspot(10mm)	Channel /Frequency	Mode	SAR Value (W/kg)1-g	Power drift(%)	Scaled Factor	Scaled SAR (W/Kg)1-g	Limit (W/kg)	SAR Plot.
1RB#0								
Front Upward	23095/707.5	QPSK	0.198	-2.12	1.153	0.228	1.6	/
Back Upward	23095/707.5	QPSK	0.244	-0.43	1.153	0.281	1.6	24
Left	23095/707.5	QPSK	0.069	-3.18	1.153	0.080	1.6	/
Right	23095/707.5	QPSK	0.052	1.23	1.153	0.060	1.6	/
Bottom	23095/707.5	QPSK	0.073	0.12	1.153	0.084	1.6	/
50%RB#0								
Front Upward	23095/707.5	QPSK	0.152	0.24	1.102	0.168	1.6	/
Back Upward	23095/707.5	QPSK	0.210	-0.15	1.102	0.231	1.6	/
Left	23095/707.5	QPSK	0.057	-1.55	1.102	0.063	1.6	/
Right	23095/707.5	QPSK	0.040	-0.90	1.102	0.044	1.6	/
Bottom	23095/707.5	QPSK	0.061	-0.54	1.102	0.067	1.6	/



Results overview of FDD LTE Band 13, QPSK, 10MHz Bandwidth

ANT 3

Head	Channel /Frequency	Mode	SAR Value (W/kg)1-g	Power drift(%)	Scaled Factor	Scaled SAR (W/Kg)1-g	Limit (W/kg)	SAR Plot.
1RB#0								
Right Cheek	23230/782.0	QPSK	0.510	-0.47	1.167	0.595	1.6	25
Right Tilted	23230/782.0	QPSK	0.232	2.23	1.167	0.271	1.6	/
Left Cheek	23230/782.0	QPSK	0.463	-0.32	1.167	0.540	1.6	/
Left Tilted	23230/782.0	QPSK	0.204	-1.00	1.167	0.238	1.6	/
50%RB#0								
Right Cheek	23230/782.0	QPSK	0.458	1.34	1.167	0.534	1.6	/
Right Tilted	23230/782.0	QPSK	0.185	-0.70	1.167	0.216	1.6	/
Left Cheek	23230/782.0	QPSK	0.382	-0.94	1.167	0.446	1.6	/
Left Tilted	23230/782.0	QPSK	0.159	0.36	1.167	0.186	1.6	/
Body-worn(10mm)	Channel /Frequency	Mode	SAR Value (W/kg)1-g	Power drift(%)	Scaled Factor	Scaled SAR (W/Kg)1-g	Limit (W/kg)	SAR Plot.
1RB#0								
Front Upward	23230/782.0	QPSK	0.522	-2.08	1.167	0.609	1.6	26
Back Upward	23230/782.0	QPSK	0.465	0.72	1.167	0.543	1.6	/
50%RB#0								
Front Upward	23230/782.0	QPSK	0.448	-0.91	1.167	0.523	1.6	/
Back Upward	23230/782.0	QPSK	0.401	0.18	1.167	0.468	1.6	/
Hotspot(10mm)	Channel /Frequency	Mode	SAR Value (W/kg)1-g	Power drift(%)	Scaled Factor	Scaled SAR (W/Kg)1-g	Limit (W/kg)	SAR Plot.
1RB#0								
Front Upward	23230/782.0	QPSK	0.522	-2.08	1.167	0.609	1.6	26
Back Upward	23230/782.0	QPSK	0.465	0.72	1.167	0.543	1.6	/
Left	23230/782.0	QPSK	0.162	-0.38	1.167	0.189	1.6	/
Right	23230/782.0	QPSK	0.122	-2.05	1.167	0.142	1.6	/
Bottom	23230/782.0	QPSK	0.148	-0.27	1.167	0.173	1.6	/
50%RB#0								
Front Upward	23230/782.0	QPSK	0.448	-0.91	1.167	0.523	1.6	/
Back Upward	23230/782.0	QPSK	0.401	0.18	1.167	0.468	1.6	/
Left	23230/782.0	QPSK	0.117	0.89	1.167	0.137	1.6	/
Right	23230/782.0	QPSK	0.090	-0.64	1.167	0.105	1.6	/
Bottom	23230/782.0	QPSK	0.107	0.53	1.167	0.125	1.6	/



Results overview of FDD LTE Band 17, QPSK, 10MHz Bandwidth

ANT 3

Head	Channel /Frequency	Mode	SAR Value (W/kg)1-g	Power drift(%)	Scaled Factor	Scaled SAR (W/Kg)1-g	Limit (W/kg)	SAR Plot.
1RB#0								
Right Cheek	23790/710.0	QPSK	0.222	0.63	1.125	0.250	1.6	/
Right Tilted	23790/710.0	QPSK	0.101	-3.59	1.125	0.114	1.6	/
Left Cheek	23790/710.0	QPSK	0.231	-0.20	1.125	0.260	1.6	27
Left Tilted	23790/710.0	QPSK	0.108	-2.93	1.125	0.122	1.6	/
50%RB#0								
Right Cheek	23790/710.0	QPSK	0.192	1.32	1.122	0.215	1.6	/
Right Tilted	23790/710.0	QPSK	0.090	-0.50	1.122	0.101	1.6	/
Left Cheek	23790/710.0	QPSK	0.200	-1.43	1.122	0.224	1.6	/
Left Tilted	23790/710.0	QPSK	0.095	-2.02	1.122	0.107	1.6	/
Body-worn(10mm)	Channel /Frequency	Mode	SAR Value (W/kg)1-g	Power drift(%)	Scaled Factor	Scaled SAR (W/Kg)1-g	Limit (W/kg)	SAR Plot.
1RB#0								
Front Upward	23790/710.0	QPSK	0.258	-1.44	1.125	0.290	1.6	/
Back Upward	23790/710.0	QPSK	0.267	-3.37	1.125	0.300	1.6	28
50%RB#0								
Front Upward	23790/710.0	QPSK	0.185	2.05	1.122	0.208	1.6	/
Back Upward	23790/710.0	QPSK	0.209	-1.71	1.122	0.234	1.6	/
Hotspot(10mm)	Channel /Frequency	Mode	SAR Value (W/kg)1-g	Power drift(%)	Scaled Factor	Scaled SAR (W/Kg)1-g	Limit (W/kg)	SAR Plot.
1RB#0								
Front Upward	23095/707.5	QPSK	0.258	-1.44	1.125	0.290	1.6	/
Back Upward	23095/707.5	QPSK	0.267	-3.37	1.125	0.300	1.6	28
Left	23095/707.5	QPSK	0.079	0.29	1.125	0.089	1.6	/
Right	23095/707.5	QPSK	0.085	-1.52	1.125	0.096	1.6	/
Bottom	23790/710.0	QPSK	0.072	0.62	1.125	0.081	1.6	/
50%RB#0								
Front Upward	23790/710.0	QPSK	0.185	2.05	1.122	0.208	1.6	/
Back Upward	23790/710.0	QPSK	0.209	-1.71	1.122	0.234	1.6	/
Left	23790/710.0	QPSK	0.062	-0.96	1.122	0.070	1.6	/
Right	23790/710.0	QPSK	0.069	-1.35	1.122	0.077	1.6	/
Bottom	23790/710.0	QPSK	0.058	-0.52	1.122	0.065	1.6	/



Results overview of FDD LTE Band 26(Part 22), QPSK, 15MHz Bandwidth

ANT 3

Head	Channel /Frequency	Mode	SAR Value (W/kg)1-g	Power drift(%)	Scaled Factor	Scaled SAR (W/Kg)1-g	Limit (W/kg)	SAR Plot.
1RB#0								
Right Cheek	26915/836.5	QPSK	0.386	-1.47	1.175	0.454	1.6	/
Right Tilted	26915/836.5	QPSK	0.178	1.89	1.175	0.209	1.6	/
Left Cheek	26915/836.5	QPSK	0.445	-2.57	1.175	0.523	1.6	29
Left Tilted	26915/836.5	QPSK	0.210	-0.75	1.175	0.247	1.6	/
50%RB#0								
Right Cheek	26915/836.5	QPSK	0.302	-0.73	1.140	0.344	1.6	/
Right Tilted	26915/836.5	QPSK	0.112	-2.25	1.140	0.128	1.6	/
Left Cheek	26915/836.5	QPSK	0.365	-1.63	1.140	0.416	1.6	/
Left Tilted	26915/836.5	QPSK	0.159	0.81	1.140	0.181	1.6	/
Body-worn(10mm)	Channel /Frequency	Mode	SAR Value (W/kg)1-g	Power drift(%)	Scaled Factor	Scaled SAR (W/Kg)1-g	Limit (W/kg)	SAR Plot.
1RB#0								
Front Upward	26915/836.5	QPSK	0.382	0.65	1.175	0.449	1.6	/
Back Upward	26915/836.5	QPSK	0.437	-2.78	1.175	0.513	1.6	30
50%RB#0								
Front Upward	26915/836.5	QPSK	0.306	-1.50	1.140	0.349	1.6	/
Back Upward	26915/836.5	QPSK	0.359	-2.42	1.140	0.409	1.6	/
Hotspot(10mm)	Channel /Frequency	Mode	SAR Value (W/kg)1-g	Power drift(%)	Scaled Factor	Scaled SAR (W/Kg)1-g	Limit (W/kg)	SAR Plot.
1RB#0								
Front Upward	26915/836.5	QPSK	0.382	0.65	1.175	0.449	1.6	/
Back Upward	26915/836.5	QPSK	0.437	-2.78	1.175	0.513	1.6	30
Left	26915/836.5	QPSK	0.112	-2.03	1.175	0.132	1.6	/
Right	26915/836.5	QPSK	0.162	-1.89	1.175	0.190	1.6	/
Bottom	26915/836.5	QPSK	0.153	-1.23	1.175	0.180	1.6	/
50%RB#0								
Front Upward	26915/836.5	QPSK	0.306	-1.50	1.140	0.349	1.6	/
Back Upward	26915/836.5	QPSK	0.359	-2.42	1.140	0.409	1.6	/
Left	26915/836.5	QPSK	0.095	-2.46	1.140	0.108	1.6	/
Right	26915/836.5	QPSK	0.118	0.35	1.140	0.135	1.6	/
Bottom	26915/836.5	QPSK	0.110	0.40	1.140	0.125	1.6	/



Results overview of FDD LTE Band 26(Part 90), QPSK, 10MHz Bandwidth

ANT 3

Head	Channel /Frequency	Mode	SAR Value (W/kg)1-g	Power drift(%)	Scaled Factor	Scaled SAR (W/Kg)1-g	Limit (W/kg)	SAR Plot.
1RB#0								
Right Cheek	26740/819.0	QPSK	0.481	1.23	1.132	0.544	1.6	31
Right Tilted	26740/819.0	QPSK	0.217	-0.54	1.132	0.246	1.6	/
Left Cheek	26740/819.0	QPSK	0.478	-1.27	1.132	0.541	1.6	/
Left Tilted	26740/819.0	QPSK	0.211	0.14	1.132	0.239	1.6	/
50%RB#0								
Right Cheek	26740/819.0	QPSK	0.374	-2.05	1.140	0.426	1.6	/
Right Tilted	26740/819.0	QPSK	0.156	-2.76	1.140	0.178	1.6	/
Left Cheek	26740/819.0	QPSK	0.365	-1.18	1.140	0.416	1.6	/
Left Tilted	26740/819.0	QPSK	0.148	-0.26	1.140	0.169	1.6	/
Body-worn(10mm)	Channel /Frequency	Mode	SAR Value (W/kg)1-g	Power drift(%)	Scaled Factor	Scaled SAR (W/Kg)1-g	Limit (W/kg)	SAR Plot.
1RB#0								
Front Upward	26740/819.0	QPSK	0.427	-0.36	1.132	0.483	1.6	32
Back Upward	26740/819.0	QPSK	0.411	0.68	1.132	0.465	1.6	/
50%RB#0								
Front Upward	26740/819.0	QPSK	0.337	-1.54	1.140	0.384	1.6	/
Back Upward	26740/819.0	QPSK	0.318	0.23	1.140	0.363	1.6	/
Hotspot(10mm)	Channel /Frequency	Mode	SAR Value (W/kg)1-g	Power drift(%)	Scaled Factor	Scaled SAR (W/Kg)1-g	Limit (W/kg)	SAR Plot.
1RB#0								
Front Upward	26740/819.0	QPSK	0.427	-0.36	1.132	0.483	1.6	32
Back Upward	26740/819.0	QPSK	0.411	0.68	1.132	0.465	1.6	/
Left	26740/819.0	QPSK	0.096	-1.54	1.132	0.109	1.6	/
Right	26740/819.0	QPSK	0.105	-1.46	1.132	0.119	1.6	/
Bottom	26740/819.0	QPSK	0.145	-2.33	1.132	0.164	1.6	/
50%RB#0								
Front Upward	26740/819.0	QPSK	0.337	-1.54	1.140	0.384	1.6	/
Back Upward	26740/819.0	QPSK	0.318	0.23	1.140	0.363	1.6	/
Left	26740/819.0	QPSK	0.082	-3.65	1.140	0.093	1.6	/
Right	26740/819.0	QPSK	0.090	-0.29	1.140	0.103	1.6	/
Bottom	26740/819.0	QPSK	0.118	1.90	1.140	0.135	1.6	/



Results overview of FDD LTE Band 41, QPSK, 20MHz Bandwidth

ANT 3

Head	Channel /Frequency	Mode	SAR Value (W/kg)1-g	Power drift(%)	Scaled Factor	Scaled SAR (W/Kg)1-g	Limit (W/kg)	SAR Plot.
1RB#0								
Right Cheek	40740/2605.0	QPSK	0.148	-0.76	1.127	0.167	1.6	33
Right Tilted	40740/2605.0	QPSK	0.065	1.54	1.127	0.073	1.6	/
Left Cheek	40740/2605.0	QPSK	0.124	0.50	1.127	0.140	1.6	/
Left Tilted	40740/2605.0	QPSK	0.054	-0.18	1.127	0.061	1.6	/
50%RB#0								
Right Cheek	40740/2605.0	QPSK	0.118	-1.47	1.151	0.136	1.6	/
Right Tilted	40740/2605.0	QPSK	0.056	-3.91	1.151	0.064	1.6	/
Left Cheek	40740/2605.0	QPSK	0.103	-0.58	1.151	0.119	1.6	/
Left Tilted	40740/2605.0	QPSK	0.045	0.43	1.151	0.052	1.6	/
Body-worn(10mm)	Channel /Frequency	Mode	SAR Value (W/kg)1-g	Power drift(%)	Scaled Factor	Scaled SAR (W/Kg)1-g	Limit (W/kg)	SAR Plot.
1RB#0								
Front Upward	40740/2605.0	QPSK	0.802	0.62	1.127	0.904	1.6	/
Back Upward	40740/2605.0	QPSK	0.696	-0.81	1.127	0.784	1.6	/
Front Upward	40340/2565.0	QPSK	0.745	-2.20	1.135	0.846	1.6	/
Front Upward	41140/2645.0	QPSK	0.858	0.12	1.114	0.956	1.6	/
Front Upward Repeat	41140/2645.0	QPSK	0.878	1.15	1.114	0.978	1.6	34
50%RB#0								
Front Upward	40740/2605.0	QPSK	0.715	1.35	1.151	0.823	1.6	/
Back Upward	40740/2605.0	QPSK	0.575	-2.42	1.151	0.662	1.6	/
Front Upward	40340/2565.0	QPSK	0.682	-0.71	1.059	0.722	1.6	/
Front Upward	41140/2645.0	QPSK	0.640	-2.20	1.081	0.692	1.6	/
Hotspot(10mm)	Channel /Frequency	Mode	SAR Value (W/kg)1-g	Power drift(%)	Scaled Factor	Scaled SAR (W/Kg)1-g	Limit (W/kg)	SAR Plot.
1RB#0								
Front Upward	40740/2605.0	QPSK	0.802	0.62	1.127	0.904	1.6	/
Front Upward	40340/2565.0	QPSK	0.745	-2.20	1.135	0.846	1.6	/
Front Upward	41140/2645.0	QPSK	0.858	0.12	1.114	0.956	1.6	/
Front Upward Repeat	41140/2645.0	QPSK	0.878	1.15	1.114	0.978	1.6	/
Back Upward	40740/2605.0	QPSK	0.696	-0.81	1.127	0.784	1.6	/
Left	40740/2605.0	QPSK	0.279	0.73	1.127	0.314	1.6	/
Right	40740/2605.0	QPSK	0.331	-2.94	1.127	0.373	1.6	/
Bottom	40740/2605.0	QPSK	1.004	-0.91	1.127	1.132	1.6	/
Bottom	40340/2565.0	QPSK	0.918	0.57	1.135	1.042	1.6	/
Bottom	41140/2645.0	QPSK	1.055	-2.04	1.114	1.175	1.6	35
Bottom	41140/2645.0	QPSK	1.043	-0.91	1.114	1.162	1.6	/



Repeat								
50%RB#0								
Front Upward	40740/2605.0	QPSK	0.715	1.35	1.151	0.823	1.6	/
Front Upward	40340/2565.0	QPSK	0.682	-0.71	1.059	0.722	1.6	/
Front Upward	41140/2645.0	QPSK	0.640	-2.20	1.081	0.692	1.6	/
Back Upward	40740/2605.0	QPSK	0.575	-2.42	1.151	0.662	1.6	/
Left	40740/2605.0	QPSK	0.212	-0.27	1.151	0.244	1.6	/
Right	40740/2605.0	QPSK	0.269	1.43	1.151	0.310	1.6	/
Bottom	40740/2605.0	QPSK	0.885	-0.74	1.151	1.019	1.6	/
Bottom Repeat	40740/2605.0	QPSK	0.861	-1.69	1.151	0.991	1.6	/
Bottom	40340/2565.0	QPSK	0.813	0.28	1.059	0.861	1.6	/
Bottom	41140/2645.0	QPSK	0.746	-0.91	1.081	0.806	1.6	/
100%RB#0								
Front Upward	40740/2605.0	QPSK	0.662	-2.63	1.178	0.780	1.6	/
Back Upward	40740/2605.0	QPSK	0.606	0.17	1.178	0.714	1.6	/
Left	40740/2605.0	QPSK	0.169	-3.28	1.178	0.199	1.6	/
Right	40740/2605.0	QPSK	0.201	-2.10	1.178	0.237	1.6	/
Bottom	40740/2605.0	QPSK	0.756	1.38	1.178	0.891	1.6	/
Bottom	40340/2565.0	QPSK	0.695	-0.29	1.132	0.787	1.6	/
Bottom	41140/2645.0	QPSK	0.789	-2.24	1.109	0.875	1.6	/



Results overview of FDD LTE Band 66, QPSK, 20MHz Bandwidth

ANT 3

Head	Channel /Frequency	Mode	SAR Value (W/kg)1-g	Power drift(%)	Scaled Factor	Scaled SAR (W/Kg)1-g	Limit (W/kg)	SAR Plot.
1RB#0								
Right Cheek	132322/1745.0	QPSK	0.497	-1.31	1.146	0.570	1.6	36
Right Tilted	132322/1745.0	QPSK	0.221	2.39	1.146	0.253	1.6	/
Left Cheek	132322/1745.0	QPSK	0.359	-0.84	1.146	0.411	1.6	/
Left Tilted	132322/1745.0	QPSK	0.161	-0.13	1.146	0.185	1.6	/
50%RB#0								
Right Cheek	132322/1745.0	QPSK	0.368	1.38	1.081	0.398	1.6	/
Right Tilted	132322/1745.0	QPSK	0.171	-0.72	1.081	0.185	1.6	/
Left Cheek	132322/1745.0	QPSK	0.284	-0.12	1.081	0.307	1.6	/
Left Tilted	132322/1745.0	QPSK	0.119	1.35	1.081	0.129	1.6	/
Body-worn(10mm)	Channel /Frequency	Mode	SAR Value (W/kg)1-g	Power drift(%)	Scaled Factor	Scaled SAR (W/Kg)1-g	Limit (W/kg)	SAR Plot.
1RB#0								
Front Upward	132322/1745.0	QPSK	0.603	1.66	1.146	0.691	1.6	37
Back Upward	132322/1745.0	QPSK	0.409	-2.15	1.146	0.469	1.6	/
50%RB#0								
Front Upward	132322/1745.0	QPSK	0.459	-0.14	1.081	0.496	1.6	/
Back Upward	132322/1745.0	QPSK	0.314	0.57	1.081	0.339	1.6	/
Hotspot(10mm)	Channel /Frequency	Mode	SAR Value (W/kg)1-g	Power drift(%)	Scaled Factor	Scaled SAR (W/Kg)1-g	Limit (W/kg)	SAR Plot.
1RB#0								
Front Upward	132322/1745.0	QPSK	0.603	1.66	1.146	0.691	1.6	/
Back Upward	132322/1745.0	QPSK	0.409	-2.15	1.146	0.469	1.6	/
Left	132322/1745.0	QPSK	0.215	0.57	1.146	0.246	1.6	/
Right	132322/1745.0	QPSK	0.226	-1.50	1.146	0.259	1.6	/
Bottom	132322/1745.0	QPSK	0.626	-0.54	1.146	0.717	1.6	38
50%RB#0								
Front Upward	132322/1745.0	QPSK	0.459	-0.14	1.081	0.496	1.6	/
Back Upward	132322/1745.0	QPSK	0.314	0.57	1.081	0.339	1.6	/
Left	132322/1745.0	QPSK	0.144	0.49	1.081	0.156	1.6	/
Right	132322/1745.0	QPSK	0.156	-0.33	1.081	0.169	1.6	/
Bottom	132322/1745.0	QPSK	0.481	-0.40	1.081	0.520	1.6	/

**Results overview of WIFI2.4G 802.11b**

ANT 2

Head	Channel /Frequency	Mode	SAR Value (W/kg)1-g	Power drift(%)	Scaled Factor	Scaled SAR (W/Kg)1-g	Limit (W/kg)	SAR Plot.
Right Cheek	6/2437.0	802.11b	0.332	-0.17	1.081	0.359	1.6	/
Right Tilted	6/2437.0	802.11b	0.189	-2.31	1.081	0.204	1.6	/
Left Cheek	6/2437.0	802.11b	0.410	0.29	1.081	0.443	1.6	39
Left Tilted	6/2437.0	802.11b	0.234	-0.65	1.081	0.253	1.6	/
Body-worn(10mm)	Channel /Frequency	Mode	SAR Value (W/kg)1-g	Power drift(%)	Scaled Factor	Scaled SAR (W/Kg)1-g	Limit (W/kg)	SAR Plot.
Front Upward	6/2437.0	802.11b	0.101	1.55	1.081	0.109	1.6	/
Back Upward	6/2437.0	802.11b	0.152	-0.35	1.081	0.164	1.6	40
Hotspot(10mm)	Channel /Frequency	Mode	SAR Value (W/kg)1-g	Power drift(%)	Scaled Factor	Scaled SAR (W/Kg)1-g	Limit (W/kg)	SAR Plot.
Front Upward	6/2437.0	802.11b	0.101	1.55	1.081	0.109	1.6	/
Back Upward	6/2437.0	802.11b	0.152	-0.35	1.081	0.164	1.6	40
Left	6/2437.0	802.11b	0.126	-0.36	1.081	0.136	1.6	/
Top	6/2437.0	802.11b	0.069	2.26	1.081	0.075	1.6	/

Results overview of WIFI U-NII 1 802.11a

ANT 2

Head	Channel /Frequency	Mode	SAR Value (W/kg)1-g	Power drift(%)	Scaled Factor	Scaled SAR (W/Kg)1-g	Limit (W/kg)	SAR Plot.
Right Cheek	44/5220.0	802.11a	0.231	-0.98	1.135	0.231	1.6	/
Right Tilted	44/5220.0	802.11a	0.163	0.55	1.135	0.163	1.6	/
Left Cheek	44/5220.0	802.11a	0.296	1.64	1.135	0.296	1.6	41
Left Tilted	44/5220.0	802.11a	0.189	0.24	1.135	0.189	1.6	/
Body-worn(10mm)	Channel /Frequency	Mode	SAR Value (W/kg)1-g	Power drift(%)	Scaled Factor	Scaled SAR (W/Kg)1-g	Limit (W/kg)	SAR Plot.
Front Upward	44/5220.0	802.11a	0.312	2.65	1.135	0.354	1.6	/
Back Upward	44/5220.0	802.11a	0.459	-0.93	1.135	0.521	1.6	42

**Results overview of WIFI U-NII 3 802.11a**

ANT 3

Head	Channel /Frequency	Mode	SAR Value (W/kg)1-g	Power drift(%)	Scaled Factor	Scaled SAR (W/Kg)1-g	Limit (W/kg)	SAR Plot.
Right Cheek	157/5785.0	802.11a	0.315	1.05	1.156	0.364	1.6	/
Right Tilted	157/5785.0	802.11a	0.173	-2.72	1.156	0.200	1.6	/
Left Cheek	157/5785.0	802.11a	0.386	-2.97	1.156	0.446	1.6	43
Left Tilted	157/5785.0	802.11a	0.221	0.71	1.156	0.255	1.6	/
Body-worn(10mm)	Channel /Frequency	Mode	SAR Value (W/kg)1-g	Power drift(%)	Scaled Factor	Scaled SAR (W/Kg)1-g	Limit (W/kg)	SAR Plot.
Front Upward	157/5785.0	802.11a	0.225	-0.55	1.156	0.260	1.6	/
Back Upward	157/5785.0	802.11a	0.311	-1.60	1.156	0.360	1.6	44

Results overview of BT

ANT 3

Head	Channel /Frequency	Mode	SAR Value (W/kg)1-g	Power drift(%)	Scaled Factor	Scaled SAR (W/Kg)1-g	Limit (W/kg)	SAR Plot.
Right Cheek	39/2441.0	DH5	0.049	-2.84	1.175	0.058	1.6	/
Right Tilted	39/2441.0	DH5	0.028	0.28	1.175	0.033	1.6	/
Left Cheek	39/2441.0	DH5	0.056	-1.36	1.175	0.066	1.6	45
Left Tilted	39/2441.0	DH5	0.033	-2.40	1.175	0.039	1.6	/
Body-worn(10mm)	Channel /Frequency	Mode	SAR Value (W/kg)1-g	Power drift(%)	Scaled Factor	Scaled SAR (W/Kg)1-g	Limit (W/kg)	SAR Plot.
Front Upward	39/2441.0	DH5	0.040	-1.63	1.175	0.047	1.6	/
Back Upward	39/2441.0	DH5	0.070	-0.19	1.175	0.082	1.6	46

Note:

Per KDB941225 D06 v02r01, When the antenna-to-edge distance is greater than 2.5cm, such position does not need to be tested. As the manufacture requirement the separation distance use 5mm for Hotspot mode.

Per KDB Publication 941225 D01v03r01. RMC 12.2kbps was as primary mode SAR, when the primary mode SAR less than 1.2W/kg, secondary SAR (HSPA) was not requires.

When the 1-g SAR for the mid-band channel or the channel with the highest output power satisfy the following conditions, testing of the other channels in the band is not required. (Per KDB 447498 D01 General RF Exposure Guidance v06)

- ≤ 0.8 W/kg, when the transmission band is ≤ 100 MHz
- ≤ 0.6 W/kg, when the transmission band is between 100 MHz and 200 MHz
- ≤ 0.4 W/kg, when the transmission band is ≥ 200 MHz



11. Simultaneous Transmissions Analysis

Localized Specific Absorption Rate (SAR) of this portable wireless device has been measured in all cases requested by the relevant standards cited in Clause 6 of this report. Maximum localized SAR is **below** exposure limits specified in the relevant standards.

Simultaneous SAR

No.	Transmitter Combinations	Head	Body	Hotspot
1	WWAN + WLAN 2.4GHz	Support	Support	Support
2	WWAN + WLAN 5GHz	Support	Support	No
3	WWAN+ Bluetooth	Support	Support	No

Note:

1. EUT will choose each GSM, WCDMA, LTE according to the network signal condition; therefore, they will not operate simultaneously at any moment.
2. The reported SAR summation is calculated based on the same configuration and test position.



Simultaneous Tx Combination of GSM/WCDMA/LTE and BT/WIFI (Head)

Test Position/Freq.	Right Cheek	Right Tilted	Left Cheek	Left Tilted	
Head MAX 1-g SAR(W/Kg)	GSM 850 ANT 3	0.281	0.120	0.302	0.133
	GSM 1900 ANT 3	0.385	0.179	0.293	0.133
	WCDMA 850 ANT 3	0.433	0.142	0.416	0.132
	WCDMA 1700 ANT 3	0.357	0.122	0.413	0.174
	WCDMA 1900 ANT 3	0.299	0.132	0.334	0.153
	LTE Band 2 ANT 3	0.439	0.188	0.452	0.194
	LTE Band 4 ANT 3	0.445	0.194	0.430	0.183
	LTE Band 5 ANT 3	0.524	0.243	0.441	0.196
	LTE Band 7 ANT 3	0.281	0.119	0.215	0.100
	LTE Band 12 ANT 3	0.221	0.101	0.206	0.095
	LTE Band 13 ANT 3	0.595	0.271	0.540	0.238
	LTE Band 17 ANT 3	0.250	0.114	0.260	0.122
	LTE Band 26 (Part 22)ANT 3	0.454	0.209	0.523	0.247
	LTE Band 26 (Part 90)ANT 3	0.544	0.246	0.541	0.239
	LTE Band 41 ANT 3	0.167	0.073	0.140	0.061
	LTE Band 66 ANT 3	0.570	0.253	0.411	0.185
	WIFI 2.4G ANT 2	0.359	0.204	0.443	0.253
	WIFI 5G U-NII 1 ANT 2	0.231	0.163	0.296	0.189
	WIFI 5G U-NII 3 ANT 2	0.364	0.200	0.446	0.255
BT ANT 2	0.058	0.033	0.066	0.039	
WWAN MAX SAR	0.595	0.271	0.541	0.247	
WIFI/BT MAX SAR	0.364	0.204	0.446	0.255	
Max Simultaneous \sum 1-g SAR(W/Kg) (WIFI/BT MAX SAR +WWAN ANT MAX SAR)	0.959	0.475	0.987	0.502	



Simultaneous Tx Combination of GSM/WCDMA/LTE and BT/WIFI (Body).

Test Position		Front	Back	Left	Right	Top	Bottom
Body MAX 1-g SAR(W/Kg) 10mm distance	GSM 850 ANT 3	0.383	0.501	/	/	/	/
	GSM 1900 ANT 3	0.430	0.408	/	/	/	/
	WCDMA 850 ANT 3	0.293	0.419	/	/	/	/
	WCDMA 1700 ANT 3	0.450	0.390	/	/	/	/
	WCDMA 1900 ANT 3	0.546	0.349	/	/	/	/
	LTE Band 2 ANT 3	0.626	0.461	/	/	/	/
	LTE Band 4 ANT 3	0.762	0.490	/	/	/	/
	LTE Band 5 ANT 3	0.385	0.461	/	/	/	/
	LTE Band 7 ANT 3	0.310	0.748	/	/	/	/
	LTE Band 12 ANT 3	0.228	0.281	/	/	/	/
	LTE Band 13 ANT 3	0.609	0.543	/	/	/	/
	LTE Band 17 ANT 3	0.290	0.300	/	/	/	/
	LTE Band 26 (Part 22)ANT 3	0.449	0.513	/	/	/	/
	LTE Band 26 (Part 90)ANT 3	0.483	0.465	/	/	/	/
	LTE Band 41 ANT 3	0.978	0.784	/	/	/	/
	LTE Band 66 ANT 3	0.691	0.469	/	/	/	/
	WIFI 2.4G ANT 2	0.109	0.164	/	/	/	/
	WIFI 5G U-NII 1 ANT 2	0.354	0.521	/	/	/	/
WIFI 5G U-NII 3 ANT 2	0.260	0.360	/	/	/	/	
BT ANT 2	0.047	0.082	/	/	/	/	
WWAN MAX SAR	0.978	0.784	/	/	/	/	
WIFI/BT MAX SAR	0.354	0.521	/	/	/	/	
Max Simultaneous \sum 10-g SAR(W/Kg) (WIFI/BT MAX SAR +WWAN ANT MAX SAR)	1.332	1.305	/	/	/	/	



Simultaneous Tx Combination of GSM/WCDMA/LTE and WIFI (Hotspot).

Test Position		Front	Back	Left	Right	Top	Bottom
Hotspot MAX 1-g SAR(W/Kg) 10mm distance	GSM 850 ANT 3	0.383	0.501	0.113	0.133	/	0.169
	GSM 1900 ANT 3	0.430	0.408	0.174	0.199	/	0.575
	WCDMA 850 ANT 3	0.293	0.419	0.099	0.114	/	0.138
	WCDMA 1700 ANT 3	0.450	0.390	0.180	0.135	/	0.512
	WCDMA 1900 ANT 3	0.546	0.349	0.214	0.175	/	0.475
	LTE Band 2 ANT 3	0.686	0.461	0.176	0.154	/	0.686
	LTE Band 4 ANT 3	0.762	0.490	0.233	0.272	/	0.599
	LTE Band 5 ANT 3	0.385	0.461	0.137	0.117	/	0.198
	LTE Band 7 ANT 3	0.310	0.748	0.150	0.215	/	0.869
	LTE Band 12 ANT 3	0.228	0.281	0.080	0.060	/	0.084
	LTE Band 13 ANT 3	0.609	0.543	0.189	0.142	/	0.173
	LTE Band 17 ANT 3	0.290	0.300	0.089	0.096	/	0.081
	LTE Band 26 (Part 22)ANT 3	0.449	0.513	0.132	0.190	/	0.180
	LTE Band 26 (Part 90)ANT 3	0.483	0.465	0.109	0.119	/	0.164
	LTE Band 41 ANT 3	0.978	0.784	0.314	0.373	/	1.175
	LTE Band 66 ANT 3	0.691	0.469	0.246	0.259	/	0.717
WIFI 2.4G ANT 2	0.109	0.164	0.136	/	0.075	/	
WWAN MAX SAR		0.978	0.784	0.314	0.373	/	1.175
WIFI/BT MAX SAR		0.109	0.164	0.136	/	0.075	/
Max Simultaneous \sum 10-g SAR(W/Kg) (WIFI/BT MAX SAR +WWAN ANT MAX SAR)		1.087	0.948	0.450	0.373	0.075	1.175

SAR to Peak Location Separation Ratio (SPLSR)

As the Sum of the SAR is not greater than 1.6 W/kg SPLSR assessment is not required

12. Measurement Uncertainty

No.	Uncertainty Component	Type	Uncertainty Value (%)	Probability Distribution	k	ci	Standard Uncertainty (%) $u_i(\%)$	Degree of freedom ν_{eff} or ν_i
Measurement System								
1	– Probe Calibration	B	5.8	N	1	1	5.8	∞
2	– Axial isotropy	B	3.5	R	$\sqrt{3}$	0.5	1.43	∞
3	– Hemispherical Isotropy	B	5.9	R	$\sqrt{3}$	0.5	2.41	∞
4	– Boundary Effect	B	1	R	$\sqrt{3}$	1	0.58	∞
5	– Linearity	B	4.7	R	$\sqrt{3}$	1	2.71	∞
6	– System Detection Limits	B	1.0	R	$\sqrt{3}$	1	0.58	∞
7	Modulation response	B	3	N	1	1	3.00	
8	– Readout Electronics	B	0.5	N	1	1	0.50	∞
9	– Response Time	B	1.4	R	$\sqrt{3}$	1	0.81	∞
10	– Integration Time	B	3.0	R	$\sqrt{3}$	1	1.73	∞
11	– RF Ambient Conditions	B	3.0	R	$\sqrt{3}$	1	1.73	∞
12	– Probe Position Mechanical tolerance	B	1.4	R	$\sqrt{3}$	1	0.81	∞
13	– Probe Position with respect to Phantom Shell	B	1.4	R	$\sqrt{3}$	1	0.81	∞
14	– Extrapolation, Interpolation and Integration Algorithms for Max. SAR evaluation	B	2.3	R	$\sqrt{3}$	1	1.33	∞
Uncertainties of the DUT								



15	- Position of the DUT	A	2.6	N	$\sqrt{3}$	1	2.6	5
16	- Holder of the DUT	A	3	N	$\sqrt{3}$	1	3.0	5
17	- Output Power Variation – SAR drift measurement	B	5.0	R	$\sqrt{3}$	1	2.89	∞
Phantom and Tissue Parameters								
18	- Phantom Uncertainty(shape and thickness tolerances)	B	4	R	$\sqrt{3}$	1	2.31	∞
19	Uncertainty in SAR correction for deviation(in permittivity and conductivity)	B	2	N	1	1	2.00	
20	- Liquid Conductivity Target – tolerance	B	2.5	R	$\sqrt{3}$	0.6	1.95	∞
21	- Liquid Conductivity – measurement Uncertainty)	B	4	N	$\sqrt{3}$	1	0.92	9
22	- Liquid Permittivity Target tolerance	B	2.5	R	$\sqrt{3}$	0.6	1.95	∞
23	- Liquid Permittivity – measurement uncertainty	B	5	N	$\sqrt{3}$	1	1.15	∞
Combined Standard Uncertainty				RSS			10.63	
Expanded uncertainty (Confidence interval of 95 %)				K=2			21.26	

System Check Uncertainty

No.	Uncertainty Component	Type	Uncertainty Value (%)	Probability Distribution	k	ci	Standard Uncertainty (%) ui(%)	Degree of freedom Veff or vi
Measurement System								
1	- Probe Calibration	B	5.8	N	1	1	5.8	∞
2	- Axial isotropy	B	3.5	R	$\sqrt{3}$	0.5	1.43	∞



3	– Hemispherical Isotropy	B	5.9	R	$\sqrt{3}$	0.5	2.41	∞
4	– Boundary Effect	B	1	R	$\sqrt{3}$	1	0.58	∞
5	– Linearity	B	4.7	R	$\sqrt{3}$	1	2.71	∞
6	– System Detection Limits	B	1	R	$\sqrt{3}$	1	0.58	∞
7	Modulation response	B	0	N	1	1	0.00	
8	– Readout Electronics	B	0.5	N	1	1	0.50	∞
9	– Response Time	B	0.00	R	$\sqrt{3}$	1	0.00	∞
10	– Integration Time	B	1.4	R	$\sqrt{3}$	1	0.81	∞
11	– RF Ambient Conditions	B	3.0	R	$\sqrt{3}$	1	1.73	∞
12	– Probe Position Mechanical tolerance	B	1.4	R	$\sqrt{3}$	1	0.81	∞
13	– Probe Position with respect to Phantom Shell	B	1.4	R	$\sqrt{3}$	1	0.81	∞
14	– Extrapolation, Interpolation and Integration Algorithms for Max. SAR evaluation	B	2.3	R	$\sqrt{3}$	1	1.33	∞
Uncertainties of the DUT								
15	Deviation of experimental source from numerical source	A	4	N	1	1	4.00	5
16	Input Power and SAR drift measurement	A	5	R	$\sqrt{3}$	1	2.89	5
17	Dipole Axis to Liquid Distance	B	2	R	$\sqrt{3}$	1	1.2	∞
Phantom and Tissue Parameters								
18	– Phantom Uncertainty(shape	B	4	R	$\sqrt{3}$	1	2.31	∞



	and thickness tolerances)							
19	Uncertainty in SAR correction for deviation(in permittivity and conductivity)	B	2	N	1	1	2.00	
20	– Liquid Conductivity Target – tolerance	B	2.5	R	$\sqrt{3}$	0.6	1.95	∞
21	– Liquid Conductivity – measurement Uncertainty)	B	4	N	$\sqrt{3}$	1	0.92	9
22	– Liquid Permittivity Target tolerance	B	2.5	R	$\sqrt{3}$	0.6	1.95	∞
23	– Liquid Permittivity – measurement uncertainty	B	5	N	$\sqrt{3}$	1	1.15	∞
Combined Standard Uncertainty				RSS			10.15	
Expanded uncertainty (Confidence interval of 95 %)				K=2			20.29	



13. Equipment List

This table is a complete overview of the SAR measurement equipment. Devices used during the test described are marked .

	EQUIPMENT	Model	Serial number	Calibration Date	Due Date
<input checked="" type="checkbox"/>	SAR Probe	SSE2	0523-EPGO-403	2023/02/14	2024/02/13
<input checked="" type="checkbox"/>	Dipole	SID750	SN 23/15 DIP0G750-378	2023/05/24	2026/05/23
<input checked="" type="checkbox"/>	Dipole	SID835	SN 09/13 DIP0G835-217	2023/05/24	2026/05/23
<input checked="" type="checkbox"/>	Dipole	SID1800	SN 09/13 DIP1G800-216	2023/05/24	2026/05/23
<input checked="" type="checkbox"/>	Dipole	SID1900	SN 09/13 DIP1G900-218	2023/05/24	2026/05/23
<input checked="" type="checkbox"/>	Dipole	SID2300	SN 20/20 DIP2G300-525	2023/05/24	2026/05/23
<input checked="" type="checkbox"/>	Dipole	SID2450	SN 09/13 DIP2G450-220	2023/05/24	2026/05/23
<input checked="" type="checkbox"/>	Dipole	SID2600	SN 32/14 DIP2G600-338	2023/05/24	2026/05/23
<input checked="" type="checkbox"/>	Dipole	SWG5500	SN15/15 WGA39	2023/05/25	2026/05/24
<input checked="" type="checkbox"/>	Multimeter	Keithley-2000	4014020	2023/02/20	2024/02/19
<input checked="" type="checkbox"/>	System Simulator(R&S)	CMW500	149332	2022/12/13	2023/12/12
<input checked="" type="checkbox"/>	KEYSIGHT	E7515A	MY56040357	2023/02/20	2024/02/19
<input checked="" type="checkbox"/>	Vector Network Analyzer(R&S)	ZVB8	100343	2023/02/20	2024/02/19
<input checked="" type="checkbox"/>	PC 3.5 Fixed Match Calibration Kit	ZV-Z32	100571	2023/02/20	2024/02/19
<input checked="" type="checkbox"/>	Dielectric Probe Kit	SCLMP	SN 09/13 OCPG51	2023/02/20	2024/02/19
<input checked="" type="checkbox"/>	Signal Generator	SMU100A	177649	2023/02/20	2024/02/19
<input checked="" type="checkbox"/>	Amplifier	Nucletudes	143060	2023/02/20	2024/02/19
<input checked="" type="checkbox"/>	Directional Coupler	DC6180A	305827	2023/06/15	2024/06/14
<input checked="" type="checkbox"/>	Power Meter	NRP2	103434	2023/02/20	2024/02/19



ANNEX A: Appendix A: SAR System performance Check Plots

(Please See Appendix A)

ANNEX B: Appendix B: SAR Measurement results Plots

(Please See Appendix B)

ANNEX C: Appendix C: Calibration reports

(Please See Appendix C)

ANNEX D: Appendix D: SAR Test Setup

(Please See Appendix D)

—End of the Report—