



TEST REPORT

Report No. : **CHEW21100005** Report Verification: 
 Project No..... : **SHT2107003404EW**
 FCC ID..... : **2AYEZ-TE620**
 Applicant's name..... : **Telo Communication (Shenzhen) Co., Ltd**
 Address..... : **6/F, No.42 Liuxian 1st Road, Bao'an District, Shenzhen, China**
 Test item description : **TE620**
 Trade Mark : **TELOX, Telo Systems**
 Model/Type reference..... : **TE620**
 Listed Model(s) : **TELOX-TE620, Telo-TE620, TE620A, TE620B, TE620C, TE620D, TE620E, TE620F, TE620G, TE620H, TE620J, TE620K, TE620L, TE620M, TE620Q, TE620R, TE620S, TE620T, TE620U, TE620V, TE620X, TE620Y**
 Standard : **FCC CFR Title 47 Part 15 Subpart C Section 15.247**
 Date of receipt of test sample..... : **Sep. 10, 2021**
 Date of testing..... : **Sep. 11, 2021- Oct. 08, 2021**
 Date of issue..... : **Oct. 09, 2021**
 Result..... : **PASS**

Compiled by (Position+Printed name+Signature):	File administrator Silvia Li	
Supervised by (Position+Printed name+Signature):	Project Engineer Aaron Fang	
Approved by (Position+Printed name+Signature):	RF Manager Hans Hu	

Testing Laboratory Name : **Shenzhen Huatongwei International Inspection Co., Ltd.**
 Address..... : **1/F, Bldg 3, Hongfa Hi-tech Industrial Park, Genyu Road, Tianliao, Gongming, Shenzhen, China**

Shenzhen Huatongwei International Inspection Co., Ltd. All rights reserved.

This publication may be reproduced in whole or in part for non-commercial purposes as long as the Shenzhen Huatongwei International Inspection Co., Ltd. is acknowledged as copyright owner and source of the material. Shenzhen Huatongwei International Inspection Co., Ltd. takes no responsibility for and will not assume liability for damages resulting from the reader's interpretation of the reproduced material due to its placement and context.

The test report merely correspond to the test sample.

Contents

1.	TEST STANDARDS AND REPORT VERSION	3
1.1.	Test Standards	3
1.2.	Report version	3
2.	TEST DESCRIPTION	4
3.	SUMMARY	5
3.1.	Client Information	5
3.2.	Product Description	5
3.3.	Radio Specification Description	5
3.4.	Testing Laboratory Information	6
4.	TEST CONFIGURATION	7
4.1.	Test frequency list	7
4.2.	Test mode	7
4.3.	Support unit used in test configuration and system	7
4.4.	Testing environmental condition	8
4.5.	Measurement uncertainty	8
4.6.	Equipment Used during the Test	9
5.	TEST CONDITIONS AND RESULTS	11
5.1.	Antenna Requirement	11
5.2.	AC Conducted Emission	12
5.3.	Radiated Band edge Emission	15
5.4.	Radiated Spurious Emission	17
6.	TEST SETUP PHOTOS	21
7.	EXTERANAL AND INTERNAL PHOTOS	22

1. TEST STANDARDS AND REPORT VERSION

1.1. Test Standards

The tests were performed according to following standards:

- [FCC Rules Part 15.247](#): Frequency Hopping, Direct Spread Spectrum and Hybrid Systems that are in operation within the bands of 902-928 MHz, 2400-2483.5 MHz, and 5725-5850 MHz
- [ANSI C63.10:2013](#): American National Standard for Testing Unlicensed Wireless Devices
- [KDB 558074 D01 15.247 Meas Guidance v05r02](#): Guidance for Compliance Measurements on Digital Transmission System, Frequency Hopping Spread Spectrum System, and Hybrid System Devices Operating under Section 15.247 of The FCC Rules

1.2. Report version

Revision No.	Date of issue	Description
N/A	2021-10-09	We have spot check test on the product, and the result have no major different from the value in the module report, which meets the requirements of reference module certification from KDB 484596.

2. TEST DESCRIPTION

Report clause	Test Items	Standard Requirement	Result
5.1	Antenna Requirement	15.203/15.247(c)	Pass*
5.2	AC Conducted Emission	15.207	Pass
5.3	Peak Output Power	15.247(b)(3)	Pass*
5.4	Power Spectral Density	15.247(e)	Pass*
5.5	6dB Bandwidth	15.247(a)(2)	Pass*
5.6	99% Occupied Bandwidth	-	Pass ^{*1}
5.7	Duty cycle	-	Pass ^{*1}
5.8	Conducted Band Edge and Spurious Emission	15.247(d)/15.205	Pass*
5.9	Radiated Band Edge Emission	15.205/15.209	Pass
5.10	Radiated Spurious Emission	15.247(d)/15.205/15.209	Pass

Note:

- The measurement uncertainty is not included in the test result.
- *1: No requirement on standard, only report these test data.
- * reference to module report , which FCC ID is XMR202005SC200RNA

3. SUMMARY

3.1. Client Information

Applicant:	Telo Communication (Shenzhen) Co., Ltd
Address:	6/F, No.42 Liuxian 1st Road, Bao'an District, Shenzhen, China
Manufacturer:	Telo Communication (Shenzhen) Co., Ltd
Address:	6/F, No.42 Liuxian 1st Road, Bao'an District, Shenzhen, China

3.2. Product Description

Name of EUT:	TE620
Trade Mark:	TELOX, Telo Systems
Model No.:	TE620
Listed Model(s):	TELOX-TE620, Telo-TE620, TE620A, TE620B, TE620C, TE620D, TE620E, TE620F, TE620G, TE620H, TE620J, TE620K, TE620L, TE620M, TE620Q, TE620R, TE620S, TE620T, TE620U, TE620V, TE620X, TE620Y
Power supply:	DC 3.8V
Battery Information:	DC 3.8V; 5000mAh
Adapter Information:	Model: SR-D505 Input: AC100-240V, 50/60Hz, 0.3A Output: 5.0Vdc, 2.0A Manufacturer: SHENZHEN SNROX ELECTRONIC CO.,LTD
Hardware version:	TE620 V2.2
Software version:	TE620_INT_V7_20210902

3.3. Radio Specification Description

Bluetooth version:	V4.0
Support function ^{*2} :	BLE
Modulation:	GFSK
Operation frequency:	2402MHz~2480MHz
Channel number:	40
Channel separation:	2MHz
Antenna type:	PIFA Antenna
Antenna gain:	0.5dBi

Note:

*2: only show the RF function associated with this report.

3.4. Testing Laboratory Information

Laboratory Name	Shenzhen Huatongwei International Inspection Co., Ltd.	
Laboratory Location	1/F, Bldg 3, Hongfa Hi-tech Industrial Park, Genyu Road, Tianliao, Gongming, Shenzhen, China	
Connect information:	Phone: 86-755-26715499 E-mail: cs@szhtw.com.cn http://www.szhtw.com.cn	
Qualifications	Type	Accreditation Number
	FCC	762235

4. TEST CONFIGURATION

4.1. Test frequency list

According to section 15.31(m), regards to the operating frequency range over 10 MHz, must select three channels which were tested. The Lowest frequency, the middle frequency, and the highest frequency of channel were selected to perform the test, please see the below blue front.

Channel	Frequency (MHz)
00	2402
01	2404
:	:
19	2440
:	:
38	2478
39	2480

4.2. Test mode

For RF test items
The engineering test program was provided and enabled to make EUT continuous transmit.
For Radiated spurious emissions test item:
The engineering test program was provided and enabled to make EUT continuous transmit. The EUT in each of three orthogonal axis emissions had been tested, but only the worst case (X axis) data Recorded in the report.

4.3. Support unit used in test configuration and system

The EUT has been associated with peripherals and configuration operated in a manner tended to maximize its emission characteristics in a typical application.

The following peripheral devices and interface cables were connected during the measurement:

Whether support unit is used?					
✓ No					
Item	Equipement	Trade Name	Model No.	FCC ID	Power cord
1					
2					

4.4. Testing environmental condition

Type	Requirement	Actual
Temperature:	15~35°C	25°C
Relative Humidity:	25~75%	50%
Air Pressure:	860~1060mbar	1000mbar

4.5. Measurement uncertainty

Test Item	Measurement Uncertainty
AC Conducted Emission (150kHz~30MHz)	3.02 dB
Radiated Emission (30MHz~1000MHz)	4.90 dB
Radiated Emissions (1GHz~25GHz)	4.96 dB
Peak Output Power	0.51 dB
Power Spectral Density	0.51 dB
Conducted Spurious Emission	0.51 dB
6dB Bandwidth	70 Hz

This uncertainty represents an expanded uncertainty expressed at approximately the 95% confidence level using a coverage factor of $k=1.96$.

4.6. Equipment Used during the Test

● Conducted Emission							
Used	Test Equipment	Manufacturer	Equipment No.	Model No.	Serial No.	Last Cal. Date (YY-MM-DD)	Next Cal. Date (YY-MM-DD)
●	Shielded Room	Albatross projects	HTWE0114	N/A	N/A	2021/9/13	2022/9/12
●	EMI Test Receiver	R&S	HTWE0111	ESCI	101247	2021/9/13	2022/9/12
●	Artificial Mains	SCHWARZBECK	HTWE0113	NNLK 8121	573	2021/9/13	2022/9/12
●	Pulse Limiter	R&S	HTWE0033	ESH3-Z2	100499	2021/9/13	2022/9/12
●	RF Connection Cable	HUBER+SUHNER	HTWE0113-02	ENVIROFLE X_142	EF-NM-BNCM-2M	2021/9/13	2022/9/12
●	Test Software	R&S	N/A	ES-K1	N/A	N/A	N/A

● Radiated emission-6th test site							
Used	Test Equipment	Manufacturer	Equipment No.	Model No.	Serial No.	Last Cal. Date (YY-MM-DD)	Next Cal. Date (YY-MM-DD)
●	Semi-Anechoic Chamber	Albatross projects	HTWE0127	SAC-3m-02	C11121	2018/09/30	2022/09/29
●	EMI Test Receiver	R&S	HTWE0099	ESCI	100900	2021/9/14	2022/9/13
●	Loop Antenna	R&S	HTWE0170	HFH2-Z2	100020	2021/04/06	2022/04/05
●	Ultra-Broadband Antenna	SCHWARZBECK	HTWE0123	VULB9163	538	2021/04/06	2022/04/05
●	Pre-Amplifier	SCHWARZBECK	HTWE0295	BBV 9742	N/A	2020/11/13	2021/11/12
●	RF Connection Cable	HUBER+SUHNER	HTWE0062-01	N/A	N/A	2021/02/26	2022/02/25
●	RF Connection Cable	HUBER+SUHNER	HTWE0062-02	SUCOFLEX104	501184/4	2021/02/26	2022/02/25
●	Test Software	R&S	N/A	ES-K1	N/A	N/A	N/A

● Radiated emission-7th test site							
Used	Test Equipment	Manufacturer	Equipment No.	Model No.	Serial No.	Last Cal. Date (YY-MM-DD)	Next Cal. Date (YY-MM-DD)
●	Semi-Anechoic Chamber	Albatross projects	HTWE0122	SAC-3m-01	N/A	2018/09/27	2022/09/26
●	Spectrum Analyzer	R&S	HTWE0098	FSP40	100597	2021/9/13	2022/9/12
●	Horn Antenna	SCHWARZBECK	HTWE0126	9120D	1011	2020/04/01	2023/03/31
●	Broadband Horn Antenna	SCHWARZBECK	HTWE0103	BBHA9170	BBHA9170472	2020/4/27	2023/4/27
●	Pre-amplifier	CD	HTWE0071	PAP-0102	12004	2020/11/13	2021/11/12
●	Broadband Pre-amplifier	SCHWARZBECK	HTWE0201	BBV 9718	9718-248	2021/03/05	2022/03/04
●	RF Connection Cable	HUBER+SUHNER	HTWE0120-01	6m 18GHz S Serisa	N/A	2021/02/26	2022/02/25
●	RF Connection Cable	HUBER+SUHNER	HTWE0120-02	6m 3GHz RG Serisa	N/A	2021/02/26	2022/02/25
●	RF Connection Cable	HUBER+SUHNER	HTWE0120-03	6m 3GHz RG Serisa	N/A	2021/02/26	2022/02/25
●	RF Connection Cable	HUBER+SUHNER	HTWE0120-04	6m 3GHz RG Serisa	N/A	2021/02/26	2022/02/25
●	RF Connection Cable	HUBER+SUHNER	HTWE0121-01	6m 18GHz S Serisa	N/A	2021/02/26	2022/02/25
●	Test Software	Audix	N/A	E3	N/A	N/A	N/A

● RF Conducted Method						
Used	Test Equipment	Manufacturer	Model No.	Serial No.	Last Cal. Date (YY-MM-DD)	Next Cal. Date (YY-MM-DD)
●	Signal and spectrum Analyzer	R&S	FSV40	100048	2020/10/19	2021/10/18
●	Spectrum Analyzer	Agilent	N9020A	MY50510187	2020/10/19	2021/10/18
●	Power Meter	Anritsu	ML249A	N/A	2020/10/19	2021/10/18
○	Radio communication tester	R&S	CMW500	137688-Lv	2020/10/19	2021/10/18

5. TEST CONDITIONS AND RESULTS

5.1. Antenna Requirement

Requirement

FCC CFR Title 47 Part 15 Subpart C Section 15.203:

An intentional radiator shall be designed to ensure that no antenna other than that furnished by the responsible party shall be used with the device. The use of a permanently attached antenna or of an antenna that uses a unique coupling to the intentional radiator, the manufacturer may design the unit so that a broken antenna can be replaced by the user, but the use of a standard antenna jack or electrical connector is prohibited.

FCC CFR Title 47 Part 15 Subpart C Section 15.247(c) (1)(i):

(i) Systems operating in the 2400-2483.5 MHz band that is used exclusively for fixed. Point-to-point operations may employ transmitting antennas with directional gain greater than 6 dBi provided the maximum conducted output power of the intentional radiator is reduced by 1 dB for every 3 dB that the directional gain of the antenna exceeds 6 dBi.

TEST RESULT

Passed **Not Applicable**

The antenna type is a PIFA antenna, the directional gain of the antenna less than 6 dBi, please refer to the below antenna photo.

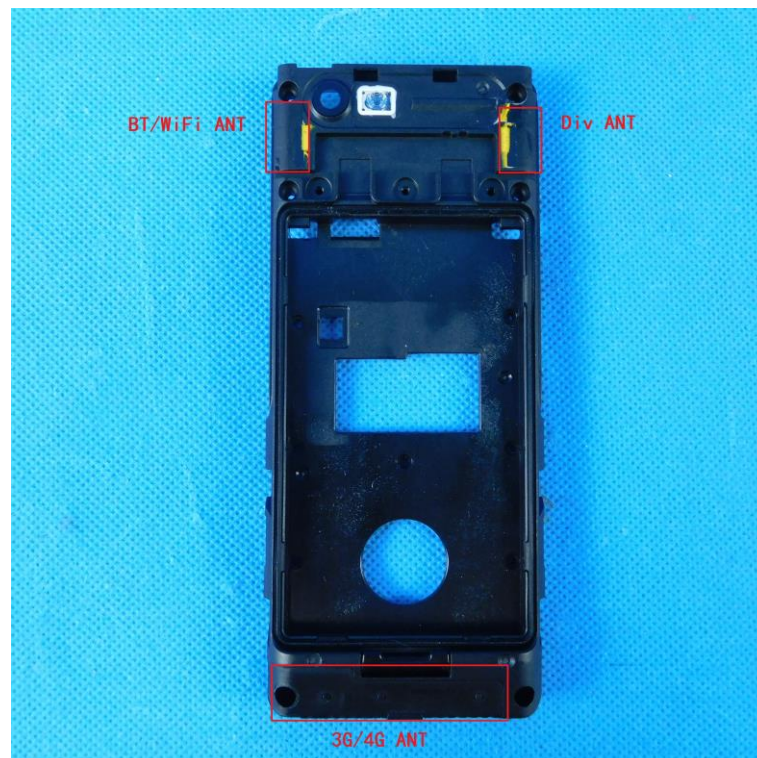

5.2. AC Conducted Emission

LIMIT

FCC CFR Title 47 Part 15 Subpart C Section 15.207

Frequency range (MHz)	Limit (dBuV)	
	Quasi-peak	Average
0.15-0.5	66 to 56*	56 to 46*
0.5-5	56	46
5-30	60	50

* Decreases with the logarithm of the frequency.

TEST CONFIGURATION

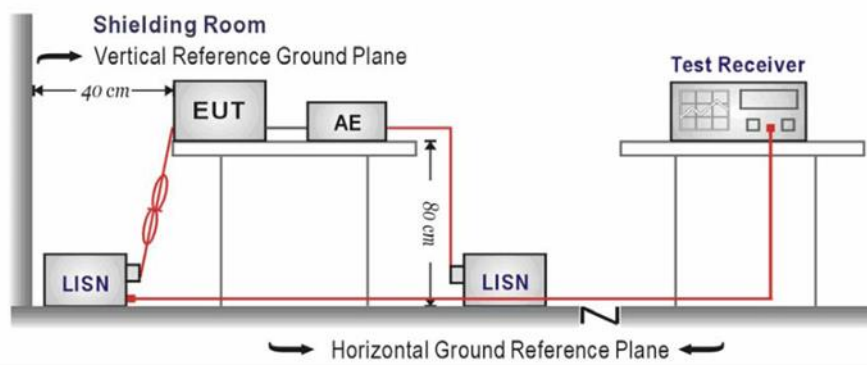

TEST PROCEDURE

1. The EUT was setup according to ANSI C63.10 requirements.
2. The EUT was placed on a platform of nominal size, 1 m by 1.5 m, raised 80 cm above the conducting ground plane. The vertical conducting plane was located 40 cm to the rear of the EUT. All other surfaces of EUT were at least 80 cm from any other grounded conducting surface.
3. The EUT and simulators are connected to the main power through a line impedances stabilization network (LISN). The LISN provides a 50 ohm /50uH coupling impedance for the measuring equipment.
4. The peripheral devices are also connected to the main power through a LISN. (Please refer to the block diagram of the test setup and photographs)
5. Each current-carrying conductor of the EUT power cord, except the ground (safety) conductor, was individually connected through a LISN to the input power source.
6. The excess length of the power cord between the EUT and the LISN receptacle were folded back and forth at the center of the lead to form a bundle not exceeding 40 cm in length.
7. Conducted emissions were investigated over the frequency range from 0.15MHz to 30MHz using a receiver bandwidth of 9 kHz.
8. During the above scans, the emissions were maximized by cable manipulation.

TEST MODE:

Please refer to the clause 4.2

TEST RESULT

Passed Not Applicable

Test Line:

L

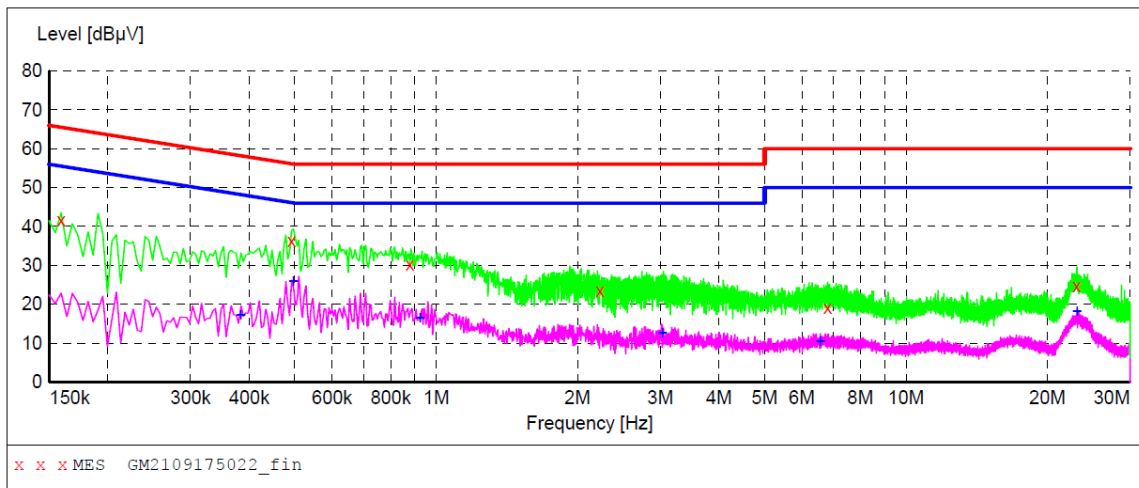

MEASUREMENT RESULT: "GM2109175022_fin"

9/17/2021 10:29AM

Frequency MHz	Level dBµV	Transd dB	Limit dBµV	Margin dB	Detector	Line	PE
0.159000	41.60	10.2	66	23.9	QP	L1	GND
0.492000	36.20	10.2	56	19.9	QP	L1	GND
0.879000	30.30	10.2	56	25.7	QP	L1	GND
2.233500	23.50	10.2	56	32.5	QP	L1	GND
6.805500	19.10	10.2	60	40.9	QP	L1	GND
23.091000	24.60	10.3	60	35.4	QP	L1	GND

MEASUREMENT RESULT: "GM2109175022_fin2"

9/17/2021 10:29AM

Frequency MHz	Level dBµV	Transd dB	Limit dBµV	Margin dB	Detector	Line	PE
0.384000	17.30	10.2	48	30.9	AV	L1	GND
0.496500	25.80	10.2	46	20.3	AV	L1	GND
0.924000	16.40	10.2	46	29.6	AV	L1	GND
3.030000	12.60	10.2	46	33.4	AV	L1	GND
6.567000	10.30	10.2	50	39.7	AV	L1	GND
23.140500	18.20	10.3	50	31.8	AV	L1	GND

Test Line:

N

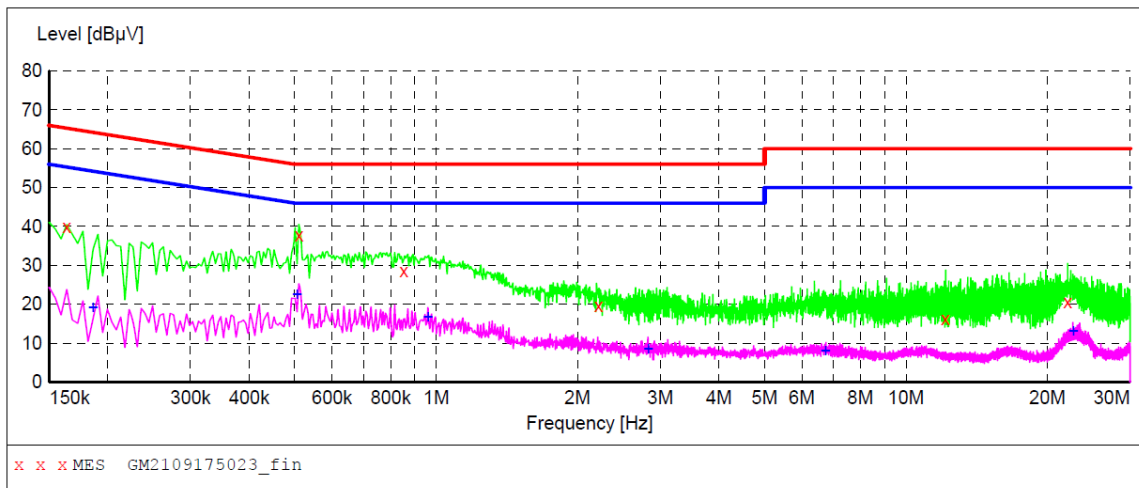

MEASUREMENT RESULT: "GM2109175023_fin"

9/17/2021 10:32AM

Frequency MHz	Level dBµV	Transd dB	Limit dBµV	Margin dB	Detector	Line	PE
0.163500	40.00	10.2	65	25.3	QP	N	GND
0.510000	37.70	10.2	56	18.3	QP	N	GND
0.852000	28.50	10.2	56	27.5	QP	N	GND
2.215500	19.70	10.2	56	36.3	QP	N	GND
12.115500	16.20	10.3	60	43.8	QP	N	GND
22.078500	20.60	10.3	60	39.4	QP	N	GND

MEASUREMENT RESULT: "GM2109175023_fin2"

9/17/2021 10:32AM

Frequency MHz	Level dBµV	Transd dB	Limit dBµV	Margin dB	Detector	Line	PE
0.186000	19.00	10.2	54	35.2	AV	N	GND
0.505500	22.40	10.2	46	23.6	AV	N	GND
0.960000	16.80	10.2	46	29.2	AV	N	GND
2.827500	8.50	10.2	46	37.5	AV	N	GND
6.738000	8.10	10.2	50	41.9	AV	N	GND
22.708500	13.10	10.3	50	36.9	AV	N	GND

5.3. Radiated Band edge Emission

LIMIT

FCC CFR Title 47 Part 15 Subpart C Section 15.247 (d):

In any 100 kHz bandwidth outside the frequency band in which the spread spectrum or digitally modulated intentional radiator is operating, Radiated Emissions which fall in the restricted bands, as defined in §15.205(a), must also comply with the Radiated Emissions limits specified in §15.209(a) (see §15.205(c)).

TEST CONFIGURATION

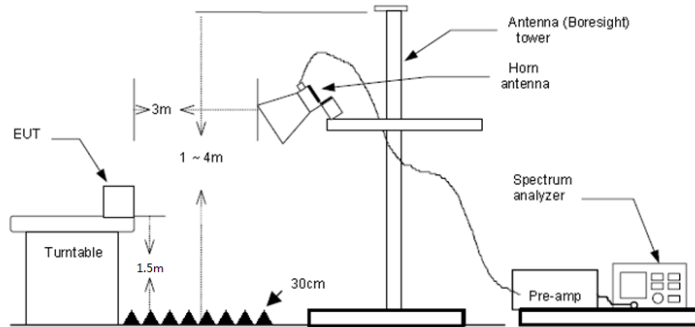

TEST PROCEDURE

1. The EUT was setup and tested according to ANSI C63.10 .
2. The EUT is placed on a turn table which is 1.5 meter above ground. The turn table is rotated 360 degrees to determine the position of the maximum emission level.
3. The EUT was positioned such that the distance from antenna to the EUT was 3 meters.
4. The antenna is scanned from 1 meter to 4 meters to find out the maximum emission level. This is repeated for both horizontal and vertical polarization of the antenna. In order to find the maximum emission, all of the interface cables were manipulated according to ANSI C63.10 on radiated measurement.
5. Use the following spectrum analyzer settings:
 - a) Span shall wide enough to fully capture the emission being measured
 - b) Set RBW=100kHz for <1GHz, VBW=3*RBW, Sweep time=auto, Detector=peak, Trace=max hold
 - c) Set RBW=1MHz, VBW=3MHz for >1GHz, Sweep time=auto, Detector=peak, Trace=max hold for Peak measurement

For average measurement:

 - VBW=10Hz, When duty cycle is no less than 98 percent
 - VBW≥1/T, when duty cycle is less than 98 percent where T is the minimum transmission duration over which the transmitter is on and is transmitting at its maximum power control level for the tested mode of operation, so refer to this clause 5.6 duty cycle.

TEST MODE:

Please refer to the clause 4.2

TEST RESULT

Passed Not Applicable

Note:

- 1) Level= Reading + Factor; Factor =Antenna Factor+ Cable Loss- Preamp Factor
- 2) Over Limit = Level- Limit
- 3) Average measurement was not performed if peak level is lower than average limit(54 dBuV/m).

Test channel		CH00			Polarity			Horizontal		
Mark	Frequency MHz	Reading dBuV/m	Antenna dB	Cable dB	Preamp dB	Level dBuV/m	Limit dBuV/m	Over limit	Remark	
1	2310.00	38.53	27.96	5.43	37.56	54.36	74.00	-19.64	Peak	
2	2390.03	37.47	27.72	5.53	37.45	53.27	74.00	-20.73	Peak	
Mark	Frequency MHz	Reading dBuV/m	Antenna dB	Cable dB	Preamp dB	Level dBuV/m	Limit dBuV/m	Over limit	Remark	
1	2310.00	26.51	27.96	5.43	37.56	42.34	54.00	-11.66	Average	
2	2390.03	26.64	27.72	5.53	37.45	42.44	54.00	-11.56	Average	

Test channel		CH00			Polarity			Vertical		
Mark	Frequency MHz	Reading dBuV/m	Antenna dB	Cable dB	Preamp dB	Level dBuV/m	Limit dBuV/m	Over limit	Remark	
1	2310.00	38.42	27.96	5.43	37.56	54.25	74.00	-19.75	Peak	
2	2390.03	37.41	27.72	5.53	37.45	53.21	74.00	-20.79	Peak	
Mark	Frequency MHz	Reading dBuV/m	Antenna dB	Cable dB	Preamp dB	Level dBuV/m	Limit dBuV/m	Over limit	Remark	
1	2310.00	26.63	27.96	5.43	37.56	42.46	54.00	-11.54	Average	
2	2390.03	26.47	27.72	5.53	37.45	42.27	54.00	-11.73	Average	

Test channel		CH39			Polarity			Horizontal		
Mark	Frequency MHz	Reading dBuV/m	Antenna dB	Cable dB	Preamp dB	Level dBuV/m	Limit dBuV/m	Over limit	Remark	
1	2483.50	26.49	27.43	5.64	37.26	42.30	54.00	-11.70	Average	
2	2500.00	26.23	27.40	5.66	37.26	42.03	54.00	-11.97	Average	
Mark	Frequency MHz	Reading dBuV/m	Antenna dB	Cable dB	Preamp dB	Level dBuV/m	Limit dBuV/m	Over limit	Remark	
1	2483.50	37.67	27.43	5.64	37.26	53.48	74.00	-20.52	Peak	
2	2500.00	37.07	27.40	5.66	37.26	52.87	74.00	-21.13	Peak	

Test channel		CH39			Polarity			Vertical		
Mark	Frequency MHz	Reading dBuV/m	Antenna dB	Cable dB	Preamp dB	Level dBuV/m	Limit dBuV/m	Over limit	Remark	
1	2483.50	26.41	27.43	5.64	37.26	42.22	54.00	-11.78	Average	
2	2500.00	26.25	27.40	5.66	37.26	42.05	54.00	-11.95	Average	
Mark	Frequency MHz	Reading dBuV/m	Antenna dB	Cable dB	Preamp dB	Level dBuV/m	Limit dBuV/m	Over limit	Remark	
1	2483.50	38.96	27.43	5.64	37.26	54.77	74.00	-19.23	Peak	
2	2500.00	37.36	27.40	5.66	37.26	53.16	74.00	-20.84	Peak	

5.4. Radiated Spurious Emission

LIMIT

FCC CFR Title 47 Part 15 Subpart C Section 15.209

Frequency	Limit (dBuV/m)	Value
0.009 MHz ~0.49 MHz	2400/F(kHz) @300m	Quasi-peak
0.49 MHz ~ 1.705 MHz	24000/F(kHz) @30m	Quasi-peak
1.705 MHz ~30 MHz	30 @30m	Quasi-peak

Note: Limit dBuV/m @3m = Limit dBuV/m @300m + 40*log(300/3)= Limit dBuV/m @300m +80,

Limit dBuV/m @3m = Limit dBuV/m @30m +40*log(30/3)= Limit dBuV/m @30m + 40.

Frequency	Limit (dBuV/m @3m)	Value
30MHz~88MHz	40.00	Quasi-peak
88MHz~216MHz	43.50	Quasi-peak
216MHz~960MHz	46.00	Quasi-peak
960MHz~1GHz	54.00	Quasi-peak
Above 1GHz	54.00	Average
	74.00	Peak

TEST CONFIGURATION

- 9 kHz ~ 30 MHz

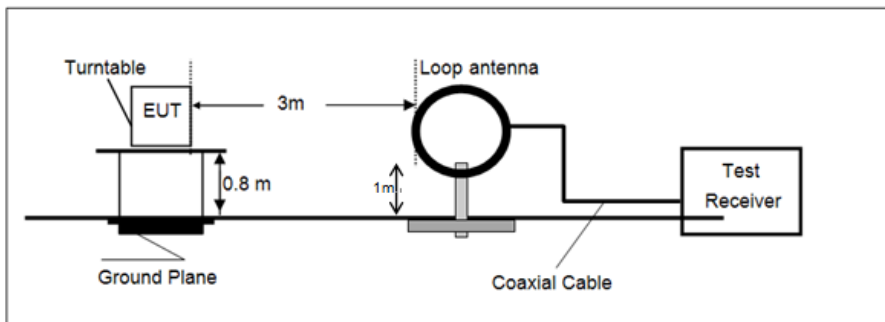

- 30 MHz ~ 1 GHz

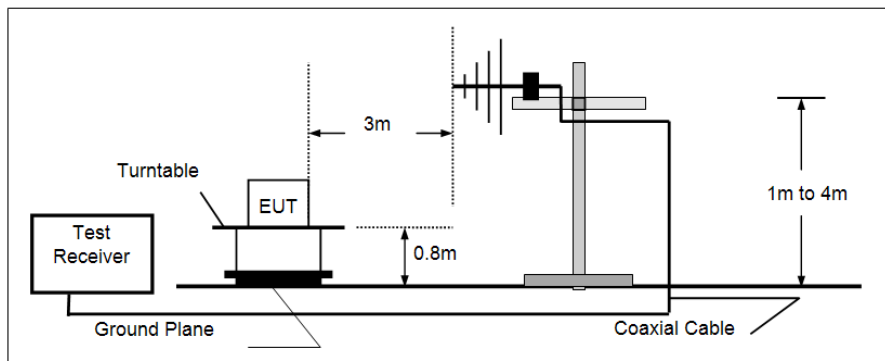

- Above 1 GHz

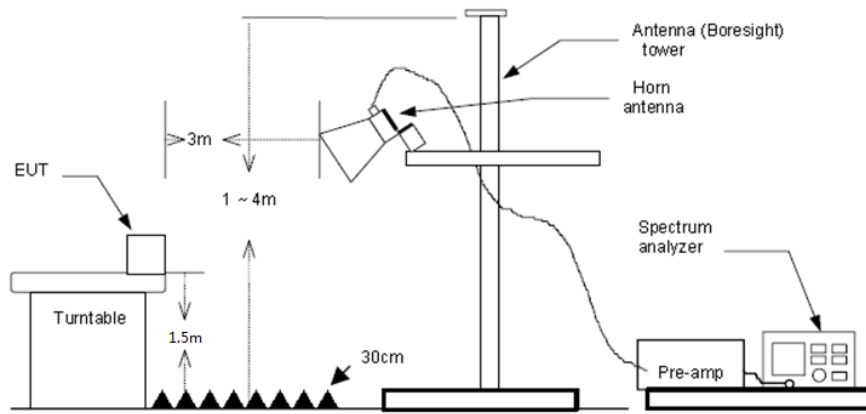

TEST PROCEDURE

1. The EUT was setup and tested according to ANSI C63.10 .
2. The EUT is placed on a turn table which is 0.8 meter above ground for below 1 GHz, and 1.5 m for above 1 GHz. The turn table is rotated 360 degrees to determine the position of the maximum emission level.
3. The EUT was set 3 meters from the receiving antenna, which was mounted on the top of a variable height antenna tower.
4. For each suspected emission, the EUT was arranged to its worst case and then tune the Antenna tower (from 1 m to 4 m) and turntable (from 0 degree to 360 degrees) to find the maximum reading. A pre-amp and a high pass filter are used for the test in order to get better signal level to comply with the guidelines.
5. Set to the maximum power setting and enable the EUT transmit continuously.
6. Use the following spectrum analyzer settings
 - a) Span shall wide enough to fully capture the emission being measured;
 - b) Below 1 GHz:
 - RBW=120 kHz, VBW=300 kHz, Sweep=auto, Detector function=peak, Trace=max hold;
 - If the emission level of the EUT measured by the peak detector is 3 dB lower than the applicable limit, the peak emission level will be reported. Otherwise, the emission measurement will be repeated using the quasi-peak detector and reported.
 - c) Set RBW=1MHz, VBW=3MHz for >1GHz, Sweep time=auto, Detector=peak, Trace=max hold for Peak measurement
 - For average measurement:
 - VBW=10Hz, When duty cycle is no less than 98 percent
 - $VBW \geq 1/T$, when duty cycle is less than 98 percent where T is the minimum transmission duration over which the transmitter is on and is transmitting at its maximum power control level for the tested mode of operation, so refer to this clause 5.6 duty cycle.

TEST MODE:

Please refer to the clause 4.2

TEST RESULT

Passed **Not Applicable**

Note:

- 1) Level= Reading + Factor/Transd; Factor/Transd =Antenna Factor+ Cable Loss- Preamp Factor
- 2) Over Limit = Level- Limit
- 3) Average measurement was not performed if peak level is lower than average limit(54 dBuV/m) for above 1GHz.

TEST DATA FOR 9 kHz ~ 30 MHz

The EUT was pre-scanned this frequency band, found the radiated level 20dB lower than the limit, so don't show data on this report.

TEST DATA FOR 30 MHz ~ 1000 MHz

Have pre-scan all test channel, found CH39 which it was worst case, so only show the worst case's data on this report.

Polarization:

Horizontal

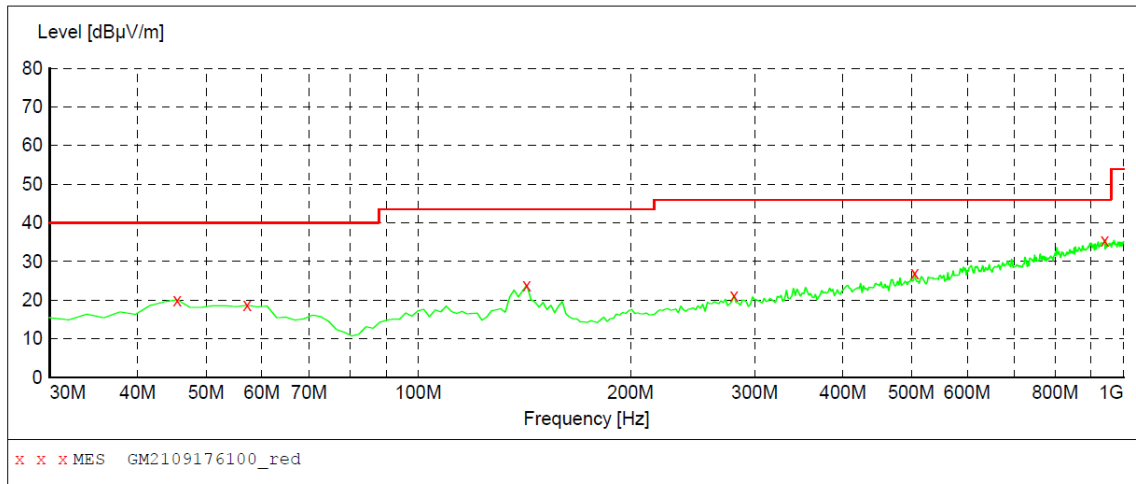

MEASUREMENT RESULT: "GM2109176100_red"

9/17/2021 5:32PM

Frequency MHz	Level dBµV/m	Transd dB	Limit dBµV/m	Margin dB	Det.	Height cm	Azimuth deg	Polarization
45.520000	20.10	-8.8	40.0	19.9	QP	100.0	38.00	HORIZONTAL
57.160000	18.70	-9.4	40.0	21.3	QP	100.0	236.00	HORIZONTAL
142.520000	23.90	-14.2	43.5	19.6	QP	100.0	322.00	HORIZONTAL
280.260000	21.10	-7.7	46.0	24.9	QP	100.0	209.00	HORIZONTAL
505.300000	27.10	-1.4	46.0	18.9	QP	100.0	236.00	HORIZONTAL
939.860000	35.60	7.7	46.0	10.4	QP	100.0	50.00	HORIZONTAL

Polarization:

Vertical

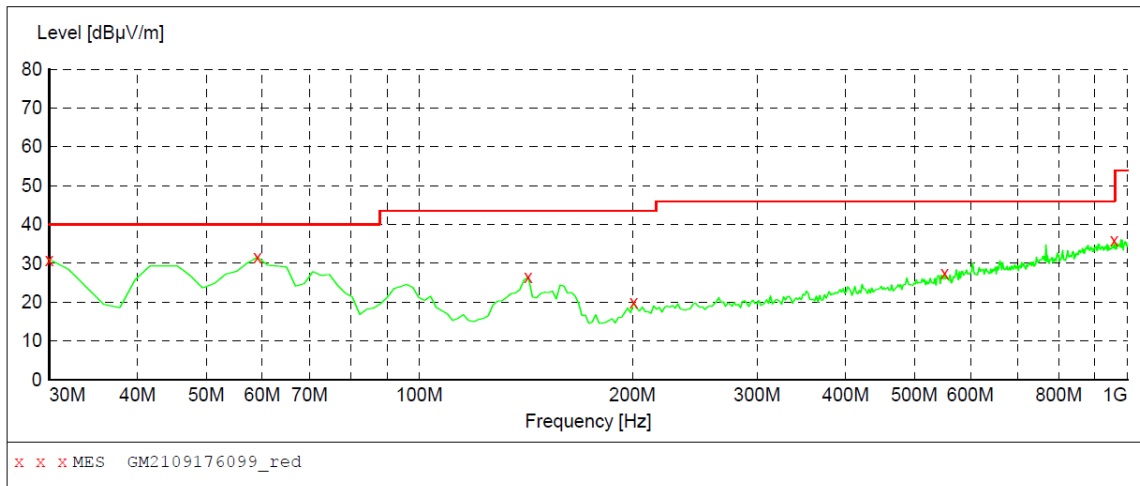

MEASUREMENT RESULT: "GM2109176099_red"

9/17/2021 5:29PM

Frequency MHz	Level dBµV/m	Transd dB	Limit dBµV/m	Margin dB	Det.	Height cm	Azimuth deg	Polarization
30.000000	31.00	-12.4	40.0	9.0	QP	100.0	149.00	VERTICAL
59.100000	31.60	-9.7	40.0	8.4	QP	100.0	323.00	VERTICAL
142.520000	26.50	-14.2	43.5	17.0	QP	100.0	149.00	VERTICAL
200.720000	19.90	-10.0	43.5	23.6	QP	100.0	48.00	VERTICAL
551.860000	27.40	-0.3	46.0	18.6	QP	100.0	98.00	VERTICAL
957.320000	35.90	7.9	46.0	10.1	QP	100.0	10.00	VERTICAL

TEST DATA FOR 1 GHz ~ 25 GHz

Test channel		CH00			Polarity		Horizontal		
Mark	Frequency MHz	Reading dBuV/m	Antenna dB	Cable dB	Preamp dB	Level dBuV/m	Limit dBuV/m	Over limit	Remark
1	3143.98	39.59	29.00	6.37	37.21	37.75	74.00	-36.25	Peak
2	5086.52	35.05	32.20	8.92	35.46	40.71	74.00	-33.29	Peak
3	8187.50	32.83	36.77	11.24	33.47	47.37	74.00	-26.63	Peak
4	10888.51	31.87	40.57	12.52	36.76	48.20	74.00	-25.80	Peak
Test channel		CH00			Polarity		Vertical		
Mark	Frequency MHz	Reading dBuV/m	Antenna dB	Cable dB	Preamp dB	Level dBuV/m	Limit dBuV/m	Over limit	Remark
1	3143.98	40.40	29.00	6.37	37.21	38.56	74.00	-35.44	Peak
2	5762.24	40.48	31.92	9.57	34.86	47.11	74.00	-26.89	Peak
3	8002.06	32.90	37.10	10.91	33.31	47.60	74.00	-26.40	Peak
4	11545.04	31.95	40.76	12.75	36.37	49.09	74.00	-24.91	Peak

Test channel		CH19			Polarity		Horizontal		
Mark	Frequency MHz	Reading dBuV/m	Antenna dB	Cable dB	Preamp dB	Level dBuV/m	Limit dBuV/m	Over limit	Remark
1	3149.75	40.81	29.00	6.38	37.19	39.00	74.00	-35.00	Peak
2	5596.62	34.15	31.89	9.43	35.14	40.33	74.00	-33.67	Peak
3	8068.51	32.48	37.20	11.10	33.32	47.46	74.00	-26.54	Peak
4	11391.56	32.37	40.58	12.69	36.43	49.21	74.00	-24.79	Peak
Test channel		CH19			Polarity		Vertical		
Mark	Frequency MHz	Reading dBuV/m	Antenna dB	Cable dB	Preamp dB	Level dBuV/m	Limit dBuV/m	Over limit	Remark
1	3141.53	40.64	29.00	6.37	37.22	38.79	74.00	-35.21	Peak
2	4834.80	34.96	31.40	8.54	35.20	39.70	74.00	-34.30	Peak
3	8047.46	32.69	37.19	11.03	33.31	47.60	74.00	-26.40	Peak
4	11481.20	32.36	40.84	12.73	36.38	49.55	74.00	-24.45	Peak

Test channel		CH39			Polarity		Horizontal		
Mark	Frequency MHz	Reading dBuV/m	Antenna dB	Cable dB	Preamp dB	Level dBuV/m	Limit dBuV/m	Over limit	Remark
1	3143.98	40.51	29.00	6.37	37.21	38.67	74.00	-35.33	Peak
2	5762.24	35.63	31.92	9.57	34.86	42.26	74.00	-31.74	Peak
3	8083.96	31.50	37.20	11.15	33.32	46.53	74.00	-27.47	Peak
4	9734.78	33.63	39.60	11.68	36.41	48.50	74.00	-25.50	Peak
Test channel		CH39			Polarity		Vertical		
Mark	Frequency MHz	Reading dBuV/m	Antenna dB	Cable dB	Preamp dB	Level dBuV/m	Limit dBuV/m	Over limit	Remark
1	3135.99	40.97	29.00	6.36	37.25	39.08	74.00	-34.92	Peak
2	5086.52	34.87	32.20	8.92	35.46	40.53	74.00	-33.47	Peak
3	5762.24	40.19	31.92	9.57	34.86	46.82	74.00	-27.18	Peak
4	10534.09	32.90	40.03	12.47	37.06	48.34	74.00	-25.66	Peak

6. TEST SETUP PHOTOS

Radiated Emission

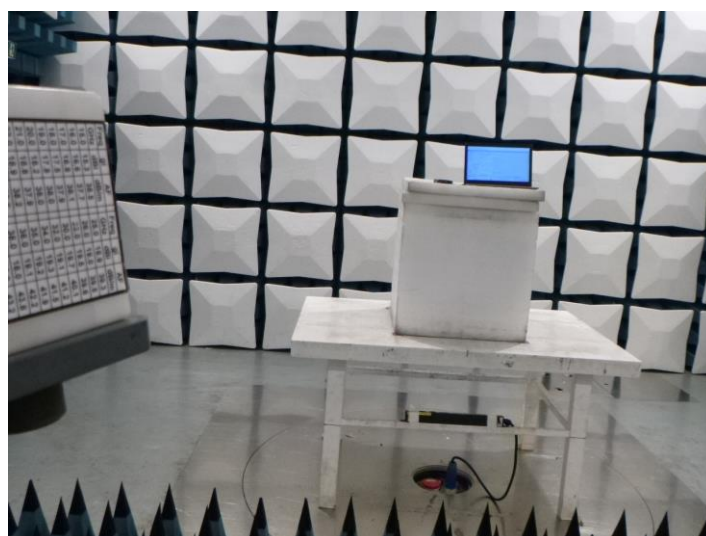

AC Conducted Emission



7. EXTERANAL AND INTERNAL PHOTOS

Reference to the test report No. : CHTEW21100001..

-----END OF REPORT-----