

FCC Radio Test Report

FCC ID: XMR202005SC200RNA

This report concerns: Original Grant

Project No. : 2005H018
Equipment : Multi-mode Smart LTE Module
Brand Name : Quectel
Test Model : SC200R-NA
Series Model : N/A
Applicant : Quectel Wireless Solutions Co., Ltd.
Address : Building 5, Shanghai Business Park Phase III (Area B), No.1016 Tianlin Road, Minhang District, Shanghai, China 200233.
Manufacturer : Quectel Wireless Solutions Co., Ltd.
Address : Building 5, Shanghai Business Park Phase III (Area B), No.1016 Tianlin Road, Minhang District, Shanghai, China 200233.
Date of Receipt : May 08, 2020
Date of Test : May 08, 2020 ~ Jun. 05, 2020
Issued Date : Aug. 10, 2020
Report Version : R00
Test Sample : Engineering Sample No.: SH2020050840, SH2020050840-1
Standard(s) : 47 CFR FCC Part 24 Subpart E
47 CFR FCC Part 2
ANSI/TIA/EIA-603-E-2016
FCC KDB 971168 D01 Power Meas License Digital Systems v03r01

The above equipment has been tested and found compliance with the requirement of the relative standards by BTL Inc.

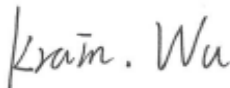

Prepared by : Krain Wu

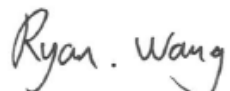

Approved by : Ryan Wang



Certificate # 5123.03

Add: No. 29, Jintang Road, Tangzhen Industry Park, Pudong New Area, Shanghai 201210, China
TEL: +86-021-61765666
Web: www.newbtl.com

Declaration

BTL represents to the client that testing is done in accordance with standard procedures as applicable and that test instruments used has been calibrated with standards traceable to international standard(s) and/or national standard(s).

BTL's reports apply only to the specific samples tested under conditions. It is manufacture's responsibility to ensure that additional production units of this model are manufactured with the identical electrical and mechanical components. **BTL** shall have no liability for any declarations, inferences or generalizations drawn by the client or others from **BTL** issued reports.

The report must not be used by the client to claim product certification, approval, or endorsement by NIST, A2LA, or any agency of the U.S. Government.

This report is the confidential property of the client. As a mutual protection to the clients, the public and ourselves, the test report shall not be reproduced, except in full, without our written approval.

BTL's laboratory quality assurance procedures are in compliance with the **ISO/IEC 17025** requirements, and accredited by the conformity assessment authorities listed in this test report.

BTL is not responsible for the sampling stage, so the results only apply to the sample as received.

The information, data and test plan are provided by manufacturer which may affect the validity of results, so it is manufacturer's responsibility to ensure that the apparatus meets the essential requirements of applied standards and in all the possible configurations as representative of its intended use.

Limitation

For the use of the authority's logo is limited unless the Test Standard(s)/Scope(s)/Item(s) mentioned in this test report is (are) included in the conformity assessment authorities acceptance respective.

Please note that the measurement uncertainty is provided for informational purpose only and is not use in determining the Pass/Fail results.

Table of Contents	Page
REPORT ISSUED HISTORY	5
1 . SUMMARY OF TEST RESULTS	6
1.1 TEST FACILITY	7
1.2 MEASUREMENT UNCERTAINTY	7
1.3 TEST ENVIRONMENT CONDITIONS	7
2 . GENERAL INFORMATION	8
2.1 GENERAL DESCRIPTION OF EUT	8
2.2 DESCRIPTION OF TEST MODES AND TEST CONDITION	10
2.3 BLOCKDIGRAMSHOWINGTHECONFIGURATIONOFSYSTEMTESTED	15
2.4 DESCRIPTION OF SUPPORT UNITS	15
3 . TEST RESULT	16
3.1 OUTPUT POWER MEASUREMENT	16
3.1.1 LIMIT	16
3.1.2 TEST PROCEDURE	16
3.1.3 TEST SETUP LAYOUT	16
3.1.4 TEST DEVIATION	16
3.1.5 TEST RESULTS	16
3.2 OCCUPIED BANDWIDTH MEASUREMENT	17
3.2.1 TEST PROCEDURE	17
3.2.2 TEST SETUP LAYOUT	17
3.2.3 TEST DEVIATION	17
3.2.4 TEST RESULTS	17
3.3 CONDUCTED EMISSIONS MEASUREMENT	18
3.3.1 LIMIT	18
3.3.2 TEST PROCEDURES	18
3.3.3 TEST SETUP LAYOUT	18
3.3.4 TEST DEVIATION	18
3.3.5 TEST RESULTS	18
3.4 RADIATED EMISSIONS MEASUREMENT	19
3.4.1 LIMIT	19
3.4.2 TEST PROCEDURES	19
3.4.3 TEST SETUP LAYOUT	20
3.4.4 TEST DEVIATION	21
3.4.5 TEST RESULTS (9KHZ TO 30MHZ)	21
3.4.6 TEST RESULTS (30MHZ TO 1000MHZ)	21
3.4.7 TEST RESULTS (ABOVE 1000MHZ)	21
3.5 BAND EDGE MEASUREMENT	22

Table of Contents	Page
3.5.1 LIMIT	22
3.5.2 TEST PROCEDURES	22
3.5.3 TEST SETUP LAYOUT	22
3.5.4 TEST DEVIATION	22
3.5.5 TEST RESULTS	22
3.6 PEAK TO AVERAGE RATIO MEASUREMENT	23
3.6.1 LIMIT	23
3.6.2 TEST PROCEDURES	23
3.6.3 TEST SETUP LAYOUT	23
3.6.4 TEST DEVIATION	23
3.6.5 TEST RESULTS	23
3.7 FREQUENCY STABILITY MEASUREMENT	24
3.7.1 LIMIT	24
3.7.2 TEST PROCEDURES	24
3.7.3 TEST SETUP LAYOUT	24
3.7.4 TEST DEVIATION	24
3.7.5 TEST RESULTS	24
4. LIST OF MEASUREMENT EQUIPMENTS	25
APPENDIX A - OUTPUT POWER	27
APPENDIX B - OCCUPIED BANDWIDTH	40
APPENDIX C - CONDUCTED EMISSIONS	66
APPENDIX D - RADIATED SPURIOUS EMISSIONS (9KHZ TO 30MHZ)	74
APPENDIX E - RADIATED EMISSION (30MHZ TO 1GHZ)	75
APPENDIX F - RADIATED EMISSION (ABOVE 1GHZ)	82
APPENDIX G - BAND EDGE	97
APPENDIX H - PEAK TO AVERAGE RATIO	111
APPENDIX I - FREQUENCY STABILITY	125

REPORT ISSUED HISTORY

Report Version	Description	Issued Date
R00	Original Issue.	Aug. 10, 2020

1. SUMMARY OF TEST RESULTS

Test procedures according to the technical standard(s):

FCC Part 24 Subpart E& Part 2			
Standard(s) Section	Test Item	Judgment	Remark
2.1046 24.232(c)	Equivalent Isotropic Radiated Power	PASS	-----
2.1049	Occupied Bandwidth	PASS	-----
2.1051 24.238(a)	Conducted Spurious Emissions	PASS	-----
2.1053 24.238(a)	Radiated Spurious Emissions	PASS	-----
24.238(a)	Band Edge Measurements	PASS	-----
24.232(d)	Peak To Average Ratio	PASS	-----
2.1055 24.235	Frequency Stability	PASS	-----

Note:

For the verdict, the "N/A" denotes "not applicable", the "N/T" denotes "not tested".

1.1 TEST FACILITY

The test facilities used to collect the test data in this report is at the location of No. 29, Jintang Road, Tangzhen Industry Park, Pudong New Area, Shanghai 201210, China.

BTL's Test Firm Registration Number for FCC: 476765

BTL's Designation Number for FCC: CN1241

1.2 MEASUREMENT UNCERTAINTY

The measurement uncertainty figures shall be calculated according the methods described in the ETSI TR 100 028 and shall correspond to an expansion factor (coverage factor) $k=1.96$ or $k=2$ (which provide confidence levels of respectively 90% and 95.45% in the case where the distributions characterizing the actual measurement uncertainties are normal (Gaussian)).

Measurement Uncertainty for a Level of Confidence of 95 %, $U=2xUc(y)$.

The BTL measurement uncertainty as below table:

A. Radiated Measurement :

Test Site	Method	Measurement Frequency Range	Ant. H / V	U,(dB)
SH-CB01	CISPR	9KHz ~ 30MHz	V	3.79
		9KHz ~ 30MHz	H	3.57
		30MHz ~ 200MHz	V	4.12
		30MHz ~ 200MHz	H	3.20
		200MHz ~ 1,000MHz	V	3.12
		200MHz ~ 1,000MHz	H	3.18

Test Site	Method	Measurement Frequency Range	U,(dB)
SH-CB01	CISPR	1GHz ~ 6GHz	4.40
		6GHz ~ 18GHz	4.86

Test Site	Method	Measurement Frequency Range	U,(dB)
SH-CB01	CISPR	18 ~ 26.5 GHz	3.64
		26.5 ~ 40 GHz	3.78

Note: Unless specifically mentioned, the uncertainty of measurement has not been taken into account to declare the compliance or non-compliance to the specification.

1.3 TEST ENVIRONMENT CONDITIONS

Test Item	Temperature	Humidity	Test Voltage	Tested By
Output Power & EIRP	23°C	60%	DC 3.8V	Forest Li
Occupied Bandwidth	23°C	60%	DC 3.8V	Forest Li
Conducted Spurious Emissions	23°C	60%	DC 3.8V	Forest Li
Radiated Spurious Emissions	23°C	46%	DC 3.8V	Forest Li
Band Edge	23°C	60%	DC 3.8V	Forest Li
Peak to Average Ratio	23°C	60%	DC 3.8V	Forest Li
Frequency Stability	Normal and Extreme			Forest Li

2. GENERAL INFORMATION

2.1 GENERAL DESCRIPTION OF EUT

Equipment	Multi-mode Smart LTE Module	
Brand Name	Quectel	
Test Model	SC200R-NA	
Series Model	N/A	
Model Difference(s)	N/A	
Software Version	SC200RNANAR04A01	
Hardware Version	R1.0	
Power Source	DC power supply.	
Power Rating	DC 3.8V	
Antenna Type	Dipole	
Antenna Gain	WCDMA Band II	1.59dBi
	LTE Band 2	
	LTE Band 25	
Modulation Type	WCDMA	UL: QPSK DL: QPSK
	LTE	UL: QPSK,16QAM DL: QPSK,16QAM
Operation Frequency	WCDMA Band II	1852.4MHz ~ 1907.6MHz
	LTE Band 2 (Channel Bandwidth: 1.4MHz)	1850.7MHz ~ 1909.3MHz
	LTE Band 2 (Channel Bandwidth: 3MHz)	1851.5MHz ~ 1908.5MHz
	LTE Band 2 (Channel Bandwidth: 5MHz)	1852.5MHz ~ 1907.5MHz
	LTE Band 2 (Channel Bandwidth: 10MHz)	1855.0MHz ~ 1905.0MHz
	LTE Band 2 (Channel Bandwidth: 15MHz)	1857.5MHz ~ 1902.5MHz
	LTE Band 2 (Channel Bandwidth: 20MHz)	1860.0MHz ~ 1900.0MHz
	LTE Band 25 (Channel Bandwidth: 1.4MHz)	1850.7MHz ~ 1914.3MHz
	LTE Band 25 (Channel Bandwidth: 3MHz)	1851.5MHz ~ 1913.5MHz
	LTE Band 25 (Channel Bandwidth: 5MHz)	1852.5MHz ~ 1912.5MHz
	LTE Band 25 (Channel Bandwidth: 10MHz)	1855.0MHz ~ 1910.0MHz
	LTE Band 25 (Channel Bandwidth: 15MHz)	1857.5MHz ~ 1907.5MHz
LTE Band 25 (Channel Bandwidth: 20MHz)	1860.0MHz ~ 1905.0MHz	

Max. EIRP Power	WCDMA	QPSK	24.38	dBm
	LTE Band 2 (Channel Bandwidth: 1.4MHz)	QPSK	25.18	dBm
		16QAM	24.18	dBm
	LTE Band 2 (Channel Bandwidth: 3MHz)	QPSK	25.03	dBm
		16QAM	24.27	dBm
	LTE Band 2 (Channel Bandwidth: 5MHz)	QPSK	24.88	dBm
		16QAM	23.67	dBm
	LTE Band 2 (Channel Bandwidth: 10MHz)	QPSK	25.24	dBm
		16QAM	24.39	dBm
	LTE Band 2 (Channel Bandwidth: 15MHz)	QPSK	25.24	dBm
		16QAM	24.27	dBm
	LTE Band 2 (Channel Bandwidth: 20MHz)	QPSK	24.89	dBm
		16QAM	24.47	dBm
	LTE Band 25 (Channel Bandwidth: 1.4MHz)	QPSK	24.96	dBm
		16QAM	24.12	dBm
	LTE Band 25 (Channel Bandwidth: 3MHz)	QPSK	24.94	dBm
		16QAM	24.14	dBm
	LTE Band 25 (Channel Bandwidth: 5MHz)	QPSK	24.98	dBm
		16QAM	23.74	dBm
	LTE Band 25 (Channel Bandwidth: 10MHz)	QPSK	25.37	dBm
16QAM		24.10	dBm	
LTE Band 25 (Channel Bandwidth: 15MHz)	QPSK	25.39	dBm	
	16QAM	24.80	dBm	
LTE Band 25 (Channel Bandwidth: 20MHz)	QPSK	25.04	dBm	
	16QAM	24.35	dBm	

Note:

1. For a more detailed features description, please refer to the manufacturer's specifications or the user's manual.

2.2 DESCRIPTION OF TEST MODES AND TEST CONDITION

Following channel(s) was (were) selected for the final test as listed below:

WCDMA MODE			
Test Item	Available Channel	Tested Channel	Mode
EIRP	9262 to 9538	9262, 9400, 9538	WCDMA
Output Power	9262 to 9538	9262, 9400, 9538	WCDMA
Conducted Emission	9262 to 9538	9400	WCDMA
Radiated Emission	9262 to 9538	9400	WCDMA
Band Edge	9262 to 9538	9262, 9538	WCDMA
Peak to Average Ratio	9262 to 9538	9262, 9400, 9538	WCDMA
Frequency Stability	9262 to 9538	9400	WCDMA

LTE BAND 2 MODE					
Test Item	Available Channel	Tested Channel	Channel Bandwidth	Modulation	Mode
Output Power & EIRP	18607 to 19193	18607, 18900, 19193	1.4MHz	QPSK, 16QAM	1RB/3RB/6RB
	18615 to 19185	18615, 18900, 19185	3MHz	QPSK, 16QAM	1RB/8RB/15RB
	18625 to 19175	18625, 18900, 19175	5MHz	QPSK, 16QAM	1RB/12RB/25RB
	18650 to 19150	18650, 18900, 19150	10MHz	QPSK, 16QAM	1RB/25RB/50RB
	18675 to 19125	18675, 18900, 19125	15MHz	QPSK, 16QAM	1RB/36RB/75RB
	18700 to 19100	18700, 18900, 19100	20MHz	QPSK, 16QAM	1RB/50RB/100RB
Occupied Bandwidth	18607 to 19193	18607, 18900, 19193	1.4MHz	QPSK, 16QAM	6RB
	18615 to 19185	18615, 18900, 19185	3MHz	QPSK, 16QAM	15RB
	18625 to 19175	18625, 18900, 19175	5MHz	QPSK, 16QAM	25RB
	18650 to 19150	18650, 18900, 19150	10MHz	QPSK, 16QAM	50RB
	18675 to 19125	18675, 18900, 19125	15MHz	QPSK, 16QAM	75 RB
	18700 to 19100	18700, 18900, 19100	20MHz	QPSK, 16QAM	100RB
Conducted Emission	18607 to 19193	18900	1.4 MHz	QPSK	1RB
	18625 to 19175	18900	5MHz	QPSK	1RB
	18700 to 19100	18900	20MHz	QPSK	1RB
Radiated Emission	18607 to 19193	18900	1.4 MHz	QPSK	1RB
	18625 to 19175	18900	5MHz	QPSK	1RB
	18700 to 19100	18900	20MHz	QPSK	1RB
Band Edge	18607 to 19193	18607	1.4MHz	QPSK	1RB/6RB
		19193	1.4MHz	QPSK	
	18615 to 19185	18615	3MHz	QPSK	1RB/15RB
		19185	3MHz	QPSK	
	18625 to 19175	18625	5MHz	QPSK	1RB/25RB
		19175	5MHz	QPSK	
	18650 to 19150	18650	10MHz	QPSK	1RB/50RB
		19150	10MHz	QPSK	
	18675 to 19125	18675	15MHz	QPSK	1RB/75RB
		19125	15MHz	QPSK	
	18700 to 19100	18700	20MHz	QPSK	1RB/100RB
		19100	20MHz	QPSK	

LTE BAND 2 MODE					
Test Item	Available Channel	Tested Channel	Channel Bandwidth	Modulation	Mode
Peak To Average Ratio	18607 to 19193	18607, 18900, 19193	1.4MHz	QPSK, 16QAM	6RB
	18615 to 19185	18615, 18900, 19185	3MHz	QPSK, 16QAM	15RB
	18625 to 19175	18625, 18900, 19175	5MHz	QPSK, 16QAM	25RB
	18650 to 19150	18650, 18900, 19150	10MHz	QPSK, 16QAM	50RB
	18675 to 19125	18675, 18900, 19125	15MHz	QPSK, 16QAM	75 RB
	18700 to 19100	18700, 18900, 19100	20MHz	QPSK, 16QAM	100RB
Frequency Stability	18607 to 19193	18900	1.4MHz	QPSK	1RB
	18615 to 19185	18900	3MHz	QPSK	1RB
	18625 to 19175	18900	5MHz	QPSK	1RB
	18650 to 19150	18900	10MHz	QPSK	1RB
	18675 to 19125	18900	15MHz	QPSK	1RB
	18700 to 19100	18900	20MHz	QPSK	1RB

LTE BAND 25 MODE					
Test Item	Available Channel	Tested Channel	Channel Bandwidth	Modulation	Mode
Output Power & EIRP	26047 to 26683	26047, 26365, 26683	1.4MHz	QPSK, 16QAM	1RB/3RB/6RB
	26055 to 26675	26055, 26365, 26675	3MHz	QPSK, 16QAM	1RB/8RB/15RB
	26065 to 26665	26065, 26365, 26665	5MHz	QPSK, 16QAM	1RB/12RB/25RB
	26090 to 26640	26090, 26365, 26640	10MHz	QPSK, 16QAM	1RB/25RB/50RB
	26115 to 26615	26115, 26365, 26615	15MHz	QPSK, 16QAM	1RB/36RB/75RB
	26140 to 26590	26140, 26365, 26590	20MHz	QPSK, 16QAM	1RB/50RB/100RB
Occupied Bandwidth	26047 to 26683	26047, 26365, 26683	1.4MHz	QPSK, 16QAM	6RB
	26055 to 26675	26055, 26365, 26675	3MHz	QPSK, 16QAM	15RB
	26065 to 26665	26065, 26365, 26665	5MHz	QPSK, 16QAM	25RB
	26090 to 26640	26090, 26365, 26640	10MHz	QPSK, 16QAM	50RB
	26115 to 26615	26115, 26365, 26615	15MHz	QPSK, 16QAM	75 RB
	26140 to 26590	26140, 26365, 26590	20MHz	QPSK, 16QAM	100RB
Conducted Emission	26047 to 26683	26365	1.4 MHz	QPSK	1RB
	26065 to 26665	26365	5MHz	QPSK	1RB
	26140 to 26590	26365	20MHz	QPSK	1RB
Radiated Emission	26047 to 26683	26365	1.4 MHz	QPSK	1RB
	26065 to 26665	26365	5MHz	QPSK	1RB
	26140 to 26590	26365	20MHz	QPSK	1RB
Band Edge	26047 to 26683	26047	1.4MHz	QPSK	1RB/6RB
		26683	1.4MHz	QPSK	
	26055 to 26675	26055	3MHz	QPSK	1RB/15RB
		26675	3MHz	QPSK	
	26065 to 26665	26065	5MHz	QPSK	1RB/25RB
		26665	5MHz	QPSK	
	26090 to 26640	26090	10MHz	QPSK	1RB/50RB
		26640	10MHz	QPSK	
	26115 to 26615	26115	15MHz	QPSK	1RB/75RB
		26615	15MHz	QPSK	
	26140 to 26590	26140	20MHz	QPSK	1RB/100RB
		26590	20MHz	QPSK	

LTE BAND 25 MODE					
Test Item	Available Channel	Tested Channel	Channel Bandwidth	Modulation	Mode
Peak To Average Ratio	26047 to 26683	26047, 26365, 26683	1.4MHz	QPSK, 16QAM	6RB
	26055 to 26675	26055, 26365, 26675	3MHz	QPSK, 16QAM	15RB
	26065 to 26665	26065, 26365, 26665	5MHz	QPSK, 16QAM	25RB
	26090 to 26640	26090, 26365, 26640	10MHz	QPSK, 16QAM	50RB
	26115 to 26615	26115, 26365, 26615	15MHz	QPSK, 16QAM	75 RB
	26140 to 26590	26140, 26365, 26590	20MHz	QPSK, 16QAM	100RB
Frequency Stability	26047 to 26683	26365	1.4MHz	QPSK	1RB
	26055 to 26675	26365	3MHz	QPSK	1RB
	26065 to 26665	26365	5MHz	QPSK	1RB
	26090 to 26640	26365	10MHz	QPSK	1RB
	26115 to 26615	26365	15MHz	QPSK	1RB
	26140 to 26590	26365	20MHz	QPSK	1RB

2.3 BLOCKDIGRAMSHOWINGTHECONFIGURATIONOFSYSTEMTESTED

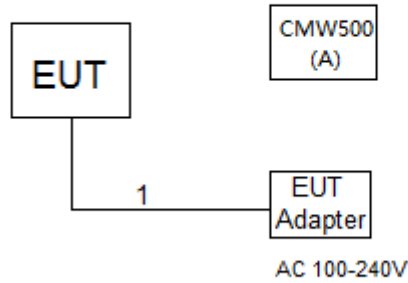

2.4 DESCRIPTION OF SUPPORT UNITS

The EUT has been tested as an independent unit together with other necessary accessories or support units. The following support units or accessories were used to form a representative test configuration during the tests.

Item	Equipment	Mfr/Brand	Model/Type No.	Series No.
1	CMW500	N/A	N/A	131463

Item	Cable Type	Shielded Type	Ferrite Core	Length
1	DC Cable	N/A	N/A	1.5m

3. TEST RESULT

3.1 OUTPUT POWER MEASUREMENT

3.1.1 LIMIT

Mobile / Portable station are limited to 2 watts e.i.r.p.

3.1.2 TEST PROCEDURE

The testing follows FCC KDB 971168 v03r01 Section 5.

EIRP:

$EIRP = \text{Output Power} + \text{Antenan gain}$

Output Power:

The EUT was set up for the maximum power with WCDMA and LTE link data modulation and link up with simulator. Set the EUT to transmit under low, middle and high channel and record the power level shown on simulator.

3.1.3 TEST SETUP LAYOUT

Output Power Measurement

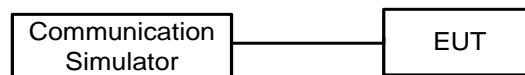

3.1.4 TEST DEVIATION

No deviation

3.1.5 TEST RESULTS

Please refer to the Appendix A.

3.2 OCCUPIED BANDWIDTH MEASUREMENT

3.2.1 TEST PROCEDURE

The testing follows FCC KDB 971168 v03r01 Section 4.

1. The EUT makes a call to the communication simulator. All measurements were done at low, middle and high operational frequency range. The communication simulator station system controlled a EUT to export maximum output power under transmission mode and specific channel frequency. Use OBW measurement function of Spectrum analyzer to measure 99 % occupied bandwidth and 26dB bandwidth.
2. The EUT was connected to spectrum analyzer and system simulator via a power divider.
3. $RBW=(1\% \sim 5\%)*EBW$
 $VBW \geq 3*RBW$
4. Set spectrum analyzer with Peak detector.

3.2.2 TEST SETUP LAYOUT

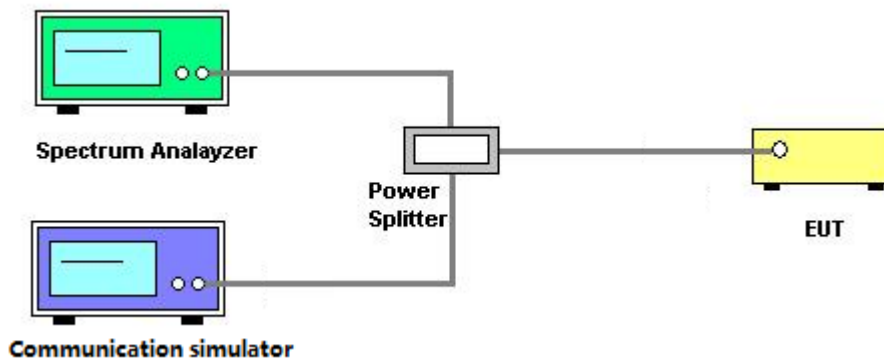

3.2.3 TEST DEVIATION

No deviation

3.2.4 TEST RESULTS

Please refer to the Appendix B.

3.3 CONDUCTED EMISSIONS MEASUREMENT

3.3.1 LIMIT

The power of any emission outside of the authorized operating frequency ranges must be attenuated below the transmitting power (P) by a factor of at least $43 + 10 \log(P)$ dB. The emission limit equal to -13dBm.

3.3.2 TEST PROCEDURES

The testing follows FCC KDB 971168 v03r01 Section 6.0.

1. The EUT was connected to spectrum analyzer and system simulator via a power divider.
2. The band edges of low and high channels for the highest RF powers were measured. Set RBW \geq 1% EBW in the 1MHz band immediately outside and adjacent to the band edge.
3. Set spectrum analyzer with RMS detector.
4. The RF fundamental frequency should be excluded against the limit line in the operating frequency band.

3.3.3 TEST SETUP LAYOUT

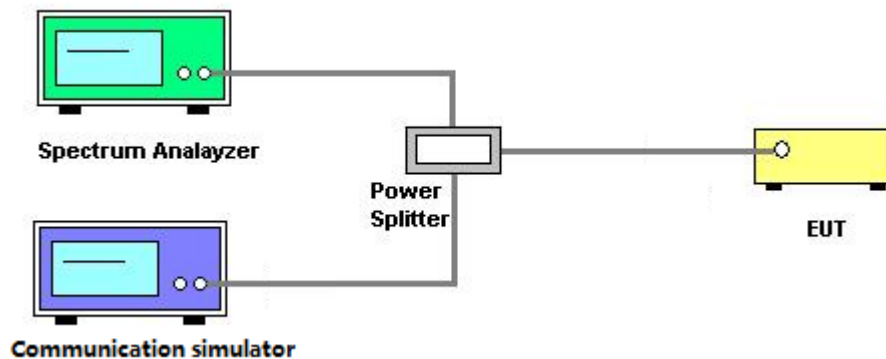

3.3.4 TEST DEVIATION

No deviation

3.3.5 TEST RESULTS

Please refer to the Appendix C.

3.4 RADIATED EMISSIONS MEASUREMENT

3.4.1 LIMIT

The power of any emission outside of the authorized operating frequency ranges must be attenuated below the transmitting power (P) by a factor of at least $43 + 10 \log(P)$ dB. The emission limit equal to -13dBm.

3.4.2 TEST PROCEDURES

The testing follows FCC KDB 971168 v03r01 Section 6.2.

1. In the semi-anechoic chamber, EUT placed on the 0.8m height of Turn Table, rotated the table around 360 degrees to search the maximum radiation power and receiver antenna shall be rotated vertical and horizontal polarization and moved height from 1m to 4m to find the maximum polar radiated power. The "Read Value" is the spectrum reading the maximum power value.
2. The substitution horn antenna is substituted for EUT at the same position and signals generator export the CW signal to the substitution antenna via a TX cable. Rotated the Turn Table and moved receiving antenna to find the maximum radiation power. Adjust output power level of S.G to get a Value of spectrum reading equal to "Read Value " of step a. Record the power level of S.G
3. $EIRP = \text{Output power level of S.G} - \text{TX cable loss} + \text{Antenna gain of substitution horn.}$
4. E.R.P power can be calculated form E.I.R.P power by subtracting the gain of dipole, $E.R.P \text{ power} = E.I.P.R \text{ power} - 2.15\text{dBi.}$
5. The resolution bandwidth and video bandwidth of test receiver/spectrum analyzer is 1MHz/3MHz.

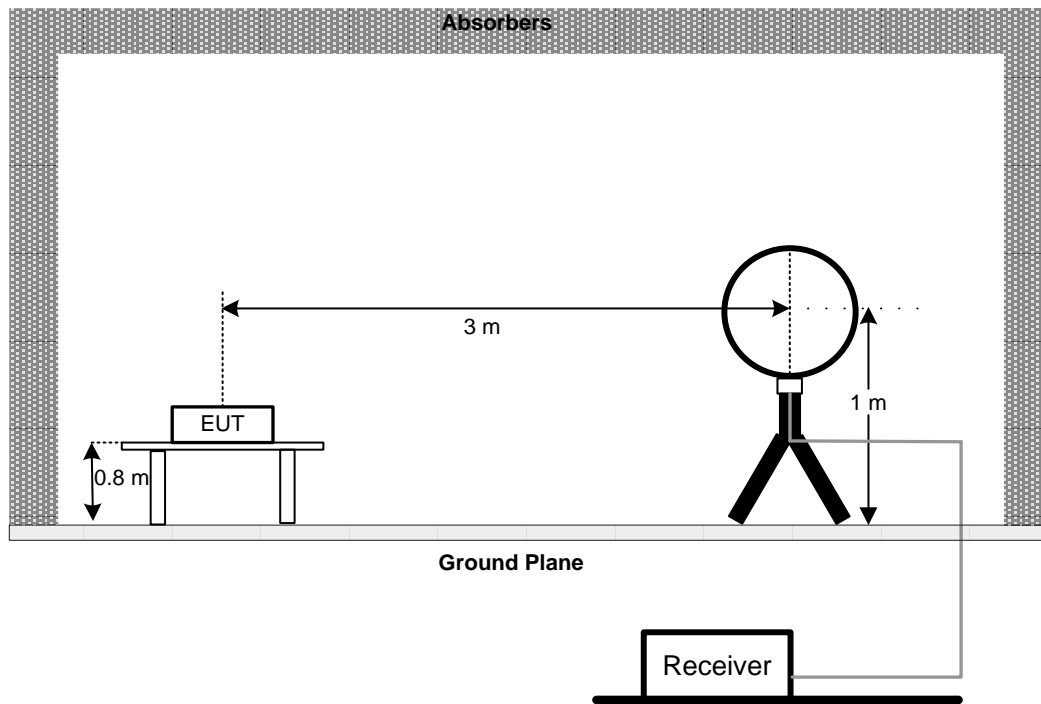
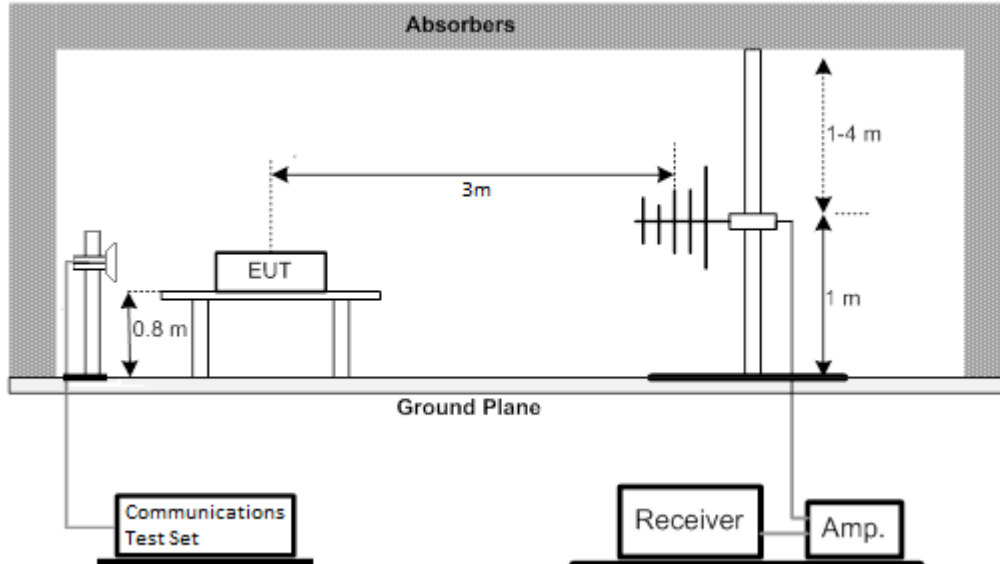
3.4.3 TEST SETUP LAYOUT**Below 30MHz****30MHz to 1GHz**

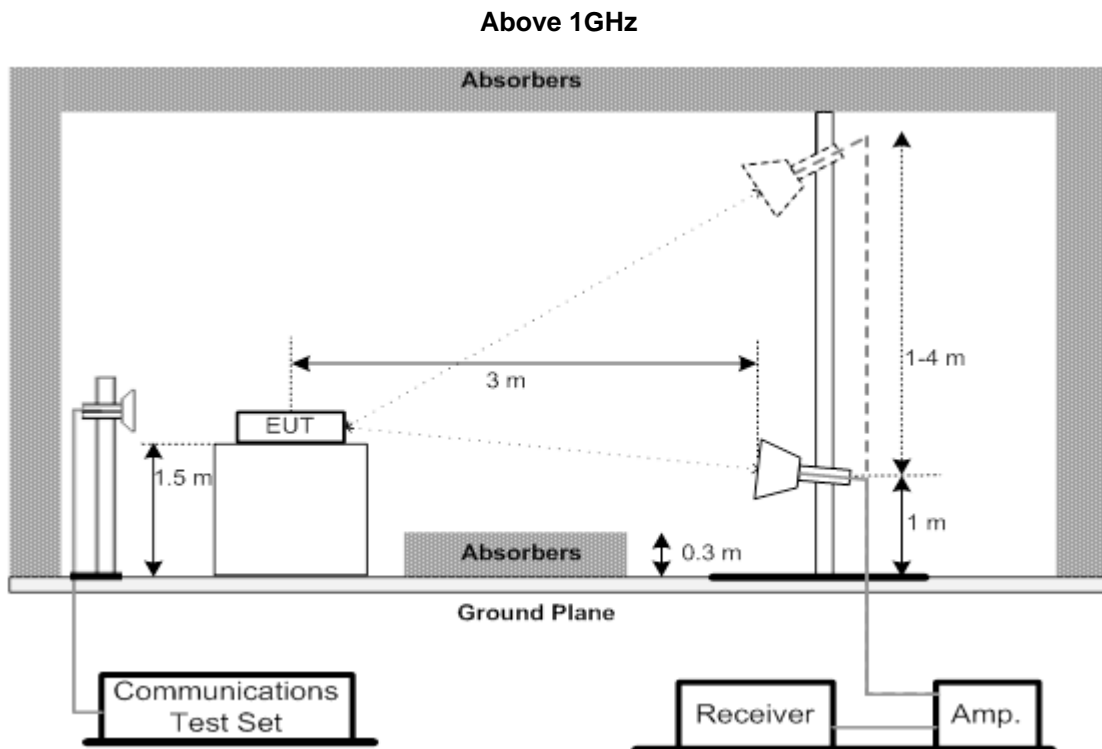

3.4.4 TEST DEVIATION

No deviation

3.4.5 TEST RESULTS (9KHZ TO 30MHZ)

Please refer to the APPENDIX D.

3.4.6 TEST RESULTS (30MHZ TO 1000MHZ)

Please refer to the APPENDIX E.

3.4.7 TEST RESULTS (ABOVE 1000MHZ)

Please refer to the APPENDIX F.

3.5 BAND EDGE MEASUREMENT

3.5.1 LIMIT

A Power of any emission outside of the authorized operating frequency ranges must be attenuated below the transmitting power (P) by a factor of at least $43 + 10 \log(P)$ dB. In the 1 MHz bands immediately outside and adjacent to the frequency block a resolution bandwidth of at least one percent of the emission bandwidth of the fundamental emission of the transmitter may be employed.

3.5.2 TEST PROCEDURES

The testing follows FCC KDB 971168 v03r01 Section 6.

1. All measurements were done at low and high operational frequency range.
2. The center frequency of spectrum is the band edge frequency and span is 2MHz. RB of the spectrum is 15kHz and VB of the spectrum is 43kHz (LTE Bandwidth 1.4MHz).
3. The center frequency of spectrum is the band edge frequency and span is 2MHz. RB of the spectrum is 30kHz and VB of the spectrum is 91kHz (LTE Bandwidth 3MHz).
4. The center frequency of spectrum is the band edge frequency and span is 2MHz. RB of the spectrum is 51kHz and VB of the spectrum is 150kHz (LTE Bandwidth 5MHz).
5. The center frequency of spectrum is the band edge frequency and span is 2MHz. RB of the spectrum is 100kHz and VB of the spectrum is 300kHz (LTE Bandwidth 10MHz).
6. The center frequency of spectrum is the band edge frequency and span is 2MHz. RB of the spectrum is 150kHz and VB of the spectrum is 470kHz (LTE Bandwidth 15MHz).
7. The center frequency of spectrum is the band edge frequency and span is 2MHz. RB of the spectrum is 200kHz and VB of the spectrum is 620kHz (LTE Bandwidth 20MHz).
8. Record the max trace plot into the test report.

3.5.3 TEST SETUP LAYOUT

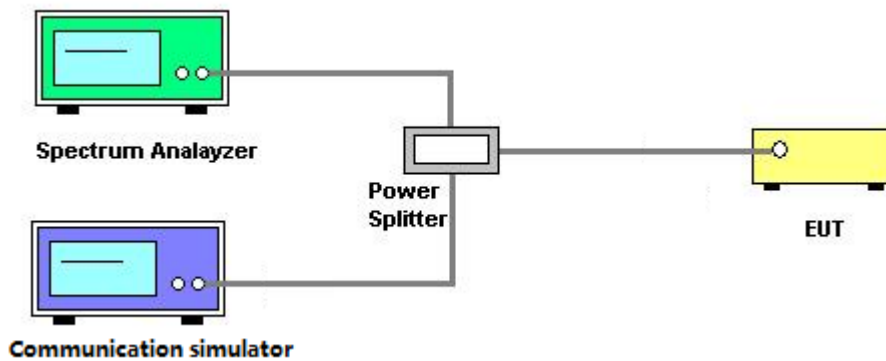

3.5.4 TEST DEVIATION

No deviation

3.5.5 TEST RESULTS

Please refer to the Appendix G.

3.6 PEAK TO AVERAGE RATIO MEASUREMENT

3.6.1 LIMIT

In measuring transmissions in this band using an average power technique, the peak to-average ratio (PAR) of the transmission may not exceed 13 dB.

3.6.2 TEST PROCEDURES

The testing follows FCC KDB 971168 v03r01 Section 5.7.

1. Set resolution/measurement bandwidth \geq signal's occupied bandwidth;
2. Set the number of counts to a value that stabilizes the measured CCDF curve;
3. Record the maximum PAPR level associated with a probability of 0.1%.

3.6.3 TEST SETUP LAYOUT

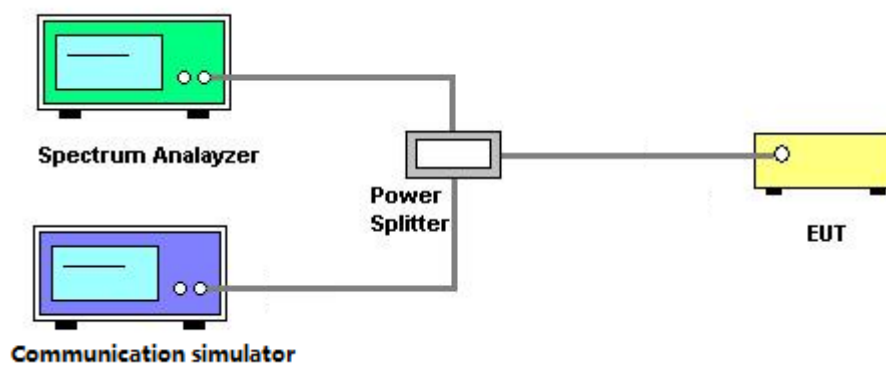

3.6.4 TEST DEVIATION

No deviation

3.6.5 TEST RESULTS

Please refer to the Appendix H.

3.7 FREQUENCY STABILITY MEASUREMENT

3.7.1 LIMIT

± 1.5 ppm is for base and fixed station. ± 2.5 ppm is for mobile station.

3.7.2 TEST PROCEDURES

The testing follows FCC KDB 971168 v03r01 Section 9.

1. Device is placed at the oven room. The oven room could control the temperatures and humidity. Power warm up is at least 15 min and power applied should perform before recording frequency error.
2. EUT is connected the external power supply to control the DC input power. The test voltage range is from minimum to maximum working voltage. Each step shall be record the frequency error rate.
3. The temperature range step is 10 degrees in this test items. All temperature levels shall be hold the $\pm 0.5^{\circ}\text{C}$ during the measurement testing. The each temperature step shall be at least 0.5 hours, consider the EUT could be test under the stability condition.
4. The frequency error was recorded frequency error from the communication simulator.

3.7.3 TEST SETUP LAYOUT

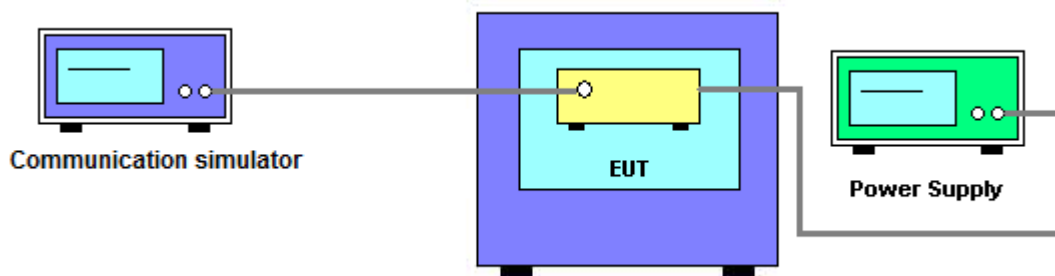

3.7.4 TEST DEVIATION

No deviation

3.7.5 TEST RESULTS

Please refer to the Appendix I.

4. LIST OF MEASUREMENT EQUIPMENTS

Radiated Emission Measurement(30M-1G)					
Item	Kind of Equipment	Manufacturer	Type No.	Serial No.	Calibrated until
1	TRILOG Broadband Antenna	Schwarzbeck	VULB 9168	719	Apr. 02, 2021
2	Pre-Amplifier	emci	EMC9135	980400	Mar. 21, 2021
3	MXE EMI Receiver	Keysight	N9038A	MY56400088	Mar. 21, 2021
4	Test Cable	emci	EMC104-SM-SM-7000	170330	Apr. 13, 2021
5	Test Cable	emci	EMC104-SM-SM-1000	170331	Apr. 13, 2021
6	Test Cable	emci	EMC104-SM-NM-3500	170621	Apr. 13, 2021
7	Measurement Software	Farad	EZ-EMC Ver.NB-03A1-01	N/A	Apr. 13, 2021
8	Wideband Radio Communication Test	R&S	CMW500	129246	Sep. 01, 2020

Radiated Emission Measurement(1G-18G)					
Item	Kind of Equipment	Manufacturer	Type No.	Serial No.	Calibrated until
1	Double-Ridged Waveguide Horn Antenna	ETS-Lindgren	9120D	00206960	Apr. 02, 2021
2	Pre-Amplifier	emci	EMC012645SE	980421	May. 11, 2021
3	EXA Spectrum Analyzer	Keysight	N9010A	MY56480545	Mar. 21, 2021
4	Test Cable	emci	EMC104-SM-SM-7000	170330	Apr. 13, 2021
5	Test Cable	emci	EMC104-SM-SM-1000	170331	Apr. 13, 2021
6	Test Cable	emci	EMC104-SM-NM-3500	170621	Apr. 13, 2021
7	Measurement Software	Farad	EZ-EMC Ver.NB-03A1-01	N/A	N/A
8	Wideband Radio Communication Test	R&S	CMW500	129246	Sep. 01, 2020

Conducted Emission & Band Edge & Occupied Bandwidth Measurement

Item	Kind of Equipment	Manufacturer	Type No.	Serial No.	Calibrated until
1	8960 SERIES 10 WIRELESS COMMUNICATIONS TEST SET	Agilent	E5515C	GB45070942	Sep. 01, 2020
2	Spectrum Analyzer	R&S	FSP40	100626	May. 06, 2021
3	EXA Spectrum Analyzer	Keysight	N9010A	MY56480579	Mar. 21, 2021
4	Power Divider	JUK	PD-2SF-2060	N/A	N/A

Frequency Stability Measurement

Item	Kind of Equipment	Manufacturer	Type No.	Serial No.	Calibrated until
1	8960 SERIES 10 WIRELESS COMMUNICATIONS TEST SET	Agilent	E5515C	GB45070942	Sep. 01, 2020
2*	Spectrum Analyzer	R&S	FSP40	100626	May. 06, 2021
3	EXA Spectrum Analyzer	Keysight	N9010A	MY56480579	Mar. 21, 2021
4	Power Divider	JUK	PD-2SF-2060	N/A	N/A
5	Temperature And Humidity Box	Blue pand	BPHS-120B	170616454	Sep. 01, 2020

Remark: "N/A" denotes no model name, serial no. or calibration specified.

All calibration period of equipment list is one year.

APPENDIX A - OUTPUT POWER

Output Power (dBm):

Modulation	Band	WCDMA Band II		
	Tx Channel	9262CH	9400CH	9538CH
	Frequency	1852.4MHz	1880MHz	1907.6MHz
QPSK	RMC 12.2K	22.52	22.79	22.58
	RMC 64K	22.58	22.49	22.52
	RMC 144K	22.54	22.53	22.55
	RMC 384K	22.68	22.57	22.56

LTE Band / BW	Modulation	RB Size	RB Offset	Low CH	Mid CH	High CH
				18607CH	18900CH	19193CH
				1850.7MHz	1880MHz	1909.3MHz
2 / 1.4M	QPSK	1	0	23.10	23.13	23.59
		1	2	23.49	23.20	23.18
		1	5	23.14	23.16	23.19
		3	0	23.11	23.06	23.26
		3	1	23.20	23.11	23.35
		3	2	23.21	23.15	23.26
	16QAM	6	0	22.00	22.32	22.16
		1	0	22.12	22.44	21.80
		1	2	22.53	22.59	21.73
		1	5	22.23	22.51	21.71
		3	0	22.28	22.44	22.26
		3	1	22.40	22.37	22.20
		3	2	22.29	22.10	22.16
		6	0	21.31	21.51	20.92

LTE Band / BW	Modulation	RB Size	RB Offset	Low CH	Mid CH	High CH
				18615CH	18900CH	19185CH
				1851.5MHz	1880MHz	1908.5MHz
2 / 3M	QPSK	1	0	23.30	23.29	23.19
		1	7	23.44	23.32	23.34
		1	14	23.40	23.29	23.19
		8	0	22.25	22.29	22.19
		8	4	22.16	22.28	22.16
		8	7	22.15	22.27	22.02
		15	0	22.17	22.29	22.25
	16QAM	1	0	22.03	22.67	22.30
		1	7	22.32	22.68	22.42
		1	14	22.12	22.39	22.19
		8	0	21.24	21.47	21.50
		8	4	21.25	21.55	21.19
		8	7	21.06	21.33	21.01
		15	0	21.22	21.34	21.31

LTE Band / BW	Modulation	RB Size	RB Offset	Low CH	Mid CH	High CH
				18625CH	18900CH	19175CH
				1852.5MHz	1880MHz	1907.5MHz
2 / 5M	QPSK	1	0	23.22	23.13	21.73
		1	13	23.29	23.20	22.00
		1	24	23.18	23.12	22.08
		12	0	22.23	22.25	21.17
		12	6	22.32	22.30	21.20
		12	11	22.26	22.22	21.16
		25	0	22.23	22.24	21.16
	16QAM	1	0	21.75	21.80	21.73
		1	13	21.82	21.85	22.00
		1	24	21.86	21.82	22.08
		12	0	21.19	21.20	21.17
		12	6	21.31	21.33	21.20
		12	11	21.43	21.26	21.16
		25	0	21.25	21.29	21.16

LTE Band / BW	Modulation	RB Size	RB Offset	Low CH	Mid CH	High CH
				18650CH	18900CH	19150CH
				1855MHz	1880MHz	1905MHz
2 / 10M	QPSK	1	0	23.52	23.33	23.35
		1	25	23.65	23.44	23.33
		1	49	23.25	23.37	22.92
		25	0	22.31	22.35	22.17
		25	13	22.30	22.28	22.30
		25	25	22.16	22.23	22.27
		50	0	22.21	22.19	22.19
	16QAM	1	0	22.43	22.69	22.17
		1	25	22.80	22.78	22.54
		1	49	22.34	22.67	22.19
		25	0	21.28	21.33	21.39
		25	13	21.20	21.44	21.60
		25	25	21.16	21.18	21.61
		50	0	21.05	21.26	21.26

LTE Band / BW	Modulation	RB Size	RB Offset	Low CH	Mid CH	High CH
				18675CH	18900CH	19125CH
				1857.5MHz	1880MHz	1902.5MHz
2 / 15M	QPSK	1	0	23.65	23.19	23.16
		1	38	23.27	23.22	23.16
		1	74	23.29	23.10	22.99
		36	0	22.20	21.99	22.02
		36	18	22.03	22.20	22.30
		36	39	22.01	22.06	22.26
		75	0	22.16	22.01	22.16
	16QAM	1	0	22.19	21.59	22.21
		1	38	22.68	22.12	22.55
		1	74	22.49	22.26	22.47
		36	0	21.10	21.27	20.96
		36	18	21.05	21.34	21.21
		36	39	20.96	21.13	21.15
		75	0	21.07	21.11	21.09

LTE Band / BW	Modulation	RB Size	RB Offset	Low CH	Mid CH	High CH
				18700CH	18900CH	19100CH
				1860MHz	1880MHz	1900MHz
2 / 20M	QPSK	1	0	23.04	23.10	22.98
		1	50	23.17	23.30	23.13
		1	99	23.01	22.96	22.88
		50	0	22.17	22.08	22.04
		50	25	22.15	22.27	22.14
		50	50	21.98	22.03	22.11
		100	0	22.07	21.98	22.07
	16QAM	1	0	21.64	21.75	21.64
		1	50	22.88	22.48	22.60
		1	99	21.80	21.76	21.99
		50	0	21.17	21.10	21.18
		50	25	21.15	21.30	21.30
		50	50	21.11	21.21	21.25
		100	0	21.28	21.20	21.21

LTE Band / BW	Modulation	RB Size	RB Offset	Low CH	Mid CH	High CH
				26047CH	26365CH	26683CH
				1850.7MHz	1882.5MHz	1914.3MHz
25 / 1.4M	QPSK	1	0	23.28	23.21	23.12
		1	2	23.37	23.31	23.36
		1	5	23.34	23.25	23.17
		3	0	23.26	23.16	23.23
		3	1	23.36	23.31	23.31
		3	2	23.24	23.29	23.13
	16QAM	6	0	22.19	22.29	22.33
		1	0	21.99	22.02	22.28
		1	2	22.31	22.06	22.34
		1	5	21.95	21.75	22.30
		3	0	22.26	22.19	22.53
		3	1	22.12	22.25	22.45
		3	2	22.11	22.16	22.25
		6	0	21.02	21.10	21.27

LTE Band / BW	Modulation	RB Size	RB Offset	Low CH	Mid CH	High CH
				26055CH	26365CH	26675CH
				1851.5MHz	1882.5MHz	1913.5MHz
25 / 3M	QPSK	1	0	23.25	23.17	23.28
		1	7	23.34	23.31	23.35
		1	14	23.30	23.15	23.32
		8	0	22.26	22.31	22.41
		8	4	22.34	22.38	22.35
		8	7	22.33	22.39	22.37
		15	0	22.38	22.26	22.39
	16QAM	1	0	22.37	22.55	22.31
		1	7	22.45	22.52	22.34
		1	14	22.25	22.34	22.45
		8	0	20.92	21.10	21.16
		8	4	20.87	21.14	21.07
		8	7	20.95	21.19	21.36
		15	0	21.24	21.33	21.46

LTE Band / BW	Modulation	RB Size	RB Offset	Low CH	Mid CH	High CH
				26065CH	26365CH	26665CH
				1852.5MHz	1882.5MHz	1912.5MHz
25 / 5M	QPSK	1	0	23.13	22.89	22.99
		1	13	23.33	22.96	23.16
		1	24	23.39	22.96	23.26
		12	0	22.26	22.30	22.34
		12	6	22.28	22.42	22.37
		12	11	22.42	22.39	22.29
	16QAM	25	0	22.26	22.31	22.31
		1	0	21.60	21.98	21.90
		1	13	21.67	22.15	21.92
		1	24	21.83	21.90	21.81
		12	0	21.32	21.32	21.29
		12	6	21.34	21.23	21.24
		12	11	21.48	21.25	21.24
		25	0	21.45	21.37	21.39

LTE Band / BW	Modulation	RB Size	RB Offset	Low CH	Mid CH	High CH
				26090CH	26365CH	26640CH
				1855MHz	1882.5MHz	1910MHz
25 / 10M	QPSK	1	0	23.49	23.15	23.14
		1	25	23.78	23.59	23.40
		1	49	23.44	23.39	23.43
		25	0	22.37	22.30	22.37
		25	13	22.35	22.40	22.17
		25	25	22.24	22.36	22.33
	16QAM	50	0	22.29	22.29	22.31
		1	0	22.40	21.48	22.04
		1	25	22.47	22.51	22.18
		1	49	22.51	22.08	22.44
		25	0	21.31	21.30	21.52
		25	13	21.39	21.64	21.36
		25	25	21.29	21.58	21.58
		50	0	21.39	21.29	21.40

LTE Band / BW	Modulation	RB Size	RB Offset	Low CH	Mid CH	High CH
				26115CH	26365CH	26615CH
				1857.5MHz	1882.5MHz	1907.5MHz
25 / 15M	QPSK	1	0	23.01	23.02	23.12
		1	38	23.80	23.16	23.14
		1	74	23.54	23.06	23.16
		36	0	22.40	22.24	22.27
		36	18	22.31	22.39	22.38
		36	39	22.29	22.39	22.11
		75	0	22.31	22.25	22.18
	16QAM	1	0	22.36	21.47	22.95
		1	38	22.97	22.08	23.21
		1	74	22.37	22.61	23.03
		36	0	21.41	21.35	21.17
		36	18	21.34	21.45	21.31
		36	39	21.35	21.43	21.18
		75	0	21.27	21.34	21.29

LTE Band / BW	Modulation	RB Size	RB Offset	Low CH	Mid CH	High CH
				26140CH	26365CH	26590CH
				1860MHz	1882.5MHz	1905MHz
25 / 20M	QPSK	1	0	22.60	23.18	22.89
		1	50	23.20	23.45	23.10
		1	99	22.85	23.08	22.99
		50	0	22.28	22.21	22.11
		50	25	22.40	22.28	22.25
		50	50	22.34	22.18	22.11
		100	0	22.32	22.23	22.17
	16QAM	1	0	21.64	22.13	21.54
		1	50	22.05	22.41	22.76
		1	99	21.70	21.74	22.23
		50	0	21.47	21.16	21.02
		50	25	21.47	21.23	21.23
		50	50	21.30	21.28	21.15
		100	0	21.30	21.33	21.18

EIRP Power (dBm):

Modulation	Band	WCDMA Band II		
	Tx Channel	9262CH	9400CH	9538CH
	Frequency	1852.4MHz	1880MHz	1907.6MHz
QPSK	RMC 12.2K	24.11	24.38	24.17
	RMC 64K	24.17	24.08	24.11
	RMC 144K	24.13	24.12	24.14
	RMC 384K	24.27	24.16	24.15

LTE Band / BW	Modulation	RB Size	RB Offset	Low CH	Mid CH	High CH
				18607CH	18900CH	19193CH
				1850.7MHz	1880MHz	1909.3MHz
2 / 1.4M	QPSK	1	0	24.69	24.72	25.18
		1	2	25.08	24.79	24.77
		1	5	24.73	24.75	24.78
		3	0	24.70	24.65	24.85
		3	1	24.79	24.70	24.94
		3	2	24.80	24.74	24.85
	16QAM	6	0	23.59	23.91	23.75
		1	0	23.71	24.03	23.39
		1	2	24.12	24.18	23.32
		1	5	23.82	24.10	23.30
		3	0	23.87	24.03	23.85
		3	1	23.99	23.96	23.79
		3	2	23.88	23.69	23.75
		6	0	22.90	23.10	22.51

LTE Band / BW	Modulation	RB Size	RB Offset	Low CH	Mid CH	High CH
				18615CH	18900CH	19185CH
				1851.5MHz	1880MHz	1908.5MHz
2 / 3M	QPSK	1	0	24.89	24.88	24.78
		1	7	25.03	24.91	24.93
		1	14	24.99	24.88	24.78
		8	0	23.84	23.88	23.78
		8	4	23.75	23.87	23.75
		8	7	23.74	23.86	23.61
		15	0	23.76	23.88	23.84
	16QAM	1	0	23.62	24.26	23.89
		1	7	23.91	24.27	24.01
		1	14	23.71	23.98	23.78
		8	0	22.83	23.06	23.09
		8	4	22.84	23.14	22.78
		8	7	22.65	22.92	22.60
		15	0	22.81	22.93	22.90

LTE Band / BW	Modulation	RB Size	RB Offset	Low CH	Mid CH	High CH
				18625CH	18900CH	19175CH
				1852.5MHz	1880MHz	1907.5MHz
2 / 5M	QPSK	1	0	24.81	24.72	23.32
		1	13	24.88	24.79	23.59
		1	24	24.77	24.71	23.67
		12	0	23.82	23.84	22.76
		12	6	23.91	23.89	22.79
		12	11	23.85	23.81	22.75
	16QAM	25	0	23.82	23.83	22.75
		1	0	23.34	23.39	23.32
		1	13	23.41	23.44	23.59
		1	24	23.45	23.41	23.67
		12	0	22.78	22.79	22.76
		12	6	22.90	22.92	22.79
		12	11	23.02	22.85	22.75
		25	0	22.84	22.88	22.75

LTE Band / BW	Modulation	RB Size	RB Offset	Low CH	Mid CH	High CH
				18650CH	18900CH	19150CH
				1855MHz	1880MHz	1905MHz
2 / 10M	QPSK	1	0	25.11	24.92	24.94
		1	25	25.24	25.03	24.92
		1	49	24.84	24.96	24.51
		25	0	23.90	23.94	23.76
		25	13	23.89	23.87	23.89
		25	25	23.75	23.82	23.86
	16QAM	50	0	23.80	23.78	23.78
		1	0	24.02	24.28	23.76
		1	25	24.39	24.37	24.13
		1	49	23.93	24.26	23.78
		25	0	22.87	22.92	22.98
		25	13	22.79	23.03	23.19
		25	25	22.75	22.77	23.20
		50	0	22.64	22.85	22.85

LTE Band / BW	Modulation	RB Size	RB Offset	Low CH	Mid CH	High CH
				18675CH	18900CH	19125CH
				1857.5MHz	1880MHz	1902.5MHz
2 / 15M	QPSK	1	0	25.24	24.78	24.75
		1	38	24.86	24.81	24.75
		1	74	24.88	24.69	24.58
		36	0	23.79	23.58	23.61
		36	18	23.62	23.79	23.89
		36	39	23.60	23.65	23.85
		75	0	23.75	23.60	23.75
	16QAM	1	0	23.78	23.18	23.80
		1	38	24.27	23.71	24.14
		1	74	24.08	23.85	24.06
		36	0	22.69	22.86	22.55
		36	18	22.64	22.93	22.80
		36	39	22.55	22.72	22.74
		75	0	22.66	22.70	22.68

LTE Band / BW	Modulation	RB Size	RB Offset	Low CH	Mid CH	High CH
				18700CH	18900CH	19100CH
				1860MHz	1880MHz	1900MHz
2 / 20M	QPSK	1	0	24.63	24.69	24.57
		1	50	24.76	24.89	24.72
		1	99	24.60	24.55	24.47
		50	0	23.76	23.67	23.63
		50	25	23.74	23.86	23.73
		50	50	23.57	23.62	23.70
		100	0	23.66	23.57	23.66
	16QAM	1	0	23.23	23.34	23.23
		1	50	24.47	24.07	24.19
		1	99	23.39	23.35	23.58
		50	0	22.76	22.69	22.77
		50	25	22.74	22.89	22.89
		50	50	22.70	22.80	22.84
		100	0	22.87	22.79	22.80

LTE Band / BW	Modulation	RB Size	RB Offset	Low CH	Mid CH	High CH
				26047CH	26365CH	26683CH
				1850.7MHz	1882.5MHz	1914.3MHz
25 / 1.4M	QPSK	1	0	24.87	24.80	24.71
		1	2	24.96	24.90	24.95
		1	5	24.93	24.84	24.76
		3	0	24.85	24.75	24.82
		3	1	24.95	24.90	24.90
		3	2	24.83	24.88	24.72
	16QAM	6	0	23.78	23.88	23.92
		1	0	23.58	23.61	23.87
		1	2	23.90	23.65	23.93
		1	5	23.54	23.34	23.89
		3	0	23.85	23.78	24.12
		3	1	23.71	23.84	24.04
		3	2	23.70	23.75	23.84
		6	0	22.61	22.69	22.86

LTE Band / BW	Modulation	RB Size	RB Offset	Low CH	Mid CH	High CH
				26055CH	26365CH	26675CH
				1851.5MHz	1882.5MHz	1913.5MHz
25 / 3M	QPSK	1	0	24.84	24.76	24.87
		1	7	24.93	24.90	24.94
		1	14	24.89	24.74	24.91
		8	0	23.85	23.90	24.00
		8	4	23.93	23.97	23.94
		8	7	23.92	23.98	23.96
		15	0	23.97	23.85	23.98
	16QAM	1	0	23.96	24.14	23.90
		1	7	24.04	24.11	23.93
		1	14	23.84	23.93	24.04
		8	0	22.51	22.69	22.75
		8	4	22.46	22.73	22.66
		8	7	22.54	22.78	22.95
		15	0	22.83	22.92	23.05

LTE Band / BW	Modulation	RB Size	RB Offset	Low CH	Mid CH	High CH
				26065CH	26365CH	26665CH
				1852.5MHz	1882.5MHz	1912.5MHz
25 / 5M	QPSK	1	0	24.72	24.48	24.58
		1	13	24.92	24.55	24.75
		1	24	24.98	24.55	24.85
		12	0	23.85	23.89	23.93
		12	6	23.87	24.01	23.96
		12	11	24.01	23.98	23.88
		25	0	23.85	23.90	23.90
	16QAM	1	0	23.19	23.57	23.49
		1	13	23.26	23.74	23.51
		1	24	23.42	23.49	23.40
		12	0	22.91	22.91	22.88
		12	6	22.93	22.82	22.83
		12	11	23.07	22.84	22.83
		25	0	23.04	22.96	22.98

LTE Band / BW	Modulation	RB Size	RB Offset	Low CH	Mid CH	High CH
				26090CH	26365CH	26640CH
				1855MHz	1882.5MHz	1910.0MHz
25 / 10M	QPSK	1	0	25.08	24.74	24.73
		1	25	25.37	25.18	24.99
		1	49	25.03	24.98	25.02
		25	0	23.96	23.89	23.96
		25	13	23.94	23.99	23.76
		25	25	23.83	23.95	23.92
		50	0	23.88	23.88	23.90
	16QAM	1	0	23.99	23.07	23.63
		1	25	24.06	24.10	23.77
		1	49	24.10	23.67	24.03
		25	0	22.90	22.89	23.11
		25	13	22.98	23.23	22.95
		25	25	22.88	23.17	23.17
		50	0	22.98	22.88	22.99

LTE Band / BW	Modulation	RB Size	RB Offset	Low CH	Mid CH	High CH
				26115CH	26365CH	26615CH
				1857.5MHz	1882.5MHz	1907.5MHz
25 / 15M	QPSK	1	0	24.60	24.61	24.71
		1	38	25.39	24.75	24.73
		1	74	25.13	24.65	24.75
		36	0	23.99	23.83	23.86
		36	18	23.90	23.98	23.97
		36	39	23.88	23.98	23.70
		75	0	23.90	23.84	23.77
	16QAM	1	0	23.95	23.06	24.54
		1	38	24.56	23.67	24.80
		1	74	23.96	24.20	24.62
		36	0	23.00	22.94	22.76
		36	18	22.93	23.04	22.90
		36	39	22.94	23.02	22.77
		75	0	22.86	22.93	22.88

LTE Band / BW	Modulation	RB Size	RB Offset	Low CH	Mid CH	High CH
				26140CH	26365CH	26590CH
				1860MHz	1882.5MHz	1905MHz
25 / 20M	QPSK	1	0	24.19	24.77	24.48
		1	50	24.79	25.04	24.69
		1	99	24.44	24.67	24.58
		50	0	23.87	23.80	23.70
		50	25	23.99	23.87	23.84
		50	50	23.93	23.77	23.70
		100	0	23.91	23.82	23.76
	16QAM	1	0	23.23	23.72	23.13
		1	50	23.64	24.00	24.35
		1	99	23.29	23.33	23.82
		50	0	23.06	22.75	22.61
		50	25	23.06	22.82	22.82
		50	50	22.89	22.87	22.74
		100	0	22.89	22.92	22.77

APPENDIX B - OCCUPIED BANDWIDTH

WCDMA Band II

QPSK

Channel	Frequency (MHz)	99% Occupied Bandwidth (MHz)	Channel	Frequency (MHz)	26dB Bandwidth (MHz)
9262	1852.4	4.1307	9262	1852.4	4.711
9400	1880	4.1327	9400	1880	4.698
9538	1907.6	4.1471	9538	1907.6	4.701

Spectrum Plot



LTE Band 2_1.4M					
QPSK			16QAM		
Channel	Frequency (MHz)	99% Occupied Bandwidth (MHz)	Channel	Frequency (MHz)	99% Occupied Bandwidth (MHz)
18607	1850.7	1.1017	18607	1850.7	1.0898
18900	1880	1.0874	18900	1880	1.0937
19193	1909.3	1.0916	19193	1909.3	1.0893
Channel	Frequency (MHz)	26dB Bandwidth (MHz)	Channel	Frequency (MHz)	26dB Bandwidth (MHz)
18607	1850.7	1.3170	18607	1850.7	1.2650
18900	1880	1.2860	18900	1880	1.2820
19193	1909.3	1.3370	19193	1909.3	1.3120

Spectrum Plot

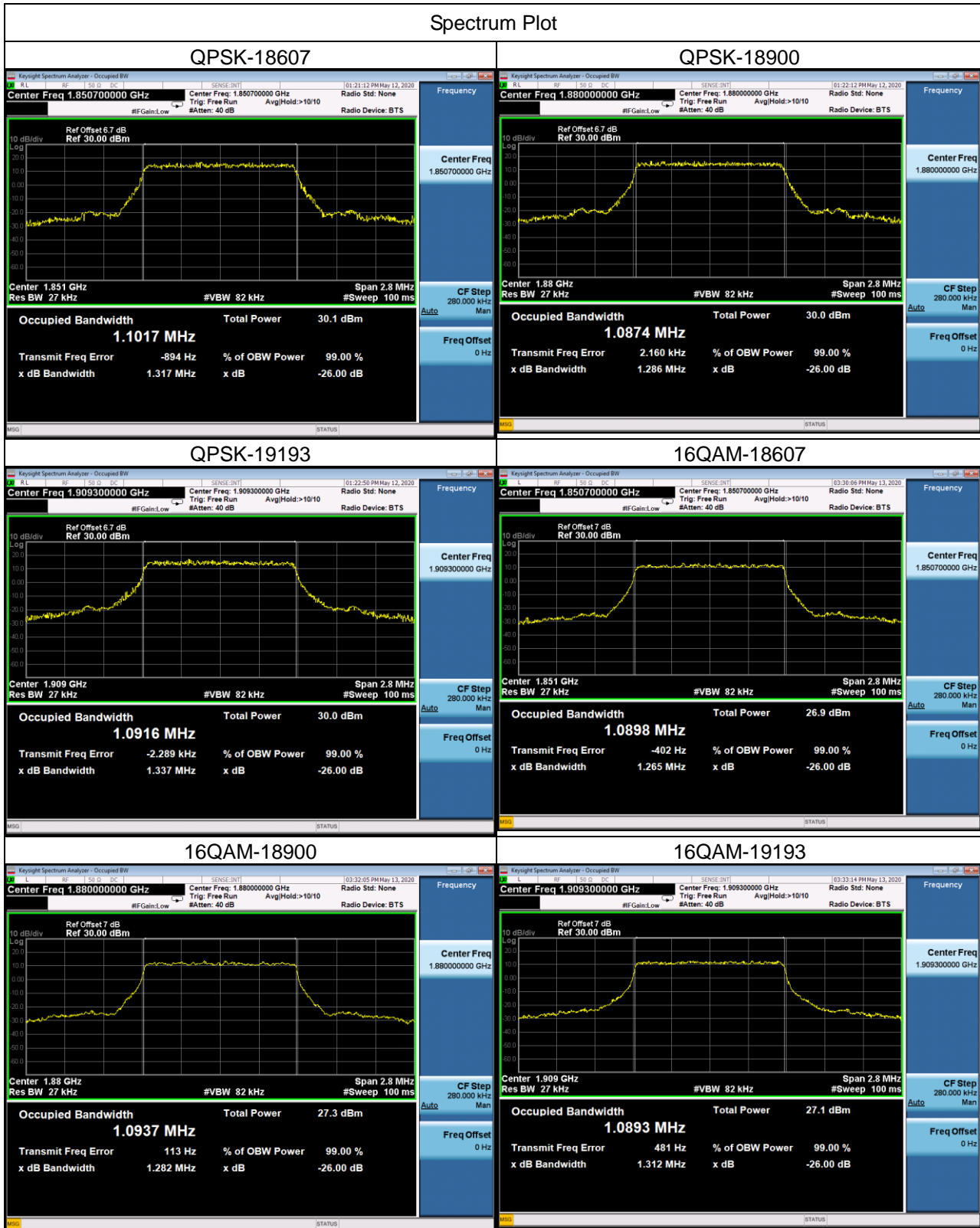

LTE Band 2_3M					
QPSK			16QAM		
Channel	Frequency (MHz)	99% Occupied Bandwidth (MHz)	Channel	Frequency (MHz)	99% Occupied Bandwidth (MHz)
18615	1851.5	2.6972	18615	1851.5	2.7032
18900	1880	2.7032	18900	1880	2.7040
19185	1908.5	2.6975	19185	1908.5	2.7077
Channel	Frequency (MHz)	26dB Bandwidth (MHz)	Channel	Frequency (MHz)	26dB Bandwidth (MHz)
18615	1851.5	2.9770	18615	1851.5	2.9400
18900	1880	2.9840	18900	1880	2.9550
19185	1908.5	2.9800	19185	1908.5	2.9770

Spectrum Plot

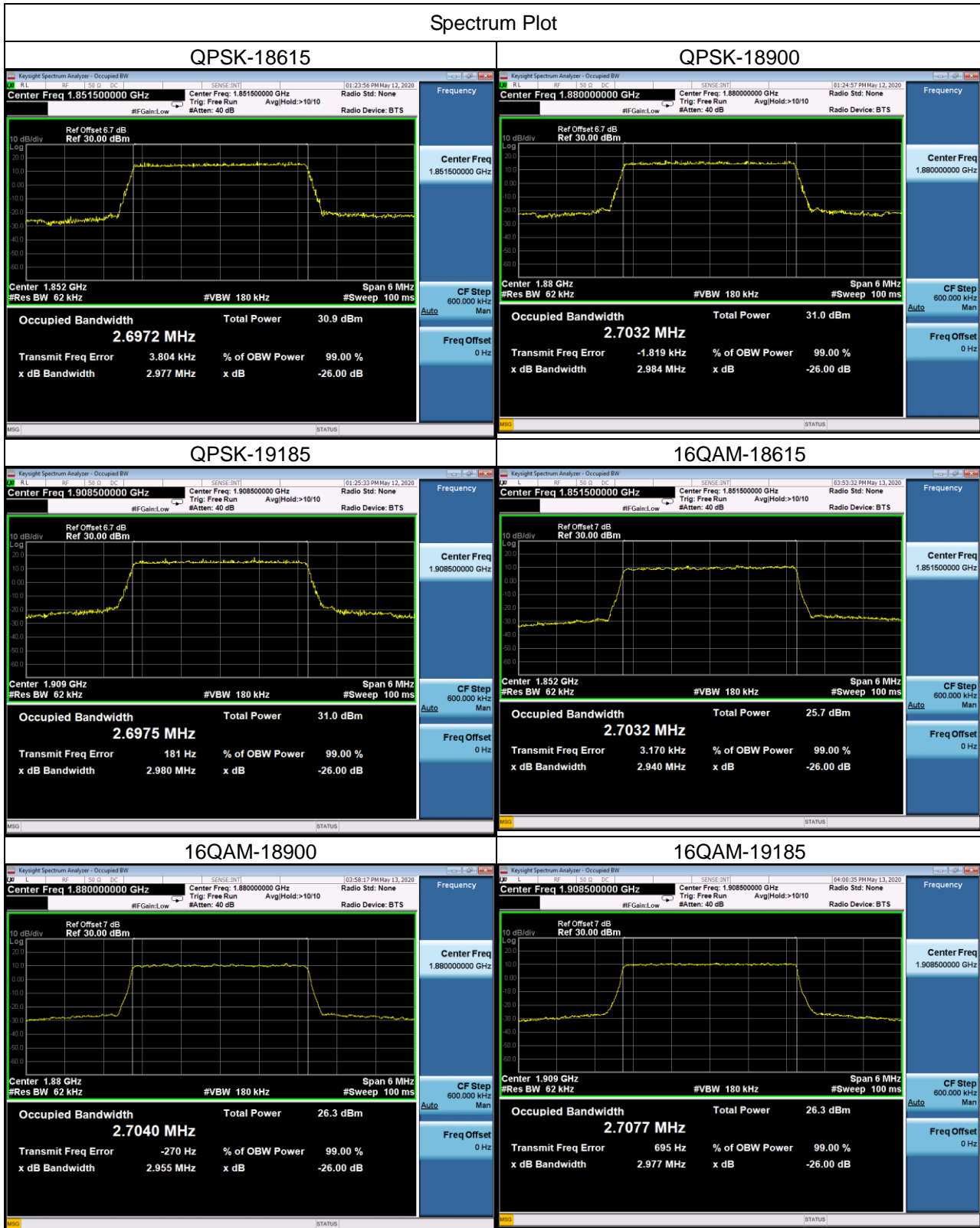

LTE Band 2_5M					
QPSK			16QAM		
Channel	Frequency (MHz)	99% Occupied Bandwidth (MHz)	Channel	Frequency (MHz)	99% Occupied Bandwidth (MHz)
18625	1852.5	4.5139	18625	1852.5	4.5034
18900	1880	4.5121	18900	1880	4.4975
19175	1907.5	4.5025	19175	1907.5	4.4982
Channel	Frequency (MHz)	26dB Bandwidth (MHz)	Channel	Frequency (MHz)	26dB Bandwidth (MHz)
18625	1852.5	5.0210	18625	1852.5	4.8680
18900	1880	4.9770	18900	1880	4.8920
19175	1907.5	4.9770	19175	1907.5	4.8530

Spectrum Plot

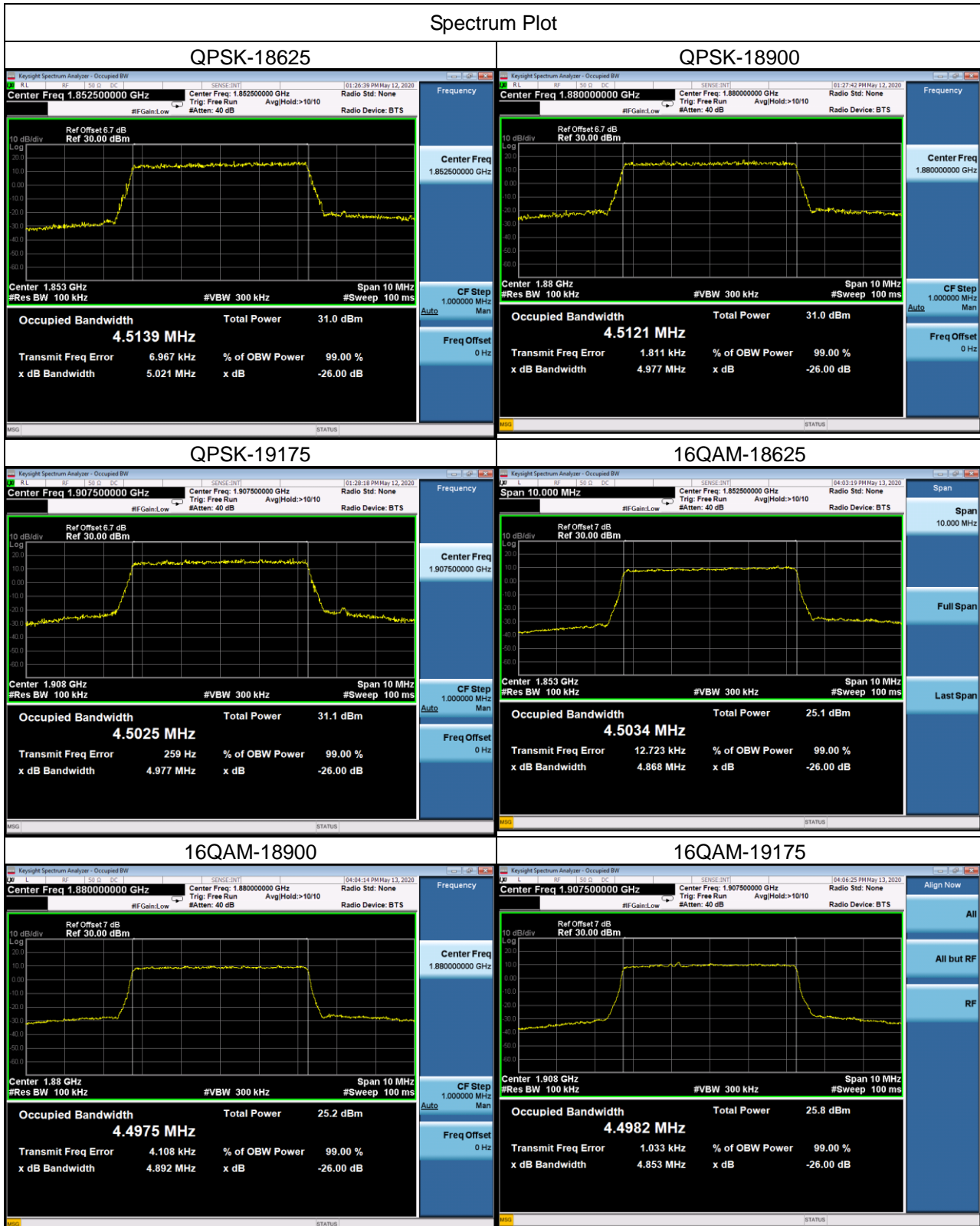

LTE Band 2_10M					
QPSK			16QAM		
Channel	Frequency (MHz)	99% Occupied Bandwidth (MHz)	Channel	Frequency (MHz)	99% Occupied Bandwidth (MHz)
18650	1855	8.9250	18650	1855	8.9132
18900	1880	8.9507	18900	1880	8.9733
19150	1905	8.9702	19150	1905	8.9590
Channel	Frequency (MHz)	26dB Bandwidth (MHz)	Channel	Frequency (MHz)	26dB Bandwidth (MHz)
18650	1855	9.9890	18650	1855	9.5490
18900	1880	9.9220	18900	1880	9.6500
19150	1905	9.8970	19150	1905	9.5470

Spectrum Plot

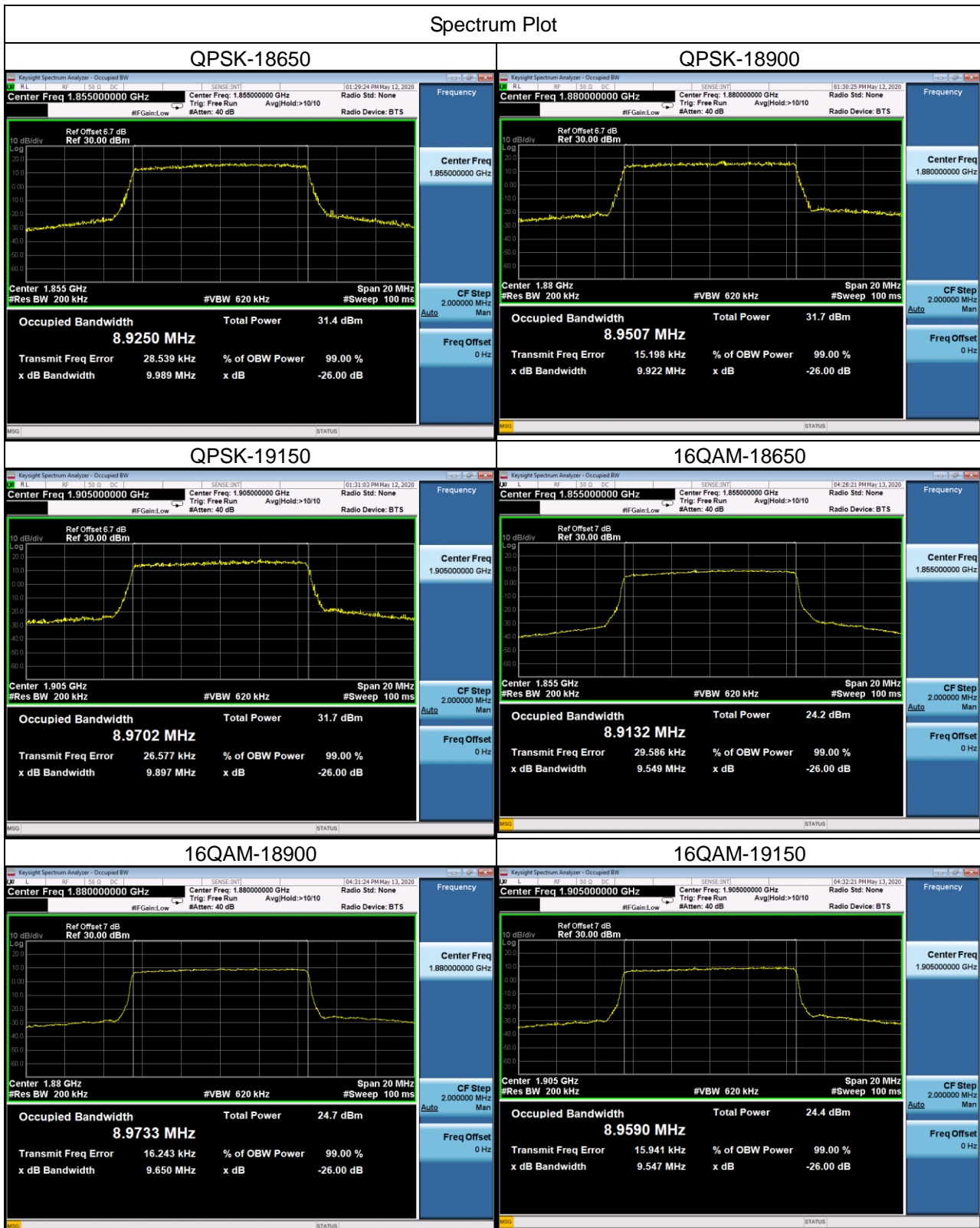

LTE Band 2_15M					
QPSK			16QAM		
Channel	Frequency (MHz)	99% Occupied Bandwidth (MHz)	Channel	Frequency (MHz)	99% Occupied Bandwidth (MHz)
18675	1857.5	13.3110	18675	1857.5	13.3680
18900	1880	13.4320	18900	1880	13.4370
19125	1902.5	13.4620	19125	1902.5	13.4770
Channel	Frequency (MHz)	26dB Bandwidth (MHz)	Channel	Frequency (MHz)	26dB Bandwidth (MHz)
18675	1857.5	14.6100	18675	1857.5	14.2200
18900	1880	14.7600	18900	1880	14.2300
19125	1902.5	14.7100	19125	1902.5	14.2700