

FCC Radio Test Report

FCC ID: XMR202005SC200RNA

This report concerns: Original Grant

Project No. : 2005H018
Equipment : Multi-mode Smart LTE Module
Brand Name : Quectel
Test Model : SC200R-NA
Series Model : N/A
Applicant : Quectel Wireless Solutions Co., Ltd.
Address : Building 5, Shanghai Business Park Phase III (Area B), No.1016 Tianlin Road, Minhang District, Shanghai, China 200233.
Manufacturer : Quectel Wireless Solutions Co., Ltd.
Address : Building 5, Shanghai Business Park Phase III (Area B), No.1016 Tianlin Road, Minhang District, Shanghai, China 200233.
Date of Receipt : May 08, 2020
Date of Test : May 08, 2020 ~ Jun. 05, 2020
Issued Date : Aug. 10, 2020
Report Version : R00
Test Sample : Engineering Sample No.: SH2020050840, SH2020050840-1
Standard(s) : 47 CFR FCC Part 90 Subpart R
47 CFR FCC Part 2
ANSI/TIA-603-D-2010
FCC KDB 971168 D01 Power Meas License Digital Systems v03

The above equipment has been tested and found compliance with the requirement of the relative standards by BTL Inc.

Krain. Wu

Prepared by : Krain Wu

Ryan. Wang

Approved by : Ryan Wang



Certificate # 5123. 03

Add: No. 29, Jintang Road, Tangzhen Industry Park, Pudong New Area, Shanghai 201210, China

TEL: +86-021-61765666

Web: www.newbtl.com

Declaration

BTL represents to the client that testing is done in accordance with standard procedures as applicable and that test instruments used has been calibrated with standards traceable to international standard(s) and/or national standard(s).

BTL's reports apply only to the specific samples tested under conditions. It is manufacture's responsibility to ensure that additional production units of this model are manufactured with the identical electrical and mechanical components. **BTL** shall have no liability for any declarations, inferences or generalizations drawn by the client or others from **BTL** issued reports.

The report must not be used by the client to claim product certification, approval, or endorsement by NIST, A2LA, or any agency of the U.S. Government.

This report is the confidential property of the client. As a mutual protection to the clients, the public and ourselves, the test report shall not be reproduced, except in full, without our written approval.

BTL's laboratory quality assurance procedures are in compliance with the **ISO/IEC 17025** requirements, and accredited by the conformity assessment authorities listed in this test report.

BTL is not responsible for the sampling stage, so the results only apply to the sample as received.

The information, data and test plan are provided by manufacturer which may affect the validity of results, so it is manufacturer's responsibility to ensure that the apparatus meets the essential requirements of applied standards and in all the possible configurations as representative of its intended use.

Limitation

For the use of the authority's logo is limited unless the Test Standard(s)/Scope(s)/Item(s) mentioned in this test report is (are) included in the conformity assessment authorities acceptance respective.

Please note that the measurement uncertainty is provided for informational purpose only and is not use in determining the Pass/Fail results.

Table of Contents	Page
REPORT ISSUED HISTORY	5
1 . SUMMARY OF TEST RESULTS	6
1.1 TEST FACILITY	7
1.2 MEASUREMENT UNCERTAINTY	7
1.3 TEST ENVIRONMENT CONDITIONS	7
2 . GENERAL INFORMATION	8
2.1 GENERAL DESCRIPTION OF EUT	8
2.2 DESCRIPTION OF TEST MODES AND TEST CONDITION	9
2.3 BLOCK DIGRAM SHOWING THECONFIGURATIONOFSYSTEMTESTED FOR RADIATED	10
3.4 DESCRIPTION OF SUPPORT UNITS	10
3 . TEST RESULT	11
3.1 OUTPUT POWER MEASUREMENT	11
3.1.1 LIMIT	11
3.1.2 TEST PROCEDURE	11
3.1.3 TESTSETUP LAYOUT	11
3.1.4 TEST DEVIATION	11
3.1.5 TEST RESULTS	11
3.2 OCCUPIED BANDWIDTH MEASUREMENT	12
3.2.1 TEST PROCEDURE	12
3.2.2 TEST SETUP LAYOUT	12
3.2.3 TEST DEVIATION	12
3.2.4 TEST RESULTS	12
3.3 CONDUCTED EMISSIONS MEASUREMENT	13
3.3.1 LIMIT	13
3.3.2 TEST PROCEDURES	13
3.3.3 TESTSETUP LAYOUT	13
3.3.4 TESTDEVIATION	13
3.3.5 TEST RESULTS	13
3.4 RADIATED EMISSIONS MEASUREMENT	14
3.4.1 LIMIT	14
3.4.2 TEST PROCEDURES	14
3.4.3 TESTSETUP LAYOUT	14
3.4.4 TESTDEVIATION	15
3.4.5 TEST RESULTS (9KHZ TO 30MHZ)	15
3.4.6 TEST RESULTS (30MHZ TO 1000MHZ)	15
3.4.7 TEST RESULTS (ABOVE 1000MHZ)	15
3.5 BAND EDGE /EMISSION MASK MEASUREMENT	16
3.5.1 LIMIT	16

Table of Contents	Page
3.5.2 TEST PROCEDURES	16
3.5.3 TESTSETUP LAYOUT	16
3.5.4 TESTDEVIATION	16
3.5.5 TEST RESULTS	16
3.6 PEAK TO AVERAGE RATIO MEASUREMENT	17
3.6.1 LIMIT	17
3.6.2 TEST PROCEDURES	17
3.6.3 TEST SETUP LAYOUT	17
3.6.4 TEST DEVIATION	17
3.6.5 TEST RESULTS	17
3.7 FREQUENCY STABILITY MEASUREMENT	18
3.7.1 LIMIT	18
3.7.2 TEST PROCEDURES	18
3.7.3 TESTSETUP LAYOUT	18
3.7.4 TESTDEVIATION	18
3.7.5 TEST RESULTS	18
4. LIST OF MEASUREMENT EQUIPMENTS	19
APPENDIX A - OUTPUT POWER	21
APPENDIX B - OCCUPIED BANDWIDTH	24
APPENDIX C - CONDUCTED EMISSIONS	28
APPENDIX D - RADIATED SPURIOUS EMISSIONS (9KHZ TO 30MHZ)	31
APPENDIX E - RADIATED EMISSION (30MHZ TO 1GHZ)	32
APPENDIX F - RADIATED EMISSION (ABOVE 1GHZ)	35
APPENDIX G - BAND EDGE	40
APPENDIX H - PEAK TO AVERAGE RATIO	42
APPENDIX I - FREQUENCY STABILITY	45

REPORT ISSUED HISTORY

Report Version	Description	Issued Date
R00	Original Issue.	Aug. 10, 2020

1. SUMMARY OF TEST RESULTS

Test procedures according to the technical standard(s):

FCC Part 90 Subpart R & Part 2			
Standard(s) Section	Test Item	Judgment	Remark
2.1046 & 90.542	Radiated power	PASS	-----
2.1046 & 90.542	Conducted Output Power	PASS	-----
2.1049	Occupied Bandwidth	PASS	-----
2.1051 & 90.543	Conducted Spurious Emissions	PASS	-----
2.1053 & 90.543	Radiated Spurious Emissions	PASS	-----
2.1051 & 90.543	Band Edge Measurements	PASS	-----
2.1055 & 90.539	Frequency Stability	PASS	-----
-	Peak To Average Ratio	PASS	-----

Note:

For the verdict, the "N/A" denotes "not applicable", the "N/T" denotes "not tested".

1.1 TEST FACILITY

The test facilities used to collect the test data in this report is at the location of No. 29, Jintang Road, Tangzhen Industry Park, Pudong New Area, Shanghai 201210,China
 BTL's Test Firm Registration Number for FCC: 476765
 BTL's Designation Number for FCC: CN1241

1.2 MEASUREMENT UNCERTAINTY

The measurement uncertainty figures shall be calculated according the methods described in the ETSI TR 100 028 and shall correspond to an expansion factor (coverage factor) $k=1.96$ or $k=2$ (which provide confidence levels of respectively 90% and 95.45% in the case where the distributions characterizing the actual measurement uncertainties are normal (Gaussian)).
 Measurement Uncertainty for a Level of Confidence of 95 %, $U=2xUc(y)$.

The BTL measurement uncertainty as below table:

A. Radiated Measurement :

Test Site	Method	Measurement Frequency Range	Ant. H / V	U,(dB)
SH-CB01	CISPR	9KHz ~ 30MHz	V	3.79
		9KHz ~ 30MHz	H	3.57
		30MHz ~ 200MHz	V	4.12
		30MHz ~ 200MHz	H	3.20
		200MHz ~ 1,000MHz	V	3.12
		200MHz ~ 1,000MHz	H	3.18

Test Site	Method	Measurement Frequency Range	U,(dB)
SH-CB01	CISPR	1GHz ~ 6GHz	4.40
		6GHz ~ 18GHz	4.86

Test Site	Method	Measurement Frequency Range	U,(dB)
SH-CB01	CISPR	18 ~ 26.5 GHz	3.64
		26.5 ~ 40 GHz	3.78

Note: Unless specifically mentioned, the uncertainty of measurement has not been taken into account to declare the compliance or non-compliance to the specification.

1.3 TEST ENVIRONMENT CONDITIONS

Test Item	Temperature	Humidity	Test Voltage	Tested By
Output Power & ERP	23°C	60%	DC 3.8V	Forest Li
Occupied Bandwidth	23°C	60%	DC 3.8V	Forest Li
Conducted Spurious Emissions	23°C	60%	DC 3.8V	Forest Li
Radiated Spurious Emissions	23°C	46%	DC 3.8V	Forest Li
Band Edge	23°C	60%	DC 3.8V	Forest Li
Peak to Average Ratio	23°C	60%	DC 3.8V	Forest Li
Frequency Stability	Normal and Extreme			Forest Li

2. GENERAL INFORMATION

2.1 GENERAL DESCRIPTION OF EUT

Equipment	Multi-mode Smart LTE Module			
Brand Name	Quectel			
Test Model	SC200R-NA			
Series Model	N/A			
Model Difference(s)	N/A			
Software Version	SC200RNANAR04A01			
Hardware Version	R1.0			
Power Source	DC power supply.			
Power Rating	DC 3.8V			
Antenna Type	Dipole			
Antenna Gain	LTE Band 14	3.63 dBi		
Modulation Type	LTE	UL: QPSK,16QAM DL: QPSK,16QAM		
Operation Frequency	LTE Band 14 (Channel Bandwidth: 5MHz)	790.5MHz ~ 795.5MHz		
	LTE Band 14 (Channel Bandwidth: 10MHz)	793.0MHz		
Max. ERP Power	LTE Band 14 (Channel Bandwidth: 5MHz)	QPSK	25.73	dBm
		16QAM	24.52	dBm
	LTE Band 14 (Channel Bandwidth: 10MHz)	QPSK	25.79	dBm
		16QAM	24.85	dBm

Note:

- For a more detailed features description, please refer to the manufacturer's specifications or the user's manual.

2.2 DESCRIPTION OF TEST MODES AND TEST CONDITION

Following channel(s) was (were) selected for the final test as listed below:

LTE BAND 14 MODE					
Test Item	Available Channel	Tested Channel	Channel Bandwidth	Modulation	Mode
Output Power & ERP	23330 to 23355	23330 to 23355	5MHz	QPSK, 16QAM	1RB/12RB/25RB
		23330	10MHz	QPSK, 16QAM	1RB/25RB/50RB
Occupied Bandwidth	23330 to 23355	23230	5MHz	QPSK, 16QAM	25RB
	23330 to 23355	23330	10MHz	QPSK, 16QAM	50RB
Conducted Spurious Emission	23330 to 23355	23230	5MHz	QPSK	1 RB
		23330	10MHz	QPSK	1 RB
Radiated Spurious Emission	23330 to 23355	23230	5MHz	QPSK	1 RB
	23330 to 23355	23330	10MHz	QPSK	1 RB
Band Edge	23330 to 23355	23330 to 23355	5MHz	QPSK	1RB/25RB
	23330 to 23355	23230	10MHz	QPSK	1RB/50RB
Peak To Average Ratio	23330 to 23355	23330 to 23355	5MHz	QPSK, 16QAM	25RB
	23330 to 23355	23330	10MHz	QPSK, 16QAM	50RB
Frequency Stability	23330 to 23355	23330	5MHz	QPSK	1RB
	23330 to 23355	23330	10MHz	QPSK	1RB

Note:

- 1) The mark "V" means that this configuration is chosen for testing.
- 2) The mark "-" means that this configuration is not testing.
- 3) The low frequency, which started from 9 kHz to 30MHz, was pre-scanned and the result which was 20dB lower than the limit line was not reported.

2.3 BLOCK DIGRAM SHOWING THE CONFIGURATION OF SYSTEM TESTED FOR RADIATED

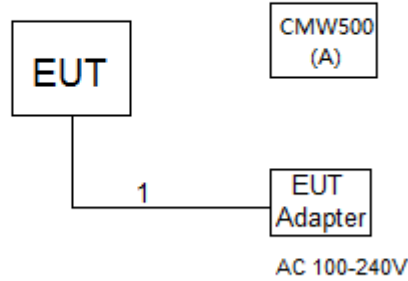

3.4 DESCRIPTION OF SUPPORT UNITS

The EUT has been tested as an independent unit together with other necessary accessories or support units. The following support units or accessories were used to form a representative test configuration during the tests.

Item	Equipment	Mfr/Brand	Model/Type No.	Series No.
1	CMW500	N/A	N/A	131463

Item	Cable Type	Shielded Type	Ferrite Core	Length
1	DC Cable	N/A	N/A	1.5m

3. TEST RESULT

3.1 OUTPUT POWER MEASUREMENT

3.1.1 LIMIT

Portable stations (hand-held devices) transmitting in the 758-768 MHz band and the 788-798 MHz band are limited to 3 watts ERP.

3.1.2 TEST PROCEDURE

The testing follows FCC KDB 971168 v03r01 Section 5.

ERP:

$EIRP = \text{Output Power} + \text{Antenan gain}$

Conducted Power:

The EUT was set up for the maximum power with LTE link data modulation and link up with simulator. Set the EUT to transmit under low, middle and high channel and record the power level shown on simulator.

3.1.3 TESTSETUP LAYOUT

Conducted Power Measurement

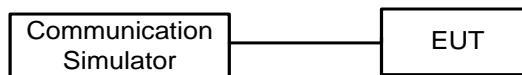

3.1.4 TEST DEVIATION

No deviation

3.1.5 TEST RESULTS

Please refer to the Appendix A.

3.2 OCCUPIED BANDWIDTH MEASUREMENT

3.2.1 TEST PROCEDURE

The testing follows FCC KDB 971168 v03r01 Section 4.

1. The EUT makes a call to the communication simulator. All measurements were done at low, middle and high operational frequency range. The communication simulator station system controlled a EUT to export maximum output power under transmission mode and specific channel frequency. Use OBW measurement function of Spectrum analyzer to measure 99 % occupied bandwidth and 26dB bandwidth.
2. The EUT was connected to spectrum analyzer and system simulator via a power divider.
3. $RBW=(1\% \sim 5\%)*EBW$
 $VBW \geq 3* RBW$
4. Set spectrum analyzer with Peak detector.

3.2.2 TEST SETUP LAYOUT

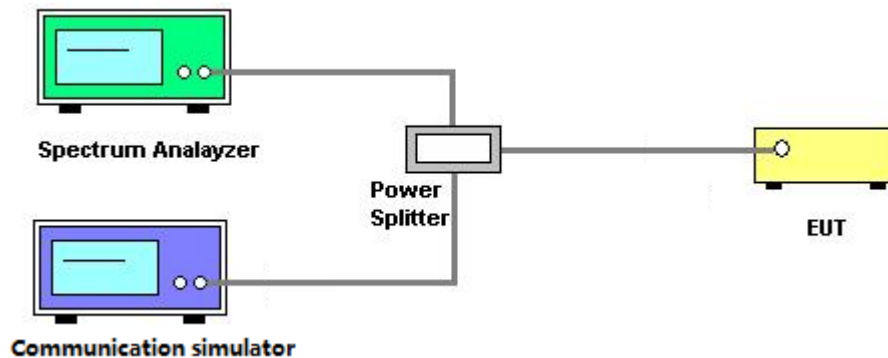

3.2.3 TEST DEVIATION

No deviation

3.2.4 TEST RESULTS

Please refer to the Appendix B.

3.3 CONDUCTED EMISSIONS MEASUREMENT

3.3.1 LIMIT

The power of any emission outside a licensee's frequency block shall be attenuated below the transmitter power (P) by at least $43 + 10 \log_{10}(P)$ dB. The limit of emission is equal to -13dBm.

3.3.2 TEST PROCEDURES

1. The testing follows FCC KDB 971168 v03 Section 6.0.
2. The EUT was connected to spectrum analyzer and system simulator via a power divider.
3. The band edges of low and high channels for the highest RF powers were measured. Set RBW $\geq 1\%$ EBW in the 1MHz band immediately outside and adjacent to the band edge.
4. Set spectrum analyzer with RMS detector.
5. The RF fundamental frequency should be excluded against the limit line in the operating frequency band.
6. The limit line is derived from $43 + 10 \log_{10}(P)$ dB below the transmitter power P(Watts)
 $= P(W) - [43 + 10 \log_{10}(P)](dB)$
 $= [30 + 10 \log_{10}(P)](dBm) - [43 + 10 \log_{10}(P)](dB)$
 $= -13dBm$

3.3.3 TESTSETUP LAYOUT

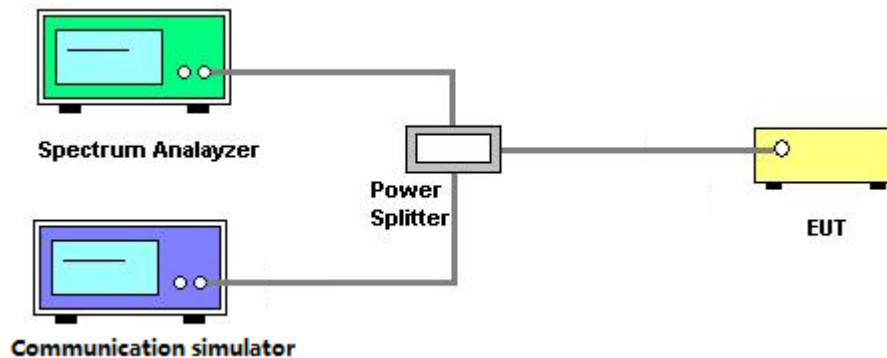

3.3.4 TESTDEVIATION

No deviation

3.3.5 TEST RESULTS

Please refer to the Appendix C.

3.4 RADIATED EMISSIONS MEASUREMENT

3.4.1 LIMIT

The power of any emission outside a licensee's frequency block shall be attenuated below the transmitter power (P) by at least $43 + 10 \log_{10}(P)$ dB. The limit of emission is equal to -13dBm .

3.4.2 TEST PROCEDURES

1. In the semi-anechoic chamber, EUT placed on the 0.8m height of Turn Table, rotated the table around 360 degrees to search the maximum radiation power and receiver antenna shall be rotated vertical and horizontal polarization and moved height from 1m to 4m to find the maximum polar radiated power. The "Read Value" is the spectrum reading the maximum power value.
2. The substitution horn antenna is substituted for EUT at the same position and signals generator export the CW signal to the substitution antenna via a TX cable. Rotated the Turn Table and moved receiving antenna to find the maximum radiation power. Adjust output power level of S.G to get a Value of spectrum reading equal to "Read Value" of step a. Record the power level of S.G
3. $\text{EIRP} = \text{Output power level of S.G} - \text{TX cable loss} + \text{Antenna gain of substitution horn}$.
4. E.R.P power can be calculated form E.I.R.P power by subtracting the gain of dipole, $\text{E.R.P power} = \text{E.I.P.R power} - 2.15\text{dBi}$.
5. The resolution bandwidth and video bandwidth of test receiver/spectrum analyzer is 1MHz/3MHz.

3.4.3 TESTSETUP LAYOUT

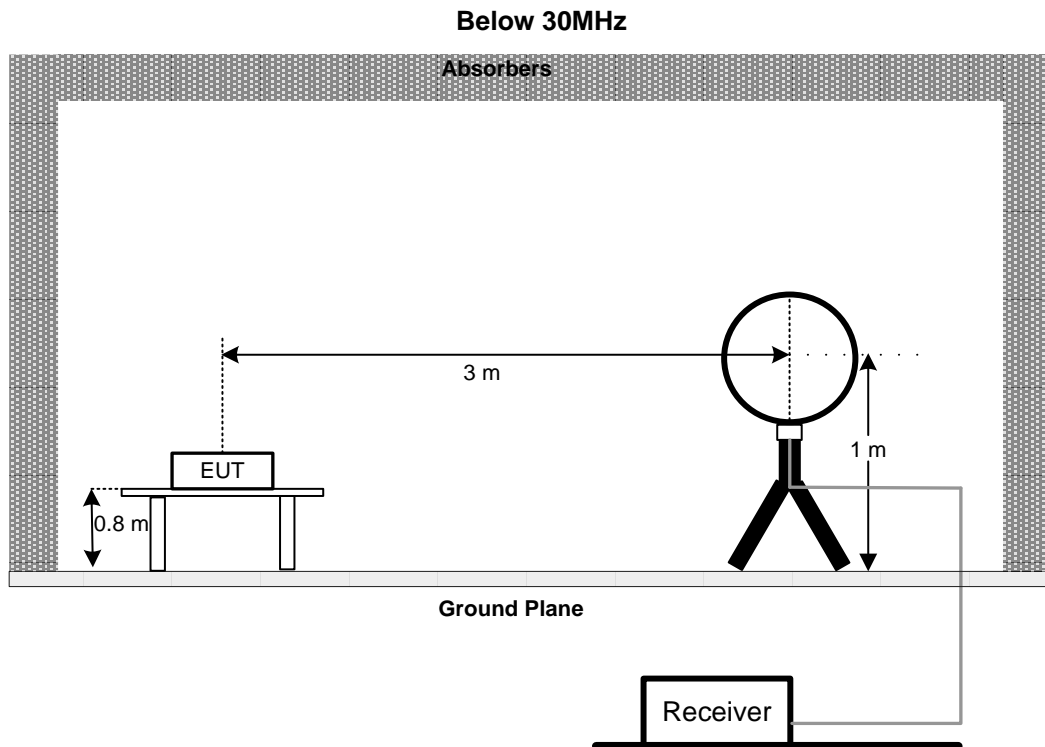

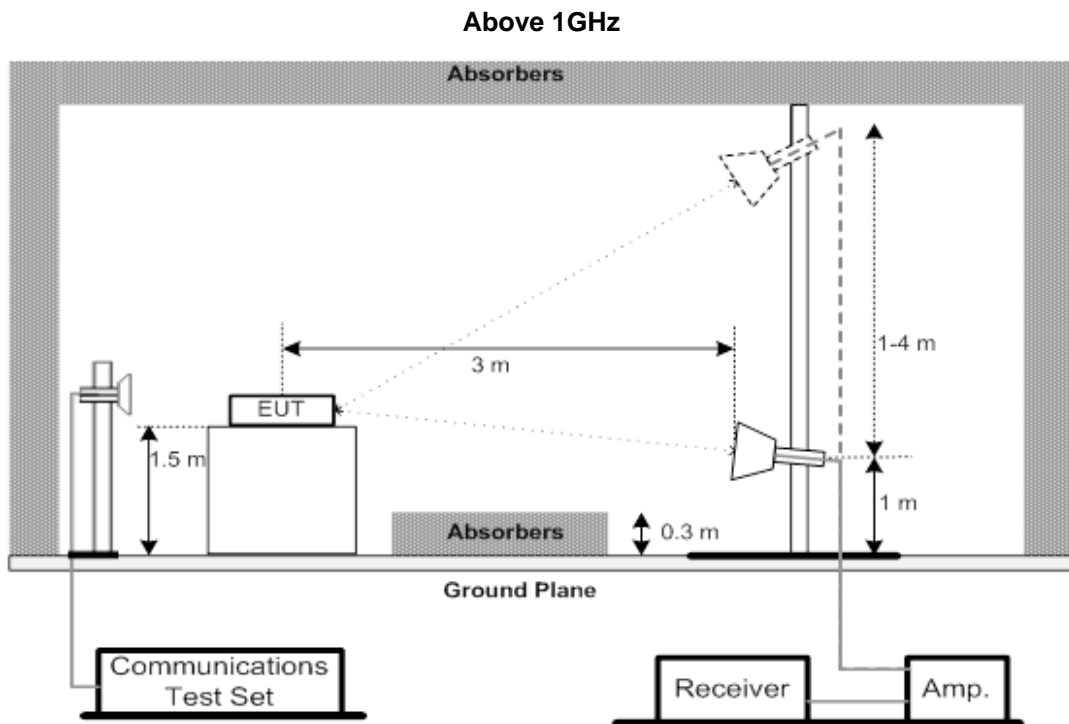
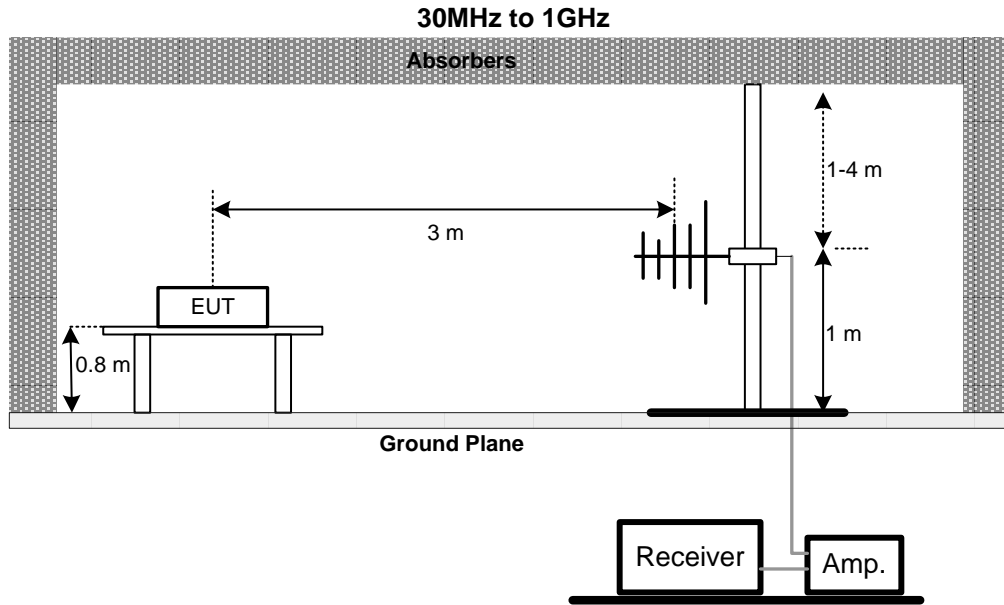

3.4.4 TESTDEVIATION

No deviation

3.4.5 TEST RESULTS (9KHZ TO 30MHZ)

Please refer to the APPENDIX D.

3.4.6 TEST RESULTS (30MHZ TO 1000MHZ)

Please refer to the APPENDIX E.

3.4.7 TEST RESULTS (ABOVE 1000MHZ)

Please refer to the APPENDIX F.

3.5 BAND EDGE /EMISSION MASK MEASUREMENT

3.5.1 LIMIT

For operations in the 758-768 MHz and the 788-798 MHz bands, the power of any emission outside the licensee's frequency band(s) of operation shall be attenuated below the transmitter power (P) within the licensed band(s) of operation, measured in watts, in accordance with the following:

(1) On all frequencies between 769-775 MHz and 799-805 MHz, by a factor not less than $76 + 10 \log(P)$ dB in a 6.25 kHz band segment, for base and fixed stations.

(2) On all frequencies between 769-775 MHz and 799-805 MHz, by a factor not less than $65 + 10 \log(P)$ dB in a 6.25 kHz band segment, for mobile and portable stations.

(3) On any frequency between 775-788 MHz, above 805 MHz, and below 758 MHz, by at least $43 + 10 \log(P)$ dB.

(4) Compliance with the provisions of paragraphs (e)(1) and (2) of this section is based on the use of measurement instrumentation such that the reading taken with any resolution bandwidth setting should be adjusted to indicate spectral energy in a 6.25 kHz segment.

(5) Compliance with the provisions of paragraph (e)(3) of this section is based on the use of measurement instrumentation employing a resolution bandwidth of 100 kHz or greater. However, in the 100 kHz bands immediately outside and adjacent to the frequency block, a resolution bandwidth of 30 kHz may be employed.

3.5.2 TEST PROCEDURES

1. All measurements were done at low and high operational frequency range.
2. Set RBW=1% of 26dBc bandwidth, VBW=3 X RBW, detector=RMS, Sweep time = Auto.
3. Record the max trace plot into the test report.

3.5.3 TESTSETUP LAYOUT

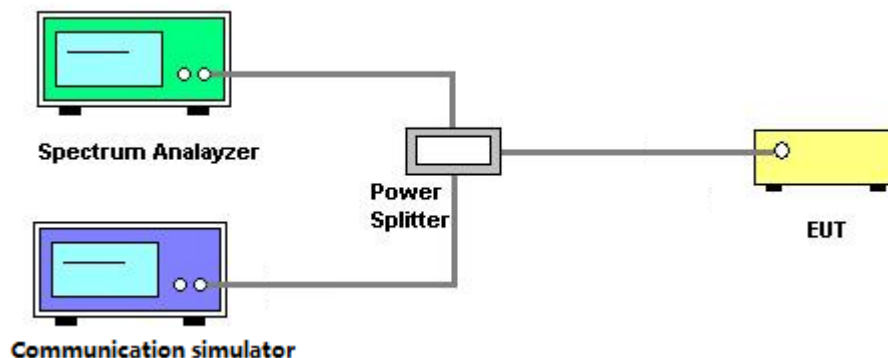

3.5.4 TESTDEVIATION

No deviation

3.5.5 TEST RESULTS

Please refer to the Appendix G.

3.6 PEAK TO AVERAGE RATIO MEASUREMENT

3.6.1 LIMIT

In measuring transmissions in this band using an average power technique, the peak to-average ratio (PAR) of the transmission may not exceed 13 dB.

3.6.2 TEST PROCEDURES

The testing follows FCC KDB 971168 v03r01 Section 5.7.

1. Set resolution/measurement bandwidth \geq signal's occupied bandwidth;
2. Set the number of counts to a value that stabilizes the measured CCDF curve;
3. Record the maximum PAPR level associated with a probability of 0.1%.

3.6.3 TEST SETUP LAYOUT

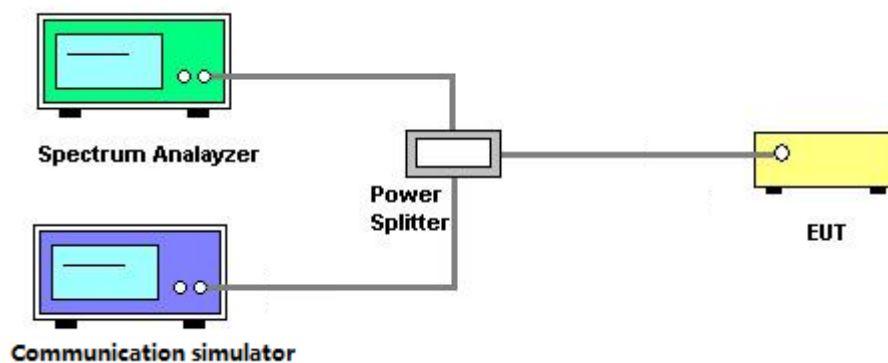

3.6.4 TEST DEVIATION

No deviation

3.6.5 TEST RESULTS

Please refer to the Appendix H.

3.7 FREQUENCY STABILITY MEASUREMENT

3.7.1 LIMIT

1.5 ppm is for base and fixed station. 2.5 ppm is for mobile station.

3.7.2 TEST PROCEDURES

The testing follows FCC KDB 971168 v03r01 Section 9.

1. Device is placed at the oven room. The oven room could control the temperatures and humidity. Power warm up is at least 15 min and power applied should perform before recording frequency error.
2. EUT is connected the external power supply to control the DC input power. The test voltage range is from minimum to maximum working voltage. Each step shall be record the frequency error rate.
3. The temperature range step is 10 degrees in this test items. All temperature levels shall be hold the $\pm 0.5^{\circ}\text{C}$ during the measurement testing. The each temperature step shall be at least 0.5 hours, consider the EUT could be test under the stability condition.
4. The frequency error was recorded frequency error from the communication simulator.

3.7.3 TESTSETUP LAYOUT

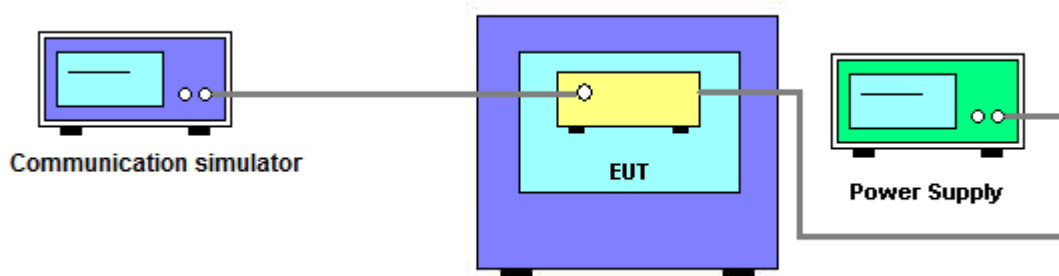

3.7.4 TESTDEVIATION

No deviation

3.7.5 TEST RESULTS

Please refer to the Appendix I.

4. LIST OF MEASUREMENT EQUIPMENTS

Radiated Emission Measurement(30M-1G)					
Item	Kind of Equipment	Manufacturer	Type No.	Serial No.	Calibrated until
1	TRILOG Broadband Antenna	Schwarzbeck	VULB 9168	719	Apr. 02, 2021
2	Pre-Amplifier	emci	EMC9135	980400	Mar. 21, 2021
3	MXE EMI Receiver	Keysight	N9038A	MY57150106	Mar. 21, 2021
4	Test Cable	emci	EMC104-SM-SM-7000	170330	Apr. 13, 2021
5	Test Cable	emci	EMC104-SM-SM-1000	170331	Apr. 13, 2021
6	Test Cable	emci	EMC104-SM-NM-3500	170621	Apr. 13, 2021
7	Measurement Software	Farad	EZ-EMC Ver.NB-03A1-01	N/A	Apr. 13, 2021
8	Wideband Radio Communication Test	R&S	CMW500	131463	Sep. 01, 2020

Radiated Emission Measurement(1G-18G)					
Item	Kind of Equipment	Manufacturer	Type No.	Serial No.	Calibrated until
1	Pre-Amplifier	emci	EMC184045SE	980409	Apr. 02, 2021
2	Pre-Amplifier	emci	EMC012645SE	980421	May. 11, 2021
3	Pre-Amplifier	emci	EMC9135	980400	Mar. 21, 2021
4	Double Ridged Broadband Horn Antenna	Schwarzbeck	BBHA 9120D	9120D-1787	Apr. 13, 2021
5	Double-Ridged Waveguide Horn Antenna	ETS-Lindgren	3116C	00203919	Apr. 13, 2021
6	TRILOG Broadband Antenna	Schwarzbeck	VULB 9168	719	Apr. 13, 2021
7	Cable	N/A	EMC102-SM-SM-6000	170336	N/A
8	Wideband Radio Communication Test	R&S	CMW500	131463	Sep. 01, 2020

Conducted Emission & Band Edge & Occupied Bandwidth Measurement					
Item	Kind of Equipment	Manufacturer	Type No.	Serial No.	Calibrated until
1	8960 SERIES 10 WIRELESS COMMUNICATIONS TEST SET	Agilent	E5515C	GB45070942	Sep. 01, 2020
2	Spectrum Analyzer	R&S	FSP40	100626	May. 06, 2021
3	EXA Spectrum Analyzer	Keysight	N9010A	MY56480579	Mar. 21, 2021
4	Power Divider	JUK	PD-2SF-2060	N/A	N/A

Frequency Stability Measurement					
Item	Kind of Equipment	Manufacturer	Type No.	Serial No.	Calibrated until
1	8960 SERIES 10 WIRELESS COMMUNICATIONS TEST SET	Agilent	E5515C	GB45070942	Sep. 01, 2020
2	Spectrum Analyzer	R&S	FSP40	100626	May. 06, 2021
3	EXA Spectrum Analyzer	Keysight	N9010A	MY56480579	Mar. 21, 2021
4	Power Divider	JUK	PD-2SF-2060	N/A	N/A
5	Temperature And Humidity Box	Blue pand	BPHS-120B	170616454	Sep. 01, 2020

Remark: "N/A" denotes no model name, serial no. or calibration specified.

All calibration period of equipment list is one year.

APPENDIX A - OUTPUT POWER

Output Power (dBm):

LTE Band / BW	Modulation	RB Size	RB Offset	Low CH	Mid CH	High CH
				23305CH	23330CH	23355CH
				790.5MHz	793MHz	795.5MHz
14 / 5M	QPSK	1	0	24.14	24.04	23.81
		1	13	24.03	24.25	23.95
		1	24	24.00	24.03	23.61
		12	0	23.23	23.10	23.11
		12	6	23.23	23.21	23.19
		12	11	23.21	23.21	23.03
		25	0	23.07	23.05	23.06
	16QAM	1	0	22.80	22.83	22.76
		1	13	22.79	23.04	22.76
		1	24	22.63	22.67	22.47
		12	0	22.05	22.03	22.07
		12	6	22.02	22.21	22.21
		12	11	22.07	22.15	22.02
		25	0	22.30	22.14	22.02

LTE Band / BW	Modulation	RB Size	RB Offset	Mid CH
				23330CH
				793MHz
14 / 10M	QPSK	1	0	24.31
		1	25	24.19
		1	49	24.09
		25	0	23.11
		25	13	23.14
		25	25	23.02
		50	0	23.02
	16QAM	1	0	22.93
		1	25	23.37
		1	49	23.24
		25	0	21.94
		25	13	22.04
		25	25	21.84
		50	0	21.92

ERP Power (dBm):

LTE Band / BW	Modulation	RB Size	RB Offset	Low CH	Mid CH	High CH
				23305CH	23330CH	23355CH
				790.5MHz	793MHz	795.5MHz
14 / 5M	QPSK	1	0	25.62	25.52	25.29
		1	13	25.51	25.73	25.43
		1	24	25.48	25.51	25.09
		12	0	24.71	24.58	24.59
		12	6	24.71	24.69	24.67
		12	11	24.69	24.69	24.51
	16QAM	25	0	24.55	24.53	24.54
		1	0	24.28	24.31	24.24
		1	13	24.27	24.52	24.24
		1	24	24.11	24.15	23.95
		12	0	23.53	23.51	23.55
		12	6	23.50	23.69	23.69
		12	11	23.55	23.63	23.50
		25	0	23.78	23.62	23.50

LTE Band / BW	Modulation	RB Size	RB Offset	Mid CH
				23330CH
				793MHz
14 / 10M	QPSK	1	0	25.79
		1	25	25.67
		1	49	25.57
		25	0	24.59
		25	13	24.62
		25	25	24.50
	16QAM	50	0	24.50
		1	0	24.41
		1	25	24.85
		1	49	24.72
		25	0	23.42
		25	13	23.52
		25	25	23.32
		50	0	23.40

APPENDIX B - OCCUPIED BANDWIDTH

LTE Band 14_5M					
QPSK			16QAM		
Channel	Frequency (MHz)	99% Occupied Bandwidth (MHz)	Channel	Frequency (MHz)	99% Occupied Bandwidth (MHz)
23305	790.5	4.5241	23305	790.5	4.5018
23330	793.0	4.5039	23330	793.0	4.5037
23355	795.5	4.5215	23355	795.5	4.4975
Channel	Frequency (MHz)	26dB Bandwidth (MHz)	Channel	Frequency (MHz)	26dB Bandwidth (MHz)
23305	790.5	4.9830	23305	790.5	4.8980
23330	793.0	4.9070	23330	793.0	4.8530
23355	795.5	4.9700	23355	795.5	4.8680

Spectrum Plot

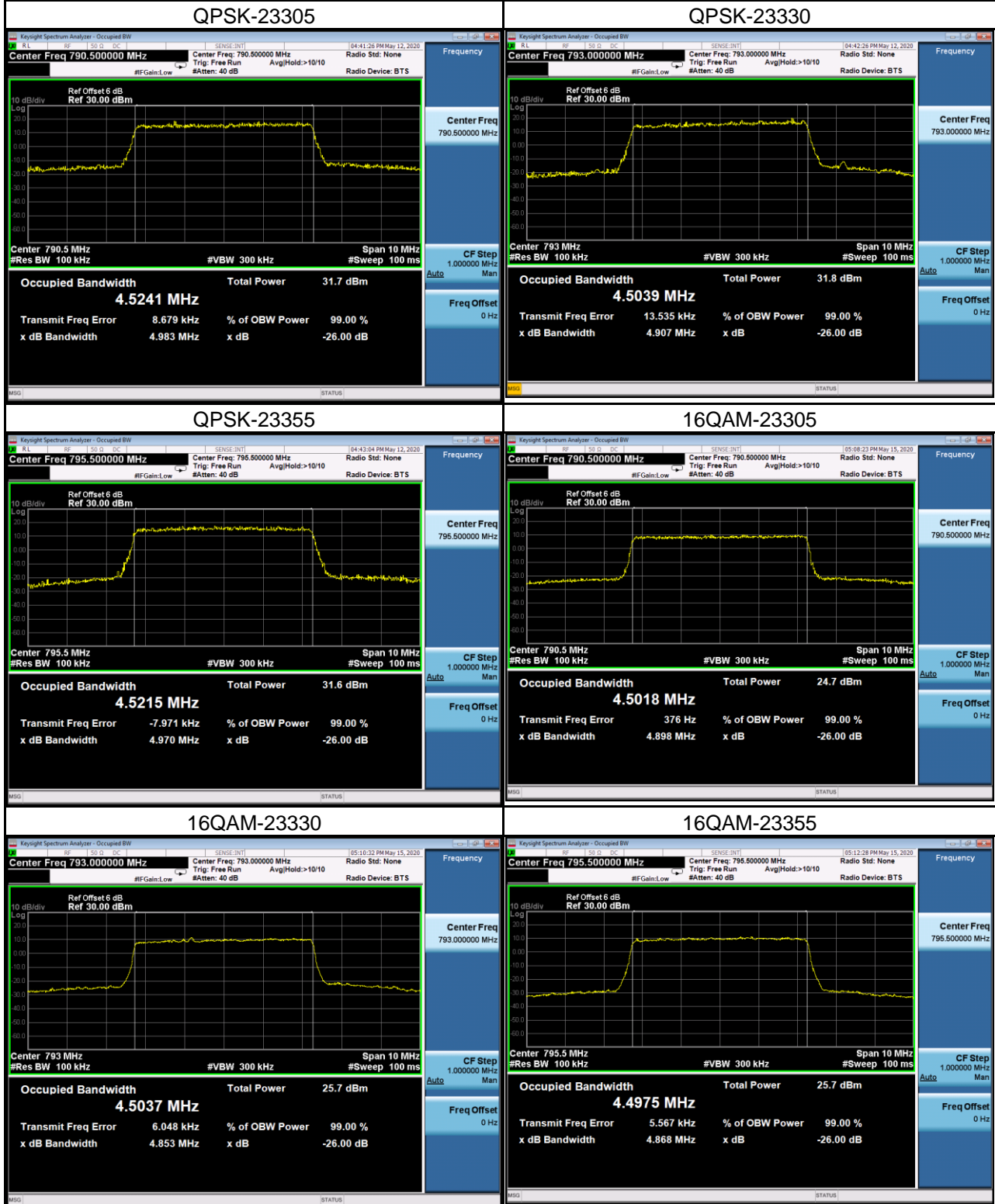

LTE Band 14_10M					
QPSK			16QAM		
Channel	Frequency (MHz)	99% Occupied Bandwidth (MHz)	Channel	Frequency (MHz)	99% Occupied Bandwidth (MHz)
23330	793.0	8.9474	23330	793.0	8.9675
Channel	Frequency (MHz)	26dB Bandwidth (MHz)	Channel	Frequency (MHz)	26dB Bandwidth (MHz)
23330	793.0	9.8210	23330	793.0	9.5330

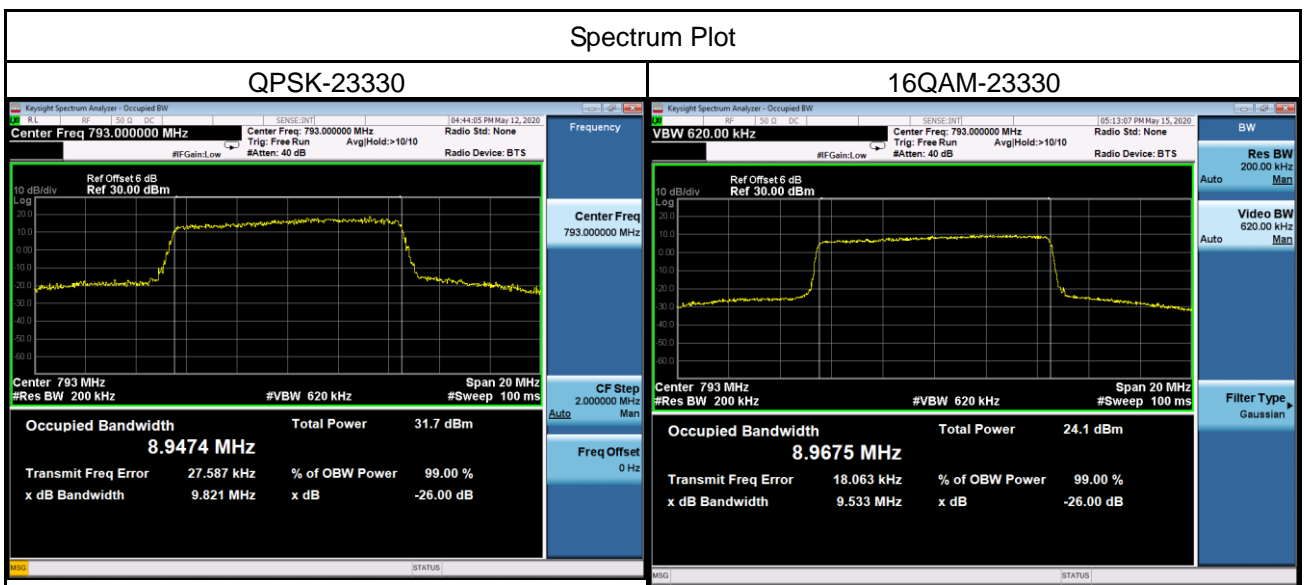

APPENDIX C - CONDUCTED EMISSIONS

LTE Band 14_5M Spectrum Plot			
Channel	Frequency(MHz)	Channel	Frequency(MHz)
23305	790.5	23330	793.0
<p>Date: 3.JUN.2020 15:16:41</p>		<p>Date: 3.JUN.2020 15:19:52</p>	
Channel	Frequency(MHz)	-	-
23355	795.5	-	-
<p>Date: 3.JUN.2020 17:41:47</p>		-	

LTE Band 14_10M Spectrum Plot			
Channel	Frequency(MHz)	Channel	Frequency(MHz)
23330	793.0	23330	793.0
<p>Date: 3 JUN. 2020 15:16:49</p>		<p>Date: 3 JUN. 2020 15:19:52</p>	
Channel	Frequency(MHz)	-	-
23330	793.0	-	-
<p>Date: 3 JUN. 2020 17:43:06</p>		-	

APPENDIX D - RADIATED SPURIOUS EMISSIONS (9KHZ TO 30MHZ)

Note: Below 30MHz, The measured value have enough margin over 20dB than the limit, therefore they are not reported

APPENDIX E - RADIATED EMISSION (30MHZ TO 1GHZ)

Test Mode: LTE Band 14_TX Mode_5M

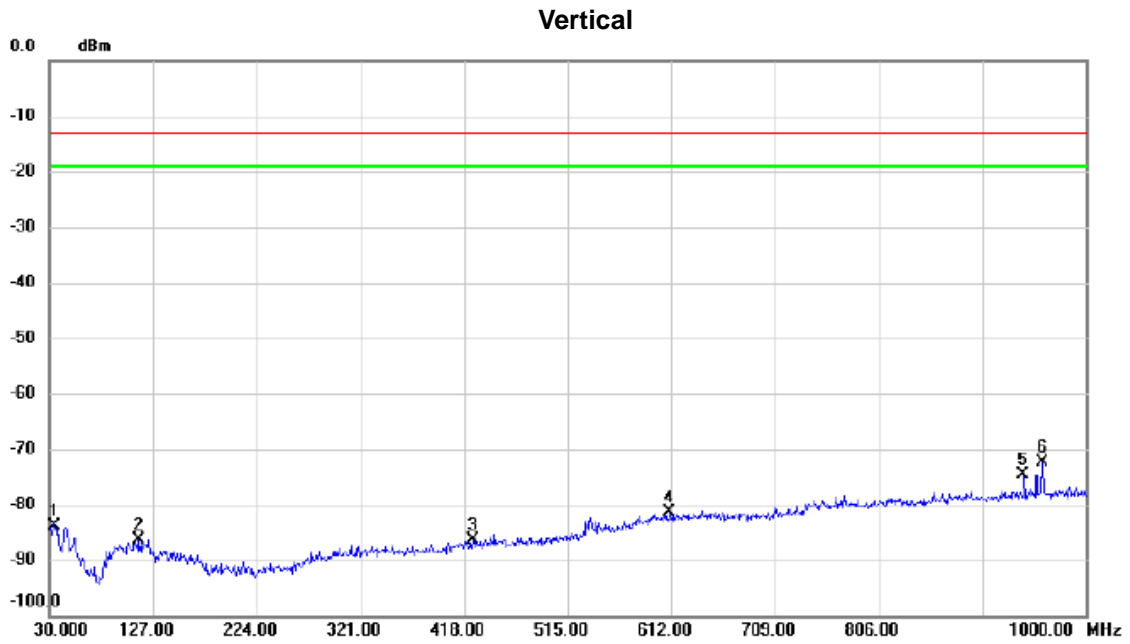

No.	Mk.	Freq. MHz	Reading Level dBm	Correct Factor dB	Measure- ment dBm	Limit dBm	Margin dB	Detector	Comment
1		35.1410	-66.71	-17.22	-83.93	-13.00	-70.93	peak	
2		113.1290	-68.66	-17.83	-86.49	-13.00	-73.49	peak	
3		426.1480	-73.39	-12.99	-86.38	-13.00	-73.38	peak	
4		610.0600	-72.71	-8.62	-81.33	-13.00	-68.33	peak	
5		941.7030	-69.46	-5.19	-74.65	-13.00	-61.65	peak	
6	*	959.6480	-67.30	-5.09	-72.39	-13.00	-59.39	peak	

Test Mode: LTE Band 14_TX Mode_5M

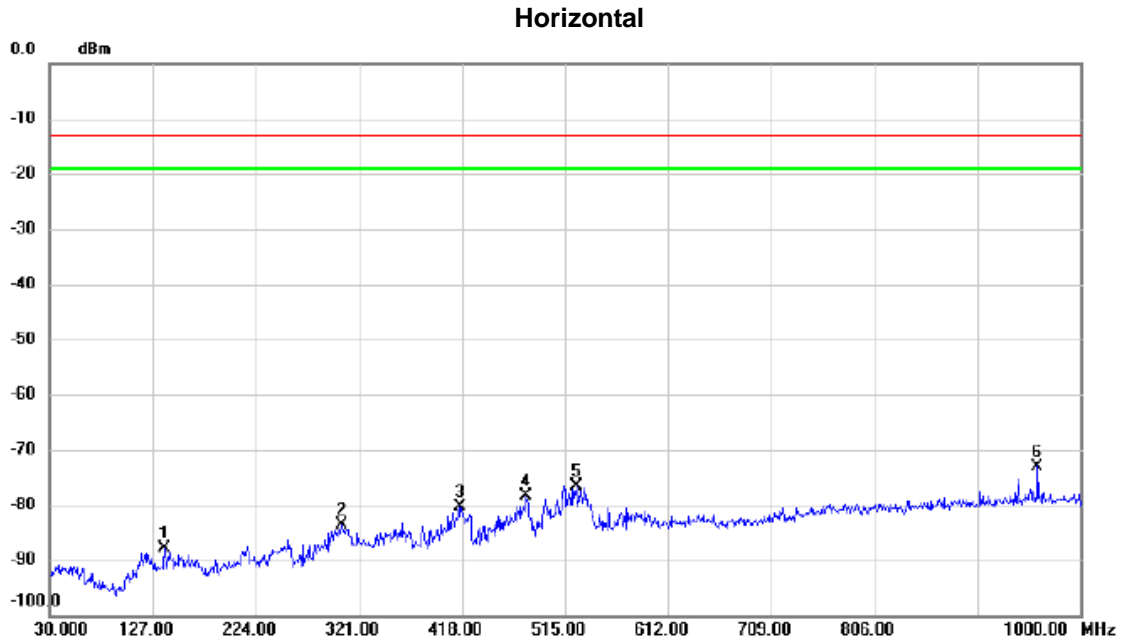

No.	Mk.	Freq. MHz	Reading Level dBm	Correct Factor dB	Measure- ment dBm	Limit dBm	Margin dB	Detector	Comment
1		137.6700	-71.82	-15.97	-87.79	-13.00	-74.79	peak	
2		304.7040	-69.40	-14.25	-83.65	-13.00	-70.65	peak	
3		415.9630	-67.28	-13.19	-80.47	-13.00	-67.47	peak	
4		478.1400	-65.60	-12.83	-78.43	-13.00	-65.43	peak	
5		525.4760	-64.59	-11.92	-76.51	-13.00	-63.51	peak	
6	*	959.6480	-67.91	-5.09	-73.00	-13.00	-60.00	peak	

APPENDIX F - RADIATED EMISSION (ABOVE 1GHZ)

Test Mode: LTE Band 14_TX CH23330_5M

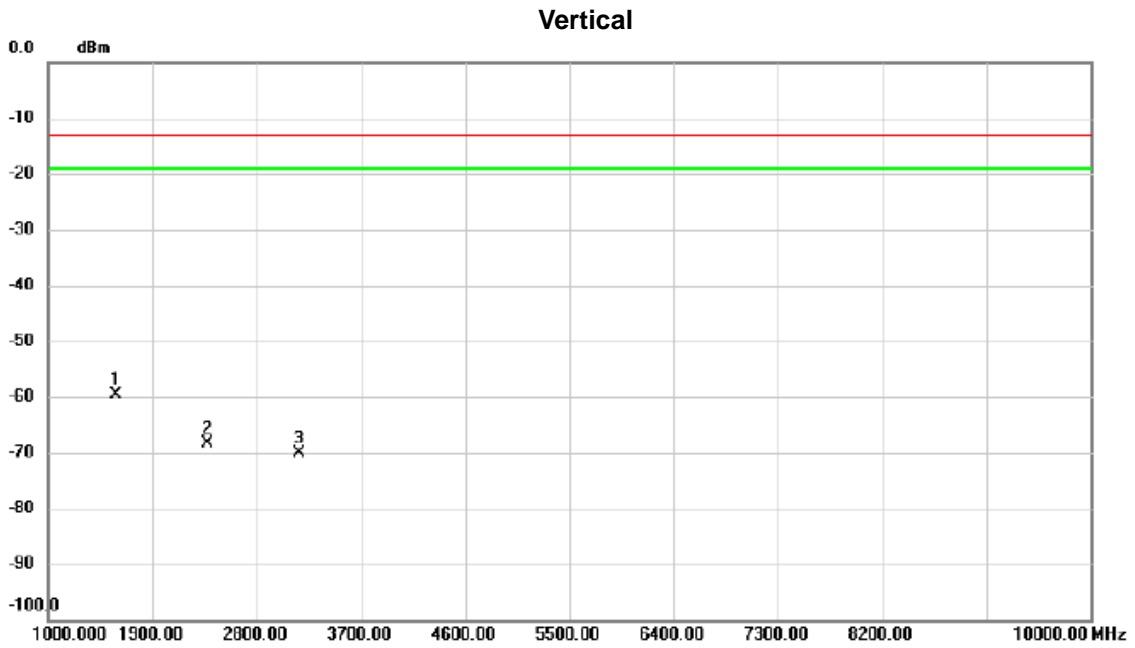

No.	Mk.	Freq. MHz	Reading Level dBm	Correct Factor dB	Measure- ment dBm	Limit dBm	Margin dB	Detector	Comment
1	*	1581.700	-36.73	-22.97	-59.70	-13.00	-46.70	peak	
2		2372.250	-48.52	-19.89	-68.41	-13.00	-55.41	peak	
3		3163.000	-52.31	-17.88	-70.19	-13.00	-57.19	peak	

Test Mode: LTE Band 14_TX CH23330_5M

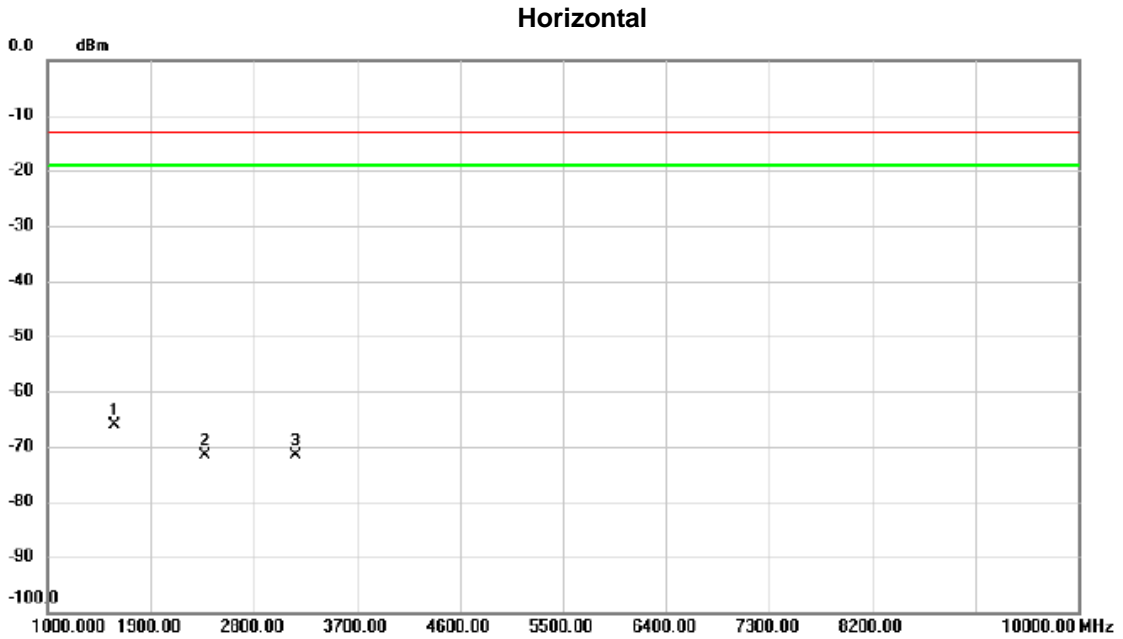

No.	Mk.	Freq. MHz	Reading Level dBm	Correct Factor dB	Measure- ment dBm	Limit dBm	Margin dB	Detector	Comment
1	*	1581.700	-43.05	-22.97	-66.02	-13.00	-53.02	peak	
2		2372.250	-51.80	-19.89	-71.69	-13.00	-58.69	peak	
3		3163.000	-53.63	-17.88	-71.51	-13.00	-58.51	peak	

Test Mode: LTE Band 14_TX CH23330_10M

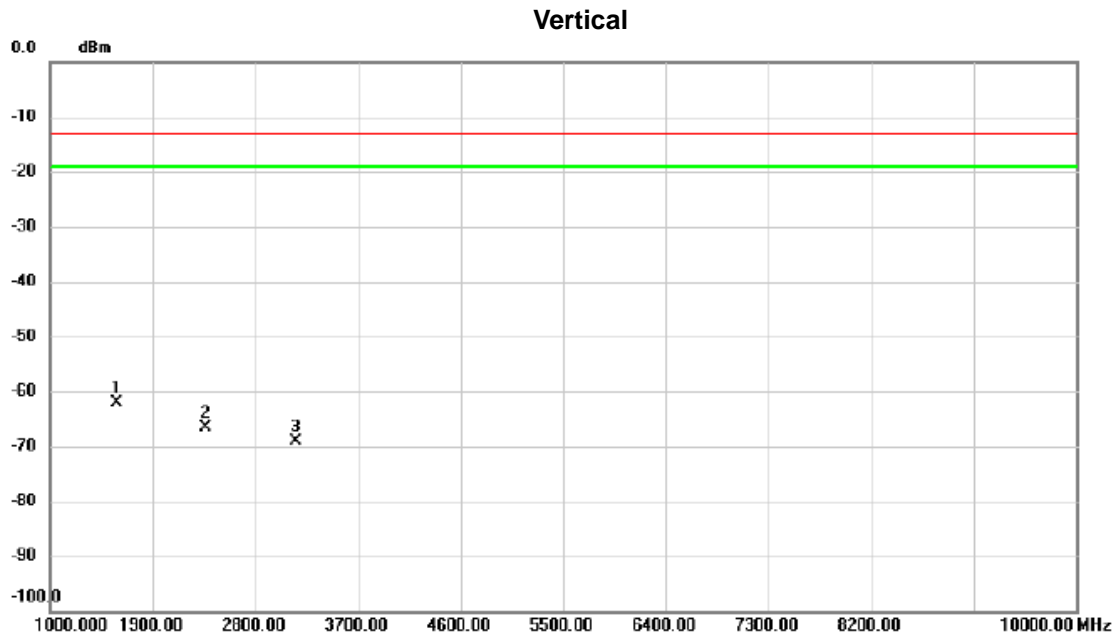

No.	Mk.	Freq. MHz	Reading Level dBm	Correct Factor dB	Measure- ment dBm	Limit dBm	Margin dB	Detector	Comment
1	*	1577.500	-39.10	-22.99	-62.09	-13.00	-49.09	peak	
2		2365.500	-46.77	-19.92	-66.69	-13.00	-53.69	peak	
3		3154.000	-51.32	-17.89	-69.21	-13.00	-56.21	peak	

Test Mode: LTE Band 14_TX CH23330_10M

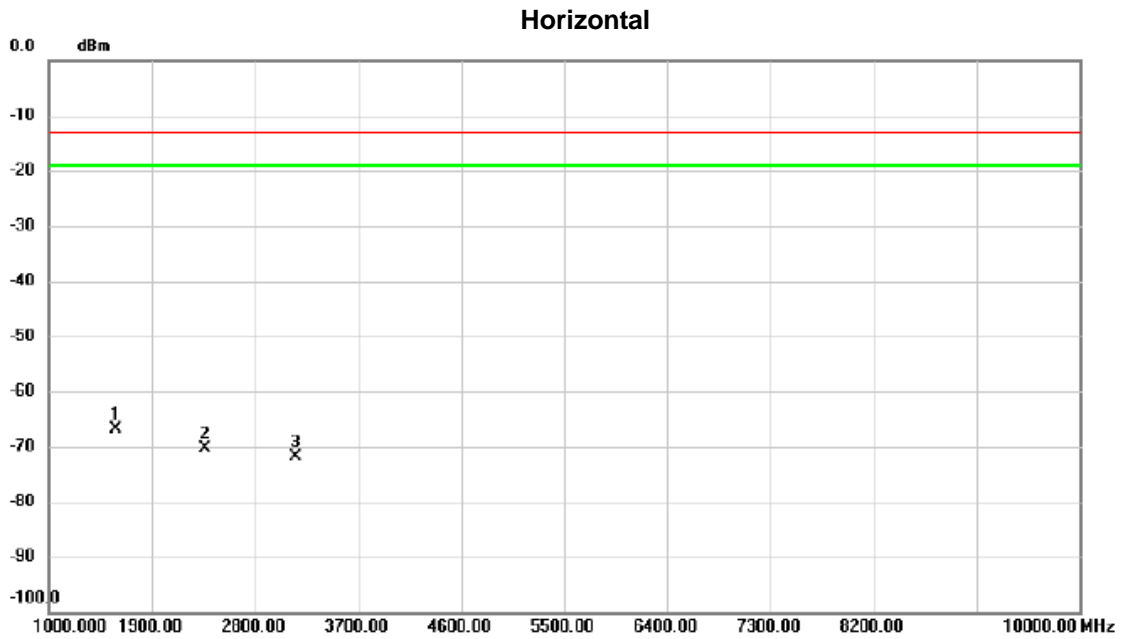

No.	Mk.	Freq. MHz	Reading Level dBm	Correct Factor dB	Measure- ment dBm	Limit dBm	Margin dB	Detector	Comment
1	*	1577.500	-43.97	-22.99	-66.96	-13.00	-53.96	peak	
2		2365.500	-50.47	-19.92	-70.39	-13.00	-57.39	peak	
3		3154.000	-54.08	-17.89	-71.97	-13.00	-58.97	peak	

APPENDIX G - BAND EDGE

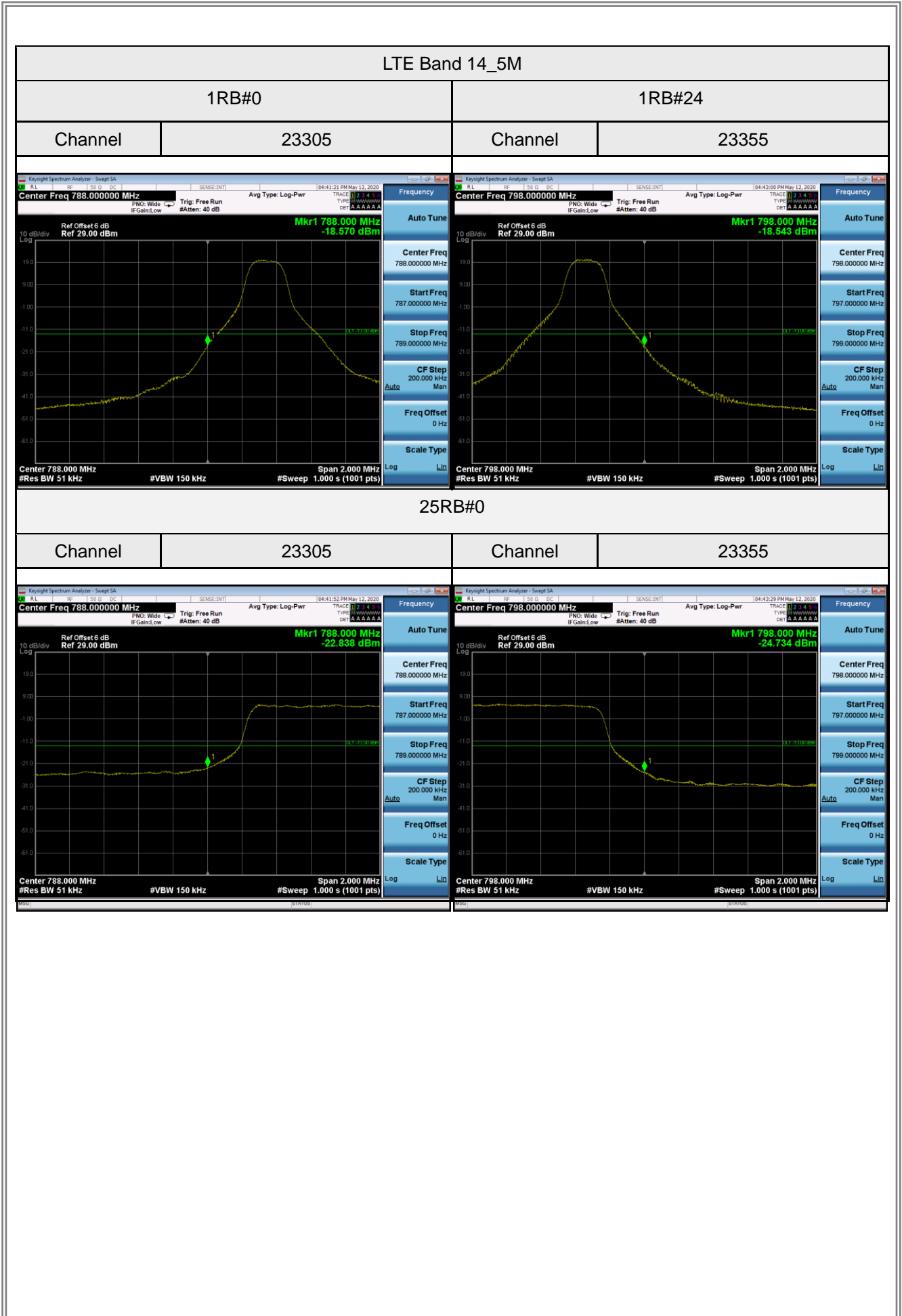

APPENDIX H - PEAK TO AVERAGE RATIO

LTE Band 14 Spectrum Plot_5M



LTE Band 14 Spectrum Plot_10M

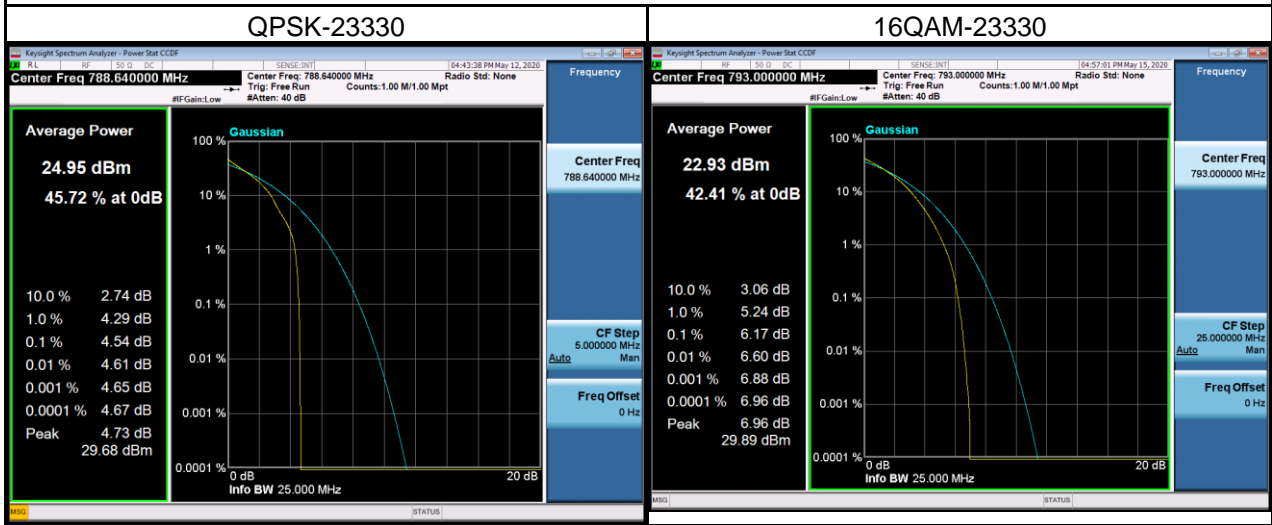

APPENDIX I - FREQUENCY STABILITY

Test Mode:	LTE Band 14_CH23330_5M
------------	------------------------

Temperature vs. Frequency Stability

Temperature(°C)	Frequency Error (Hz)	Frequency Error (ppm)	Limit(ppm)
-20	2.04	0.002572509	±2.5
-10	-4.67	-0.005889029	
0	3.35	0.004224464	
10	0.86	0.001084489	
20	-1.76	-0.00221942	
30	2.32	0.002925599	
40	3.13	0.003947037	
50	5.66	0.007137453	
Max. Deviation (ppm)	5.66	0.007137453	

Voltage vs. Frequency Stability

Voltage(Volts)	Frequency Error (Hz)	Frequency Error (ppm)	Limit(ppm)
3.55	5.75	0.007250946	±2.5
3.80	-4.70	-0.00592686	
4.20	3.92	0.004943253	
Max. Deviation (ppm)	5.75	0.007250946	

Test Mode:	LTE Band 14_CH23330_10M
------------	-------------------------

Temperature vs. Frequency Stability

Temperature(°C)	Frequency Error (Hz)	Frequency Error (ppm)	Limit(ppm)
-20	2.81	0.003543506	±2.5
-10	-2.89	-0.003644388	
0	-2.82	-0.003556116	
10	-3.87	-0.004880202	
20	3.47	0.004375788	
30	-0.09	-0.000113493	
40	4.14	0.005220681	
50	-4.29	-0.005409836	
Max. Deviation (ppm)	-4.29	-0.005409836	

Voltage vs. Frequency Stability

Voltage(Volts)	Frequency Error (Hz)	Frequency Error (ppm)	Limit(ppm)
3.55	-5.77	-0.007276166	±2.5
3.80	-2.70	-0.003404792	
4.20	-5.45	-0.006872636	
Max. Deviation (ppm)	-5.77	-0.007276166	

End of Test Report