

S

T

S

L

A

B



# RADIO TEST REPORT

Report No.: STS2302331W01

Issued for

Telo Communication (Shenzhen) Co., Ltd

6/F, No. 42 Liuxian 1st Road, Bao'an District, Shenzhen,  
China

<b>Product Name:</b>	Smart LTE Terminal
<b>Brand Name:</b>	TELOX
<b>Model Name:</b>	TE320
<b>Series Model:</b>	TE320L, TE320A, TE320M, TE320G, TE320P, TE320X
<b>FCC ID:</b>	2AYEZ-TE320
<b>Test Standard:</b>	47 CFR Part 2, 22, 24, 27, 90

Any reproduction of this document must be done in full. No single part of this document may be reproduced without permission from STS, all test data presented in this report is only applicable to presented test sample.

Shenzhen STS Test Services Co., Ltd.  
A 1/F, Building B, Zhuoke Science Park, No.190 Chongqing Road, HepingShequ,  
Fuyong Sub-District, Bao'an District, Shenzhen, Guang Dong, China  
TEL: +86-755 3688 6288 FAX: +86-755 3688 6277 E-mail:sts@stsapp.com





TEST RESULT CERTIFICATION

Applicant's Name .....: Telo Communication (Shenzhen) Co., Ltd
Address.....: 6/F, No. 42 Liuxian 1st Road, Bao'an District, Shenzhen, China
Manufacturer's Name .....: Telo Communication (Shenzhen) Co., Ltd
Address.....: 6/F, No. 42 Liuxian 1st Road, Bao'an District, Shenzhen, China

Product Description

Product Name .....: Smart LTE Terminal
Brand Name .....: TELOX
Model Name.....: TE320
Series Model .....: TE320L, TE320A, TE320M, TE320G, TE320P, TE320X
Test Standards .....: 47 CFR Part 2, 22, 24, 27, 90
Test Procedure .....: KDB 971168 D01 v03r01,ANSI C63.26( 2015)

This device described above has been tested by STS, the test results show that the equipment under test (EUT) is in compliance with the FCC requirements. And it is applicable only to the tested sample identified in the report.
This report shall not be reproduced except in full, without the written approval of STS, this document may be altered or revised by STS, personal only, and shall be noted in the revision of the document..

Date of Test.....:
Date of receipt of test item .....: 28 Feb. 2023
Date (s) of performance of tests : 28 Feb. 2023 ~ 23 Mar. 2023
Date of Issue .....: 23 Mar. 2023
Test Result .....: Pass

Testing Engineer : [Signature]
(Chris Chen)

Technical Manager : [Signature]
(Sean she)

Authorized Signatory : [Signature]
(Bovey Yang)





Table of Contents	Page
<b>1 INTRODUCTION</b>	<b>7</b>
1.1 TEST FACTORY	7
1.2 MEASUREMENT UNCERTAINTY	7
<b>2 PRODUCT INFORMATION</b>	<b>8</b>
<b>3 TEST CONFIGURATION OF EQUIPMENT UNDER TEST</b>	<b>12</b>
<b>4 MEASUREMENT INSTRUMENTS</b>	<b>15</b>
<b>5 TEST ITEMS</b>	<b>16</b>
5.1 CONDUCTED OUTPUT POWER&TRANSMITTER RADIATED POWER	16
5.2 PEAK TO AVERAGE RATIO	69
5.3 OCCUPIED BANDWIDTH	70
5.4 FREQUENCY STABILITY	71
5.5 SPURIOUS EMISSIONS AT ANTENNA TERMINALS	88
5.6 BAND EDGE	89
5.7 FIELD STRENGTH OF SPURIOUS RADIATION MEASUREMENT	91
<b>APPENDIX-PHOTOS OF TEST SETUP</b>	<b>151</b>

**Revision History**

Rev.	Issue Date	Report NO.	Effect Page	Contents
00	23 Mar. 2023	STS2302331W01	ALL	Initial Issue





SUMMARY OF TEST RESULTS

Test procedures according to the technical standards:

The radiated emission testing was performed according to the procedures of KDB 971168 D01 v03r01 and ANSI C63.26( 2015)

Test Description	FCC Rules	Band	Test Limit	Test Result
Conducted Output Power	2.1046	/	Reporting Only	PASS
Transmitter Radiated Power	22.913	B5, B26	ERP < 7 Watt	PASS
	24.232(c)	B2	EIRP < 2Watt	
	27.50(b)	B13	ERP < 3 Watt	
	27.50(c)	B12, B17	ERP < 3 Watt	
	27.50(d)	B4, B66	EIRP < 1Watt	
	27.50(h)	B7, B41	EIRP < 2Watt	
	90.635(b)	B26	ERP < 100Watt	
Peak-to-Average Ratio	22.913(d)	B5, B26	< 13 dB	PASS
	24.232(d)	B2		
	27.50	B4, B7, B12, B13, B17, B41, B66		
Occupied Bandwidth	2.1049	/	Reporting Only	PASS
Frequency Stability	2.1055	/	< 2.5 ppm	PASS
	22.355	B5, B26		
	24.235	B2		
	27.54	B4, B7, B12, B13, B17, B41, B66		
	90.213	B26		
Spurious Emission at Antenna Terminals	2.1051	/	< 43+10log10(P[Watts])	PASS
	22.917	B5, B26		



	24.238(a)	B2		
	27.53(c)	B13		
	27.53(g)	B12, B17		
	27.53(h)	B4, B66		
	90.691	B26		
	27.53(m)	B7, B41		
Band Edge	2.1051	/	Please refer to standard	PASS
	22.917	B5, B26		
	24.238(a)	B2		
	27.53(c)	B13		
	27.53(g)	B12, B17		
	27.53(h)	B4, B66		
	27.53(m)	B7, B41		
	90.691	B26		
Field Strength of Spurious Radiation	2.1053	/	< 43+10log10(P[Watts])	PASS
	22.917	B5, B26		
	24.238(a)	B2		
	27.53(c)	B13		
	27.53(g)	B12, B17		
	27.53(h)	B4, B66		
	90.691	B26		
	27.53(m)	B7, B41	< 55+10log10(P[Watts])	



## 1 INTRODUCTION

### 1.1 TEST FACTORY

SHENZHEN STS TEST SERVICES CO., LTD

Add. : A 1/F, Building B, Zhuoke Science Park, No.190 Chongqing Road, HepingShequ, Fuyong Sub-District, Bao'an District, Shenzhen, Guang Dong, China

FCC test Firm Registration Number: 625569

IC test Firm Registration Number: 12108A

A2LA Certificate No.: 4338.01

### 1.2 MEASUREMENT UNCERTAINTY

The measurement uncertainties shown below were calculated in accordance with the requirements of ANSI C63.4-2014. All measurement uncertainty values are shown with a coverage factor of  $k = 2$  to indicate a 95% level of confidence. The measurement data shown herein meets or exceeds the CISPR measurement uncertainty values specified in CISPR 16-4-2 and, thus, can be compared directly to specified limits to determine compliance.

No.	Item	Uncertainty
1	RF output power, conducted	$\pm 1.197\text{dB}$
2	Unwanted Emissions, conducted	$\pm 2.896\text{dB}$
3	All emissions, radiated 9K-30MHz	$\pm 3.84\text{dB}$
4	All emissions, radiated 30M-1GHz	$\pm 3.94\text{dB}$
5	All emissions, radiated 1G-6GHz	$\pm 4.59\text{dB}$
6	All emissions, radiated >6G	$\pm 5.22\text{dB}$
7	Conducted Emission (9KHz-150KHz)	$\pm 2.14\text{dB}$
8	Conducted Emission (150KHz-30MHz)	$\pm 2.54\text{dB}$





## 2 PRODUCT INFORMATION

Product Name	Smart LTE Terminal
Trade Name	TELOX
Model Name	TE320
Series Model	TE320L, TE320A, TE320M, TE320G, TE320P, TE320X
Model Difference	It's just a different model name
Tx Frequency:	GPRS/EDGE: 850: 824 MHz ~ 849MHz 1900: 1850 MHz ~ 1910MHz WCDMA: Band V: 824 MHz ~ 849 MHz Band II: 1850 MHz ~ 1910 MHz Band IV: 1710 MHz ~ 1755 MHz LTE: Band 2:1850~1910MHz Band 4:1710~1755MHz Band 5:824~849MHz Band 7:2500~2570MHz Band 12:699~716MHz Band 13:777~787MHz Band 17:704~716MHz Band 26:814~849MHz Band 41:2555~2655MHz Band 66:1710~1780MHz
Rx Frequency:	GPRS/EDGE: 850: 869 MHz ~ 894 MHz 1900: 1930 MHz ~ 1990MHz WCDMA: Band V: 869 MHz ~ 894 MHz Band II: 1930 MHz ~ 1990 MHz Band IV: 2110 MHz ~ 2155 MHz LTE: Band 2:1930~1990MHz Band 4:2110~2155MHz Band 5:869~894MHz Band 7:2620~2690MHz Band 12:729~746MHz Band 13:746~756MHz





	<p>Band 17:734~746MHz</p> <p>Band 26:859~894MHz</p> <p>Band 41:2555~2655MHz</p> <p>Band 66:2110~2200MHz</p>
Max RF Output Power:	<p>GPRS850(1-Slot):32.72dBm, GPRS1900(1-Slot):30.14dBm</p> <p>GPRS850(2-Slot):32.08dBm, GPRS1900(2-Slot):29.53dBm</p> <p>GPRS850(3-Slot):30.40dBm, GPRS1900(3-Slot):27.96dBm</p> <p>GPRS850(4-Slot):29.30dBm, GPRS1900(4-Slot):26.87dBm</p> <p>EDGE 850(1-Slot):27.00dBm, EDGE 1900(1-Slot):26.68dBm</p> <p>EDGE 850(2-Slot):25.76dBm, EDGE 1900(2-Slot):25.76dBm</p> <p>EDGE 850(3-Slot):24.19dBm, EDGE 1900(3-Slot):23.43dBm</p> <p>EDGE 850(4-Slot):22.76dBm, EDGE 1900(4-Slot):21.99dBm</p> <p>WCDMA Band V:23.52dBm, WCDMA Band II:22.65dBm</p> <p>WCDMA Band IV:21.78dBm</p> <p>LTE B2: 24.19dBm, LTE B4: 23.57dBm, LTE B5: 24.39dBm, LTE B7: 23.88dBm, LTE B12: 24.01dBm, LTE B13: 24.29dBm, LTE B17: 24.62dBm, LTE B26: 24.59dBm, LTE B41: 22.05dBm, LTE B66: 24.32 dBm</p>
Modulation Characteristics:	<p>GMSK for GPRS; GMSK and 8PSK for EDGE</p> <p>WCDMA: QPSK; HSDPA:QPSK/16QAM; HSUPA:BPSK</p> <p>LTE: QPSK /16QAM</p>
SIM Card:	<p>SIM 1 and SIM 2 is a chipset unit and tested as single chipset, SIM 1 is used to tested.</p>
Antenna:	<p>PIFA</p>
Antenna gain:	<p>GSM850: 0.15dBi, GSM1900: 0.23dBi;</p> <p>WCDMA B2: 0.18dBi, WCDMA B4: 0.31dBi, WCDMA B5: 0.15dBi;</p> <p>LTE B2: 0.26dBi, LTE B4: 0.23 dBi, LTE B5:0.15dBi, LTE B7:0.27dBi,</p> <p>LTE B12: 0.05dBi, LTE B13: 0.12dBi, LTE B17: 0.05 dBi, LTE B26: 0.05dBi, LTE B41: 0.23dBi, LTE B66: 0.26dBi</p>
Battery parameter:	<p>Rated Voltage:3.8 V</p> <p>Capacity: 4000mAh</p>
Adapter:	<p>Input: AC100V-240V, 50.60Hz, 0.3A</p> <p>Output:5V, 2A</p>
GPRS/EDGE Class:	<p>Multi-Class12</p>
Extreme Vol. Limits:	<p>DC 3.6V~ DC 4.35V(Normal: DC 3.8V)</p>
Extreme Temp. Tolerance:	<p>-30°C to +50°C</p>
Hardware version number:	<p>PL21_V1.0</p>
Software version number:	<p>TE320_INT_V1P_230214</p>
<p><b>** Note: The High Voltage 4.35V and Low Voltage 3.6 V was declared by manufacturer, The EUT couldn't be operate normally with higher or lower voltage, the antenna information refer the manufacturer provide report, applicable only to the tested sample identified in the report.</b></p>	



2.1 EMISSION DESIGNATOR

Mode	Emission Designator (99%OBW)	
GPRS850	249KGXW	
EGPRS850	247KG7W	
GPRS1900	246KGXW	
EGPRS1900	259KG7W	
Mode	Emission Designator (99%OBW)	
WCDMA 850	4M18F9W	
WCDMA 1700	4M19F9W	
WCDMA 1900	4M19F9W	
LTE Band 2	Emission Designator	Emission Designator
BW(MHz)	(99%OBW)QPSK	(99%OBW)16QAM
1.4	1M09G7D	1M10W7D
3	2M69G7D	2M69W7D
5	4M251G7D	4M54W7D
10	9M0G7D	8M99W7D
15	13M47G7D	13M56W7D
20	18M02G7D	18M01W7D
LTE Band 4	Emission Designator	Emission Designator
BW(MHz)	(99%OBW)QPSK	(99%OBW)16QAM
1.4	1M09G7D	1M09W7D
3	2M69G7D	2M69W7D
5	4M54G7D	4M52W7D
10	9M01G7D	9M01W7D
15	13M51G7D	13M53W7D
20	17M95G7D	18M02W7D
LTE Band 5	Emission Designator	Emission Designator
BW(MHz)	(99%OBW)QPSK	(99%OBW)16QAM
1.4	1M09G7D	1M09W7D
3	2M69G7D	2M69W7D
5	4M54G7D	4M53W7D
10	9M01G7D	9M00W7D
LTE Band 7	Emission Designator	Emission Designator
BW(MHz)	(99%OBW)QPSK	(99%OBW)16QAM
5	4M54G7D	4M53W7D
10	9M01G7D	9M01W7D
15	13M5G7D	13M52W7D
20	18M03G7D	17M97W7D
LTE Band 12	Emission Designator	Emission Designator
BW(MHz)	(99%OBW)QPSK	(99%OBW)16QAM
1.4	1M52G7D	1M42W7D
3	2M77G7D	2M69W7D
5	4M56G7D	4M53W7D
10	9M10G7D	8M98W7D
LTE Band 13	Emission Designator	Emission Designator
BW(MHz)	(99%OBW)QPSK	(99%OBW)16QAM
5	4M54G7D	4M51W7D
10	8M99G7D	9M01W7D



LTE Band 17	Emission Designator	Emission Designator
BW(MHz)	(99%OBW)QPSK	(99%OBW)16QAM
5	4M58G7D	4M54W7D
10	9M07G7D	9M02W7D
LTE Band 26 (Part 22)	Emission Designator	Emission Designator
BW(MHz)	(99%OBW)QPSK	(99%OBW)16QAM
1.4	1M09G7D	1M10W7D
3	2M69G7D	2M68W7D
5	4M55G7D	4M54W7D
10	9M03G7D	9M03W7D
15	13M49G7D	13M52W7D
LTE Band 26 (Part 90)	Emission Designator	Emission Designator
BW(MHz)	(99%OBW)QPSK	(99%OBW)16QAM
1.4	1M09G7D	1M09W7D
3	2M69G7D	2M69W7D
5	4M53G7D	4M53W7D
10	8M99G7D	9M0W7D
LTE Band 41	Emission Designator	Emission Designator
BW(MHz)	(99%OBW)QPSK	(99%OBW)16QAM
5	4M52G7D	4M53W7D
10	9M00G7D	9M01W7D
15	13M54G7D	13M53W7D
20	18M00G7D	17M98W7D
LTE Band 66	Emission Designator	Emission Designator
BW(MHz)	(99%OBW)QPSK	(99%OBW)16QAM
1.4	1M09G7D	1M09W7D
3	2M69G7D	2M68W7D
5	4M53G7D	4M54W7D
10	9M02G7D	9M02W7D
15	13M50G7D	13M47W7D
20	17M99G7D	18M02W7D



### 3 TEST CONFIGURATION OF EQUIPMENT UNDER TEST

Antenna port conducted and radiated test items were performed according to KDB 971168 D01 and ANSI C63.26 2015 Power Meas. License Digital Systems with maximum output power.

Radiated measurements were performed with rotating EUT in different three orthogonal test planes to find the maximum emission.

Radiated emissions were investigated as following frequency range:

1. 30 MHz to 10th harmonic for GSM850 and WCDMA Band V.
2. 30 MHz to 10th harmonic for WCDMA Band IV.
3. 30 MHz to 10th harmonic for GSM1900 and WCDMA Band II.

All modes and data rates and positions were investigated.

Test modes are chosen to be reported as the worst case configuration below:

BAND	TEST MODES	
	RADIATED TCS	CONDUCTED TCS
GPRS 850	GPRS/EDGE CLASS 12 LINK	GPRS/EDGE CLASS 12 LINK
GPRS 1900	GPRS/EDGE CLASS 12 LINK	GPRS/EDGE CLASS 12 LINK
WCDMA BAND V	RMC 12.2KBPS LINK	RMC 12.2KBPS LINK
WCDMA BAND II	RMC 12.2KBPS LINK	RMC 12.2KBPS LINK
WCDMA BAND IV	RMC 12.2KBPS LINK	RMC 12.2KBPS LINK



LTE:

ITEMS	Band	Bandwidth (MHz)						Modulation		RB #			Test Channel		
		1.4	3	5	10	15	20	QPSK	16QAM	1	Half	Full	L	M	H
Max. Output Power	2	v	v	v	v	v	v	v	v	v	v	v	v	v	v
	4	v	v	v	v	v	v	v	v	v	v	v	v	v	v
	5	v	v	v	v			v	v	v	v	v	v	v	v
	7			v	v	v	v	v	v	v	v	v	v	v	v
	12	v	v	v	v			v	v	v	v	v	v	v	v
	13			v	v			v	v	v	v	v		v	
	17			v	v			v	v	v	v	v	v	v	v
	26	v	v	v	v	v		v	v	v	v	v	v	v	v
	41			v	v	v	v	v	v	v	v	v	v	v	v
	66	v	v	v	v	v	v	v	v	v	v	v	v	v	v
Peak&Avera Ratio	2	v	v	v	v	v	v	v	v	v			v	v	v
	4	v	v	v	v	v	v	v	v	v			v	v	v
	5	v	v	v	v			v	v	v			v	v	v
	7			v	v	v	v	v	v	v			v	v	v
	12	v	v	v	v			v	v	v			v	v	v
	13			v	v			v	v	v				v	
	17			v	v			v	v	v			v	v	v
	26	v	v	v	v	v		v	v	v			v	v	v
	41			v	v	v	v	v	v	v			v	v	v
	66	v	v	v	v	v	v	v	v	v			v	v	v
26dB&99% Bandwidth	2	v	v	v	v	v	v	v	v			v	v	v	v
	4	v	v	v	v	v	v	v	v			v	v	v	v
	5	v	v	v	v			v	v			v	v	v	v
	7			v	v	v	v	v	v			v	v	v	v
	12	v	v	v	v			v	v			v	v	v	v
	13			v	v			v	v			v		v	
	17			v	v			v	v			v	v	v	v
	26	v	v	v	v	v		v	v			v	v	v	v
	41			v	v	v	v	v	v			v	v	v	v
	66	v	v	v	v	v	v	v	v			v	v	v	v
Conducted Band Edge	2	v	v	v	v	v	v	v	v			v	v		v
	4	v	v	v	v	v	v	v	v			v	v		v
	5	v	v	v	v			v	v			v	v		v
	7			v	v	v	v	v	v			v	v		v
	12	v	v	v	v			v	v			v	v		v
	13			v	v			v	v			v		v	
	17			v	v			v	v			v	v		v
	26	v	v	v	v	v		v	v			v	v		v
	41			v	v	v	v	v	v			v	v		v
	66	v	v	v	v	v	v	v	v			v	v		v



Conducted Spurious Emission	2	v	v	v	v	v	v	v	v	v	v	v	v	v	v
	4	v	v	v	v	v	v	v	v	v	v	v	v	v	v
	5	v	v	v	v			v	v	v		v	v	v	v
	7			v	v	v	v	v	v	v		v	v	v	v
	12	v	v	v	v			v	v	v		v	v	v	v
	13			v	v			v	v	v		v		v	
	17			v	v			v	v	v		v	v	v	v
	26	v	v	v	v	v		v	v	v		v	v	v	v
	41			v	v	v	v	v	v	v		v	v	v	v
	66	v	v	v	v	v	v	v	v	v		v	v	v	v
Frequency Stability	2				v			v				v		v	
	4				v			v				v		v	
	5				v			v				v		v	
	7				v			v				v		v	
	12				v			v				v		v	
	13				v			v				v		v	
	17				v			v				v		v	
	26				v			v				v		v	
	41				v			v				v		v	
	66				v			v				v		v	
E.R.P.& E.I.R.P.	2	v	v	v	v	v	v	v	v	v	v	v	v	v	v
	4	v	v	v	v	v	v	v	v	v	v	v	v	v	v
	5	v	v	v	v			v	v	v	v	v	v	v	v
	7			v	v	v	v	v	v	v	v	v	v	v	v
	12	v	v	v	v			v	v	v	v	v	v	v	v
	13			v	v			v	v	v	v	v		v	
	17			v	v			v	v	v	v	v	v	v	v
	26	v	v	v	v	v		v	v	v	v	v	v	v	v
	41			v	v	v	v	v	v	v	v	v	v	v	v
	66	v	v	v	v	v	v	v	v	v	v	v	v	v	v
Radiated Spurious Emission	2	v	v	v	v	v	v	v		v			v	v	v
	4	v	v	v	v	v	v	v		v			v	v	v
	5	v	v	v	v			v		v			v	v	v
	7			v	v	v	v	v		v			v	v	v
	12	v	v	v	v			v		v			v	v	v
	13			v	v			v		v				v	
	17			v	v			v		v			v	v	v
	26	v	v	v	v	v		v		v			v	v	v
	41			v	v	v	v	v		v			v	v	v
	66	v	v	v	v	v	v	v		v			v	v	v





4 MEASUREMENT INSTRUMENTS

RF Radiation Test Equipment					
Kind of Equipment	Manufacturer	Type No.	Serial No.	Last Calibration	Calibrated Until
Temperature & Humidity	SW-108	SuWei	N/A	2023.03.03	2024.03.02
Wireless Communications Test Set	R&S	CMW 500	117239	2023.03.01	2024.02.29
Pre-Amplifier(0.1M-3GHz)	EM	EM330	060665	2022.07.04	2023.07.03
Pre-Amplifier (1G-18GHz)	SKET	LNPA-01018G-45	SK2018080901	2022.09.29	2023.09.28
Positioning Controller	MF	MF-7802	MF-780208587	N/A	N/A
Signal Analyzer	R&S	FSV 40-N	101823	2022.09.29	2023.09.28
Switch Control Box	N/A	N/A	N/A	N/A	N/A
Filter Box	BALUN Technology	SU319E	BL-SZ1530051	N/A	N/A
Video Controller	SKET	FCS C-3	N/A	N/A	N/A
Bilog Antenna	TESEQ	CBL6111D	34678	2022.09.30	2024.09.29
Horn Antenna	SCHWARZBECK	BBHA 9120D	02014	2021.10.11	2023.10.10
Antenna Mast	MF	MFA-440H	N/A	N/A	N/A
Turn Table	MF	N/A	N/A	N/A	N/A
AC Power Source	APC	KDF-11010G	F214050035	N/A	N/A
DC Power Supply	Zhaoxin	RXN 605D	20R605D11010081	N/A	N/A
Test SW	EMC Test Software	15.2.0.339			
	EZ-EMC	Ver.STSLAB-03A1 RE			
RF Connected Test Equipment					
Kind of Equipment	Manufacturer	Type No.	Serial No.	Last Calibration	Calibrated Until
Temperature & Humidity	SW-108	SuWei	N/A	2023.03.03	2024.03.02
Wireless Communications Test Set	R&S	CMW 500	131428	2023.03.01	2024.02.29
Signal Analyzer	Agilent	N9020A	MY52440124	2023.03.01	2024.02.29
RF Automatic Test System	Maiwei	MW200-SFCB	N/A	N/A	N/A
Temperature & Humidity Test Chamber	Safety test	AG80L	171200018	2023.03.01	2024.02.29
Programmable Power Supply	Agilent	E3642A	MY40002025	2022.09.29	2023.09.28
Test SW	MTS 8200	2.0.0.0			



## 5 TEST ITEMS

### 5.1 CONDUCTED OUTPUT POWER&TRANSMITTER RADIATED POWER

#### TEST OVERVIEW

##### CONDUCTED OUTPUT POWER:

A system simulator was used to establish communication with the EUT. Its parameters were set to enforce EUT transmitting at the maximum power. The measured power in the radio frequency on the transmitter output terminals shall be reported.

##### TRANSMITTER RADIATED POWER (EIRP/ERP)

Determining ERP and/or EIRP from conducted RF output power measurements according to ANSI C63.26 2015 Section 5.2.5.5.

In many cases, RF output power limits are specified in terms of the ERP or the EIRP. Typically, ERP is specified when the operating frequency is less than or equal to 1 GHz and EIRP is specified when the operating frequency is greater than 1 GHz. Both are defined as the product of the power supplied to the antenna and its gain (relative to a dipole antenna in the case of ERP, and relative to an isotropic antenna in the case of EIRP); however, when working in decibels (i.e., logarithmic scale), the ERP and EIRP represent the sum of the transmit antenna gain (in dBd or dBi, respectively) and the conducted RF output power (expressed in dB relative to watts or milliwatts). The relevant equation for determining the maximum ERP or EIRP from the measured RF output power is given in Equation (1) as follows:

$$(1) \text{ ERP or EIRP} = P_{\text{Meas}} + GT$$

$$\text{ERP} = \text{EIRP} - 2.15$$

where

ERP or EIRP effective radiated power or equivalent isotropically radiated power, respectively (expressed in the same units as  $P_{\text{Meas}}$ , e.g., dBm or dBW)

$P_{\text{Meas}}$  measured transmitter output power or PSD, in dBm or dBW

GT gain of the transmitting antenna, in dBd (ERP) or dBi (EIRP)

For devices utilizing multiple antennas, see 6.4 for guidance with respect to determining the effective array transmit antenna gain term to be used in the above equation.

The following equations demonstrate the mathematical relationship between ERP and EIRP:

a)  $\text{ERP} = \text{EIRP} - 2.15$ , where ERP and EIRP are expressed in consistent units.

b)  $\text{EIRP} = \text{ERP} + 2.15$ , where ERP and EIRP are expressed in consistent units.

#### TEST PROCEDURES

1. The transmitter output port was connected to the system simulator.
2. Set eut at maximum power through the system simulator.
3. Select lowest, middle, and highest channels for each band and different modulation.
4. Measure and record the power level from the system simulator.

#### TEST SETUP



TEST RESULT

GSM 850							
Mode	Frequency (MHz)	Conduction AVG Power(dBm)	Ant Gain (dBi)	ERP (dBm)	ERP Limit (W)	ERP Limit (dBm)	Conclusion
GPRS (GMSK,1-Slot)	824.2	32.72	0.15	30.72	7.00	38.45	PASS
	836.6	32.49	0.15	30.49	7.00	38.45	PASS
	848.8	32.41	0.15	30.41	7.00	38.45	PASS
GPRS (GMSK,2-Slot)	824.2	32.08	0.15	30.08	7.00	38.45	PASS
	836.6	31.80	0.15	29.80	7.00	38.45	PASS
	848.8	31.69	0.15	29.69	7.00	38.45	PASS
GPRS (GMSK,3-Slot)	824.2	30.40	0.15	28.40	7.00	38.45	PASS
	836.6	30.08	0.15	28.08	7.00	38.45	PASS
	848.8	29.95	0.15	27.95	7.00	38.45	PASS
GPRS (GMSK,4-Slot)	824.2	29.30	0.15	27.30	7.00	38.45	PASS
	836.6	28.98	0.15	26.98	7.00	38.45	PASS
	848.8	28.82	0.15	26.82	7.00	38.45	PASS
EGPRS (8PSK,1-Slot)	824.2	27.00	0.15	25.00	7.00	38.45	PASS
	836.6	26.93	0.15	24.93	7.00	38.45	PASS
	848.8	26.92	0.15	24.92	7.00	38.45	PASS
EGPRS (8PSK,2-Slot)	824.2	25.76	0.15	23.76	7.00	38.45	PASS
	836.6	25.86	0.15	23.86	7.00	38.45	PASS
	848.8	25.86	0.15	23.86	7.00	38.45	PASS
EGPRS (8PSK,3-Slot)	824.2	24.19	0.15	22.19	7.00	38.45	PASS
	836.6	23.26	0.15	21.26	7.00	38.45	PASS
	848.8	23.79	0.15	21.79	7.00	38.45	PASS
EGPRS (8PSK,4-Slot)	824.2	22.76	0.15	20.76	7.00	38.45	PASS
	836.6	22.45	0.15	20.45	7.00	38.45	PASS
	848.8	22.50	0.15	20.50	7.00	38.45	PASS



PCS 1900							
Mode	Frequency (MHz)	Conduction AVG Power(dBm)	Ant Gain (dBi)	EIRP (dBm)	EIRP Limit (W)	EIRP Limit (dBm)	Conclusion
GPRS (GMSK,1-Slot)	1850.2	29.30	0.23	29.53	2.00	33.01	PASS
	1880.0	29.88	0.23	30.11	2.00	33.01	PASS
	1909.8	30.14	0.23	30.37	2.00	33.01	PASS
GPRS (GMSK,2-Slot)	1850.2	28.70	0.23	28.93	2.00	33.01	PASS
	1880.0	29.27	0.23	29.50	2.00	33.01	PASS
	1909.8	29.53	0.23	29.76	2.00	33.01	PASS
GPRS (GMSK,3-Slot)	1850.2	27.11	0.23	27.34	2.00	33.01	PASS
	1880.0	27.68	0.23	27.91	2.00	33.01	PASS
	1909.8	27.96	0.23	28.19	2.00	33.01	PASS
GPRS (GMSK,4-Slot)	1850.2	26.01	0.23	26.24	2.00	33.01	PASS
	1880.0	26.61	0.23	26.84	2.00	33.01	PASS
	1909.8	26.87	0.23	27.10	2.00	33.01	PASS
EGPRS (8PSK,1-Slot)	1850.2	25.45	0.23	25.68	2.00	33.01	PASS
	1880.0	26.58	0.23	26.81	2.00	33.01	PASS
	1909.8	26.68	0.23	26.91	2.00	33.01	PASS
EGPRS (8PSK,2-Slot)	1850.2	24.28	0.23	24.51	2.00	33.01	PASS
	1880.0	25.17	0.23	25.40	2.00	33.01	PASS
	1909.8	25.76	0.23	25.99	2.00	33.01	PASS
EGPRS (8PSK,3-Slot)	1850.2	22.63	0.23	22.86	2.00	33.01	PASS
	1880.0	22.70	0.23	22.93	2.00	33.01	PASS
	1909.8	23.43	0.23	23.66	2.00	33.01	PASS
EGPRS (8PSK,4-Slot)	1850.2	20.91	0.23	21.14	2.00	33.01	PASS
	1880.0	21.27	0.23	21.50	2.00	33.01	PASS
	1909.8	21.99	0.23	22.22	2.00	33.01	PASS



Radiated Power (EIRP) for WCDMA Band 2							
Mode	Frequency (MHz)	Conduction AVG Power(dBm)	Ant Gain (dBi)	EIRP (dBm)	EIRP Limit(W)	EIRP Limit (dBm)	Conclusion
WCDMA	1852.40	22.65	0.18	22.83	2.00	33.01	PASS
	1880.00	22.63	0.18	22.81	2.00	33.01	PASS
	1907.60	22.47	0.18	22.65	2.00	33.01	PASS
HSDPA Subtest 1	1852.40	21.64	0.18	21.82	2.00	33.01	PASS
	1880.00	21.23	0.18	21.41	2.00	33.01	PASS
	1907.60	19.90	0.18	20.08	2.00	33.01	PASS
HSDPA Subtest 2	1852.40	20.09	0.18	20.27	2.00	33.01	PASS
	1880.00	21.68	0.18	21.86	2.00	33.01	PASS
	1907.60	21.30	0.18	21.48	2.00	33.01	PASS
HSDPA Subtest 3	1852.40	20.04	0.18	20.22	2.00	33.01	PASS
	1880.00	20.47	0.18	20.65	2.00	33.01	PASS
	1907.60	21.50	0.18	21.68	2.00	33.01	PASS
HSDPA Subtest 4	1852.40	21.22	0.18	21.40	2.00	33.01	PASS
	1880.00	19.98	0.18	20.16	2.00	33.01	PASS
	1907.60	19.68	0.18	19.86	2.00	33.01	PASS
HSUPA Subtest 1	1852.40	20.48	0.18	20.66	2.00	33.01	PASS
	1880.00	21.50	0.18	21.68	2.00	33.01	PASS
	1907.60	19.57	0.18	19.75	2.00	33.01	PASS
HSUPA Subtest 2	1852.40	21.58	0.18	21.76	2.00	33.01	PASS
	1880.00	20.41	0.18	20.59	2.00	33.01	PASS
	1907.60	21.35	0.18	21.53	2.00	33.01	PASS
HSUPA Subtest 3	1852.40	21.41	0.18	21.59	2.00	33.01	PASS
	1880.00	20.52	0.18	20.70	2.00	33.01	PASS
	1907.60	21.61	0.18	21.79	2.00	33.01	PASS
HSUPA Subtest 4	1852.40	20.98	0.18	21.16	2.00	33.01	PASS
	1880.00	21.28	0.18	21.46	2.00	33.01	PASS
	1907.60	21.31	0.18	21.49	2.00	33.01	PASS
HSUPA Subtest 5	1852.40	20.05	0.18	20.23	2.00	33.01	PASS
	1880.00	21.44	0.18	21.62	2.00	33.01	PASS
	1907.60	20.88	0.18	21.06	2.00	33.01	PASS



Radiated Power (EIRP) for WCDMA Band 4							
Mode	Frequency (MHz)	Conduction AVG Power(dBm)	Ant Gain (dBi)	EIRP (dBm)	EIRP Limit(W)	EIRP Limit (dBm)	Conclusion
WCDMA	1712.40	21.78	0.31	22.09	1.00	30.00	PASS
	1740.00	21.54	0.31	21.85	1.00	30.00	PASS
	1752.60	21.67	0.31	21.98	1.00	30.00	PASS
HSDPA Subtest 1	1712.40	20.48	0.31	20.79	1.00	30.00	PASS
	1740.00	20.16	0.31	20.47	1.00	30.00	PASS
	1752.60	18.97	0.31	19.28	1.00	30.00	PASS
HSDPA Subtest 2	1712.40	18.85	0.31	19.16	1.00	30.00	PASS
	1740.00	20.28	0.31	20.59	1.00	30.00	PASS
	1752.60	19.68	0.31	19.99	1.00	30.00	PASS
HSDPA Subtest 3	1712.40	18.96	0.31	19.27	1.00	30.00	PASS
	1740.00	18.62	0.31	18.93	1.00	30.00	PASS
	1752.60	20.41	0.31	20.72	1.00	30.00	PASS
HSDPA Subtest 4	1712.40	19.74	0.31	20.05	1.00	30.00	PASS
	1740.00	18.57	0.31	18.88	1.00	30.00	PASS
	1752.60	19.09	0.31	19.40	1.00	30.00	PASS
HSUPA Subtest 1	1712.40	19.24	0.31	19.55	1.00	30.00	PASS
	1740.00	20.68	0.31	20.99	1.00	30.00	PASS
	1752.60	18.80	0.31	19.11	1.00	30.00	PASS
HSUPA Subtest 2	1712.40	20.68	0.31	20.99	1.00	30.00	PASS
	1740.00	18.99	0.31	19.30	1.00	30.00	PASS
	1752.60	20.27	0.31	20.58	1.00	30.00	PASS
HSUPA Subtest 3	1712.40	20.37	0.31	20.68	1.00	30.00	PASS
	1740.00	19.26	0.31	19.57	1.00	30.00	PASS
	1752.60	20.40	0.31	20.71	1.00	30.00	PASS
HSUPA Subtest 4	1712.40	19.73	0.31	20.04	1.00	30.00	PASS
	1740.00	20.39	0.31	20.70	1.00	30.00	PASS
	1752.60	20.58	0.31	20.89	1.00	30.00	PASS
HSUPA Subtest 5	1712.40	19.05	0.31	19.36	1.00	30.00	PASS
	1740.00	20.49	0.31	20.80	1.00	30.00	PASS
	1752.60	19.84	0.31	20.15	1.00	30.00	PASS





Radiated Power (ERP) for WCDMA Band 5							
Mode	Frequency (MHz)	Conduction AVG Power(dBm)	Ant Gain (dBi)	ERP (dBm)	ERP Limit(W)	ERP Limit (dBm)	Conclusion
WCDMA	826.40	23.52	0.15	21.52	7.00	38.45	PASS
	836.40	23.45	0.15	21.45	7.00	38.45	PASS
	846.60	23.40	0.15	21.40	7.00	38.45	PASS
HSDPA Subtest 1	826.40	22.40	0.15	20.40	7.00	38.45	PASS
	836.40	22.03	0.15	20.03	7.00	38.45	PASS
	846.60	20.95	0.15	18.95	7.00	38.45	PASS
HSDPA Subtest 2	826.40	20.85	0.15	18.85	7.00	38.45	PASS
	836.40	22.34	0.15	20.34	7.00	38.45	PASS
	846.60	21.86	0.15	19.86	7.00	38.45	PASS
HSDPA Subtest 3	826.40	20.83	0.15	18.83	7.00	38.45	PASS
	836.40	20.82	0.15	18.82	7.00	38.45	PASS
	846.60	22.22	0.15	20.22	7.00	38.45	PASS
HSDPA Subtest 4	826.40	21.60	0.15	19.60	7.00	38.45	PASS
	836.40	20.77	0.15	18.77	7.00	38.45	PASS
	846.60	20.54	0.15	18.54	7.00	38.45	PASS
HSUPA Subtest 1	826.40	21.78	0.15	19.78	7.00	38.45	PASS
	836.40	22.25	0.15	20.25	7.00	38.45	PASS
	846.60	20.40	0.15	18.40	7.00	38.45	PASS
HSUPA Subtest 2	826.40	22.38	0.15	20.38	7.00	38.45	PASS
	836.40	20.57	0.15	18.57	7.00	38.45	PASS
	846.60	21.97	0.15	19.97	7.00	38.45	PASS
HSUPA Subtest 3	826.40	22.23	0.15	20.23	7.00	38.45	PASS
	836.40	20.85	0.15	18.85	7.00	38.45	PASS
	846.60	22.28	0.15	20.28	7.00	38.45	PASS
HSUPA Subtest 4	826.40	21.88	0.15	19.88	7.00	38.45	PASS
	836.40	21.99	0.15	19.99	7.00	38.45	PASS
	846.60	22.07	0.15	20.07	7.00	38.45	PASS
HSUPA Subtest 5	826.40	20.74	0.15	18.74	7.00	38.45	PASS
	836.40	22.16	0.15	20.16	7.00	38.45	PASS
	846.60	21.75	0.15	19.75	7.00	38.45	PASS



Radiated Power (EIRP) for LTE Band 2 /1.4M										
BW (MHz)	UL Channel	RB Size	RB offset	Modulation	Conduction AVG Power(dBm)	Ant Gain (dBi)	EIRP (dBm)	EIRP Limit(W)	EIRP Limit(dBm)	Verdict
1.4	Lowest	1	0	QPSK	23.78	0.26	24.04	2.00	33.01	PASS
		1	2		23.94	0.26	24.20	2.00	33.01	PASS
		1	5		23.80	0.26	24.06	2.00	33.01	PASS
		3	0		23.63	0.26	23.89	2.00	33.01	PASS
		3	1		23.69	0.26	23.95	2.00	33.01	PASS
		3	2		23.65	0.26	23.91	2.00	33.01	PASS
		6	0	22.79	0.26	23.05	2.00	33.01	PASS	
		1	0	22.71	0.26	22.97	2.00	33.01	PASS	
		1	2	22.86	0.26	23.12	2.00	33.01	PASS	
		1	5	22.73	0.26	22.99	2.00	33.01	PASS	
		3	0	22.79	0.26	23.05	2.00	33.01	PASS	
		3	1	22.79	0.26	23.05	2.00	33.01	PASS	
	3	2	22.76	0.26	23.02	2.00	33.01	PASS		
	6	0	21.80	0.26	22.06	2.00	33.01	PASS		
	Middle	QPSK	1	0	23.78	0.26	24.04	2.00	33.01	PASS
			1	2	23.92	0.26	24.18	2.00	33.01	PASS
			1	5	23.76	0.26	24.02	2.00	33.01	PASS
			3	0	23.82	0.26	24.08	2.00	33.01	PASS
			3	1	23.82	0.26	24.08	2.00	33.01	PASS
			3	2	23.81	0.26	24.07	2.00	33.01	PASS
		6	0	22.83	0.26	23.09	2.00	33.01	PASS	
		16QAM	1	0	22.93	0.26	23.19	2.00	33.01	PASS
			1	2	23.05	0.26	23.31	2.00	33.01	PASS
			1	5	22.91	0.26	23.17	2.00	33.01	PASS
			3	0	23.02	0.26	23.28	2.00	33.01	PASS
			3	1	23.07	0.26	23.33	2.00	33.01	PASS
	3		2	23.01	0.26	23.27	2.00	33.01	PASS	
	6	0	21.93	0.26	22.19	2.00	33.01	PASS		
	Highest	QPSK	1	0	23.65	0.26	23.91	2.00	33.01	PASS
			1	2	23.73	0.26	23.99	2.00	33.01	PASS
			1	5	23.61	0.26	23.87	2.00	33.01	PASS
			3	0	23.59	0.26	23.85	2.00	33.01	PASS
			3	1	23.60	0.26	23.86	2.00	33.01	PASS
			3	2	23.57	0.26	23.83	2.00	33.01	PASS
		6	0	22.63	0.26	22.89	2.00	33.01	PASS	
		16QAM	1	0	22.40	0.26	22.66	2.00	33.01	PASS
1			2	22.57	0.26	22.83	2.00	33.01	PASS	
1			5	22.39	0.26	22.65	2.00	33.01	PASS	
3			0	22.70	0.26	22.96	2.00	33.01	PASS	
3			1	22.72	0.26	22.98	2.00	33.01	PASS	
3	2		22.72	0.26	22.98	2.00	33.01	PASS		
6	0	21.72	0.26	21.98	2.00	33.01	PASS			





Radiated Power (EIRP) for LTE Band 2 /3M										
BW (MHz)	UL Channel	RB Size	RB offset	Modulation	Conduction AVG Power(dBm)	Ant Gain (dBi)	EIRP (dBm)	EIRP Limit(W)	EIRP Limit(dBm)	Verdict
3	Lowest	1	0	QPSK	23.72	0.26	23.98	2.00	33.01	PASS
		1	7		23.94	0.26	24.20	2.00	33.01	PASS
		1	14		23.74	0.26	24.00	2.00	33.01	PASS
		8	0		22.73	0.26	22.99	2.00	33.01	PASS
		8	4		22.76	0.26	23.02	2.00	33.01	PASS
		8	7		22.76	0.26	23.02	2.00	33.01	PASS
		15	0		22.66	0.26	22.92	2.00	33.01	PASS
		1	0	16QAM	22.81	0.26	23.07	2.00	33.01	PASS
		1	7		23.15	0.26	23.41	2.00	33.01	PASS
		1	14		22.80	0.26	23.06	2.00	33.01	PASS
		8	0		21.63	0.26	21.89	2.00	33.01	PASS
		8	4		21.66	0.26	21.92	2.00	33.01	PASS
		8	7		21.65	0.26	21.91	2.00	33.01	PASS
		15	0		21.56	0.26	21.82	2.00	33.01	PASS
		Middle	QPSK	1	0	23.85	0.26	24.11	2.00	33.01
	1			7	24.17	0.26	24.43	2.00	33.01	PASS
	1			14	23.90	0.26	24.16	2.00	33.01	PASS
	8			0	22.84	0.26	23.10	2.00	33.01	PASS
	8			4	22.85	0.26	23.11	2.00	33.01	PASS
	8			7	22.81	0.26	23.07	2.00	33.01	PASS
	15			0	22.79	0.26	23.05	2.00	33.01	PASS
	16QAM		1	0	22.65	0.26	22.91	2.00	33.01	PASS
			1	7	22.91	0.26	23.17	2.00	33.01	PASS
			1	14	22.59	0.26	22.85	2.00	33.01	PASS
			8	0	21.74	0.26	22.00	2.00	33.01	PASS
			8	4	21.74	0.26	22.00	2.00	33.01	PASS
			8	7	21.78	0.26	22.04	2.00	33.01	PASS
			15	0	21.81	0.26	22.07	2.00	33.01	PASS
			Highest	QPSK	1	0	23.59	0.26	23.85	2.00
	1	7			23.84	0.26	24.10	2.00	33.01	PASS
	1	14			23.53	0.26	23.79	2.00	33.01	PASS
	8	0			22.62	0.26	22.88	2.00	33.01	PASS
	8	4			22.63	0.26	22.89	2.00	33.01	PASS
	8	7			22.62	0.26	22.88	2.00	33.01	PASS
	15	0			22.57	0.26	22.83	2.00	33.01	PASS
	16QAM	1		0	23.02	0.26	23.28	2.00	33.01	PASS
1		7		23.06	0.26	23.32	2.00	33.01	PASS	
1		14		22.90	0.26	23.16	2.00	33.01	PASS	
8		0		21.56	0.26	21.82	2.00	33.01	PASS	
8		4		21.60	0.26	21.86	2.00	33.01	PASS	
8		7		21.54	0.26	21.80	2.00	33.01	PASS	
15		0		21.59	0.26	21.85	2.00	33.01	PASS	



Radiated Power (EIRP) for LTE Band 2 /5M										
BW (MHz)	UL Channel	RB Size	RB offset	Modulation	Conduction AVG Power(dBm)	Ant Gain (dBi)	EIRP (dBm)	EIRP Limit(W)	EIRP Limit(dBm)	Verdict
5	Lowest	1	0	QPSK	23.60	0.26	23.86	2.00	33.01	PASS
		1	12		24.02	0.26	24.28	2.00	33.01	PASS
		1	24		23.61	0.26	23.87	2.00	33.01	PASS
		12	0		22.59	0.26	22.85	2.00	33.01	PASS
		12	6		22.74	0.26	23.00	2.00	33.01	PASS
		12	11		22.63	0.26	22.89	2.00	33.01	PASS
		25	0		22.61	0.26	22.87	2.00	33.01	PASS
		1	0	16QAM	22.81	0.26	23.07	2.00	33.01	PASS
		1	12		23.20	0.26	23.46	2.00	33.01	PASS
		1	24		22.85	0.26	23.11	2.00	33.01	PASS
		12	0		21.57	0.26	21.83	2.00	33.01	PASS
		12	6		21.69	0.26	21.95	2.00	33.01	PASS
		12	11		21.63	0.26	21.89	2.00	33.01	PASS
		25	0		21.51	0.26	21.77	2.00	33.01	PASS
	Middle	QPSK	1	0	23.74	0.26	24.00	2.00	33.01	PASS
			1	12	24.06	0.26	24.32	2.00	33.01	PASS
			1	24	23.71	0.26	23.97	2.00	33.01	PASS
			12	0	22.77	0.26	23.03	2.00	33.01	PASS
			12	6	22.82	0.26	23.08	2.00	33.01	PASS
			12	11	22.79	0.26	23.05	2.00	33.01	PASS
			25	0	22.79	0.26	23.05	2.00	33.01	PASS
		16QAM	1	0	23.21	0.26	23.47	2.00	33.01	PASS
			1	12	23.52	0.26	23.78	2.00	33.01	PASS
			1	24	23.18	0.26	23.44	2.00	33.01	PASS
			12	0	21.76	0.26	22.02	2.00	33.01	PASS
			12	6	21.83	0.26	22.09	2.00	33.01	PASS
			12	11	21.76	0.26	22.02	2.00	33.01	PASS
			25	0	21.72	0.26	21.98	2.00	33.01	PASS
	Highest	QPSK	1	0	23.60	0.26	23.86	2.00	33.01	PASS
			1	12	23.90	0.26	24.16	2.00	33.01	PASS
1			24	23.55	0.26	23.81	2.00	33.01	PASS	
12			0	22.57	0.26	22.83	2.00	33.01	PASS	
12			6	22.61	0.26	22.87	2.00	33.01	PASS	
12			11	22.54	0.26	22.80	2.00	33.01	PASS	
25			0	22.60	0.26	22.86	2.00	33.01	PASS	
16QAM		1	0	22.85	0.26	23.11	2.00	33.01	PASS	
		1	12	23.17	0.26	23.43	2.00	33.01	PASS	
		1	24	22.79	0.26	23.05	2.00	33.01	PASS	
		12	0	21.53	0.26	21.79	2.00	33.01	PASS	
		12	6	21.57	0.26	21.83	2.00	33.01	PASS	
		12	11	21.46	0.26	21.72	2.00	33.01	PASS	
		25	0	21.55	0.26	21.81	2.00	33.01	PASS	



Radiated Power (EIRP) for LTE Band 2 /10M										
BW (MHz)	UL Channel	RB Size	RB offset	Modulation	Conduction AVG Power(dBm)	Ant Gain (dBi)	EIRP (dBm)	EIRP Limit(W)	EIRP Limit(dBm)	Verdict
10	Lowest	1	0	QPSK	23.69	0.26	23.95	2.00	33.01	PASS
		1	24		23.86	0.26	24.12	2.00	33.01	PASS
		1	49		23.81	0.26	24.07	2.00	33.01	PASS
		25	0		22.71	0.26	22.97	2.00	33.01	PASS
		25	12		22.81	0.26	23.07	2.00	33.01	PASS
		25	24		22.77	0.26	23.03	2.00	33.01	PASS
		50	0		22.70	0.26	22.96	2.00	33.01	PASS
		1	0	16QAM	22.97	0.26	23.23	2.00	33.01	PASS
		1	24		23.16	0.26	23.42	2.00	33.01	PASS
		1	49		23.11	0.26	23.37	2.00	33.01	PASS
		25	0		21.60	0.26	21.86	2.00	33.01	PASS
		25	12		21.74	0.26	22.00	2.00	33.01	PASS
		25	24		21.67	0.26	21.93	2.00	33.01	PASS
		50	0		21.64	0.26	21.90	2.00	33.01	PASS
	1	0	QPSK	23.85	0.26	24.11	2.00	33.01	PASS	
	1	24		23.94	0.26	24.20	2.00	33.01	PASS	
	1	49		23.75	0.26	24.01	2.00	33.01	PASS	
	25	0		22.85	0.26	23.11	2.00	33.01	PASS	
	25	12		22.84	0.26	23.10	2.00	33.01	PASS	
	25	24		22.85	0.26	23.11	2.00	33.01	PASS	
	50	0		22.87	0.26	23.13	2.00	33.01	PASS	
	1	0	16QAM	22.92	0.26	23.18	2.00	33.01	PASS	
	1	24		23.08	0.26	23.34	2.00	33.01	PASS	
	1	49		22.86	0.26	23.12	2.00	33.01	PASS	
	25	0		21.78	0.26	22.04	2.00	33.01	PASS	
	25	12		21.81	0.26	22.07	2.00	33.01	PASS	
	25	24		21.77	0.26	22.03	2.00	33.01	PASS	
	50	0		21.83	0.26	22.09	2.00	33.01	PASS	
	1	0	QPSK	23.78	0.26	24.04	2.00	33.01	PASS	
	1	24		23.85	0.26	24.11	2.00	33.01	PASS	
	1	49		23.67	0.26	23.93	2.00	33.01	PASS	
	25	0		22.68	0.26	22.94	2.00	33.01	PASS	
	25	12		22.66	0.26	22.92	2.00	33.01	PASS	
	25	24		22.67	0.26	22.93	2.00	33.01	PASS	
	50	0		22.68	0.26	22.94	2.00	33.01	PASS	
	1	0	16QAM	22.54	0.26	22.80	2.00	33.01	PASS	
1	24	22.65		0.26	22.91	2.00	33.01	PASS		
1	49	22.42		0.26	22.68	2.00	33.01	PASS		
25	0	21.67		0.26	21.93	2.00	33.01	PASS		
25	12	21.64		0.26	21.90	2.00	33.01	PASS		
25	24	21.63		0.26	21.89	2.00	33.01	PASS		
50	0	21.61		0.26	21.87	2.00	33.01	PASS		



Radiated Power (EIRP) for LTE Band 2 /15M										
BW (MHz)	UL Channel	RB Size	RB offset	Modulation	Conduction AVG Power(dBm)	Ant Gain (dBi)	EIRP (dBm)	EIRP Limit(W)	EIRP Limit(dBm)	Verdict
15	Lowest	1	0	QPSK	23.75	0.26	24.01	2.00	33.01	PASS
		1	37		24.11	0.26	24.37	2.00	33.01	PASS
		1	74		23.90	0.26	24.16	2.00	33.01	PASS
		36	0		22.80	0.26	23.06	2.00	33.01	PASS
		36	18		22.83	0.26	23.09	2.00	33.01	PASS
		36	39		22.80	0.26	23.06	2.00	33.01	PASS
		75	0		22.81	0.26	23.07	2.00	33.01	PASS
		1	0	16QAM	22.64	0.26	22.90	2.00	33.01	PASS
		1	37		23.12	0.26	23.38	2.00	33.01	PASS
		1	74		22.85	0.26	23.11	2.00	33.01	PASS
		36	0		21.70	0.26	21.96	2.00	33.01	PASS
		36	18		21.79	0.26	22.05	2.00	33.01	PASS
		36	39		21.75	0.26	22.01	2.00	33.01	PASS
		75	0		21.75	0.26	22.01	2.00	33.01	PASS
	Middle	QPSK	1	0	23.76	0.26	24.02	2.00	33.01	PASS
			1	37	23.97	0.26	24.23	2.00	33.01	PASS
			1	74	23.63	0.26	23.89	2.00	33.01	PASS
			36	0	22.87	0.26	23.13	2.00	33.01	PASS
			36	18	22.88	0.26	23.14	2.00	33.01	PASS
			36	39	22.84	0.26	23.10	2.00	33.01	PASS
			75	0	22.87	0.26	23.13	2.00	33.01	PASS
		16QAM	1	0	23.14	0.26	23.40	2.00	33.01	PASS
			1	37	23.39	0.26	23.65	2.00	33.01	PASS
			1	74	22.99	0.26	23.25	2.00	33.01	PASS
			36	0	21.88	0.26	22.14	2.00	33.01	PASS
			36	18	21.86	0.26	22.12	2.00	33.01	PASS
			36	39	21.80	0.26	22.06	2.00	33.01	PASS
			75	0	21.78	0.26	22.04	2.00	33.01	PASS
	Highest	QPSK	1	0	23.67	0.26	23.93	2.00	33.01	PASS
			1	37	23.97	0.26	24.23	2.00	33.01	PASS
			1	74	23.44	0.26	23.70	2.00	33.01	PASS
			36	0	22.74	0.26	23.00	2.00	33.01	PASS
			36	18	22.71	0.26	22.97	2.00	33.01	PASS
			36	39	22.66	0.26	22.92	2.00	33.01	PASS
			75	0	22.73	0.26	22.99	2.00	33.01	PASS
		16QAM	1	0	22.78	0.26	23.04	2.00	33.01	PASS
1			37	23.14	0.26	23.40	2.00	33.01	PASS	
1			74	22.51	0.26	22.77	2.00	33.01	PASS	
36			0	21.82	0.26	22.08	2.00	33.01	PASS	
36			18	21.74	0.26	22.00	2.00	33.01	PASS	
36			39	21.66	0.26	21.92	2.00	33.01	PASS	
75			0	21.65	0.26	21.91	2.00	33.01	PASS	



Radiated Power (EIRP) for LTE Band 2 /20M										
BW (MHz)	UL Channel	RB Size	RB offset	Modulation	Conduction AVG Power(dBm)	Ant Gain (dBi)	EIRP (dBm)	EIRP Limit(W)	EIRP Limit(dBm)	Verdict
20	Lowest	1	0	QPSK	23.49	0.26	23.75	2.00	33.01	PASS
		1	49		23.95	0.26	24.21	2.00	33.01	PASS
		1	99		23.56	0.26	23.82	2.00	33.01	PASS
		50	0		22.78	0.26	23.04	2.00	33.01	PASS
		50	24		22.83	0.26	23.09	2.00	33.01	PASS
		50	49		22.78	0.26	23.04	2.00	33.01	PASS
		100	0		22.81	0.26	23.07	2.00	33.01	PASS
		1	0	16QAM	22.63	0.26	22.89	2.00	33.01	PASS
		1	49		23.18	0.26	23.44	2.00	33.01	PASS
		1	99		22.90	0.26	23.16	2.00	33.01	PASS
		50	0		21.78	0.26	22.04	2.00	33.01	PASS
		50	24		21.84	0.26	22.10	2.00	33.01	PASS
		50	49		21.77	0.26	22.03	2.00	33.01	PASS
		100	0		21.80	0.26	22.06	2.00	33.01	PASS
	1	0	QPSK	23.71	0.26	23.97	2.00	33.01	PASS	
	1	49		24.19	0.26	24.45	2.00	33.01	PASS	
	1	99		23.58	0.26	23.84	2.00	33.01	PASS	
	50	0		22.85	0.26	23.11	2.00	33.01	PASS	
	50	24		22.83	0.26	23.09	2.00	33.01	PASS	
	50	49		22.74	0.26	23.00	2.00	33.01	PASS	
	100	0		22.78	0.26	23.04	2.00	33.01	PASS	
	1	0	16QAM	22.90	0.26	23.16	2.00	33.01	PASS	
	1	49		23.14	0.26	23.40	2.00	33.01	PASS	
	1	99		22.70	0.26	22.96	2.00	33.01	PASS	
	50	0		21.75	0.26	22.01	2.00	33.01	PASS	
	50	24		21.73	0.26	21.99	2.00	33.01	PASS	
	50	49		21.69	0.26	21.95	2.00	33.01	PASS	
	100	0		21.71	0.26	21.97	2.00	33.01	PASS	
	1	0	QPSK	23.50	0.26	23.76	2.00	33.01	PASS	
	1	49		23.86	0.26	24.12	2.00	33.01	PASS	
	1	99		23.38	0.26	23.64	2.00	33.01	PASS	
	50	0		22.88	0.26	23.14	2.00	33.01	PASS	
	50	24		22.75	0.26	23.01	2.00	33.01	PASS	
	50	49		22.68	0.26	22.94	2.00	33.01	PASS	
	100	0		22.75	0.26	23.01	2.00	33.01	PASS	
	1	0	16QAM	22.72	0.26	22.98	2.00	33.01	PASS	
1	49	23.08		0.26	23.34	2.00	33.01	PASS		
1	99	22.58		0.26	22.84	2.00	33.01	PASS		
50	0	21.82		0.26	22.08	2.00	33.01	PASS		
50	24	21.73		0.26	21.99	2.00	33.01	PASS		
50	49	21.72		0.26	21.98	2.00	33.01	PASS		
100	0	21.70		0.26	21.96	2.00	33.01	PASS		





Radiated Power (EIRP) for LTE Band 4 /1.4M										
BW (MHz)	UL Channel	RB Size	RB offset	Modulation	Conduction AVG Power(dBm)	Ant Gain (dBi)	EIRP (dBm)	EIRP Limit(W)	EIRP Limit(dBm)	Verdict
1.4	Lowest	1	0	QPSK	23.08	0.23	23.31	1.00	30.00	PASS
		1	2		23.25	0.23	23.48	1.00	30.00	PASS
		1	5		23.12	0.23	23.35	1.00	30.00	PASS
		3	0		23.17	0.23	23.40	1.00	30.00	PASS
		3	1		23.17	0.23	23.40	1.00	30.00	PASS
		3	2		23.18	0.23	23.41	1.00	30.00	PASS
		6	0		22.10	0.23	22.33	1.00	30.00	PASS
		1	0	16QAM	22.23	0.23	22.46	1.00	30.00	PASS
		1	2		22.38	0.23	22.61	1.00	30.00	PASS
		1	5		22.25	0.23	22.48	1.00	30.00	PASS
		3	0		22.37	0.23	22.60	1.00	30.00	PASS
		3	1		22.38	0.23	22.61	1.00	30.00	PASS
		3	2		22.41	0.23	22.64	1.00	30.00	PASS
		6	0		21.22	0.23	21.45	1.00	30.00	PASS
	Middle	QPSK	1	0	22.91	0.23	23.14	1.00	30.00	PASS
			1	2	23.08	0.23	23.31	1.00	30.00	PASS
			1	5	22.87	0.23	23.10	1.00	30.00	PASS
			3	0	22.83	0.23	23.06	1.00	30.00	PASS
			3	1	22.83	0.23	23.06	1.00	30.00	PASS
			3	2	22.83	0.23	23.06	1.00	30.00	PASS
			6	0	21.88	0.23	22.11	1.00	30.00	PASS
		16QAM	1	0	21.54	0.23	21.77	1.00	30.00	PASS
			1	2	21.75	0.23	21.98	1.00	30.00	PASS
			1	5	21.54	0.23	21.77	1.00	30.00	PASS
			3	0	21.91	0.23	22.14	1.00	30.00	PASS
			3	1	21.90	0.23	22.13	1.00	30.00	PASS
			3	2	21.94	0.23	22.17	1.00	30.00	PASS
			6	0	20.93	0.23	21.16	1.00	30.00	PASS
	Highest	QPSK	1	0	23.00	0.23	23.23	1.00	30.00	PASS
			1	2	23.15	0.23	23.38	1.00	30.00	PASS
			1	5	22.96	0.23	23.19	1.00	30.00	PASS
			3	0	22.91	0.23	23.14	1.00	30.00	PASS
			3	1	22.96	0.23	23.19	1.00	30.00	PASS
			3	2	22.96	0.23	23.19	1.00	30.00	PASS
			6	0	21.97	0.23	22.20	1.00	30.00	PASS
		16QAM	1	0	22.02	0.23	22.25	1.00	30.00	PASS
1			2	22.19	0.23	22.42	1.00	30.00	PASS	
1			5	22.11	0.23	22.34	1.00	30.00	PASS	
3			0	22.13	0.23	22.36	1.00	30.00	PASS	
3			1	22.14	0.23	22.37	1.00	30.00	PASS	
3			2	22.13	0.23	22.36	1.00	30.00	PASS	
6			0	21.09	0.23	21.32	1.00	30.00	PASS	



Radiated Power (EIRP) for LTE Band 4 /3M										
BW (MHz)	UL Channel	RB Size	RB offset	Modulation	Conduction AVG Power(dBm)	Ant Gain (dBi)	EIRP (dBm)	EIRP Limit(W)	EIRP Limit(dBm)	Verdict
3	Lowest	1	0	QPSK	23.13	0.23	23.36	1.00	30.00	PASS
		1	7		23.40	0.23	23.63	1.00	30.00	PASS
		1	14		23.17	0.23	23.40	1.00	30.00	PASS
		8	0		22.13	0.23	22.36	1.00	30.00	PASS
		8	4		22.16	0.23	22.39	1.00	30.00	PASS
		8	7		22.17	0.23	22.40	1.00	30.00	PASS
		15	0		22.14	0.23	22.37	1.00	30.00	PASS
		1	0	16QAM	22.53	0.23	22.76	1.00	30.00	PASS
		1	7		22.78	0.23	23.01	1.00	30.00	PASS
		1	14		22.57	0.23	22.80	1.00	30.00	PASS
		8	0		21.12	0.23	21.35	1.00	30.00	PASS
		8	4		21.14	0.23	21.37	1.00	30.00	PASS
		8	7		21.19	0.23	21.42	1.00	30.00	PASS
		15	0		21.15	0.23	21.38	1.00	30.00	PASS
		Middle	QPSK	1	0	22.87	0.23	23.10	1.00	30.00
	1			7	23.23	0.23	23.46	1.00	30.00	PASS
	1			14	22.84	0.23	23.07	1.00	30.00	PASS
	8			0	21.88	0.23	22.11	1.00	30.00	PASS
	8			4	21.92	0.23	22.15	1.00	30.00	PASS
	8			7	21.89	0.23	22.12	1.00	30.00	PASS
	15			0	21.80	0.23	22.03	1.00	30.00	PASS
	16QAM		1	0	21.95	0.23	22.18	1.00	30.00	PASS
			1	7	22.18	0.23	22.41	1.00	30.00	PASS
			1	14	21.90	0.23	22.13	1.00	30.00	PASS
			8	0	20.79	0.23	21.02	1.00	30.00	PASS
			8	4	20.82	0.23	21.05	1.00	30.00	PASS
			8	7	20.79	0.23	21.02	1.00	30.00	PASS
			15	0	20.72	0.23	20.95	1.00	30.00	PASS
			Highest	QPSK	1	0	23.03	0.23	23.26	1.00
	1	7			23.37	0.23	23.60	1.00	30.00	PASS
	1	14			23.03	0.23	23.26	1.00	30.00	PASS
	8	0			21.97	0.23	22.20	1.00	30.00	PASS
	8	4			21.99	0.23	22.22	1.00	30.00	PASS
	8	7			21.98	0.23	22.21	1.00	30.00	PASS
	15	0			21.93	0.23	22.16	1.00	30.00	PASS
	16QAM	1		0	21.79	0.23	22.02	1.00	30.00	PASS
1		7		22.08	0.23	22.31	1.00	30.00	PASS	
1		14		21.79	0.23	22.02	1.00	30.00	PASS	
8		0		20.92	0.23	21.15	1.00	30.00	PASS	
8		4		20.96	0.23	21.19	1.00	30.00	PASS	
8		7		20.93	0.23	21.16	1.00	30.00	PASS	
15		0		20.99	0.23	21.22	1.00	30.00	PASS	





Radiated Power (EIRP) for LTE Band 4 /5M										
BW (MHz)	UL Channel	RB Size	RB offset	Modulation	Conduction AVG Power(dBm)	Ant Gain (dBi)	EIRP (dBm)	EIRP Limit(W)	EIRP Limit(dBm)	Verdict
5	Lowest	1	0	QPSK	23.04	0.23	23.27	1.00	30.00	PASS
		1	12		23.52	0.23	23.75	1.00	30.00	PASS
		1	24		23.11	0.23	23.34	1.00	30.00	PASS
		12	0		22.12	0.23	22.35	1.00	30.00	PASS
		12	6		22.18	0.23	22.41	1.00	30.00	PASS
		12	11		22.22	0.23	22.45	1.00	30.00	PASS
		25	0		22.19	0.23	22.42	1.00	30.00	PASS
		1	0	16QAM	22.53	0.23	22.76	1.00	30.00	PASS
		1	12		22.97	0.23	23.20	1.00	30.00	PASS
		1	24		22.63	0.23	22.86	1.00	30.00	PASS
		12	0		21.12	0.23	21.35	1.00	30.00	PASS
		12	6		21.20	0.23	21.43	1.00	30.00	PASS
		12	11		21.25	0.23	21.48	1.00	30.00	PASS
		25	0		21.14	0.23	21.37	1.00	30.00	PASS
		Middle	QPSK	1	0	22.87	0.23	23.10	1.00	30.00
	1			12	23.23	0.23	23.46	1.00	30.00	PASS
	1			24	22.84	0.23	23.07	1.00	30.00	PASS
	12			0	21.71	0.23	21.94	1.00	30.00	PASS
	12			6	21.80	0.23	22.03	1.00	30.00	PASS
	12			11	21.74	0.23	21.97	1.00	30.00	PASS
	25			0	21.76	0.23	21.99	1.00	30.00	PASS
	16QAM		1	0	22.06	0.23	22.29	1.00	30.00	PASS
			1	12	22.31	0.23	22.54	1.00	30.00	PASS
			1	24	21.95	0.23	22.18	1.00	30.00	PASS
			12	0	20.75	0.23	20.98	1.00	30.00	PASS
			12	6	20.76	0.23	20.99	1.00	30.00	PASS
			12	11	20.71	0.23	20.94	1.00	30.00	PASS
			25	0	20.75	0.23	20.98	1.00	30.00	PASS
			Highest	QPSK	1	0	22.85	0.23	23.08	1.00
	1	12			23.28	0.23	23.51	1.00	30.00	PASS
	1	24			22.86	0.23	23.09	1.00	30.00	PASS
	12	0			21.91	0.23	22.14	1.00	30.00	PASS
	12	6			21.99	0.23	22.22	1.00	30.00	PASS
	12	11			21.92	0.23	22.15	1.00	30.00	PASS
	25	0			21.93	0.23	22.16	1.00	30.00	PASS
	16QAM	1		0	22.14	0.23	22.37	1.00	30.00	PASS
1		12		22.51	0.23	22.74	1.00	30.00	PASS	
1		24		22.18	0.23	22.41	1.00	30.00	PASS	
12		0		20.92	0.23	21.15	1.00	30.00	PASS	
12		6		21.04	0.23	21.27	1.00	30.00	PASS	
12		11		20.93	0.23	21.16	1.00	30.00	PASS	
25		0		20.89	0.23	21.12	1.00	30.00	PASS	



Radiated Power (EIRP) for LTE Band 4 /10M										
BW (MHz)	UL Channel	RB Size	RB offset	Modulation	Conduction AVG Power(dBm)	Ant Gain (dBi)	EIRP (dBm)	EIRP Limit(W)	EIRP Limit(dBm)	Verdict
10	Lowest	1	0	QPSK	23.12	0.23	23.35	1.00	30.00	PASS
		1	24		23.28	0.23	23.51	1.00	30.00	PASS
		1	49		23.09	0.23	23.32	1.00	30.00	PASS
		25	0		22.18	0.23	22.41	1.00	30.00	PASS
		25	12		22.25	0.23	22.48	1.00	30.00	PASS
		25	24		22.31	0.23	22.54	1.00	30.00	PASS
		50	0		22.27	0.23	22.50	1.00	30.00	PASS
		1	0	16QAM	22.48	0.23	22.71	1.00	30.00	PASS
		1	24		22.69	0.23	22.92	1.00	30.00	PASS
		1	49		22.48	0.23	22.71	1.00	30.00	PASS
		25	0		21.18	0.23	21.41	1.00	30.00	PASS
		25	12		21.23	0.23	21.46	1.00	30.00	PASS
		25	24		21.30	0.23	21.53	1.00	30.00	PASS
		50	0		21.28	0.23	21.51	1.00	30.00	PASS
	Middle	1	0	QPSK	22.94	0.23	23.17	1.00	30.00	PASS
		1	24		23.09	0.23	23.32	1.00	30.00	PASS
		1	49		22.84	0.23	23.07	1.00	30.00	PASS
		25	0		21.86	0.23	22.09	1.00	30.00	PASS
		25	12		21.82	0.23	22.05	1.00	30.00	PASS
		25	24		21.85	0.23	22.08	1.00	30.00	PASS
		50	0		21.80	0.23	22.03	1.00	30.00	PASS
		1	0	16QAM	22.00	0.23	22.23	1.00	30.00	PASS
		1	24		22.04	0.23	22.27	1.00	30.00	PASS
		1	49		21.86	0.23	22.09	1.00	30.00	PASS
		25	0		20.82	0.23	21.05	1.00	30.00	PASS
		25	12		20.82	0.23	21.05	1.00	30.00	PASS
		25	24		20.77	0.23	21.00	1.00	30.00	PASS
		50	0		20.79	0.23	21.02	1.00	30.00	PASS
	Highest	1	0	QPSK	23.05	0.23	23.28	1.00	30.00	PASS
		1	24		23.18	0.23	23.41	1.00	30.00	PASS
		1	49		23.04	0.23	23.27	1.00	30.00	PASS
		25	0		21.98	0.23	22.21	1.00	30.00	PASS
		25	12		21.97	0.23	22.20	1.00	30.00	PASS
		25	24		21.96	0.23	22.19	1.00	30.00	PASS
		50	0		21.96	0.23	22.19	1.00	30.00	PASS
		1	0	16QAM	21.75	0.23	21.98	1.00	30.00	PASS
1		24	21.92		0.23	22.15	1.00	30.00	PASS	
1		49	21.80		0.23	22.03	1.00	30.00	PASS	
25		0	20.93		0.23	21.16	1.00	30.00	PASS	
25		12	20.97		0.23	21.20	1.00	30.00	PASS	
25		24	20.93		0.23	21.16	1.00	30.00	PASS	
50		0	20.96		0.23	21.19	1.00	30.00	PASS	



Radiated Power (EIRP) for LTE Band 4 /15M										
BW (MHz)	UL Channel	RB Size	RB offset	Modulation	Conduction AVG Power(dBm)	Ant Gain (dBi)	EIRP (dBm)	EIRP Limit(W)	EIRP Limit(dBm)	Verdict
15	Lowest	1	0	QPSK	23.11	0.23	23.34	1.00	30.00	PASS
		1	37		23.40	0.23	23.63	1.00	30.00	PASS
		1	74		22.98	0.23	23.21	1.00	30.00	PASS
		36	0		22.22	0.23	22.45	1.00	30.00	PASS
		36	18		22.29	0.23	22.52	1.00	30.00	PASS
		36	39		22.26	0.23	22.49	1.00	30.00	PASS
		75	0		22.31	0.23	22.54	1.00	30.00	PASS
		1	0	16QAM	22.48	0.23	22.71	1.00	30.00	PASS
		1	37		22.77	0.23	23.00	1.00	30.00	PASS
		1	74		22.32	0.23	22.55	1.00	30.00	PASS
		36	0		21.22	0.23	21.45	1.00	30.00	PASS
		36	18		21.31	0.23	21.54	1.00	30.00	PASS
		36	39		21.28	0.23	21.51	1.00	30.00	PASS
		75	0		21.26	0.23	21.49	1.00	30.00	PASS
	Middle	QPSK	1	0	22.93	0.23	23.16	1.00	30.00	PASS
			1	37	23.10	0.23	23.33	1.00	30.00	PASS
			1	74	22.81	0.23	23.04	1.00	30.00	PASS
			36	0	21.92	0.23	22.15	1.00	30.00	PASS
			36	18	21.91	0.23	22.14	1.00	30.00	PASS
			36	39	21.90	0.23	22.13	1.00	30.00	PASS
			75	0	21.89	0.23	22.12	1.00	30.00	PASS
		16QAM	1	0	21.95	0.23	22.18	1.00	30.00	PASS
			1	37	22.18	0.23	22.41	1.00	30.00	PASS
			1	74	21.82	0.23	22.05	1.00	30.00	PASS
			36	0	20.94	0.23	21.17	1.00	30.00	PASS
			36	18	20.99	0.23	21.22	1.00	30.00	PASS
			36	39	20.97	0.23	21.20	1.00	30.00	PASS
			75	0	20.91	0.23	21.14	1.00	30.00	PASS
	Highest	QPSK	1	0	22.98	0.23	23.21	1.00	30.00	PASS
			1	37	23.35	0.23	23.58	1.00	30.00	PASS
			1	74	23.03	0.23	23.26	1.00	30.00	PASS
			36	0	22.10	0.23	22.33	1.00	30.00	PASS
			36	18	22.09	0.23	22.32	1.00	30.00	PASS
			36	39	22.08	0.23	22.31	1.00	30.00	PASS
			75	0	22.09	0.23	22.32	1.00	30.00	PASS
		16QAM	1	0	21.94	0.23	22.17	1.00	30.00	PASS
1			37	22.34	0.23	22.57	1.00	30.00	PASS	
1			74	22.01	0.23	22.24	1.00	30.00	PASS	
36			0	21.03	0.23	21.26	1.00	30.00	PASS	
36			18	21.01	0.23	21.24	1.00	30.00	PASS	
36			39	20.99	0.23	21.22	1.00	30.00	PASS	
75			0	21.06	0.23	21.29	1.00	30.00	PASS	



Radiated Power (EIRP) for LTE Band 4 /20M										
BW (MHz)	UL Channel	RB Size	RB offset	Modulation	Conduction AVG Power(dBm)	Ant Gain (dBi)	EIRP (dBm)	EIRP Limit(W)	EIRP Limit(dBm)	Verdict
20	Lowest	1	0	QPSK	22.99	0.23	23.22	1.00	30.00	PASS
		1	49		23.57	0.23	23.80	1.00	30.00	PASS
		1	99		22.79	0.23	23.02	1.00	30.00	PASS
		50	0		22.18	0.23	22.41	1.00	30.00	PASS
		50	24		22.23	0.23	22.46	1.00	30.00	PASS
		50	49		22.24	0.23	22.47	1.00	30.00	PASS
		100	0		22.22	0.23	22.45	1.00	30.00	PASS
		1	0	16QAM	22.28	0.23	22.51	1.00	30.00	PASS
		1	49		22.59	0.23	22.82	1.00	30.00	PASS
		1	99		21.99	0.23	22.22	1.00	30.00	PASS
		50	0		21.23	0.23	21.46	1.00	30.00	PASS
		50	24		21.24	0.23	21.47	1.00	30.00	PASS
		50	49		21.31	0.23	21.54	1.00	30.00	PASS
		100	0		21.24	0.23	21.47	1.00	30.00	PASS
	Middle	1	0	QPSK	23.00	0.23	23.23	1.00	30.00	PASS
		1	49		23.20	0.23	23.43	1.00	30.00	PASS
		1	99		22.85	0.23	23.08	1.00	30.00	PASS
		50	0		21.95	0.23	22.18	1.00	30.00	PASS
		50	24		21.94	0.23	22.17	1.00	30.00	PASS
		50	49		21.84	0.23	22.07	1.00	30.00	PASS
		100	0		21.87	0.23	22.10	1.00	30.00	PASS
		1	0	16QAM	22.11	0.23	22.34	1.00	30.00	PASS
		1	49		22.13	0.23	22.36	1.00	30.00	PASS
		1	99		21.84	0.23	22.07	1.00	30.00	PASS
		50	0		20.89	0.23	21.12	1.00	30.00	PASS
		50	24		20.87	0.23	21.10	1.00	30.00	PASS
		50	49		20.80	0.23	21.03	1.00	30.00	PASS
		100	0		20.85	0.23	21.08	1.00	30.00	PASS
	Highest	1	0	QPSK	22.73	0.23	22.96	1.00	30.00	PASS
		1	49		23.14	0.23	23.37	1.00	30.00	PASS
		1	99		22.81	0.23	23.04	1.00	30.00	PASS
		50	0		21.99	0.23	22.22	1.00	30.00	PASS
		50	24		22.00	0.23	22.23	1.00	30.00	PASS
		50	49		22.01	0.23	22.24	1.00	30.00	PASS
		100	0		22.00	0.23	22.23	1.00	30.00	PASS
		1	0	16QAM	21.85	0.23	22.08	1.00	30.00	PASS
1		49	22.25		0.23	22.48	1.00	30.00	PASS	
1		99	22.01		0.23	22.24	1.00	30.00	PASS	
50		0	20.98		0.23	21.21	1.00	30.00	PASS	
50		24	21.02		0.23	21.25	1.00	30.00	PASS	
50		49	20.97		0.23	21.20	1.00	30.00	PASS	
100		0	20.96		0.23	21.19	1.00	30.00	PASS	



Radiated Power (ERP) for LTE Band 5 /1.4M										
BW (MHz)	UL Channel	RB Size	RB offset	Modulation	Conduction AVG Power(dBm)	Ant Gain (dBi)	ERP (dBm)	ERP Limit(W)	ERP Limit(dBm)	Verdict
1.4	Lowest	1	0	QPSK	24.16	0.15	22.16	7.00	38.45	PASS
		1	2		24.36	0.15	22.36	7.00	38.45	PASS
		1	5		24.15	0.15	22.15	7.00	38.45	PASS
		3	0		24.15	0.15	22.15	7.00	38.45	PASS
		3	1		24.20	0.15	22.20	7.00	38.45	PASS
		3	2		24.16	0.15	22.16	7.00	38.45	PASS
		6	0		23.37	0.15	21.37	7.00	38.45	PASS
		1	0	16QAM	23.10	0.15	21.10	7.00	38.45	PASS
		1	2		23.14	0.15	21.14	7.00	38.45	PASS
		1	5		23.04	0.15	21.04	7.00	38.45	PASS
		3	0		23.21	0.15	21.21	7.00	38.45	PASS
		3	1		23.36	0.15	21.36	7.00	38.45	PASS
		3	2		23.05	0.15	21.05	7.00	38.45	PASS
		6	0		22.17	0.15	20.17	7.00	38.45	PASS
	Middle	QPSK	1	0	23.84	0.15	21.84	7.00	38.45	PASS
			1	2	23.94	0.15	21.94	7.00	38.45	PASS
			1	5	23.79	0.15	21.79	7.00	38.45	PASS
			3	0	23.88	0.15	21.88	7.00	38.45	PASS
			3	1	23.91	0.15	21.91	7.00	38.45	PASS
			3	2	23.84	0.15	21.84	7.00	38.45	PASS
			6	0	22.92	0.15	20.92	7.00	38.45	PASS
		16QAM	1	0	22.92	0.15	20.92	7.00	38.45	PASS
			1	2	23.01	0.15	21.01	7.00	38.45	PASS
			1	5	22.92	0.15	20.92	7.00	38.45	PASS
			3	0	23.02	0.15	21.02	7.00	38.45	PASS
			3	1	23.03	0.15	21.03	7.00	38.45	PASS
			3	2	23.01	0.15	21.01	7.00	38.45	PASS
			6	0	21.98	0.15	19.98	7.00	38.45	PASS
	Highest	QPSK	1	0	23.83	0.15	21.83	7.00	38.45	PASS
			1	2	23.98	0.15	21.98	7.00	38.45	PASS
			1	5	23.87	0.15	21.87	7.00	38.45	PASS
			3	0	23.76	0.15	21.76	7.00	38.45	PASS
			3	1	23.75	0.15	21.75	7.00	38.45	PASS
			3	2	23.72	0.15	21.72	7.00	38.45	PASS
			6	0	22.82	0.15	20.82	7.00	38.45	PASS
		16QAM	1	0	22.49	0.15	20.49	7.00	38.45	PASS
1			2	22.65	0.15	20.65	7.00	38.45	PASS	
1			5	22.46	0.15	20.46	7.00	38.45	PASS	
3			0	22.82	0.15	20.82	7.00	38.45	PASS	
3			1	22.82	0.15	20.82	7.00	38.45	PASS	
3			2	22.84	0.15	20.84	7.00	38.45	PASS	
6			0	21.89	0.15	19.89	7.00	38.45	PASS	





Radiated Power (ERP) for LTE Band 5 /3M										
BW (MHz)	UL Channel	RB Size	RB offset	Modulation	Conduction AVG Power(dBm)	Ant Gain (dBi)	ERP (dBm)	ERP Limit(W)	ERP Limit(dBm)	Verdict
3	Lowest	1	0	QPSK	23.78	0.15	21.78	7.00	38.45	PASS
		1	7		24.03	0.15	22.03	7.00	38.45	PASS
		1	14		23.84	0.15	21.84	7.00	38.45	PASS
		8	0		22.79	0.15	20.79	7.00	38.45	PASS
		8	4		22.84	0.15	20.84	7.00	38.45	PASS
		8	7		22.86	0.15	20.86	7.00	38.45	PASS
		15	0		22.74	0.15	20.74	7.00	38.45	PASS
		1	0	16QAM	23.09	0.15	21.09	7.00	38.45	PASS
		1	7		23.41	0.15	21.41	7.00	38.45	PASS
		1	14		23.14	0.15	21.14	7.00	38.45	PASS
		8	0		21.79	0.15	19.79	7.00	38.45	PASS
		8	4		21.78	0.15	19.78	7.00	38.45	PASS
		8	7		21.79	0.15	19.79	7.00	38.45	PASS
		15	0		21.72	0.15	19.72	7.00	38.45	PASS
		Middle	QPSK	1	0	23.89	0.15	21.89	7.00	38.45
	1			7	24.18	0.15	22.18	7.00	38.45	PASS
	1			14	23.87	0.15	21.87	7.00	38.45	PASS
	8			0	22.90	0.15	20.90	7.00	38.45	PASS
	8			4	22.93	0.15	20.93	7.00	38.45	PASS
	8			7	22.89	0.15	20.89	7.00	38.45	PASS
	15			0	22.84	0.15	20.84	7.00	38.45	PASS
	16QAM		1	0	22.98	0.15	20.98	7.00	38.45	PASS
			1	7	23.29	0.15	21.29	7.00	38.45	PASS
			1	14	22.97	0.15	20.97	7.00	38.45	PASS
			8	0	21.82	0.15	19.82	7.00	38.45	PASS
			8	4	21.85	0.15	19.85	7.00	38.45	PASS
			8	7	21.81	0.15	19.81	7.00	38.45	PASS
			15	0	21.73	0.15	19.73	7.00	38.45	PASS
			Highest	QPSK	1	0	23.93	0.15	21.93	7.00
	1	7			24.29	0.15	22.29	7.00	38.45	PASS
	1	14			23.95	0.15	21.95	7.00	38.45	PASS
	8	0			22.85	0.15	20.85	7.00	38.45	PASS
	8	4			22.85	0.15	20.85	7.00	38.45	PASS
	8	7			22.80	0.15	20.80	7.00	38.45	PASS
	15	0			22.77	0.15	20.77	7.00	38.45	PASS
	16QAM	1		0	22.61	0.15	20.61	7.00	38.45	PASS
1		7		22.76	0.15	20.76	7.00	38.45	PASS	
1		14		22.52	0.15	20.52	7.00	38.45	PASS	
8		0		21.73	0.15	19.73	7.00	38.45	PASS	
8		4		21.76	0.15	19.76	7.00	38.45	PASS	
8		7		21.72	0.15	19.72	7.00	38.45	PASS	
15		0		21.76	0.15	19.76	7.00	38.45	PASS	



Radiated Power (ERP) for LTE Band 5 /5M										
BW (MHz)	UL Channel	RB Size	RB offset	Modulation	Conduction AVG Power(dBm)	Ant Gain (dBi)	ERP (dBm)	ERP Limit(W)	ERP Limit(dBm)	Verdict
5	Lowest	1	0	QPSK	23.71	0.15	21.71	7.00	38.45	PASS
		1	12		24.11	0.15	22.11	7.00	38.45	PASS
		1	24		23.81	0.15	21.81	7.00	38.45	PASS
		12	0		22.77	0.15	20.77	7.00	38.45	PASS
		12	6		22.84	0.15	20.84	7.00	38.45	PASS
		12	11		22.85	0.15	20.85	7.00	38.45	PASS
		25	0		22.85	0.15	20.85	7.00	38.45	PASS
		1	0	16QAM	23.13	0.15	21.13	7.00	38.45	PASS
		1	12		23.63	0.15	21.63	7.00	38.45	PASS
		1	24		23.22	0.15	21.22	7.00	38.45	PASS
		12	0		21.71	0.15	19.71	7.00	38.45	PASS
		12	6		21.83	0.15	19.83	7.00	38.45	PASS
		12	11		21.80	0.15	19.80	7.00	38.45	PASS
		25	0		21.74	0.15	19.74	7.00	38.45	PASS
		Middle	QPSK	1	0	23.84	0.15	21.84	7.00	38.45
	1			12	24.31	0.15	22.31	7.00	38.45	PASS
	1			24	23.84	0.15	21.84	7.00	38.45	PASS
	12			0	22.83	0.15	20.83	7.00	38.45	PASS
	12			6	22.92	0.15	20.92	7.00	38.45	PASS
	12			11	22.80	0.15	20.80	7.00	38.45	PASS
	25			0	22.86	0.15	20.86	7.00	38.45	PASS
	16QAM		1	0	23.01	0.15	21.01	7.00	38.45	PASS
			1	12	23.40	0.15	21.40	7.00	38.45	PASS
			1	24	23.00	0.15	21.00	7.00	38.45	PASS
			12	0	21.78	0.15	19.78	7.00	38.45	PASS
			12	6	21.78	0.15	19.78	7.00	38.45	PASS
			12	11	21.73	0.15	19.73	7.00	38.45	PASS
			25	0	21.84	0.15	19.84	7.00	38.45	PASS
			Highest	QPSK	1	0	23.75	0.15	21.75	7.00
	1	12			24.06	0.15	22.06	7.00	38.45	PASS
1	24	23.67			0.15	21.67	7.00	38.45	PASS	
12	0	22.78			0.15	20.78	7.00	38.45	PASS	
12	6	22.86			0.15	20.86	7.00	38.45	PASS	
12	11	22.68			0.15	20.68	7.00	38.45	PASS	
25	0	22.79			0.15	20.79	7.00	38.45	PASS	
16QAM	1	0		22.96	0.15	20.96	7.00	38.45	PASS	
	1	12		23.28	0.15	21.28	7.00	38.45	PASS	
	1	24		22.82	0.15	20.82	7.00	38.45	PASS	
	12	0		21.86	0.15	19.86	7.00	38.45	PASS	
	12	6		21.84	0.15	19.84	7.00	38.45	PASS	
	12	11		21.71	0.15	19.71	7.00	38.45	PASS	
	25	0		21.71	0.15	19.71	7.00	38.45	PASS	





Radiated Power (ERP) for LTE Band 5 /10M										
BW (MHz)	UL Channel	RB Size	RB offset	Modulation	Conduction AVG Power(dBm)	Ant Gain (dBi)	ERP (dBm)	ERP Limit(W)	ERP Limit(dBm)	Verdict
10	Lowest	1	0	QPSK	23.74	0.15	21.74	7.00	38.45	PASS
		1	24		23.98	0.15	21.98	7.00	38.45	PASS
		1	49		23.89	0.15	21.89	7.00	38.45	PASS
		25	0		22.88	0.15	20.88	7.00	38.45	PASS
		25	12		22.87	0.15	20.87	7.00	38.45	PASS
		25	24		22.95	0.15	20.95	7.00	38.45	PASS
		50	0		22.92	0.15	20.92	7.00	38.45	PASS
		1	0	16QAM	23.04	0.15	21.04	7.00	38.45	PASS
		1	24		23.28	0.15	21.28	7.00	38.45	PASS
		1	49		23.21	0.15	21.21	7.00	38.45	PASS
		25	0		21.85	0.15	19.85	7.00	38.45	PASS
		25	12		21.84	0.15	19.84	7.00	38.45	PASS
		25	24		21.92	0.15	19.92	7.00	38.45	PASS
		50	0		21.84	0.15	19.84	7.00	38.45	PASS
	Middle	QPSK	1	0	23.88	0.15	21.88	7.00	38.45	PASS
			1	24	24.04	0.15	22.04	7.00	38.45	PASS
			1	49	23.89	0.15	21.89	7.00	38.45	PASS
			25	0	22.90	0.15	20.90	7.00	38.45	PASS
			25	12	22.87	0.15	20.87	7.00	38.45	PASS
			25	24	22.90	0.15	20.90	7.00	38.45	PASS
			50	0	22.88	0.15	20.88	7.00	38.45	PASS
		16QAM	1	0	22.94	0.15	20.94	7.00	38.45	PASS
			1	24	23.05	0.15	21.05	7.00	38.45	PASS
			1	49	22.93	0.15	20.93	7.00	38.45	PASS
			25	0	21.84	0.15	19.84	7.00	38.45	PASS
			25	12	21.83	0.15	19.83	7.00	38.45	PASS
			25	24	21.83	0.15	19.83	7.00	38.45	PASS
			50	0	21.83	0.15	19.83	7.00	38.45	PASS
	Highest	QPSK	1	0	24.02	0.15	22.02	7.00	38.45	PASS
			1	24	24.39	0.15	22.39	7.00	38.45	PASS
			1	49	23.89	0.15	21.89	7.00	38.45	PASS
			25	0	22.92	0.15	20.92	7.00	38.45	PASS
			25	12	22.86	0.15	20.86	7.00	38.45	PASS
			25	24	22.83	0.15	20.83	7.00	38.45	PASS
			50	0	22.84	0.15	20.84	7.00	38.45	PASS
		16QAM	1	0	22.64	0.15	20.64	7.00	38.45	PASS
1			24	22.69	0.15	20.69	7.00	38.45	PASS	
1			49	22.52	0.15	20.52	7.00	38.45	PASS	
25			0	21.88	0.15	19.88	7.00	38.45	PASS	
25			12	21.81	0.15	19.81	7.00	38.45	PASS	
25			24	21.77	0.15	19.77	7.00	38.45	PASS	
50			0	21.81	0.15	19.81	7.00	38.45	PASS	



Radiated Power (EIRP) for LTE Band 7 /5M										
BW (MHz)	UL Channel	RB Size	RB offset	Modulation	Conduction AVG Power(dBm)	Ant Gain (dBi)	EIRP (dBm)	EIRP Limit(W)	EIRP Limit(dBm)	Verdict
5	Lowest	1	0	QPSK	23.15	0.27	23.42	2.00	33.01	PASS
		1	12		23.57	0.27	23.84	2.00	33.01	PASS
		1	24		23.26	0.27	23.53	2.00	33.01	PASS
		12	0		22.34	0.27	22.61	2.00	33.01	PASS
		12	6		22.27	0.27	22.54	2.00	33.01	PASS
		12	11		22.22	0.27	22.49	2.00	33.01	PASS
		25	0		22.21	0.27	22.48	2.00	33.01	PASS
		1	0	16QAM	22.68	0.27	22.95	2.00	33.01	PASS
		1	12		22.92	0.27	23.19	2.00	33.01	PASS
		1	24		22.48	0.27	22.75	2.00	33.01	PASS
		12	0		20.94	0.27	21.21	2.00	33.01	PASS
		12	6		20.94	0.27	21.21	2.00	33.01	PASS
		12	11		21.13	0.27	21.40	2.00	33.01	PASS
		25	0		20.90	0.27	21.17	2.00	33.01	PASS
		Middle	QPSK	1	0	23.18	0.27	23.45	2.00	33.01
	1			12	23.65	0.27	23.92	2.00	33.01	PASS
	1			24	23.19	0.27	23.46	2.00	33.01	PASS
	12			0	22.19	0.27	22.46	2.00	33.01	PASS
	12			6	22.30	0.27	22.57	2.00	33.01	PASS
	12			11	22.34	0.27	22.61	2.00	33.01	PASS
	25			0	22.29	0.27	22.56	2.00	33.01	PASS
	16QAM		1	0	22.48	0.27	22.75	2.00	33.01	PASS
			1	12	22.86	0.27	23.13	2.00	33.01	PASS
			1	24	22.50	0.27	22.77	2.00	33.01	PASS
			12	0	21.08	0.27	21.35	2.00	33.01	PASS
			12	6	21.24	0.27	21.51	2.00	33.01	PASS
			12	11	21.25	0.27	21.52	2.00	33.01	PASS
			25	0	21.25	0.27	21.52	2.00	33.01	PASS
			Highest	QPSK	1	0	23.36	0.27	23.63	2.00
	1	12			23.86	0.27	24.13	2.00	33.01	PASS
	1	24			23.42	0.27	23.69	2.00	33.01	PASS
	12	0			22.50	0.27	22.77	2.00	33.01	PASS
	12	6			22.53	0.27	22.80	2.00	33.01	PASS
	12	11			22.48	0.27	22.75	2.00	33.01	PASS
	25	0			22.49	0.27	22.76	2.00	33.01	PASS
	16QAM	1		0	22.62	0.27	22.89	2.00	33.01	PASS
		1		12	23.03	0.27	23.30	2.00	33.01	PASS
		1		24	22.69	0.27	22.96	2.00	33.01	PASS
		12		0	21.46	0.27	21.73	2.00	33.01	PASS
		12		6	21.52	0.27	21.79	2.00	33.01	PASS
		12		11	21.54	0.27	21.81	2.00	33.01	PASS
		25		0	21.42	0.27	21.69	2.00	33.01	PASS



Radiated Power (EIRP) for LTE Band 7 /10M										
BW (MHz)	UL Channel	RB Size	RB offset	Modulation	Conduction AVG Power(dBm)	Ant Gain (dBi)	EIRP (dBm)	EIRP Limit(W)	EIRP Limit(dBm)	Verdict
10	Lowest	1	0	QPSK	22.69	0.27	22.96	2.00	33.01	PASS
		1	24		22.94	0.27	23.21	2.00	33.01	PASS
		1	49		22.91	0.27	23.18	2.00	33.01	PASS
		25	0		21.72	0.27	21.99	2.00	33.01	PASS
		25	12		21.84	0.27	22.11	2.00	33.01	PASS
		25	24		21.91	0.27	22.18	2.00	33.01	PASS
		50	0		21.83	0.27	22.10	2.00	33.01	PASS
		1	0	16QAM	22.09	0.27	22.36	2.00	33.01	PASS
		1	24		22.31	0.27	22.58	2.00	33.01	PASS
		1	49		22.21	0.27	22.48	2.00	33.01	PASS
		25	0		20.73	0.27	21.00	2.00	33.01	PASS
		25	12		20.81	0.27	21.08	2.00	33.01	PASS
		25	24		20.88	0.27	21.15	2.00	33.01	PASS
		50	0		20.80	0.27	21.07	2.00	33.01	PASS
	Middle	QPSK	1	0	23.23	0.27	23.50	2.00	33.01	PASS
			1	24	23.36	0.27	23.63	2.00	33.01	PASS
			1	49	23.36	0.27	23.63	2.00	33.01	PASS
			25	0	22.27	0.27	22.54	2.00	33.01	PASS
			25	12	22.32	0.27	22.59	2.00	33.01	PASS
			25	24	22.43	0.27	22.70	2.00	33.01	PASS
			50	0	22.33	0.27	22.60	2.00	33.01	PASS
		16QAM	1	0	22.25	0.27	22.52	2.00	33.01	PASS
			1	24	22.53	0.27	22.80	2.00	33.01	PASS
			1	49	22.49	0.27	22.76	2.00	33.01	PASS
			25	0	21.23	0.27	21.50	2.00	33.01	PASS
			25	12	21.29	0.27	21.56	2.00	33.01	PASS
			25	24	21.37	0.27	21.64	2.00	33.01	PASS
			50	0	21.31	0.27	21.58	2.00	33.01	PASS
	Highest	QPSK	1	0	23.59	0.27	23.86	2.00	33.01	PASS
			1	24	23.70	0.27	23.97	2.00	33.01	PASS
			1	49	23.58	0.27	23.85	2.00	33.01	PASS
			25	0	22.51	0.27	22.78	2.00	33.01	PASS
			25	12	22.48	0.27	22.75	2.00	33.01	PASS
			25	24	22.57	0.27	22.84	2.00	33.01	PASS
			50	0	22.53	0.27	22.80	2.00	33.01	PASS
		16QAM	1	0	22.21	0.27	22.48	2.00	33.01	PASS
1			24	22.47	0.27	22.74	2.00	33.01	PASS	
1			49	22.28	0.27	22.55	2.00	33.01	PASS	
25			0	21.45	0.27	21.72	2.00	33.01	PASS	
25			12	21.48	0.27	21.75	2.00	33.01	PASS	
25			24	21.55	0.27	21.82	2.00	33.01	PASS	
50			0	21.49	0.27	21.76	2.00	33.01	PASS	



Radiated Power (EIRP) for LTE Band 7 /15M										
BW (MHz)	UL Channel	RB Size	RB offset	Modulation	Conduction AVG Power(dBm)	Ant Gain (dBi)	EIRP (dBm)	EIRP Limit(W)	EIRP Limit(dBm)	Verdict
15	Lowest	1	0	QPSK	22.72	0.27	22.99	2.00	33.01	PASS
		1	37		23.22	0.27	23.49	2.00	33.01	PASS
		1	74		22.97	0.27	23.24	2.00	33.01	PASS
		36	0		21.82	0.27	22.09	2.00	33.01	PASS
		36	18		21.96	0.27	22.23	2.00	33.01	PASS
		36	39		22.00	0.27	22.27	2.00	33.01	PASS
		75	0		21.90	0.27	22.17	2.00	33.01	PASS
		1	0	16QAM	21.75	0.27	22.02	2.00	33.01	PASS
		1	37		22.26	0.27	22.53	2.00	33.01	PASS
		1	74		21.89	0.27	22.16	2.00	33.01	PASS
		36	0		20.79	0.27	21.06	2.00	33.01	PASS
		36	18		20.89	0.27	21.16	2.00	33.01	PASS
		36	39		20.89	0.27	21.16	2.00	33.01	PASS
		75	0		20.88	0.27	21.15	2.00	33.01	PASS
	Middle	QPSK	1	0	23.09	0.27	23.36	2.00	33.01	PASS
			1	37	23.51	0.27	23.78	2.00	33.01	PASS
			1	74	23.29	0.27	23.56	2.00	33.01	PASS
			36	0	22.25	0.27	22.52	2.00	33.01	PASS
			36	18	22.29	0.27	22.56	2.00	33.01	PASS
			36	39	22.43	0.27	22.70	2.00	33.01	PASS
			75	0	22.37	0.27	22.64	2.00	33.01	PASS
		16QAM	1	0	22.41	0.27	22.68	2.00	33.01	PASS
			1	37	22.86	0.27	23.13	2.00	33.01	PASS
			1	74	22.64	0.27	22.91	2.00	33.01	PASS
			36	0	21.22	0.27	21.49	2.00	33.01	PASS
			36	18	21.33	0.27	21.60	2.00	33.01	PASS
			36	39	21.44	0.27	21.71	2.00	33.01	PASS
			75	0	21.29	0.27	21.56	2.00	33.01	PASS
	Highest	QPSK	1	0	23.40	0.27	23.67	2.00	33.01	PASS
			1	37	23.73	0.27	24.00	2.00	33.01	PASS
			1	74	23.43	0.27	23.70	2.00	33.01	PASS
			36	0	22.63	0.27	22.90	2.00	33.01	PASS
			36	18	22.61	0.27	22.88	2.00	33.01	PASS
			36	39	22.58	0.27	22.85	2.00	33.01	PASS
			75	0	22.65	0.27	22.92	2.00	33.01	PASS
		16QAM	1	0	22.44	0.27	22.71	2.00	33.01	PASS
1			37	22.69	0.27	22.96	2.00	33.01	PASS	
1			74	22.57	0.27	22.84	2.00	33.01	PASS	
36			0	21.59	0.27	21.86	2.00	33.01	PASS	
36			18	21.57	0.27	21.84	2.00	33.01	PASS	
36			39	21.62	0.27	21.89	2.00	33.01	PASS	
75			0	21.53	0.27	21.80	2.00	33.01	PASS	



Radiated Power (EIRP) for LTE Band 7 /20M										
BW (MHz)	UL Channel	RB Size	RB offset	Modulation	Conduction AVG Power(dBm)	Ant Gain (dBi)	EIRP (dBm)	EIRP Limit(W)	EIRP Limit(dBm)	Verdict
20	Lowest	1	0	QPSK	22.52	0.27	22.79	2.00	33.01	PASS
		1	49		23.11	0.27	23.38	2.00	33.01	PASS
		1	99		22.80	0.27	23.07	2.00	33.01	PASS
		50	0		21.78	0.27	22.05	2.00	33.01	PASS
		50	24		21.86	0.27	22.13	2.00	33.01	PASS
		50	49		21.88	0.27	22.15	2.00	33.01	PASS
		100	0		21.80	0.27	22.07	2.00	33.01	PASS
		1	0	16QAM	21.86	0.27	22.13	2.00	33.01	PASS
		1	49		22.22	0.27	22.49	2.00	33.01	PASS
		1	99		21.91	0.27	22.18	2.00	33.01	PASS
		50	0		20.78	0.27	21.05	2.00	33.01	PASS
		50	24		20.88	0.27	21.15	2.00	33.01	PASS
		50	49		20.83	0.27	21.10	2.00	33.01	PASS
		100	0		20.81	0.27	21.08	2.00	33.01	PASS
	1	0	QPSK	23.00	0.27	23.27	2.00	33.01	PASS	
	1	49		23.48	0.27	23.75	2.00	33.01	PASS	
	1	99		23.26	0.27	23.53	2.00	33.01	PASS	
	50	0		22.17	0.27	22.44	2.00	33.01	PASS	
	50	24		22.29	0.27	22.56	2.00	33.01	PASS	
	50	49		22.45	0.27	22.72	2.00	33.01	PASS	
	100	0		22.32	0.27	22.59	2.00	33.01	PASS	
	1	0	16QAM	22.03	0.27	22.30	2.00	33.01	PASS	
	1	49		22.61	0.27	22.88	2.00	33.01	PASS	
	1	99		22.40	0.27	22.67	2.00	33.01	PASS	
	50	0		21.13	0.27	21.40	2.00	33.01	PASS	
	50	24		21.28	0.27	21.55	2.00	33.01	PASS	
	50	49		21.42	0.27	21.69	2.00	33.01	PASS	
	100	0		21.33	0.27	21.60	2.00	33.01	PASS	
	1	0	QPSK	23.29	0.27	23.56	2.00	33.01	PASS	
	1	49		23.88	0.27	24.15	2.00	33.01	PASS	
	1	99		23.28	0.27	23.55	2.00	33.01	PASS	
	50	0		22.47	0.27	22.74	2.00	33.01	PASS	
	50	24		22.50	0.27	22.77	2.00	33.01	PASS	
	50	49		22.48	0.27	22.75	2.00	33.01	PASS	
	100	0		22.52	0.27	22.79	2.00	33.01	PASS	
	1	0	16QAM	22.39	0.27	22.66	2.00	33.01	PASS	
	1	49		22.70	0.27	22.97	2.00	33.01	PASS	
	1	99		22.48	0.27	22.75	2.00	33.01	PASS	
	50	0		21.46	0.27	21.73	2.00	33.01	PASS	
	50	24		21.46	0.27	21.73	2.00	33.01	PASS	
	50	49		21.47	0.27	21.74	2.00	33.01	PASS	
	100	0		21.45	0.27	21.72	2.00	33.01	PASS	





Radiated Power (ERP) for LTE Band 12 /1.4M										
BW (MHz)	UL Channel	RB Size	RB offset	Modulation	Conduction AVG Power(dBm)	Ant Gain (dBi)	ERP (dBm)	ERP Limit(W)	ERP Limit(dBm)	Verdict
1.4	Lowest	1	0	QPSK	23.71	0.05	21.61	3.00	34.77	PASS
		1	2		23.79	0.05	21.69	3.00	34.77	PASS
		1	5		23.69	0.05	21.59	3.00	34.77	PASS
		3	0		23.37	0.05	21.27	3.00	34.77	PASS
		3	1		23.46	0.05	21.36	3.00	34.77	PASS
		3	2		23.46	0.05	21.36	3.00	34.77	PASS
		6	0		22.61	0.05	20.51	3.00	34.77	PASS
		1	0	16QAM	22.48	0.05	20.38	3.00	34.77	PASS
		1	2		22.60	0.05	20.50	3.00	34.77	PASS
		1	5		22.52	0.05	20.42	3.00	34.77	PASS
		3	0		22.49	0.05	20.39	3.00	34.77	PASS
		3	1		22.50	0.05	20.40	3.00	34.77	PASS
		3	2		22.48	0.05	20.38	3.00	34.77	PASS
		6	0		21.64	0.05	19.54	3.00	34.77	PASS
	Middle	QPSK	1	0	23.55	0.05	21.45	3.00	34.77	PASS
			1	2	23.66	0.05	21.56	3.00	34.77	PASS
			1	5	23.56	0.05	21.46	3.00	34.77	PASS
			3	0	23.42	0.05	21.32	3.00	34.77	PASS
			3	1	23.45	0.05	21.35	3.00	34.77	PASS
			3	2	23.40	0.05	21.30	3.00	34.77	PASS
			6	0	22.67	0.05	20.57	3.00	34.77	PASS
		16QAM	1	0	22.54	0.05	20.44	3.00	34.77	PASS
			1	2	22.61	0.05	20.51	3.00	34.77	PASS
			1	5	22.48	0.05	20.38	3.00	34.77	PASS
			3	0	22.39	0.05	20.29	3.00	34.77	PASS
			3	1	22.41	0.05	20.31	3.00	34.77	PASS
			3	2	22.43	0.05	20.33	3.00	34.77	PASS
			6	0	21.59	0.05	19.49	3.00	34.77	PASS
	Highest	QPSK	1	0	23.38	0.05	21.28	3.00	34.77	PASS
			1	2	23.49	0.05	21.39	3.00	34.77	PASS
			1	5	23.25	0.05	21.15	3.00	34.77	PASS
			3	0	23.33	0.05	21.23	3.00	34.77	PASS
			3	1	23.34	0.05	21.24	3.00	34.77	PASS
			3	2	23.25	0.05	21.15	3.00	34.77	PASS
			6	0	22.69	0.05	20.59	3.00	34.77	PASS
		16QAM	1	0	22.27	0.05	20.17	3.00	34.77	PASS
1			2	22.41	0.05	20.31	3.00	34.77	PASS	
1			5	22.30	0.05	20.20	3.00	34.77	PASS	
3			0	22.41	0.05	20.31	3.00	34.77	PASS	
3			1	22.46	0.05	20.36	3.00	34.77	PASS	
3			2	22.42	0.05	20.32	3.00	34.77	PASS	
6			0	21.62	0.05	19.52	3.00	34.77	PASS	





Radiated Power (ERP) for LTE Band 12 /3M										
BW (MHz)	UL Channel	RB Size	RB offset	Modulation	Conduction AVG Power(dBm)	Ant Gain (dBi)	ERP (dBm)	ERP Limit(W)	ERP Limit(dBm)	Verdict
3	Lowest	1	0	QPSK	23.61	0.05	21.51	3.00	34.77	PASS
		1	7		23.98	0.05	21.88	3.00	34.77	PASS
		1	14		23.58	0.05	21.48	3.00	34.77	PASS
		8	0		22.54	0.05	20.44	3.00	34.77	PASS
		8	4		22.58	0.05	20.48	3.00	34.77	PASS
		8	7		22.52	0.05	20.42	3.00	34.77	PASS
		15	0		22.50	0.05	20.40	3.00	34.77	PASS
		1	0	16QAM	22.74	0.05	20.64	3.00	34.77	PASS
		1	7		23.05	0.05	20.95	3.00	34.77	PASS
		1	14		22.72	0.05	20.62	3.00	34.77	PASS
		8	0		21.50	0.05	19.40	3.00	34.77	PASS
		8	4		21.54	0.05	19.44	3.00	34.77	PASS
		8	7		21.50	0.05	19.40	3.00	34.77	PASS
		15	0		21.50	0.05	19.40	3.00	34.77	PASS
		Middle	QPSK	1	0	23.60	0.05	21.50	3.00	34.77
	1			7	23.80	0.05	21.70	3.00	34.77	PASS
	1			14	23.56	0.05	21.46	3.00	34.77	PASS
	8			0	22.59	0.05	20.49	3.00	34.77	PASS
	8			4	22.59	0.05	20.49	3.00	34.77	PASS
	8			7	22.54	0.05	20.44	3.00	34.77	PASS
	15			0	22.45	0.05	20.35	3.00	34.77	PASS
	16QAM		1	0	22.54	0.05	20.44	3.00	34.77	PASS
			1	7	22.76	0.05	20.66	3.00	34.77	PASS
			1	14	22.50	0.05	20.40	3.00	34.77	PASS
			8	0	21.46	0.05	19.36	3.00	34.77	PASS
			8	4	21.47	0.05	19.37	3.00	34.77	PASS
			8	7	21.45	0.05	19.35	3.00	34.77	PASS
			15	0	21.41	0.05	19.31	3.00	34.77	PASS
			Highest	QPSK	1	0	23.65	0.05	21.55	3.00
	1	7			23.57	0.05	21.47	3.00	34.77	PASS
	1	14			23.23	0.05	21.13	3.00	34.77	PASS
	8	0			22.60	0.05	20.50	3.00	34.77	PASS
	8	4			22.63	0.05	20.53	3.00	34.77	PASS
	8	7			22.56	0.05	20.46	3.00	34.77	PASS
	15	0			22.48	0.05	20.38	3.00	34.77	PASS
	16QAM	1		0	22.31	0.05	20.21	3.00	34.77	PASS
1		7		22.53	0.05	20.43	3.00	34.77	PASS	
1		14		22.34	0.05	20.24	3.00	34.77	PASS	
8		0		21.40	0.05	19.30	3.00	34.77	PASS	
8		4		21.34	0.05	19.24	3.00	34.77	PASS	
8		7		21.37	0.05	19.27	3.00	34.77	PASS	
15		0		21.38	0.05	19.28	3.00	34.77	PASS	



Radiated Power (ERP) for LTE Band 12 /5M										
BW (MHz)	UL Channel	RB Size	RB offset	Modulation	Conduction AVG Power(dBm)	Ant Gain (dBi)	ERP (dBm)	ERP Limit(W)	ERP Limit(dBm)	Verdict
5	Lowest	1	0	QPSK	23.56	0.05	21.46	3.00	34.77	PASS
		1	12		23.84	0.05	21.74	3.00	34.77	PASS
		1	24		23.56	0.05	21.46	3.00	34.77	PASS
		12	0		22.51	0.05	20.41	3.00	34.77	PASS
		12	6		22.54	0.05	20.44	3.00	34.77	PASS
		12	11		22.50	0.05	20.40	3.00	34.77	PASS
		25	0		22.55	0.05	20.45	3.00	34.77	PASS
		1	0	16QAM	22.69	0.05	20.59	3.00	34.77	PASS
		1	12		23.11	0.05	21.01	3.00	34.77	PASS
		1	24		22.75	0.05	20.65	3.00	34.77	PASS
		12	0		21.48	0.05	19.38	3.00	34.77	PASS
		12	6		21.52	0.05	19.42	3.00	34.77	PASS
		12	11		21.49	0.05	19.39	3.00	34.77	PASS
		25	0		21.50	0.05	19.40	3.00	34.77	PASS
	Middle	QPSK	1	0	23.54	0.05	21.44	3.00	34.77	PASS
			1	12	23.80	0.05	21.70	3.00	34.77	PASS
			1	24	23.58	0.05	21.48	3.00	34.77	PASS
			12	0	22.45	0.05	20.35	3.00	34.77	PASS
			12	6	22.48	0.05	20.38	3.00	34.77	PASS
			12	11	22.51	0.05	20.41	3.00	34.77	PASS
			25	0	22.56	0.05	20.46	3.00	34.77	PASS
		16QAM	1	0	22.61	0.05	20.51	3.00	34.77	PASS
			1	12	22.86	0.05	20.76	3.00	34.77	PASS
			1	24	22.50	0.05	20.40	3.00	34.77	PASS
			12	0	21.47	0.05	19.37	3.00	34.77	PASS
			12	6	21.48	0.05	19.38	3.00	34.77	PASS
			12	11	21.43	0.05	19.33	3.00	34.77	PASS
			25	0	21.51	0.05	19.41	3.00	34.77	PASS
	Highest	QPSK	1	0	23.43	0.05	21.33	3.00	34.77	PASS
			1	12	23.56	0.05	21.46	3.00	34.77	PASS
			1	24	23.07	0.05	20.97	3.00	34.77	PASS
			12	0	22.53	0.05	20.43	3.00	34.77	PASS
			12	6	22.52	0.05	20.42	3.00	34.77	PASS
			12	11	22.46	0.05	20.36	3.00	34.77	PASS
			25	0	22.56	0.05	20.46	3.00	34.77	PASS
		16QAM	1	0	22.43	0.05	20.33	3.00	34.77	PASS
1			12	22.82	0.05	20.72	3.00	34.77	PASS	
1			24	22.58	0.05	20.48	3.00	34.77	PASS	
12			0	21.51	0.05	19.41	3.00	34.77	PASS	
12			6	21.55	0.05	19.45	3.00	34.77	PASS	
12			11	21.33	0.05	19.23	3.00	34.77	PASS	
25			0	21.54	0.05	19.44	3.00	34.77	PASS	



Radiated Power (ERP) for LTE Band 12 /10M										
BW (MHz)	UL Channel	RB Size	RB offset	Modulation	Conduction AVG Power(dBm)	Ant Gain (dBi)	ERP (dBm)	ERP Limit(W)	ERP Limit(dBm)	Verdict
10	Lowest	1	0	QPSK	23.58	0.05	21.48	3.00	34.77	PASS
		1	24		23.70	0.05	21.60	3.00	34.77	PASS
		1	49		23.60	0.05	21.50	3.00	34.77	PASS
		25	0		22.59	0.05	20.49	3.00	34.77	PASS
		25	12		22.60	0.05	20.50	3.00	34.77	PASS
		25	24		22.60	0.05	20.50	3.00	34.77	PASS
		50	0		22.56	0.05	20.46	3.00	34.77	PASS
		1	0	16QAM	22.71	0.05	20.61	3.00	34.77	PASS
		1	24		22.88	0.05	20.78	3.00	34.77	PASS
		1	49		22.68	0.05	20.58	3.00	34.77	PASS
		25	0		21.58	0.05	19.48	3.00	34.77	PASS
		25	12		21.60	0.05	19.50	3.00	34.77	PASS
		25	24		21.60	0.05	19.50	3.00	34.77	PASS
		50	0		21.52	0.05	19.42	3.00	34.77	PASS
	Middle	QPSK	1	0	23.55	0.05	21.45	3.00	34.77	PASS
			1	24	23.65	0.05	21.55	3.00	34.77	PASS
			1	49	23.57	0.05	21.47	3.00	34.77	PASS
			25	0	22.55	0.05	20.45	3.00	34.77	PASS
			25	12	22.60	0.05	20.50	3.00	34.77	PASS
			25	24	22.52	0.05	20.42	3.00	34.77	PASS
			50	0	22.54	0.05	20.44	3.00	34.77	PASS
		16QAM	1	0	22.52	0.05	20.42	3.00	34.77	PASS
			1	24	22.63	0.05	20.53	3.00	34.77	PASS
			1	49	22.42	0.05	20.32	3.00	34.77	PASS
			25	0	21.54	0.05	19.44	3.00	34.77	PASS
			25	12	21.55	0.05	19.45	3.00	34.77	PASS
			25	24	21.47	0.05	19.37	3.00	34.77	PASS
			50	0	21.50	0.05	19.40	3.00	34.77	PASS
	Highest	QPSK	1	0	23.64	0.05	21.54	3.00	34.77	PASS
			1	24	24.01	0.05	21.91	3.00	34.77	PASS
			1	49	23.14	0.05	21.04	3.00	34.77	PASS
			25	0	22.62	0.05	20.52	3.00	34.77	PASS
			25	12	22.59	0.05	20.49	3.00	34.77	PASS
			25	24	22.52	0.05	20.42	3.00	34.77	PASS
			50	0	22.59	0.05	20.49	3.00	34.77	PASS
		16QAM	1	0	22.33	0.05	20.23	3.00	34.77	PASS
1			24	22.30	0.05	20.20	3.00	34.77	PASS	
1			49	22.39	0.05	20.29	3.00	34.77	PASS	
25			0	21.61	0.05	19.51	3.00	34.77	PASS	
25			12	21.57	0.05	19.47	3.00	34.77	PASS	
25			24	21.49	0.05	19.39	3.00	34.77	PASS	
50			0	21.58	0.05	19.48	3.00	34.77	PASS	



Radiated Power (ERP) for LTE Band 13 /5M										
BW (MHz)	UL Channel	RB Size	RB offset	Modulation	Conduction AVG Power(dBm)	Ant Gain (dBi)	ERP (dBm)	ERP Limit(W)	ERP Limit(dBm)	Verdict
5	Lowest	1	0	QPSK	24.00	0.12	21.97	3.00	34.77	PASS
		1	12		24.26	0.12	22.23	3.00	34.77	PASS
		1	24		23.72	0.12	21.69	3.00	34.77	PASS
		12	0		22.82	0.12	20.79	3.00	34.77	PASS
		12	6		22.87	0.12	20.84	3.00	34.77	PASS
		12	11		22.84	0.12	20.81	3.00	34.77	PASS
		25	0		22.87	0.12	20.84	3.00	34.77	PASS
		1	0	16QAM	22.97	0.12	20.94	3.00	34.77	PASS
		1	12		23.34	0.12	21.31	3.00	34.77	PASS
		1	24		23.21	0.12	21.18	3.00	34.77	PASS
		12	0		21.83	0.12	19.80	3.00	34.77	PASS
		12	6		21.89	0.12	19.86	3.00	34.77	PASS
		12	11		21.87	0.12	19.84	3.00	34.77	PASS
		25	0		21.82	0.12	19.79	3.00	34.77	PASS
		Middle	QPSK	1	0	23.91	0.12	21.88	3.00	34.77
	1			12	24.27	0.12	22.24	3.00	34.77	PASS
	1			24	23.82	0.12	21.79	3.00	34.77	PASS
	12			0	22.86	0.12	20.83	3.00	34.77	PASS
	12			6	22.93	0.12	20.90	3.00	34.77	PASS
	12			11	22.88	0.12	20.85	3.00	34.77	PASS
	25			0	22.93	0.12	20.90	3.00	34.77	PASS
	16QAM		1	0	22.87	0.12	20.84	3.00	34.77	PASS
			1	12	23.51	0.12	21.48	3.00	34.77	PASS
			1	24	23.10	0.12	21.07	3.00	34.77	PASS
			12	0	21.82	0.12	19.79	3.00	34.77	PASS
			12	6	21.93	0.12	19.90	3.00	34.77	PASS
			12	11	21.90	0.12	19.87	3.00	34.77	PASS
			25	0	21.94	0.12	19.91	3.00	34.77	PASS
			Highest	QPSK	1	0	23.76	0.12	21.73	3.00
	1	12			24.05	0.12	22.02	3.00	34.77	PASS
	1	24			23.93	0.12	21.90	3.00	34.77	PASS
	12	0			22.84	0.12	20.81	3.00	34.77	PASS
	12	6			22.90	0.12	20.87	3.00	34.77	PASS
	12	11			22.88	0.12	20.85	3.00	34.77	PASS
	25	0			22.94	0.12	20.91	3.00	34.77	PASS
	16QAM	1		0	23.11	0.12	21.08	3.00	34.77	PASS
1		12		23.42	0.12	21.39	3.00	34.77	PASS	
1		24		22.80	0.12	20.77	3.00	34.77	PASS	
12		0		21.87	0.12	19.84	3.00	34.77	PASS	
12		6		21.96	0.12	19.93	3.00	34.77	PASS	
12		11		21.87	0.12	19.84	3.00	34.77	PASS	
25		0		21.85	0.12	19.82	3.00	34.77	PASS	



Radiated Power (ERP) for LTE Band 13 /10M										
BW (MHz)	UL Channel	RB Size	RB offset	Modulation	Conduction AVG Power(dBm)	Ant Gain (dBi)	ERP (dBm)	ERP Limit(W)	ERP Limit(dBm)	Verdict
10	Middle	1	0	QPSK	24.01	0.12	21.98	3.00	34.77	PASS
		1	24		23.93	0.12	21.90	3.00	34.77	PASS
		1	49		24.29	0.12	22.26	3.00	34.77	PASS
		25	0		22.95	0.12	20.92	3.00	34.77	PASS
		25	12		22.92	0.12	20.89	3.00	34.77	PASS
		25	24		23.05	0.12	21.02	3.00	34.77	PASS
		50	0		22.97	0.12	20.94	3.00	34.77	PASS
		1	0	16QAM	22.72	0.12	20.69	3.00	34.77	PASS
		1	24		23.05	0.12	21.02	3.00	34.77	PASS
		1	49		22.72	0.12	20.69	3.00	34.77	PASS
		25	0		21.80	0.12	19.77	3.00	34.77	PASS
		25	12		21.67	0.12	19.64	3.00	34.77	PASS
		25	24		21.84	0.12	19.81	3.00	34.77	PASS
		50	0		21.83	0.12	19.80	3.00	34.77	PASS







Radiated Power (ERP) for LTE Band 17 /5M										
BW (MHz)	UL Channel	RB Size	RB offset	Modulation	Conduction AVG Power(dBm)	Ant Gain (dBi)	ERP (dBm)	ERP Limit(W)	ERP Limit(dBm)	Verdict
5	Lowest	1	0	QPSK	24.20	0.05	22.10	3.00	34.77	PASS
		1	12		24.58	0.05	22.48	3.00	34.77	PASS
		1	24		24.23	0.05	22.13	3.00	34.77	PASS
		12	0		23.19	0.05	21.09	3.00	34.77	PASS
		12	6		23.21	0.05	21.11	3.00	34.77	PASS
		12	11		23.15	0.05	21.05	3.00	34.77	PASS
		25	0	23.14	0.05	21.04	3.00	34.77	PASS	
		1	0	16QAM	23.35	0.05	21.25	3.00	34.77	PASS
		1	12		23.57	0.05	21.47	3.00	34.77	PASS
		1	24		23.37	0.05	21.27	3.00	34.77	PASS
		12	0		22.07	0.05	19.97	3.00	34.77	PASS
		12	6		22.12	0.05	20.02	3.00	34.77	PASS
		12	11		22.12	0.05	20.02	3.00	34.77	PASS
		25	0	22.10	0.05	20.00	3.00	34.77	PASS	
		Middle	QPSK	1	0	24.24	0.05	22.14	3.00	34.77
	1			12	24.57	0.05	22.47	3.00	34.77	PASS
	1			24	24.27	0.05	22.17	3.00	34.77	PASS
	12			0	23.14	0.05	21.04	3.00	34.77	PASS
	12			6	23.16	0.05	21.06	3.00	34.77	PASS
	12			11	23.16	0.05	21.06	3.00	34.77	PASS
	25		0	23.19	0.05	21.09	3.00	34.77	PASS	
	16QAM		1	0	23.40	0.05	21.30	3.00	34.77	PASS
			1	12	23.70	0.05	21.60	3.00	34.77	PASS
			1	24	23.28	0.05	21.18	3.00	34.77	PASS
			12	0	22.15	0.05	20.05	3.00	34.77	PASS
			12	6	22.22	0.05	20.12	3.00	34.77	PASS
			12	11	22.21	0.05	20.11	3.00	34.77	PASS
	25		0	22.16	0.05	20.06	3.00	34.77	PASS	
	Highest		QPSK	1	0	24.35	0.05	22.25	3.00	34.77
		1		12	24.50	0.05	22.40	3.00	34.77	PASS
1		24		24.00	0.05	21.90	3.00	34.77	PASS	
12		0		23.21	0.05	21.11	3.00	34.77	PASS	
12		6		23.19	0.05	21.09	3.00	34.77	PASS	
12		11		23.11	0.05	21.01	3.00	34.77	PASS	
25		0	23.20	0.05	21.10	3.00	34.77	PASS		
16QAM		1	0	23.15	0.05	21.05	3.00	34.77	PASS	
		1	12	23.58	0.05	21.48	3.00	34.77	PASS	
		1	24	23.20	0.05	21.10	3.00	34.77	PASS	
		12	0	22.20	0.05	20.10	3.00	34.77	PASS	
		12	6	22.20	0.05	20.10	3.00	34.77	PASS	
		12	11	21.97	0.05	19.87	3.00	34.77	PASS	
25		0	22.28	0.05	20.18	3.00	34.77	PASS		





Radiated Power (ERP) for LTE Band 17 /10M										
BW (MHz)	UL Channel	RB Size	RB offset	Modulation	Conduction AVG Power(dBm)	Ant Gain (dBi)	ERP (dBm)	ERP Limit(W)	ERP Limit(dBm)	Verdict
10	Lowest	1	0	QPSK	24.40	0.05	22.30	3.00	34.77	PASS
		1	24		24.62	0.05	22.52	3.00	34.77	PASS
		1	49		24.45	0.05	22.35	3.00	34.77	PASS
		25	0		23.26	0.05	21.16	3.00	34.77	PASS
		25	12		23.26	0.05	21.16	3.00	34.77	PASS
		25	24		23.15	0.05	21.05	3.00	34.77	PASS
		50	0		23.21	0.05	21.11	3.00	34.77	PASS
		1	0	16QAM	23.05	0.05	20.95	3.00	34.77	PASS
		1	24		23.11	0.05	21.01	3.00	34.77	PASS
		1	49		22.97	0.05	20.87	3.00	34.77	PASS
		25	0		22.31	0.05	20.21	3.00	34.77	PASS
		25	12		22.28	0.05	20.18	3.00	34.77	PASS
		25	24		22.19	0.05	20.09	3.00	34.77	PASS
		50	0		22.21	0.05	20.11	3.00	34.77	PASS
	Middle	QPSK	1	0	24.29	0.05	22.19	3.00	34.77	PASS
			1	24	24.45	0.05	22.35	3.00	34.77	PASS
			1	49	24.26	0.05	22.16	3.00	34.77	PASS
			25	0	23.22	0.05	21.12	3.00	34.77	PASS
			25	12	23.27	0.05	21.17	3.00	34.77	PASS
			25	24	23.19	0.05	21.09	3.00	34.77	PASS
			50	0	23.23	0.05	21.13	3.00	34.77	PASS
		16QAM	1	0	23.42	0.05	21.32	3.00	34.77	PASS
			1	24	23.47	0.05	21.37	3.00	34.77	PASS
			1	49	23.38	0.05	21.28	3.00	34.77	PASS
			25	0	22.30	0.05	20.20	3.00	34.77	PASS
			25	12	22.31	0.05	20.21	3.00	34.77	PASS
			25	24	22.20	0.05	20.10	3.00	34.77	PASS
			50	0	22.22	0.05	20.12	3.00	34.77	PASS
	Highest	QPSK	1	0	24.27	0.05	22.17	3.00	34.77	PASS
			1	24	24.44	0.05	22.34	3.00	34.77	PASS
			1	49	24.08	0.05	21.98	3.00	34.77	PASS
			25	0	23.23	0.05	21.13	3.00	34.77	PASS
			25	12	23.22	0.05	21.12	3.00	34.77	PASS
			25	24	23.21	0.05	21.11	3.00	34.77	PASS
			50	0	23.17	0.05	21.07	3.00	34.77	PASS
		16QAM	1	0	23.20	0.05	21.10	3.00	34.77	PASS
1			24	23.16	0.05	21.06	3.00	34.77	PASS	
1			49	23.21	0.05	21.11	3.00	34.77	PASS	
25			0	22.27	0.05	20.17	3.00	34.77	PASS	
25			12	22.28	0.05	20.18	3.00	34.77	PASS	
25			24	22.21	0.05	20.11	3.00	34.77	PASS	
50			0	22.27	0.05	20.17	3.00	34.77	PASS	



Radiated Power (ERP) for LTE Band 26(Part 22) /1.4M										
BW (MHz)	UL Channel	RB Size	RB offset	Modulation	Conduction AVG Power(dBm)	Ant Gain (dBi)	ERP (dBm)	ERP Limit(W)	ERP Limit(dBm)	Verdict
1.4	Lowest	1	0	QPSK	23.69	0.05	21.59	7.00	38.45	PASS
		1	2		23.85	0.05	21.75	7.00	38.45	PASS
		1	5		23.68	0.05	21.58	7.00	38.45	PASS
		3	0		23.59	0.05	21.49	7.00	38.45	PASS
		3	1		23.59	0.05	21.49	7.00	38.45	PASS
		3	2		23.61	0.05	21.51	7.00	38.45	PASS
		6	0		22.66	0.05	20.56	7.00	38.45	PASS
		1	0	16QAM	22.64	0.05	20.54	7.00	38.45	PASS
		1	2		22.77	0.05	20.67	7.00	38.45	PASS
		1	5		22.65	0.05	20.55	7.00	38.45	PASS
		3	0		22.75	0.05	20.65	7.00	38.45	PASS
		3	1		22.76	0.05	20.66	7.00	38.45	PASS
		3	2		22.73	0.05	20.63	7.00	38.45	PASS
		6	0		21.74	0.05	19.64	7.00	38.45	PASS
	Middle	QPSK	1	0	23.60	0.05	21.50	7.00	38.45	PASS
			1	2	23.76	0.05	21.66	7.00	38.45	PASS
			1	5	23.58	0.05	21.48	7.00	38.45	PASS
			3	0	23.69	0.05	21.59	7.00	38.45	PASS
			3	1	23.68	0.05	21.58	7.00	38.45	PASS
			3	2	23.67	0.05	21.57	7.00	38.45	PASS
			6	0	22.69	0.05	20.59	7.00	38.45	PASS
		16QAM	1	0	22.72	0.05	20.62	7.00	38.45	PASS
			1	2	22.78	0.05	20.68	7.00	38.45	PASS
			1	5	22.71	0.05	20.61	7.00	38.45	PASS
			3	0	22.82	0.05	20.72	7.00	38.45	PASS
			3	1	22.85	0.05	20.75	7.00	38.45	PASS
			3	2	22.82	0.05	20.72	7.00	38.45	PASS
			6	0	21.74	0.05	19.64	7.00	38.45	PASS
	Highest	QPSK	1	0	23.66	0.05	21.56	7.00	38.45	PASS
			1	2	23.84	0.05	21.74	7.00	38.45	PASS
			1	5	23.66	0.05	21.56	7.00	38.45	PASS
			3	0	23.61	0.05	21.51	7.00	38.45	PASS
			3	1	23.62	0.05	21.52	7.00	38.45	PASS
			3	2	23.58	0.05	21.48	7.00	38.45	PASS
			6	0	22.68	0.05	20.58	7.00	38.45	PASS
		16QAM	1	0	22.33	0.05	20.23	7.00	38.45	PASS
1			2	22.47	0.05	20.37	7.00	38.45	PASS	
1			5	22.31	0.05	20.21	7.00	38.45	PASS	
3			0	22.66	0.05	20.56	7.00	38.45	PASS	
3			1	22.66	0.05	20.56	7.00	38.45	PASS	
3			2	22.67	0.05	20.57	7.00	38.45	PASS	
6			0	21.75	0.05	19.65	7.00	38.45	PASS	



Radiated Power (ERP) for LTE Band 26(Part 22) /3M										
BW (MHz)	UL Channel	RB Size	RB offset	Modulation	Conduction AVG Power(dBm)	Ant Gain (dBi)	ERP (dBm)	ERP Limit(W)	ERP Limit(dBm)	Verdict
3	Lowest	1	0	QPSK	23.58	0.05	21.48	7.00	38.45	PASS
		1	7		23.90	0.05	21.80	7.00	38.45	PASS
		1	14		23.61	0.05	21.51	7.00	38.45	PASS
		8	0		22.60	0.05	20.50	7.00	38.45	PASS
		8	4		22.64	0.05	20.54	7.00	38.45	PASS
		8	7		22.64	0.05	20.54	7.00	38.45	PASS
		15	0		22.54	0.05	20.44	7.00	38.45	PASS
		1	0	16QAM	22.92	0.05	20.82	7.00	38.45	PASS
		1	7		23.19	0.05	21.09	7.00	38.45	PASS
		1	14		22.92	0.05	20.82	7.00	38.45	PASS
		8	0		21.56	0.05	19.46	7.00	38.45	PASS
		8	4		21.58	0.05	19.48	7.00	38.45	PASS
		8	7		21.57	0.05	19.47	7.00	38.45	PASS
		15	0		21.51	0.05	19.41	7.00	38.45	PASS
		Middle	QPSK	1	0	23.78	0.05	21.68	7.00	38.45
	1			7	24.04	0.05	21.94	7.00	38.45	PASS
	1			14	23.78	0.05	21.68	7.00	38.45	PASS
	8			0	22.67	0.05	20.57	7.00	38.45	PASS
	8			4	22.68	0.05	20.58	7.00	38.45	PASS
	8			7	22.66	0.05	20.56	7.00	38.45	PASS
	15			0	22.64	0.05	20.54	7.00	38.45	PASS
	16QAM		1	0	22.48	0.05	20.38	7.00	38.45	PASS
			1	7	22.72	0.05	20.62	7.00	38.45	PASS
			1	14	22.44	0.05	20.34	7.00	38.45	PASS
			8	0	21.57	0.05	19.47	7.00	38.45	PASS
			8	4	21.59	0.05	19.49	7.00	38.45	PASS
			8	7	21.60	0.05	19.50	7.00	38.45	PASS
			15	0	21.66	0.05	19.56	7.00	38.45	PASS
			Highest	QPSK	1	0	23.63	0.05	21.53	7.00
	1	7			23.82	0.05	21.72	7.00	38.45	PASS
	1	14			23.63	0.05	21.53	7.00	38.45	PASS
	8	0			22.64	0.05	20.54	7.00	38.45	PASS
	8	4			22.64	0.05	20.54	7.00	38.45	PASS
	8	7			22.62	0.05	20.52	7.00	38.45	PASS
	15	0			22.54	0.05	20.44	7.00	38.45	PASS
	16QAM	1		0	22.89	0.05	20.79	7.00	38.45	PASS
1		7		23.19	0.05	21.09	7.00	38.45	PASS	
1		14		22.83	0.05	20.73	7.00	38.45	PASS	
8		0		21.59	0.05	19.49	7.00	38.45	PASS	
8		4		21.60	0.05	19.50	7.00	38.45	PASS	
8		7		21.56	0.05	19.46	7.00	38.45	PASS	
15		0		21.52	0.05	19.42	7.00	38.45	PASS	



Radiated Power (ERP) for LTE Band 26(Part 22) /5M										
BW (MHz)	UL Channel	RB Size	RB offset	Modulation	Conduction AVG Power(dBm)	Ant Gain (dBi)	ERP (dBm)	ERP Limit(W)	ERP Limit(dBm)	Verdict
5	Lowest	1	0	QPSK	24.17	0.05	22.07	7.00	38.45	PASS
		1	12		24.57	0.05	22.47	7.00	38.45	PASS
		1	24		24.25	0.05	22.15	7.00	38.45	PASS
		12	0		23.18	0.05	21.08	7.00	38.45	PASS
		12	6		23.22	0.05	21.12	7.00	38.45	PASS
		12	11		23.17	0.05	21.07	7.00	38.45	PASS
		25	0		23.16	0.05	21.06	7.00	38.45	PASS
		1	0	16QAM	23.28	0.05	21.18	7.00	38.45	PASS
		1	12		23.55	0.05	21.45	7.00	38.45	PASS
		1	24		23.35	0.05	21.25	7.00	38.45	PASS
		12	0		22.09	0.05	19.99	7.00	38.45	PASS
		12	6		22.12	0.05	20.02	7.00	38.45	PASS
		12	11		22.10	0.05	20.00	7.00	38.45	PASS
		25	0		22.10	0.05	20.00	7.00	38.45	PASS
	Middle	QPSK	1	0	24.12	0.05	22.02	7.00	38.45	PASS
			1	12	24.37	0.05	22.27	7.00	38.45	PASS
			1	24	24.10	0.05	22.00	7.00	38.45	PASS
			12	0	23.20	0.05	21.10	7.00	38.45	PASS
			12	6	23.25	0.05	21.15	7.00	38.45	PASS
			12	11	23.19	0.05	21.09	7.00	38.45	PASS
			25	0	23.22	0.05	21.12	7.00	38.45	PASS
		16QAM	1	0	23.34	0.05	21.24	7.00	38.45	PASS
			1	12	23.65	0.05	21.55	7.00	38.45	PASS
			1	24	23.30	0.05	21.20	7.00	38.45	PASS
			12	0	22.18	0.05	20.08	7.00	38.45	PASS
			12	6	22.24	0.05	20.14	7.00	38.45	PASS
			12	11	22.16	0.05	20.06	7.00	38.45	PASS
			25	0	22.13	0.05	20.03	7.00	38.45	PASS
	Highest	QPSK	1	0	24.18	0.05	22.08	7.00	38.45	PASS
			1	12	24.57	0.05	22.47	7.00	38.45	PASS
1			24	24.09	0.05	21.99	7.00	38.45	PASS	
12			0	23.14	0.05	21.04	7.00	38.45	PASS	
12			6	23.16	0.05	21.06	7.00	38.45	PASS	
12			11	23.09	0.05	20.99	7.00	38.45	PASS	
25			0	23.14	0.05	21.04	7.00	38.45	PASS	
16QAM		1	0	23.43	0.05	21.33	7.00	38.45	PASS	
		1	12	23.77	0.05	21.67	7.00	38.45	PASS	
		1	24	23.38	0.05	21.28	7.00	38.45	PASS	
		12	0	22.06	0.05	19.96	7.00	38.45	PASS	
		12	6	22.11	0.05	20.01	7.00	38.45	PASS	
		12	11	22.03	0.05	19.93	7.00	38.45	PASS	
		25	0	22.04	0.05	19.94	7.00	38.45	PASS	



Radiated Power (ERP) for LTE Band 26(Part 22) /10M										
BW (MHz)	UL Channel	RB Size	RB offset	Modulation	Conduction AVG Power(dBm)	Ant Gain (dBi)	ERP (dBm)	ERP Limit(W)	ERP Limit(dBm)	Verdict
10	Lowest	1	0	QPSK	24.14	0.05	22.04	7.00	38.45	PASS
		1	24		24.34	0.05	22.24	7.00	38.45	PASS
		1	49		24.25	0.05	22.15	7.00	38.45	PASS
		25	0		23.24	0.05	21.14	7.00	38.45	PASS
		25	12		23.21	0.05	21.11	7.00	38.45	PASS
		25	24		23.26	0.05	21.16	7.00	38.45	PASS
		50	0		23.23	0.05	21.13	7.00	38.45	PASS
		1	0	16QAM	23.38	0.05	21.28	7.00	38.45	PASS
		1	24		23.56	0.05	21.46	7.00	38.45	PASS
		1	49		23.51	0.05	21.41	7.00	38.45	PASS
		25	0		22.19	0.05	20.09	7.00	38.45	PASS
		25	12		22.15	0.05	20.05	7.00	38.45	PASS
		25	24		22.21	0.05	20.11	7.00	38.45	PASS
		50	0		22.20	0.05	20.10	7.00	38.45	PASS
	Middle	QPSK	1	0	24.22	0.05	22.12	7.00	38.45	PASS
			1	24	24.34	0.05	22.24	7.00	38.45	PASS
			1	49	24.25	0.05	22.15	7.00	38.45	PASS
			25	0	23.21	0.05	21.11	7.00	38.45	PASS
			25	12	23.22	0.05	21.12	7.00	38.45	PASS
			25	24	23.20	0.05	21.10	7.00	38.45	PASS
			50	0	23.18	0.05	21.08	7.00	38.45	PASS
		16QAM	1	0	23.21	0.05	21.11	7.00	38.45	PASS
			1	24	23.36	0.05	21.26	7.00	38.45	PASS
			1	49	23.23	0.05	21.13	7.00	38.45	PASS
			25	0	22.18	0.05	20.08	7.00	38.45	PASS
			25	12	22.16	0.05	20.06	7.00	38.45	PASS
			25	24	22.11	0.05	20.01	7.00	38.45	PASS
			50	0	22.19	0.05	20.09	7.00	38.45	PASS
	Highest	QPSK	1	0	24.33	0.05	22.23	7.00	38.45	PASS
			1	24	24.47	0.05	22.37	7.00	38.45	PASS
			1	49	24.30	0.05	22.20	7.00	38.45	PASS
			25	0	23.25	0.05	21.15	7.00	38.45	PASS
			25	12	23.16	0.05	21.06	7.00	38.45	PASS
			25	24	23.10	0.05	21.00	7.00	38.45	PASS
			50	0	23.16	0.05	21.06	7.00	38.45	PASS
		16QAM	1	0	22.91	0.05	20.81	7.00	38.45	PASS
1			24	23.02	0.05	20.92	7.00	38.45	PASS	
1			49	22.85	0.05	20.75	7.00	38.45	PASS	
25			0	22.18	0.05	20.08	7.00	38.45	PASS	
25			12	22.06	0.05	19.96	7.00	38.45	PASS	
25			24	22.05	0.05	19.95	7.00	38.45	PASS	
50			0	22.07	0.05	19.97	7.00	38.45	PASS	





Radiated Power (ERP) for LTE Band 26(Part 22) /15M										
BW (MHz)	UL Channel	RB Size	RB offset	Modulation	Conduction AVG Power(dBm)	Ant Gain (dBi)	ERP (dBm)	ERP Limit(W)	ERP Limit(dBm)	Verdict
15	Lowest	1	0	QPSK	24.05	0.05	21.95	7.00	38.45	PASS
		1	24		24.54	0.05	22.44	7.00	38.45	PASS
		1	49		24.17	0.05	22.07	7.00	38.45	PASS
		25	0		23.28	0.05	21.18	7.00	38.45	PASS
		25	12		23.33	0.05	21.23	7.00	38.45	PASS
		25	24		23.35	0.05	21.25	7.00	38.45	PASS
		50	0		23.34	0.05	21.24	7.00	38.45	PASS
		1	0	16QAM	23.06	0.05	20.96	7.00	38.45	PASS
		1	24		23.46	0.05	21.36	7.00	38.45	PASS
		1	49		23.19	0.05	21.09	7.00	38.45	PASS
		25	0		22.14	0.05	20.04	7.00	38.45	PASS
		25	12		22.21	0.05	20.11	7.00	38.45	PASS
		25	24		22.21	0.05	20.11	7.00	38.45	PASS
		50	0		22.28	0.05	20.18	7.00	38.45	PASS
	Middle	1	0	QPSK	24.09	0.05	21.99	7.00	38.45	PASS
		1	24		24.43	0.05	22.33	7.00	38.45	PASS
		1	49		24.16	0.05	22.06	7.00	38.45	PASS
		25	0		23.31	0.05	21.21	7.00	38.45	PASS
		25	12		23.38	0.05	21.28	7.00	38.45	PASS
		25	24		23.33	0.05	21.23	7.00	38.45	PASS
		50	0		23.34	0.05	21.24	7.00	38.45	PASS
		1	0	16QAM	23.34	0.05	21.24	7.00	38.45	PASS
		1	24		23.67	0.05	21.57	7.00	38.45	PASS
		1	49		23.37	0.05	21.27	7.00	38.45	PASS
		25	0		22.22	0.05	20.12	7.00	38.45	PASS
		25	12		22.28	0.05	20.18	7.00	38.45	PASS
		25	24		22.23	0.05	20.13	7.00	38.45	PASS
		50	0		22.20	0.05	20.10	7.00	38.45	PASS
	Highest	1	0	QPSK	24.16	0.05	22.06	7.00	38.45	PASS
		1	24		24.59	0.05	22.49	7.00	38.45	PASS
		1	49		24.09	0.05	21.99	7.00	38.45	PASS
		25	0		23.34	0.05	21.24	7.00	38.45	PASS
		25	12		23.39	0.05	21.29	7.00	38.45	PASS
		25	24		23.30	0.05	21.20	7.00	38.45	PASS
		50	0		23.35	0.05	21.25	7.00	38.45	PASS
		1	0	16QAM	23.18	0.05	21.08	7.00	38.45	PASS
1		24	23.52		0.05	21.42	7.00	38.45	PASS	
1		49	23.06		0.05	20.96	7.00	38.45	PASS	
25		0	22.31		0.05	20.21	7.00	38.45	PASS	
25		12	22.27		0.05	20.17	7.00	38.45	PASS	
25		24	22.26		0.05	20.16	7.00	38.45	PASS	
50		0	22.22		0.05	20.12	7.00	38.45	PASS	





Radiated Power (ERP) for LTE Band 26(Part 90) /1.4M											
BW (MHz)	UL Channel	RB Size	RB offset	Modulation	Conduction AVG Power(dBm)	Ant Gain (dBi)	ERP (dBm)	ERP Limit(W)	ERP Limit(dBm)	Verdict	
1.4	Lowest	1	0	QPSK	24.14	0.05	22.04	100.00	50.00	PASS	
		1	2		24.29	0.05	22.19	100.00	50.00	PASS	
		1	5		24.11	0.05	22.01	100.00	50.00	PASS	
		3	0		24.18	0.05	22.08	100.00	50.00	PASS	
		3	1		24.22	0.05	22.12	100.00	50.00	PASS	
		3	2		24.21	0.05	22.11	100.00	50.00	PASS	
		6	0	23.17	0.05	21.07	100.00	50.00	PASS		
		1	0	16QAM	23.23	0.05	21.13	100.00	50.00	PASS	
		1	2		23.37	0.05	21.27	100.00	50.00	PASS	
		1	5		23.27	0.05	21.17	100.00	50.00	PASS	
		3	0		23.38	0.05	21.28	100.00	50.00	PASS	
		3	1		23.38	0.05	21.28	100.00	50.00	PASS	
		3	2		23.37	0.05	21.27	100.00	50.00	PASS	
		6	0	22.31	0.05	20.21	100.00	50.00	PASS		
		Middle	QPSK	1	0	24.17	0.05	22.07	100.00	50.00	PASS
				1	2	24.35	0.05	22.25	100.00	50.00	PASS
				1	5	24.19	0.05	22.09	100.00	50.00	PASS
				3	0	24.12	0.05	22.02	100.00	50.00	PASS
	3			1	24.16	0.05	22.06	100.00	50.00	PASS	
	3			2	24.10	0.05	22.00	100.00	50.00	PASS	
	6		0	23.19	0.05	21.09	100.00	50.00	PASS		
	16QAM		1	0	22.86	0.05	20.76	100.00	50.00	PASS	
			1	2	23.02	0.05	20.92	100.00	50.00	PASS	
			1	5	22.84	0.05	20.74	100.00	50.00	PASS	
			3	0	23.19	0.05	21.09	100.00	50.00	PASS	
			3	1	23.23	0.05	21.13	100.00	50.00	PASS	
			3	2	23.21	0.05	21.11	100.00	50.00	PASS	
	6		0	22.26	0.05	20.16	100.00	50.00	PASS		
	Highest		QPSK	1	0	24.24	0.05	22.14	100.00	50.00	PASS
				1	2	24.39	0.05	22.29	100.00	50.00	PASS
				1	5	24.21	0.05	22.11	100.00	50.00	PASS
				3	0	24.08	0.05	21.98	100.00	50.00	PASS
		3		1	24.14	0.05	22.04	100.00	50.00	PASS	
		3		2	24.11	0.05	22.01	100.00	50.00	PASS	
		6	0	23.22	0.05	21.12	100.00	50.00	PASS		
		16QAM	1	0	23.14	0.05	21.04	100.00	50.00	PASS	
			1	2	23.25	0.05	21.15	100.00	50.00	PASS	
			1	5	23.14	0.05	21.04	100.00	50.00	PASS	
			3	0	23.26	0.05	21.16	100.00	50.00	PASS	
			3	1	23.27	0.05	21.17	100.00	50.00	PASS	
			3	2	23.24	0.05	21.14	100.00	50.00	PASS	
		6	0	22.25	0.05	20.15	100.00	50.00	PASS		



Radiated Power (ERP) for LTE Band 26(Part 90) /3M										
BW (MHz)	UL Channel	RB Size	RB offset	Modulation	Conduction AVG Power(dBm)	Ant Gain (dBi)	ERP (dBm)	ERP Limit(W)	ERP Limit(dBm)	Verdict
3	Lowest	1	0	QPSK	24.20	0.05	22.10	100.00	50.00	PASS
		1	7		24.43	0.05	22.33	100.00	50.00	PASS
		1	14		24.15	0.05	22.05	100.00	50.00	PASS
		8	0		23.15	0.05	21.05	100.00	50.00	PASS
		8	4		23.19	0.05	21.09	100.00	50.00	PASS
		8	7		23.21	0.05	21.11	100.00	50.00	PASS
		15	0		23.11	0.05	21.01	100.00	50.00	PASS
		1	0	16QAM	23.56	0.05	21.46	100.00	50.00	PASS
		1	7		23.69	0.05	21.59	100.00	50.00	PASS
		1	14		23.41	0.05	21.31	100.00	50.00	PASS
		8	0		22.10	0.05	20.00	100.00	50.00	PASS
		8	4		22.16	0.05	20.06	100.00	50.00	PASS
		8	7		22.12	0.05	20.02	100.00	50.00	PASS
		15	0		22.08	0.05	19.98	100.00	50.00	PASS
		1	0	QPSK	24.14	0.05	22.04	100.00	50.00	PASS
	1	7	24.36		0.05	22.26	100.00	50.00	PASS	
	1	14	24.15		0.05	22.05	100.00	50.00	PASS	
	8	0	23.14		0.05	21.04	100.00	50.00	PASS	
	8	4	23.16		0.05	21.06	100.00	50.00	PASS	
	8	7	23.15		0.05	21.05	100.00	50.00	PASS	
	15	0	23.11		0.05	21.01	100.00	50.00	PASS	
	1	0	16QAM	23.20	0.05	21.10	100.00	50.00	PASS	
	1	7		23.48	0.05	21.38	100.00	50.00	PASS	
	1	14		23.21	0.05	21.11	100.00	50.00	PASS	
	8	0		22.06	0.05	19.96	100.00	50.00	PASS	
	8	4		22.06	0.05	19.96	100.00	50.00	PASS	
	8	7		22.03	0.05	19.93	100.00	50.00	PASS	
	15	0		21.97	0.05	19.87	100.00	50.00	PASS	
	1	0	QPSK	24.17	0.05	22.07	100.00	50.00	PASS	
	1	7		24.49	0.05	22.39	100.00	50.00	PASS	
	1	14		24.27	0.05	22.17	100.00	50.00	PASS	
	8	0		23.11	0.05	21.01	100.00	50.00	PASS	
	8	4		23.13	0.05	21.03	100.00	50.00	PASS	
	8	7		23.11	0.05	21.01	100.00	50.00	PASS	
	15	0		23.09	0.05	20.99	100.00	50.00	PASS	
	1	0	16QAM	22.91	0.05	20.81	100.00	50.00	PASS	
1	7	23.16		0.05	21.06	100.00	50.00	PASS		
1	14	22.90		0.05	20.80	100.00	50.00	PASS		
8	0	22.03		0.05	19.93	100.00	50.00	PASS		
8	4	22.02		0.05	19.92	100.00	50.00	PASS		
8	7	22.02		0.05	19.92	100.00	50.00	PASS		
15	0	22.06		0.05	19.96	100.00	50.00	PASS		



Radiated Power (ERP) for LTE Band 26(Part 90) /5M										
BW (MHz)	UL Channel	RB Size	RB offset	Modulation	Conduction AVG Power(dBm)	Ant Gain (dBi)	ERP (dBm)	ERP Limit(W)	ERP Limit(dBm)	Verdict
5	Lowest	1	0	QPSK	24.09	0.05	21.99	100.00	50.00	PASS
		1	12		24.54	0.05	22.44	100.00	50.00	PASS
		1	24		24.03	0.05	21.93	100.00	50.00	PASS
		12	0		23.11	0.05	21.01	100.00	50.00	PASS
		12	6		23.21	0.05	21.11	100.00	50.00	PASS
		12	11		23.13	0.05	21.03	100.00	50.00	PASS
		25	0	23.16	0.05	21.06	100.00	50.00	PASS	
		1	0	16QAM	23.33	0.05	21.23	100.00	50.00	PASS
		1	12		23.63	0.05	21.53	100.00	50.00	PASS
		1	24		23.23	0.05	21.13	100.00	50.00	PASS
		12	0		22.08	0.05	19.98	100.00	50.00	PASS
		12	6		22.19	0.05	20.09	100.00	50.00	PASS
		12	11		22.12	0.05	20.02	100.00	50.00	PASS
		25	0	22.07	0.05	19.97	100.00	50.00	PASS	
		Middle	QPSK	1	0	24.08	0.05	21.98	100.00	50.00
	1			12	24.34	0.05	22.24	100.00	50.00	PASS
	1			24	24.07	0.05	21.97	100.00	50.00	PASS
	12			0	23.09	0.05	20.99	100.00	50.00	PASS
	12			6	23.15	0.05	21.05	100.00	50.00	PASS
	12			11	23.07	0.05	20.97	100.00	50.00	PASS
	25		0	23.11	0.05	21.01	100.00	50.00	PASS	
	16QAM		1	0	23.45	0.05	21.35	100.00	50.00	PASS
			1	12	23.71	0.05	21.61	100.00	50.00	PASS
			1	24	23.48	0.05	21.38	100.00	50.00	PASS
			12	0	22.04	0.05	19.94	100.00	50.00	PASS
			12	6	22.08	0.05	19.98	100.00	50.00	PASS
			12	11	22.01	0.05	19.91	100.00	50.00	PASS
	25		0	21.99	0.05	19.89	100.00	50.00	PASS	
	Highest		QPSK	1	0	24.10	0.05	22.00	100.00	50.00
		1		12	24.45	0.05	22.35	100.00	50.00	PASS
		1		24	24.12	0.05	22.02	100.00	50.00	PASS
		12		0	23.03	0.05	20.93	100.00	50.00	PASS
		12		6	23.12	0.05	21.02	100.00	50.00	PASS
		12		11	23.05	0.05	20.95	100.00	50.00	PASS
		25	0	23.10	0.05	21.00	100.00	50.00	PASS	
		16QAM	1	0	23.23	0.05	21.13	100.00	50.00	PASS
			1	12	23.57	0.05	21.47	100.00	50.00	PASS
			1	24	23.28	0.05	21.18	100.00	50.00	PASS
			12	0	21.97	0.05	19.87	100.00	50.00	PASS
			12	6	22.06	0.05	19.96	100.00	50.00	PASS
			12	11	21.96	0.05	19.86	100.00	50.00	PASS
		25	0	22.08	0.05	19.98	100.00	50.00	PASS	



Radiated Power (ERP) for LTE Band 26(Part 90) /10M										
BW (MHz)	UL Channel	RB Size	RB offset	Modulation	Conduction AVG Power(dBm)	Ant Gain (dBi)	ERP (dBm)	ERP Limit(W)	ERP Limit(dBm)	Verdict
10	Middle	1	0	QPSK	24.14	0.05	22.04	100.00	50.00	PASS
		1	24		24.59	0.05	22.49	100.00	50.00	PASS
		1	49		24.13	0.05	22.03	100.00	50.00	PASS
		25	0		23.16	0.05	21.06	100.00	50.00	PASS
		25	12		23.11	0.05	21.01	100.00	50.00	PASS
		25	24		23.14	0.05	21.04	100.00	50.00	PASS
		50	0		23.12	0.05	21.02	100.00	50.00	PASS
		1	0	16QAM	23.47	0.05	21.37	100.00	50.00	PASS
		1	24		23.50	0.05	21.40	100.00	50.00	PASS
		1	49		23.41	0.05	21.31	100.00	50.00	PASS
		25	0		22.10	0.05	20.00	100.00	50.00	PASS
		25	12		22.08	0.05	19.98	100.00	50.00	PASS
		25	24		22.09	0.05	19.99	100.00	50.00	PASS
		50	0		22.08	0.05	19.98	100.00	50.00	PASS





Radiated Power (EIRP) for LTE Band 41 /5M										
BW (MHz)	UL Channel	RB Size	RB offset	Modulation	Conduction AVG Power(dBm)	Ant Gain (dBi)	EIRP (dBm)	EIRP Limit(W)	EIRP Limit(dBm)	Verdict
5	Lowest	1	0	QPSK	21.74	0.23	21.97	2.00	33.01	PASS
		1	12		21.98	0.23	22.21	2.00	33.01	PASS
		1	24		21.69	0.23	21.92	2.00	33.01	PASS
		12	0		20.59	0.23	20.82	2.00	33.01	PASS
		12	6		20.65	0.23	20.88	2.00	33.01	PASS
		12	11		20.54	0.23	20.77	2.00	33.01	PASS
		25	0		20.58	0.23	20.81	2.00	33.01	PASS
		1	0	16QAM	20.84	0.23	21.07	2.00	33.01	PASS
		1	12		20.94	0.23	21.17	2.00	33.01	PASS
		1	24		20.68	0.23	20.91	2.00	33.01	PASS
		12	0		19.44	0.23	19.67	2.00	33.01	PASS
		12	6		19.56	0.23	19.79	2.00	33.01	PASS
		12	11		19.47	0.23	19.70	2.00	33.01	PASS
		25	0		19.52	0.23	19.75	2.00	33.01	PASS
	Middle	QPSK	1	0	21.56	0.23	21.79	2.00	33.01	PASS
			1	12	21.81	0.23	22.04	2.00	33.01	PASS
			1	24	21.48	0.23	21.71	2.00	33.01	PASS
			12	0	20.56	0.23	20.79	2.00	33.01	PASS
			12	6	20.53	0.23	20.76	2.00	33.01	PASS
			12	11	20.47	0.23	20.70	2.00	33.01	PASS
			25	0	20.50	0.23	20.73	2.00	33.01	PASS
		16QAM	1	0	20.67	0.23	20.90	2.00	33.01	PASS
			1	12	20.91	0.23	21.14	2.00	33.01	PASS
			1	24	20.59	0.23	20.82	2.00	33.01	PASS
			12	0	19.46	0.23	19.69	2.00	33.01	PASS
			12	6	19.47	0.23	19.70	2.00	33.01	PASS
			12	11	19.45	0.23	19.68	2.00	33.01	PASS
			25	0	19.34	0.23	19.57	2.00	33.01	PASS
	Highest	QPSK	1	0	20.89	0.23	21.12	2.00	33.01	PASS
			1	12	21.18	0.23	21.41	2.00	33.01	PASS
1			24	20.93	0.23	21.16	2.00	33.01	PASS	
12			0	19.86	0.23	20.09	2.00	33.01	PASS	
12			6	19.91	0.23	20.14	2.00	33.01	PASS	
12			11	19.90	0.23	20.13	2.00	33.01	PASS	
25			0	19.89	0.23	20.12	2.00	33.01	PASS	
16QAM		1	0	20.34	0.23	20.57	2.00	33.01	PASS	
		1	12	20.57	0.23	20.80	2.00	33.01	PASS	
		1	24	20.31	0.23	20.54	2.00	33.01	PASS	
		12	0	18.85	0.23	19.08	2.00	33.01	PASS	
		12	6	18.87	0.23	19.10	2.00	33.01	PASS	
		12	11	18.82	0.23	19.05	2.00	33.01	PASS	
		25	0	18.83	0.23	19.06	2.00	33.01	PASS	





Radiated Power (EIRP) for LTE Band 41 /10M										
BW (MHz)	UL Channel	RB Size	RB offset	Modulation	Conduction AVG Power(dBm)	Ant Gain (dBi)	EIRP (dBm)	EIRP Limit(W)	EIRP Limit(dBm)	Verdict
10	Lowest	1	0	QPSK	21.79	0.23	22.02	2.00	33.01	PASS
		1	24		21.86	0.23	22.09	2.00	33.01	PASS
		1	49		21.72	0.23	21.95	2.00	33.01	PASS
		25	0		20.64	0.23	20.87	2.00	33.01	PASS
		25	12		20.65	0.23	20.88	2.00	33.01	PASS
		25	24		20.62	0.23	20.85	2.00	33.01	PASS
		50	0		20.60	0.23	20.83	2.00	33.01	PASS
		1	0	16QAM	20.99	0.23	21.22	2.00	33.01	PASS
		1	24		21.06	0.23	21.29	2.00	33.01	PASS
		1	49		20.93	0.23	21.16	2.00	33.01	PASS
		25	0		19.56	0.23	19.79	2.00	33.01	PASS
		25	12		19.60	0.23	19.83	2.00	33.01	PASS
		25	24		19.54	0.23	19.77	2.00	33.01	PASS
		50	0		19.54	0.23	19.77	2.00	33.01	PASS
	Middle	1	0	QPSK	21.75	0.23	21.98	2.00	33.01	PASS
		1	24		21.82	0.23	22.05	2.00	33.01	PASS
		1	49		21.62	0.23	21.85	2.00	33.01	PASS
		25	0		20.60	0.23	20.83	2.00	33.01	PASS
		25	12		20.52	0.23	20.75	2.00	33.01	PASS
		25	24		20.57	0.23	20.80	2.00	33.01	PASS
		50	0		20.53	0.23	20.76	2.00	33.01	PASS
		1	0	16QAM	20.62	0.23	20.85	2.00	33.01	PASS
		1	24		20.71	0.23	20.94	2.00	33.01	PASS
		1	49		20.51	0.23	20.74	2.00	33.01	PASS
		25	0		19.47	0.23	19.70	2.00	33.01	PASS
		25	12		19.42	0.23	19.65	2.00	33.01	PASS
		25	24		19.47	0.23	19.70	2.00	33.01	PASS
		50	0		19.45	0.23	19.68	2.00	33.01	PASS
	Highest	1	0	QPSK	21.02	0.23	21.25	2.00	33.01	PASS
		1	24		21.12	0.23	21.35	2.00	33.01	PASS
		1	49		20.97	0.23	21.20	2.00	33.01	PASS
		25	0		19.94	0.23	20.17	2.00	33.01	PASS
		25	12		19.91	0.23	20.14	2.00	33.01	PASS
		25	24		19.92	0.23	20.15	2.00	33.01	PASS
		50	0		19.92	0.23	20.15	2.00	33.01	PASS
		1	0	16QAM	19.85	0.23	20.08	2.00	33.01	PASS
1		24	19.92		0.23	20.15	2.00	33.01	PASS	
1		49	19.81		0.23	20.04	2.00	33.01	PASS	
25		0	18.90		0.23	19.13	2.00	33.01	PASS	
25		12	18.86		0.23	19.09	2.00	33.01	PASS	
25		24	18.84		0.23	19.07	2.00	33.01	PASS	
50		0	18.89		0.23	19.12	2.00	33.01	PASS	





Radiated Power (EIRP) for LTE Band 41 /15M										
BW (MHz)	UL Channel	RB Size	RB offset	Modulation	Conduction AVG Power(dBm)	Ant Gain (dBi)	EIRP (dBm)	EIRP Limit(W)	EIRP Limit(dBm)	Verdict
15	Lowest	1	0	QPSK	21.73	0.23	21.96	2.00	33.01	PASS
		1	37		21.99	0.23	22.22	2.00	33.01	PASS
		1	74		21.64	0.23	21.87	2.00	33.01	PASS
		36	0		20.77	0.23	21.00	2.00	33.01	PASS
		36	18		20.79	0.23	21.02	2.00	33.01	PASS
		36	39		20.76	0.23	20.99	2.00	33.01	PASS
		75	0	20.79	0.23	21.02	2.00	33.01	PASS	
		1	0	16QAM	20.92	0.23	21.15	2.00	33.01	PASS
		1	37		21.18	0.23	21.41	2.00	33.01	PASS
		1	74		20.84	0.23	21.07	2.00	33.01	PASS
		36	0		19.72	0.23	19.95	2.00	33.01	PASS
		36	18		19.72	0.23	19.95	2.00	33.01	PASS
	36	39	19.69		0.23	19.92	2.00	33.01	PASS	
	75	0	19.60	0.23	19.83	2.00	33.01	PASS		
	1	0	QPSK	21.70	0.23	21.93	2.00	33.01	PASS	
	1	37		21.97	0.23	22.20	2.00	33.01	PASS	
	1	74		21.52	0.23	21.75	2.00	33.01	PASS	
	36	0		20.72	0.23	20.95	2.00	33.01	PASS	
	36	18		20.70	0.23	20.93	2.00	33.01	PASS	
	36	39		20.66	0.23	20.89	2.00	33.01	PASS	
	75	0	20.68	0.23	20.91	2.00	33.01	PASS		
	1	0	16QAM	20.56	0.23	20.79	2.00	33.01	PASS	
	1	37		20.83	0.23	21.06	2.00	33.01	PASS	
	1	74		20.45	0.23	20.68	2.00	33.01	PASS	
	36	0		19.69	0.23	19.92	2.00	33.01	PASS	
	36	18		19.64	0.23	19.87	2.00	33.01	PASS	
	36	39		19.60	0.23	19.83	2.00	33.01	PASS	
	75	0	19.56	0.23	19.79	2.00	33.01	PASS		
	1	0	QPSK	21.16	0.23	21.39	2.00	33.01	PASS	
	1	37		21.39	0.23	21.62	2.00	33.01	PASS	
	1	74		21.03	0.23	21.26	2.00	33.01	PASS	
	36	0		20.08	0.23	20.31	2.00	33.01	PASS	
	36	18		20.01	0.23	20.24	2.00	33.01	PASS	
	36	39		19.96	0.23	20.19	2.00	33.01	PASS	
	75	0	20.06	0.23	20.29	2.00	33.01	PASS		
	1	0	16QAM	20.16	0.23	20.39	2.00	33.01	PASS	
1	37	20.35		0.23	20.58	2.00	33.01	PASS		
1	74	20.00		0.23	20.23	2.00	33.01	PASS		
36	0	18.98		0.23	19.21	2.00	33.01	PASS		
36	18	18.98		0.23	19.21	2.00	33.01	PASS		
36	39	18.85		0.23	19.08	2.00	33.01	PASS		
75	0	19.03	0.23	19.26	2.00	33.01	PASS			



Radiated Power (EIRP) for LTE Band 41 /20M										
BW (MHz)	UL Channel	RB Size	RB offset	Modulation	Conduction AVG Power(dBm)	Ant Gain (dBi)	EIRP (dBm)	EIRP Limit(W)	EIRP Limit(dBm)	Verdict
20	Lowest	1	0	QPSK	21.59	0.23	21.82	2.00	33.01	PASS
		1	49		22.05	0.23	22.28	2.00	33.01	PASS
		1	99		21.56	0.23	21.79	2.00	33.01	PASS
		50	0		20.61	0.23	20.84	2.00	33.01	PASS
		50	24		20.62	0.23	20.85	2.00	33.01	PASS
		50	49		20.61	0.23	20.84	2.00	33.01	PASS
		100	0		20.61	0.23	20.84	2.00	33.01	PASS
		1	0	16QAM	20.57	0.23	20.80	2.00	33.01	PASS
		1	49		20.88	0.23	21.11	2.00	33.01	PASS
		1	99		20.51	0.23	20.74	2.00	33.01	PASS
		50	0		19.59	0.23	19.82	2.00	33.01	PASS
		50	24		19.60	0.23	19.83	2.00	33.01	PASS
		50	49		19.55	0.23	19.78	2.00	33.01	PASS
		100	0		19.54	0.23	19.77	2.00	33.01	PASS
	Middle	1	0	QPSK	21.63	0.23	21.86	2.00	33.01	PASS
		1	49		21.91	0.23	22.14	2.00	33.01	PASS
		1	99		21.40	0.23	21.63	2.00	33.01	PASS
		50	0		20.56	0.23	20.79	2.00	33.01	PASS
		50	24		20.52	0.23	20.75	2.00	33.01	PASS
		50	49		20.50	0.23	20.73	2.00	33.01	PASS
		100	0		20.51	0.23	20.74	2.00	33.01	PASS
		1	0	16QAM	20.46	0.23	20.69	2.00	33.01	PASS
		1	49		20.79	0.23	21.02	2.00	33.01	PASS
		1	99		20.33	0.23	20.56	2.00	33.01	PASS
		50	0		19.45	0.23	19.68	2.00	33.01	PASS
		50	24		19.41	0.23	19.64	2.00	33.01	PASS
		50	49		19.41	0.23	19.64	2.00	33.01	PASS
		100	0		19.44	0.23	19.67	2.00	33.01	PASS
	Highest	1	0	QPSK	21.03	0.23	21.26	2.00	33.01	PASS
		1	49		21.26	0.23	21.49	2.00	33.01	PASS
		1	99		20.81	0.23	21.04	2.00	33.01	PASS
		50	0		20.02	0.23	20.25	2.00	33.01	PASS
		50	24		19.91	0.23	20.14	2.00	33.01	PASS
		50	49		19.87	0.23	20.10	2.00	33.01	PASS
		100	0		19.96	0.23	20.19	2.00	33.01	PASS
		1	0	16QAM	19.96	0.23	20.19	2.00	33.01	PASS
1		49	20.22		0.23	20.45	2.00	33.01	PASS	
1		99	19.78		0.23	20.01	2.00	33.01	PASS	
50		0	19.02		0.23	19.25	2.00	33.01	PASS	
50		24	18.92		0.23	19.15	2.00	33.01	PASS	
50		49	18.85		0.23	19.08	2.00	33.01	PASS	
100		0	18.96		0.23	19.19	2.00	33.01	PASS	



Radiated Power (EIRP) for LTE Band 66 /1.4M										
BW (MHz)	UL Channel	RB Size	RB offset	Modulation	Conduction AVG Power(dBm)	Ant Gain (dBi)	EIRP (dBm)	EIRP Limit(W)	EIRP Limit(dBm)	Verdict
1.4	Lowest	1	0	QPSK	23.13	0.26	23.39	1.00	30.00	PASS
		1	2		23.27	0.26	23.53	1.00	30.00	PASS
		1	5		23.10	0.26	23.36	1.00	30.00	PASS
		3	0		23.20	0.26	23.46	1.00	30.00	PASS
		3	1		23.23	0.26	23.49	1.00	30.00	PASS
		3	2		23.20	0.26	23.46	1.00	30.00	PASS
		6	0		22.12	0.26	22.38	1.00	30.00	PASS
		1	0	16QAM	22.21	0.26	22.47	1.00	30.00	PASS
		1	2		22.36	0.26	22.62	1.00	30.00	PASS
		1	5		22.27	0.26	22.53	1.00	30.00	PASS
		3	0		22.37	0.26	22.63	1.00	30.00	PASS
		3	1		22.39	0.26	22.65	1.00	30.00	PASS
		3	2		22.41	0.26	22.67	1.00	30.00	PASS
		6	0		21.26	0.26	21.52	1.00	30.00	PASS
	Middle	QPSK	1	0	22.98	0.26	23.24	1.00	30.00	PASS
			1	2	23.12	0.26	23.38	1.00	30.00	PASS
			1	5	22.97	0.26	23.23	1.00	30.00	PASS
			3	0	22.89	0.26	23.15	1.00	30.00	PASS
			3	1	22.93	0.26	23.19	1.00	30.00	PASS
			3	2	22.91	0.26	23.17	1.00	30.00	PASS
			6	0	21.95	0.26	22.21	1.00	30.00	PASS
		16QAM	1	0	21.59	0.26	21.85	1.00	30.00	PASS
			1	2	21.80	0.26	22.06	1.00	30.00	PASS
			1	5	21.60	0.26	21.86	1.00	30.00	PASS
			3	0	22.01	0.26	22.27	1.00	30.00	PASS
			3	1	22.00	0.26	22.26	1.00	30.00	PASS
			3	2	22.04	0.26	22.30	1.00	30.00	PASS
			6	0	21.05	0.26	21.31	1.00	30.00	PASS
	Highest	QPSK	1	0	22.70	0.26	22.96	1.00	30.00	PASS
			1	2	22.83	0.26	23.09	1.00	30.00	PASS
			1	5	22.66	0.26	22.92	1.00	30.00	PASS
			3	0	22.71	0.26	22.97	1.00	30.00	PASS
			3	1	22.70	0.26	22.96	1.00	30.00	PASS
			3	2	22.64	0.26	22.90	1.00	30.00	PASS
			6	0	21.80	0.26	22.06	1.00	30.00	PASS
		16QAM	1	0	21.70	0.26	21.96	1.00	30.00	PASS
1			2	21.84	0.26	22.10	1.00	30.00	PASS	
1			5	21.72	0.26	21.98	1.00	30.00	PASS	
3			0	21.78	0.26	22.04	1.00	30.00	PASS	
3			1	21.79	0.26	22.05	1.00	30.00	PASS	
3			2	21.76	0.26	22.02	1.00	30.00	PASS	
6			0	20.78	0.26	21.04	1.00	30.00	PASS	



Radiated Power (EIRP) for LTE Band 66 /3M										
BW (MHz)	UL Channel	RB Size	RB offset	Modulation	Conduction AVG Power(dBm)	Ant Gain (dBi)	EIRP (dBm)	EIRP Limit(W)	EIRP Limit(dBm)	Verdict
3	Lowest	1	0	QPSK	24.05	0.26	24.31	1.00	30.00	PASS
		1	7		24.05	0.26	24.31	1.00	30.00	PASS
		1	14		23.98	0.26	24.24	1.00	30.00	PASS
		8	0		23.93	0.26	24.19	1.00	30.00	PASS
		8	4		23.84	0.26	24.10	1.00	30.00	PASS
		8	7		23.83	0.26	24.09	1.00	30.00	PASS
		15	0		23.64	0.26	23.90	1.00	30.00	PASS
		1	0	16QAM	24.11	0.26	24.37	1.00	30.00	PASS
		1	7		23.87	0.26	24.13	1.00	30.00	PASS
		1	14		23.90	0.26	24.16	1.00	30.00	PASS
		8	0		23.80	0.26	24.06	1.00	30.00	PASS
		8	4		23.67	0.26	23.93	1.00	30.00	PASS
		8	7		23.73	0.26	23.99	1.00	30.00	PASS
		15	0		23.50	0.26	23.76	1.00	30.00	PASS
		Middle	QPSK	1	0	23.56	0.26	23.82	1.00	30.00
	1			7	24.12	0.26	24.38	1.00	30.00	PASS
	1			14	24.02	0.26	24.28	1.00	30.00	PASS
	8			0	23.85	0.26	24.11	1.00	30.00	PASS
	8			4	23.69	0.26	23.95	1.00	30.00	PASS
	8			7	23.56	0.26	23.82	1.00	30.00	PASS
	15			0	23.55	0.26	23.81	1.00	30.00	PASS
	16QAM		1	0	23.97	0.26	24.23	1.00	30.00	PASS
			1	7	24.08	0.26	24.34	1.00	30.00	PASS
			1	14	23.89	0.26	24.15	1.00	30.00	PASS
			8	0	23.77	0.26	24.03	1.00	30.00	PASS
			8	4	23.51	0.26	23.77	1.00	30.00	PASS
			8	7	23.56	0.26	23.82	1.00	30.00	PASS
			15	0	23.54	0.26	23.80	1.00	30.00	PASS
			Highest	QPSK	1	0	23.80	0.26	24.06	1.00
	1	7			23.98	0.26	24.24	1.00	30.00	PASS
	1	14			23.89	0.26	24.15	1.00	30.00	PASS
	8	0			23.76	0.26	24.02	1.00	30.00	PASS
	8	4			23.65	0.26	23.91	1.00	30.00	PASS
	8	7			23.58	0.26	23.84	1.00	30.00	PASS
	15	0			23.38	0.26	23.64	1.00	30.00	PASS
	16QAM	1		0	23.97	0.26	24.23	1.00	30.00	PASS
1		7		23.97	0.26	24.23	1.00	30.00	PASS	
1		14		23.71	0.26	23.97	1.00	30.00	PASS	
8		0		23.72	0.26	23.98	1.00	30.00	PASS	
8		4		23.57	0.26	23.83	1.00	30.00	PASS	
8		7		23.49	0.26	23.75	1.00	30.00	PASS	
15		0		23.25	0.26	23.51	1.00	30.00	PASS	



Radiated Power (EIRP) for LTE Band 66 /5M										
BW (MHz)	UL Channel	RB Size	RB offset	Modulation	Conduction AVG Power(dBm)	Ant Gain (dBi)	EIRP (dBm)	EIRP Limit(W)	EIRP Limit(dBm)	Verdict
5	Lowest	1	0	QPSK	23.06	0.26	23.32	1.00	30.00	PASS
		1	12		23.50	0.26	23.76	1.00	30.00	PASS
		1	24		23.14	0.26	23.40	1.00	30.00	PASS
		12	0		22.17	0.26	22.43	1.00	30.00	PASS
		12	6		22.27	0.26	22.53	1.00	30.00	PASS
		12	11		22.30	0.26	22.56	1.00	30.00	PASS
		25	0		22.27	0.26	22.53	1.00	30.00	PASS
		1	0	16QAM	22.53	0.26	22.79	1.00	30.00	PASS
		1	12		22.96	0.26	23.22	1.00	30.00	PASS
		1	24		22.69	0.26	22.95	1.00	30.00	PASS
		12	0		21.20	0.26	21.46	1.00	30.00	PASS
		12	6		21.30	0.26	21.56	1.00	30.00	PASS
		12	11		21.28	0.26	21.54	1.00	30.00	PASS
		25	0		21.21	0.26	21.47	1.00	30.00	PASS
		Middle	QPSK	1	0	22.84	0.26	23.10	1.00	30.00
	1			12	23.39	0.26	23.65	1.00	30.00	PASS
	1			24	22.92	0.26	23.18	1.00	30.00	PASS
	12			0	21.86	0.26	22.12	1.00	30.00	PASS
	12			6	21.92	0.26	22.18	1.00	30.00	PASS
	12			11	21.83	0.26	22.09	1.00	30.00	PASS
	25			0	21.88	0.26	22.14	1.00	30.00	PASS
	16QAM		1	0	22.02	0.26	22.28	1.00	30.00	PASS
			1	12	22.53	0.26	22.79	1.00	30.00	PASS
			1	24	22.13	0.26	22.39	1.00	30.00	PASS
			12	0	20.81	0.26	21.07	1.00	30.00	PASS
			12	6	20.84	0.26	21.10	1.00	30.00	PASS
			12	11	20.82	0.26	21.08	1.00	30.00	PASS
			25	0	20.85	0.26	21.11	1.00	30.00	PASS
			Highest	QPSK	1	0	22.59	0.26	22.85	1.00
	1	12			23.14	0.26	23.40	1.00	30.00	PASS
	1	24			22.67	0.26	22.93	1.00	30.00	PASS
	12	0			21.64	0.26	21.90	1.00	30.00	PASS
	12	6			21.67	0.26	21.93	1.00	30.00	PASS
	12	11			21.56	0.26	21.82	1.00	30.00	PASS
	25	0			21.60	0.26	21.86	1.00	30.00	PASS
	16QAM	1		0	21.92	0.26	22.18	1.00	30.00	PASS
1		12		22.24	0.26	22.50	1.00	30.00	PASS	
1		24		21.96	0.26	22.22	1.00	30.00	PASS	
12		0		20.58	0.26	20.84	1.00	30.00	PASS	
12		6		20.62	0.26	20.88	1.00	30.00	PASS	
12		11		20.54	0.26	20.80	1.00	30.00	PASS	
25		0		20.53	0.26	20.79	1.00	30.00	PASS	





Radiated Power (EIRP) for LTE Band 66 /10M										
BW (MHz)	UL Channel	RB Size	RB offset	Modulation	Conduction AVG Power(dBm)	Ant Gain (dBi)	EIRP (dBm)	EIRP Limit(W)	EIRP Limit(dBm)	Verdict
10	Lowest	1	0	QPSK	23.16	0.26	23.42	1.00	30.00	PASS
		1	24		23.36	0.26	23.62	1.00	30.00	PASS
		1	49		23.21	0.26	23.47	1.00	30.00	PASS
		25	0		22.22	0.26	22.48	1.00	30.00	PASS
		25	12		22.30	0.26	22.56	1.00	30.00	PASS
		25	24		22.38	0.26	22.64	1.00	30.00	PASS
		50	0		22.37	0.26	22.63	1.00	30.00	PASS
		1	0	16QAM	22.31	0.26	22.57	1.00	30.00	PASS
		1	24		22.48	0.26	22.74	1.00	30.00	PASS
		1	49		22.30	0.26	22.56	1.00	30.00	PASS
		25	0		21.21	0.26	21.47	1.00	30.00	PASS
		25	12		21.28	0.26	21.54	1.00	30.00	PASS
		25	24		21.32	0.26	21.58	1.00	30.00	PASS
		50	0		21.36	0.26	21.62	1.00	30.00	PASS
	Middle	QPSK	1	0	23.01	0.26	23.27	1.00	30.00	PASS
			1	24	23.14	0.26	23.40	1.00	30.00	PASS
			1	49	23.07	0.26	23.33	1.00	30.00	PASS
			25	0	21.92	0.26	22.18	1.00	30.00	PASS
			25	12	21.93	0.26	22.19	1.00	30.00	PASS
			25	24	21.90	0.26	22.16	1.00	30.00	PASS
			50	0	21.90	0.26	22.16	1.00	30.00	PASS
		16QAM	1	0	21.61	0.26	21.87	1.00	30.00	PASS
			1	24	21.79	0.26	22.05	1.00	30.00	PASS
			1	49	21.78	0.26	22.04	1.00	30.00	PASS
			25	0	20.88	0.26	21.14	1.00	30.00	PASS
			25	12	20.87	0.26	21.13	1.00	30.00	PASS
			25	24	20.91	0.26	21.17	1.00	30.00	PASS
			50	0	20.87	0.26	21.13	1.00	30.00	PASS
	Highest	QPSK	1	0	22.69	0.26	22.95	1.00	30.00	PASS
			1	24	22.80	0.26	23.06	1.00	30.00	PASS
			1	49	22.73	0.26	22.99	1.00	30.00	PASS
			25	0	21.73	0.26	21.99	1.00	30.00	PASS
			25	12	21.64	0.26	21.90	1.00	30.00	PASS
			25	24	21.66	0.26	21.92	1.00	30.00	PASS
			50	0	21.70	0.26	21.96	1.00	30.00	PASS
		16QAM	1	0	22.01	0.26	22.27	1.00	30.00	PASS
1			24	22.03	0.26	22.29	1.00	30.00	PASS	
1			49	21.96	0.26	22.22	1.00	30.00	PASS	
25			0	20.71	0.26	20.97	1.00	30.00	PASS	
25			12	20.59	0.26	20.85	1.00	30.00	PASS	
25			24	20.60	0.26	20.86	1.00	30.00	PASS	
50			0	20.65	0.26	20.91	1.00	30.00	PASS	



Radiated Power (EIRP) for LTE Band 66 /15M										
BW (MHz)	UL Channel	RB Size	RB offset	Modulation	Conduction AVG Power(dBm)	Ant Gain (dBi)	EIRP (dBm)	EIRP Limit(W)	EIRP Limit(dBm)	Verdict
15	Lowest	1	0	QPSK	23.21	0.26	23.47	1.00	30.00	PASS
		1	37		23.64	0.26	23.90	1.00	30.00	PASS
		1	74		23.13	0.26	23.39	1.00	30.00	PASS
		36	0		22.26	0.26	22.52	1.00	30.00	PASS
		36	18		22.38	0.26	22.64	1.00	30.00	PASS
		36	39		22.36	0.26	22.62	1.00	30.00	PASS
		75	0		22.32	0.26	22.58	1.00	30.00	PASS
		1	0	16QAM	22.18	0.26	22.44	1.00	30.00	PASS
		1	37		22.63	0.26	22.89	1.00	30.00	PASS
		1	74		22.08	0.26	22.34	1.00	30.00	PASS
		36	0		21.23	0.26	21.49	1.00	30.00	PASS
		36	18		21.24	0.26	21.50	1.00	30.00	PASS
		36	39		21.28	0.26	21.54	1.00	30.00	PASS
		75	0		21.36	0.26	21.62	1.00	30.00	PASS
		1	0	QPSK	22.84	0.26	23.10	1.00	30.00	PASS
	1	37	23.23		0.26	23.49	1.00	30.00	PASS	
	1	74	22.96		0.26	23.22	1.00	30.00	PASS	
	36	0	22.04		0.26	22.30	1.00	30.00	PASS	
	36	18	22.06		0.26	22.32	1.00	30.00	PASS	
	36	39	22.06		0.26	22.32	1.00	30.00	PASS	
	75	0	22.08		0.26	22.34	1.00	30.00	PASS	
	1	0	16QAM	22.04	0.26	22.30	1.00	30.00	PASS	
	1	37		22.48	0.26	22.74	1.00	30.00	PASS	
	1	74		22.27	0.26	22.53	1.00	30.00	PASS	
	36	0		20.97	0.26	21.23	1.00	30.00	PASS	
	36	18		21.07	0.26	21.33	1.00	30.00	PASS	
	36	39		21.02	0.26	21.28	1.00	30.00	PASS	
	75	0		20.98	0.26	21.24	1.00	30.00	PASS	
	1	0	QPSK	22.75	0.26	23.01	1.00	30.00	PASS	
	1	37		22.99	0.26	23.25	1.00	30.00	PASS	
	1	74		22.71	0.26	22.97	1.00	30.00	PASS	
	36	0		21.80	0.26	22.06	1.00	30.00	PASS	
	36	18		21.82	0.26	22.08	1.00	30.00	PASS	
	36	39		21.81	0.26	22.07	1.00	30.00	PASS	
	75	0		21.84	0.26	22.10	1.00	30.00	PASS	
	1	0	16QAM	21.85	0.26	22.11	1.00	30.00	PASS	
1	37	22.01		0.26	22.27	1.00	30.00	PASS		
1	74	21.67		0.26	21.93	1.00	30.00	PASS		
36	0	20.81		0.26	21.07	1.00	30.00	PASS		
36	18	20.84		0.26	21.10	1.00	30.00	PASS		
36	39	20.78		0.26	21.04	1.00	30.00	PASS		
75	0	20.72		0.26	20.98	1.00	30.00	PASS		



Radiated Power (EIRP) for LTE Band 66 /20M										
BW (MHz)	UL Channel	RB Size	RB offset	Modulation	Conduction AVG Power(dBm)	Ant Gain (dBi)	EIRP (dBm)	EIRP Limit(W)	EIRP Limit(dBm)	Verdict
20	Lowest	1	0	QPSK	22.96	0.26	23.22	1.00	30.00	PASS
		1	49		24.32	0.26	24.58	1.00	30.00	PASS
		1	99		22.81	0.26	23.07	1.00	30.00	PASS
		50	0		22.18	0.26	22.44	1.00	30.00	PASS
		50	24		22.29	0.26	22.55	1.00	30.00	PASS
		50	49		22.28	0.26	22.54	1.00	30.00	PASS
		100	0		22.22	0.26	22.48	1.00	30.00	PASS
		1	0	16QAM	22.16	0.26	22.42	1.00	30.00	PASS
		1	49		22.52	0.26	22.78	1.00	30.00	PASS
		1	99		21.90	0.26	22.16	1.00	30.00	PASS
		50	0		21.22	0.26	21.48	1.00	30.00	PASS
		50	24		21.29	0.26	21.55	1.00	30.00	PASS
		50	49		21.32	0.26	21.58	1.00	30.00	PASS
		100	0		21.26	0.26	21.52	1.00	30.00	PASS
	Middle	QPSK	1	0	22.72	0.26	22.98	1.00	30.00	PASS
			1	49	23.21	0.26	23.47	1.00	30.00	PASS
			1	99	22.84	0.26	23.10	1.00	30.00	PASS
			50	0	21.98	0.26	22.24	1.00	30.00	PASS
			50	24	22.00	0.26	22.26	1.00	30.00	PASS
			50	49	21.99	0.26	22.25	1.00	30.00	PASS
			100	0	21.98	0.26	22.24	1.00	30.00	PASS
		16QAM	1	0	21.84	0.26	22.10	1.00	30.00	PASS
			1	49	22.32	0.26	22.58	1.00	30.00	PASS
			1	99	22.08	0.26	22.34	1.00	30.00	PASS
			50	0	20.97	0.26	21.23	1.00	30.00	PASS
			50	24	21.01	0.26	21.27	1.00	30.00	PASS
			50	49	21.00	0.26	21.26	1.00	30.00	PASS
			100	0	20.99	0.26	21.25	1.00	30.00	PASS
	Highest	QPSK	1	0	22.78	0.26	23.04	1.00	30.00	PASS
			1	49	22.97	0.26	23.23	1.00	30.00	PASS
			1	99	22.67	0.26	22.93	1.00	30.00	PASS
			50	0	21.82	0.26	22.08	1.00	30.00	PASS
			50	24	21.78	0.26	22.04	1.00	30.00	PASS
			50	49	21.62	0.26	21.88	1.00	30.00	PASS
			100	0	21.74	0.26	22.00	1.00	30.00	PASS
		16QAM	1	0	21.97	0.26	22.23	1.00	30.00	PASS
			1	49	22.04	0.26	22.30	1.00	30.00	PASS
			1	99	21.59	0.26	21.85	1.00	30.00	PASS
			50	0	20.79	0.26	21.05	1.00	30.00	PASS
			50	24	20.71	0.26	20.97	1.00	30.00	PASS
			50	49	20.59	0.26	20.85	1.00	30.00	PASS
			100	0	20.71	0.26	20.97	1.00	30.00	PASS

## 5.2 PEAK TO AVERAGE RATIO

### TEST OVERVIEW

According to §24.232(d), power measurements for transmissions by stations authorized under this section may be made either in accordance with a commission-approved average power technique or in compliance with paragraph (e) of this section. In both instances, equipment employed must be authorized in accordance with the provisions of §24.51. In measuring transmissions in this band using an average power technique, the peak-to-average ratio (PAR) of the transmission may not exceed 13 db.

### TEST PROCEDURES

1. The testing follows FCC KDB 971168 v03r01 section.
2. The eut was connected to the peak and av system simulator& spectrum analyzer.
3. Select lowest, middle, and highest channels for each band and different modulation.
4. Set the test probe and measure average power of the spectrum analysis,

### TEST SETUP

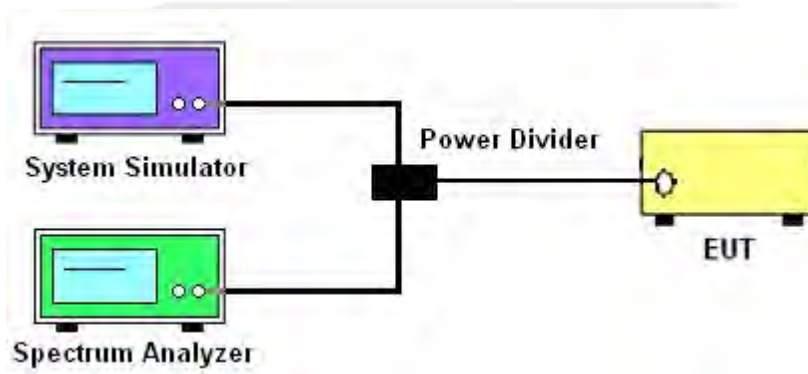

### TEST RESULT

Note: The test data please reference to attachment “STS2302331W01\_Appendix GSM” , “STS2302331W01\_Appendix WCDMA” and “STS2302331W01\_Appendix LTE”.

## 5.3 OCCUPIED BANDWIDTH

### TEST OVERVIEW

The occupied bandwidth, that is the frequency bandwidth such that, below its lower and above its upper frequency limits, the mean powers radiated are each equal to 0.5 percent of the total mean power radiated by a given emission shall be measured.

The 26 dB emission bandwidth is defined as the frequency range between two points, one above and one below the carrier frequency, at which the spectral density of the emission is attenuated 26 dB below the maximum in-band spectral density of the modulated signal. Spectral density (power per unit bandwidth) is to be measured with a detector of resolution bandwidth equal to approximately 1.0% of the emission bandwidth.

All modes of operation were investigated and the worst case configuration results are reported in this section.

### TEST PROCEDURE

1. The signal analyzer's automatic bandwidth measurement capability was used to perform the 99% occupied bandwidth and the 26dB bandwidth. The bandwidth measurement was not influenced by any intermediate power nulls in the fundamental emission.
2. RBW = 1 – 5% of the expected OBW
3. VBW  $\geq$  3 x RBW
4. Detector = Peak
5. Trace mode = max hold
6. Sweep = auto couple
7. The trace was allowed to stabilize
8. If necessary, steps 2 – 7 were repeated after changing the RBW such that it would be within 1 – 5% of the 99% occupied bandwidth observed in Step 7

### TEST SETUP

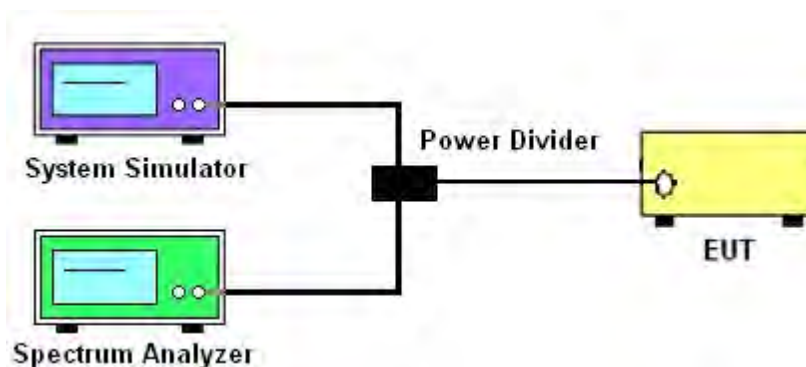

### TEST RESULT

Note: The test data please reference to attachment “STS2302331W01\_Appendix GSM” , “STS2302331W01\_Appendix WCDMA” and “STS2302331W01\_Appendix LTE”.



## 5.4 FREQUENCY STABILITY

### TEST OVERVIEW

Frequency stability testing is performed in accordance with the guidelines of ANSI C63.26 2015.

The frequency stability of the transmitter is measured by:

- a.) Temperature: The temperature is varied from  $-30^{\circ}\text{C}$  to  $+50^{\circ}\text{C}$  in  $10^{\circ}\text{C}$  increments using an environmental chamber.
- b.) Primary Supply Voltage: The primary supply voltage is varied from 85% to 115% of the nominal value for non hand-carried battery and AC powered equipment. For hand-carried, battery-powered equipment, primary supply voltage is reduced to the battery operating end point which shall be specified by the manufacturer.

For Part 22, the frequency stability of the transmitter shall be maintained within  $\pm 0.00025\%$  ( $\pm 2.5$  ppm) of the center frequency. For Part 24 the frequency stability shall be sufficient to ensure that the fundamental emission stays within the authorized frequency block.

### TEST PROCEDURE

#### Temperature Variation

1. The testing follows FCC KDB 971168 D01 section 9.0
2. The EUT was set up in the thermal chamber and connected with the system simulator.
3. With power OFF, the temperature was decreased to  $-30^{\circ}\text{C}$  and the EUT was stabilized before testing. Power was applied and the maximum change in frequency was recorded within one minute.
4. With power OFF, the temperature was raised in  $10^{\circ}\text{C}$  steps up to  $50^{\circ}\text{C}$ . The EUT was stabilized at each step for at least half an hour. Power was applied and the maximum frequency change was recorded within one minute.

#### Voltage Variation

1. The testing follows FCC KDB 971168 D01 Section 9.0.
2. The EUT was placed in a temperature chamber at  $25\pm 5^{\circ}\text{C}$  and connected with the system simulator.
3. The power supply voltage to the EUT was varied from 85% to 115% of the nominal value measured at the input to the EUT.
4. The variation in frequency was measured for the worst case.

### TEST SETUP

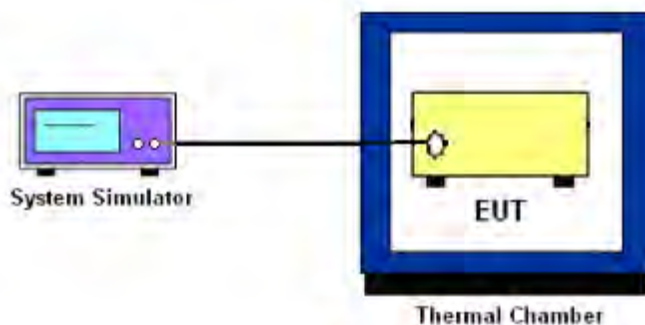



TEST RESULT

GPRS 850 /836.6MHz					
Temperature (°C)	Voltage	Freq. Dev.	Freq. Dev.	Limit	Result
	(Volt)	(Hz)	(ppm)		
50	Normal Voltage	27.85	0.033	2.5ppm	PASS
40		19.18	0.023		
30		20.40	0.024		
20		24.17	0.029		
10		21.17	0.025		
0		27.35	0.033		
-10		29.58	0.035		
-20		23.35	0.028		
-30		16.98	0.020		
20		Maximum Voltage	15.72		
20	BEP	34.46	0.041		

EGPRS 850 /836.6MHz					
Temperature (°C)	Voltage	Freq. Dev.	Freq. Dev.	Limit	Result
	(Volt)	(Hz)	(ppm)		
50	Normal Voltage	25.38	0.030	2.5ppm	PASS
40		13.45	0.016		
30		22.62	0.027		
20		21.93	0.026		
10		32.23	0.039		
0		20.76	0.025		
-10		28.02	0.033		
-20		18.92	0.023		
-30		12.27	0.015		
20		Maximum Voltage	30.97		
20	BEP	26.64	0.032		



GPRS 1900 / 1880MHz					
Temperature (°C)	Voltage	Freq. Dev.	Freq. Dev.	Limit	Result
	(Volt)	(Hz)	(ppm)		
50	Normal Voltage	34.29	0.018	Within Authorized Band	PASS
40		34.24	0.018		
30		32.32	0.017		
20		22.07	0.012		
10		24.19	0.013		
0		14.88	0.008		
-10		35.62	0.019		
-20		12.67	0.007		
-30		16.21	0.009		
20		Maximum Voltage	15.91		
20	BEP	29.38	0.016		

EGPRS 1900 / 1880MHz					
Temperature (°C)	Voltage	Freq. Dev.	Freq. Dev.	Limit	Result
	(Volt)	(Hz)	(ppm)		
50	Normal Voltage	30.04	0.016	Within Authorized Band	PASS
40		21.12	0.011		
30		15.98	0.009		
20		27.94	0.015		
10		15.99	0.009		
0		26.45	0.014		
-10		27.66	0.015		
-20		28.39	0.015		
-30		29.84	0.016		
20		Maximum Voltage	33.28		
20	BEP	31.91	0.017		



UMTS Band 2 /1880MHz					
Temperature (°C)	Voltage	Freq. Dev.	Freq. Dev.	Limit	Result
	(Volt)	(Hz)	(ppm)		
50	Normal Voltage	32.06	0.017	Within Authorized Band	PASS
40		16.12	0.009		
30		29.70	0.016		
20		16.65	0.009		
10		33.01	0.018		
0		14.76	0.008		
-10		14.18	0.008		
-20		13.29	0.007		
-30		30.04	0.016		
20		Maximum Voltage	12.11		
20	BEP	15.69	0.008		

HSDPA Band 2 /1880MHz					
Temperature (°C)	Voltage	Freq. Dev.	Freq. Dev.	Limit	Result
	(Volt)	(Hz)	(ppm)		
50	Normal Voltage	18.40	0.010	Within Authorized Band	PASS
40		14.09	0.007		
30		22.54	0.012		
20		25.15	0.013		
10		26.15	0.014		
0		27.22	0.014		
-10		35.44	0.019		
-20		31.88	0.017		
-30		26.80	0.014		
20		Maximum Voltage	15.74		
20	BEP	34.35	0.018		

HSUPA Band 2 /1880MHz					
Temperature (°C)	Voltage	Freq. Dev.	Freq. Dev.	Limit	Result
	(Volt)	(Hz)	(ppm)		
50	Normal Voltage	20.35	0.011	Within Authorized Band	PASS
40		19.22	0.010		
30		16.10	0.009		
20		16.04	0.009		
10		31.95	0.017		
0		23.71	0.013		
-10		35.07	0.019		
-20		26.19	0.014		
-30		25.52	0.014		
20		Maximum Voltage	22.33		
20	BEP	17.46	0.009		



UMTS Band 5 / 836.4MHz					
Temperature (°C)	Voltage	Freq. Dev.	Freq. Dev.	Limit	Result
	(Volt)	(Hz)	(ppm)		
50	Normal Voltage	34.37	0.041	2.5ppm	PASS
40		15.89	0.019		
30		21.63	0.026		
20		23.24	0.028		
10		14.42	0.017		
0		25.48	0.030		
-10		20.16	0.024		
-20		14.37	0.017		
-30		16.00	0.019		
20		Maximum Voltage	29.63		
20	BEP	12.61	0.015		

HSDPA Band 5 / 836.4MHz					
Temperature (°C)	Voltage	Freq. Dev.	Freq. Dev.	Limit	Result
	(Volt)	(Hz)	(ppm)		
50	Normal Voltage	35.38	0.042	2.5ppm	PASS
40		18.05	0.022		
30		14.68	0.018		
20		24.15	0.029		
10		22.14	0.026		
0		24.50	0.029		
-10		36.07	0.043		
-20		35.36	0.042		
-30		28.42	0.034		
20		Maximum Voltage	27.69		
20	BEP	12.65	0.015		

HSUPA Band 5 / 836.4MHz					
Temperature (°C)	Voltage	Freq. Dev.	Freq. Dev.	Limit	Result
	(Volt)	(Hz)	(ppm)		
50	Normal Voltage	19.15	0.023	2.5ppm	PASS
40		30.09	0.036		
30		27.11	0.032		
20		25.87	0.031		
10		30.27	0.036		
0		20.23	0.024		
-10		15.28	0.018		
-20		21.77	0.026		
-30		12.12	0.014		
20		Maximum Voltage	35.72		
20	BEP	33.25	0.040		





UMTS Band 4 /1740MHz					
Temperature (°C)	Voltage	Freq. Dev.	Freq. Dev.	Limit	Result
	(Volt)	(Hz)	(ppm)		
50	Normal Voltage	14.22	0.008	Within Authorized Band	PASS
40		18.37	0.010		
30		23.52	0.013		
20		34.73	0.018		
10		31.74	0.017		
0		26.41	0.014		
-10		11.60	0.006		
-20		22.51	0.012		
-30		35.60	0.019		
20		Maximum Voltage	13.37		
20	BEP	31.49	0.017		

HSDPA Band 4 /1740MHz						
Temperature (°C)	Voltage	Freq. Dev.	Freq. Dev.	Limit	Result	
	(Volt)	(Hz)	(ppm)			
50	Normal Voltage	14.36	0.008	Within Authorized Band	PASS	
40		19.65	0.010			
30		29.56	0.016			
20		31.72	0.017			
10		26.60	0.014			
0		26.71	0.014			
-10		31.43	0.017			
-20		14.17	0.008			
-30		14.54	0.008			
20		Maximum Voltage	17.68			0.009
20		BEP	31.35			0.017

HSUPA Band 4 /1740MHz					
Temperature (°C)	Voltage	Freq. Dev.	Freq. Dev.	Limit	Result
	(Volt)	(Hz)	(ppm)		
50	Normal Voltage	23.08	0.012	Within Authorized Band	PASS
40		35.69	0.019		
30		12.38	0.007		
20		32.05	0.017		
10		20.70	0.011		
0		36.27	0.019		
-10		13.44	0.007		
-20		31.52	0.017		
-30		17.24	0.009		
20		Maximum Voltage	27.18		
20	BEP	14.43	0.008		



LTE Band 2 (QPSK) / 1880MHz / BW10M					
Temperature (°C)	Voltage	Freq. Dev.	Freq. Dev.	Limit	Result
	(Volt)	(Hz)	(ppm)		
50	Normal Voltage	26.15	0.014	2.5ppm	PASS
40		12.80	0.007		
30		23.54	0.013		
20		34.82	0.019		
10		23.93	0.013		
0		17.71	0.009		
-10		15.34	0.008		
-20		29.13	0.015		
-30		36.05	0.019		
20		Maximum Voltage	28.62		
20	BEP	35.71	0.019		

LTE Band 2 (QPSK) / 1880MHz / BW20M					
Temperature (°C)	Voltage	Freq. Dev.	Freq. Dev.	Limit	Result
	(Volt)	(Hz)	(ppm)		
50	Normal Voltage	32.08	0.017	2.5ppm	PASS
40		25.31	0.013		
30		26.18	0.014		
20		11.56	0.006		
10		21.94	0.012		
0		30.34	0.016		
-10		12.07	0.006		
-20		18.36	0.010		
-30		23.39	0.012		
20		Maximum Voltage	15.62		
20	BEP	19.09	0.010		



LTE Band 4 (QPSK) / 1733MHz / BW10M					
Temperature (°C)	Voltage	Freq. Dev.	Freq. Dev.	Limit	Result
	(Volt)	(Hz)	(ppm)		
50	Normal Voltage	34.63	0.020	2.5ppm	PASS
40		30.50	0.018		
30		12.64	0.007		
20		17.43	0.010		
10		15.44	0.009		
0		28.17	0.016		
-10		13.50	0.008		
-20		22.23	0.013		
-30		16.53	0.010		
20		Maximum Voltage	28.94		
20	BEP	36.44	0.021		

LTE Band 4 (QPSK) / 1733MHz / BW20M					
Temperature (°C)	Voltage	Freq. Dev.	Freq. Dev.	Limit	Result
	(Volt)	(Hz)	(ppm)		
50	Normal Voltage	18.63	0.011	2.5ppm	PASS
40		27.20	0.016		
30		25.27	0.015		
20		32.99	0.019		
10		31.35	0.018		
0		25.13	0.015		
-10		23.10	0.013		
-20		32.89	0.019		
-30		34.92	0.020		
20		Maximum Voltage	30.11		
20	BEP	12.62	0.007		



LTE Band 5 (QPSK) / 836.5MHz / BW5M					
Temperature (°C)	Voltage	Freq. Dev.	Freq. Dev.	Limit	Result
	(Volt)	(Hz)	(ppm)		
50	Normal Voltage	27.80	0.039	2.5ppm	PASS
40		12.45	0.018		
30		31.95	0.045		
20		29.87	0.042		
10		27.51	0.039		
0		25.41	0.036		
-10		22.87	0.003		
-20		13.35	0.019		
-30		27.40	0.039		
20		Maximum Voltage	29.42		
20	BEP	25.74	0.036		

LTE Band 5 (QPSK) / 836.5MHz / BW10M					
Temperature (°C)	Voltage	Freq. Dev.	Freq. Dev.	Limit	Result
	(Volt)	(Hz)	(ppm)		
50	Normal Voltage	12.91	0.018	2.5ppm	PASS
40		30.78	0.043		
30		34.18	0.048		
20		21.83	0.031		
10		35.29	0.050		
0		20.40	0.029		
-10		35.73	0.005		
-20		30.78	0.043		
-30		33.00	0.046		
20		Maximum Voltage	31.50		
20	BEP	35.32	0.050		



LTE Band 7 (QPSK) / 2535MHz / BW10M					
Temperature (°C)	Voltage	Freq. Dev.	Freq. Dev.	Limit	Result
	(Volt)	(Hz)	(ppm)		
50	Normal Voltage	22.94	0.009	2.5ppm	PASS
40		15.70	0.006		
30		13.75	0.005		
20		23.81	0.009		
10		21.67	0.009		
0		34.63	0.014		
-10		14.47	0.006		
-20		32.36	0.013		
-30		28.93	0.011		
20		Maximum Voltage	14.00		
20	BEP	29.29	0.012		

LTE Band 7 (QPSK) / 2535MHz / BW20M					
Temperature (°C)	Voltage	Freq. Dev.	Freq. Dev.	Limit	Result
	(Volt)	(Hz)	(ppm)		
50	Normal Voltage	12.50	0.005	2.5ppm	PASS
40		28.67	0.011		
30		23.65	0.009		
20		32.24	0.013		
10		27.32	0.011		
0		24.95	0.010		
-10		36.40	0.014		
-20		23.67	0.009		
-30		17.33	0.007		
20		Maximum Voltage	23.15		
20	BEP	11.62	0.005		





LTE Band 12 (QPSK) / 707.5MHz / BW5M					
Temperature (°C)	Voltage	Freq. Dev.	Freq. Dev.	Limit	Result
	(Volt)	(Hz)	(ppm)		
50	Normal Voltage	20.78	0.029	2.5ppm	PASS
40		36.31	0.051		
30		32.80	0.046		
20		12.78	0.018		
10		28.66	0.040		
0		24.41	0.034		
-10		26.16	0.004		
-20		27.80	0.039		
-30		30.91	0.044		
20		Maximum Voltage	17.98		
20	BEP	16.90	0.024		

LTE Band 12 (QPSK) / 707.5MHz / BW10M					
Temperature (°C)	Voltage	Freq. Dev.	Freq. Dev.	Limit	Result
	(Volt)	(Hz)	(ppm)		
50	Normal Voltage	35.68	0.050	2.5ppm	PASS
40		29.91	0.042		
30		29.28	0.041		
20		18.18	0.026		
10		20.35	0.029		
0		14.12	0.020		
-10		17.40	0.002		
-20		17.92	0.025		
-30		13.15	0.019		
20		Maximum Voltage	11.55		
20	BEP	33.91	0.048		



LTE Band 13 (QPSK) / 782MHz / BW5M					
Temperature (°C)	Voltage	Freq. Dev.	Freq. Dev.	Limit	Result
	(Volt)	(Hz)	(ppm)		
50	Normal Voltage	23.05	0.032	2.5ppm	PASS
40		12.18	0.017		
30		13.41	0.019		
20		28.59	0.040		
10		33.68	0.047		
0		31.77	0.045		
-10		17.28	0.002		
-20		22.45	0.032		
-30		36.37	0.051		
20		Maximum Voltage	26.28		
20	BEP	30.30	0.043		

LTE Band 13 (QPSK) / 782MHz / BW10M					
Temperature (°C)	Voltage	Freq. Dev.	Freq. Dev.	Limit	Result
	(Volt)	(Hz)	(ppm)		
50	Normal Voltage	15.15	0.021	2.5ppm	PASS
40		12.73	0.018		
30		11.59	0.016		
20		19.34	0.027		
10		21.12	0.030		
0		33.98	0.048		
-10		35.22	0.005		
-20		26.26	0.037		
-30		25.83	0.036		
20		Maximum Voltage	13.13		
20	BEP	20.54	0.029		



LTE Band 17 (QPSK) / 710MHz / BW5M					
Temperature (°C)	Voltage	Freq. Dev.	Freq. Dev.	Limit	Result
	(Volt)	(Hz)	(ppm)		
50	Normal Voltage	23.05	0.032	2.5ppm	PASS
40		21.23	0.030		
30		23.41	0.033		
20		32.08	0.045		
10		18.85	0.027		
0		27.50	0.039		
-10		19.57	0.003		
-20		30.11	0.042		
-30		31.61	0.045		
20		Maximum Voltage	20.74		
20	BEP	15.16	0.021		

LTE Band 17 (QPSK) / 710MHz / BW10M					
Temperature (°C)	Voltage	Freq. Dev.	Freq. Dev.	Limit	Result
	(Volt)	(Hz)	(ppm)		
50	Normal Voltage	26.55	0.037	2.5ppm	PASS
40		16.70	0.024		
30		35.08	0.049		
20		36.34	0.051		
10		33.18	0.047		
0		25.27	0.036		
-10		28.90	0.004		
-20		18.90	0.027		
-30		21.77	0.031		
20		Maximum Voltage	20.97		
20	BEP	30.94	0.044		



LTE Band 26(Part 22) (QPSK) / 836.5MHz / BW10M					
Temperature (°C)	Voltage	Freq. Dev.	Freq. Dev.	Limit	Result
	(Volt)	(Hz)	(ppm)		
50	Normal Voltage	29.28	0.017	2.5ppm	PASS
40		14.07	0.008		
30		23.52	0.014		
20		33.29	0.019		
10		20.03	0.012		
0		30.47	0.018		
-10		15.94	0.009		
-20		34.83	0.020		
-30		23.74	0.014		
20		Maximum Voltage	35.40		
20	BEP	20.66	0.012		

LTE Band 26(Part 22) (QPSK) / 836.5MHz / BW20M					
Temperature (°C)	Voltage	Freq. Dev.	Freq. Dev.	Limit	Result
	(Volt)	(Hz)	(ppm)		
50	Normal Voltage	20.82	0.012	2.5ppm	PASS
40		18.35	0.011		
30		36.10	0.021		
20		29.01	0.017		
10		18.13	0.010		
0		22.02	0.013		
-10		30.19	0.017		
-20		36.03	0.021		
-30		24.75	0.014		
20		Maximum Voltage	25.52		
20	BEP	22.23	0.013		



LTE Band 26(Part 90) (QPSK) / 819MHz / BW5M					
Temperature (°C)	Voltage	Freq. Dev.	Freq. Dev.	Limit	Result
	(Volt)	(Hz)	(ppm)		
50	Normal Voltage	25.24	0.015	2.5ppm	PASS
40		23.82	0.014		
30		27.03	0.016		
20		20.86	0.012		
10		19.38	0.011		
0		15.07	0.009		
-10		29.09	0.017		
-20		29.84	0.017		
-30		32.48	0.019		
20		Maximum Voltage	18.80		
20	BEP	29.90	0.017		

LTE Band 26(Part 90) (QPSK) / 819MHz / BW10M					
Temperature (°C)	Voltage	Freq. Dev.	Freq. Dev.	Limit	Result
	(Volt)	(Hz)	(ppm)		
50	Normal Voltage	22.00	0.013	2.5ppm	PASS
40		16.22	0.009		
30		11.93	0.007		
20		32.37	0.019		
10		11.93	0.007		
0		24.83	0.014		
-10		19.99	0.012		
-20		23.97	0.014		
-30		32.52	0.019		
20		Maximum Voltage	36.17		
20	BEP	14.03	0.008		





LTE Band 41 (QPSK) / 2605MHz / BW10M					
Temperature (°C)	Voltage	Freq. Dev.	Freq. Dev.	Limit	Result
	(Volt)	(Hz)	(ppm)		
50	Normal Voltage	33.37	0.013	2.5ppm	PASS
40		21.52	0.008		
30		18.64	0.007		
20		20.69	0.008		
10		18.72	0.007		
0		12.15	0.005		
-10		35.30	0.014		
-20		25.36	0.010		
-30		11.53	0.005		
20		Maximum Voltage	20.25		
20	BEP	25.89	0.010		

LTE Band 41 (QPSK) / 2605MHz / BW20M					
Temperature (°C)	Voltage	Freq. Dev.	Freq. Dev.	Limit	Result
	(Volt)	(Hz)	(ppm)		
50	Normal Voltage	16.57	0.007	2.5ppm	PASS
40		14.45	0.006		
30		13.85	0.005		
20		31.13	0.012		
10		14.55	0.006		
0		17.35	0.007		
-10		14.56	0.006		
-20		27.31	0.011		
-30		25.12	0.010		
20		Maximum Voltage	25.83		
20	BEP	21.85	0.009		



LTE Band 66 (QPSK) / 1745MHz / BW10M					
Temperature (°C)	Voltage	Freq. Dev.	Freq. Dev.	Limit	Result
	(Volt)	(Hz)	(ppm)		
50	Normal Voltage	25.36	0.015	2.5ppm	PASS
40		35.78	0.021		
30		24.97	0.014		
20		24.84	0.014		
10		20.83	0.012		
0		13.26	0.008		
-10		12.29	0.007		
-20		24.22	0.014		
-30		18.58	0.011		
20		Maximum Voltage	33.57		
20	BEP	28.00	0.016		

LTE Band 66 (QPSK) / 1745MHz / BW20M					
Temperature (°C)	Voltage	Freq. Dev.	Freq. Dev.	Limit	Result
	(Volt)	(Hz)	(ppm)		
50	Normal Voltage	21.15	0.012	2.5ppm	PASS
40		33.24	0.019		
30		33.06	0.019		
20		15.02	0.009		
10		20.07	0.012		
0		15.91	0.009		
-10		36.25	0.021		
-20		23.87	0.014		
-30		20.33	0.012		
20		Maximum Voltage	30.85		
20	BEP	22.57	0.013		

## 5.5 SPURIOUS EMISSIONS AT ANTENNA TERMINALS

### TEST OVERVIEW

The power of any emission outside of the authorized operating frequency ranges must be lower than the transmitter power (P) by a factor of at least  $43 + 10 \log (P)$  dB.

For Band 7:

The power of any emission outside of the authorized operating frequency ranges must be lower than the transmitter power (P) by a factor of at least  $55 + 10 \log (P)$  dB.

It is measured by means of a calibrated spectrum analyzer and scanned from 30 MHz up to a frequency including its 10th harmonic.

### TEST PROCEDURE

1. The testing FCC KDB 971168 D01 v03r01 Section 6.0. and ANSI C63.26-2015-Section 5.7.
2. The EUT was connected to the spectrum analyzer and system simulator via a power divider.
3. The RF output of EUT was connected to the spectrum analyzer by an RF cable and attenuator. The path loss was compensated to the results for each measurement.
4. The middle channel for the highest RF power within the transmitting frequency was measured.
5. The conducted spurious emission for the whole frequency range was taken.
6. The RF fundamental frequency should be excluded against the limit line in the operating frequency band.
7. The limit line is derived from  $43 + 10\log(P)$  dB below the transmitter power P(Watts)  
 $= P(W) - [43 + 10\log(P)]$  (dB)  
 $= [30 + 10\log(P)]$  (dBm) -  $[43 + 10\log(P)]$  (dB)  
 $= -13\text{dBm}$ .

### TEST SETUP

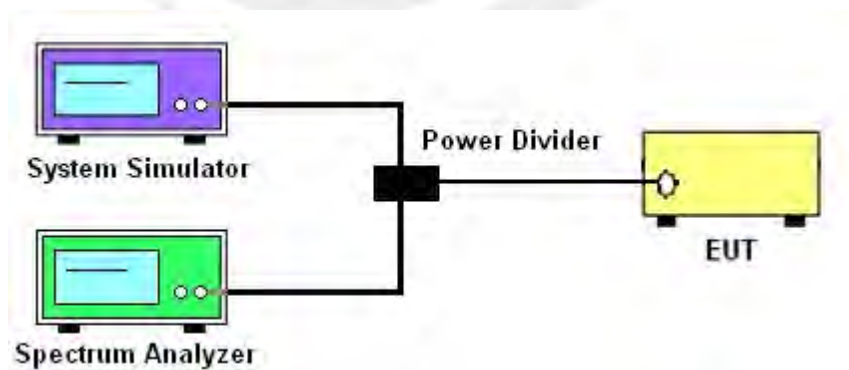

### TEST RESULT

Note: The test data please reference to attachment “STS2302331W01\_Appendix GSM”, “STS2302331W01\_Appendix WCDMA” and “STS2302331W01\_Appendix LTE”.



## 5.6 BAND EDGE

### TEST OVERVIEW

#### 1. §22.917(a)

For operations in the 824 – 849 MHz band, the FCC limit is  $43 + 10\log_{10}(P[\text{Watts}])$  dB below the transmitter power  $P(\text{Watts})$  in a 100kHz bandwidth. However, in the 1MHz bands immediately outside and adjacent to the licensee's frequency block, a resolution bandwidth of at least one percent of the emission bandwidth of the fundamental emission of the transmitter may be employed.

#### 2. §24.238 (a)

For operations in the 1850-1910 and 1930-1990 MHz band, the FCC limit is  $43 + 10\log_{10}(P[\text{Watts}])$  dB below the transmitter power  $P(\text{Watts})$  in a 1MHz bandwidth. However, in the 1 MHz bands immediately outside and adjacent to the frequency block a resolution bandwidth of at least one percent of the emission bandwidth of the fundamental emission of the transmitter may be employed

#### 3. §27.53 (h)

For operations in the 1710 – 1755 MHz band, the FCC limit is  $43 + 10\log_{10}(P[\text{Watts}])$  dB below the transmitter power  $P(\text{Watts})$  in a 1 MHz bandwidth. However, in the 1MHz bands immediately outside and adjacent to the licensee's frequency block, a resolution bandwidth of at least one percent of the emission bandwidth of the fundamental emission of the transmitter may be employed.

#### 4. §27.53(m)(4)

For operations in the 2500 MHz ~ 2570 MHz band this section, the attenuation factor shall be not less than  $40 + 10 \log (P)$  dB on all frequencies between the channel edge and 5 megahertz from the channel edge,  $43 + 10 \log (P)$  dB on all frequencies between 5 megahertz and X megahertz from the channel edge, and  $55 + 10 \log (P)$  dB on all frequencies more than X megahertz from the channel edge, where X is the greater of 6 megahertz or the actual emission bandwidth as defined in paragraph (m)(6) of this section. In addition, the attenuation factor shall not be less that  $43 + 10 \log (P)$  dB on all frequencies between 2490.5 MHz and 2496 MHz and  $55 + 10 \log (P)$  dB at or below 2490.5 MHz. Mobile Satellite Service licensees operating on frequencies below 2495 MHz may also submit a documented interference complaint against BRS licensees operating on channel BRS Channel 1 on the same terms and conditions as adjacent channel BRS or EBS licensees.

#### 5. §27.53 (g)

For operations in the 698 -746 MHz band, the FCC limit is  $43 + 10\log_{10}(P[\text{Watts}])$  dB below the transmitter power  $P(\text{Watts})$  in a 100 kHz bandwidth. However, in the 100 kilohertz bands immediately outside and adjacent to a licensee's frequency block, a resolution bandwidth of at least 30 kHz may be employed.

## TEST PROCEDURE

1. The testing FCC KDB 971168 D01 v03r01 Section 6.0 and ANSI C63.26-2015-Section 5.7
2. Start and stop frequency were set such that the band edge would be placed in the center of the Plot.
3. The EUT was connected to the spectrum analyzer and system simulator via a power divider.
4. The RF output of EUT was connected to the spectrum analyzer by an RF cable and attenuator. The path loss was compensated to the results for each measurement.
5. The band edges of low and high channels for the highest RF powers were measured.
6. The RF fundamental frequency should be excluded against the limit line in the operating frequency band.

7. The limit line is derived from  $43 + 10\log(P)$  dB below the transmitter power P(Watts)

$$= P(W) - [43 + 10\log(P)] \text{ (dB)}$$

$$= [30 + 10\log(P)] \text{ (dBm)} - [43 + 10\log(P)] \text{ (dB)}$$

$$= -13\text{dBm.}$$

Band 7:

$$= P(W) - [55 + 10\log(P)] \text{ (dB)}$$

$$= [30 + 10\log(P)] \text{ (dBm)} - [55 + 10\log(P)] \text{ (dB)}$$

$$= -25\text{dBm.}$$

## TEST SETUP

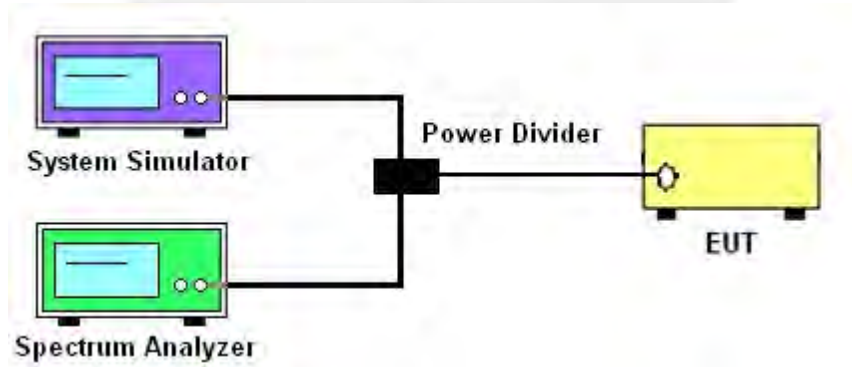

## TEST RESULT

Note: The test data please reference to attachment “STS2302331W01\_Appendix GSM”, “STS2302331W01\_Appendix WCDMA” and “STS2302331W01\_Appendix LTE”.



## 5.7 FIELD STRENGTH OF SPURIOUS RADIATION MEASUREMENT

### TEST OVERVIEW

Radiated spurious emissions measurements are performed using the substitution method described in ANSI C63.26-2015 with the EUT transmitting into an integral antenna. Measurements on signals operating below 1GHz are performed using horizontally and vertically polarized tuned dipole antennas. Measurements on signals operating above 1GHz are performed using vertically and horizontally polarized horn antennas. All measurements are performed as peak measurements while the EUT is operating at maximum power and at the appropriate frequencies.

It is measured by means of a calibrated spectrum analyzer and scanned from 30 MHz up to a frequency including its 10th harmonic.

### TEST PROCEDURE

1. The testing FCC KDB 971168 D01 Section 5.8 and ANSI C63.26-2015-Section 5.5.
2. RBW = 100kHz for emissions below 1GHz and 1MHz for emissions above 1GHz
3. VBW  $\geq 3 \times$  RBW
4. Span = 1.5 times the OBW
5. No. of sweep points  $> 2 \times$  span/RBW
6. Detector = Peak
7. Trace mode = max hold
8. The trace was allowed to stabilize
9. Effective Isotropic Spurious Radiation was measured by substitution method according to TIA/EIA-603-D. The EUT was replaced by the substitution antenna at same location, and then a known power from S.G. was applied into the dipole antenna through a Tx cable, and then recorded the maximum Analyzer reading through raised and lowered the test antenna.  
 $P_{Mea} = S.G \text{ Level} + \text{Ant-Cable loss}$ ;  $\text{Margin} = P_{Mea} - \text{Limit}$ .



### TEST SETUP

For radiated test from 30MHz to 1GHz

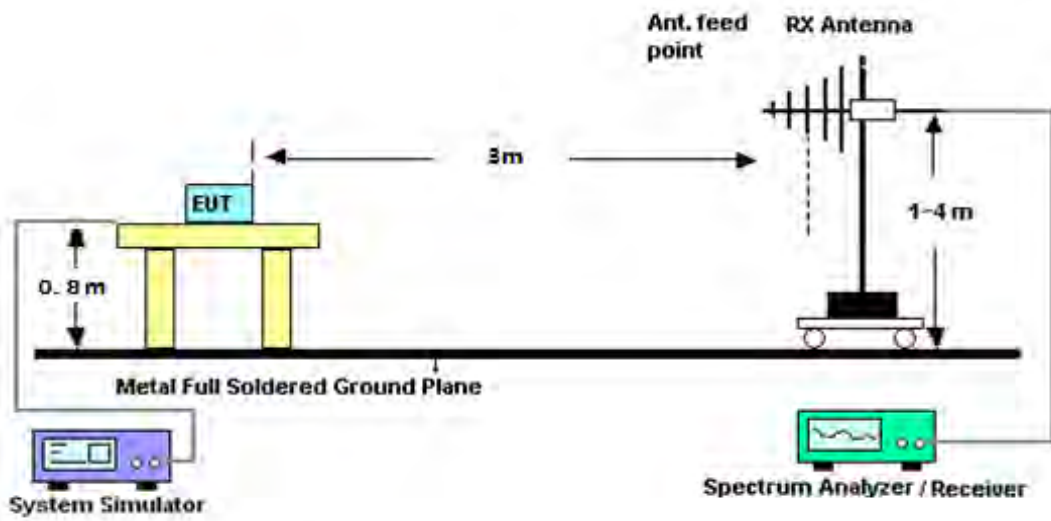

For radiated test from above 1GHz

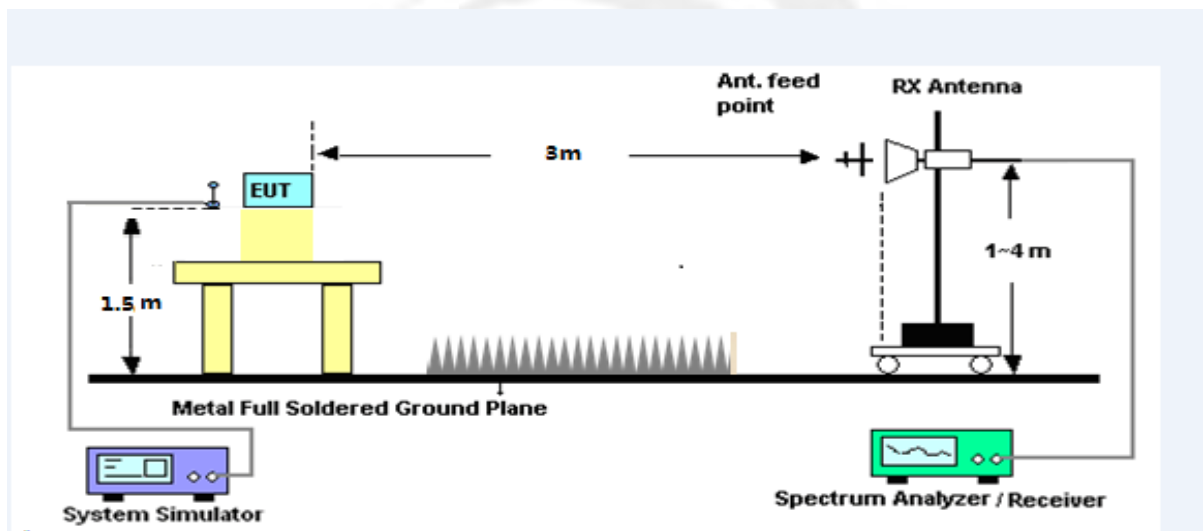



**TEST RESULT**

**Note:** (1) Spurious emissions which are attenuated by more than 20dB below the permissible value for frequency below 1000MHz.

(2) Above 3.5GHz amplitude of spurious emissions which are attenuated by more than 20dB below the permissible value

(3) Test is divided into three directions, X/Y/Z. X pattern for the worst.

GPRS 850: (30-9000)MHz							
The Worst Test Results Channel 128/824.2 MHz							
Frequency(MHz)	S	Ant(dBi)	Loss	PMea	Limit	Margin	Polarity
	G.Lev (dBm)			(dBm)	(dBm)	(dBm)	
1648.12	-41.03	9.40	4.75	-36.38	-13.00	-23.38	H
2472.41	-40.44	10.60	8.39	-38.23	-13.00	-25.23	H
3296.57	-31.38	12.00	11.79	-31.17	-13.00	-18.17	H
1648.12	-44.01	9.40	4.75	-39.36	-13.00	-26.36	V
2472.41	-44.39	10.60	8.39	-42.18	-13.00	-29.18	V
3296.57	-42.92	12.00	11.79	-42.71	-13.00	-29.71	V
The Worst Test Results Channel 190/836.6 MHz							
Frequency(MHz)	S	Ant(dBi)	Loss	PMea	Limit	Margin	Polarity
	G.Lev (dBm)			(dBm)	(dBm)	(dBm)	
1673.23	-40.40	9.50	4.76	-35.66	-13.00	-22.66	H
2509.65	-40.29	10.70	8.40	-37.99	-13.00	-24.99	H
3346.44	-31.50	12.20	11.80	-31.10	-13.00	-18.10	H
1673.23	-43.45	9.40	4.75	-38.80	-13.00	-25.80	V
2509.65	-44.44	10.60	8.39	-42.23	-13.00	-29.23	V
3346.44	-42.56	12.20	11.82	-42.18	-13.00	-29.18	V
The Worst Test Results Channel 251/848.8 MHz							
Frequency(MHz)	S	Ant(dBi)	Loss	PMea	Limit	Margin	Polarity
	G.Lev (dBm)			(dBm)	(dBm)	(dBm)	
1697.43	-40.60	9.60	4.77	-35.77	-13.00	-22.77	H
2546.47	-40.42	10.80	8.50	-38.12	-13.00	-25.12	H
3394.90	-32.00	12.50	11.90	-31.40	-13.00	-18.40	H
1697.43	-44.63	9.60	4.77	-39.80	-13.00	-26.80	V
2546.47	-44.30	10.80	8.50	-42.00	-13.00	-29.00	V
3394.90	-42.54	12.50	11.90	-41.94	-13.00	-28.94	V



EGPRS 850: (30-9000)MHz							
The Worst Test Results Channel 128/824.2 MHz							
Frequency(MHz)	S	Ant(dBi)	Loss	PMea	Limit	Margin	Polarity
	G.Lev (dBm)			(dBm)	(dBm)	(dBm)	
1648.37	-41.49	9.40	4.75	-36.84	-13.00	-23.84	H
2472.29	-39.36	10.60	8.39	-37.15	-13.00	-24.15	H
3296.74	-32.28	12.00	11.79	-32.07	-13.00	-19.07	H
1648.37	-43.79	9.40	4.75	-39.14	-13.00	-26.14	V
2472.29	-45.30	10.60	8.39	-43.09	-13.00	-30.09	V
3296.74	-42.83	12.00	11.79	-42.62	-13.00	-29.62	V
The Worst Test Results Channel 190/836.6 MHz							
Frequency(MHz)	S	Ant(dBi)	Loss	PMea	Limit	Margin	Polarity
	G.Lev (dBm)			(dBm)	(dBm)	(dBm)	
1673.24	-40.75	9.50	4.76	-36.01	-13.00	-23.01	H
2509.52	-40.00	10.70	8.40	-37.70	-13.00	-24.70	H
3346.37	-31.64	12.20	11.80	-31.24	-13.00	-18.24	H
1673.24	-43.21	9.40	4.75	-38.56	-13.00	-25.56	V
2509.52	-45.08	10.60	8.39	-42.87	-13.00	-29.87	V
3346.37	-43.04	12.20	11.82	-42.66	-13.00	-29.66	V
The Worst Test Results Channel 251/848.8 MHz							
Frequency(MHz)	S	Ant(dBi)	Loss	PMea	Limit	Margin	Polarity
	G.Lev (dBm)			(dBm)	(dBm)	(dBm)	
1697.25	-41.56	9.60	4.77	-36.73	-13.00	-23.73	H
2546.52	-39.23	10.80	8.50	-36.93	-13.00	-23.93	H
3395.24	-31.34	12.50	11.90	-30.74	-13.00	-17.74	H
1697.25	-43.93	9.60	4.77	-39.10	-13.00	-26.10	V
2546.52	-44.78	10.80	8.50	-42.48	-13.00	-29.48	V
3395.24	-43.81	12.50	11.90	-43.21	-13.00	-30.21	V



GPRS1900: (30-20000)MHz							
The Worst Test Results for Channel 512/1850.2MHz							
Frequency(MHz)	S G.Lev (dBm)	Ant(dBi)	Loss	PMea	Limit	Margin	Polarity
				(dBm)	(dBm)	(dBm)	
3700.43	-34.70	12.60	12.93	-35.03	-13.00	-22.03	H
5550.51	-35.31	13.10	17.11	-39.32	-13.00	-26.32	H
7400.85	-33.65	11.50	22.20	-44.35	-13.00	-31.35	H
3700.43	-35.33	12.60	12.93	-35.66	-13.00	-22.66	V
5550.51	-34.43	13.10	17.11	-38.44	-13.00	-25.44	V
7400.85	-32.94	11.50	22.20	-43.64	-13.00	-30.64	V
The Worst Test Results for Channel 661/1880.0MHz							
Frequency(MHz)	S G.Lev (dBm)	Ant(dBi)	Loss	PMea	Limit	Margin	Polarity
				(dBm)	(dBm)	(dBm)	
3759.83	-33.61	12.60	12.93	-33.94	-13.00	-20.94	H
5639.82	-34.48	13.10	17.11	-38.49	-13.00	-25.49	H
7520.19	-32.92	11.50	22.20	-43.62	-13.00	-30.62	H
3759.83	-35.80	12.60	12.93	-36.13	-13.00	-23.13	V
5639.82	-34.47	13.10	17.11	-38.48	-13.00	-25.48	V
7520.19	-32.62	11.50	22.20	-43.32	-13.00	-30.32	V
The Worst Test Results for Channel 810/1909.8MHz							
Frequency(MHz)	S G.Lev (dBm)	Ant(dBi)	Loss	PMea	Limit	Margin	Polarity
				(dBm)	(dBm)	(dBm)	
3819.29	-33.91	12.60	12.93	-34.24	-13.00	-21.24	H
5729.32	-34.18	13.10	17.11	-38.19	-13.00	-25.19	H
7639.22	-32.28	11.50	22.20	-42.98	-13.00	-29.98	H
3819.29	-34.76	12.60	12.93	-35.09	-13.00	-22.09	V
5729.32	-34.42	13.10	17.11	-38.43	-13.00	-25.43	V
7639.22	-32.84	11.50	22.20	-43.54	-13.00	-30.54	V



EGPRS 1900: (30-20000)MHz							
The Worst Test Results for Channel 512/1850.2MHz							
Frequency(MHz)	S	Ant(dBi)	Loss	PMea	Limit	Margin	Polarity
	G.Lev (dBm)			(dBm)	(dBm)	(dBm)	
3700.33	-34.29	12.60	12.93	-34.62	-13.00	-21.62	H
5550.57	-34.14	13.10	17.11	-38.15	-13.00	-25.15	H
7400.71	-33.58	11.50	22.20	-44.28	-13.00	-31.28	H
3700.33	-36.00	12.60	12.93	-36.33	-13.00	-23.33	V
5550.57	-33.82	13.10	17.11	-37.83	-13.00	-24.83	V
7400.71	-33.02	11.50	22.20	-43.72	-13.00	-30.72	V
The Worst Test Results for Channel 661/1880.0MHz							
Frequency(MHz)	S	Ant(dBi)	Loss	PMea	Limit	Margin	Polarity
	G.Lev (dBm)			(dBm)	(dBm)	(dBm)	
3759.85	-34.67	12.60	12.93	-35.00	-13.00	-22.00	H
5640.14	-34.23	13.10	17.11	-38.24	-13.00	-25.24	H
7519.94	-32.62	11.50	22.20	-43.32	-13.00	-30.32	H
3759.85	-35.10	12.60	12.93	-35.43	-13.00	-22.43	V
5640.14	-35.14	13.10	17.11	-39.15	-13.00	-26.15	V
7519.94	-32.18	11.50	22.20	-42.88	-13.00	-29.88	V
The Worst Test Results for Channel 810/1909.8MHz							
Frequency(MHz)	S	Ant(dBi)	Loss	PMea	Limit	Margin	Polarity
	G.Lev (dBm)			(dBm)	(dBm)	(dBm)	
3819.57	-33.80	12.60	12.93	-34.13	-13.00	-21.13	H
5729.33	-34.93	13.10	17.11	-38.94	-13.00	-25.94	H
7639.24	-32.27	11.50	22.20	-42.97	-13.00	-29.97	H
3819.57	-35.00	12.60	12.93	-35.33	-13.00	-22.33	V
5729.33	-35.12	13.10	17.11	-39.13	-13.00	-26.13	V
7639.24	-32.22	11.50	22.20	-42.92	-13.00	-29.92	V



WCDMA Band 2: (30-20000)MHz							
The Worst Test Results for Channel 9262/1852.4MHz							
Frequency(MHz)	S	Ant(dBi)	Loss	PMea	Limit	Margin	Polarity
	G.Lev (dBm)			(dBm)	(dBm)	(dBm)	
3704.43	-34.12	12.60	12.93	-34.45	-13.00	-21.45	H
5557.53	-35.46	13.10	17.11	-39.47	-13.00	-26.47	H
7409.58	-33.05	11.50	22.20	-43.75	-13.00	-30.75	H
3704.43	-35.05	12.60	12.93	-35.38	-13.00	-22.38	V
5557.53	-34.66	13.10	17.11	-38.67	-13.00	-25.67	V
7409.58	-31.90	11.50	22.20	-42.60	-13.00	-29.60	V
The Worst Test Results for Channel 9400/1880MHz							
Frequency(MHz)	S	Ant(dBi)	Loss	PMea	Limit	Margin	Polarity
	G.Lev (dBm)			(dBm)	(dBm)	(dBm)	
3760.08	-33.73	12.60	12.93	-34.06	-13.00	-21.06	H
5640.25	-34.75	13.10	17.11	-38.76	-13.00	-25.76	H
7520.05	-33.58	11.50	22.20	-44.28	-13.00	-31.28	H
3760.08	-35.06	12.60	12.93	-35.39	-13.00	-22.39	V
5640.25	-34.38	13.10	17.11	-38.39	-13.00	-25.39	V
7520.05	-31.72	11.50	22.20	-42.42	-13.00	-29.42	V
The Worst Test Results for Channel 9538/1907.6MHz							
Frequency(MHz)	S	Ant(dBi)	Loss	PMea	Limit	Margin	Polarity
	G.Lev (dBm)			(dBm)	(dBm)	(dBm)	
3815.25	-34.23	12.60	12.93	-34.56	-13.00	-21.56	H
5722.35	-35.10	13.10	17.11	-39.11	-13.00	-26.11	H
7629.88	-32.85	11.50	22.20	-43.55	-13.00	-30.55	H
3815.25	-35.15	12.60	12.93	-35.48	-13.00	-22.48	V
5722.35	-34.06	13.10	17.11	-38.07	-13.00	-25.07	V
7629.88	-33.17	11.50	22.20	-43.87	-13.00	-30.87	V





HSDPA Band 2: (30-20000)MHz							
The Worst Test Results for Channel 9262/1852.4MHz							
Frequency(MHz)	S	Ant(dBi)	Loss	PMea	Limit	Margin	Polarity
	G.Lev (dBm)			(dBm)	(dBm)	(dBm)	
3704.01	-34.02	12.60	12.93	-34.35	-13.00	-21.35	H
5557.27	-35.45	13.10	17.11	-39.46	-13.00	-26.46	H
7409.51	-33.55	11.50	22.20	-44.25	-13.00	-31.25	H
3704.01	-35.51	12.60	12.93	-35.84	-13.00	-22.84	V
5557.27	-33.87	13.10	17.11	-37.88	-13.00	-24.88	V
7409.51	-33.20	11.50	22.20	-43.90	-13.00	-30.90	V
The Worst Test Results for Channel 9400/1880MHz							
Frequency(MHz)	S	Ant(dBi)	Loss	PMea	Limit	Margin	Polarity
	G.Lev (dBm)			(dBm)	(dBm)	(dBm)	
3760.17	-34.10	12.60	12.93	-34.43	-13.00	-21.43	H
5640.09	-34.28	13.10	17.11	-38.29	-13.00	-25.29	H
7519.89	-32.41	11.50	22.20	-43.11	-13.00	-30.11	H
3760.17	-35.81	12.60	12.93	-36.14	-13.00	-23.14	V
5640.09	-34.62	13.10	17.11	-38.63	-13.00	-25.63	V
7519.89	-32.15	11.50	22.20	-42.85	-13.00	-29.85	V
The Worst Test Results for Channel 9538/1907.6MHz							
Frequency(MHz)	S	Ant(dBi)	Loss	PMea	Limit	Margin	Polarity
	G.Lev (dBm)			(dBm)	(dBm)	(dBm)	
3815.26	-33.93	12.60	12.93	-34.26	-13.00	-21.26	H
5722.06	-34.33	13.10	17.11	-38.34	-13.00	-25.34	H
7629.92	-32.24	11.50	22.20	-42.94	-13.00	-29.94	H
3815.26	-35.86	12.60	12.93	-36.19	-13.00	-23.19	V
5722.06	-34.01	13.10	17.11	-38.02	-13.00	-25.02	V
7629.92	-31.83	11.50	22.20	-42.53	-13.00	-29.53	V



HSUPA Band 2: (30-20000)MHz							
The Worst Test Results for Channel 9262/1852.4MHz							
Frequency(MHz)	S	Ant(dBi)	Loss	PMea	Limit	Margin	Polarity
	G.Lev (dBm)			(dBm)	(dBm)	(dBm)	
3704.40	-34.54	12.60	12.93	-34.87	-13.00	-21.87	H
5557.46	-35.39	13.10	17.11	-39.40	-13.00	-26.40	H
7409.73	-33.09	11.50	22.20	-43.79	-13.00	-30.79	H
3704.40	-35.56	12.60	12.93	-35.89	-13.00	-22.89	V
5557.46	-34.03	13.10	17.11	-38.04	-13.00	-25.04	V
7409.73	-32.67	11.50	22.20	-43.37	-13.00	-30.37	V
The Worst Test Results for Channel 9400/1880MHz							
Frequency(MHz)	S	Ant(dBi)	Loss	PMea	Limit	Margin	Polarity
	G.Lev (dBm)			(dBm)	(dBm)	(dBm)	
3759.84	-33.91	12.60	12.93	-34.24	-13.00	-21.24	H
5640.08	-34.60	13.10	17.11	-38.61	-13.00	-25.61	H
7520.10	-33.01	11.50	22.20	-43.71	-13.00	-30.71	H
3759.84	-34.69	12.60	12.93	-35.02	-13.00	-22.02	V
5640.08	-34.66	13.10	17.11	-38.67	-13.00	-25.67	V
7520.10	-32.82	11.50	22.20	-43.52	-13.00	-30.52	V
The Worst Test Results for Channel 9538/1907.6MHz							
Frequency(MHz)	S	Ant(dBi)	Loss	PMea	Limit	Margin	Polarity
	G.Lev (dBm)			(dBm)	(dBm)	(dBm)	
3815.58	-34.09	12.60	12.93	-34.42	-13.00	-21.42	H
5722.07	-34.14	13.10	17.11	-38.15	-13.00	-25.15	H
7630.00	-32.18	11.50	22.20	-42.88	-13.00	-29.88	H
3815.58	-35.36	12.60	12.93	-35.69	-13.00	-22.69	V
5722.07	-34.47	13.10	17.11	-38.48	-13.00	-25.48	V
7630.00	-32.87	11.50	22.20	-43.57	-13.00	-30.57	V



WCDMA Band 4: (30-18000)MHz							
The Worst Test Results for Channel 1312/1712.4MHz							
Frequency(MHz)	S	Ant(dBi)	Loss	PMea	Limit	Margin	Polarity
	G.Lev (dBm)			(dBm)	(dBm)	(dBm)	
3425.11	-34.81	12.90	12.05	-33.96	-13.00	-20.96	H
5137.42	-35.36	12.80	16.27	-38.83	-13.00	-25.83	H
6850.24	-32.22	12.30	20.13	-40.05	-13.00	-27.05	H
3425.11	-35.55	12.90	12.05	-34.70	-13.00	-21.70	V
5137.42	-34.49	12.80	16.27	-37.96	-13.00	-24.96	V
6850.24	-33.16	12.30	20.13	-40.99	-13.00	-27.99	V
The Worst Test Results for Channel 1450/1740.0MHz							
Frequency(MHz)	S	Ant(dBi)	Loss	PMea	Limit	Margin	Polarity
	G.Lev (dBm)			(dBm)	(dBm)	(dBm)	
3479.64	-34.18	12.90	12.05	-33.33	-13.00	-20.33	H
5219.53	-34.92	12.80	16.27	-38.39	-13.00	-25.39	H
6959.51	-32.74	12.30	20.13	-40.57	-13.00	-27.57	H
3479.64	-35.74	12.90	12.05	-34.89	-13.00	-21.89	V
5219.53	-34.99	12.80	16.27	-38.46	-13.00	-25.46	V
6959.51	-32.97	12.30	20.13	-40.80	-13.00	-27.80	V
The Worst Test Results for Channel 1513/1752.6MHz							
Frequency(MHz)	S	Ant(dBi)	Loss	PMea	Limit	Margin	Polarity
	G.Lev (dBm)			(dBm)	(dBm)	(dBm)	
3504.55	-33.89	12.90	12.05	-33.04	-13.00	-20.04	H
5256.79	-34.34	12.80	16.27	-37.81	-13.00	-24.81	H
7009.28	-33.23	12.30	20.13	-41.06	-13.00	-28.06	H
3504.55	-35.23	12.90	12.05	-34.38	-13.00	-21.38	V
5256.79	-34.29	12.80	16.27	-37.76	-13.00	-24.76	V
7009.28	-32.70	12.30	20.13	-40.53	-13.00	-27.53	V



HSDPA Band 4: (30-18000)MHz							
The Worst Test Results for Channel 1312/1712.4MHz							
Frequency(MHz)	S	Ant(dBi)	Loss	PMea	Limit	Margin	Polarity
	G.Lev (dBm)			(dBm)	(dBm)	(dBm)	
3424.94	-34.35	12.90	12.05	-33.50	-13.00	-20.50	H
5137.53	-35.29	12.80	16.27	-38.76	-13.00	-25.76	H
6849.94	-32.51	12.30	20.13	-40.34	-13.00	-27.34	H
3424.94	-36.02	12.90	12.05	-35.17	-13.00	-22.17	V
5137.53	-35.15	12.80	16.27	-38.62	-13.00	-25.62	V
6849.94	-32.70	12.30	20.13	-40.53	-13.00	-27.53	V
The Worst Test Results for Channel 1450/1740.0MHz							
Frequency(MHz)	S	Ant(dBi)	Loss	PMea	Limit	Margin	Polarity
	G.Lev (dBm)			(dBm)	(dBm)	(dBm)	
3479.67	-34.71	12.90	12.05	-33.86	-13.00	-20.86	H
5219.92	-35.15	12.80	16.27	-38.62	-13.00	-25.62	H
6959.65	-32.86	12.30	20.13	-40.69	-13.00	-27.69	H
3479.67	-35.80	12.90	12.05	-34.95	-13.00	-21.95	V
5219.92	-33.89	12.80	16.27	-37.36	-13.00	-24.36	V
6959.65	-31.74	12.30	20.13	-39.57	-13.00	-26.57	V
The Worst Test Results for Channel 1513/1752.6MHz							
Frequency(MHz)	S	Ant(dBi)	Loss	PMea	Limit	Margin	Polarity
	G.Lev (dBm)			(dBm)	(dBm)	(dBm)	
3504.56	-34.92	12.90	12.05	-34.07	-13.00	-21.07	H
5256.94	-34.64	12.80	16.27	-38.11	-13.00	-25.11	H
7009.56	-32.91	12.30	20.13	-40.74	-13.00	-27.74	H
3504.56	-35.22	12.90	12.05	-34.37	-13.00	-21.37	V
5256.94	-33.85	12.80	16.27	-37.32	-13.00	-24.32	V
7009.56	-32.34	12.30	20.13	-40.17	-13.00	-27.17	V



HSUPA Band 4: (30-18000)MHz							
The Worst Test Results for Channel 1312/1712.4MHz							
Frequency(MHz)	S	Ant(dBi)	Loss	PMea	Limit	Margin	Polarity
	G.Lev (dBm)			(dBm)	(dBm)	(dBm)	
3425.04	-34.89	12.90	12.05	-34.04	-13.00	-21.04	H
5137.34	-34.87	12.80	16.27	-38.34	-13.00	-25.34	H
6850.24	-33.08	12.30	20.13	-40.91	-13.00	-27.91	H
3425.04	-34.53	12.90	12.05	-33.68	-13.00	-20.68	V
5137.34	-34.84	12.80	16.27	-38.31	-13.00	-25.31	V
6850.24	-33.03	12.30	20.13	-40.86	-13.00	-27.86	V
The Worst Test Results for Channel 1450/1740.0MHz							
Frequency(MHz)	S	Ant(dBi)	Loss	PMea	Limit	Margin	Polarity
	G.Lev (dBm)			(dBm)	(dBm)	(dBm)	
3479.68	-33.95	12.90	12.05	-33.10	-13.00	-20.10	H
5219.72	-35.16	12.80	16.27	-38.63	-13.00	-25.63	H
6959.98	-32.41	12.30	20.13	-40.24	-13.00	-27.24	H
3479.68	-34.62	12.90	12.05	-33.77	-13.00	-20.77	V
5219.72	-34.40	12.80	16.27	-37.87	-13.00	-24.87	V
6959.98	-32.65	12.30	20.13	-40.48	-13.00	-27.48	V
The Worst Test Results for Channel 1513/1752.6MHz							
Frequency(MHz)	S	Ant(dBi)	Loss	PMea	Limit	Margin	Polarity
	G.Lev (dBm)			(dBm)	(dBm)	(dBm)	
3504.69	-33.92	12.90	12.05	-33.07	-13.00	-20.07	H
5257.05	-35.26	12.80	16.27	-38.73	-13.00	-25.73	H
7009.36	-33.09	12.30	20.13	-40.92	-13.00	-27.92	H
3504.69	-35.74	12.90	12.05	-34.89	-13.00	-21.89	V
5257.05	-33.93	12.80	16.27	-37.40	-13.00	-24.40	V
7009.36	-32.52	12.30	20.13	-40.35	-13.00	-27.35	V



WCDMA Band 5: (30-9000)MHz							
The most testresults channel 4132/826.4MHz							
Frequency(MHz)	S	Ant(dBi)	Loss	PMea	Limit	Margin	Polarity
	G.Lev (dBm)			(dBm)	(dBm)	(dBm)	
1652.47	-41.57	9.40	4.75	-36.92	-13.00	-23.92	H
2479.45	-40.56	10.60	8.39	-38.35	-13.00	-25.35	H
3305.85	-30.90	12.00	11.79	-30.69	-13.00	-17.69	H
1652.47	-43.55	9.40	4.75	-38.90	-13.00	-25.90	V
2479.45	-44.75	10.60	8.39	-42.54	-13.00	-29.54	V
3305.85	-42.83	12.00	11.79	-42.62	-13.00	-29.62	V
The Worst Test Results Channel 4182/836.4MHz							
Frequency(MHz)	S	Ant(dBi)	Loss	PMea	Limit	Margin	Polarity
	G.Lev (dBm)			(dBm)	(dBm)	(dBm)	
1673.26	-41.08	9.40	4.75	-36.43	-13.00	-23.43	H
2509.71	-40.63	10.60	8.39	-38.42	-13.00	-25.42	H
3346.32	-31.58	12.00	11.79	-31.37	-13.00	-18.37	H
1673.26	-44.32	9.40	4.75	-39.67	-13.00	-26.67	V
2509.71	-44.94	10.60	8.39	-42.73	-13.00	-29.73	V
3346.32	-43.62	12.00	11.79	-43.41	-13.00	-30.41	V
The Worst Test Results Channel 4233/846.6MHz							
Frequency(MHz)	S	Ant(dBi)	Loss	PMea	Limit	Margin	Polarity
	G.Lev (dBm)			(dBm)	(dBm)	(dBm)	
1693.47	-40.47	9.40	4.75	-35.82	-13.00	-22.82	H
2539.33	-39.54	10.60	8.39	-37.33	-13.00	-24.33	H
3386.14	-31.48	12.00	11.79	-31.27	-13.00	-18.27	H
1693.47	-44.35	9.40	4.75	-39.70	-13.00	-26.70	V
2539.33	-44.33	10.60	8.39	-42.12	-13.00	-29.12	V
3386.14	-43.45	12.00	11.79	-43.24	-13.00	-30.24	V





HSDPA Band 5: (30-9000)MHz							
The most testresults channel 4132/826.4MHz							
Frequency(MHz)	S	Ant(dBi)	Loss	PMea	Limit	Margin	Polarity
	G.Lev (dBm)			(dBm)	(dBm)	(dBm)	
1652.34	-41.09	9.40	4.75	-36.44	-13.00	-23.44	H
2479.55	-39.26	10.60	8.39	-37.05	-13.00	-24.05	H
3305.46	-31.18	12.00	11.79	-30.97	-13.00	-17.97	H
1652.34	-44.61	9.40	4.75	-39.96	-13.00	-26.96	V
2479.55	-45.13	10.60	8.39	-42.92	-13.00	-29.92	V
3305.46	-42.69	12.00	11.79	-42.48	-13.00	-29.48	V
The Worst Test Results Channel 4182/836.4MHz							
Frequency(MHz)	S	Ant(dBi)	Loss	PMea	Limit	Margin	Polarity
	G.Lev (dBm)			(dBm)	(dBm)	(dBm)	
1672.83	-41.47	9.40	4.75	-36.82	-13.00	-23.82	H
2509.85	-40.55	10.60	8.39	-38.34	-13.00	-25.34	H
3346.43	-31.96	12.00	11.79	-31.75	-13.00	-18.75	H
1672.83	-44.37	9.40	4.75	-39.72	-13.00	-26.72	V
2509.85	-45.03	10.60	8.39	-42.82	-13.00	-29.82	V
3346.43	-43.55	12.00	11.79	-43.34	-13.00	-30.34	V
The Worst Test Results Channel 4233/846.6MHz							
Frequency(MHz)	S	Ant(dBi)	Loss	PMea	Limit	Margin	Polarity
	G.Lev (dBm)			(dBm)	(dBm)	(dBm)	
1693.43	-40.57	9.40	4.75	-35.92	-13.00	-22.92	H
2539.35	-40.44	10.60	8.39	-38.23	-13.00	-25.23	H
3385.95	-30.97	12.00	11.79	-30.76	-13.00	-17.76	H
1693.43	-43.44	9.40	4.75	-38.79	-13.00	-25.79	V
2539.35	-44.44	10.60	8.39	-42.23	-13.00	-29.23	V
3385.95	-43.50	12.00	11.79	-43.29	-13.00	-30.29	V



HSUPA Band 5: (30-9000)MHz							
The most testresults channel 4132/826.4MHz							
Frequency(MHz)	S	Ant(dBi)	Loss	PMea	Limit	Margin	Polarity
	G.Lev (dBm)			(dBm)	(dBm)	(dBm)	
1652.42	-40.59	9.40	4.75	-35.94	-13.00	-22.94	H
2479.70	-39.23	10.60	8.39	-37.02	-13.00	-24.02	H
3305.60	-31.47	12.00	11.79	-31.26	-13.00	-18.26	H
1652.42	-43.64	9.40	4.75	-38.99	-13.00	-25.99	V
2479.70	-43.96	10.60	8.39	-41.75	-13.00	-28.75	V
3305.60	-42.83	12.00	11.79	-42.62	-13.00	-29.62	V
The Worst Test Results Channel 4182/836.4MHz							
Frequency(MHz)	S	Ant(dBi)	Loss	PMea	Limit	Margin	Polarity
	G.Lev (dBm)			(dBm)	(dBm)	(dBm)	
1672.85	-41.04	9.40	4.75	-36.39	-13.00	-23.39	H
2509.76	-39.56	10.60	8.39	-37.35	-13.00	-24.35	H
3346.13	-32.07	12.00	11.79	-31.86	-13.00	-18.86	H
1672.85	-44.39	9.40	4.75	-39.74	-13.00	-26.74	V
2509.76	-45.00	10.60	8.39	-42.79	-13.00	-29.79	V
3346.13	-43.44	12.00	11.79	-43.23	-13.00	-30.23	V
The Worst Test Results Channel 4233/846.6MHz							
Frequency(MHz)	S	Ant(dBi)	Loss	PMea	Limit	Margin	Polarity
	G.Lev (dBm)			(dBm)	(dBm)	(dBm)	
1693.54	-41.51	9.40	4.75	-36.86	-13.00	-23.86	H
2539.11	-39.89	10.60	8.39	-37.68	-13.00	-24.68	H
3386.07	-30.96	12.00	11.79	-30.75	-13.00	-17.75	H
1693.54	-43.46	9.40	4.75	-38.81	-13.00	-25.81	V
2539.11	-44.77	10.60	8.39	-42.56	-13.00	-29.56	V
3386.07	-42.50	12.00	11.79	-42.29	-13.00	-29.29	V



LTE Band 2 / 1.4MHz / QPSK / RB Size 1 Offset 0/ The Worst Test Results for Lowest							
Frequency(MHz)	S G.Lev (dBm)	Ant(dBi)	Loss	PMea	Limit	Margin	Polarity
				(dBm)	(dBm)	(dBm)	
3701.18	-34.20	12.60	12.93	-34.53	-13.00	-21.53	H
5551.85	-35.42	13.10	17.11	-39.43	-13.00	-26.43	H
7402.43	-33.03	11.50	22.20	-43.73	-13.00	-30.73	H
3701.18	-34.60	12.60	12.93	-34.93	-13.00	-21.93	V
5551.85	-34.79	13.10	17.11	-38.80	-13.00	-25.80	V
7402.43	-32.07	11.50	22.20	-42.77	-13.00	-29.77	V
LTE Band 2 / 1.4MHz / QPSK / RB Size 1 Offset 0/ The Worst Test Results for Middle							
Frequency(MHz)	S G.Lev (dBm)	Ant(dBi)	Loss	PMea	Limit	Margin	Polarity
				(dBm)	(dBm)	(dBm)	
3760.05	-33.47	12.60	12.93	-33.80	-13.00	-20.80	H
5640.21	-34.43	13.10	17.11	-38.44	-13.00	-25.44	H
7520.20	-33.22	11.50	22.20	-43.92	-13.00	-30.92	H
3760.05	-35.37	12.60	12.93	-35.70	-13.00	-22.70	V
5640.21	-34.79	13.10	17.11	-38.80	-13.00	-25.80	V
7520.20	-32.46	11.50	22.20	-43.16	-13.00	-30.16	V
LTE Band 2 / 1.4MHz / QPSK / RB Size 1 Offset 0/ The Worst Test Results for Highest							
Frequency(MHz)	S G.Lev (dBm)	Ant(dBi)	Loss	PMea	Limit	Margin	Polarity
				(dBm)	(dBm)	(dBm)	
3818.61	-33.50	12.60	12.93	-33.83	-13.00	-20.83	H
5727.44	-35.22	13.10	17.11	-39.23	-13.00	-26.23	H
7636.98	-33.09	11.50	22.20	-43.79	-13.00	-30.79	H
3818.61	-34.79	12.60	12.93	-35.12	-13.00	-22.12	V
5727.44	-34.11	13.10	17.11	-38.12	-13.00	-25.12	V
7636.98	-32.45	11.50	22.20	-43.15	-13.00	-30.15	V



LTE Band 2 / 3MHz / QPSK / RB Size 1 Offset 0/ The Worst Test Results for Lowest							
Frequency(MHz)	S G.Lev (dBm)	Ant(dBi)	Loss	PMea	Limit	Margin	Polarity
				(dBm)	(dBm)	(dBm)	
3703.21	-34.34	12.60	12.93	-34.67	-13.00	-21.67	H
5554.23	-34.29	13.10	17.11	-38.30	-13.00	-25.30	H
7405.91	-32.47	11.50	22.20	-43.17	-13.00	-30.17	H
3703.21	-34.77	12.60	12.93	-35.10	-13.00	-22.10	V
5554.23	-33.88	13.10	17.11	-37.89	-13.00	-24.89	V
7405.91	-32.02	11.50	22.20	-42.72	-13.00	-29.72	V
LTE Band 2 / 3MHz / QPSK / RB Size 1 Offset 0/ The Worst Test Results for Middle							
Frequency(MHz)	S G.Lev (dBm)	Ant(dBi)	Loss	PMea	Limit	Margin	Polarity
				(dBm)	(dBm)	(dBm)	
3760.14	-34.26	12.60	12.93	-34.59	-13.00	-21.59	H
5640.15	-34.40	13.10	17.11	-38.41	-13.00	-25.41	H
7520.05	-32.83	11.50	22.20	-43.53	-13.00	-30.53	H
3760.14	-35.66	12.60	12.93	-35.99	-13.00	-22.99	V
5640.15	-34.75	13.10	17.11	-38.76	-13.00	-25.76	V
7520.05	-32.58	11.50	22.20	-43.28	-13.00	-30.28	V
LTE Band 2 / 3MHz / QPSK / RB Size 1 Offset 0/ The Worst Test Results for Highest							
Frequency(MHz)	S G.Lev (dBm)	Ant(dBi)	Loss	PMea	Limit	Margin	Polarity
				(dBm)	(dBm)	(dBm)	
3817.12	-33.65	12.60	12.93	-33.98	-13.00	-20.98	H
5725.58	-34.33	13.10	17.11	-38.34	-13.00	-25.34	H
7634.29	-32.33	11.50	22.20	-43.03	-13.00	-30.03	H
3817.12	-35.06	12.60	12.93	-35.39	-13.00	-22.39	V
5725.58	-35.05	13.10	17.11	-39.06	-13.00	-26.06	V
7634.29	-32.07	11.50	22.20	-42.77	-13.00	-29.77	V



LTE Band 2 / 5MHz / QPSK / RB Size 1 Offset 0/ The Worst Test Results for Lowest							
Frequency(MHz)	S G.Lev (dBm)	Ant(dBi)	Loss	PMea	Limit	Margin	Polarity
				(dBm)	(dBm)	(dBm)	
3705.40	-33.49	12.60	12.93	-33.82	-13.00	-20.82	H
5557.08	-34.62	13.10	17.11	-38.63	-13.00	-25.63	H
7410.14	-32.69	11.50	22.20	-43.39	-13.00	-30.39	H
3705.40	-35.66	12.60	12.93	-35.99	-13.00	-22.99	V
5557.08	-34.69	13.10	17.11	-38.70	-13.00	-25.70	V
7410.14	-32.22	11.50	22.20	-42.92	-13.00	-29.92	V
LTE Band 2 / 5MHz / QPSK / RB Size 1 Offset 0/ The Worst Test Results for Middle							
Frequency(MHz)	S G.Lev (dBm)	Ant(dBi)	Loss	PMea	Limit	Margin	Polarity
				(dBm)	(dBm)	(dBm)	
3760.13	-34.16	12.60	12.93	-34.49	-13.00	-21.49	H
5639.80	-34.92	13.10	17.11	-38.93	-13.00	-25.93	H
7519.94	-33.05	11.50	22.20	-43.75	-13.00	-30.75	H
3760.13	-35.41	12.60	12.93	-35.74	-13.00	-22.74	V
5639.80	-34.52	13.10	17.11	-38.53	-13.00	-25.53	V
7519.94	-33.18	11.50	22.20	-43.88	-13.00	-30.88	V
LTE Band 2 / 5MHz / QPSK / RB Size 1 Offset 0/ The Worst Test Results for Highest							
Frequency(MHz)	S G.Lev (dBm)	Ant(dBi)	Loss	PMea	Limit	Margin	Polarity
				(dBm)	(dBm)	(dBm)	
3815.42	-34.05	12.60	12.93	-34.38	-13.00	-21.38	H
5722.17	-34.43	13.10	17.11	-38.44	-13.00	-25.44	H
7629.94	-33.09	11.50	22.20	-43.79	-13.00	-30.79	H
3815.42	-34.89	12.60	12.93	-35.22	-13.00	-22.22	V
5722.17	-35.21	13.10	17.11	-39.22	-13.00	-26.22	V
7629.94	-33.09	11.50	22.20	-43.79	-13.00	-30.79	V



LTE Band 2 / 10MHz / QPSK / RB Size 1 Offset 0/ The Worst Test Results for Lowest							
Frequency(MHz)	S G.Lev (dBm)	Ant(dBi)	Loss	PMea	Limit	Margin	Polarity
				(dBm)	(dBm)	(dBm)	
3710.48	-34.32	12.60	12.93	-34.65	-13.00	-21.65	H
5565.47	-34.58	13.10	17.11	-38.59	-13.00	-25.59	H
7419.91	-32.88	11.50	22.20	-43.58	-13.00	-30.58	H
3710.48	-35.80	12.60	12.93	-36.13	-13.00	-23.13	V
5565.47	-33.87	13.10	17.11	-37.88	-13.00	-24.88	V
7419.91	-32.92	11.50	22.20	-43.62	-13.00	-30.62	V
LTE Band 2 / 10MHz / QPSK / RB Size 1 Offset 0/ The Worst Test Results for Middle							
Frequency(MHz)	S G.Lev (dBm)	Ant(dBi)	Loss	PMea	Limit	Margin	Polarity
				(dBm)	(dBm)	(dBm)	
3759.78	-33.96	12.60	12.93	-34.29	-13.00	-21.29	H
5640.23	-34.55	13.10	17.11	-38.56	-13.00	-25.56	H
7519.97	-32.40	11.50	22.20	-43.10	-13.00	-30.10	H
3759.78	-35.06	12.60	12.93	-35.39	-13.00	-22.39	V
5640.23	-35.03	13.10	17.11	-39.04	-13.00	-26.04	V
7519.97	-31.99	11.50	22.20	-42.69	-13.00	-29.69	V
LTE Band 2 / 10MHz / QPSK / RB Size 1 Offset 0/ The Worst Test Results for Highest							
Frequency(MHz)	S G.Lev (dBm)	Ant(dBi)	Loss	PMea	Limit	Margin	Polarity
				(dBm)	(dBm)	(dBm)	
3810.20	-34.12	12.60	12.93	-34.45	-13.00	-21.45	H
5715.05	-34.61	13.10	17.11	-38.62	-13.00	-25.62	H
7619.90	-32.69	11.50	22.20	-43.39	-13.00	-30.39	H
3810.20	-34.73	12.60	12.93	-35.06	-13.00	-22.06	V
5715.05	-34.43	13.10	17.11	-38.44	-13.00	-25.44	V
7619.90	-32.61	11.50	22.20	-43.31	-13.00	-30.31	V





LTE Band 2 / 15MHz / QPSK / RB Size 1 Offset 0/ The Worst Test Results for Lowest							
Frequency(MHz)	S G.Lev (dBm)	Ant(dBi)	Loss	PMea	Limit	Margin	Polarity
				(dBm)	(dBm)	(dBm)	
3714.85	-34.14	12.60	12.93	-34.47	-13.00	-21.47	H
5572.52	-34.23	13.10	17.11	-38.24	-13.00	-25.24	H
7430.73	-33.08	11.50	22.20	-43.78	-13.00	-30.78	H
3714.85	-35.14	12.60	12.93	-35.47	-13.00	-22.47	V
5572.52	-34.51	13.10	17.11	-38.52	-13.00	-25.52	V
7430.73	-33.18	11.50	22.20	-43.88	-13.00	-30.88	V
LTE Band 2 / 15MHz / QPSK / RB Size 1 Offset 0/ The Worst Test Results for Middle							
Frequency(MHz)	S G.Lev (dBm)	Ant(dBi)	Loss	PMea	Limit	Margin	Polarity
				(dBm)	(dBm)	(dBm)	
3759.87	-34.58	12.60	12.93	-34.91	-13.00	-21.91	H
5640.29	-34.16	13.10	17.11	-38.17	-13.00	-25.17	H
7519.92	-33.40	11.50	22.20	-44.10	-13.00	-31.10	H
3759.87	-35.34	12.60	12.93	-35.67	-13.00	-22.67	V
5640.29	-34.88	13.10	17.11	-38.89	-13.00	-25.89	V
7519.92	-32.95	11.50	22.20	-43.65	-13.00	-30.65	V
LTE Band 2 / 15MHz / QPSK / RB Size 1 Offset 0/ The Worst Test Results for Highest							
Frequency(MHz)	S G.Lev (dBm)	Ant(dBi)	Loss	PMea	Limit	Margin	Polarity
				(dBm)	(dBm)	(dBm)	
3804.96	-34.93	12.60	12.93	-35.26	-13.00	-22.26	H
5707.61	-34.57	13.10	17.11	-38.58	-13.00	-25.58	H
7610.07	-33.45	11.50	22.20	-44.15	-13.00	-31.15	H
3804.96	-35.00	12.60	12.93	-35.33	-13.00	-22.33	V
5707.61	-35.23	13.10	17.11	-39.24	-13.00	-26.24	V
7610.07	-32.78	11.50	22.20	-43.48	-13.00	-30.48	V



LTE Band 2 / 20MHz / QPSK / RB Size 1 Offset 0/ The Worst Test Results for Lowest							
Frequency(MHz)	S G.Lev (dBm)	Ant(dBi)	Loss	PMea	Limit	Margin	Polarity
				(dBm)	(dBm)	(dBm)	
3720.46	-34.36	12.60	12.93	-34.69	-13.00	-21.69	H
5580.51	-35.45	13.10	17.11	-39.46	-13.00	-26.46	H
7439.69	-32.17	11.50	22.20	-42.87	-13.00	-29.87	H
3720.46	-36.00	12.60	12.93	-36.33	-13.00	-23.33	V
5580.51	-33.87	13.10	17.11	-37.88	-13.00	-24.88	V
7439.69	-32.55	11.50	22.20	-43.25	-13.00	-30.25	V
LTE Band 2 / 20MHz / QPSK / RB Size 1 Offset 0/ The Worst Test Results for Middle							
Frequency(MHz)	S G.Lev (dBm)	Ant(dBi)	Loss	PMea	Limit	Margin	Polarity
				(dBm)	(dBm)	(dBm)	
3759.86	-33.71	12.60	12.93	-34.04	-13.00	-21.04	H
5640.24	-34.20	13.10	17.11	-38.21	-13.00	-25.21	H
7520.00	-32.81	11.50	22.20	-43.51	-13.00	-30.51	H
3759.86	-35.86	12.60	12.93	-36.19	-13.00	-23.19	V
5640.24	-34.03	13.10	17.11	-38.04	-13.00	-25.04	V
7520.00	-33.04	11.50	22.20	-43.74	-13.00	-30.74	V
LTE Band 2 / 20MHz / QPSK / RB Size 1 Offset 0/ The Worst Test Results for Highest							
Frequency(MHz)	S G.Lev (dBm)	Ant(dBi)	Loss	PMea	Limit	Margin	Polarity
				(dBm)	(dBm)	(dBm)	
3799.97	-34.25	12.60	12.93	-34.58	-13.00	-21.58	H
5699.73	-34.57	13.10	17.11	-38.58	-13.00	-25.58	H
7600.18	-32.60	11.50	22.20	-43.30	-13.00	-30.30	H
3799.97	-34.92	12.60	12.93	-35.25	-13.00	-22.25	V
5699.73	-34.25	13.10	17.11	-38.26	-13.00	-25.26	V
7600.18	-31.76	11.50	22.20	-42.46	-13.00	-29.46	V



LTE Band 4 / 1.4MHz / QPSK / RB Size 1 Offset 0/ The Worst Test Results for Lowest							
Frequency(MHz)	S G.Lev (dBm)	Ant(dBi)	Loss	PMea	Limit	Margin	Polarity
				(dBm)	(dBm)	(dBm)	
3421.04	-33.51	12.90	12.56	-33.17	-13.00	-20.17	H
5131.79	-35.09	13.10	16.32	-38.31	-13.00	-25.31	H
6842.52	-32.53	12.33	21.13	-41.33	-13.00	-28.33	H
3421.04	-34.53	12.90	12.56	-34.19	-13.00	-21.19	V
5131.79	-34.76	13.10	16.32	-37.98	-13.00	-24.98	V
6842.52	-31.96	12.33	21.13	-40.76	-13.00	-27.76	V
LTE Band 4 / 1.4MHz / QPSK / RB Size 1 Offset 0/ The Worst Test Results for Middle							
Frequency(MHz)	S G.Lev (dBm)	Ant(dBi)	Loss	PMea	Limit	Margin	Polarity
				(dBm)	(dBm)	(dBm)	
3464.86	-34.66	12.90	12.56	-34.32	-13.00	-21.32	H
5196.69	-34.27	13.10	16.32	-37.49	-13.00	-24.49	H
6929.91	-32.28	12.33	21.13	-41.08	-13.00	-28.08	H
3464.86	-35.68	12.90	12.56	-35.34	-13.00	-22.34	V
5196.69	-33.85	13.10	16.32	-37.07	-13.00	-24.07	V
6929.91	-31.79	12.33	21.13	-40.59	-13.00	-27.59	V
LTE Band 4 / 1.4MHz / QPSK / RB Size 1 Offset 0/ The Worst Test Results for Highest							
Frequency(MHz)	S G.Lev (dBm)	Ant(dBi)	Loss	PMea	Limit	Margin	Polarity
				(dBm)	(dBm)	(dBm)	
3508.12	-34.76	12.90	12.56	-34.42	-13.00	-21.42	H
5262.34	-34.63	13.10	16.32	-37.85	-13.00	-24.85	H
7015.70	-33.17	12.33	21.13	-41.97	-13.00	-28.97	H
3508.12	-34.66	12.90	12.56	-34.32	-13.00	-21.32	V
5262.34	-34.56	13.10	16.32	-37.78	-13.00	-24.78	V
7015.70	-32.75	12.33	21.13	-41.55	-13.00	-28.55	V



LTE Band 4 / 3MHz / QPSK / RB Size 1 Offset 0/ The Worst Test Results for Lowest							
Frequency(MHz)	S G.Lev (dBm)	Ant(dBi)	Loss	PMea	Limit	Margin	Polarity
				(dBm)	(dBm)	(dBm)	
3424.09	-34.83	12.90	12.56	-34.49	-13.00	-21.49	H
5135.94	-34.67	13.10	16.32	-37.89	-13.00	-24.89	H
6848.55	-32.79	12.33	21.13	-41.59	-13.00	-28.59	H
3424.09	-34.53	12.90	12.56	-34.19	-13.00	-21.19	V
5135.94	-35.14	13.10	16.32	-38.36	-13.00	-25.36	V
6848.55	-32.63	12.33	21.13	-41.43	-13.00	-28.43	V
LTE Band 4 / 3MHz / QPSK / RB Size 1 Offset 0/ The Worst Test Results for Middle							
Frequency(MHz)	S G.Lev (dBm)	Ant(dBi)	Loss	PMea	Limit	Margin	Polarity
				(dBm)	(dBm)	(dBm)	
3464.63	-34.10	12.90	12.56	-33.76	-13.00	-20.76	H
5196.62	-34.68	13.10	16.32	-37.90	-13.00	-24.90	H
6929.74	-32.81	12.33	21.13	-41.61	-13.00	-28.61	H
3464.63	-35.09	12.90	12.56	-34.75	-13.00	-21.75	V
5196.62	-34.03	13.10	16.32	-37.25	-13.00	-24.25	V
6929.74	-33.20	12.33	21.13	-42.00	-13.00	-29.00	V
LTE Band 4 / 3MHz / QPSK / RB Size 1 Offset 0/ The Worst Test Results for Highest							
Frequency(MHz)	S G.Lev (dBm)	Ant(dBi)	Loss	PMea	Limit	Margin	Polarity
				(dBm)	(dBm)	(dBm)	
3506.26	-34.88	12.90	12.56	-34.54	-13.00	-21.54	H
5261.98	-35.20	13.10	16.32	-38.42	-13.00	-25.42	H
7012.40	-32.73	12.33	21.13	-41.53	-13.00	-28.53	H
3506.26	-35.75	12.90	12.56	-35.41	-13.00	-22.41	V
5261.98	-35.07	13.10	16.32	-38.29	-13.00	-25.29	V
7012.40	-32.25	12.33	21.13	-41.05	-13.00	-28.05	V



LTE Band 4 / 5MHz / QPSK / RB Size 1 Offset 0/ The Worst Test Results for Lowest							
Frequency(MHz)	S G.Lev (dBm)	Ant(dBi)	Loss	PMea	Limit	Margin	Polarity
				(dBm)	(dBm)	(dBm)	
3424.88	-34.49	12.90	12.56	-34.15	-13.00	-21.15	H
5137.23	-34.19	13.10	16.32	-37.41	-13.00	-24.41	H
6849.63	-33.48	12.33	21.13	-42.28	-13.00	-29.28	H
3424.88	-35.40	12.90	12.56	-35.06	-13.00	-22.06	V
5137.23	-35.12	13.10	16.32	-38.34	-13.00	-25.34	V
6849.63	-31.81	12.33	21.13	-40.61	-13.00	-27.61	V
LTE Band 4 / 5MHz / QPSK / RB Size 1 Offset 0/ The Worst Test Results for Middle							
Frequency(MHz)	S G.Lev (dBm)	Ant(dBi)	Loss	PMea	Limit	Margin	Polarity
				(dBm)	(dBm)	(dBm)	
3464.68	-34.81	12.90	12.56	-34.47	-13.00	-21.47	H
5196.87	-34.88	13.10	16.32	-38.10	-13.00	-25.10	H
6930.01	-32.40	12.33	21.13	-41.20	-13.00	-28.20	H
3464.68	-35.77	12.90	12.56	-35.43	-13.00	-22.43	V
5196.87	-35.06	13.10	16.32	-38.28	-13.00	-25.28	V
6930.01	-33.02	12.33	21.13	-41.82	-13.00	-28.82	V
LTE Band 4 / 5MHz / QPSK / RB Size 1 Offset 0/ The Worst Test Results for Highest							
Frequency(MHz)	S G.Lev (dBm)	Ant(dBi)	Loss	PMea	Limit	Margin	Polarity
				(dBm)	(dBm)	(dBm)	
3504.99	-33.78	12.90	12.56	-33.44	-13.00	-20.44	H
5256.87	-34.29	13.10	16.32	-37.51	-13.00	-24.51	H
7009.71	-32.17	12.33	21.13	-40.97	-13.00	-27.97	H
3504.99	-35.36	12.90	12.56	-35.02	-13.00	-22.02	V
5256.87	-35.11	13.10	16.32	-38.33	-13.00	-25.33	V
7009.71	-32.96	12.33	21.13	-41.76	-13.00	-28.76	V



LTE Band 4 / 10MHz / QPSK / RB Size 1 Offset 0/ The Worst Test Results for Lowest							
Frequency(MHz)	S G.Lev (dBm)	Ant(dBi)	Loss	PMea	Limit	Margin	Polarity
				(dBm)	(dBm)	(dBm)	
3430.00	-33.57	12.90	12.56	-33.23	-13.00	-20.23	H
5145.03	-35.30	13.10	16.32	-38.52	-13.00	-25.52	H
6860.46	-32.85	12.33	21.13	-41.65	-13.00	-28.65	H
3430.00	-35.51	12.90	12.56	-35.17	-13.00	-22.17	V
5145.03	-34.71	13.10	16.32	-37.93	-13.00	-24.93	V
6860.46	-32.82	12.33	21.13	-41.62	-13.00	-28.62	V
LTE Band 4 / 10MHz / QPSK / RB Size 1 Offset 0/ The Worst Test Results for Middle							
Frequency(MHz)	S G.Lev (dBm)	Ant(dBi)	Loss	PMea	Limit	Margin	Polarity
				(dBm)	(dBm)	(dBm)	
3464.38	-34.23	12.90	12.56	-33.89	-13.00	-20.89	H
5196.46	-35.16	13.10	16.32	-38.38	-13.00	-25.38	H
6929.46	-32.89	12.33	21.13	-41.69	-13.00	-28.69	H
3464.38	-35.67	12.90	12.56	-35.33	-13.00	-22.33	V
5196.46	-34.85	13.10	16.32	-38.07	-13.00	-25.07	V
6929.46	-32.33	12.33	21.13	-41.13	-13.00	-28.13	V
LTE Band 4 / 10MHz / QPSK / RB Size 1 Offset 0/ The Worst Test Results for Highest							
Frequency(MHz)	S G.Lev (dBm)	Ant(dBi)	Loss	PMea	Limit	Margin	Polarity
				(dBm)	(dBm)	(dBm)	
3500.29	-34.35	12.90	12.56	-34.01	-13.00	-21.01	H
5249.99	-34.94	13.10	16.32	-38.16	-13.00	-25.16	H
7000.12	-32.75	12.33	21.13	-41.55	-13.00	-28.55	H
3500.29	-35.76	12.90	12.56	-35.42	-13.00	-22.42	V
5249.99	-34.22	13.10	16.32	-37.44	-13.00	-24.44	V
7000.12	-31.91	12.33	21.13	-40.71	-13.00	-27.71	V





LTE Band 4 / 15MHz / QPSK / RB Size 1 Offset 0/ The Worst Test Results for Lowest							
Frequency(MHz)	S G.Lev (dBm)	Ant(dBi)	Loss	PMea	Limit	Margin	Polarity
				(dBm)	(dBm)	(dBm)	
3435.06	-34.67	12.90	12.56	-34.33	-13.00	-21.33	H
5152.37	-34.89	13.10	16.32	-38.11	-13.00	-25.11	H
6870.34	-32.31	12.33	21.13	-41.11	-13.00	-28.11	H
3435.06	-35.21	12.90	12.56	-34.87	-13.00	-21.87	V
5152.37	-34.36	13.10	16.32	-37.58	-13.00	-24.58	V
6870.34	-32.67	12.33	21.13	-41.47	-13.00	-28.47	V
LTE Band 4 / 15MHz / QPSK / RB Size 1 Offset 0/ The Worst Test Results for Middle							
Frequency(MHz)	S G.Lev (dBm)	Ant(dBi)	Loss	PMea	Limit	Margin	Polarity
				(dBm)	(dBm)	(dBm)	
3464.90	-33.50	12.90	12.56	-33.16	-13.00	-20.16	H
5196.79	-35.11	13.10	16.32	-38.33	-13.00	-25.33	H
6930.14	-33.42	12.33	21.13	-42.22	-13.00	-29.22	H
3464.90	-35.17	12.90	12.56	-34.83	-13.00	-21.83	V
5196.79	-35.05	13.10	16.32	-38.27	-13.00	-25.27	V
6930.14	-33.19	12.33	21.13	-41.99	-13.00	-28.99	V
LTE Band 4 / 15MHz / QPSK / RB Size 1 Offset 0/ The Worst Test Results for Highest							
Frequency(MHz)	S G.Lev (dBm)	Ant(dBi)	Loss	PMea	Limit	Margin	Polarity
				(dBm)	(dBm)	(dBm)	
3495.43	-33.87	12.90	12.56	-33.53	-13.00	-20.53	H
5241.94	-35.08	13.10	16.32	-38.30	-13.00	-25.30	H
6990.18	-32.29	12.33	21.13	-41.09	-13.00	-28.09	H
3495.43	-34.55	12.90	12.56	-34.21	-13.00	-21.21	V
5241.94	-33.77	13.10	16.32	-36.99	-13.00	-23.99	V
6990.18	-32.35	12.33	21.13	-41.15	-13.00	-28.15	V



LTE Band 4 / 20MHz / QPSK / RB Size 1 Offset 0/ The Worst Test Results for Lowest							
Frequency(MHz)	S G.Lev (dBm)	Ant(dBi)	Loss	PMea	Limit	Margin	Polarity
				(dBm)	(dBm)	(dBm)	
3440.02	-34.07	12.90	12.56	-33.73	-13.00	-20.73	H
5159.86	-34.26	13.10	16.32	-37.48	-13.00	-24.48	H
6880.49	-32.49	12.33	21.13	-41.29	-13.00	-28.29	H
3440.02	-34.93	12.90	12.56	-34.59	-13.00	-21.59	V
5159.86	-35.14	13.10	16.32	-38.36	-13.00	-25.36	V
6880.49	-32.58	12.33	21.13	-41.38	-13.00	-28.38	V
LTE Band 4 / 20MHz / QPSK / RB Size 1 Offset 0/ The Worst Test Results for Middle							
Frequency(MHz)	S G.Lev (dBm)	Ant(dBi)	Loss	PMea	Limit	Margin	Polarity
				(dBm)	(dBm)	(dBm)	
3464.97	-34.26	12.90	12.56	-33.92	-13.00	-20.92	H
5196.67	-34.69	13.10	16.32	-37.91	-13.00	-24.91	H
6929.87	-33.11	12.33	21.13	-41.91	-13.00	-28.91	H
3464.97	-34.92	12.90	12.56	-34.58	-13.00	-21.58	V
5196.67	-34.34	13.10	16.32	-37.56	-13.00	-24.56	V
6929.87	-32.10	12.33	21.13	-40.90	-13.00	-27.90	V
LTE Band 4 / 20MHz / QPSK / RB Size 1 Offset 0/ The Worst Test Results for Highest							
Frequency(MHz)	S G.Lev (dBm)	Ant(dBi)	Loss	PMea	Limit	Margin	Polarity
				(dBm)	(dBm)	(dBm)	
3490.29	-34.28	12.90	12.56	-33.94	-13.00	-20.94	H
5235.13	-34.83	13.10	16.32	-38.05	-13.00	-25.05	H
6979.62	-32.30	12.33	21.13	-41.10	-13.00	-28.10	H
3490.29	-35.69	12.90	12.56	-35.35	-13.00	-22.35	V
5235.13	-34.66	13.10	16.32	-37.88	-13.00	-24.88	V
6979.62	-32.42	12.33	21.13	-41.22	-13.00	-28.22	V



LTE Band 5 / 1.4MHz / QPSK / RB Size 1 Offset 0/ The Worst Test Results for Lowest							
Frequency(MHz)	S G.Lev (dBm)	Ant(dBi)	Loss	PMea	Limit	Margin	Polarity
				(dBm)	(dBm)	(dBm)	
1648.70	-34.38	9.56	9.72	-34.54	-13.00	-21.54	H
2473.66	-34.99	10.50	10.86	-35.35	-13.00	-22.35	H
3298.46	-32.74	12.78	11.57	-31.53	-13.00	-18.53	H
1648.70	-35.00	9.56	9.72	-35.16	-13.00	-22.16	V
2473.66	-34.06	10.50	10.86	-34.42	-13.00	-21.42	V
3298.46	-32.13	12.78	11.57	-30.92	-13.00	-17.92	V
LTE Band 5 / 1.4MHz / QPSK / RB Size 1 Offset 0/ The Worst Test Results for Middle							
Frequency(MHz)	S G.Lev (dBm)	Ant(dBi)	Loss	PMea	Limit	Margin	Polarity
				(dBm)	(dBm)	(dBm)	
1672.74	-33.66	9.56	9.72	-33.82	-13.00	-20.82	H
2509.15	-35.06	10.50	10.86	-35.42	-13.00	-22.42	H
3345.42	-32.22	12.78	11.57	-31.01	-13.00	-18.01	H
1672.74	-35.56	9.56	9.72	-35.72	-13.00	-22.72	V
2509.15	-34.57	10.50	10.86	-34.93	-13.00	-21.93	V
3345.42	-32.23	12.78	11.57	-31.02	-13.00	-18.02	V
LTE Band 5 / 1.4MHz / QPSK / RB Size 1 Offset 0/ The Worst Test Results for Highest							
Frequency(MHz)	S G.Lev (dBm)	Ant(dBi)	Loss	PMea	Limit	Margin	Polarity
				(dBm)	(dBm)	(dBm)	
1696.09	-34.11	9.56	9.72	-34.27	-13.00	-21.27	H
2544.31	-34.70	10.50	10.86	-35.06	-13.00	-22.06	H
3392.73	-33.29	12.78	11.57	-32.08	-13.00	-19.08	H
1696.09	-35.69	9.56	9.72	-35.85	-13.00	-22.85	V
2544.31	-34.48	10.50	10.86	-34.84	-13.00	-21.84	V
3392.73	-32.05	12.78	11.57	-30.84	-13.00	-17.84	V



LTE Band 5 / 3MHz / QPSK / RB Size 1 Offset 0/ The Worst Test Results for Lowest							
Frequency(MHz)	S G.Lev (dBm)	Ant(dBi)	Loss	PMea	Limit	Margin	Polarity
				(dBm)	(dBm)	(dBm)	
1650.39	-34.01	9.56	9.72	-34.17	-13.00	-21.17	H
2476.16	-35.09	10.50	10.86	-35.45	-13.00	-22.45	H
3301.43	-32.51	12.78	11.57	-31.30	-13.00	-18.30	H
1650.39	-35.38	9.56	9.72	-35.54	-13.00	-22.54	V
2476.16	-34.12	10.50	10.86	-34.48	-13.00	-21.48	V
3301.43	-32.13	12.78	11.57	-30.92	-13.00	-17.92	V
LTE Band 5 / 3MHz / QPSK / RB Size 1 Offset 0/ The Worst Test Results for Middle							
Frequency(MHz)	S G.Lev (dBm)	Ant(dBi)	Loss	PMea	Limit	Margin	Polarity
				(dBm)	(dBm)	(dBm)	
1672.09	-34.42	9.56	9.72	-34.58	-13.00	-21.58	H
2509.01	-35.41	10.50	10.86	-35.77	-13.00	-22.77	H
3345.73	-33.25	12.78	11.57	-32.04	-13.00	-19.04	H
1672.09	-35.71	9.56	9.72	-35.87	-13.00	-22.87	V
2509.01	-34.48	10.50	10.86	-34.84	-13.00	-21.84	V
3345.73	-32.76	12.78	11.57	-31.55	-13.00	-18.55	V
LTE Band 5 / 3MHz / QPSK / RB Size 1 Offset 0/ The Worst Test Results for Highest							
Frequency(MHz)	S G.Lev (dBm)	Ant(dBi)	Loss	PMea	Limit	Margin	Polarity
				(dBm)	(dBm)	(dBm)	
1694.44	-34.19	9.56	9.72	-34.35	-13.00	-21.35	H
2541.85	-34.56	10.50	10.86	-34.92	-13.00	-21.92	H
3389.08	-32.68	12.78	11.57	-31.47	-13.00	-18.47	H
1694.44	-34.60	9.56	9.72	-34.76	-13.00	-21.76	V
2541.85	-33.80	10.50	10.86	-34.16	-13.00	-21.16	V
3389.08	-31.89	12.78	11.57	-30.68	-13.00	-17.68	V



LTE Band 5 / 5MHz / QPSK / RB Size 1 Offset 0/ The Worst Test Results for Lowest							
Frequency(MHz)	S G.Lev (dBm)	Ant(dBi)	Loss	PMea	Limit	Margin	Polarity
				(dBm)	(dBm)	(dBm)	
1652.51	-33.87	9.56	9.72	-34.03	-13.00	-21.03	H
2478.98	-34.25	10.50	10.86	-34.61	-13.00	-21.61	H
3305.75	-33.41	12.78	11.57	-32.20	-13.00	-19.20	H
1652.51	-34.60	9.56	9.72	-34.76	-13.00	-21.76	V
2478.98	-34.79	10.50	10.86	-35.15	-13.00	-22.15	V
3305.75	-31.92	12.78	11.57	-30.71	-13.00	-17.71	V
LTE Band 5 / 5MHz / QPSK / RB Size 1 Offset 0/ The Worst Test Results for Middle							
Frequency(MHz)	S G.Lev (dBm)	Ant(dBi)	Loss	PMea	Limit	Margin	Polarity
				(dBm)	(dBm)	(dBm)	
1672.29	-33.46	9.56	9.72	-33.62	-13.00	-20.62	H
2508.87	-34.24	10.50	10.86	-34.60	-13.00	-21.60	H
3345.39	-32.90	12.78	11.57	-31.69	-13.00	-18.69	H
1672.29	-34.97	9.56	9.72	-35.13	-13.00	-22.13	V
2508.87	-34.53	10.50	10.86	-34.89	-13.00	-21.89	V
3345.39	-32.84	12.78	11.57	-31.63	-13.00	-18.63	V
LTE Band 5 / 5MHz / QPSK / RB Size 1 Offset 0/ The Worst Test Results for Highest							
Frequency(MHz)	S G.Lev (dBm)	Ant(dBi)	Loss	PMea	Limit	Margin	Polarity
				(dBm)	(dBm)	(dBm)	
1692.49	-34.06	9.56	9.72	-34.22	-13.00	-21.22	H
2539.04	-35.37	10.50	10.86	-35.73	-13.00	-22.73	H
3385.79	-33.30	12.78	11.57	-32.09	-13.00	-19.09	H
1692.49	-35.69	9.56	9.72	-35.85	-13.00	-22.85	V
2539.04	-33.83	10.50	10.86	-34.19	-13.00	-21.19	V
3385.79	-32.92	12.78	11.57	-31.71	-13.00	-18.71	V



LTE Band 5 / 10MHz / QPSK / RB Size 1 Offset 0/ The Worst Test Results for Lowest							
Frequency(MHz)	S G.Lev (dBm)	Ant(dBi)	Loss	PMea	Limit	Margin	Polarity
				(dBm)	(dBm)	(dBm)	
1657.86	-34.43	9.56	9.72	-34.59	-13.00	-21.59	H
2486.10	-34.51	10.50	10.86	-34.87	-13.00	-21.87	H
3315.14	-33.06	12.78	11.57	-31.85	-13.00	-18.85	H
1657.86	-35.95	9.56	9.72	-36.11	-13.00	-23.11	V
2486.10	-34.16	10.50	10.86	-34.52	-13.00	-21.52	V
3315.14	-31.92	12.78	11.57	-30.71	-13.00	-17.71	V
LTE Band 5 / 10MHz / QPSK / RB Size 1 Offset 0/ The Worst Test Results for Middle							
Frequency(MHz)	S G.Lev (dBm)	Ant(dBi)	Loss	PMea	Limit	Margin	Polarity
				(dBm)	(dBm)	(dBm)	
1672.15	-33.49	9.56	9.72	-33.65	-13.00	-20.65	H
2509.02	-34.53	10.50	10.86	-34.89	-13.00	-21.89	H
3345.39	-33.22	12.78	11.57	-32.01	-13.00	-19.01	H
1672.15	-35.51	9.56	9.72	-35.67	-13.00	-22.67	V
2509.02	-34.43	10.50	10.86	-34.79	-13.00	-21.79	V
3345.39	-32.93	12.78	11.57	-31.72	-13.00	-18.72	V
LTE Band 5 / 10MHz / QPSK / RB Size 1 Offset 0/ The Worst Test Results for Highest							
Frequency(MHz)	S G.Lev (dBm)	Ant(dBi)	Loss	PMea	Limit	Margin	Polarity
				(dBm)	(dBm)	(dBm)	
1687.34	-33.99	9.56	9.72	-34.15	-13.00	-21.15	H
2531.59	-35.25	10.50	10.86	-35.61	-13.00	-22.61	H
3375.45	-33.38	12.78	11.57	-32.17	-13.00	-19.17	H
1687.34	-35.23	9.56	9.72	-35.39	-13.00	-22.39	V
2531.59	-34.08	10.50	10.86	-34.44	-13.00	-21.44	V
3375.45	-32.12	12.78	11.57	-30.91	-13.00	-17.91	V





LTE Band 7 / 5MHz / QPSK / RB Size 1 Offset 0/ The Worst Test Results for Lowest							
Frequency(MHz)	S G.Lev (dBm)	Ant(dBi)	Loss	PMea	Limit	Margin	Polarity
				(dBm)	(dBm)	(dBm)	
5005.13	-33.52	12.66	15.86	-36.72	-25.00	-11.72	H
7507.51	-34.91	11.46	19.28	-42.73	-25.00	-17.73	H
10010.56	-32.28	12.79	23.19	-42.68	-25.00	-17.68	H
5005.13	-35.08	12.66	15.86	-38.28	-25.00	-13.28	V
7507.51	-35.00	11.46	19.28	-42.82	-25.00	-17.82	V
10010.56	-31.80	12.79	23.19	-42.20	-25.00	-17.20	V
LTE Band 7 / 5MHz / QPSK / RB Size 1 Offset 0/ The Worst Test Results for Middle							
Frequency(MHz)	S G.Lev (dBm)	Ant(dBi)	Loss	PMea	Limit	Margin	Polarity
				(dBm)	(dBm)	(dBm)	
5069.71	-34.27	12.72	15.86	-37.41	-25.00	-12.41	H
7604.74	-35.19	11.46	19.28	-43.01	-25.00	-18.01	H
10139.90	-32.72	12.09	23.19	-43.82	-25.00	-18.82	H
5069.71	-35.37	12.72	15.86	-38.51	-25.00	-13.51	V
7604.74	-34.34	11.46	19.28	-42.16	-25.00	-17.16	V
10139.90	-32.62	12.09	23.19	-43.72	-25.00	-18.72	V
LTE Band 7 / 5MHz / QPSK / RB Size 1 Offset 0/ The Worst Test Results for Highest							
Frequency(MHz)	S G.Lev (dBm)	Ant(dBi)	Loss	PMea	Limit	Margin	Polarity
				(dBm)	(dBm)	(dBm)	
5133.71	-34.83	12.76	15.86	-37.93	-25.00	-12.93	H
7701.35	-35.37	11.45	19.28	-43.20	-25.00	-18.20	H
10268.05	-32.24	12.28	23.19	-43.15	-25.00	-18.15	H
5133.71	-35.52	12.76	15.86	-38.62	-25.00	-13.62	V
7701.35	-34.09	11.45	19.28	-41.92	-25.00	-16.92	V
10268.05	-33.00	12.28	23.19	-43.91	-25.00	-18.91	V



LTE Band 7 / 10MHz / QPSK / RB Size 1 Offset 0/ The Worst Test Results for Lowest							
Frequency(MHz)	S G.Lev (dBm)	Ant(dBi)	Loss	PMea	Limit	Margin	Polarity
				(dBm)	(dBm)	(dBm)	
5010.13	-33.46	12.66	15.86	-36.66	-25.00	-11.66	H
7515.45	-35.34	11.46	19.28	-43.16	-25.00	-18.16	H
10020.58	-32.37	12.79	23.19	-42.77	-25.00	-17.77	H
5010.13	-34.61	12.66	15.86	-37.81	-25.00	-12.81	V
7515.45	-35.01	11.46	19.28	-42.83	-25.00	-17.83	V
10020.58	-33.16	12.79	23.19	-43.56	-25.00	-18.56	V
LTE Band 7 / 10MHz / QPSK / RB Size 1 Offset 0/ The Worst Test Results for Middle							
Frequency(MHz)	S G.Lev (dBm)	Ant(dBi)	Loss	PMea	Limit	Margin	Polarity
				(dBm)	(dBm)	(dBm)	
5069.61	-33.55	12.72	15.86	-36.69	-25.00	-11.69	H
7605.06	-34.48	11.46	19.28	-42.30	-25.00	-17.30	H
10139.94	-33.44	12.09	23.19	-44.54	-25.00	-19.54	H
5069.61	-35.45	12.72	15.86	-38.59	-25.00	-13.59	V
7605.06	-34.89	11.46	19.28	-42.71	-25.00	-17.71	V
10139.94	-32.75	12.09	23.19	-43.85	-25.00	-18.85	V
LTE Band 7 / 10MHz / QPSK / RB Size 1 Offset 0/ The Worst Test Results for Highest							
Frequency(MHz)	S G.Lev (dBm)	Ant(dBi)	Loss	PMea	Limit	Margin	Polarity
				(dBm)	(dBm)	(dBm)	
5129.25	-34.18	12.76	15.86	-37.28	-25.00	-12.28	H
7693.73	-34.63	11.45	19.28	-42.46	-25.00	-17.46	H
10258.58	-32.85	12.28	23.19	-43.76	-25.00	-18.76	H
5129.25	-35.53	12.76	15.86	-38.63	-25.00	-13.63	V
7693.73	-34.75	11.45	19.28	-42.58	-25.00	-17.58	V
10258.58	-32.31	12.28	23.19	-43.22	-25.00	-18.22	V



LTE Band 7 / 15MHz / QPSK / RB Size 1 Offset 0/ The Worst Test Results for Lowest							
Frequency(MHz)	S G.Lev (dBm)	Ant(dBi)	Loss	PMea	Limit	Margin	Polarity
				(dBm)	(dBm)	(dBm)	
5015.55	-34.35	12.66	15.86	-37.55	-25.00	-12.55	H
7523.96	-35.14	11.46	19.28	-42.96	-25.00	-17.96	H
10031.48	-33.59	12.79	23.19	-43.99	-25.00	-18.99	H
5015.55	-35.19	12.66	15.86	-38.39	-25.00	-13.39	V
7523.96	-34.83	11.46	19.28	-42.65	-25.00	-17.65	V
10031.48	-31.75	12.79	23.19	-42.15	-25.00	-17.15	V
LTE Band 7 / 15MHz / QPSK / RB Size 1 Offset 0/ The Worst Test Results for Middle							
Frequency(MHz)	S G.Lev (dBm)	Ant(dBi)	Loss	PMea	Limit	Margin	Polarity
				(dBm)	(dBm)	(dBm)	
5069.97	-34.27	12.72	15.86	-37.41	-25.00	-12.41	H
7604.85	-35.12	11.46	19.28	-42.94	-25.00	-17.94	H
10139.62	-32.28	12.09	23.19	-43.38	-25.00	-18.38	H
5069.97	-34.68	12.72	15.86	-37.82	-25.00	-12.82	V
7604.85	-34.79	11.46	19.28	-42.61	-25.00	-17.61	V
10139.62	-32.15	12.09	23.19	-43.25	-25.00	-18.25	V
LTE Band 7 / 15MHz / QPSK / RB Size 1 Offset 0/ The Worst Test Results for Highest							
Frequency(MHz)	S G.Lev (dBm)	Ant(dBi)	Loss	PMea	Limit	Margin	Polarity
				(dBm)	(dBm)	(dBm)	
5123.21	-34.14	12.76	15.86	-37.24	-25.00	-12.24	H
7523.97	-35.12	11.45	19.28	-42.95	-25.00	-17.95	H
10031.94	-33.42	12.28	23.19	-44.33	-25.00	-19.33	H
5123.21	-35.88	12.76	15.86	-38.98	-25.00	-13.98	V
7523.97	-34.38	11.45	19.28	-42.21	-25.00	-17.21	V
10031.94	-32.10	12.28	23.19	-43.01	-25.00	-18.01	V



LTE Band 7 / 20MHz / QPSK / RB Size 1 Offset 0/ The Worst Test Results for Lowest							
Frequency(MHz)	S G.Lev (dBm)	Ant(dBi)	Loss	PMea	Limit	Margin	Polarity
				(dBm)	(dBm)	(dBm)	
5020.95	-33.65	12.66	15.86	-36.85	-25.00	-11.85	H
7531.19	-34.44	11.46	19.28	-42.26	-25.00	-17.26	H
10258.85	-32.29	12.79	23.19	-42.69	-25.00	-17.69	H
5020.95	-35.64	12.66	15.86	-38.84	-25.00	-13.84	V
7531.19	-34.55	11.46	19.28	-42.37	-25.00	-17.37	V
10258.85	-32.54	12.79	23.19	-42.94	-25.00	-17.94	V
LTE Band 7 / 20MHz / QPSK / RB Size 1 Offset 0/ The Worst Test Results for Middle							
Frequency(MHz)	S G.Lev (dBm)	Ant(dBi)	Loss	PMea	Limit	Margin	Polarity
				(dBm)	(dBm)	(dBm)	
5069.92	-34.44	12.72	15.86	-37.58	-25.00	-12.58	H
7605.04	-35.23	11.46	19.28	-43.05	-25.00	-18.05	H
10139.98	-32.28	12.09	23.19	-43.38	-25.00	-18.38	H
5069.92	-35.32	12.72	15.86	-38.46	-25.00	-13.46	V
7605.04	-34.34	11.46	19.28	-42.16	-25.00	-17.16	V
10139.98	-32.97	12.09	23.19	-44.07	-25.00	-19.07	V
LTE Band 7 / 20MHz / QPSK / RB Size 1 Offset 0/ The Worst Test Results for Highest							
Frequency(MHz)	S G.Lev (dBm)	Ant(dBi)	Loss	PMea	Limit	Margin	Polarity
				(dBm)	(dBm)	(dBm)	
5118.57	-34.10	12.76	15.86	-37.20	-25.00	-12.20	H
7678.03	-34.42	11.45	19.28	-42.25	-25.00	-17.25	H
10237.97	-33.02	12.28	23.19	-43.93	-25.00	-18.93	H
5118.57	-34.94	12.76	15.86	-38.04	-25.00	-13.04	V
7678.03	-34.74	11.45	19.28	-42.57	-25.00	-17.57	V
10237.97	-32.84	12.28	23.19	-43.75	-25.00	-18.75	V



LTE Band 12 / 1.4MHz / QPSK / RB Size 1 Offset 0/ The Worst Test Results for Lowest							
Frequency(MHz)	S G.Lev (dBm)	Ant(dBi)	Loss	PMea	Limit	Margin	Polarity
				(dBm)	(dBm)	(dBm)	
1399.34	-34.86	8.17	9.34	-36.03	-13.00	-23.03	H
2098.68	-35.28	9.53	10.42	-36.17	-13.00	-23.17	H
2798.52	-32.46	11.27	11.12	-32.31	-13.00	-19.31	H
1399.34	-34.84	8.17	9.34	-36.01	-13.00	-23.01	V
2098.68	-34.60	9.53	10.42	-35.49	-13.00	-22.49	V
2798.52	-32.88	11.27	11.12	-32.73	-13.00	-19.73	V
LTE Band 12 / 1.4MHz / QPSK / RB Size 1 Offset 0/ The Worst Test Results for Middle							
Frequency(MHz)	S G.Lev (dBm)	Ant(dBi)	Loss	PMea	Limit	Margin	Polarity
				(dBm)	(dBm)	(dBm)	
1414.64	-34.17	8.17	9.34	-35.34	-13.00	-22.34	H
2122.32	-34.97	9.53	10.42	-35.86	-13.00	-22.86	H
2829.87	-33.51	11.27	11.12	-33.36	-13.00	-20.36	H
1414.64	-34.98	8.17	9.34	-36.15	-13.00	-23.15	V
2122.32	-33.86	9.53	10.42	-34.75	-13.00	-21.75	V
2829.87	-32.93	11.27	11.12	-32.78	-13.00	-19.78	V
LTE Band 12 / 1.4MHz / QPSK / RB Size 1 Offset 0/ The Worst Test Results for Highest							
Frequency(MHz)	S G.Lev (dBm)	Ant(dBi)	Loss	PMea	Limit	Margin	Polarity
				(dBm)	(dBm)	(dBm)	
1430.26	-34.54	8.17	9.34	-35.71	-13.00	-22.71	H
2145.55	-34.44	9.53	10.42	-35.33	-13.00	-22.33	H
2860.74	-32.74	11.27	11.12	-32.59	-13.00	-19.59	H
1430.26	-35.28	8.17	9.34	-36.45	-13.00	-23.45	V
2145.55	-34.00	9.53	10.42	-34.89	-13.00	-21.89	V
2860.74	-32.47	11.27	11.12	-32.32	-13.00	-19.32	V



LTE Band 12 / 3MHz / QPSK / RB Size 1 Offset 0/ The Worst Test Results for Lowest							
Frequency(MHz)	S G.Lev (dBm)	Ant(dBi)	Loss	PMea	Limit	Margin	Polarity
				(dBm)	(dBm)	(dBm)	
1400.93	-34.44	8.17	9.34	-35.61	-13.00	-22.61	H
2101.43	-34.20	9.53	10.42	-35.09	-13.00	-22.09	H
2801.84	-32.87	11.27	11.12	-32.72	-13.00	-19.72	H
1400.93	-36.01	8.17	9.34	-37.18	-13.00	-24.18	V
2101.43	-34.01	9.53	10.42	-34.90	-13.00	-21.90	V
2801.84	-32.91	11.27	11.12	-32.76	-13.00	-19.76	V
LTE Band 12 / 3MHz / QPSK / RB Size 1 Offset 0/ The Worst Test Results for Middle							
Frequency(MHz)	S G.Lev (dBm)	Ant(dBi)	Loss	PMea	Limit	Margin	Polarity
				(dBm)	(dBm)	(dBm)	
1414.53	-34.22	8.17	9.34	-35.39	-13.00	-22.39	H
2122.01	-34.51	9.53	10.42	-35.40	-13.00	-22.40	H
2829.68	-33.61	11.27	11.12	-33.46	-13.00	-20.46	H
1414.53	-35.18	8.17	9.34	-36.35	-13.00	-23.35	V
2122.01	-34.02	9.53	10.42	-34.91	-13.00	-21.91	V
2829.68	-31.78	11.27	11.12	-31.63	-13.00	-18.63	V
LTE Band 12 / 3MHz / QPSK / RB Size 1 Offset 0/ The Worst Test Results for Highest							
Frequency(MHz)	S G.Lev (dBm)	Ant(dBi)	Loss	PMea	Limit	Margin	Polarity
				(dBm)	(dBm)	(dBm)	
1428.80	-34.90	8.17	9.34	-36.07	-13.00	-23.07	H
2143.33	-34.59	9.53	10.42	-35.48	-13.00	-22.48	H
2857.81	-33.27	11.27	11.12	-33.12	-13.00	-20.12	H
1428.80	-35.08	8.17	9.34	-36.25	-13.00	-23.25	V
2143.33	-34.42	9.53	10.42	-35.31	-13.00	-22.31	V
2857.81	-33.16	11.27	11.12	-33.01	-13.00	-20.01	V





LTE Band 12 / 5MHz / QPSK / RB Size 1 Offset 0/ The Worst Test Results for Lowest							
Frequency(MHz)	S G.Lev (dBm)	Ant(dBi)	Loss	PMea	Limit	Margin	Polarity
				(dBm)	(dBm)	(dBm)	
1402.72	-33.58	8.17	9.34	-34.75	-13.00	-21.75	H
2104.45	-34.77	9.53	10.42	-35.66	-13.00	-22.66	H
2805.64	-32.54	11.27	11.12	-32.39	-13.00	-19.39	H
1402.72	-34.84	8.17	9.34	-36.01	-13.00	-23.01	V
2104.45	-34.09	9.53	10.42	-34.98	-13.00	-21.98	V
2805.64	-32.35	11.27	11.12	-32.20	-13.00	-19.20	V
LTE Band 12 / 5MHz / QPSK / RB Size 1 Offset 0/ The Worst Test Results for Middle							
Frequency(MHz)	S G.Lev (dBm)	Ant(dBi)	Loss	PMea	Limit	Margin	Polarity
				(dBm)	(dBm)	(dBm)	
1414.72	-34.36	8.17	9.34	-35.53	-13.00	-22.53	H
2122.49	-35.23	9.53	10.42	-36.12	-13.00	-23.12	H
2829.96	-32.53	11.27	11.12	-32.38	-13.00	-19.38	H
1414.72	-35.17	8.17	9.34	-36.34	-13.00	-23.34	V
2122.49	-33.93	9.53	10.42	-34.82	-13.00	-21.82	V
2829.96	-32.13	11.27	11.12	-31.98	-13.00	-18.98	V
LTE Band 12 / 5MHz / QPSK / RB Size 1 Offset 0/ The Worst Test Results for Highest							
Frequency(MHz)	S G.Lev (dBm)	Ant(dBi)	Loss	PMea	Limit	Margin	Polarity
				(dBm)	(dBm)	(dBm)	
1426.85	-33.47	8.17	9.34	-34.64	-13.00	-21.64	H
2140.28	-35.13	9.53	10.42	-36.02	-13.00	-23.02	H
2853.59	-32.67	11.27	11.12	-32.52	-13.00	-19.52	H
1426.85	-35.20	8.17	9.34	-36.37	-13.00	-23.37	V
2140.28	-34.86	9.53	10.42	-35.75	-13.00	-22.75	V
2853.59	-32.72	11.27	11.12	-32.57	-13.00	-19.57	V



LTE Band 12 / 10MHz / QPSK / RB Size 1 Offset 0/ The Worst Test Results for Lowest							
Frequency(MHz)	S G.Lev (dBm)	Ant(dBi)	Loss	PMea	Limit	Margin	Polarity
				(dBm)	(dBm)	(dBm)	
1407.68	-34.04	8.17	9.34	-35.21	-13.00	-22.21	H
2111.76	-35.34	9.53	10.42	-36.23	-13.00	-23.23	H
2815.92	-32.27	11.27	11.12	-32.12	-13.00	-19.12	H
1407.68	-34.85	8.17	9.34	-36.02	-13.00	-23.02	V
2111.76	-33.91	9.53	10.42	-34.80	-13.00	-21.80	V
2815.92	-32.83	11.27	11.12	-32.68	-13.00	-19.68	V
LTE Band 12 / 10MHz / QPSK / RB Size 1 Offset 0/ The Worst Test Results for Middle							
Frequency(MHz)	S G.Lev (dBm)	Ant(dBi)	Loss	PMea	Limit	Margin	Polarity
				(dBm)	(dBm)	(dBm)	
1414.96	-33.55	8.17	9.34	-34.72	-13.00	-21.72	H
2122.17	-34.01	9.53	10.42	-34.90	-13.00	-21.90	H
2829.89	-33.05	11.27	11.12	-32.90	-13.00	-19.90	H
1414.96	-35.80	8.17	9.34	-36.97	-13.00	-23.97	V
2122.17	-33.84	9.53	10.42	-34.73	-13.00	-21.73	V
2829.89	-32.00	11.27	11.12	-31.85	-13.00	-18.85	V
LTE Band 12 / 10MHz / QPSK / RB Size 1 Offset 0/ The Worst Test Results for Highest							
Frequency(MHz)	S G.Lev (dBm)	Ant(dBi)	Loss	PMea	Limit	Margin	Polarity
				(dBm)	(dBm)	(dBm)	
1421.82	-33.98	8.17	9.34	-35.15	-13.00	-22.15	H
2132.62	-34.68	9.53	10.42	-35.57	-13.00	-22.57	H
2843.77	-33.30	11.27	11.12	-33.15	-13.00	-20.15	H
1421.82	-35.34	8.17	9.34	-36.51	-13.00	-23.51	V
2132.62	-34.14	9.53	10.42	-35.03	-13.00	-22.03	V
2843.77	-32.74	11.27	11.12	-32.59	-13.00	-19.59	V



LTE Band 13 / 5MHz / QPSK / RB Size 1 Offset 0/ The Worst Test Results for Lowest							
Frequency(MHz)	S G.Lev (dBm)	Ant(dBi)	Loss	PMea	Limit	Margin	Polarity
				(dBm)	(dBm)	(dBm)	
1559.21	-48.09	9.56	9.72	-48.25	-40.00	-8.25	H
2338.22	-46.65	10.50	10.86	-47.01	-13.00	-34.01	H
3117.99	-45.77	12.78	11.57	-44.56	-13.00	-31.56	H
1559.21	-48.43	9.56	9.72	-48.59	-40.00	-8.59	V
2338.22	-46.80	10.50	10.86	-47.16	-13.00	-34.16	V
3117.99	-46.02	12.78	11.57	-44.81	-13.00	-31.81	V

LTE Band 13 / 5MHz / QPSK / RB Size 1 Offset 0/ The Worst Test Results for Middle							
Frequency(MHz)	S G.Lev (dBm)	Ant(dBi)	Loss	PMea	Limit	Margin	Polarity
				(dBm)	(dBm)	(dBm)	
1564.06	-48.72	9.56	9.72	-48.88	-40.00	-8.88	H
2345.67	-46.11	10.50	10.86	-46.47	-13.00	-33.47	H
3127.76	-46.57	12.78	11.57	-45.36	-13.00	-32.36	H
1564.06	-47.99	9.56	9.72	-48.15	-40.00	-8.15	V
2345.67	-46.99	10.50	10.86	-47.35	-13.00	-34.35	V
3127.76	-45.60	12.78	11.57	-44.39	-13.00	-31.39	V

LTE Band 13 / 5MHz / QPSK / RB Size 1 Offset 0/ The Worst Test Results for Highest							
Frequency(MHz)	S G.Lev (dBm)	Ant(dBi)	Loss	PMea	Limit	Margin	Polarity
				(dBm)	(dBm)	(dBm)	
1569.05	-48.86	9.56	9.72	-49.02	-40.00	-9.02	H
2353.16	-47.00	10.50	10.86	-47.36	-13.00	-34.36	H
3138.39	-45.80	12.78	11.57	-44.59	-13.00	-31.59	H
1569.05	-47.55	9.56	9.72	-47.71	-40.00	-7.71	V
2353.16	-46.65	10.50	10.86	-47.01	-13.00	-34.01	V
3138.39	-46.64	12.78	11.57	-45.43	-13.00	-32.43	V

LTE Band 13 / 10MHz / QPSK / RB Size 1 Offset 0/ The Worst Test Results for Middle							
Frequency(MHz)	S G.Lev (dBm)	Ant(dBi)	Loss	PMea	Limit	Margin	Polarity
				(dBm)	(dBm)	(dBm)	
1564.07	-48.29	9.56	9.72	-48.45	-40.00	-8.45	H
2346.17	-47.24	10.50	10.86	-47.60	-13.00	-34.60	H
3127.75	-45.67	12.78	11.57	-44.46	-13.00	-31.46	H
1564.07	-48.90	9.56	9.72	-49.06	-40.00	-9.06	V
2346.17	-46.28	10.50	10.86	-46.64	-13.00	-33.64	V
3127.75	-45.66	12.78	11.57	-44.45	-13.00	-31.45	V



LTE Band 17 / 5MHz / QPSK / RB Size 1 Offset 0/ The Worst Test Results for Lowest							
Frequency(MHz)	S G.Lev (dBm)	Ant(dBi)	Loss	PMea	Limit	Margin	Polarity
				(dBm)	(dBm)	(dBm)	
1413.18	-33.84	8.17	9.34	-35.01	-13.00	-22.01	H
2120.29	-34.04	9.53	10.42	-34.93	-13.00	-21.93	H
2826.63	-32.75	11.27	11.12	-32.60	-13.00	-19.60	H
1413.18	-35.17	8.17	9.34	-36.34	-13.00	-23.34	V
2120.29	-33.91	9.53	10.42	-34.80	-13.00	-21.80	V
2826.63	-32.31	11.27	11.12	-32.16	-13.00	-19.16	V
LTE Band 17 / 5MHz / QPSK / RB Size 1 Offset 0/ The Worst Test Results for Middle							
Frequency(MHz)	S G.Lev (dBm)	Ant(dBi)	Loss	PMea	Limit	Margin	Polarity
				(dBm)	(dBm)	(dBm)	
1420.17	-34.46	8.17	9.34	-35.63	-13.00	-22.63	H
2130.21	-34.46	9.53	10.42	-35.35	-13.00	-22.35	H
2840.17	-32.34	11.27	11.12	-32.19	-13.00	-19.19	H
1420.17	-35.28	8.17	9.34	-36.45	-13.00	-23.45	V
2130.21	-34.31	9.53	10.42	-35.20	-13.00	-22.20	V
2840.17	-32.60	11.27	11.12	-32.45	-13.00	-19.45	V
LTE Band 17 / 5MHz / QPSK / RB Size 1 Offset 0/ The Worst Test Results for Highest							
Frequency(MHz)	S G.Lev (dBm)	Ant(dBi)	Loss	PMea	Limit	Margin	Polarity
				(dBm)	(dBm)	(dBm)	
1425.95	-33.62	8.17	9.34	-34.79	-13.00	-21.79	H
2139.15	-34.95	9.53	10.42	-35.84	-13.00	-22.84	H
2852.73	-33.57	11.27	11.12	-33.42	-13.00	-20.42	H
1425.95	-34.72	8.17	9.34	-35.89	-13.00	-22.89	V
2139.15	-35.04	9.53	10.42	-35.93	-13.00	-22.93	V
2852.73	-32.30	11.27	11.12	-32.15	-13.00	-19.15	V



LTE Band 17 / 10MHz / QPSK / RB Size 1 Offset 0/ The Worst Test Results for Lowest							
Frequency(MHz)	S G.Lev (dBm)	Ant(dBi)	Loss	PMea	Limit	Margin	Polarity
				(dBm)	(dBm)	(dBm)	
1418.42	-33.74	8.17	9.34	-34.91	-13.00	-21.91	H
2127.25	-34.51	9.53	10.42	-35.40	-13.00	-22.40	H
2836.42	-33.13	11.27	11.12	-32.98	-13.00	-19.98	H
1418.42	-34.95	8.17	9.34	-36.12	-13.00	-23.12	V
2127.25	-34.33	9.53	10.42	-35.22	-13.00	-22.22	V
2836.42	-32.69	11.27	11.12	-32.54	-13.00	-19.54	V
LTE Band 17 / 10MHz / QPSK / RB Size 1 Offset 0/ The Worst Test Results for Middle							
Frequency(MHz)	S G.Lev (dBm)	Ant(dBi)	Loss	PMea	Limit	Margin	Polarity
				(dBm)	(dBm)	(dBm)	
1420.05	-34.04	8.17	9.34	-35.21	-13.00	-22.21	H
2130.23	-34.28	9.53	10.42	-35.17	-13.00	-22.17	H
2840.12	-33.58	11.27	11.12	-33.43	-13.00	-20.43	H
1420.05	-35.29	8.17	9.34	-36.46	-13.00	-23.46	V
2130.23	-33.99	9.53	10.42	-34.88	-13.00	-21.88	V
2840.12	-33.10	11.27	11.12	-32.95	-13.00	-19.95	V
LTE Band 17 / 10MHz / QPSK / RB Size 1 Offset 0/ The Worst Test Results for Highest							
Frequency(MHz)	S G.Lev (dBm)	Ant(dBi)	Loss	PMea	Limit	Margin	Polarity
				(dBm)	(dBm)	(dBm)	
1421.21	-34.12	8.17	9.34	-35.29	-13.00	-22.29	H
2131.67	-34.72	9.53	10.42	-35.61	-13.00	-22.61	H
2842.35	-33.23	11.27	11.12	-33.08	-13.00	-20.08	H
1421.21	-35.97	8.17	9.34	-37.14	-13.00	-24.14	V
2131.67	-34.46	9.53	10.42	-35.35	-13.00	-22.35	V
2842.35	-31.97	11.27	11.12	-31.82	-13.00	-18.82	V



LTE Band 26(Part 22) / 1.4MHz / QPSK / RB Size 1 Offset 0/ The Worst Test Results for Lowest							
Frequency(MHz)	S G.Lev (dBm)	Ant(dBi)	Loss	PMea	Limit	Margin	Polarity
				(dBm)	(dBm)	(dBm)	
1649.37	-34.77	9.56	9.72	-34.93	-13.00	-21.93	H
2473.66	-35.17	10.50	10.86	-35.53	-13.00	-22.53	H
3298.63	-33.52	12.78	11.57	-32.31	-13.00	-19.31	H
1649.37	-34.80	9.56	9.72	-34.96	-13.00	-21.96	V
2473.66	-34.81	10.50	10.86	-35.17	-13.00	-22.17	V
3298.63	-32.00	12.78	11.57	-30.79	-13.00	-17.79	V
LTE Band 26(Part 22) / 1.4MHz / QPSK / RB Size 1 Offset 0/ The Worst Test Results for Middle							
Frequency(MHz)	S G.Lev (dBm)	Ant(dBi)	Loss	PMea	Limit	Margin	Polarity
				(dBm)	(dBm)	(dBm)	
1673.26	-33.65	9.56	9.72	-33.81	-13.00	-20.81	H
2509.28	-34.82	10.50	10.86	-35.18	-13.00	-22.18	H
3346.22	-33.15	12.78	11.57	-31.94	-13.00	-18.94	H
1673.26	-34.95	9.56	9.72	-35.11	-13.00	-22.11	V
2509.28	-34.90	10.50	10.86	-35.26	-13.00	-22.26	V
3346.22	-31.88	12.78	11.57	-30.67	-13.00	-17.67	V
LTE Band 26(Part 22) / 1.4MHz / QPSK / RB Size 1 Offset 0/ The Worst Test Results for Highest							
Frequency(MHz)	S G.Lev (dBm)	Ant(dBi)	Loss	PMea	Limit	Margin	Polarity
				(dBm)	(dBm)	(dBm)	
1696.30	-34.83	9.56	9.72	-34.99	-13.00	-21.99	H
2544.69	-35.33	10.50	10.86	-35.69	-13.00	-22.69	H
3393.12	-32.31	12.78	11.57	-31.10	-13.00	-18.10	H
1696.30	-35.44	9.56	9.72	-35.60	-13.00	-22.60	V
2544.69	-34.35	10.50	10.86	-34.71	-13.00	-21.71	V
3393.12	-32.26	12.78	11.57	-31.05	-13.00	-18.05	V





LTE Band 26(Part 22) / 3MHz / QPSK / RB Size 1 Offset 0/ The Worst Test Results for Lowest							
Frequency(MHz)	S G.Lev (dBm)	Ant(dBi)	Loss	PMea	Limit	Margin	Polarity
				(dBm)	(dBm)	(dBm)	
1651.27	-34.62	9.56	9.72	-34.78	-13.00	-21.78	H
2476.59	-34.22	10.50	10.86	-34.58	-13.00	-21.58	H
3301.47	-32.77	12.78	11.57	-31.56	-13.00	-18.56	H
1651.27	-35.75	9.56	9.72	-35.91	-13.00	-22.91	V
2476.59	-34.23	10.50	10.86	-34.59	-13.00	-21.59	V
3301.47	-31.93	12.78	11.57	-30.72	-13.00	-17.72	V
LTE Band 26(Part 22) / 3MHz / QPSK / RB Size 1 Offset 0/ The Worst Test Results for Middle							
Frequency(MHz)	S G.Lev (dBm)	Ant(dBi)	Loss	PMea	Limit	Margin	Polarity
				(dBm)	(dBm)	(dBm)	
1673.20	-34.26	9.56	9.72	-34.42	-13.00	-21.42	H
2508.97	-34.58	10.50	10.86	-34.94	-13.00	-21.94	H
3346.08	-32.35	12.78	11.57	-31.14	-13.00	-18.14	H
1673.20	-36.01	9.56	9.72	-36.17	-13.00	-23.17	V
2508.97	-34.27	10.50	10.86	-34.63	-13.00	-21.63	V
3346.08	-32.72	12.78	11.57	-31.51	-13.00	-18.51	V
LTE Band 26(Part 22) / 3MHz / QPSK / RB Size 1 Offset 0/ The Worst Test Results for Highest							
Frequency(MHz)	S G.Lev (dBm)	Ant(dBi)	Loss	PMea	Limit	Margin	Polarity
				(dBm)	(dBm)	(dBm)	
1695.74	-34.18	9.56	9.72	-34.34	-13.00	-21.34	H
2542.41	-34.72	10.50	10.86	-35.08	-13.00	-22.08	H
3390.01	-32.31	12.78	11.57	-31.10	-13.00	-18.10	H
1695.74	-35.89	9.56	9.72	-36.05	-13.00	-23.05	V
2542.41	-34.59	10.50	10.86	-34.95	-13.00	-21.95	V
3390.01	-32.45	12.78	11.57	-31.24	-13.00	-18.24	V



LTE Band 26(Part 22) / 5MHz / QPSK / RB Size 1 Offset 0/ The Worst Test Results for Lowest							
Frequency(MHz)	S G.Lev (dBm)	Ant(dBi)	Loss	PMea	Limit	Margin	Polarity
				(dBm)	(dBm)	(dBm)	
1652.99	-34.16	9.56	9.72	-34.32	-13.00	-21.32	H
2479.26	-35.10	10.50	10.86	-35.46	-13.00	-22.46	H
3306.68	-32.39	12.78	11.57	-31.18	-13.00	-18.18	H
1652.99	-35.64	9.56	9.72	-35.80	-13.00	-22.80	V
2479.26	-34.11	10.50	10.86	-34.47	-13.00	-21.47	V
3306.68	-33.12	12.78	11.57	-31.91	-13.00	-18.91	V
LTE Band 26(Part 22) / 5MHz / QPSK / RB Size 1 Offset 0/ The Worst Test Results for Middle							
Frequency(MHz)	S G.Lev (dBm)	Ant(dBi)	Loss	PMea	Limit	Margin	Polarity
				(dBm)	(dBm)	(dBm)	
1673.14	-33.73	9.56	9.72	-33.89	-13.00	-20.89	H
2508.91	-34.61	10.50	10.86	-34.97	-13.00	-21.97	H
3345.97	-32.40	12.78	11.57	-31.19	-13.00	-18.19	H
1673.14	-35.75	9.56	9.72	-35.91	-13.00	-22.91	V
2508.91	-34.19	10.50	10.86	-34.55	-13.00	-21.55	V
3345.97	-32.73	12.78	11.57	-31.52	-13.00	-18.52	V
LTE Band 26(Part 22) / 5MHz / QPSK / RB Size 1 Offset 0/ The Worst Test Results for Highest							
Frequency(MHz)	S G.Lev (dBm)	Ant(dBi)	Loss	PMea	Limit	Margin	Polarity
				(dBm)	(dBm)	(dBm)	
1693.37	-33.53	9.56	9.72	-33.69	-13.00	-20.69	H
2539.18	-35.38	10.50	10.86	-35.74	-13.00	-22.74	H
3386.10	-33.25	12.78	11.57	-32.04	-13.00	-19.04	H
1693.37	-35.76	9.56	9.72	-35.92	-13.00	-22.92	V
2539.18	-34.97	10.50	10.86	-35.33	-13.00	-22.33	V
3386.10	-32.97	12.78	11.57	-31.76	-13.00	-18.76	V



LTE Band 26(Part 22) / 10MHz / QPSK / RB Size 1 Offset 0/ The Worst Test Results for Lowest							
Frequency(MHz)	S G.Lev (dBm)	Ant(dBi)	Loss	PMea	Limit	Margin	Polarity
				(dBm)	(dBm)	(dBm)	
1658.10	-34.26	9.56	9.72	-34.42	-13.00	-21.42	H
2486.58	-34.79	10.50	10.86	-35.15	-13.00	-22.15	H
3315.53	-32.77	12.78	11.57	-31.56	-13.00	-18.56	H
1658.10	-35.79	9.56	9.72	-35.95	-13.00	-22.95	V
2486.58	-34.37	10.50	10.86	-34.73	-13.00	-21.73	V
3315.53	-32.34	12.78	11.57	-31.13	-13.00	-18.13	V
LTE Band 26(Part 22) / 10MHz / QPSK / RB Size 1 Offset 0/ The Worst Test Results for Middle							
Frequency(MHz)	S G.Lev (dBm)	Ant(dBi)	Loss	PMea	Limit	Margin	Polarity
				(dBm)	(dBm)	(dBm)	
1672.85	-33.86	9.56	9.72	-34.02	-13.00	-21.02	H
2509.00	-34.32	10.50	10.86	-34.68	-13.00	-21.68	H
3346.20	-32.97	12.78	11.57	-31.76	-13.00	-18.76	H
1672.85	-35.21	9.56	9.72	-35.37	-13.00	-22.37	V
2509.00	-34.01	10.50	10.86	-34.37	-13.00	-21.37	V
3346.20	-33.13	12.78	11.57	-31.92	-13.00	-18.92	V
LTE Band 26(Part 22) / 10MHz / QPSK / RB Size 1 Offset 0/ The Worst Test Results for Highest							
Frequency(MHz)	S G.Lev (dBm)	Ant(dBi)	Loss	PMea	Limit	Margin	Polarity
				(dBm)	(dBm)	(dBm)	
1688.51	-33.50	9.56	9.72	-33.66	-13.00	-20.66	H
2532.04	-35.37	10.50	10.86	-35.73	-13.00	-22.73	H
3376.29	-32.74	12.78	11.57	-31.53	-13.00	-18.53	H
1688.51	-34.84	9.56	9.72	-35.00	-13.00	-22.00	V
2532.04	-34.81	10.50	10.86	-35.17	-13.00	-22.17	V
3376.29	-32.34	12.78	11.57	-31.13	-13.00	-18.13	V



LTE Band 26(Part 22) / 15MHz / QPSK / RB Size 1 Offset 0/ The Worst Test Results for Lowest							
Frequency(MHz)	S G.Lev (dBm)	Ant(dBi)	Loss	PMea	Limit	Margin	Polarity
				(dBm)	(dBm)	(dBm)	
1663.14	-34.38	9.56	9.72	-34.54	-13.00	-21.54	H
2494.44	-35.08	10.50	10.86	-35.44	-13.00	-22.44	H
3325.49	-32.46	12.78	11.57	-31.25	-13.00	-18.25	H
1663.14	-35.74	9.56	9.72	-35.90	-13.00	-22.90	V
2494.44	-34.24	10.50	10.86	-34.60	-13.00	-21.60	V
3325.49	-32.52	12.78	11.57	-31.31	-13.00	-18.31	V
LTE Band 26(Part 22) / 15MHz / QPSK / RB Size 1 Offset 0/ The Worst Test Results for Middle							
Frequency(MHz)	S G.Lev (dBm)	Ant(dBi)	Loss	PMea	Limit	Margin	Polarity
				(dBm)	(dBm)	(dBm)	
1673.19	-34.15	9.56	9.72	-34.31	-13.00	-21.31	H
2509.17	-34.81	10.50	10.86	-35.17	-13.00	-22.17	H
3346.14	-32.76	12.78	11.57	-31.55	-13.00	-18.55	H
1673.19	-35.47	9.56	9.72	-35.63	-13.00	-22.63	V
2509.17	-35.13	10.50	10.86	-35.49	-13.00	-22.49	V
3346.14	-32.51	12.78	11.57	-31.30	-13.00	-18.30	V
LTE Band 26(Part 22) / 15MHz / QPSK / RB Size 1 Offset 0/ The Worst Test Results for Highest							
Frequency(MHz)	S G.Lev (dBm)	Ant(dBi)	Loss	PMea	Limit	Margin	Polarity
				(dBm)	(dBm)	(dBm)	
1683.78	-34.50	9.56	9.72	-34.66	-13.00	-21.66	H
2524.09	-34.88	10.50	10.86	-35.24	-13.00	-22.24	H
3366.44	-32.45	12.78	11.57	-31.24	-13.00	-18.24	H
1683.78	-35.93	9.56	9.72	-36.09	-13.00	-23.09	V
2524.09	-34.50	10.50	10.86	-34.86	-13.00	-21.86	V
3366.44	-32.43	12.78	11.57	-31.22	-13.00	-18.22	V



LTE Band 26(Part 90) / 1.4MHz / QPSK / RB Size 1 Offset 0/ The Worst Test Results for Lowest							
Frequency(MHz)	S G.Lev (dBm)	Ant(dBi)	Loss	PMea	Limit	Margin	Polarity
				(dBm)	(dBm)	(dBm)	
1649.45	-33.70	9.56	9.72	-33.86	-13.00	-20.86	H
2473.65	-34.23	10.50	10.86	-34.59	-13.00	-21.59	H
3298.50	-33.31	12.78	11.57	-32.10	-13.00	-19.10	H
1649.45	-35.89	9.56	9.72	-36.05	-13.00	-23.05	V
2473.65	-34.65	10.50	10.86	-35.01	-13.00	-22.01	V
3298.50	-32.18	12.78	11.57	-30.97	-13.00	-17.97	V
LTE Band 26(Part 90) / 1.4MHz / QPSK / RB Size 1 Offset 0/ The Worst Test Results for Middle							
Frequency(MHz)	S G.Lev (dBm)	Ant(dBi)	Loss	PMea	Limit	Margin	Polarity
				(dBm)	(dBm)	(dBm)	
1673.07	-33.87	9.56	9.72	-34.03	-13.00	-21.03	H
2509.20	-34.05	10.50	10.86	-34.41	-13.00	-21.41	H
3345.98	-32.53	12.78	11.57	-31.32	-13.00	-18.32	H
1673.07	-35.65	9.56	9.72	-35.81	-13.00	-22.81	V
2509.20	-33.79	10.50	10.86	-34.15	-13.00	-21.15	V
3345.98	-33.08	12.78	11.57	-31.87	-13.00	-18.87	V
LTE Band 26(Part 90) / 1.4MHz / QPSK / RB Size 1 Offset 0/ The Worst Test Results for Highest							
Frequency(MHz)	S G.Lev (dBm)	Ant(dBi)	Loss	PMea	Limit	Margin	Polarity
				(dBm)	(dBm)	(dBm)	
1696.30	-34.68	9.56	9.72	-34.84	-13.00	-21.84	H
2544.69	-34.24	10.50	10.86	-34.60	-13.00	-21.60	H
3392.92	-32.80	12.78	11.57	-31.59	-13.00	-18.59	H
1696.30	-34.96	9.56	9.72	-35.12	-13.00	-22.12	V
2544.69	-34.74	10.50	10.86	-35.10	-13.00	-22.10	V
3392.92	-32.42	12.78	11.57	-31.21	-13.00	-18.21	V



LTE Band 26(Part 90) / 3MHz / QPSK / RB Size 1 Offset 0/ The Worst Test Results for Lowest							
Frequency(MHz)	S G.Lev (dBm)	Ant(dBi)	Loss	PMea	Limit	Margin	Polarity
				(dBm)	(dBm)	(dBm)	
1651.49	-33.65	9.56	9.72	-33.81	-13.00	-20.81	H
2476.34	-35.22	10.50	10.86	-35.58	-13.00	-22.58	H
3301.61	-33.47	12.78	11.57	-32.26	-13.00	-19.26	H
1651.49	-34.63	9.56	9.72	-34.79	-13.00	-21.79	V
2476.34	-33.99	10.50	10.86	-34.35	-13.00	-21.35	V
3301.61	-32.24	12.78	11.57	-31.03	-13.00	-18.03	V
LTE Band 26(Part 90) / 3MHz / QPSK / RB Size 1 Offset 0/ The Worst Test Results for Middle							
Frequency(MHz)	S G.Lev (dBm)	Ant(dBi)	Loss	PMea	Limit	Margin	Polarity
				(dBm)	(dBm)	(dBm)	
1673.11	-34.38	9.56	9.72	-34.54	-13.00	-21.54	H
2508.82	-35.13	10.50	10.86	-35.49	-13.00	-22.49	H
3346.23	-32.68	12.78	11.57	-31.47	-13.00	-18.47	H
1673.11	-35.20	9.56	9.72	-35.36	-13.00	-22.36	V
2508.82	-35.24	10.50	10.86	-35.60	-13.00	-22.60	V
3346.23	-31.81	12.78	11.57	-30.60	-13.00	-17.60	V
LTE Band 26(Part 90) / 3MHz / QPSK / RB Size 1 Offset 0/ The Worst Test Results for Highest							
Frequency(MHz)	S G.Lev (dBm)	Ant(dBi)	Loss	PMea	Limit	Margin	Polarity
				(dBm)	(dBm)	(dBm)	
1695.34	-34.45	9.56	9.72	-34.61	-13.00	-21.61	H
2542.07	-35.13	10.50	10.86	-35.49	-13.00	-22.49	H
3389.89	-33.64	12.78	11.57	-32.43	-13.00	-19.43	H
1695.34	-35.88	9.56	9.72	-36.04	-13.00	-23.04	V
2542.07	-34.07	10.50	10.86	-34.43	-13.00	-21.43	V
3389.89	-32.23	12.78	11.57	-31.02	-13.00	-18.02	V





LTE Band 26(Part 90) / 5MHz / QPSK / RB Size 1 Offset 0/ The Worst Test Results for Lowest							
Frequency(MHz)	S G.Lev (dBm)	Ant(dBi)	Loss	PMea	Limit	Margin	Polarity
				(dBm)	(dBm)	(dBm)	
1653.04	-33.58	9.56	9.72	-33.74	-13.00	-20.74	H
2479.43	-35.24	10.50	10.86	-35.60	-13.00	-22.60	H
3306.92	-32.29	12.78	11.57	-31.08	-13.00	-18.08	H
1653.04	-35.42	9.56	9.72	-35.58	-13.00	-22.58	V
2479.43	-34.55	10.50	10.86	-34.91	-13.00	-21.91	V
3306.92	-32.18	12.78	11.57	-30.97	-13.00	-17.97	V

LTE Band 26(Part 90) / 5MHz / QPSK / RB Size 1 Offset 0/ The Worst Test Results for Middle							
Frequency(MHz)	S G.Lev (dBm)	Ant(dBi)	Loss	PMea	Limit	Margin	Polarity
				(dBm)	(dBm)	(dBm)	
1672.93	-33.73	9.56	9.72	-33.89	-13.00	-20.89	H
2509.20	-35.06	10.50	10.86	-35.42	-13.00	-22.42	H
3346.23	-32.34	12.78	11.57	-31.13	-13.00	-18.13	H
1672.93	-35.85	9.56	9.72	-36.01	-13.00	-23.01	V
2509.20	-33.82	10.50	10.86	-34.18	-13.00	-21.18	V
3346.23	-32.51	12.78	11.57	-31.30	-13.00	-18.30	V

LTE Band 26(Part 90) / 5MHz / QPSK / RB Size 1 Offset 0/ The Worst Test Results for Highest							
Frequency(MHz)	S G.Lev (dBm)	Ant(dBi)	Loss	PMea	Limit	Margin	Polarity
				(dBm)	(dBm)	(dBm)	
1693.53	-33.78	9.56	9.72	-33.94	-13.00	-20.94	H
2539.45	-34.00	10.50	10.86	-34.36	-13.00	-21.36	H
3386.23	-32.76	12.78	11.57	-31.55	-13.00	-18.55	H
1693.53	-34.61	9.56	9.72	-34.77	-13.00	-21.77	V
2539.45	-34.31	10.50	10.86	-34.67	-13.00	-21.67	V
3386.23	-32.17	12.78	11.57	-30.96	-13.00	-17.96	V

LTE Band 26(Part 90) / 10MHz / QPSK / RB Size 1 Offset 0/ The Worst Test Results for Middle							
Frequency(MHz)	S G.Lev (dBm)	Ant(dBi)	Loss	PMea	Limit	Margin	Polarity
				(dBm)	(dBm)	(dBm)	
1663.19	-33.56	9.56	9.72	-33.72	-13.00	-20.72	H
2494.19	-34.18	10.50	10.86	-34.54	-13.00	-21.54	H
3325.48	-32.50	12.78	11.57	-31.29	-13.00	-18.29	H
1663.19	-35.69	9.56	9.72	-35.85	-13.00	-22.85	V
2494.19	-35.19	10.50	10.86	-35.55	-13.00	-22.55	V
3325.48	-32.27	12.78	11.57	-31.06	-13.00	-18.06	V



LTE Band 41 / 5MHz / QPSK / RB Size 1 Offset 0/ The Worst Test Results for Lowest							
Frequency(MHz)	S G.Lev (dBm)	Ant(dBi)	Loss	PMea	Limit	Margin	Polarity
				(dBm)	(dBm)	(dBm)	
5115.16	-34.31	12.66	15.86	-37.51	-25.00	-12.51	H
7672.65	-34.51	11.46	19.28	-42.33	-25.00	-17.33	H
10230.08	-33.37	12.79	23.19	-43.77	-25.00	-18.77	H
5115.16	-35.77	12.66	15.86	-38.97	-25.00	-13.97	V
7672.65	-34.05	11.46	19.28	-41.87	-25.00	-16.87	V
10230.08	-32.64	12.79	23.19	-43.04	-25.00	-18.04	V
LTE Band 41 / 5MHz / QPSK / RB Size 1 Offset 0/ The Worst Test Results for Middle							
Frequency(MHz)	S G.Lev (dBm)	Ant(dBi)	Loss	PMea	Limit	Margin	Polarity
				(dBm)	(dBm)	(dBm)	
5210.14	-34.66	12.72	15.86	-37.80	-25.00	-12.80	H
7815.31	-34.60	11.46	19.28	-42.42	-25.00	-17.42	H
10420.31	-32.65	12.09	23.19	-43.75	-25.00	-18.75	H
5210.14	-35.11	12.72	15.86	-38.25	-25.00	-13.25	V
7815.31	-34.39	11.46	19.28	-42.21	-25.00	-17.21	V
10420.31	-32.28	12.09	23.19	-43.38	-25.00	-18.38	V
LTE Band 41 / 5MHz / QPSK / RB Size 1 Offset 0/ The Worst Test Results for Highest							
Frequency(MHz)	S G.Lev (dBm)	Ant(dBi)	Loss	PMea	Limit	Margin	Polarity
				(dBm)	(dBm)	(dBm)	
5304.99	-34.70	12.76	15.86	-37.80	-25.00	-12.80	H
7957.57	-35.14	11.45	19.28	-42.97	-25.00	-17.97	H
10610.24	-32.52	12.28	23.19	-43.43	-25.00	-18.43	H
5304.99	-35.39	12.76	15.86	-38.49	-25.00	-13.49	V
7957.57	-33.94	11.45	19.28	-41.77	-25.00	-16.77	V
10610.24	-32.12	12.28	23.19	-43.03	-25.00	-18.03	V



LTE Band 41 / 10MHz / QPSK / RB Size 1 Offset 0/ The Worst Test Results for Lowest							
Frequency(MHz)	S G.Lev (dBm)	Ant(dBi)	Loss	PMea	Limit	Margin	Polarity
				(dBm)	(dBm)	(dBm)	
5119.95	-34.74	12.66	15.86	-37.94	-25.00	-12.94	H
7679.96	-34.49	11.46	19.28	-42.31	-25.00	-17.31	H
10240.32	-33.64	12.79	23.19	-44.04	-25.00	-19.04	H
5119.95	-35.20	12.66	15.86	-38.40	-25.00	-13.40	V
7679.96	-34.61	11.46	19.28	-42.43	-25.00	-17.43	V
10240.32	-32.35	12.79	23.19	-42.75	-25.00	-17.75	V
LTE Band 41 / 10MHz / QPSK / RB Size 1 Offset 0/ The Worst Test Results for Middle							
Frequency(MHz)	S G.Lev (dBm)	Ant(dBi)	Loss	PMea	Limit	Margin	Polarity
				(dBm)	(dBm)	(dBm)	
5209.78	-34.44	12.72	15.86	-37.58	-25.00	-12.58	H
7815.10	-35.32	11.46	19.28	-43.14	-25.00	-18.14	H
10420.28	-32.48	12.09	23.19	-43.58	-25.00	-18.58	H
5209.78	-35.96	12.72	15.86	-39.10	-25.00	-14.10	V
7815.10	-34.25	11.46	19.28	-42.07	-25.00	-17.07	V
10420.28	-32.08	12.09	23.19	-43.18	-25.00	-18.18	V
LTE Band 41 / 10MHz / QPSK / RB Size 1 Offset 0/ The Worst Test Results for Highest							
Frequency(MHz)	S G.Lev (dBm)	Ant(dBi)	Loss	PMea	Limit	Margin	Polarity
				(dBm)	(dBm)	(dBm)	
5300.18	-34.15	12.76	15.86	-37.25	-25.00	-12.25	H
7950.16	-34.35	11.45	19.28	-42.18	-25.00	-17.18	H
10599.89	-32.73	12.28	23.19	-43.64	-25.00	-18.64	H
5300.18	-34.52	12.76	15.86	-37.62	-25.00	-12.62	V
7950.16	-34.77	11.45	19.28	-42.60	-25.00	-17.60	V
10599.89	-32.74	12.28	23.19	-43.65	-25.00	-18.65	V



LTE Band 41 / 15MHz / QPSK / RB Size 1 Offset 0/ The Worst Test Results for Lowest							
Frequency(MHz)	S G.Lev (dBm)	Ant(dBi)	Loss	PMea	Limit	Margin	Polarity
				(dBm)	(dBm)	(dBm)	
5125.27	-34.91	12.66	15.86	-38.11	-25.00	-13.11	H
7687.72	-35.21	11.46	19.28	-43.03	-25.00	-18.03	H
10250.37	-33.00	12.79	23.19	-43.40	-25.00	-18.40	H
5125.27	-34.66	12.66	15.86	-37.86	-25.00	-12.86	V
7687.72	-33.88	11.46	19.28	-41.70	-25.00	-16.70	V
10250.37	-32.18	12.79	23.19	-42.58	-25.00	-17.58	V
LTE Band 41 / 15MHz / QPSK / RB Size 1 Offset 0/ The Worst Test Results for Middle							
Frequency(MHz)	S G.Lev (dBm)	Ant(dBi)	Loss	PMea	Limit	Margin	Polarity
				(dBm)	(dBm)	(dBm)	
5209.88	-34.38	12.72	15.86	-37.52	-25.00	-12.52	H
7814.88	-34.65	11.46	19.28	-42.47	-25.00	-17.47	H
10420.05	-33.58	12.09	23.19	-44.68	-25.00	-19.68	H
5209.88	-35.34	12.72	15.86	-38.48	-25.00	-13.48	V
7814.88	-34.32	11.46	19.28	-42.14	-25.00	-17.14	V
10420.05	-32.60	12.09	23.19	-43.70	-25.00	-18.70	V
LTE Band 41 / 15MHz / QPSK / RB Size 1 Offset 0/ The Worst Test Results for Highest							
Frequency(MHz)	S G.Lev (dBm)	Ant(dBi)	Loss	PMea	Limit	Margin	Polarity
				(dBm)	(dBm)	(dBm)	
5297.96	-34.58	12.76	15.86	-37.68	-25.00	-12.68	H
7942.64	-35.39	11.45	19.28	-43.22	-25.00	-18.22	H
10589.96	-33.48	12.28	23.19	-44.39	-25.00	-19.39	H
5297.96	-34.64	12.76	15.86	-37.74	-25.00	-12.74	V
7942.64	-33.91	11.45	19.28	-41.74	-25.00	-16.74	V
10589.96	-32.12	12.28	23.19	-43.03	-25.00	-18.03	V



LTE Band 41 / 20MHz / QPSK / RB Size 1 Offset 0/ The Worst Test Results for Lowest							
Frequency(MHz)	S G.Lev (dBm)	Ant(dBi)	Loss	PMea	Limit	Margin	Polarity
				(dBm)	(dBm)	(dBm)	
5130.03	-34.20	12.66	15.86	-37.40	-25.00	-12.40	H
7694.86	-34.80	11.46	19.28	-42.62	-25.00	-17.62	H
10260.11	-33.49	12.79	23.19	-43.89	-25.00	-18.89	H
5130.03	-35.04	12.66	15.86	-38.24	-25.00	-13.24	V
7694.86	-34.47	11.46	19.28	-42.29	-25.00	-17.29	V
10260.11	-32.62	12.79	23.19	-43.02	-25.00	-18.02	V
LTE Band 41 / 20MHz / QPSK / RB Size 1 Offset 0/ The Worst Test Results for Middle							
Frequency(MHz)	S G.Lev (dBm)	Ant(dBi)	Loss	PMea	Limit	Margin	Polarity
				(dBm)	(dBm)	(dBm)	
5210.20	-34.82	12.72	15.86	-37.96	-25.00	-12.96	H
7815.12	-34.42	11.46	19.28	-42.24	-25.00	-17.24	H
10419.99	-32.75	12.09	23.19	-43.85	-25.00	-18.85	H
5210.20	-35.60	12.72	15.86	-38.74	-25.00	-13.74	V
7815.12	-33.92	11.46	19.28	-41.74	-25.00	-16.74	V
10419.99	-31.76	12.09	23.19	-42.86	-25.00	-17.86	V
LTE Band 41 / 20MHz / QPSK / RB Size 1 Offset 0/ The Worst Test Results for Highest							
Frequency(MHz)	S G.Lev (dBm)	Ant(dBi)	Loss	PMea	Limit	Margin	Polarity
				(dBm)	(dBm)	(dBm)	
5289.93	-34.09	12.76	15.86	-37.19	-25.00	-12.19	H
7934.98	-34.35	11.45	19.28	-42.18	-25.00	-17.18	H
10580.09	-33.06	12.28	23.19	-43.97	-25.00	-18.97	H
5289.93	-35.48	12.76	15.86	-38.58	-25.00	-13.58	V
7934.98	-34.76	11.45	19.28	-42.59	-25.00	-17.59	V
10580.09	-31.89	12.28	23.19	-42.80	-25.00	-17.80	V



LTE Band 66 / 1.4MHz / QPSK / RB Size 1 Offset 0/ The Worst Test Results for Lowest							
Frequency(MHz)	S G.Lev (dBm)	Ant(dBi)	Loss	PMea	Limit	Margin	Polarity
				(dBm)	(dBm)	(dBm)	
3421.47	-34.32	12.90	12.56	-33.98	-13.00	-20.98	H
5131.90	-34.57	13.10	16.32	-37.79	-13.00	-24.79	H
6842.46	-32.55	12.33	21.13	-41.35	-13.00	-28.35	H
3421.47	-35.34	12.90	12.56	-35.00	-13.00	-22.00	V
5131.90	-34.47	13.10	16.32	-37.69	-13.00	-24.69	V
6842.46	-33.09	12.33	21.13	-41.89	-13.00	-28.89	V
LTE Band 66 / 1.4MHz / QPSK / RB Size 1 Offset 0/ The Worst Test Results for Middle							
Frequency(MHz)	S G.Lev (dBm)	Ant(dBi)	Loss	PMea	Limit	Margin	Polarity
				(dBm)	(dBm)	(dBm)	
3490.14	-34.77	12.90	12.56	-34.43	-13.00	-21.43	H
5235.29	-34.74	13.10	16.32	-37.96	-13.00	-24.96	H
6979.83	-32.91	12.33	21.13	-41.71	-13.00	-28.71	H
3490.14	-35.00	12.90	12.56	-34.66	-13.00	-21.66	V
5235.29	-35.22	13.10	16.32	-38.44	-13.00	-25.44	V
6979.83	-32.49	12.33	21.13	-41.29	-13.00	-28.29	V
LTE Band 66 / 1.4MHz / QPSK / RB Size 1 Offset 0/ The Worst Test Results for Highest							
Frequency(MHz)	S G.Lev (dBm)	Ant(dBi)	Loss	PMea	Limit	Margin	Polarity
				(dBm)	(dBm)	(dBm)	
3557.87	-33.91	12.90	12.56	-33.57	-13.00	-20.57	H
5337.01	-35.47	13.10	16.32	-38.69	-13.00	-25.69	H
7117.18	-32.35	12.33	21.13	-41.15	-13.00	-28.15	H
3557.87	-34.99	12.90	12.56	-34.65	-13.00	-21.65	V
5337.01	-34.35	13.10	16.32	-37.57	-13.00	-24.57	V
7117.18	-32.86	12.33	21.13	-41.66	-13.00	-28.66	V





LTE Band 66 / 3MHz / QPSK / RB Size 1 Offset 0/ The Worst Test Results for Lowest							
Frequency(MHz)	S G.Lev (dBm)	Ant(dBi)	Loss	PMea	Limit	Margin	Polarity
				(dBm)	(dBm)	(dBm)	
3422.91	-34.27	12.90	12.56	-33.93	-13.00	-20.93	H
5134.34	-35.23	13.10	16.32	-38.45	-13.00	-25.45	H
6846.03	-32.85	12.33	21.13	-41.65	-13.00	-28.65	H
3422.91	-35.72	12.90	12.56	-35.38	-13.00	-22.38	V
5134.34	-34.75	13.10	16.32	-37.97	-13.00	-24.97	V
6846.03	-31.93	12.33	21.13	-40.73	-13.00	-27.73	V
LTE Band 66 / 3MHz / QPSK / RB Size 1 Offset 0/ The Worst Test Results for Middle							
Frequency(MHz)	S G.Lev (dBm)	Ant(dBi)	Loss	PMea	Limit	Margin	Polarity
				(dBm)	(dBm)	(dBm)	
3490.17	-34.43	12.90	12.56	-34.09	-13.00	-21.09	H
5235.09	-34.66	13.10	16.32	-37.88	-13.00	-24.88	H
6980.22	-33.46	12.33	21.13	-42.26	-13.00	-29.26	H
3490.17	-34.61	12.90	12.56	-34.27	-13.00	-21.27	V
5235.09	-34.81	13.10	16.32	-38.03	-13.00	-25.03	V
6980.22	-32.05	12.33	21.13	-40.85	-13.00	-27.85	V
LTE Band 66 / 3MHz / QPSK / RB Size 1 Offset 0/ The Worst Test Results for Highest							
Frequency(MHz)	S G.Lev (dBm)	Ant(dBi)	Loss	PMea	Limit	Margin	Polarity
				(dBm)	(dBm)	(dBm)	
3556.97	-33.86	12.90	12.56	-33.52	-13.00	-20.52	H
5262.46	-34.23	13.10	16.32	-37.45	-13.00	-24.45	H
7113.93	-32.23	12.33	21.13	-41.03	-13.00	-28.03	H
3556.97	-35.62	12.90	12.56	-35.28	-13.00	-22.28	V
5262.46	-34.75	13.10	16.32	-37.97	-13.00	-24.97	V
7113.93	-31.72	12.33	21.13	-40.52	-13.00	-27.52	V



LTE Band 66 / 5MHz / QPSK / RB Size 1 Offset 0/ The Worst Test Results for Lowest							
Frequency(MHz)	S G.Lev (dBm)	Ant(dBi)	Loss	PMea	Limit	Margin	Polarity
				(dBm)	(dBm)	(dBm)	
3425.39	-34.83	12.90	12.56	-34.49	-13.00	-21.49	H
5137.38	-34.44	13.10	16.32	-37.66	-13.00	-24.66	H
6850.25	-32.70	12.33	21.13	-41.50	-13.00	-28.50	H
3425.39	-35.14	12.90	12.56	-34.80	-13.00	-21.80	V
5137.38	-34.33	13.10	16.32	-37.55	-13.00	-24.55	V
6850.25	-32.89	12.33	21.13	-41.69	-13.00	-28.69	V
LTE Band 66 / 5MHz / QPSK / RB Size 1 Offset 0/ The Worst Test Results for Middle							
Frequency(MHz)	S G.Lev (dBm)	Ant(dBi)	Loss	PMea	Limit	Margin	Polarity
				(dBm)	(dBm)	(dBm)	
3490.25	-34.55	12.90	12.56	-34.21	-13.00	-21.21	H
5235.29	-34.99	13.10	16.32	-38.21	-13.00	-25.21	H
6980.13	-33.64	12.33	21.13	-42.44	-13.00	-29.44	H
3490.25	-34.53	12.90	12.56	-34.19	-13.00	-21.19	V
5235.29	-34.48	13.10	16.32	-37.70	-13.00	-24.70	V
6980.13	-32.65	12.33	21.13	-41.45	-13.00	-28.45	V
LTE Band 66 / 5MHz / QPSK / RB Size 1 Offset 0/ The Worst Test Results for Highest							
Frequency(MHz)	S G.Lev (dBm)	Ant(dBi)	Loss	PMea	Limit	Margin	Polarity
				(dBm)	(dBm)	(dBm)	
3557.95	-34.43	12.90	12.56	-34.09	-13.00	-21.09	H
5234.86	-35.37	13.10	16.32	-38.59	-13.00	-25.59	H
7110.13	-32.28	12.33	21.13	-41.08	-13.00	-28.08	H
3557.95	-34.85	12.90	12.56	-34.51	-13.00	-21.51	V
5234.86	-35.22	13.10	16.32	-38.44	-13.00	-25.44	V
7110.13	-32.94	12.33	21.13	-41.74	-13.00	-28.74	V



LTE Band 66 / 10MHz / QPSK / RB Size 1 Offset 0/ The Worst Test Results for Lowest							
Frequency(MHz)	S G.Lev (dBm)	Ant(dBi)	Loss	PMea	Limit	Margin	Polarity
				(dBm)	(dBm)	(dBm)	
3429.87	-34.65	12.90	12.56	-34.31	-13.00	-21.31	H
5145.16	-34.00	13.10	16.32	-37.22	-13.00	-24.22	H
6880.18	-33.55	12.33	21.13	-42.35	-13.00	-29.35	H
3429.87	-35.86	12.90	12.56	-35.52	-13.00	-22.52	V
5145.16	-34.04	13.10	16.32	-37.26	-13.00	-24.26	V
6880.18	-31.76	12.33	21.13	-40.56	-13.00	-27.56	V
LTE Band 66 / 10MHz / QPSK / RB Size 1 Offset 0/ The Worst Test Results for Middle							
Frequency(MHz)	S G.Lev (dBm)	Ant(dBi)	Loss	PMea	Limit	Margin	Polarity
				(dBm)	(dBm)	(dBm)	
3489.89	-33.97	12.90	12.56	-33.63	-13.00	-20.63	H
5235.10	-35.27	13.10	16.32	-38.49	-13.00	-25.49	H
6979.97	-33.55	12.33	21.13	-42.35	-13.00	-29.35	H
3489.89	-36.01	12.90	12.56	-35.67	-13.00	-22.67	V
5235.10	-35.20	13.10	16.32	-38.42	-13.00	-25.42	V
6979.97	-32.64	12.33	21.13	-41.44	-13.00	-28.44	V
LTE Band 66 / 10MHz / QPSK / RB Size 1 Offset 0/ The Worst Test Results for Highest							
Frequency(MHz)	S G.Lev (dBm)	Ant(dBi)	Loss	PMea	Limit	Margin	Polarity
				(dBm)	(dBm)	(dBm)	
3550.72	-34.88	12.90	12.56	-34.54	-13.00	-21.54	H
5235.15	-34.14	13.10	16.32	-37.36	-13.00	-24.36	H
7099.91	-32.78	12.33	21.13	-41.58	-13.00	-28.58	H
3550.72	-35.57	12.90	12.56	-35.23	-13.00	-22.23	V
5235.15	-34.02	13.10	16.32	-37.24	-13.00	-24.24	V
7099.91	-32.12	12.33	21.13	-40.92	-13.00	-27.92	V



LTE Band 66 / 15MHz / QPSK / RB Size 1 Offset 0/ The Worst Test Results for Lowest							
Frequency(MHz)	S G.Lev (dBm)	Ant(dBi)	Loss	PMea	Limit	Margin	Polarity
				(dBm)	(dBm)	(dBm)	
3435.19	-34.73	12.90	12.56	-34.39	-13.00	-21.39	H
5152.23	-35.02	13.10	16.32	-38.24	-13.00	-25.24	H
6870.08	-32.44	12.33	21.13	-41.24	-13.00	-28.24	H
3435.19	-35.84	12.90	12.56	-35.50	-13.00	-22.50	V
5152.23	-34.67	13.10	16.32	-37.89	-13.00	-24.89	V
6870.08	-33.17	12.33	21.13	-41.97	-13.00	-28.97	V
LTE Band 66 / 15MHz / QPSK / RB Size 1 Offset 0/ The Worst Test Results for Middle							
Frequency(MHz)	S G.Lev (dBm)	Ant(dBi)	Loss	PMea	Limit	Margin	Polarity
				(dBm)	(dBm)	(dBm)	
3490.21	-33.98	12.90	12.56	-33.64	-13.00	-20.64	H
5234.87	-34.24	13.10	16.32	-37.46	-13.00	-24.46	H
6980.16	-33.38	12.33	21.13	-42.18	-13.00	-29.18	H
3490.21	-35.05	12.90	12.56	-34.71	-13.00	-21.71	V
5234.87	-35.00	13.10	16.32	-38.22	-13.00	-25.22	V
6980.16	-33.06	12.33	21.13	-41.86	-13.00	-28.86	V
LTE Band 66 / 15MHz / QPSK / RB Size 1 Offset 0/ The Worst Test Results for Highest							
Frequency(MHz)	S G.Lev (dBm)	Ant(dBi)	Loss	PMea	Limit	Margin	Polarity
				(dBm)	(dBm)	(dBm)	
3544.88	-34.67	12.90	12.56	-34.33	-13.00	-21.33	H
5332.34	-34.87	13.10	16.32	-38.09	-13.00	-25.09	H
7090.19	-32.70	12.33	21.13	-41.50	-13.00	-28.50	H
3544.88	-35.46	12.90	12.56	-35.12	-13.00	-22.12	V
5332.34	-35.05	13.10	16.32	-38.27	-13.00	-25.27	V
7090.19	-32.58	12.33	21.13	-41.38	-13.00	-28.38	V



LTE Band 66 / 20MHz / QPSK / RB Size 1 Offset 0/ The Worst Test Results for Lowest							
Frequency(MHz)	S G.Lev (dBm)	Ant(dBi)	Loss	PMea	Limit	Margin	Polarity
				(dBm)	(dBm)	(dBm)	
3439.91	-34.81	12.90	12.56	-34.47	-13.00	-21.47	H
5159.82	-34.06	13.10	16.32	-37.28	-13.00	-24.28	H
6880.17	-33.33	12.33	21.13	-42.13	-13.00	-29.13	H
3439.91	-35.64	12.90	12.56	-35.30	-13.00	-22.30	V
5159.82	-34.78	13.10	16.32	-38.00	-13.00	-25.00	V
6880.17	-32.63	12.33	21.13	-41.43	-13.00	-28.43	V
LTE Band 66 / 20MHz / QPSK / RB Size 1 Offset 0/ The Worst Test Results for Middle							
Frequency(MHz)	S G.Lev (dBm)	Ant(dBi)	Loss	PMea	Limit	Margin	Polarity
				(dBm)	(dBm)	(dBm)	
3490.27	-33.51	12.90	12.56	-33.17	-13.00	-20.17	H
5234.82	-34.94	13.10	16.32	-38.16	-13.00	-25.16	H
6979.98	-33.14	12.33	21.13	-41.94	-13.00	-28.94	H
3490.27	-35.48	12.90	12.56	-35.14	-13.00	-22.14	V
5234.82	-33.93	13.10	16.32	-37.15	-13.00	-24.15	V
6979.98	-33.13	12.33	21.13	-41.93	-13.00	-28.93	V
LTE Band 66 / 20MHz / QPSK / RB Size 1 Offset 0/ The Worst Test Results for Highest							
Frequency(MHz)	S G.Lev (dBm)	Ant(dBi)	Loss	PMea	Limit	Margin	Polarity
				(dBm)	(dBm)	(dBm)	
3539.83	-33.71	12.90	12.56	-33.37	-13.00	-20.37	H
5309.78	-34.97	13.10	16.32	-38.19	-13.00	-25.19	H
7080.72	-33.61	12.33	21.13	-42.41	-13.00	-29.41	H
3539.83	-35.57	12.90	12.56	-35.23	-13.00	-22.23	V
5309.78	-34.05	13.10	16.32	-37.27	-13.00	-24.27	V
7080.72	-33.01	12.33	21.13	-41.81	-13.00	-28.81	V



#### APPENDIX-PHOTOS OF TEST SETUP

Note: See test photos in setup photo document for the actual connections between Product and support equipment.

\*\*\*\*\*END OF THE REPORT\*\*\*\*\*

