



**Shenzhen Global Test Service Co.,Ltd.**

No.7-101 and 8A-104, Building 7 and 8, DCC Cultural and Creative Garden, No.98, Pingxin North Road, Shangmugu Community, Pinghu Street, Longgang District, Shenzhen, Guangdong

## FCC PART 15 SUBPART C TEST REPORT

### FCC PART 15.247

**Report Reference No.....:** GTS20230704026-1-38

**FCC ID..... :** 2AYD5-I23D02

Compiled by  
( position+printed name+signature)..: File administrators Peter Xiao

Supervised by  
( position+printed name+signature)..: Test Engineer Evan Ouyang

Approved by  
( position+printed name+signature)..: Manager Jason Hu

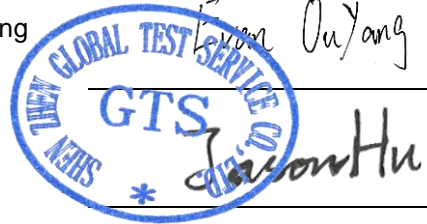

Date of issue.....: Sep.06, 2023

**Representative Laboratory Name.:** Shenzhen Global Test Service Co.,Ltd.

Address .....: No.7-101 and 8A-104, Building 7 and 8, DCC Cultural and Creative Garden, No.98, Pingxin North Road, Shangmugu Community, Pinghu Street, Longgang District, Shenzhen, Guangdong,China

**Applicant's name.....:** Imin Technology Pte Ltd

Address .....: 11 Bishan Street 21, #03-05 Bosch Building, Singapore 573943

**Test specification .....**

Standard .....: **FCC Part 15.247: Operation within the bands 902-928 MHz, 2400-2483.5 MHz and 5725-5850 MHz**

TRF Originator.....: Shenzhen Global Test Service Co.,Ltd.

Master TRF.....: Dated 2014-12

**Shenzhen Global Test Service Co.,Ltd. All rights reserved.**

This publication may be reproduced in whole or in part for non-commercial purposes as long as the Shenzhen Global Test Service Co.,Ltd. is acknowledged as copyright owner and source of the material. Shenzhen Global Test Service Co.,Ltd. takes no responsibility for and will not assume liability for damages resulting from the reader's interpretation of the reproduced material due to its placement and context.

**Test item description .....** POS Device

Trade Mark .....:

Manufacturer .....: Imin Technology Pte Ltd

Model/Type reference .....: I23D02

List Models .....: N/A

Modulation Type.....: GFSK,π/4-DQPSK,8DPSK

Operation Frequency.....: From 2402MHz to 2480MHz

Hardware Version .....: N/A

Software Version .....: N/A

Rating .....: DC 24V/1.5A by adapter

Result .....: **PASS**

# TEST REPORT

<b>Test Report No. :</b>	<b>GTS20230704026-1-38</b>	Sep.06, 2023
		Date of issue

Equipment under Test : POS Device

Model /Type : I23D02

Listed model : N/A

**Applicant** : **Imin Technology Pte Ltd**

Address : 11 Bishan Street 21, #03-05 Bosch Building, Singapore 573943

**Manufacturer** : **Imin Technology Pte Ltd**

Address : 11 Bishan Street 21, #03-05 Bosch Building, Singapore 573943

<b>Test Result:</b>	<b>PASS</b>
---------------------	-------------

The test report merely corresponds to the test sample.  
It is not permitted to copy extracts of these test result without the written permission of the test laboratory.

## Contents

<b>1. TEST STANDARDS .....</b>	<b>4</b>
<b>2. SUMMARY .....</b>	<b>5</b>
2.1. General Remarks .....	5
2.2. Product Description .....	5
2.3. Equipment Under Test .....	7
2.4. Short description of the Equipment under Test (EUT) .....	7
2.5. EUT operation mode .....	7
2.6. Block Diagram of Test Setup .....	8
2.7. Related Submittal(s) / Grant (s) .....	8
2.8. EUT Exercise Software .....	8
2.9. Special Accessories .....	8
2.10. External I/O Cable .....	8
2.11. Modifications .....	8
<b>3. TEST ENVIRONMENT .....</b>	<b>9</b>
3.1. Address of the test laboratory .....	9
3.2. Test Facility .....	9
3.3. Environmental conditions .....	9
3.4. Statement of the measurement uncertainty .....	9
3.5. Summary of measurement results .....	10
3.6. Equipments Used during the Test.....	11
<b>4. TEST CONDITIONS AND RESULTS .....</b>	<b>12</b>
4.1. AC Power Conducted Emission .....	12
4.2. Radiated Emission .....	19
4.3. Maximum Peak Output Power .....	29
4.4. 99% and 20dB Bandwidth .....	30
4.5. Frequency Separation .....	31
4.6. Conducted Spurious Emissions and Band Edge Compliance of RF Emission.....	32
4.7. Number of hopping frequency .....	34
4.8. Time Of Occupancy(Dwell Time) .....	35
4.9. Pseudorandom Frequency Hopping Sequence .....	36
4.10. Antenna Requirement .....	37
<b>5. TEST SETUP PHOTOS OF THE EUT.....</b>	<b>38</b>
<b>6. EXTERNAL AND INTERNAL PHOTOS OF THE EUT .....</b>	<b>40</b>
6.1. External photos of the EUT .....	40
6.2. Internal photos of the EUT .....	40

## 1. TEST STANDARDS

The tests were performed according to following standards:

[FCC Rules Part 15.247](#): Frequency Hopping, Direct Spread Spectrum and Hybrid Systems that are in operation within the bands of 902-928 MHz, 2400-2483.5 MHz, and 5725-5850 MHz.

[ANSI C63.10-2020](#): American National Standard for Testing Unlicensed Wireless Devices

[KDB 558074 D01 15.247 Meas Guidance v05r02](#): Digital Transmission Systems (DTS) and Frequency Hopping measurement procedures

## 2. SUMMARY

### 2.1. General Remarks

Date of receipt of test sample	:	Aug.18, 2023
Testing commenced on	:	Aug.18, 2023
Testing concluded on	:	Sep.05, 2023

### 2.2. Product Description

Product Name:	POS Device
Trade Mark:	
Model/Type reference:	I23D02
List Model:	N/A
Model Declaration	N/A
Power supply:	DC 24V/1.5A by adapter
Hardware Version	N/A
Software Version	N/A
Sample ID	GTS20230704026-1-S0001-3# GTS20230704026-1-S0001-4#( Version A ) GTS20230704026-1-S0001-5#( Version B )
Bluetooth	
Frequency Range	2402MHz ~ 2480MHz
Channel Number	79 channels for Bluetooth (DSS) 40 channels for Bluetooth (DTS)
Channel Spacing	1MHz for Bluetooth (DSS) 2MHz for Bluetooth (DTS)
Modulation Type	GFSK, $\pi/4$ -DQPSK, 8DPSK for Bluetooth (DSS) GFSK for Bluetooth (DTS)
2.4GWLAN	
WLAN Operation frequency	IEEE 802.11b:2412-2462MHz IEEE 802.11g:2412-2462MHz IEEE 802.11n HT20:2412-2462MHz IEEE 802.11ax HE20:2412-2462MHz
WLAN Modulation Type	IEEE 802.11b: DSSS(CCK,DQPSK,DBPSK) IEEE 802.11g: OFDM(64QAM, 16QAM, QPSK, BPSK) IEEE 802.11n HT20: OFDM (64QAM, 16QAM, QPSK,BPSK) IEEE 802.11ax HE20: OFDMA (1024QAM,256QAM,64QAM,16QAM, QPSK,BPSK)
Channel number:	11 Channel for IEEE 802.11b/g/n/ax (HT20)
Channel separation:	5MHz
WIFI(5.2G/5.3G/5.7G/5.8G Band)	
WLAN Operation frequency	5180-5240MHz/ 5260MHz to 5320MHz/ 5500MHz to 5700MHz/ 5745MHz to 5825MHz
WLAN Modulation Type	IEEE 802.11a: OFDM(64QAM, 16QAM, QPSK, BPSK) IEEE 802.11n HT20: OFDM (64QAM, 16QAM, QPSK,BPSK) IEEE 802.11ac VHT20: OFDM (256QAM,64QAM, 16QAM, QPSK,BPSK) IEEE 802.11ax HE20: OFDMA (1024QAM,256QAM,64QAM, 16QAM, QPSK,BPSK)

	<p>IEEE 802.11n HT40: OFDM (64QAM, 16QAM, QPSK,BPSK)                  IEEE 802.11ac VHT40: OFDM (256QAM,64QAM, 16QAM, QPSK,BPSK)                  IEEE 802.11ax HE40: OFDMA (1024QAM,256QAM,64QAM, 16QAM, QPSK,BPSK)                  IEEE 802.11ac VHT80: OFDM (256QAM,64QAM, 16QAM, QPSK,BPSK)                  IEEE 802.11ax HE80: OFDMA (1024QAM,256QAM,64QAM, 16QAM, QPSK,BPSK)</p>
Channel number:	<p>4 Channels for 20MHz bandwidth(5180-5240MHz)                  4 Channels for 20MHz bandwidth(5260-5320MHz)                  11 Channels for 20MHz bandwidth(5500-5700MHz)                  5 channels for 20MHz bandwidth(5745-5825MHz)                  2 channels for 40MHz bandwidth(5190~5230MHz)                  2 channels for 40MHz bandwidth(5270~5310MHz)                  5 Channels for 40MHz bandwidth(5510-5670MHz)                  2 channels for 40MHz bandwidth(5755~5795MHz)                  1 channels for 80MHz bandwidth(5210MHz)                  1 channels for 80MHz bandwidth(5290MHz)                  2 Channels for 80MHz bandwidth(5530-5610MHz)                  1 channels for 80MHz bandwidth(5775MHz)</p>
Antenna Description	<p>Three Internal antenna respectively.WLAN support 2*2MIMO technology.                  ANT0 used for WIFI TX/RX, 3.13 dBi(Max.) for 2.4G Band and 1.76dBi(Max.) for 5G Band                  ANT1 used for WIFI TX/RX, 3.13 dBi(Max.) for 2.4G Band and 1.76dBi (Max.) for 5G Band                  ANT2 used for BT TX/RX, 3.66 dBi(Max.) for 2.4G Band</p>
RFID(13.56MHz) (Optional)	
Frequency Range	13.56MHz
Channel Number	1
Modulation Type	ASK
Antenna Description	Internal Antenna, 0dBi (Max.)
<p>Remark:The I23D02 model has 2 versions;                  Version A: One large display and one small display                  Version B: Only one large display</p>	

### 2.3. Equipment Under Test

#### Power supply system utilised

Power supply voltage	:	<input type="radio"/> 230V / 50 Hz	<input type="radio"/> 120V / 60Hz
		<input type="radio"/> 12 V DC	<input checked="" type="radio"/> 24 V DC
		<input type="radio"/> Other (specified in blank below)	

DC 24.0V

### 2.4. Short description of the Equipment under Test (EUT)

This is a POS Device.

For more details, refer to the user's manual of the EUT.

### 2.5. EUT operation mode

The Applicant provides communication tools software to control the EUT for staying in continuous transmitting (Duty Cycle more than 98%) and receiving mode for testing .There are 79 channels provided to the EUT. Channel 00/39/78 was selected to test.

Mode of Operations	Frequency Range (MHz)	Data Rate (Mbps)
(BDR/EDR)	2402	1/2/3
	2441	1/2/3
	2480	1/2/3
For Conducted Emission		
Test Mode		TX Mode
For Radiated Emission		
Test Mode		TX Mode

Channel	Frequency(MHz)	Channel	Frequency(MHz)
<b>00</b>	<b>2402</b>	40	2442
01	2403	41	2443
02	2404	42	2444
--	--	--	--
--	--	--	--
<b>38</b>	2440	<b>78</b>	<b>2480</b>
39	2441		

AC conducted emission pre-test at both at AC 120V/60Hz and AC 240V/60Hz modes, recorded worst case.

Worst-case mode and channel used for 150 KHz-30 MHz power line conducted emissions was the mode and channel with the highest output power that was determined to be TX (1Mbps).

Worst-case mode and channel used for 9 KHz-1000 MHz radiated emissions was the mode and channel with the highest output power, that was determined to be TX(1Mbps-MCH).

## 2.6. Block Diagram of Test Setup

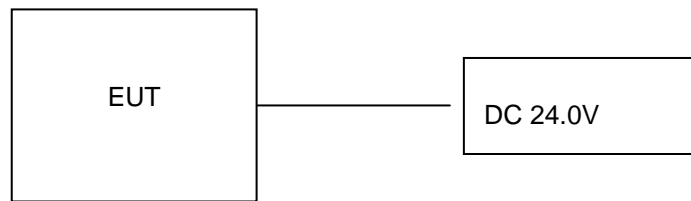

## 2.7. Related Submittal(s) / Grant (s)

This submittal(s) (test report) is intended for **FCC ID: 2AYD5-I23D02** filing to comply with Section 15.247 of the FCC Part 15, Subpart C Rules.

## 2.8. EUT Exercise Software

The system enters the engineering mode through the instructions provided by the application (adb model), tests under continuous transmission conditions, and changes the test channel.

## 2.9. Special Accessories

Manufacturer	Description	Model	Serial Number	Certificate
SHENZHEN HONOR ELECTRONIC CO.,LTD.	Adapter	ADS-65HI-19A-124036E	--	SDOC
Shenzhen SOY Technology Co.,Ltd.	Adapter	SOY-2400150-332-A	--	SDOC
Jiangsu Chenyang Electron Co.,Ltd.	Adapter	CYZS36-240150	--	SDOC
LENOVO	PC	DESKYOP-EUIVCNR	--	SDOC
LENOVO	Keyboard	T460S	--	SDOC
LENOVO	Mouse	Howard	--	SDOC
aigo	USB flash disk	U330	--	SDOC

Note: The PC, Keyboard, Mouse and USB flash disk is only used for auxiliary testing.

## 2.10. External I/O Cable

I/O Port Description	Quantity	Cable
DC IN Port	1	Non-Shielded, 1.0m
USB Port	3	N/A
LAN Port	1	Non-Shielded, 10m
TF Cart	1	N/A
RJ11 Port	1	N/A
RJ12 Port	1	N/A

## 2.11. Modifications

No modifications were implemented to meet testing criteria.



### 3. TEST ENVIRONMENT

#### 3.1. Address of the test laboratory

##### Shenzhen Global Test Service Co.,Ltd.

No.7-101 and 8A-104, Building 7 and 8, DCC Cultural and Creative Garden, No.98, Pingxin North Road, Shangmugu Community, Pinghu Street, Longgang District, Shenzhen, Guangdong,China.

#### 3.2. Test Facility

The test facility is recognized, certified, or accredited by the following organizations:

CNAS (No. CNAS L8169)

Shenzhen Global Test Service Co., Ltd. has been assessed and proved to be in compliance with CNAS-CL01 Accreditation Criteria for Testing and Calibration Laboratories (identical to ISO/IEC 17025: 2019 General Requirements) for the Competence of Testing and Calibration Laboratories.

A2LA (Certificate No. 4758.01)

Shenzhen Global Test Service Co., Ltd. has been assessed by the American Association for Laboratory Accreditation (A2LA). Certificate No. 4758.01.

Industry Canada Registration Number. is 24189.

FCC Designation Number is CN1234.

FCC Registered Test Site Number is165725.

#### 3.3. Environmental conditions

During the measurement the environmental conditions were within the listed ranges:

Temperature:	15-35 ° C
Humidity:	30-60 %
Atmospheric pressure:	950-1050mbar

#### 3.4. Statement of the measurement uncertainty

The data and results referenced in this document are true and accurate. The reader is cautioned that there may be errors within the calibration limits of the equipment and facilities. The measurement uncertainty was calculated for all measurements listed in this test report acc. to CISPR 16 - 4 „Specification for radio disturbance and immunity measuring apparatus and methods – Part 4: Uncertainty in EMC Measurements“ and is documented in the Shenzhen Global Test Service Co.,Ltd. quality system acc. to DIN EN ISO/IEC 17025. Furthermore, component and process variability of devices similar to that tested may result in additional deviation. The manufacturer has the sole responsibility of continued compliance of the device.

Hereafter the best measurement capability for Shenzhen GTS laboratory is reported:

Test	Range	Measurement Uncertainty	Notes
Radiated Emission	30~1000MHz	4.10 dB	(1)
Radiated Emission	1~18GHz	4.32 dB	(1)
Radiated Emission	18-40GHz	5.54 dB	(1)
Conducted Disturbance	0.15~30MHz	3.12 dB	(1)

This uncertainty represents an expanded uncertainty expressed at approximately the 95% confidence level using a coverage factor of k=2.

### 3.5. Summary of measurement results

Applied Standard: FCC Part 15 Subpart C				
FCC Rules	Description of Test	Test Sample	Result	Remark
§15.247(b)(1)	Maximum Conducted Output Power	GTS20230704026-1-S0001-3#	Compliant	Appendix A
§15.247(c)	Frequency Separation	GTS20230704026-1-S0001-3#	Compliant	Appendix A
§15.247(c)	99% and 20 dB Bandwidth	GTS20230704026-1-S0001-3#	Compliant	Appendix A
§15.247(a)(1)(ii)	Number of Hopping Frequency	GTS20230704026-1-S0001-3#	Compliant	Appendix A
§15.247(a)(1)(iii)	Time Of Occupancy (Dwell Time)	GTS20230704026-1-S0001-3#	Compliant	Appendix A
§15.209, §15.205	Conducted Spurious Emissions and Band Edges Test	GTS20230704026-1-S0001-3#	Compliant	Appendix A
§15.209, §15.247(d)	Radiated Spurious Emissions	GTS20230704026-1-S0001-3# GTS20230704026-1-S0001-4# GTS20230704026-1-S0001-5#	Compliant	Note 1
§15.205	Emissions at Restricted Band	GTS20230704026-1-S0001-3#	Compliant	Note 1
§15.207(a)	AC Conducted Emissions	GTS20230704026-1-S0001-4# GTS20230704026-1-S0001-5#	Compliant	Note 1
§15.203 §15.247(c)	Antenna Requirements	GTS20230704026-1-S0001-3#	Compliant	Note 1
§15.247(i)§2.10 91	RF Exposure	/	Compliant	Note 2

Remark:

1. The measurement uncertainty is not included in the test result.
2. NA = Not Applicable; NP = Not Performed
3. Note 1 – Test results inside test report;
4. Note 2 – Test results in other test report (MPE Report).
5. We tested all test mode and recorded worst case in report

### 3.6. Equipments Used during the Test

Test Equipment	Manufacturer	Model No.	Serial No.	Calibration Date	Calibration Due Date
LISN	CYBERTEK	EM5040A	E1850400105	2023/07/13	2024/07/12
LISN	R&S	ESH2-Z5	893606/008	2023/07/13	2024/07/12
EMI Test Receiver	R&S	ESPI3	101841-cd	2023/07/13	2024/07/12
EMI Test Receiver	R&S	ESCI7	101102	2022/09/09	2023/09/08
Spectrum Analyzer	Agilent	N9020A	MY48010425	2022/09/09	2023/09/08
Spectrum Analyzer	R&S	FSV40	100019	2023/07/13	2024/07/12
Vector Signal generator	Agilent	N5181A	MY49060502	2023/07/13	2024/07/12
Signal generator	Agilent	N5182A	3610AO1069	2022/09/09	2023/09/08
Climate Chamber	ESPEC	EL-10KA	A20120523	2022/09/09	2023/09/08
Controller	EM Electronics	Controller EM 1000	N/A	N/A	N/A
Horn Antenna	Schwarzbeck	BBHA 9120D	01622	2022/09/09	2023/09/08
Active Loop Antenna	Beijing Da Ze Technology Co.,Ltd.	ZN30900C	15006	2022/09/09	2023/09/08
Bilog Antenna	Schwarzbeck	VULB9163	000976	2023/07/13	2024/07/12
Broadband Horn Antenna	SCHWARZBECK	BBHA 9170	791	2022/09/09	2023/09/08
Amplifier	Schwarzbeck	BBV 9743	#202	2023/07/13	2024/07/12
Amplifier	Schwarzbeck	BBV9179	9719-025	2023/07/13	2024/07/12
Amplifier	EMCI	EMC051845B	980355	2023/07/13	2024/07/12
Temperature/Humidity Meter	Gangxing	CTH-608	02	2023/07/13	2024/07/12
High-Pass Filter	K&L	9SH10-2700/X12750-O/O	KL142031	2023/07/13	2024/07/12
High-Pass Filter	K&L	41H10-1375/U12750-O/O	KL142032	2023/07/13	2024/07/12
RF Cable(below 1GHz)	HUBER+SUHNER	RG214	RE01	2023/07/13	2024/07/12
RF Cable(above 1GHz)	HUBER+SUHNER	RG214	RE02	2023/07/13	2024/07/12
Data acquisition card	Agilent	U2531A	TW53323507	2023/07/13	2024/07/12
Power Sensor	Agilent	U2021XA	MY5365004	2023/07/13	2024/07/12
Test Control Unit	Tonscend	JS0806-1	178060067	2023/07/13	2024/07/12
Automated filter bank	Tonscend	JS0806-F	19F8060177	2023/07/13	2024/07/12
EMI Test Software	Tonscend	JS1120-1	Ver 2.6.8.0518	/	/
EMI Test Software	Tonscend	JS1120-3	Ver 2.5.77.0418	/	/
EMI Test Software	Tonscend	JS32-CE	Ver 2.5	/	/
EMI Test Software	Tonscend	JS32-RE	Ver 2.5.1.8	/	/

Note: The Cal.Interval was one year.

## 4. TEST CONDITIONS AND RESULTS

### 4.1. AC Power Conducted Emission

#### TEST CONFIGURATION

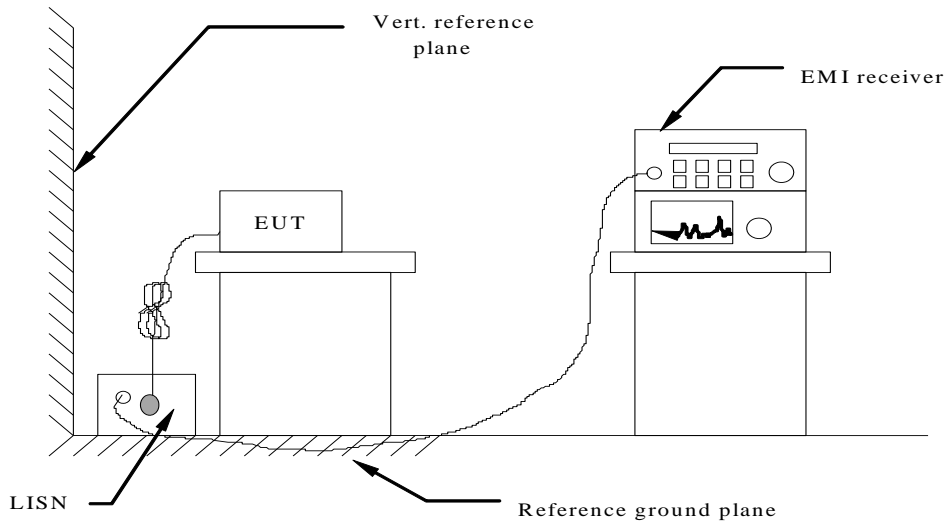

#### TEST PROCEDURE

- 1 The equipment was set up as per the test configuration to simulate typical actual usage per the user's manual. The EUT is a tabletop system, a wooden table with a height of 0.8 meters is used and is placed on the ground plane as per ANSI C63.10-2020.
- 2 Support equipment, if needed, was placed as per ANSI C63.10-2020.
- 3 All I/O cables were positioned to simulate typical actual usage as per ANSI C63.10-2020.
- 4 The EUT received DC 24.0V power, the Adapter received AC120V/60Hz or AC 240V/60Hz power through a Line Impedance Stabilization Network (LISN) which supplied power source and was grounded to the ground plane.
- 6 The EUT test program was started. Emissions were measured on each current carrying line of the EUT using a spectrum Analyzer / Receiver connected to the LISN powering the EUT. The LISN has two monitoring points: Line 1 (Hot Side) and Line 2 (Neutral Side). Two scans were taken: one with Line 1 connected to Analyzer / Receiver and Line 2 connected to a 50 ohm load; the second scan had Line 1 connected to a 50 ohm load and Line 2 connected to the Analyzer / Receiver.
- 7 Analyzer / Receiver scanned from 150 KHz to 30MHz for emissions in each of the test modes.
- 8 During the above scans, the emissions were maximized by cable manipulation.

#### AC Power Conducted Emission Limit

For intentional device, according to § 15.207(a) AC Power Conducted Emission Limits is as following :

Frequency range (MHz)	Limit (dBuV)	
	Quasi-peak	Average
0.15-0.5	66 to 56*	56 to 46*
0.5-5	56	46
5-30	60	50

\* Decreases with the logarithm of the frequency.

#### TEST RESULTS

Remark: We measured Conducted Emission at GFSK,  $\pi/4$ -DQPSK and 8DPSK mode in AC 120V/60Hz and AC 240V/60Hz, the worst case was recorded(GFSK 1Mbps-MCH) .

Temperature	26°C	Humidity	47%
Test Engineer	Evan Ouyang	Configurations	BT

Version A:  
 Adapter: ADS-65HI-19A-124036E

Power supply:	AC 120V/60Hz	Polarization	L
---------------	--------------	--------------	---

Test Graph

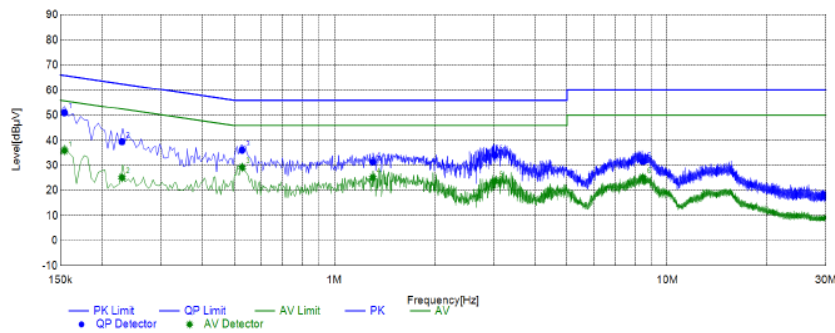

Final Data List												
NO.	Frequency	QP	AVG.	Factor	QP	AVG.	QP	AVG.	QP	AVG.	Line	Remark
		Reading	Reading		Result	Result	Limit	Limit	Margin	Margin		
1	0.1543	41.02	25.91	9.95	50.97	35.86	65.77	55.77	14.80	19.91	L1	PASS
2	0.2300	29.71	15.44	9.77	39.48	25.21	62.45	52.45	22.97	27.24	L1	PASS
3	0.5282	26.36	19.51	9.69	36.05	29.20	56.00	46.00	19.95	16.80	L1	PASS
4	1.3062	21.70	15.56	9.68	31.38	25.24	56.00	46.00	24.62	20.76	L1	PASS
5	3.0366	24.31	14.04	9.77	34.08	23.81	56.00	46.00	21.92	22.19	L1	PASS
6	8.4515	21.82	15.52	9.71	31.53	25.23	60.00	50.00	28.47	24.77	L1	PASS

Note: 1. Result (dBµV) = Reading (dBµV) + Factor (dB).

2. Factor (dB) = Cable loss (dB) + LISN Factor (dB).

Power supply:	AC 120V/60Hz	Polarization	N
---------------	--------------	--------------	---

Test Graph

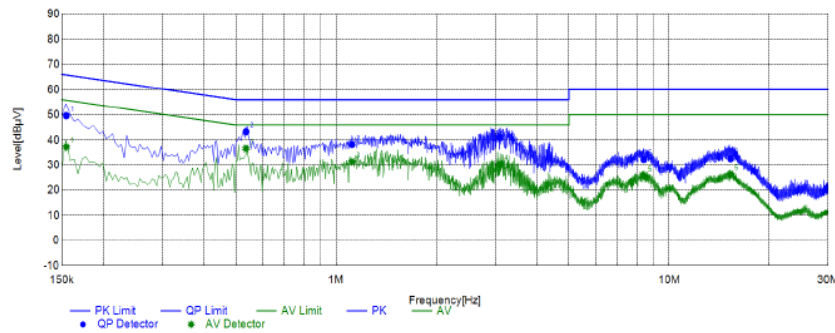

Final Data List												
NO.	Frequency	QP	AVG.	Factor	QP	AVG.	QP	AVG.	QP	AVG.	Line	Remark
		Reading	Reading		Result	Result	Limit	Limit	Margin	Margin		
1	0.1548	39.85	27.37	9.79	49.64	37.16	65.74	55.74	16.10	18.58	N	PASS
2	0.5364	33.54	26.86	9.68	43.22	36.54	56.00	46.00	12.78	9.46	N	PASS
3	1.1171	28.42	21.64	9.67	38.09	31.31	56.00	46.00	17.91	14.69	N	PASS
4	3.1118	31.23	20.53	9.76	40.99	30.29	56.00	46.00	15.01	15.71	N	PASS
5	8.3911	22.57	16.08	9.71	32.28	25.79	60.00	50.00	27.72	24.21	N	PASS
6	15.2927	23.35	17.14	9.23	32.58	26.37	60.00	50.00	27.42	23.63	N	PASS

Note: 1. Result (dBµV) = Reading (dBµV) + Factor (dB).

2. Factor (dB) = Cable loss (dB) + LISN Factor (dB).

Adapter: SOY-2400150-332-A

Power supply:	AC 120V/60Hz	Polarization	L
---------------	--------------	--------------	---

Test Graph

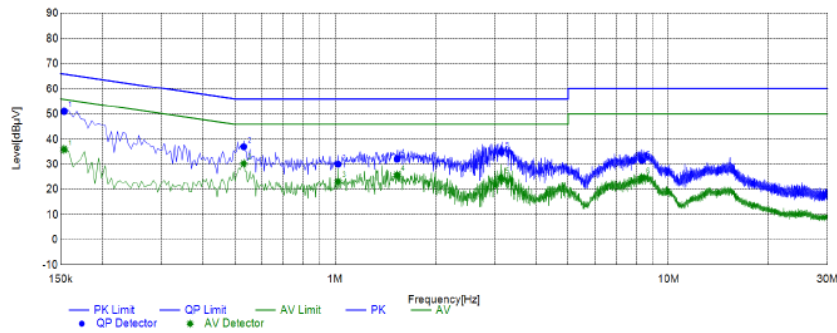

Final Data List												
NO.	Frequency	QP	AVG.	Factor	QP	AVG.	QP	AVG.	QP	AVG.	Line	Remark
		Reading	Reading		Result	Result	Limit	Limit	Margin	Margin		
1	0.1538	41.09	25.94	9.95	51.04	35.89	65.79	55.79	14.75	19.90	L1	PASS
2	0.5320	27.26	20.61	9.69	36.95	30.30	56.00	46.00	19.05	15.70	L1	PASS
3	1.0217	20.40	13.50	9.67	30.07	23.17	56.00	46.00	25.93	22.83	L1	PASS
4	1.5339	22.46	16.06	9.69	32.15	25.75	56.00	46.00	23.85	20.25	L1	PASS
5	3.1497	25.21	14.87	9.76	34.97	24.63	56.00	46.00	21.03	21.37	L1	PASS
6	8.3158	21.82	15.05	9.70	31.52	24.75	60.00	50.00	28.48	25.25	L1	PASS

Note: 1. Result (dBµV) = Reading (dBµV) + Factor (dB).

2. Factor (dB) = Cable loss (dB) + LISN Factor (dB).

Power supply:	AC 120V/60Hz	Polarization	N
---------------	--------------	--------------	---

Test Graph

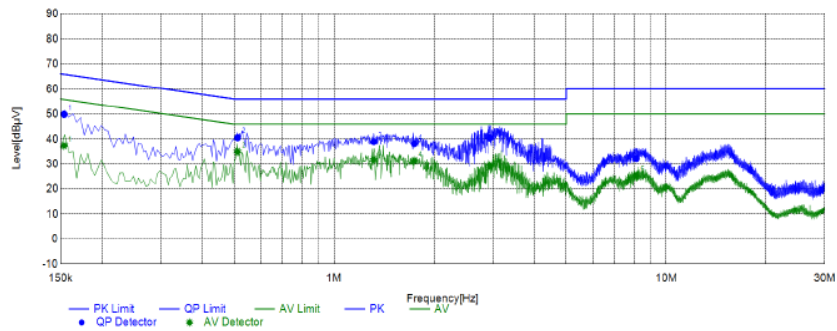

Final Data List												
NO.	Frequency	QP	AVG.	Factor	QP	AVG.	QP	AVG.	QP	AVG.	Line	Remark
		Reading	Reading		Result	Result	Limit	Limit	Margin	Margin		
1	0.1538	40.06	27.58	9.79	49.85	37.37	65.79	55.79	15.94	18.42	N	PASS
2	0.5121	30.87	25.28	9.68	40.55	34.96	56.00	46.00	15.45	11.04	N	PASS
3	1.3173	29.22	22.09	9.67	38.89	31.76	56.00	46.00	17.11	14.24	N	PASS
4	1.7430	28.37	21.57	9.70	38.07	31.27	56.00	46.00	17.93	14.73	N	PASS
5	2.9410	30.71	19.47	9.76	40.47	29.23	56.00	46.00	15.53	16.77	N	PASS
6	8.1376	22.55	15.77	9.71	32.26	25.48	60.00	50.00	27.74	24.52	N	PASS

Note: 1. Result (dBµV) = Reading (dBµV) + Factor (dB).

2. Factor (dB) = Cable loss (dB) + LISN Factor (dB).

Adapter: CYZS36-240150

Power supply:	AC 120V/60Hz	Polarization	L
---------------	--------------	--------------	---

Test Graph

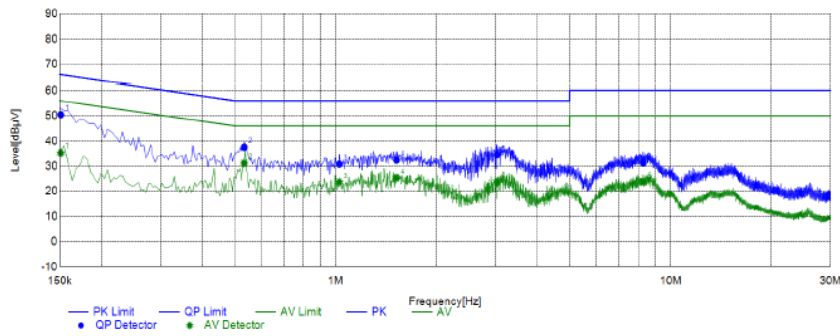

Final Data List												
NO.	Frequency	QP	AVG.	Factor	QP	AVG.	QP	AVG.	QP	AVG.	Line	Remark
		Reading	Reading		Result	Result	Limit	Limit	Margin	Margin		
1	0.1512	40.48	25.29	9.96	50.44	35.25	65.93	55.93	15.49	20.68	L1	PASS
2	0.5334	27.81	21.51	9.69	37.50	31.20	56.00	46.00	18.50	14.80	L1	PASS
3	1.0243	21.16	13.95	9.67	30.83	23.62	56.00	46.00	25.17	22.38	L1	PASS
4	1.5190	22.72	15.62	9.69	32.41	25.31	56.00	46.00	23.59	20.69	L1	PASS
5	3.0360	24.70	14.20	9.77	34.47	23.97	56.00	46.00	21.53	22.03	L1	PASS
6	8.2943	21.57	14.05	9.70	31.27	23.75	60.00	50.00	28.73	26.25	L1	PASS

Note: 1. Result (dBµV) = Reading (dBµV) + Factor (dB).

2. Factor (dB) = Cable loss (dB) + LISN Factor (dB).

Power supply:	AC 120V/60Hz	Polarization	N
---------------	--------------	--------------	---

Test Graph

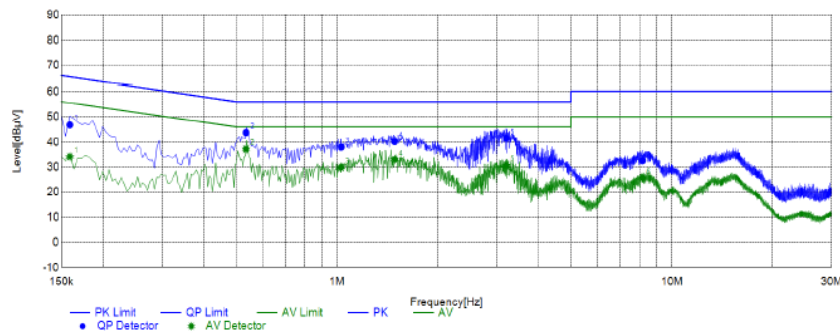

Final Data List												
NO.	Frequency	QP	AVG.	Factor	QP	AVG.	QP	AVG.	QP	AVG.	Line	Remark
		Reading	Reading		Result	Result	Limit	Limit	Margin	Margin		
1	0.1591	37.00	24.31	9.79	46.79	34.10	65.51	55.51	18.72	21.41	N	PASS
2	0.5346	34.06	27.50	9.68	43.74	37.18	56.00	46.00	12.26	8.82	N	PASS
3	1.0284	28.33	20.23	9.66	37.99	29.89	56.00	46.00	18.01	16.11	N	PASS
4	1.4849	30.50	23.33	9.69	40.19	33.02	56.00	46.00	15.81	12.98	N	PASS
5	3.2020	31.68	20.86	9.77	41.45	30.63	56.00	46.00	14.55	15.37	N	PASS
6	8.1731	22.81	16.03	9.71	32.52	25.74	60.00	50.00	27.48	24.26	N	PASS

Note: 1. Result (dBµV) = Reading (dBµV) + Factor (dB).

2. Factor (dB) = Cable loss (dB) + LISN Factor (dB).

Version B:  
 Adapter: ADS-65HI-19A-124036E

Power supply:	AC 120V/60Hz	Polarization	L
---------------	--------------	--------------	---

Test Graph

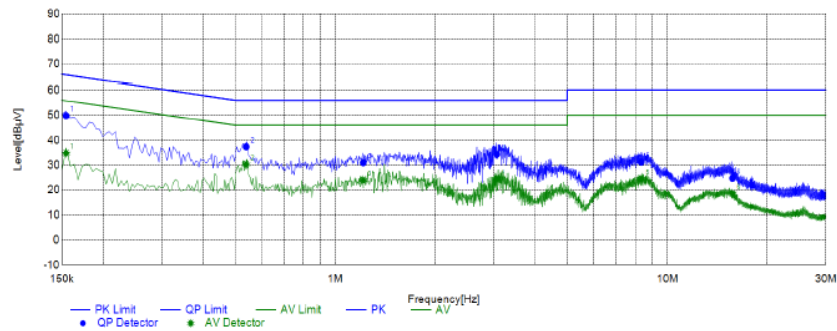

Final Data List												
NO.	Frequency	QP	AVG.	Factor	QP	AVG.	QP	AVG.	QP	AVG.	Line	Remark
		Reading	Reading		Result	Result	Limit	Limit	Margin	Margin		
1	0.1544	39.81	24.81	9.95	49.76	34.76	65.76	55.76	16.00	21.00	L1	PASS
2	0.5394	27.68	20.61	9.69	37.37	30.30	56.00	46.00	18.63	15.70	L1	PASS
3	1.2133	21.28	14.29	9.68	30.96	23.97	56.00	46.00	25.04	22.03	L1	PASS
4	3.0648	24.53	14.68	9.77	34.30	24.45	56.00	46.00	21.70	21.55	L1	PASS
5	8.3502	21.48	14.80	9.71	31.19	24.51	60.00	50.00	28.81	25.49	L1	PASS
6	15.7093	15.56	9.53	9.15	24.71	18.68	60.00	50.00	35.29	31.32	L1	PASS

Note: 1. Result (dBµV) = Reading (dBµV) + Factor (dB).

2. Factor (dB) = Cable loss (dB) + LISN Factor (dB).

Power supply:	AC 120V/60Hz	Polarization	N
---------------	--------------	--------------	---

Test Graph

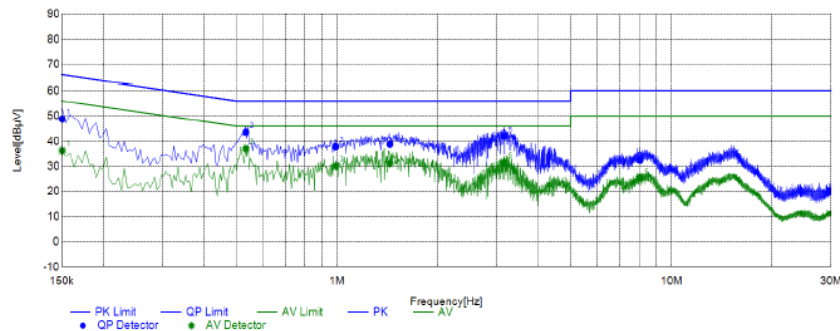

Final Data List												
NO.	Frequency	QP	AVG.	Factor	QP	AVG.	QP	AVG.	QP	AVG.	Line	Remark
		Reading	Reading		Result	Result	Limit	Limit	Margin	Margin		
1	0.1507	39.04	26.51	9.79	48.83	36.30	65.96	55.96	17.13	19.66	N	PASS
2	0.5337	33.93	27.40	9.68	43.61	37.08	56.00	46.00	12.39	8.92	N	PASS
3	0.9903	28.22	20.53	9.66	37.88	30.19	56.00	46.00	18.12	15.81	N	PASS
4	1.4389	29.10	21.44	9.68	38.78	31.12	56.00	46.00	17.22	14.88	N	PASS
5	3.1592	32.14	21.88	9.77	41.91	31.65	56.00	46.00	14.09	14.35	N	PASS
6	8.0591	22.67	15.81	9.71	32.38	25.52	60.00	50.00	27.62	24.48	N	PASS

Note: 1. Result (dBµV) = Reading (dBµV) + Factor (dB).

2. Factor (dB) = Cable loss (dB) + LISN Factor (dB).



Adapter: SOY-2400150-332-A

Power supply:	AC 120V/60Hz	Polarization	L
---------------	--------------	--------------	---

Test Graph

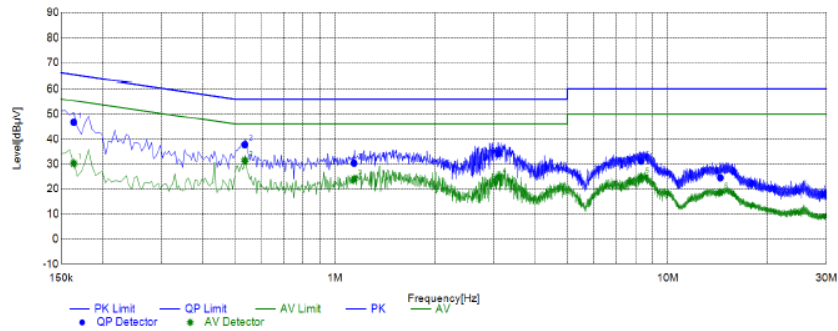

Final Data List												
NO.	Frequency	QP	AVG.	Factor	QP	AVG.	QP	AVG.	QP	AVG.	Line	Remark
		Reading	Reading		Result	Result	Limit	Limit	Margin	Margin		
1	0.1638	36.72	20.35	9.92	46.64	30.27	65.27	55.27	18.63	25.00	L1	PASS
2	0.5362	28.07	21.71	9.69	37.76	31.40	56.00	46.00	18.24	14.60	L1	PASS
3	1.1413	20.67	14.22	9.68	30.35	23.90	56.00	46.00	25.65	22.10	L1	PASS
4	3.0969	24.34	14.94	9.77	34.11	24.71	56.00	46.00	21.89	21.29	L1	PASS
5	8.3219	21.45	15.10	9.70	31.15	24.80	60.00	50.00	28.85	25.20	L1	PASS
6	14.4013	15.20	9.45	9.26	24.46	18.71	60.00	50.00	35.54	31.29	L1	PASS

Note: 1. Result (dBµV) = Reading (dBµV) + Factor (dB).

2. Factor (dB) = Cable loss (dB) + LISN Factor (dB).

Power supply:	AC 120V/60Hz	Polarization	N
---------------	--------------	--------------	---

Test Graph

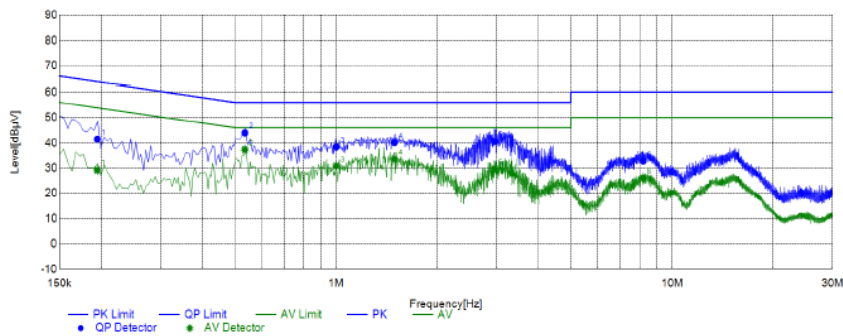

Final Data List												
NO.	Frequency	QP	AVG.	Factor	QP	AVG.	QP	AVG.	QP	AVG.	Line	Remark
		Reading	Reading		Result	Result	Limit	Limit	Margin	Margin		
1	0.1946	31.63	19.43	9.80	41.43	29.23	63.84	53.84	22.41	24.61	N	PASS
2	0.5352	34.29	27.68	9.68	43.97	37.36	56.00	46.00	12.03	8.64	N	PASS
3	1.0005	28.73	21.19	9.66	38.39	30.85	56.00	46.00	17.61	15.15	N	PASS
4	1.4918	30.40	23.94	9.69	40.09	33.63	56.00	46.00	15.91	12.37	N	PASS
5	2.9604	30.77	19.89	9.76	40.53	29.65	56.00	46.00	15.47	16.35	N	PASS
6	8.2090	23.07	16.52	9.72	32.79	26.24	60.00	50.00	27.21	23.76	N	PASS

Note: 1. Result (dBµV) = Reading (dBµV) + Factor (dB).

2. Factor (dB) = Cable loss (dB) + LISN Factor (dB).

Adapter: CYZS36-240150

Power supply:	AC 120V/60Hz	Polarization	L
---------------	--------------	--------------	---

Test Graph

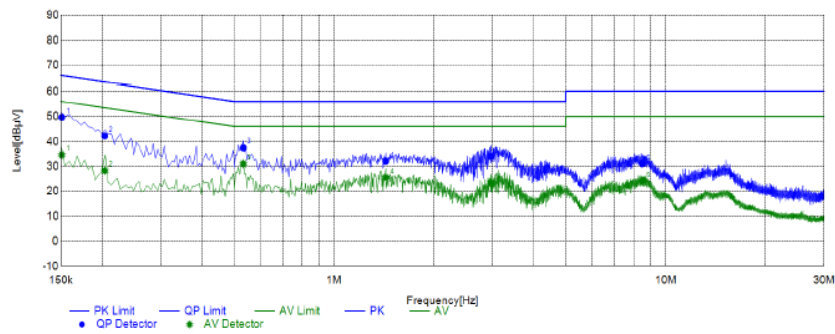

Final Data List												
NO.	Frequency	QP	AVG.	Factor	QP	AVG.	QP	AVG.	QP	AVG.	Line	Remark
		Reading	Reading		Result	Result	Limit	Limit	Margin	Margin		
1	0.1511	39.68	24.62	9.96	49.64	34.58	65.94	55.94	16.30	21.36	L1	PASS
2	0.2036	32.39	18.50	9.81	42.20	28.31	63.46	53.46	21.26	25.15	L1	PASS
3	0.5324	27.77	21.32	9.69	37.46	31.01	56.00	46.00	18.54	14.99	L1	PASS
4	1.4328	22.37	15.75	9.69	32.06	25.44	56.00	46.00	23.94	20.56	L1	PASS
5	2.9703	24.17	13.55	9.77	33.94	23.32	56.00	46.00	22.06	22.68	L1	PASS
6	8.4887	21.34	14.41	9.70	31.04	24.11	60.00	50.00	28.96	25.89	L1	PASS

Note: 1. Result (dBµV) = Reading (dBµV) + Factor (dB).

2. Factor (dB) = Cable loss (dB) + LISN Factor (dB).

Power supply:	AC 120V/60Hz	Polarization	N
---------------	--------------	--------------	---

Test Graph

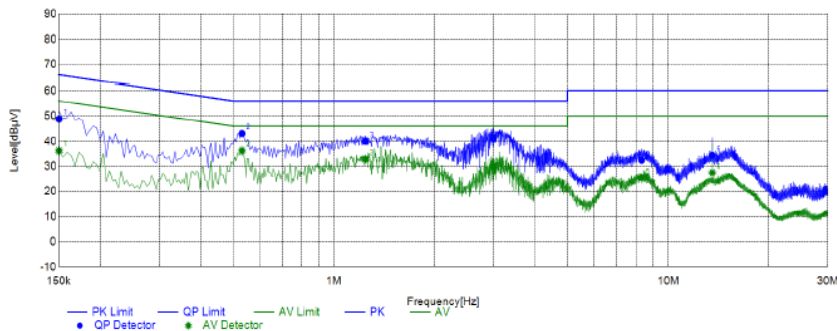

Final Data List												
NO.	Frequency	QP	AVG.	Factor	QP	AVG.	QP	AVG.	QP	AVG.	Line	Remark
		Reading	Reading		Result	Result	Limit	Limit	Margin	Margin		
1	0.1505	39.02	26.44	9.79	48.81	36.23	65.97	55.97	17.16	19.74	N	PASS
2	0.5304	33.43	26.59	9.68	43.11	36.27	56.00	46.00	12.89	9.73	N	PASS
3	1.2430	30.30	23.31	9.67	39.97	32.98	56.00	46.00	16.03	13.02	N	PASS
4	3.0053	31.08	20.34	9.76	40.84	30.10	56.00	46.00	15.16	15.90	N	PASS
5	8.3339	22.71	15.74	9.71	32.42	25.45	60.00	50.00	27.58	24.55	N	PASS
6	13.5611	25.08	18.07	9.36	34.44	27.43	60.00	50.00	25.56	22.57	N	PASS

Note: 1. Result (dBµV) = Reading (dBµV) + Factor (dB).

2. Factor (dB) = Cable loss (dB) + LISN Factor (dB).

## 4.2. Radiated Emission

### TEST CONFIGURATION

Frequency range 9 KHz – 30MHz

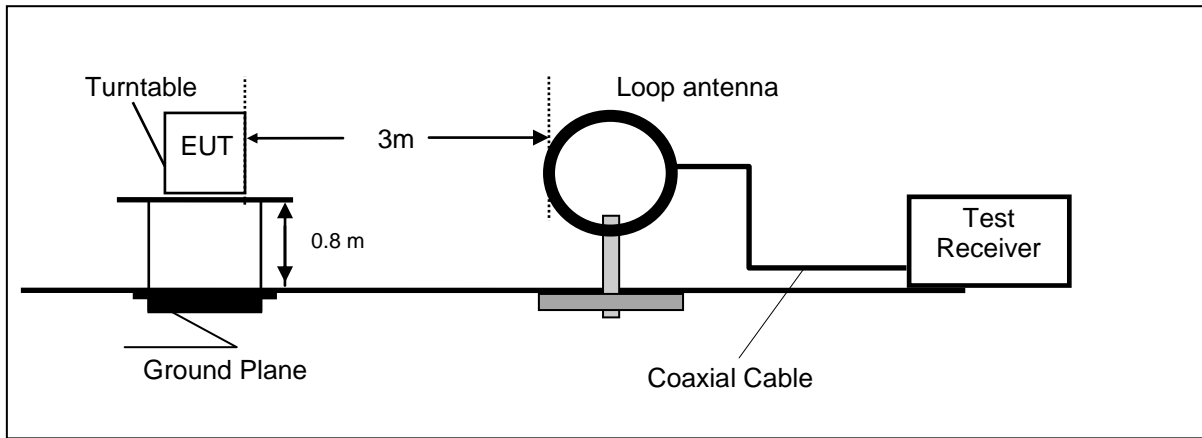

Frequency range 30MHz – 1000MHz

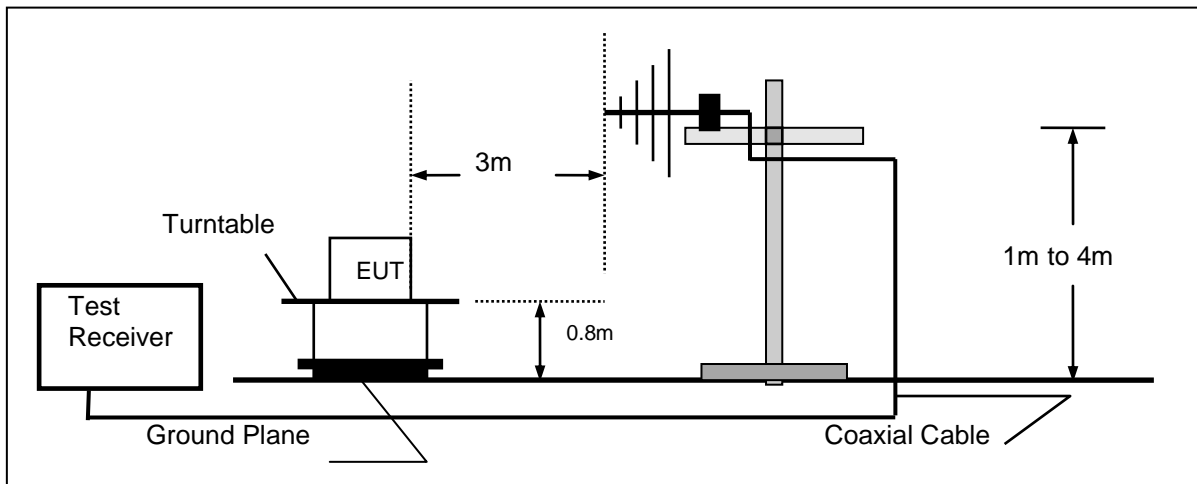

Frequency range above 1GHz-25GHz

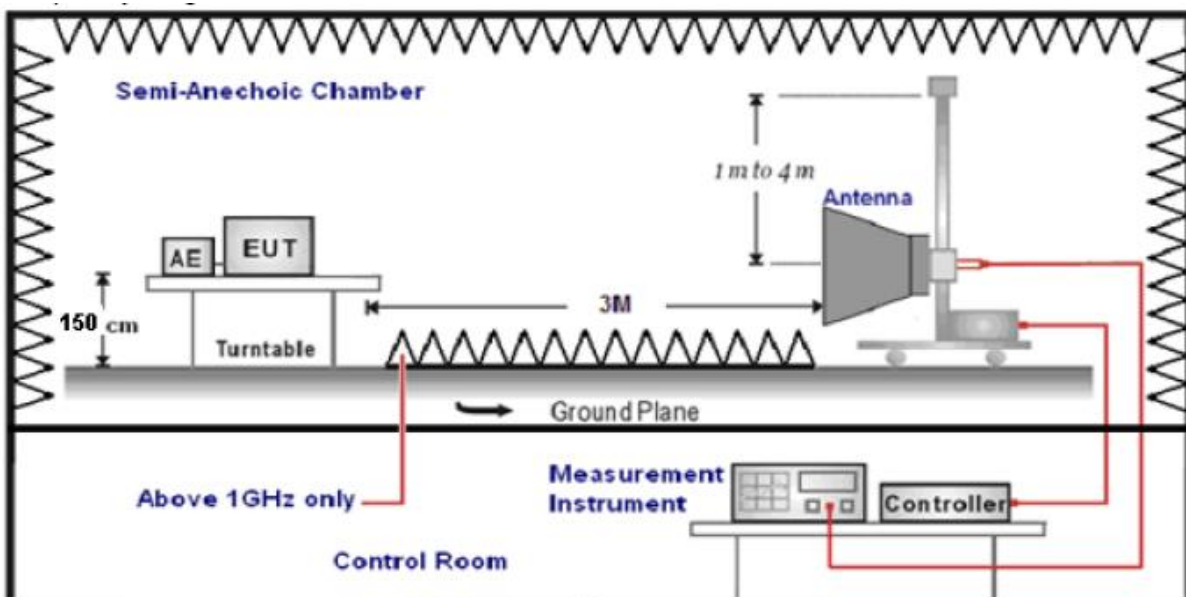

**TEST PROCEDURE**

1. The EUT was placed on a turn table which is 0.8m above ground plane when testing frequency range 9 KHz –1GHz;the EUT was placed on a turn table which is 1.5m above ground plane when testing frequency range 1GHz – 25GHz.
2. Maximum procedure was performed by raising the receiving antenna from 1m to 4m and rotating the turn table from 0°C to 360°C to acquire the highest emissions from EUT.
3. And also, each emission was to be maximized by changing the polarization of receiving antenna both horizontal and vertical.
4. Repeat above procedures until all frequency measurements have been completed.
5. The EUT minimum operation frequency was 32.768KHz and maximum operation frequency was 2480MHz.so radiated emission test frequency band from 9KHz to 25GHz.
6. The distance between test antenna and EUT as following table states:

Test Frequency range	Test Antenna Type	Test Distance
9KHz-30MHz	Active Loop Antenna	3
30MHz-1GHz	Ultra-Broadband Antenna	3
1GHz-18GHz	Double Ridged Horn Antenna	3
18GHz-25GHz	Horn Antenna	1

7. Setting test receiver/spectrum as following table states:

Test Frequency range	Test Receiver/Spectrum Setting	Detector
9KHz-150KHz	RBW=200Hz/VBW=3KHz, Sweep time=Auto	QP
150KHz-30MHz	RBW=9KHz/VBW=100KHz, Sweep time=Auto	QP
30MHz-1GHz	RBW=120KHz/VBW=1000KHz, Sweep time=Auto	QP
1GHz-40GHz	Peak Value: RBW=1MHz/VBW=3MHz, Sweep time=Auto Average Value: RBW=1MHz/VBW=10Hz, Sweep time=Auto	Peak

**Field Strength Calculation**

The field strength is calculated by adding the Antenna Factor and Cable Factor and subtracting the Amplifier Gain and Duty Cycle Correction Factor(if any) from the measured reading. The basic equation with a sample calculation is as follows:

**FS = RA + AF + CL - AG**

Where FS = Field Strength	CL = Cable Attenuation Factor (Cable Loss)
RA = Reading Amplitude	AG = Amplifier Gain
AF = Antenna Factor	

Transd=AF +CL-AG

**RADIATION LIMIT**

For intentional device, according to § 15.209(a), the general requirement of field strength of radiated emission from intentional radiators at a distance of 3 meters shall not exceed the following table. According to § 15.247(d), in any 100kHz bandwidth outside the frequency band in which the EUT is operating, the radio frequency power that is produced by the intentional radiator shall be at least 20dB below that in the 100kHz bandwidth within the band that contains the highest level of desired power.

The pre-test have done for the EUT in three axes and found the worst emission at position shown in test setup photos.

Frequency (MHz)	Distance (Meters)	Radiated (dB $\mu$ V/m)	Radiated ( $\mu$ V/m)
0.009-0.49	3	$20\log(2400/F(\text{KHz}))+40\log(300/3)$	$2400/F(\text{KHz})$
0.49-1.705	3	$20\log(24000/F(\text{KHz}))+40\log(30/3)$	$24000/F(\text{KHz})$
1.705-30	3	$20\log(30)+40\log(30/3)$	30
30-88	3	40.0	100
88-216	3	43.5	150
216-960	3	46.0	200
Above 960	3	54.0	500

**TEST RESULTS**

Remark: We measured Radiated Emission at GFSK,  $\pi/4$ -DQPSK and 8DPSK mode from 9KHz to 25GHz and recorded worst case at GFSK(1Mbps-MCH) mode.

Temperature	26°C	Humidity	47%
Test Engineer	Evan Ouyang	Configurations	BT

**For 9 KHz~30MHz**

Freq. (MHz)	Level (dB $\mu$ V)	Over Limit (dB)	Over Limit (dB $\mu$ V)	Remark
-	-	-	-	See Note

**Note:**

The amplitude of spurious emissions which are attenuated by more than 20 dB below the permissible value has no need to be reported.

Distance extrapolation factor =  $40 \log(\text{specific distance} / \text{test distance})$  (dB);

Limit line = specific limits (dB $\mu$ V) + distance extrapolation factor.

For 30MHz-1GHz  
Version A:

Adapter: ADS-65HI-19A-124036E

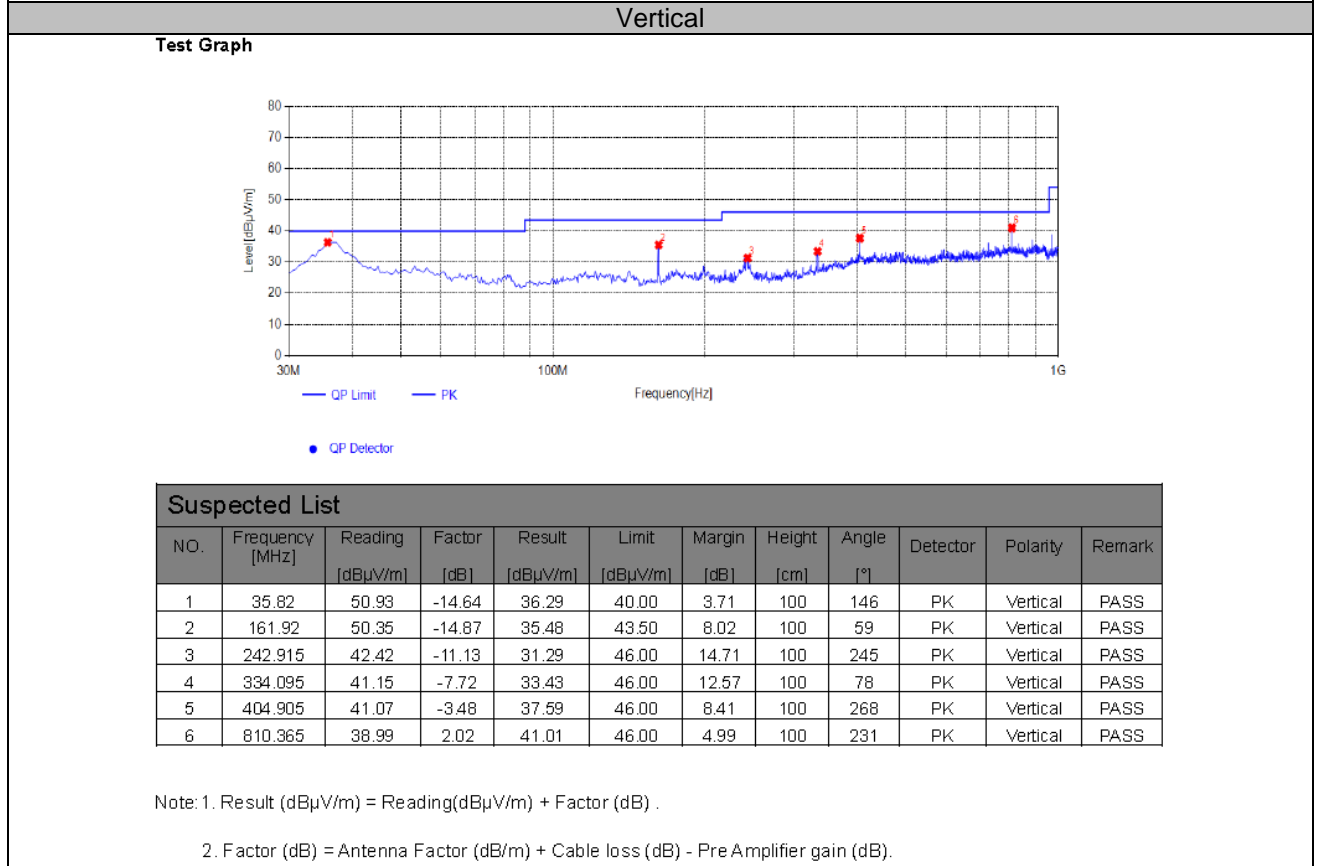
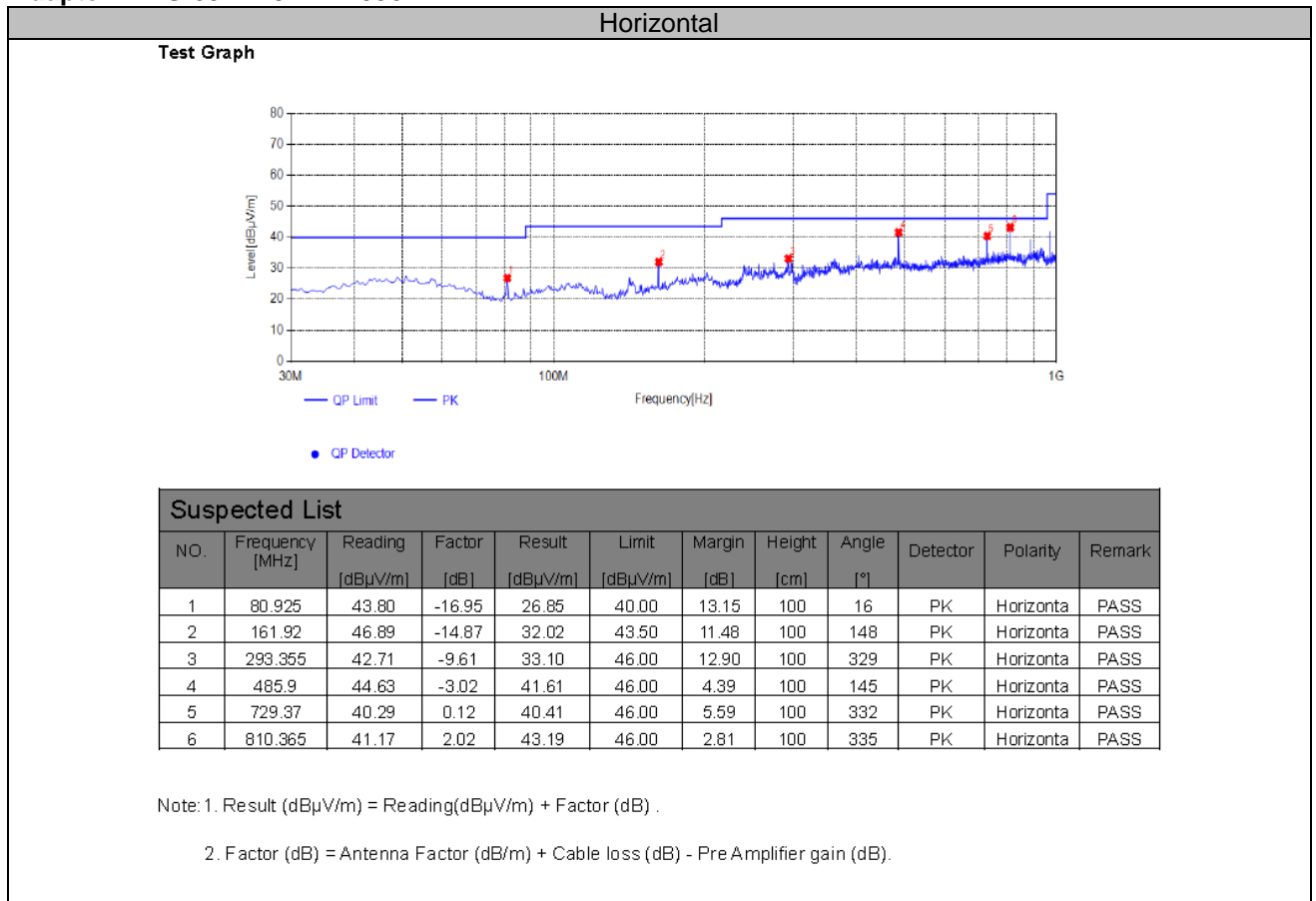

Adapter: SOY-2400150-332-A

**Horizontal**

**Test Graph**

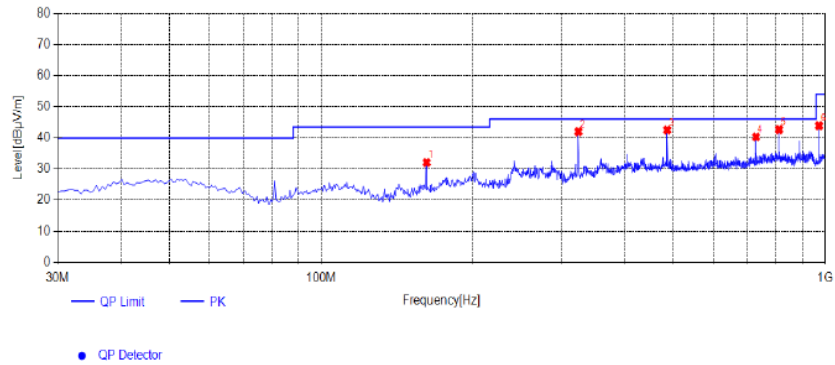

**Suspected List**

NO.	Frequency [MHz]	Reading [dBµV/m]	Factor [dB]	Result [dBµV/m]	Limit [dBµV/m]	Margin [dB]	Height [cm]	Angle [°]	Detector	Polarity	Remark
1	161.92	46.95	-14.87	32.08	43.50	11.42	100	152	PK	Horizontal	PASS
2	323.91	50.42	-8.41	42.01	46.00	3.99	100	324	PK	Horizontal	PASS
3	485.9	45.56	-3.02	42.54	46.00	3.46	100	115	PK	Horizontal	PASS
4	729.37	40.19	0.12	40.31	46.00	5.69	100	334	PK	Horizontal	PASS
5	810.365	40.66	2.02	42.68	46.00	3.32	100	327	PK	Horizontal	PASS
6	972.355	39.64	4.27	43.91	54.00	10.09	100	208	PK	Horizontal	PASS

Note: 1. Result (dBµV/m) = Reading(dBµV/m) + Factor (dB) .

2. Factor (dB) = Antenna Factor (dB/m) + Cable loss (dB) - Pre Amplifier gain (dB).

**Vertical**

**Test Graph**

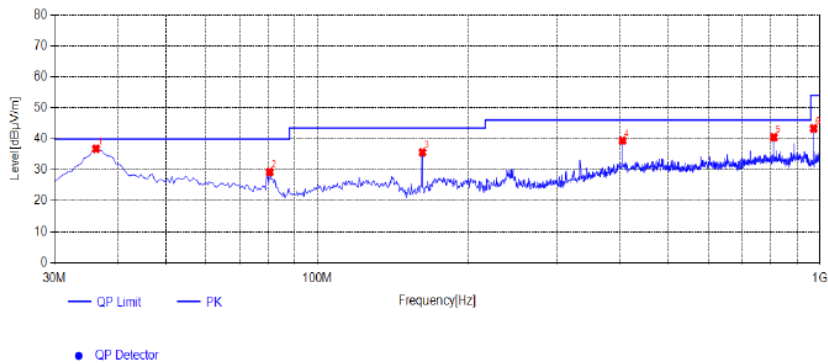

**Suspected List**

NO.	Frequency [MHz]	Reading [dBµV/m]	Factor [dB]	Result [dBµV/m]	Limit [dBµV/m]	Margin [dB]	Height [cm]	Angle [°]	Detector	Polarity	Remark
1	36.305	51.01	-14.28	36.73	40.00	3.27	100	146	PK	Vertical	PASS
2	80.44	46.11	-16.80	29.31	40.00	10.69	100	252	PK	Vertical	PASS
3	161.92	50.46	-14.87	35.59	43.50	7.91	100	49	PK	Vertical	PASS
4	404.905	42.89	-3.48	39.41	46.00	6.59	100	266	PK	Vertical	PASS
5	810.365	38.50	2.02	40.52	46.00	5.48	100	279	PK	Vertical	PASS
6	972.355	39.06	4.27	43.33	54.00	10.67	100	66	PK	Vertical	PASS

Note: 1. Result (dBµV/m) = Reading(dBµV/m) + Factor (dB) .

2. Factor (dB) = Antenna Factor (dB/m) + Cable loss (dB) - Pre Amplifier gain (dB).

Adapter: CYZS36-240150

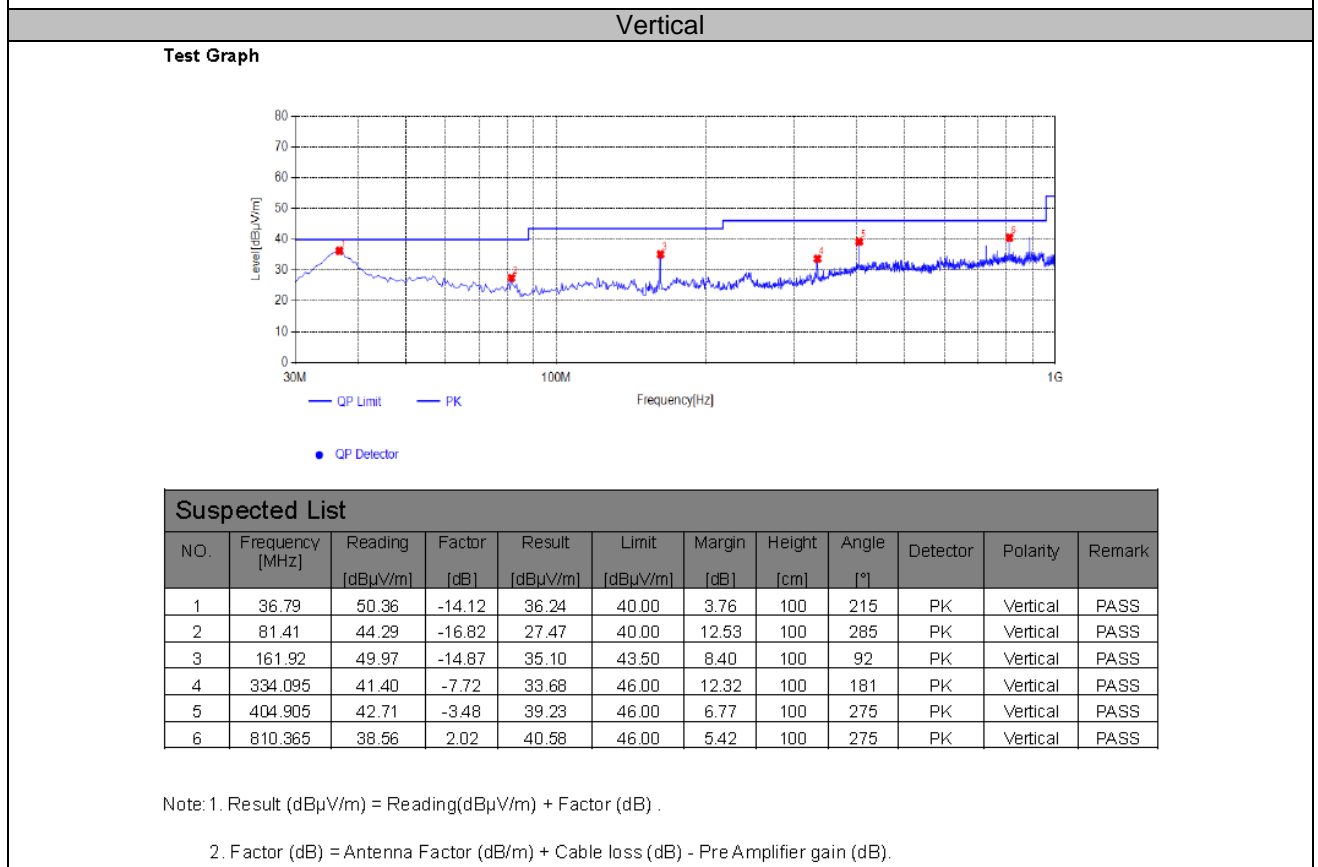
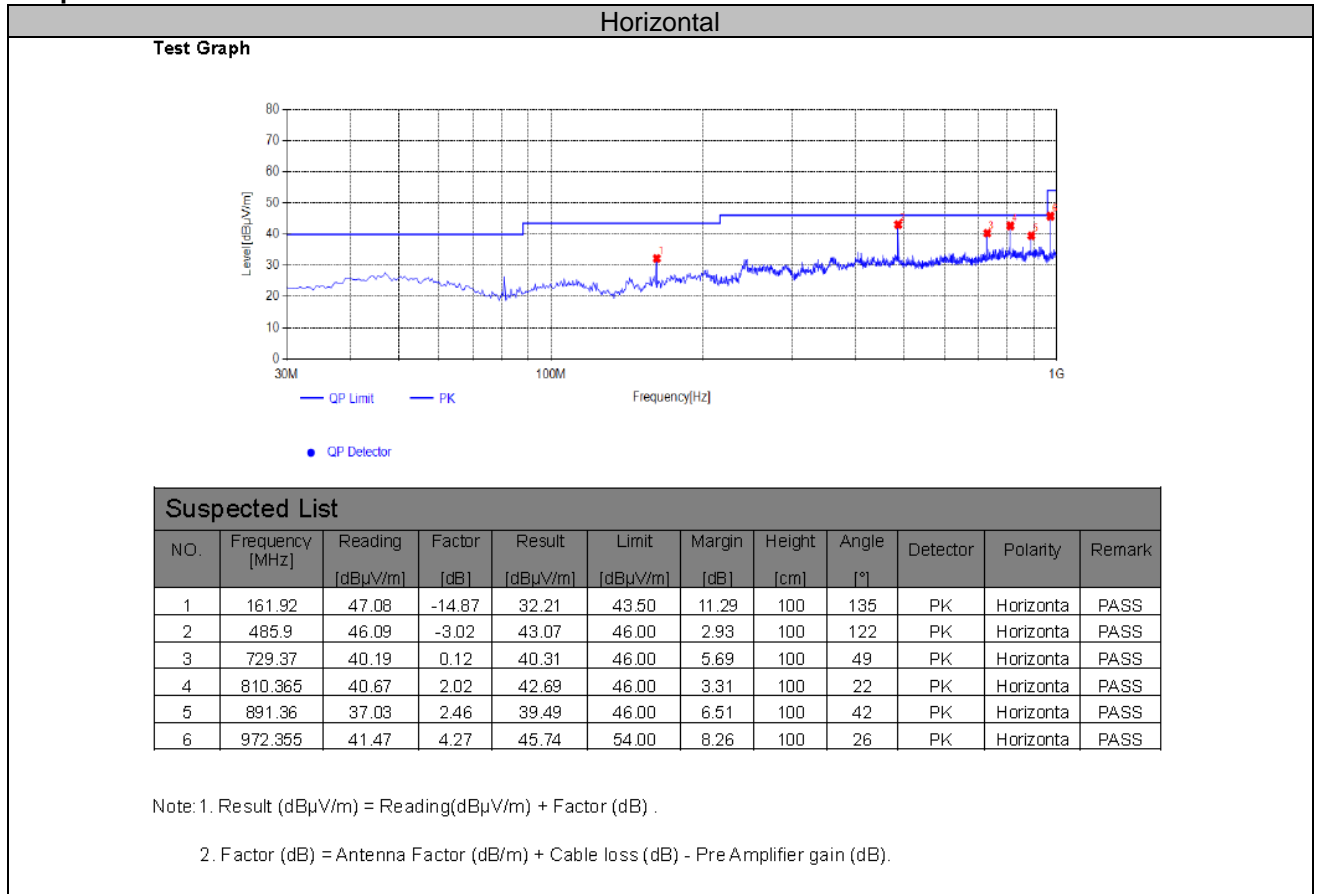



Version B:

Adapter: ADS-65HI-19A-124036E

**Horizontal**

Test Graph

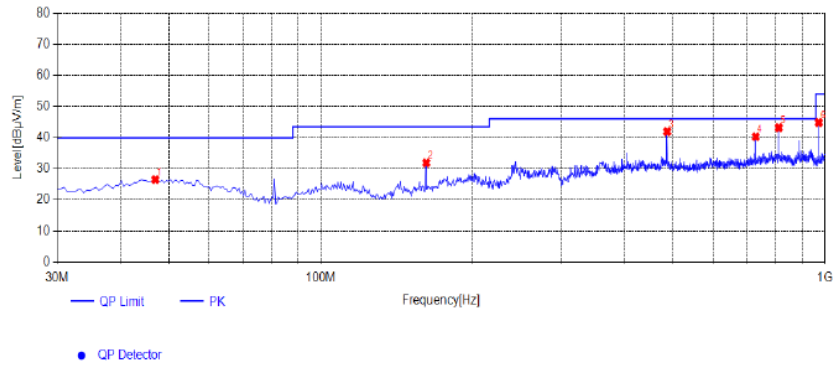

Suspected List											
NO.	Frequency [MHz]	Reading [dBµV/m]	Factor [dB]	Result [dBµV/m]	Limit [dBµV/m]	Margin [dB]	Height [cm]	Angle [°]	Detector	Polarity	Remark
1	46.975	37.45	-10.93	26.52	40.00	13.48	100	119	PK	Horizontal	PASS
2	161.92	46.77	-14.87	31.90	43.50	11.60	100	128	PK	Horizontal	PASS
3	486.385	44.98	-3.03	41.95	46.00	4.05	100	119	PK	Horizontal	PASS
4	729.37	40.18	0.12	40.30	46.00	5.70	100	328	PK	Horizontal	PASS
5	810.365	41.19	2.02	43.21	46.00	2.79	100	338	PK	Horizontal	PASS
6	972.355	40.57	4.27	44.84	54.00	9.16	100	295	PK	Horizontal	PASS

Note: 1. Result (dBµV/m) = Reading(dBµV/m) + Factor (dB) .

2. Factor (dB) = Antenna Factor (dB/m) + Cable loss (dB) - Pre Amplifier gain (dB).

**Vertical**

Test Graph

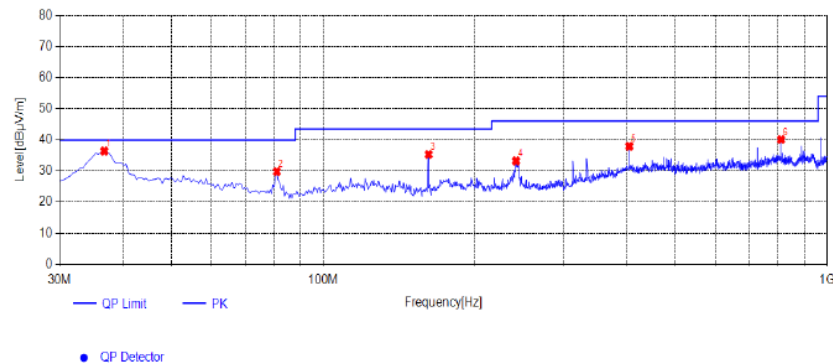

Suspected List											
NO.	Frequency [MHz]	Reading [dBµV/m]	Factor [dB]	Result [dBµV/m]	Limit [dBµV/m]	Margin [dB]	Height [cm]	Angle [°]	Detector	Polarity	Remark
1	36.79	50.48	-14.12	36.36	40.00	3.64	100	116	PK	Vertical	PASS
2	80.925	46.77	-16.95	29.82	40.00	10.18	100	308	PK	Vertical	PASS
3	161.92	50.14	-14.87	35.27	43.50	8.23	100	69	PK	Vertical	PASS
4	241.46	44.38	-11.17	33.21	46.00	12.79	100	238	PK	Vertical	PASS
5	404.905	41.37	-3.48	37.89	46.00	8.11	100	298	PK	Vertical	PASS
6	810.365	38.08	2.02	40.10	46.00	5.90	100	232	PK	Vertical	PASS

Note: 1. Result (dBµV/m) = Reading(dBµV/m) + Factor (dB) .

2. Factor (dB) = Antenna Factor (dB/m) + Cable loss (dB) - Pre Amplifier gain (dB).

Adapter: SOY-2400150-332-A

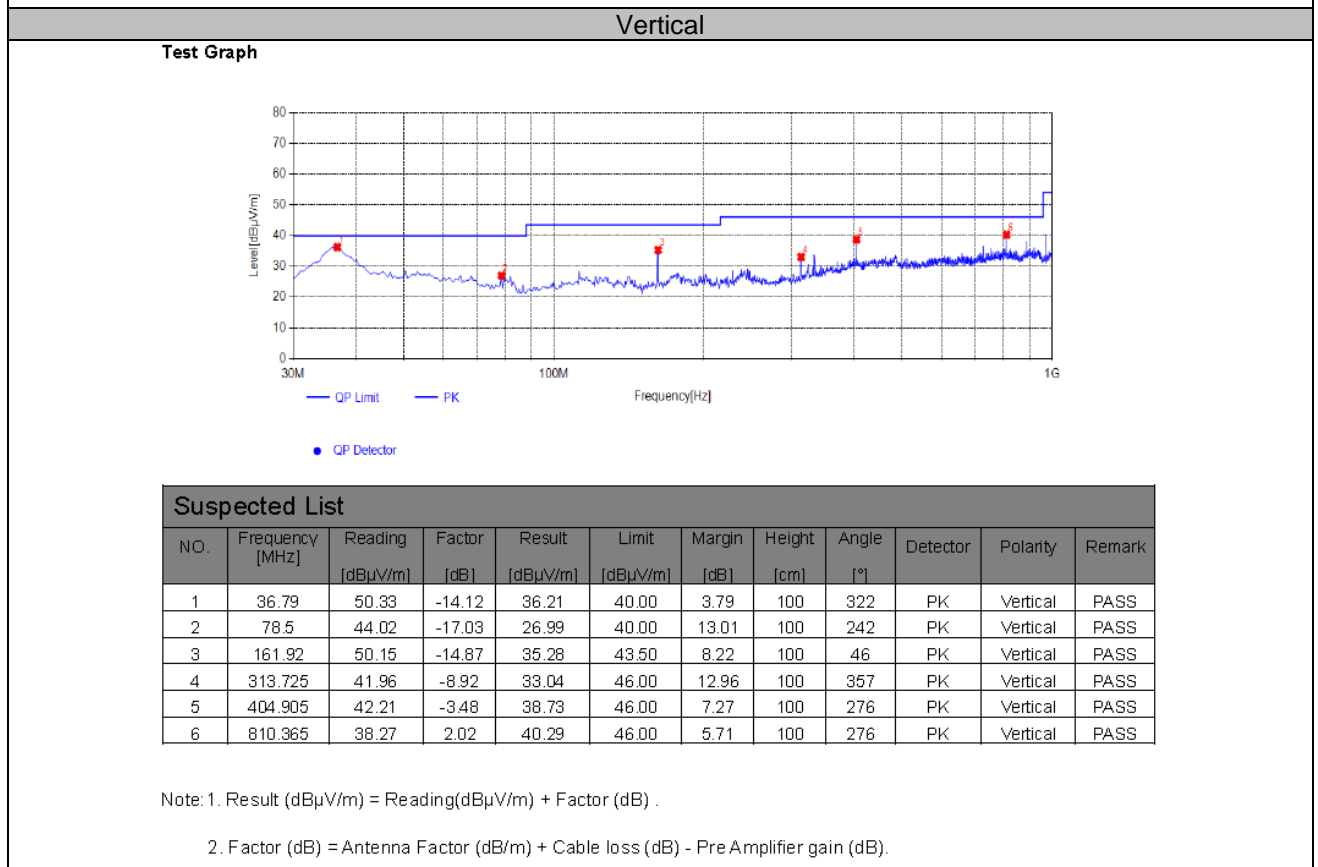
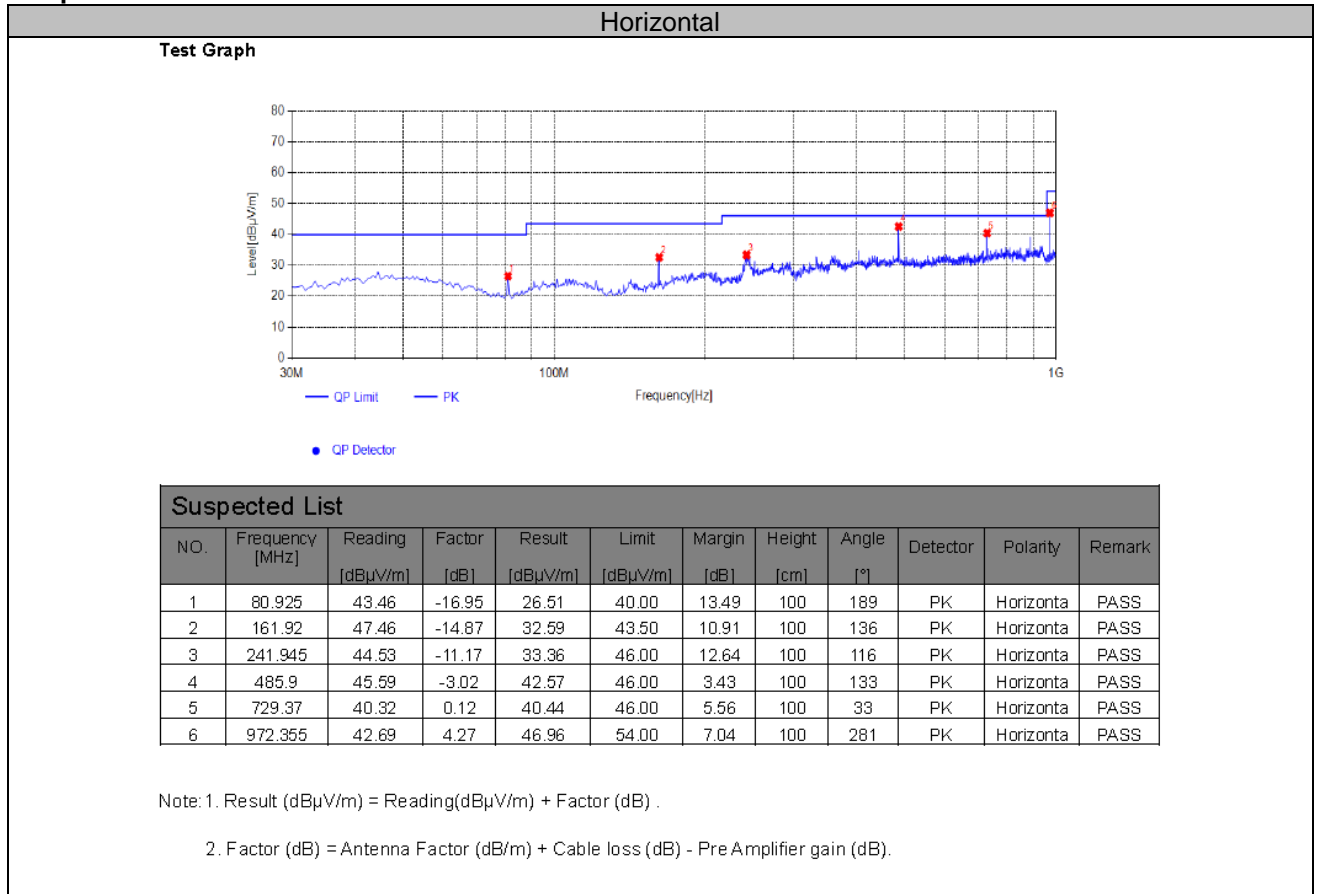

Adapter: CYZS36-240150

**Horizontal**

**Test Graph**

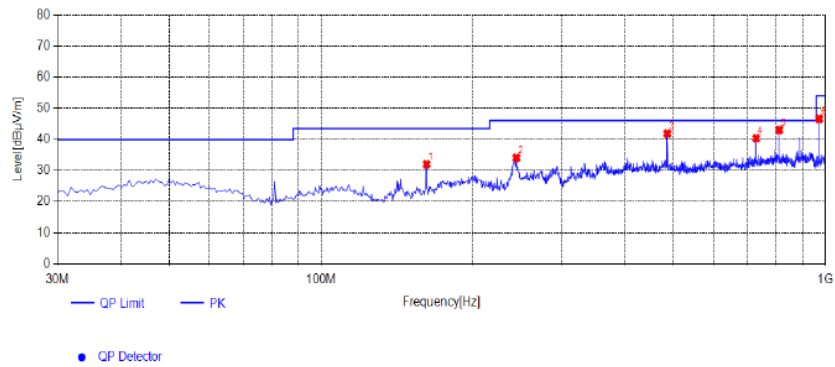

Suspected List											
NO.	Frequency [MHz]	Reading [dBµV/m]	Factor [dB]	Result [dBµV/m]	Limit [dBµV/m]	Margin [dB]	Height [cm]	Angle [°]	Detector	Polarity	Remark
1	161.92	46.87	-14.87	32.00	43.50	11.50	100	122	PK	Horizontal	PASS
2	243.885	45.13	-11.06	34.07	46.00	11.93	100	108	PK	Horizontal	PASS
3	485.9	44.90	-3.02	41.88	46.00	4.12	100	115	PK	Horizontal	PASS
4	729.37	40.26	0.12	40.38	46.00	5.62	100	36	PK	Horizontal	PASS
5	810.365	41.02	2.02	43.04	46.00	2.96	100	331	PK	Horizontal	PASS
6	972.355	42.32	4.27	46.59	54.00	7.41	100	288	PK	Horizontal	PASS

Note 1. Result (dBµV/m) = Reading(dBµV/m) + Factor (dB) .

2. Factor (dB) = Antenna Factor (dB/m) + Cable loss (dB) - Pre Amplifier gain (dB).

**Vertical**

**Test Graph**

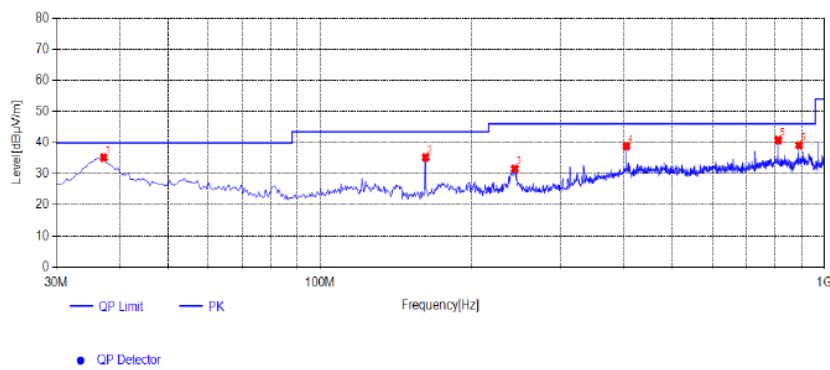

Suspected List											
NO.	Frequency [MHz]	Reading [dBµV/m]	Factor [dB]	Result [dBµV/m]	Limit [dBµV/m]	Margin [dB]	Height [cm]	Angle [°]	Detector	Polarity	Remark
1	37.275	49.12	-13.98	35.14	40.00	4.86	100	337	PK	Vertical	PASS
2	161.92	50.07	-14.87	35.20	43.50	8.30	100	59	PK	Vertical	PASS
3	243.4	42.73	-11.10	31.63	46.00	14.37	100	221	PK	Vertical	PASS
4	404.905	42.35	-3.48	38.87	46.00	7.13	100	271	PK	Vertical	PASS
5	810.365	38.84	2.02	40.86	46.00	5.14	100	235	PK	Vertical	PASS
6	891.36	36.71	2.46	39.17	46.00	6.83	100	3	PK	Vertical	PASS

Note 1. Result (dBµV/m) = Reading(dBµV/m) + Factor (dB) .

2. Factor (dB) = Antenna Factor (dB/m) + Cable loss (dB) - Pre Amplifier gain (dB).

## For 1GHz to 25GHz

## GFSK /Channel 0 / 2402 MHz(Worst Case)

Freq. MHz	Reading dBuV	Ant. Fac. dB/m	Pre. Fac. dB	Cab. Loss dB	Measured dBuV/m	Limit dBuV/m	Margin dB	Remark	Pol.
4804.00	50.60	32.44	30.25	7.95	60.74	74.00	-13.26	Peak	Horizontal
4804.00	35.34	32.44	30.25	7.95	45.48	54.00	-8.52	Average	Horizontal
4804.00	52.99	32.44	30.25	7.95	63.13	74.00	-10.87	Peak	Vertical
4804.00	34.44	32.44	30.25	7.95	44.58	54.00	-9.42	Average	Vertical

## Channel 39 / 2441 MHz

Freq. MHz	Reading dBuV	Ant. Fac. dB/m	Pre. Fac. dB	Cab. Loss dB	Measured dBuV/m	Limit dBuV/m	Margin dB	Remark	Pol.
4882.00	50.64	32.52	30.31	8.12	60.97	74.00	-13.03	Peak	Horizontal
4882.00	36.63	32.52	30.31	8.12	46.96	54.00	-7.04	Average	Horizontal
4882.00	51.42	32.52	30.31	8.12	61.75	74.00	-12.25	Peak	Vertical
4882.00	35.77	32.52	30.31	8.12	46.10	54.00	-7.90	Average	Vertical

## Channel 78 / 2480 MHz

Freq. MHz	Reading dBuV	Ant. Fac. dB/m	Pre. Fac. dB	Cab. Loss dB	Measured dBuV/m	Limit dBuV/m	Margin dB	Remark	Pol.
4960.00	51.83	32.68	30.27	7.88	62.12	74.00	-11.88	Peak	Horizontal
4960.00	36.84	32.68	30.27	7.88	47.13	54.00	-6.87	Average	Horizontal
4960.00	48.59	32.68	30.27	7.88	58.88	74.00	-15.12	Peak	Vertical
4960.00	30.86	32.68	30.27	7.88	41.15	54.00	-12.85	Average	Vertical

## Notes:

- 1). Measuring frequencies from 9 KHz~10<sup>th</sup> harmonic or 26.5GHz (which is less), No emission found between lowest internal used/generated frequency to 30MHz.
- 2). Radiated emissions measured in frequency range from 9 KHz~10<sup>th</sup> harmonic or 26.5GHz (which is less) were made with an instrument using Peak detector mode.
- 3). Data of measurement within this frequency range shown " --- " in the table above means the reading of emissions are attenuated more than 20dB below the permissible limits or the field strength is too small to be measured.
- 4). Measured= Reading- Pre. Fac.+ Ant. Fac.+ Cab. Loss
- 5). Margin = Measured- Limit

**NOTE: All the modes have been tested and recorded worst mode in the report(Version A\_Adapter: ADS-65HI-19A-124036E).**

### 4.3. Maximum Peak Output Power

#### TEST CONFIGURATION

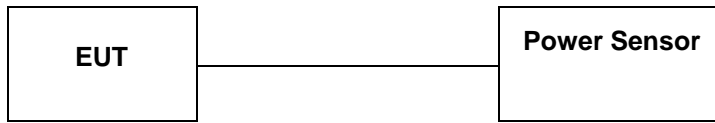

#### TEST PROCEDURE

According to ANSI C63.10:2013 Maximum peak conducted output power for HFSS devices:  
The maximum peak conducted output power may be measured using a broadband peak RF power meter. The power meter shall have a video bandwidth that is greater than or equal to the HFSS bandwidth and shall utilize a fast-responding diode detector.  
The maximum Average conducted output power may be measured using a wideband RF power meter with a thermocouple detector or equivalent. The power meter shall have a video bandwidth that is greater than or equal to the HFSS bandwidth and shall utilize a fast-responding diode detector.

#### LIMIT

For frequency hopping systems operating in the 2400–2483.5 MHz band employing at least 75 non-overlapping hopping channels, and all frequency hopping systems in the 5725–5850 MHz band: 1 watt. For all other frequency hopping systems in the 2400–2483.5 MHz band: 0.125 watts.

#### TEST RESULTS

For reporting purpose only.

Please refer to Appendix A.3.

#### 4.4. 99% and 20dB Bandwidth

##### TEST CONFIGURATION

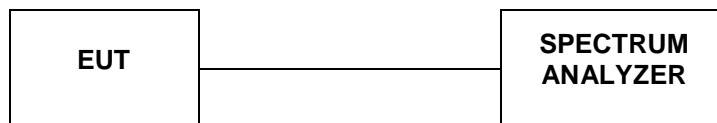

##### TEST PROCEDURE

The transmitter output was connected to the spectrum analyzer through an attenuator. The bandwidth of the fundamental frequency was measured by spectrum analyzer with RBW=30KHz and VBW=100KHz. The 20dB bandwidth is defined as the total spectrum the power of which is higher than peak power minus 20dB.

##### LIMIT

For frequency hopping systems operating in the 2400MHz-2483.5MHz no limit for 20dB bandwidth.

##### TEST RESULTS

For reporting purpose only.

Please refer to Appendix A.1.

Please refer to Appendix A.2.

## 4.5. Frequency Separation

### TEST CONFIGURATION

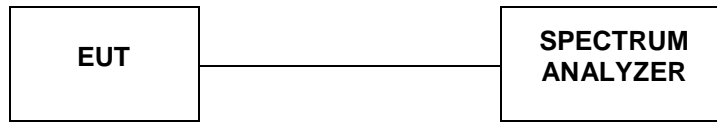

### TEST PROCEDURE

The transmitter output was connected to the spectrum analyzer through an attenuator. The bandwidth of the fundamental frequency was measured by spectrum analyzer with RBW=100KHz and VBW=300KHz.

### LIMIT

According to 15.247(a)(1), frequency hopping systems shall have hopping channel carrier frequencies separated by minimum of 25KHz or the  $\frac{2}{3} \times 20\text{dB}$  bandwidth of the hopping channel, whichever is greater.

### TEST RESULTS

For reporting purpose only.

Please refer to Appendix A.4.

### 4.6. Conducted Spurious Emissions and Band Edge Compliance of RF Emission

#### TEST REQUIREMENT

In any 100 kHz bandwidth outside the frequency band in which the spread spectrum or digitally modulated intentional radiator is operating, the radio frequency power that is produced by the intentional radiator shall be at least 20 dB below that in the 100 kHz bandwidth within the band that contains the highest level of the desired power, based on either an RF conducted or a radiated measurement, provided the transmitter demonstrates compliance with the peak conducted power limits. If the transmitter complies with the conducted power limits based on the use of RMS averaging over a time interval, as permitted under paragraph (b)(3) of this section, the attenuation required under this paragraph shall be 30 dB instead of 20 dB. Attenuation below the general limits specified in §15.209(a) is not required. In addition, radiated emissions which fall in the restricted bands, as defined in §15.205(a), must also comply with the radiated emission limits specified in §15.209(a) (see §15.205(c)).

#### TEST CONFIGURATION

For Radiated

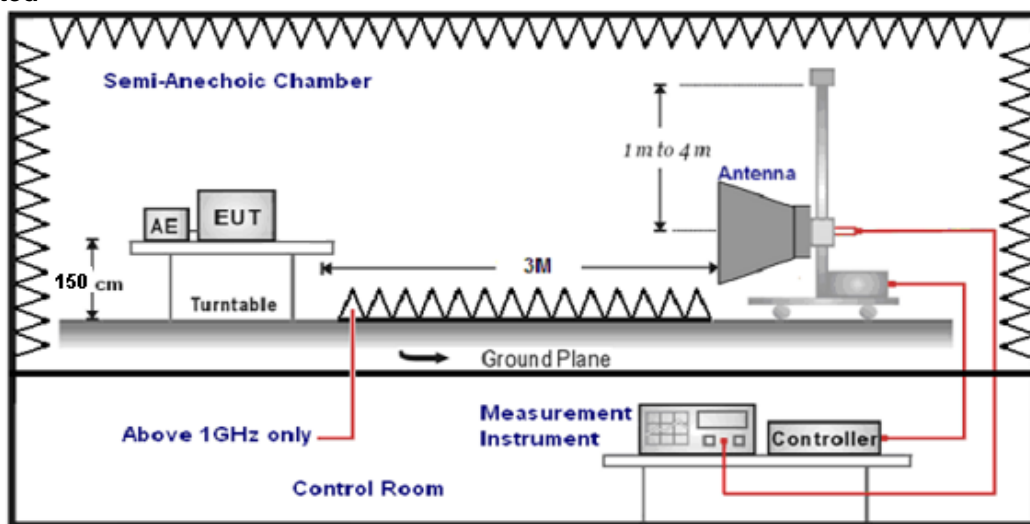

For Conducted

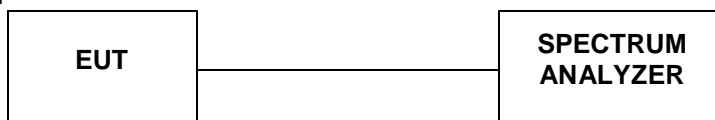

#### TEST PROCEDURE

1. The EUT was placed on a turn table which is 1.5m above ground plane.
2. Maximum procedure was performed by raising the receiving antenna from 1m to 4m and rotating the turn table from 0° to 360° to acquire the highest emissions from EUT.
3. And also, each emission was to be maximized by changing the polarization of receiving antenna both horizontal and vertical.
4. Repeat above procedures until all frequency measurements have been completed..
5. The distance between test antenna and EUT was 3 meter:
6. Setting test receiver/spectrum as following table states:

Test Frequency range	Test Receiver/Spectrum Setting	Detector
1GHz-40GHz	Peak Value: RBW=1MHz/VBW=3MHz, Sweep time=Auto Average Value: RBW=1MHz/VBW=10Hz, Sweep time=Auto	Peak

#### LIMIT

Below -20dB of the highest emission level in operating band.

Radiated emissions which fall in the restricted bands, as defined in § 15.205(a), must also comply with the radiated emission limits specified in § 15.209(a)



**TEST RESULTS**

Remark: we measured all conditions(DH1,DH3,DH5) and recorded worst case at DH1.

**4.6.1 For Radiated Bandedge Measurement**

Remark: we tested radiated bandedge at both hopping and no-hopping modes,recorded worst case at no-hopping mode

Temperature	23.8°C	Humidity	53.7%
Test Engineer	Evan Ouyang	Configurations	BT

**GFSK**

Frequency(MHz):			2402			Polarity:			HORIZONTAL		
Frequency (MHz)	Emission Level (dBuV/m)		Limit (dBuV/m)	Margin (dB)	Antenna Height (m)	Table Angle (Degree)	Raw Value (dBuV)	Antenna Factor (dB/m)	Cable Factor (dB)	Pre-amplifier	Correction Factor (dB/m)
2390.00	46.97	PK	74.00	-27.03	1.50	73	52.28	27.49	3.32	36.12	-5.31
2390.00	34.42	AV	54.00	-19.58	1.50	73	39.73	27.49	3.32	36.12	-5.31
Frequency(MHz):			2402			Polarity:			VERTICAL		
Frequency (MHz)	Emission Level (dBuV/m)		Limit (dBuV/m)	Margin (dB)	Antenna Height (m)	Table Angle (Degree)	Raw Value (dBuV)	Antenna Factor (dB/m)	Cable Factor (dB)	Pre-amplifier	Correction Factor (dB/m)
2390.00	49.03	PK	74.00	-24.97	1.50	265	54.34	27.49	3.32	36.12	-5.31
2390.00	31.34	AV	54.00	-22.66	1.50	265	36.65	27.49	3.32	36.12	-5.31
Frequency(MHz):			2480			Polarity:			HORIZONTAL		
Frequency (MHz)	Emission Level (dBuV/m)		Limit (dBuV/m)	Margin (dB)	Antenna Height (m)	Table Angle (Degree)	Raw Value (dBuV)	Antenna Factor (dB/m)	Cable Factor (dB)	Pre-amplifier	Correction Factor (dB/m)
2483.50	46.03	PK	74.00	-27.97	1.50	173	51.75	27.45	3.38	36.55	-5.72
2483.50	33.56	AV	54.00	-20.44	1.50	173	39.28	27.45	3.38	36.55	-5.72
Frequency(MHz):			2480			Polarity:			VERTICAL		
Frequency (MHz)	Emission Level (dBuV/m)		Limit (dBuV/m)	Margin (dB)	Antenna Height (m)	Table Angle (Degree)	Raw Value (dBuV)	Antenna Factor (dB/m)	Cable Factor (dB)	Pre-amplifier	Correction Factor (dB/m)
2483.50	48.80	PK	74.00	-25.20	1.50	136	54.52	27.45	3.38	36.55	-5.72
2483.50	29.53	AV	54.00	-24.47	1.50	136	35.25	27.45	3.38	36.55	-5.72

**REMARKS:**

1. Emission level (dBuV/m) =Raw Value (dBuV)+Correction Factor (dB/m)
2. Correction Factor (dB/m) = Antenna Factor (dB/m)+Cable Factor (dB)-Pre-amplifier Factor
3. Margin value = Limit value- Emission level.
4. -- Mean the PK detector measured value is below average limit.
5. The other emission levels were very low against the limit.

**NOTE: All the modes have been tested and recorded worst mode in the report(Version A\_Adapter: ADS-65HI-19A-124036E).**

**4.6.2 For Conducted Bandedge Measurement**

For reporting purpose only.

Please refer to Appendix A.7.

**4.6.3 For Conducted Spurious Emissions Measurement**

For reporting purpose only.

Please refer to Appendix A.8.

#### 4.7. Number of hopping frequency

##### TEST CONFIGURATION

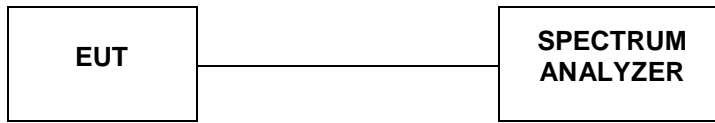

##### TEST PROCEDURE

The transmitter output was connected to the spectrum analyzer through an attenuator. Set spectrum analyzer start 2400MHz to 2483.5MHz with RBW=100KHz and VBW=300KHz.

##### LIMIT

Frequency hopping systems in the 2400–2483.5MHz band shall use at least 15 channels.

##### TEST RESULTS

For reporting purpose only.

Please refer to Appendix A.6.

#### 4.8. Time Of Occupancy(Dwell Time)

##### TEST CONFIGURATION

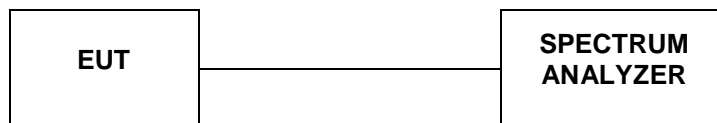

##### TEST PROCEDURE

The transmitter output was connected to the spectrum analyzer through an attenuator. Set center frequency of spectrum analyzer=operating frequency with RBW=1MHz and VBW=3MHz,Span=0Hz.

##### LIMIT

The average time of occupancy on any channel shall not be greater than 0.4 seconds within a period of 0.4 seconds multiplied by the number of hopping channels employed.

##### TEST RESULTS

For reporting purpose only.

Please refer to Appendix A.5.

### 4.9. Pseudorandom Frequency Hopping Sequence

**TEST APPLICABLE**

**For 47 CFR Part 15C section 15.247 (a)(1) requirement:**

Frequency hopping systems shall have hopping channel carrier frequencies separated by a minimum of 25 kHz or the 20 dB bandwidth of the hopping channel, whichever is greater. Alternatively, frequency hopping systems operating in the 2400–2483.5 MHz band may have hopping channel carrier frequencies that are separated by 25 kHz or two-thirds of the 20 dB bandwidth of the hopping channel, whichever is greater, provided the systems operate with an output power no greater than 125 mW. The system shall hop to channel frequencies that are selected at the system hopping rate from a pseudo randomly ordered list of hopping frequencies. Each frequency must be used equally on the average by each transmitter. The system receivers shall have input bandwidths that match the hopping channel bandwidths of their corresponding transmitters and shall shift frequencies in synchronization with the transmitted signals.

**EUT Pseudorandom Frequency Hopping Sequence Requirement**

The pseudorandom frequency hopping sequence may be generated in a nine-stage shift register whose 5<sup>th</sup> and 9<sup>th</sup> stage outputs are added in a modulo-two addition stage. And the result is fed back to the input of the first stage. The sequence begins with the first one of 9 consecutive ones, for example: the shift register is initialized with nine ones.

- Number of shift register stages:9
- Length of pseudo-random sequence:29-1=511 bits
- Longest sequence of zeros:8(non-inverted signal)

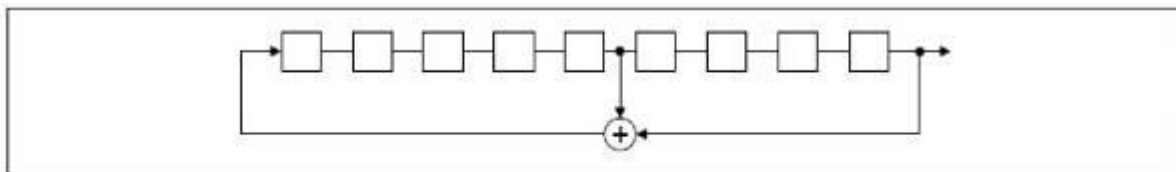

*Linear Feedback Shift Register for Generation of the PRBS sequence*

An example of pseudorandom frequency hopping sequence as follows:

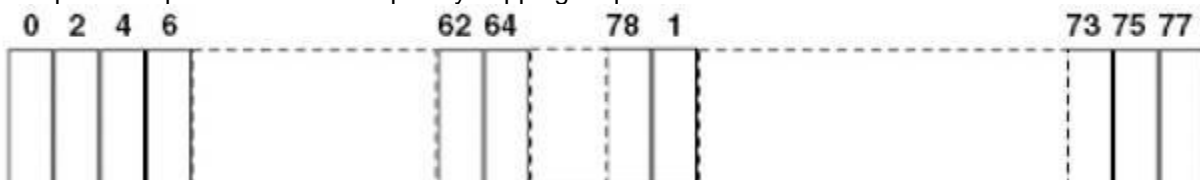

Each frequency used equally on the average by each transmitter. The system receiver have input bandwidths that match the hopping channel bandwidths of their corresponding transmitter and shift frequencies in synchronization with the transmitted signals.

#### **4.10. Antenna Requirement**

##### **Standard Applicable**

For intentional device, according to FCC 47 CFR Section 15.203, an intentional radiator shall be designed to ensure that no antenna other than that furnished by the responsible party shall be used with the device.

And according to FCC 47 CFR Section 15.247 (c), if transmitting antennas of directional gain greater than 6dBi are used, the power shall be reduced by the amount in dB that the directional gain of the antenna exceeds 6dBi.

##### **Test Result**

The antenna used for this product is Internal Antenna and that no antenna other than that furnished by the responsible party shall be used with the device, the maximum peak gain of the transmit antenna is only 3.66dBi.

Reference to the **External photos**.

## 5. TEST SETUP PHOTOS OF THE EUT

Photo of Radiated Emissions Measurement



Fig. 1



Fig. 2

Photo of Conducted Emission Measurement



Fig. 3

## 6. EXTERNAL AND INTERNAL PHOTOS OF THE EUT

### 6.1. External photos of the EUT



Fig. 1



Fig. 2



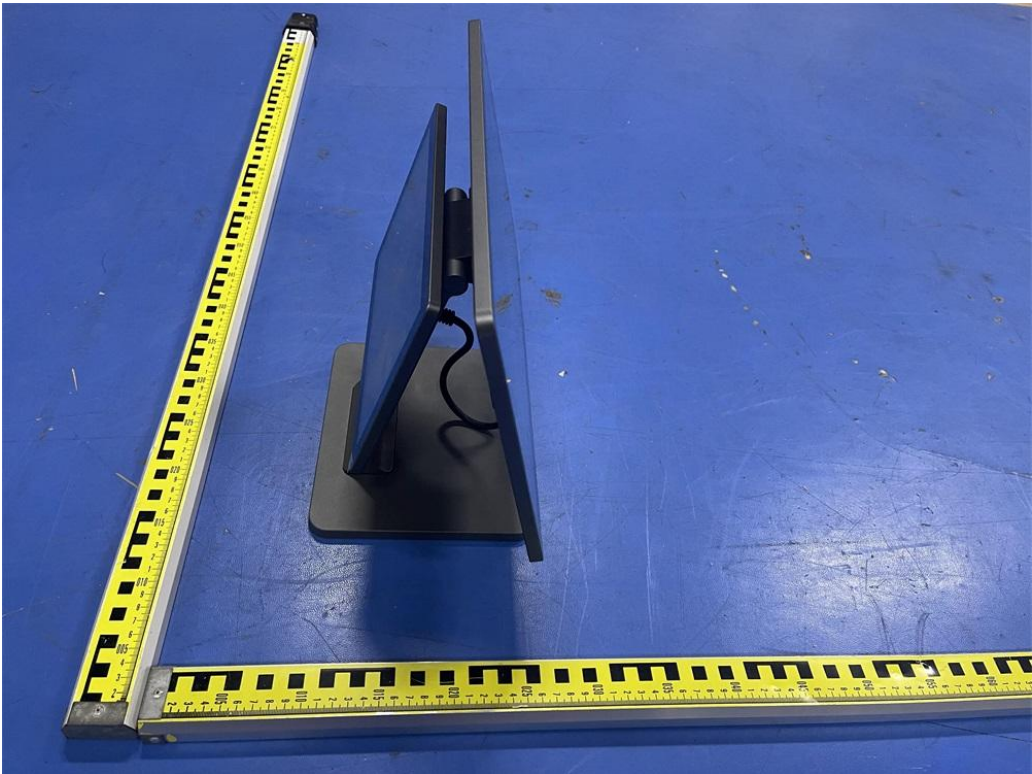

Fig. 3



Fig. 4



Fig. 5

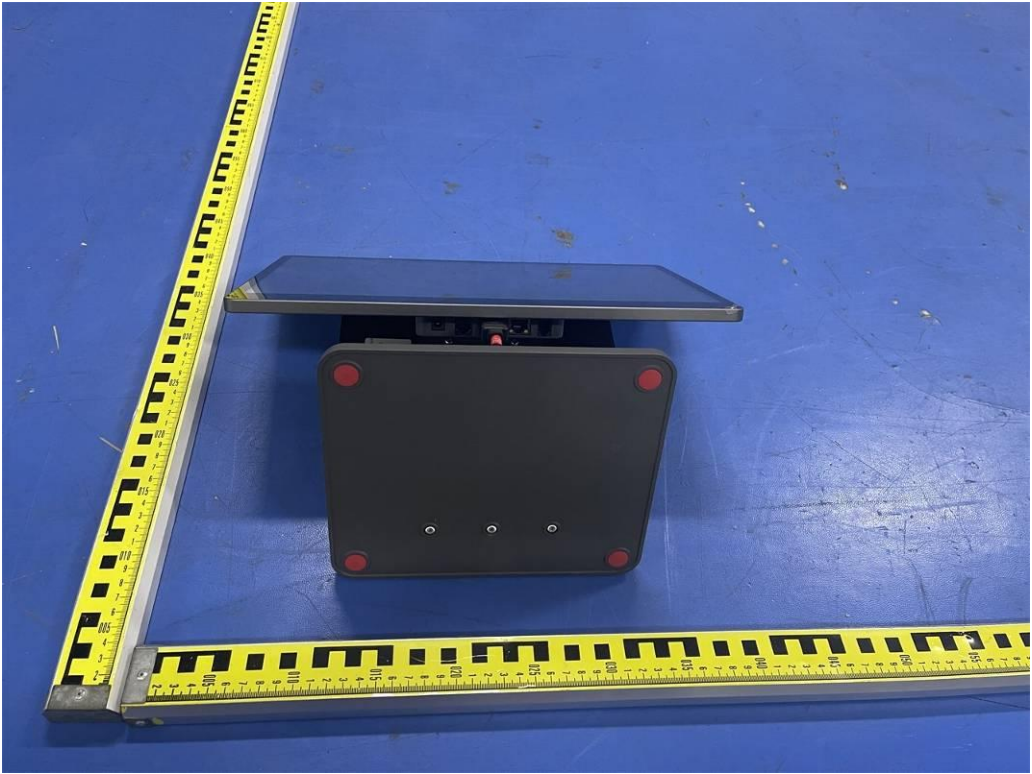

Fig. 6

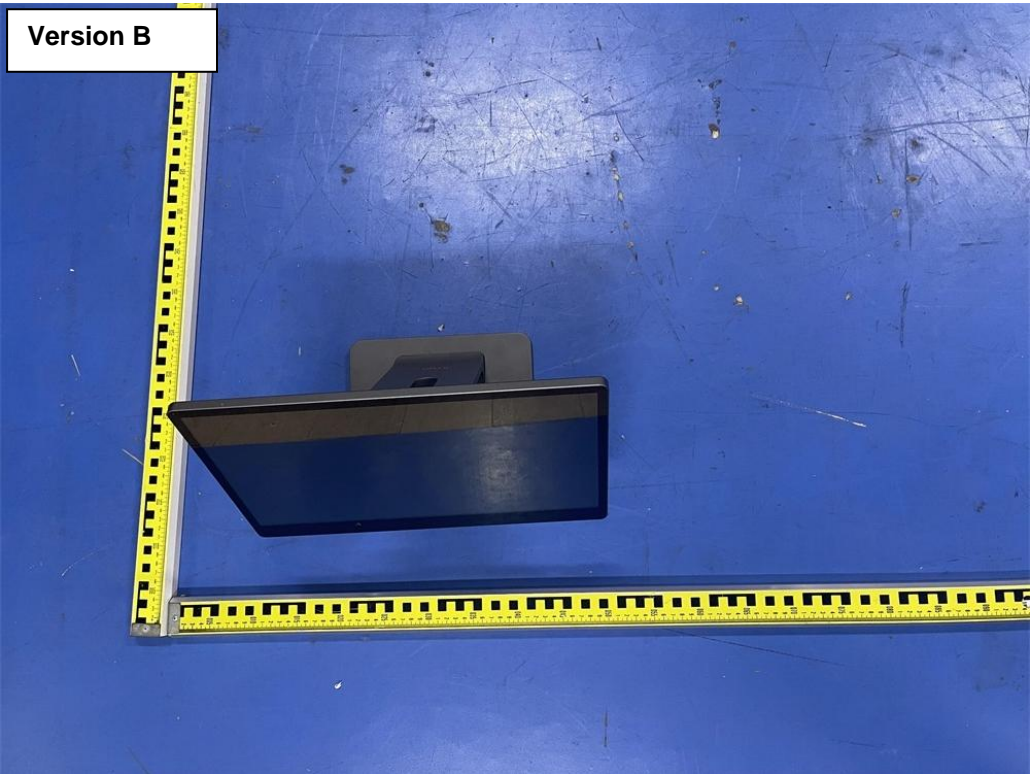

Fig. 7

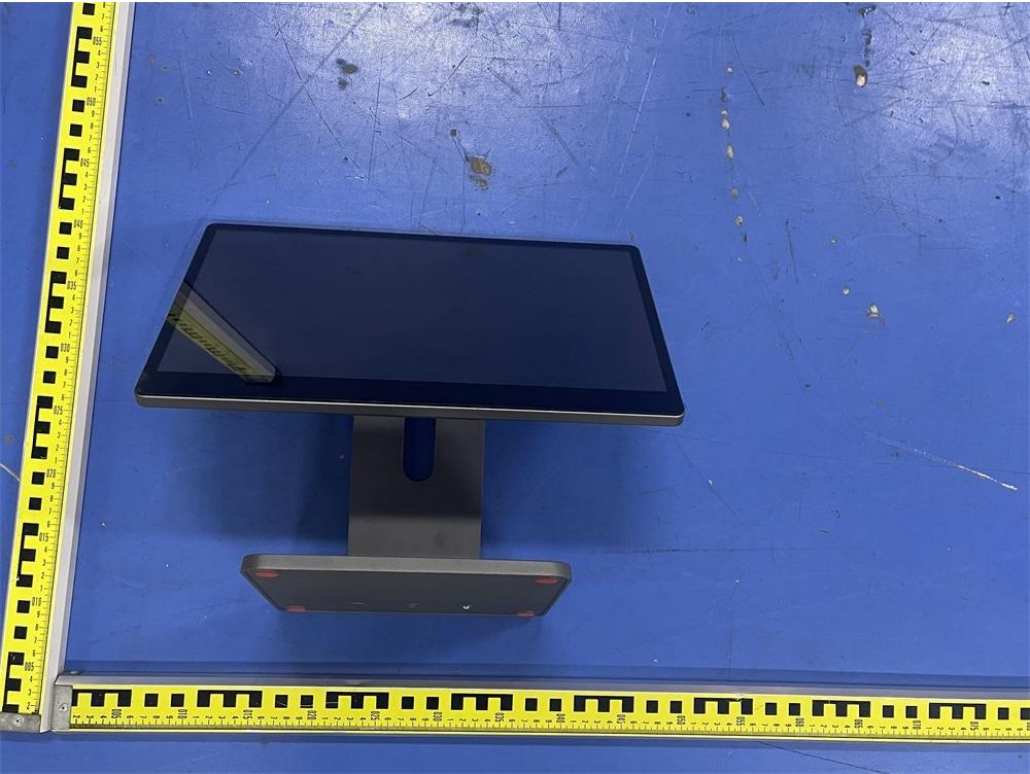

Fig. 8



Fig. 9



Fig. 10

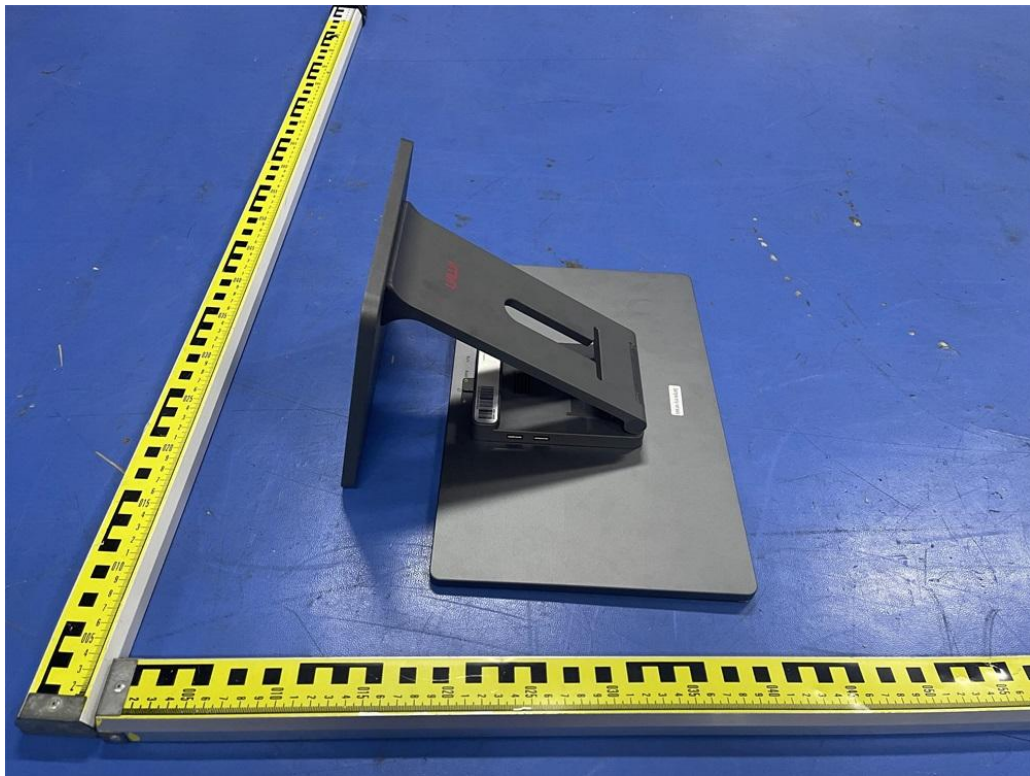

Fig. 11

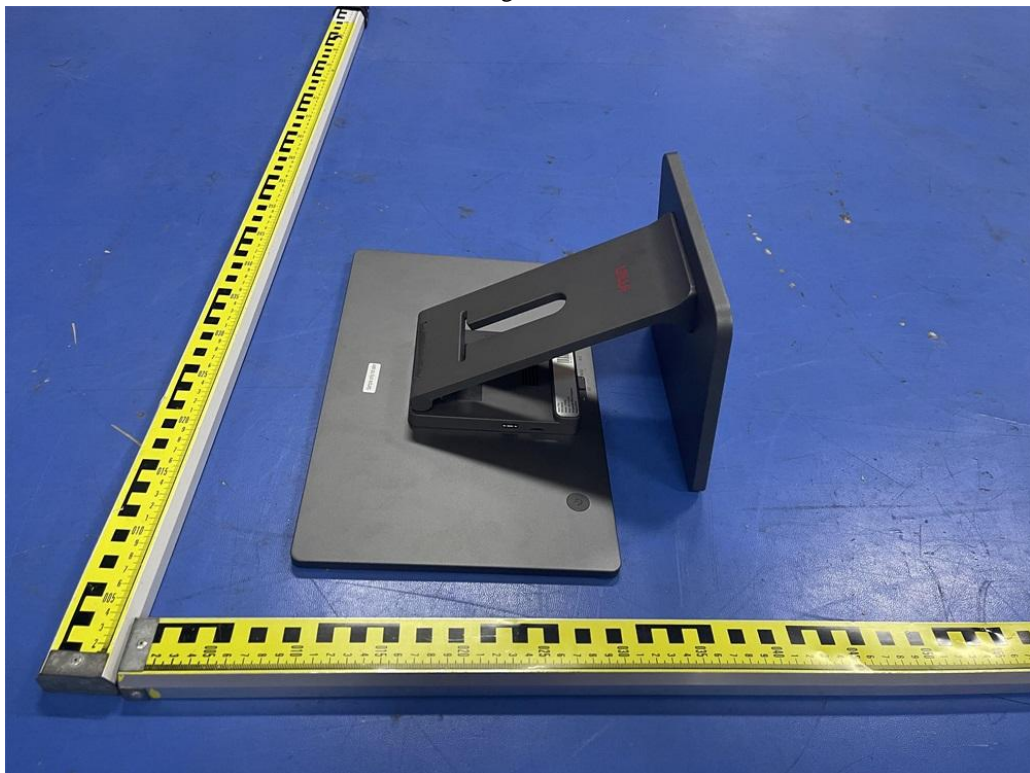

Fig. 12



Fig. 13



Fig. 14



Fig. 15



Fig. 16



Fig. 17



Fig. 18





Fig. 19

## 6.2. Internal photos of the EUT

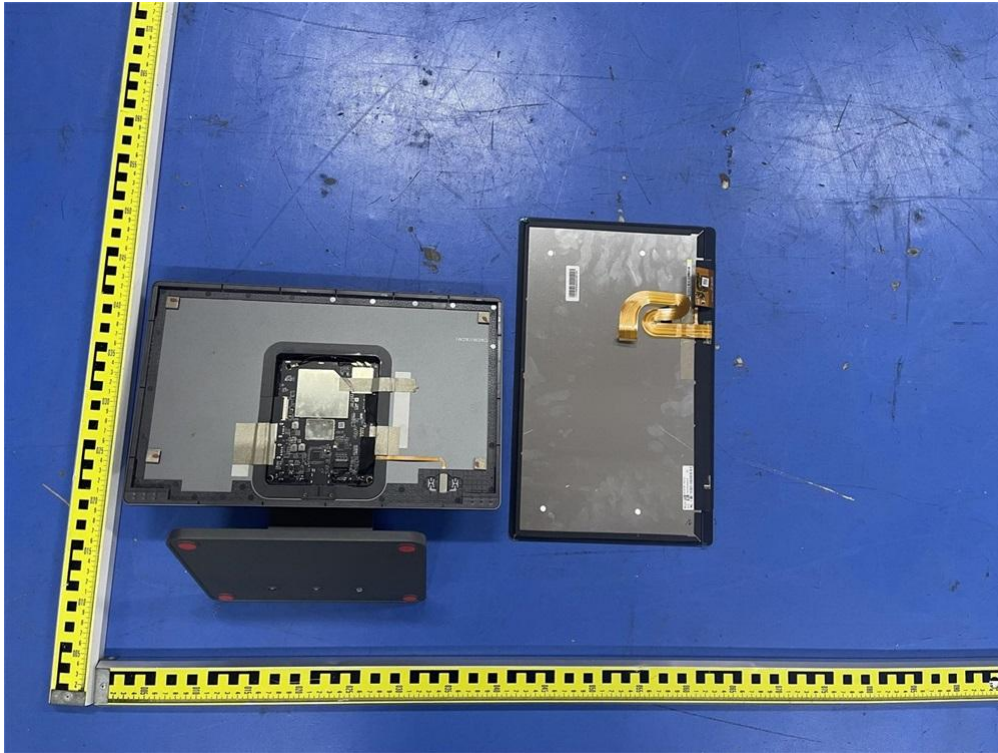

Fig. 20

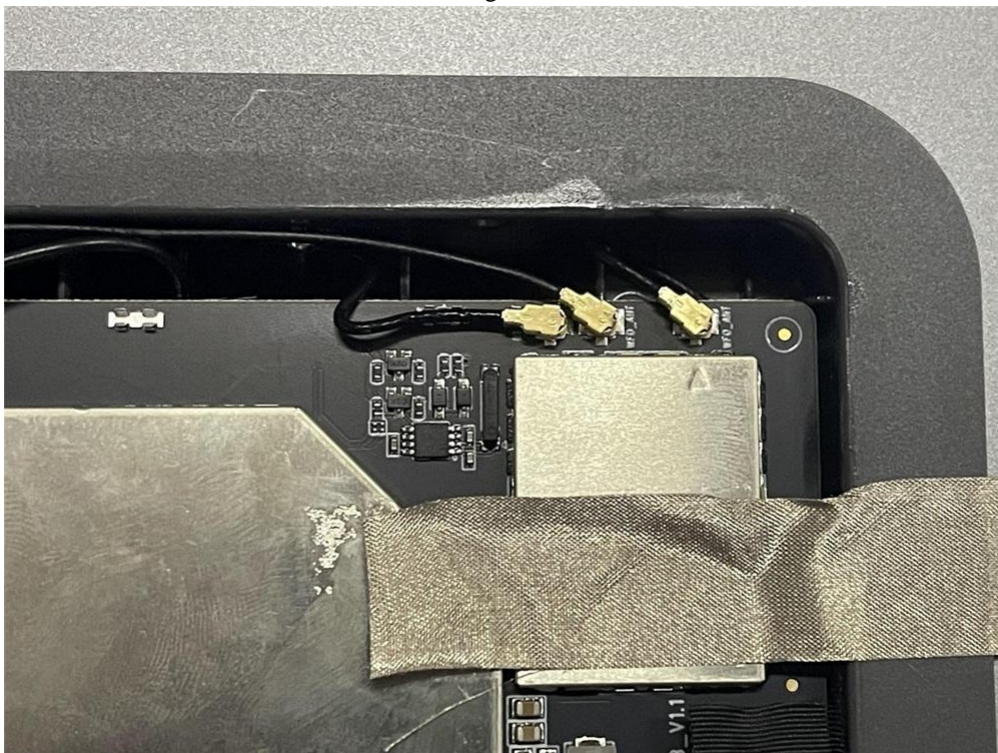

Fig. 21

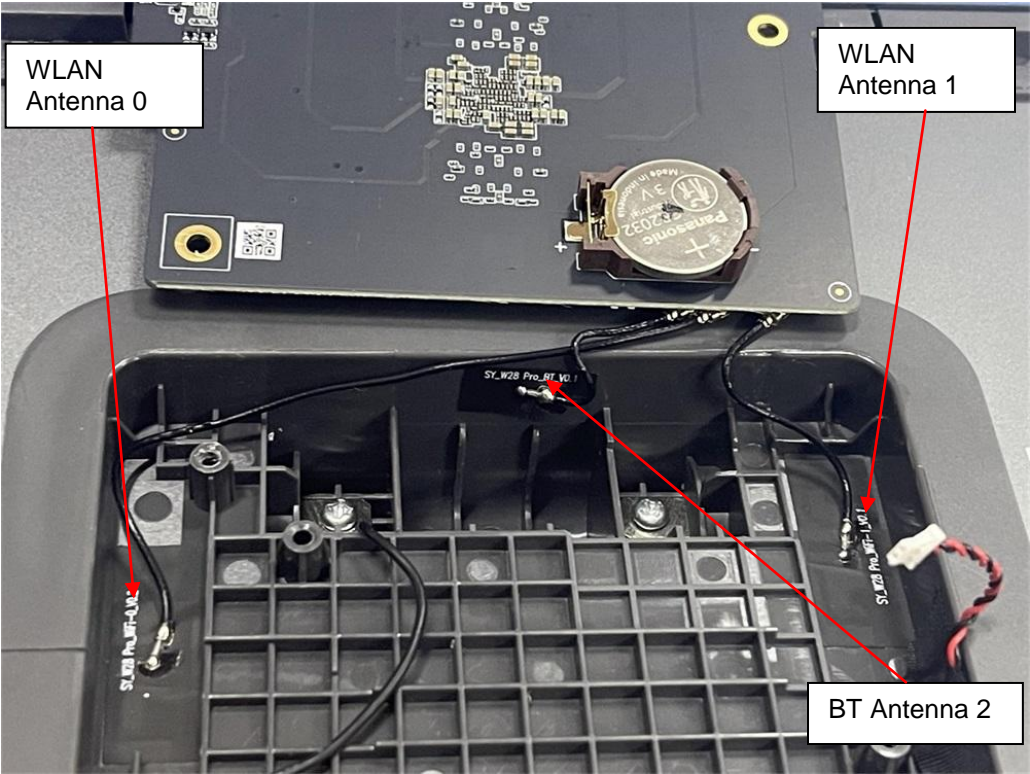

Fig. 22

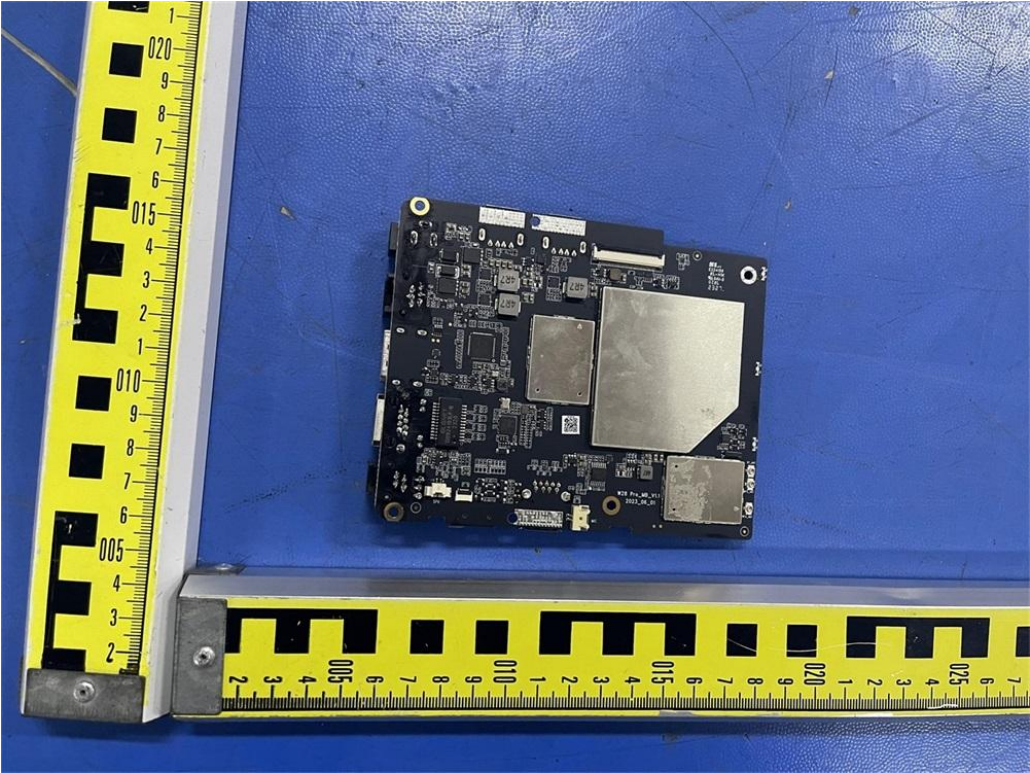

Fig. 23

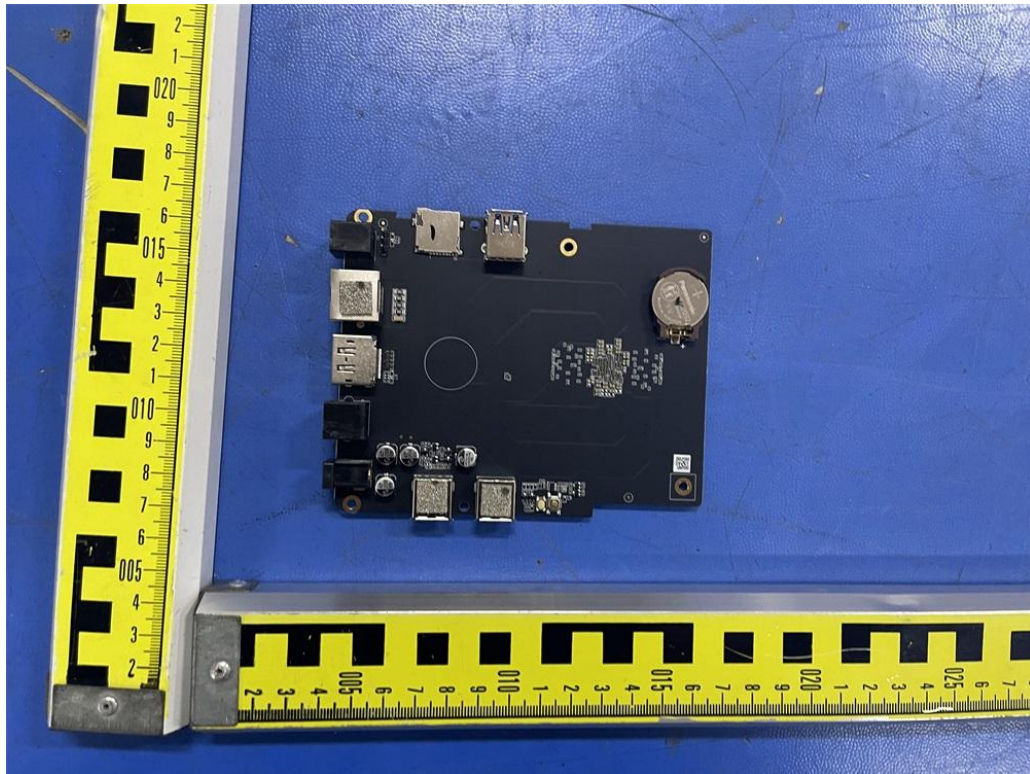

Fig. 24

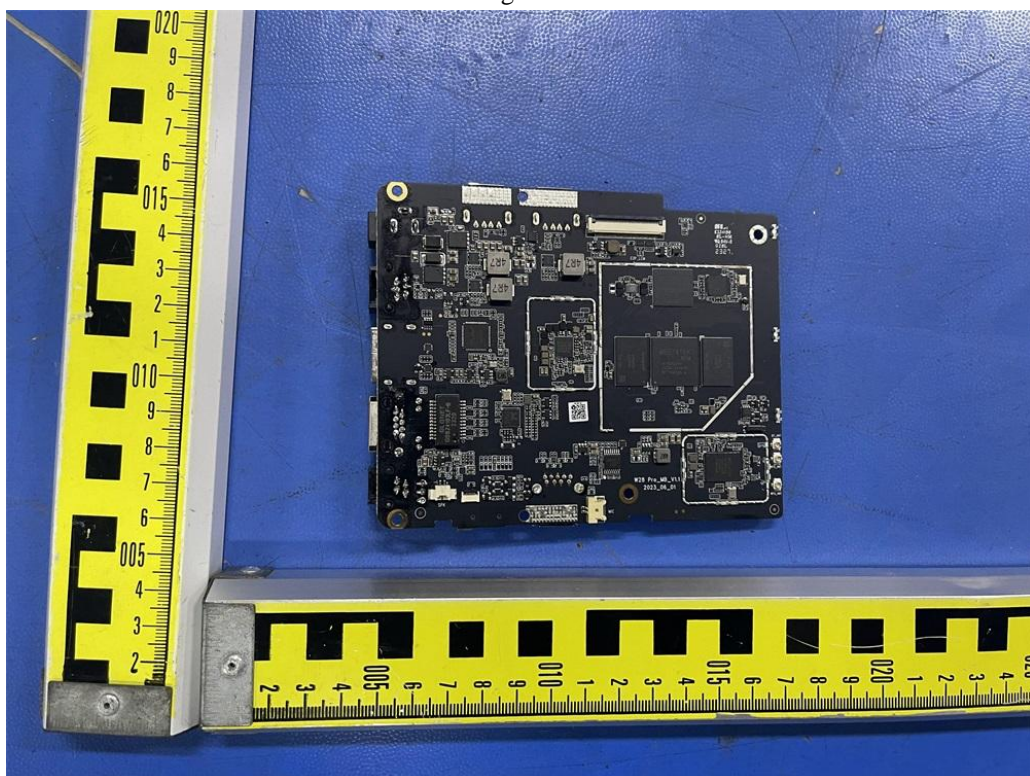

Fig. 25

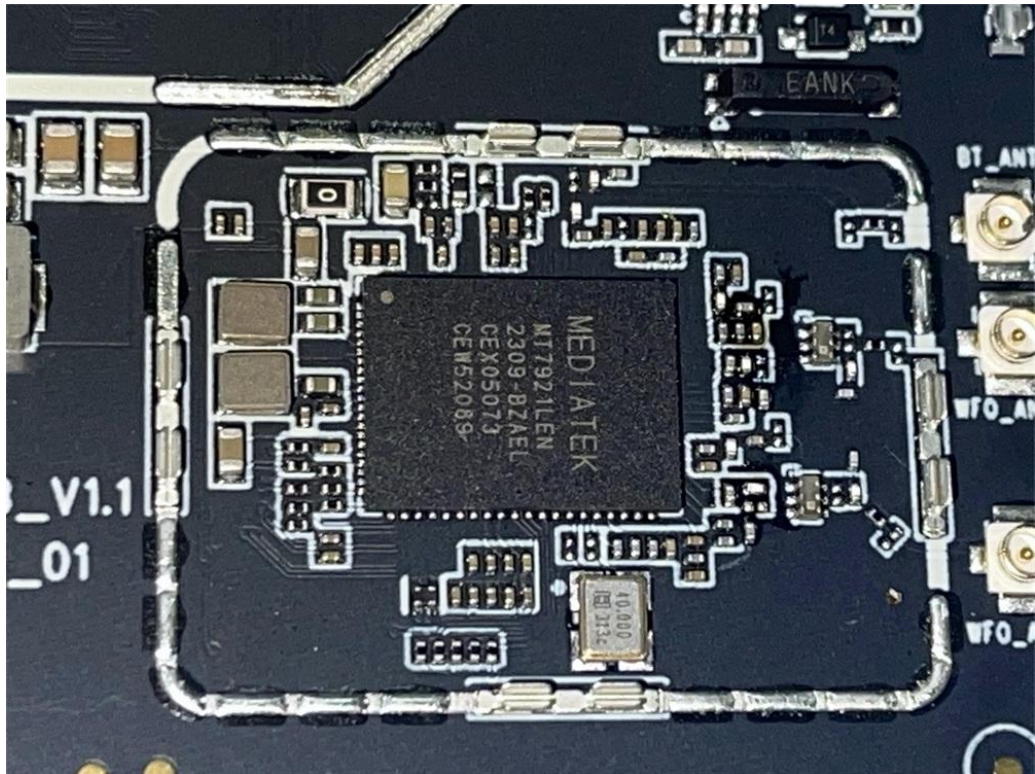

Fig. 26

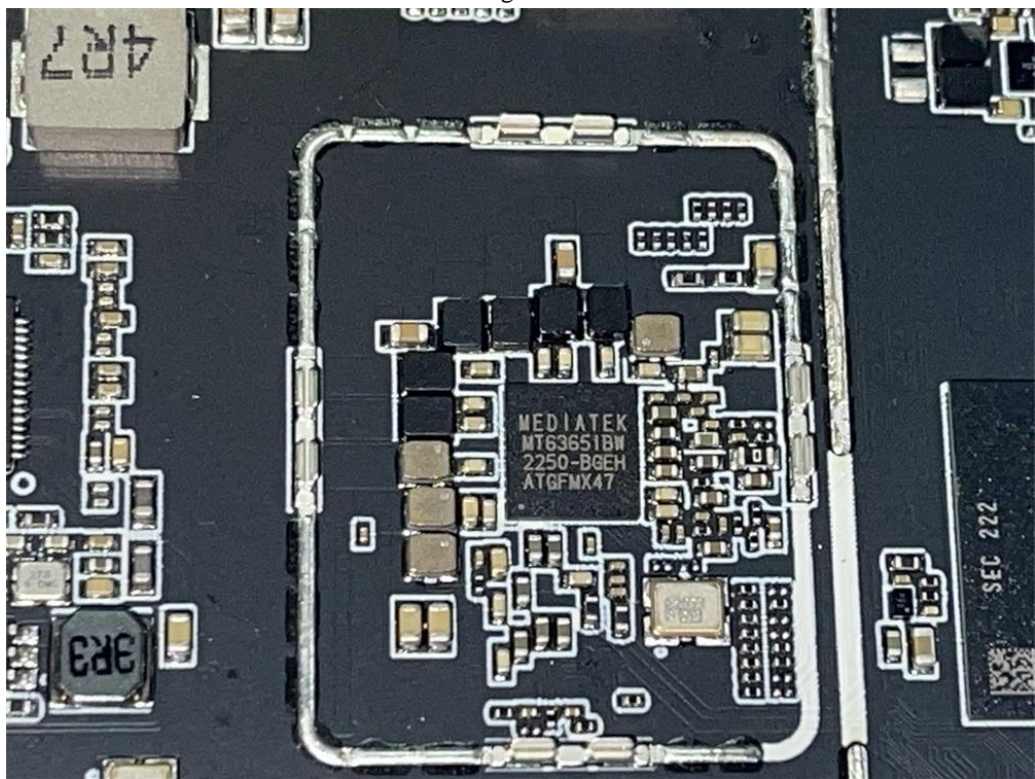

Fig. 27

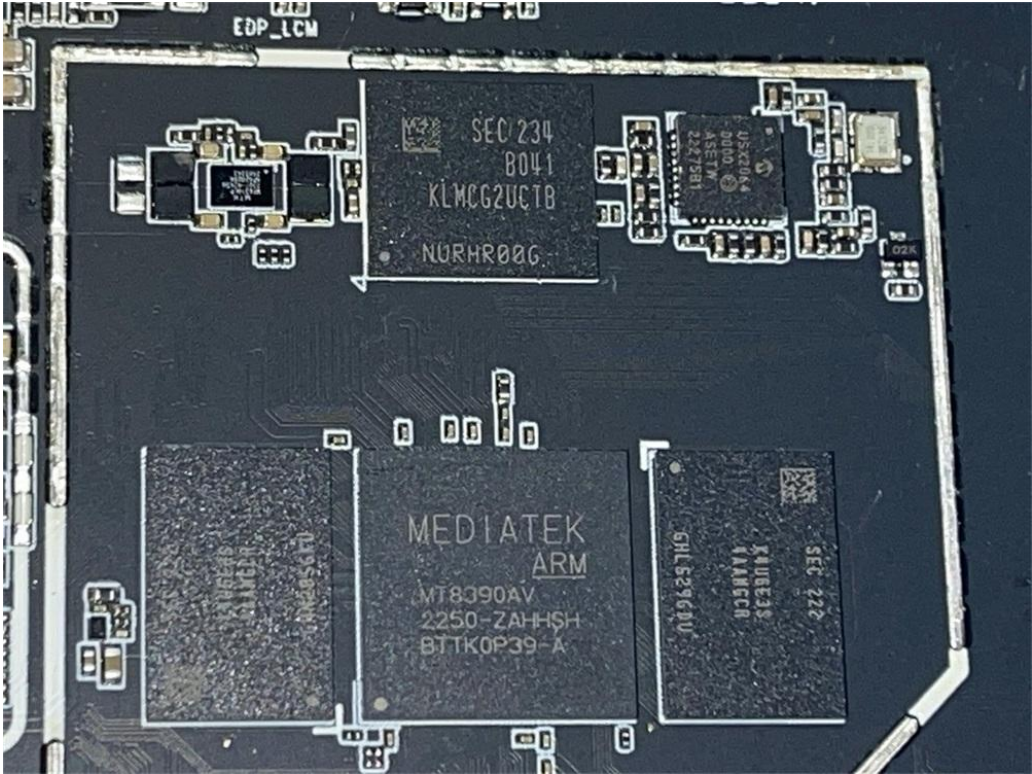

Fig. 28

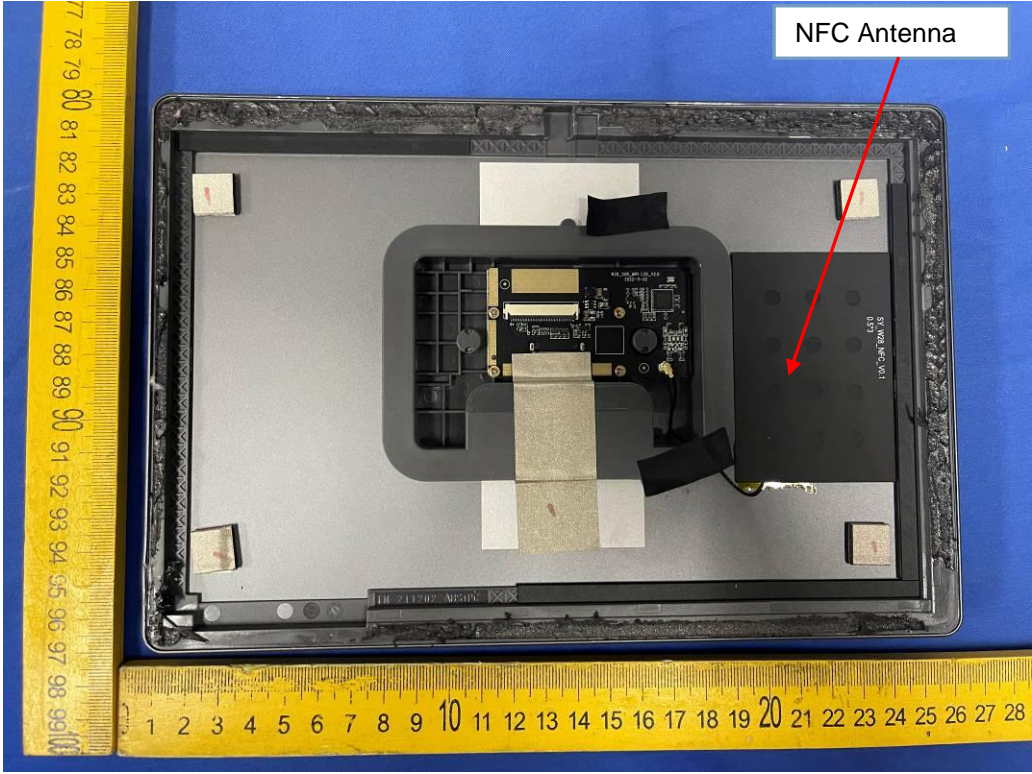

Fig. 29

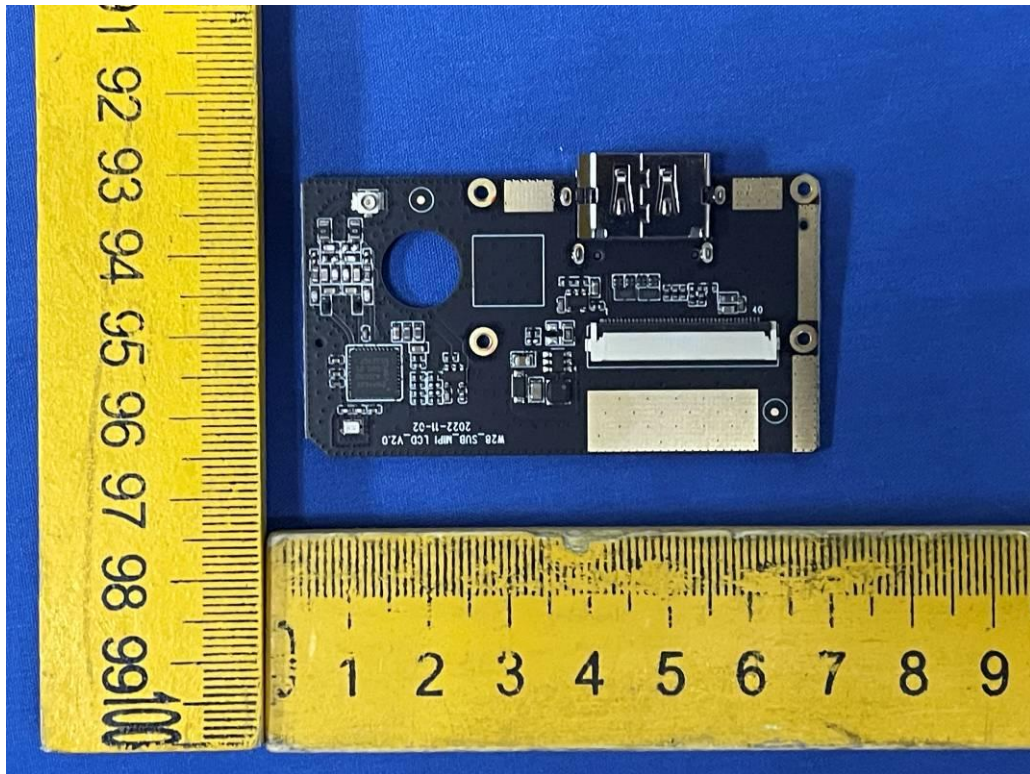

Fig. 30

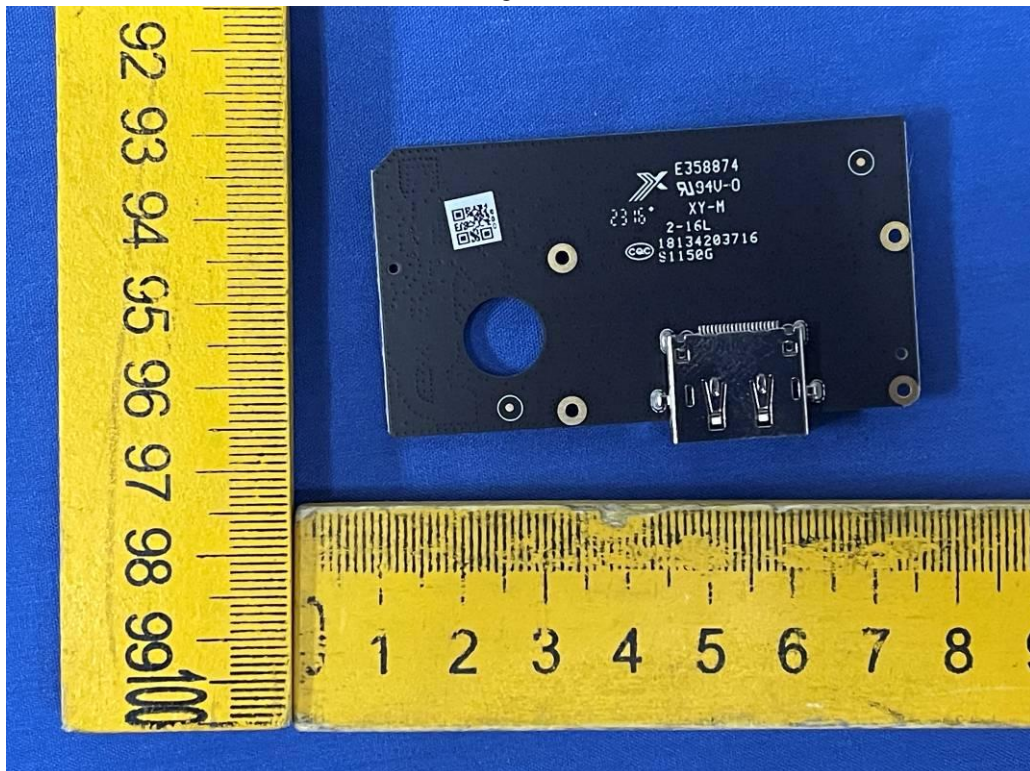

Fig. 31

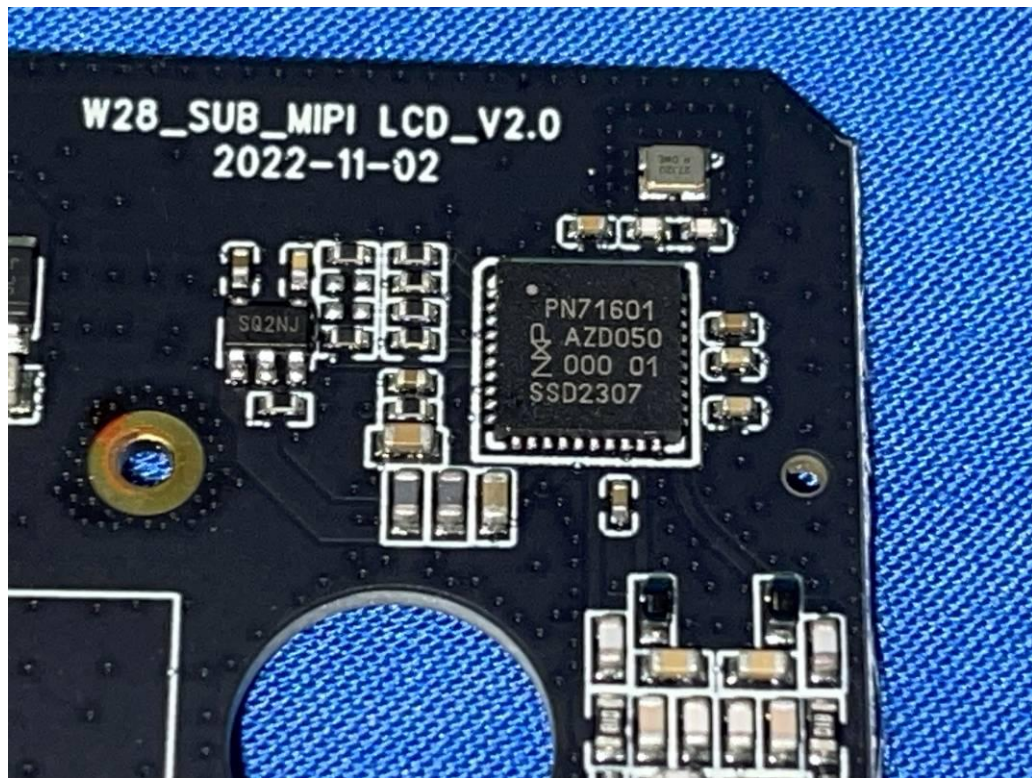

Fig. 32

.....End of Report.....