

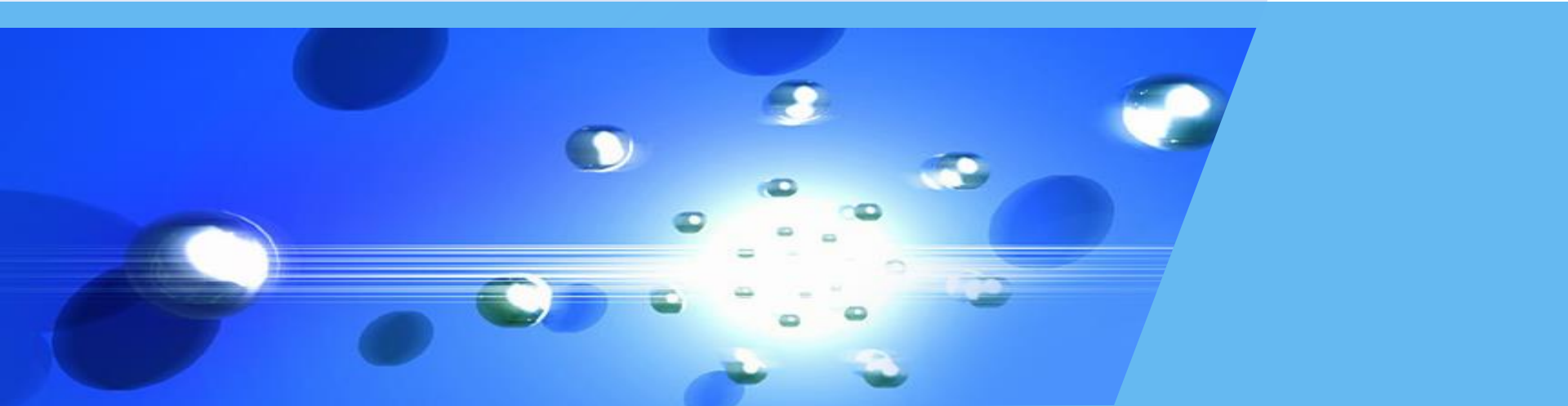

专业的**RF**研发机构



深圳安创智联电子有限公司

Antenna debugging report

| | | | | | |
|-----------------------------|-----------|-------|--|------|-------------|
| Customer: | 佳信捷 | 项目-主板 | | Date | 2023. 4. 21 |
| Frequency band | 2400-2500 | | | | |
| Antenna structure | FPC ANT | | | | |
| Radio frequency engineering | 易龙辉 | | | | |
| Structural engineering | 卿创辉 | | | | |
| Report version | V1.0 | | | | |

SATIMO Dark room

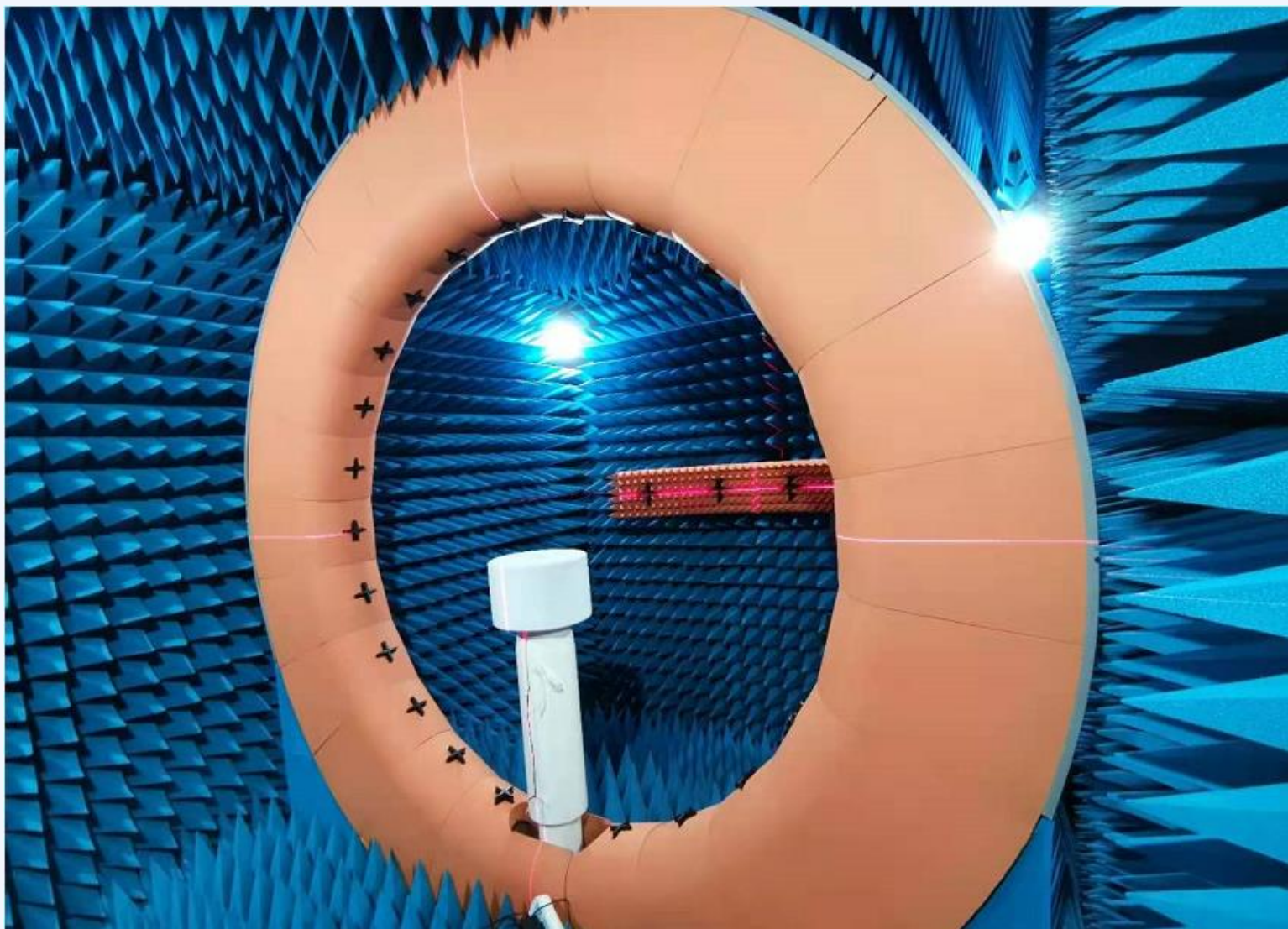

Test system

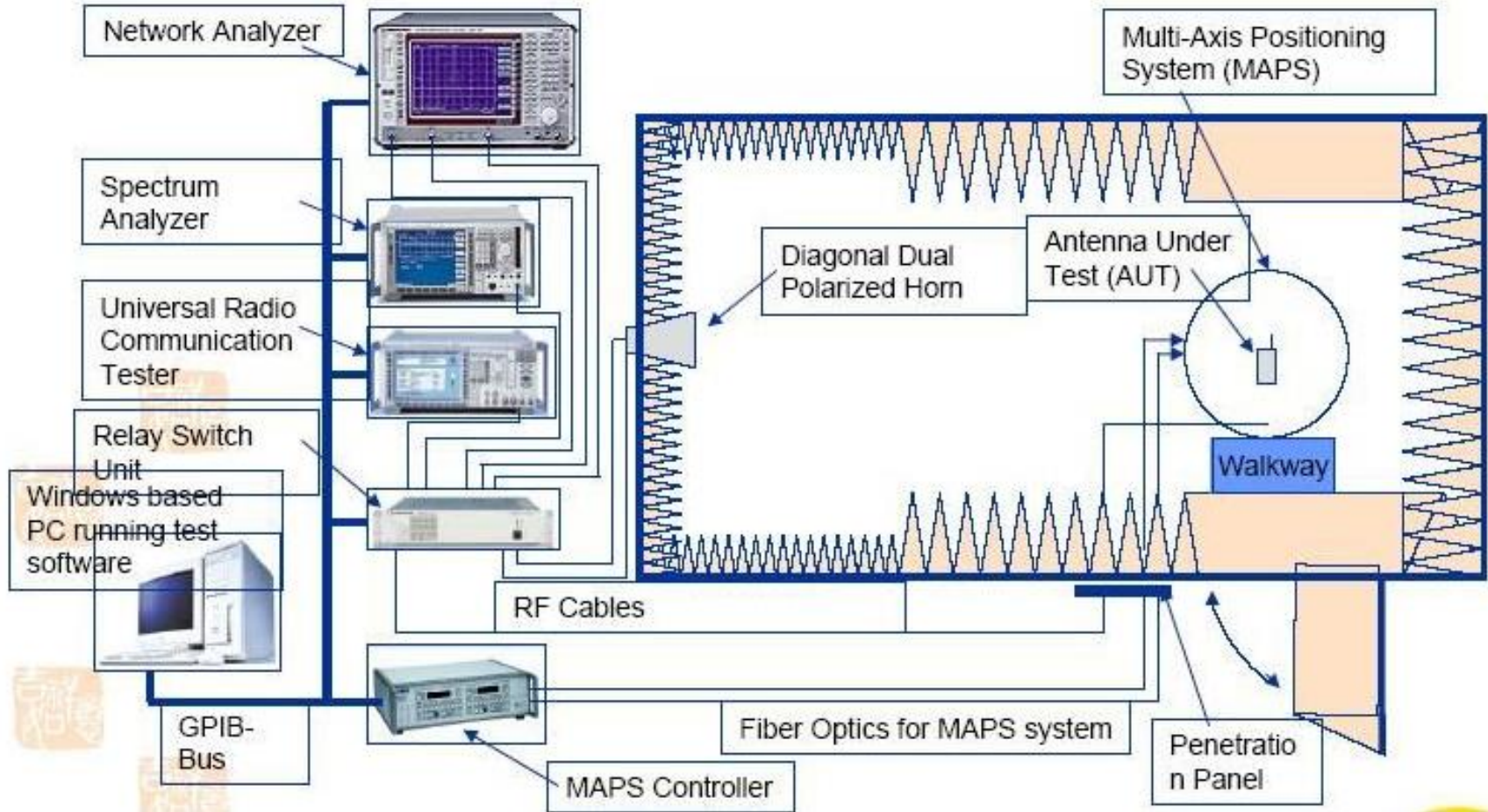

1.2 测试环境

| | |
|------|----------------------------|
| 测试环境 | XH-IOE MPS2440 Test System |
| 环境温度 | 23°C |
| 环境湿度 | 52% |
| 环境气压 | 101KPa |

- 1、Product drawing
- 2、Matching circuit
- 3、Test data

Product drawing

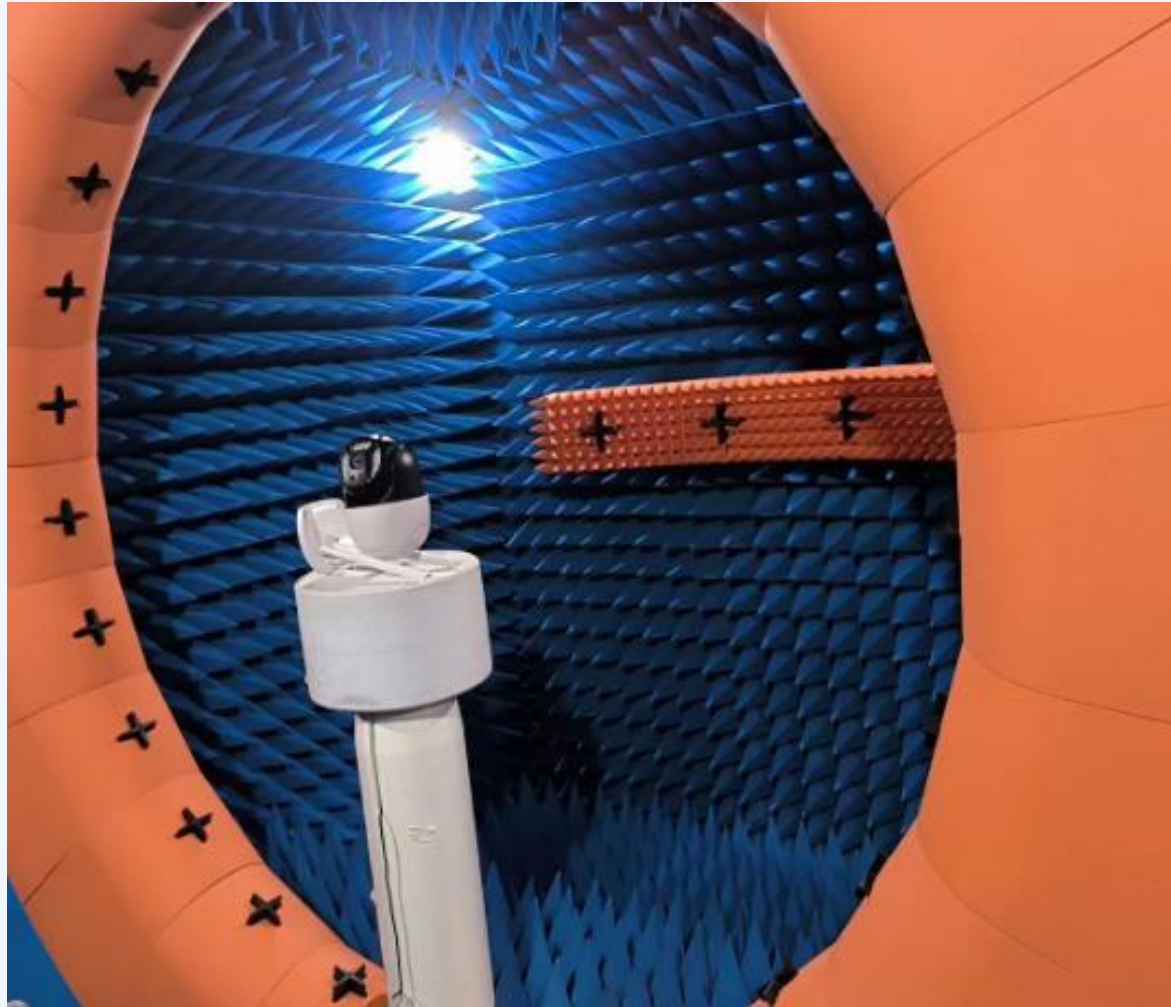

Matching circuit

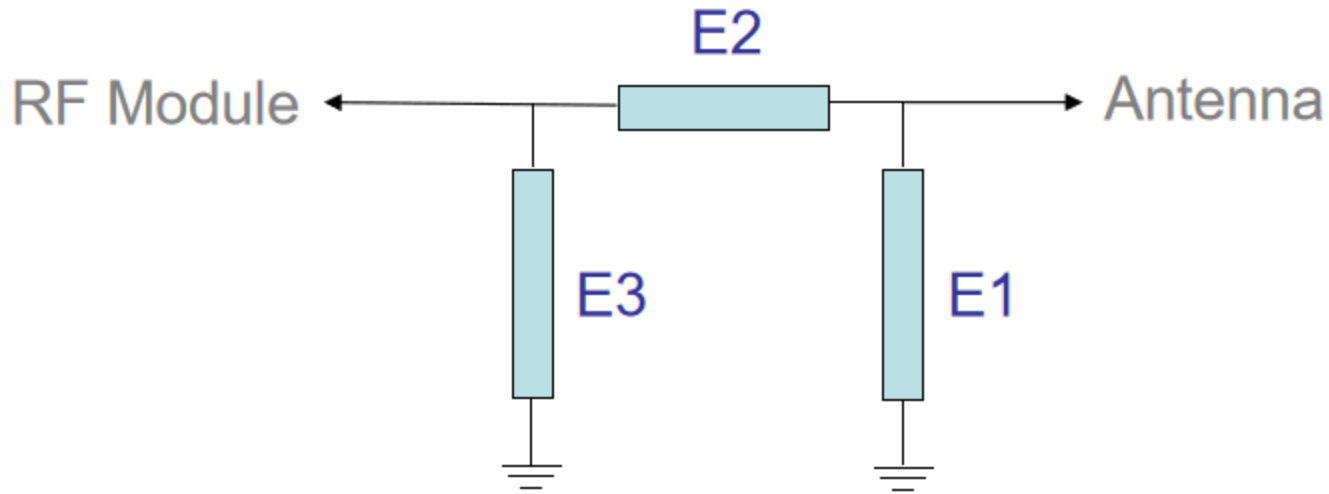

| Element | Value |
|----------|-------|
| E1(0402) | |
| E2(0402) | |
| E3(0402) | |
| 原匹配无改动 | |

Antenna passive parameter

| Frequency | Efficiency | Efficiency | Gain/ dBi |
|-----------|------------|------------|-----------|
| 2400 | -2.61 | 54.83 | 2.25 |
| 2410 | -2.49 | 56.36 | 2.66 |
| 2420 | -2.57 | 55.34 | 2.7 |
| 2430 | -2.52 | 55.98 | 2.85 |
| 2440 | -2.33 | 58.48 | 3.04 |
| 2450 | -2.49 | 56.36 | 3.08 |
| 2460 | -2.61 | 54.83 | 2.94 |
| 2470 | -2.55 | 55.59 | 3.05 |
| 2480 | -2.72 | 53.46 | 2.89 |
| 2490 | -3.01 | 50 | 2.52 |
| 2500 | -2.85 | 51.88 | 2.75 |

Standing wave pattern

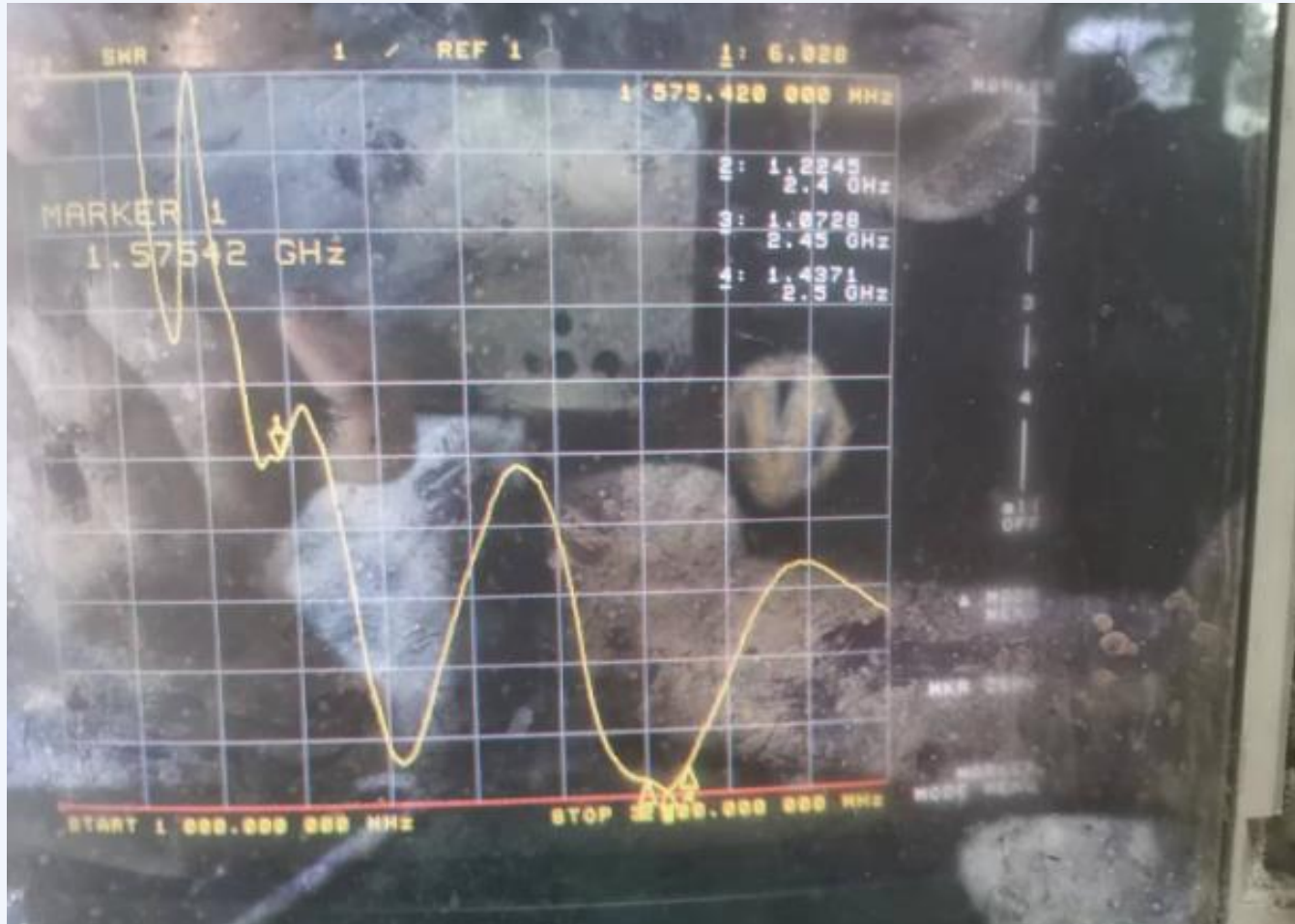

Direction chart

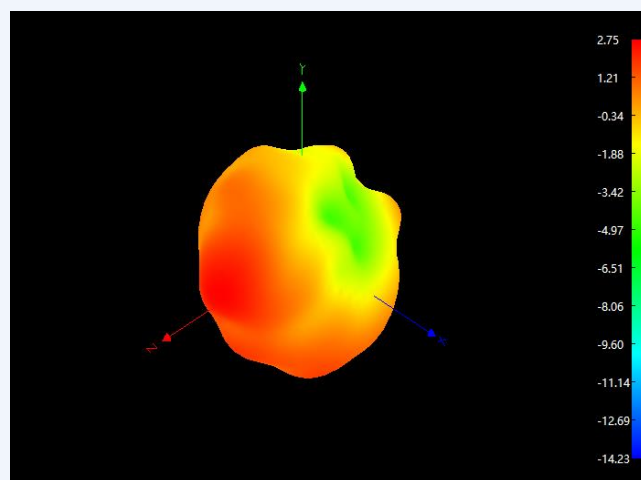
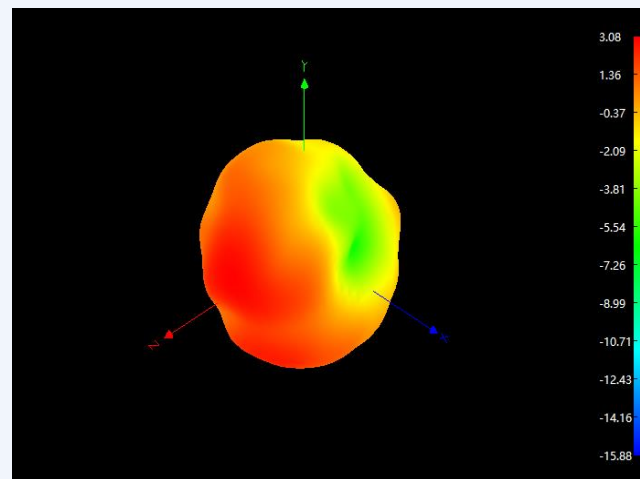
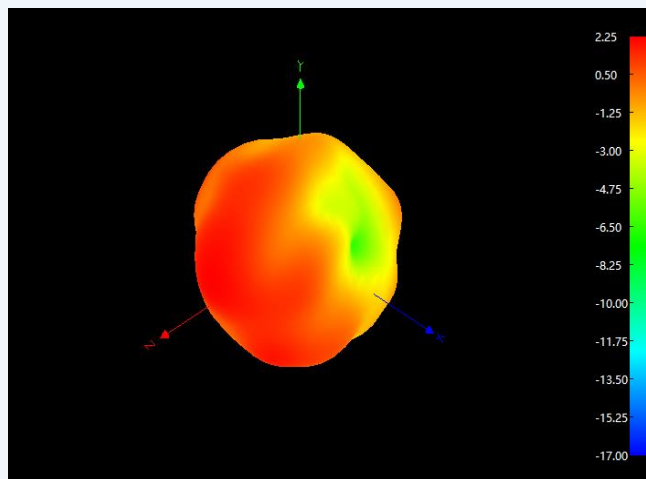

Antenna picture



專業的**RF**研發機構

Thank You !

