

# Dongguan Pan Asia electronics Co., LTD

Shijie Town, Dongguan City, lumbar junction tetracarboxylic tetracarboxylic sand  
behind the post office, Dongguan City, Guandong,China

## SPECIFICATION FOR APPROVAL

客 户:  
CUSTOMER:

客 户 料 号:  
CUST P/N:

产 品 料 号: 0.08\*48P  
FINE P/N:

产 品 型 号:  
DESC:

6.3UH10%\43.5\*.20.5\*0.6 Slotted back glue Outlet length30mm(±2mm)

日 期:  
DATE:

2023/07/26

版 本:  
Version:

制作 PREPARED BY	审核 CHECKED BY	批准 APPROVED BY	客户承认 CUSTOMER APPROVE



# SPECIFICATION

產品型號:

DESC

Φ43.5x20.5-10Ts-0.08x48P-30mm

版本

Rev: A.0

客戶 CUST:

料号 Fine P/N:

客戶料号 CUST P/N:

331

FYD331003

A11

一、尺寸 DIMENSION:(mm)

A 40±0.5

B 20±0.5

C 0.6厚0.6 thick

D1 32mm±2

D2 30mm±2

二、原理图 SCHEMATIC DIAGRAM:

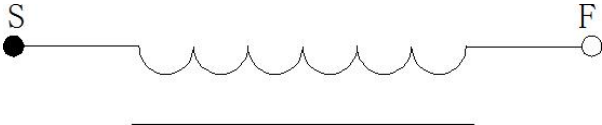

三、绕线参数 Winding Specification:

F 43.6±0.2

G 8.0 ref

H 1.3±1

I 5.3 ref

E 3±0.2

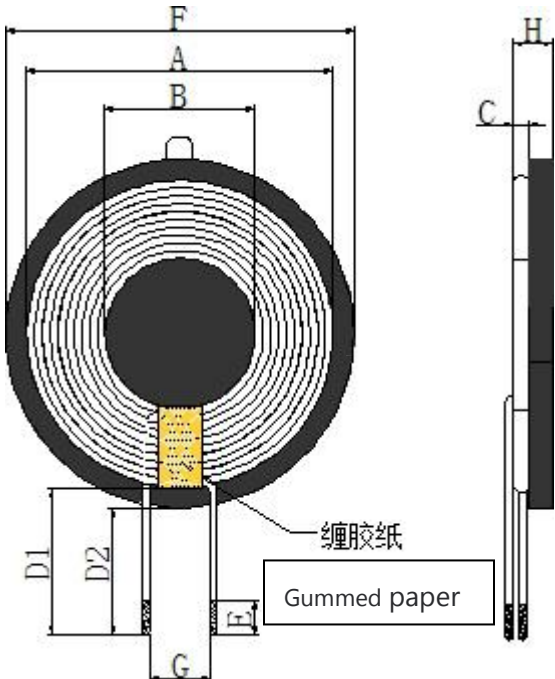

Note:

1. Coil attached magnetic disc, magnetic disc size 43.5±0.2mm, thickness is 0.6
2. Wrap 8mm(ref) width high-temperature adhesive paper 1-2Ts around the coil outlet position;
3. Stick a circular diameter on the back of the disc 42mm(ref) white double-sided tape, inner hole 20.5/8.6mm (ref), (must add 3mm double-sided tape with hole).

序号 NO.	端子 TERMINAL		线径 WIRE	圈数 Turns	绕线方向 Winding Direction
1	S	F	热风线 0.08*48P	10Ts	CCW

四、电气特性 ELECTRICAL CHARACTERISTICS:

温度 TEMPERATURE:25±10°C, 湿度 RELATIVE HUMIDITY:75±20%

序号 NO.	项目 ITEM	端子 TERMINAL	标准 SPECIFICATION	测试条件 TEST FREQUENCY	测试仪器 TEST EQUIPMENTS
1	IND.	S-F	5.4uH ±15% Individual coil	100KHz/1.0V	LCZ METER 1062B
2	IND.	S-F	6.5uH ±15% Magnetized sheet	100KHz/1.0V	LCZ METER 1062B
3	DCR	S-F	≤50mΩ		LCZ METER 502B

擬制/日期 PREPARED BY/DATE

2023/7/26

審核/日期 CHECKED BY/DATE

2023/7/26