

Dongguan Pan Asia electronics Co., LTD

SPECIFICATION FOR APPROVAL

客 户: _____
 CUSTOMER:
 客 户 料 号: _____
 CUST P/N:
 产 品 料 号: 0.08*48P
 FINE P/N: _____
 产 品 型 号: 6.3UH10%\43.5*.20.5*0.6 Slotted back glue Outlet length5mm (±2mm)
 DESC: _____
 日 期: **2023/07/26**
 DATE:
 版 本: _____
 Version:

制作 PREPARED BY	审核 CHECKED BY	批准 APPROVED BY	客户承认 CUSTOMER APPROVE

版本變更履歷

Version Change History

版本 Rev.	變更前 Before Change	變更後 After Change	更改日期 Change Date	批准 Approved By
A.0	新发行	----	2023/7/26	
1		6.5UH		
2				
3				
4				
5				
6				
7				
8				
9				
10				

SPECIFICATION

產品型號:

DESC

Φ43.5x20.5-10Ts-0.08x48P-30mm

版本

Rev: A.0

客戶 CUST:

料号 Fine P/N:

客戶料号 CUST P/N:

331

FYD331003

A11

一、尺寸 DIMENSION:(mm)

二、原理图 SCHEMATIC DIAGRAM:



三、绕线参数 Winding Specification:

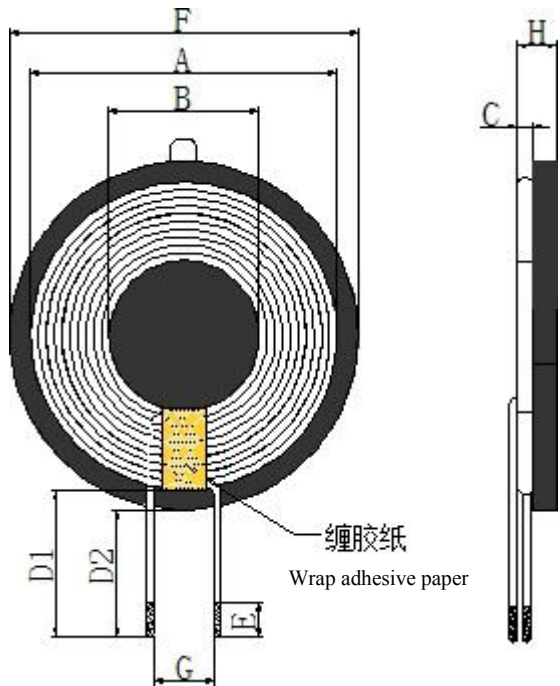

- A 40±0.5
- B 20±0.5
- C 0.6厚thickness
- D1 7mm±2
- D2 5mm±2
- F 43.6±0.2
- G 8.0 ref
- H 1.3±1
- I 5.3 ref

E 3±0.2

注:

- 1.线圈贴磁片, 磁片尺寸 43.5±0.2mm,,厚度为0.6
- 2.线圈出线位置缠8mm(ref)宽度高温胶纸 1-2Ts;
- 3.磁片反面贴圆形直径 42mm(ref)白色双面胶,内孔 20.5/8.6mm (ref), (必须加带孔 3mm双面胶)。

Note:

1. Coil attached magnetic disc, magnetic disc size 43.5±0.2mm, thickness is 0.6
2. Wrap 8mm(ref) width high-temperature adhesive paper 1-2Ts around the coil outlet position;
3. Stick a circular diameter on the back of the disc 42mm(ref) white double-sided tape, inner hole 20.5/8.6mm (ref), (must add 3mm double-sided tape with hole).

序号 NO.	端子 TERMINAL		线径 WIRE	圈数 Turns	绕线方向 Winding Direction
1	S	F	Bare copper wire 0.08*48P	10Ts	CCW

四、电气特性 ELECTRICAL CHARACTERISTICS:

温度 TEMPERATURE:25±10°C, 湿度 RELATIVE HUMIDITY:75±20%

序号 NO.	项目 ITEM	端子 TERMINAL	标准 SPECIFICATION	测试条件 TEST FREQUENCY	测试仪器 TEST EQUIPMENTS
-----------	------------	----------------	---------------------	------------------------	-------------------------

1	IND.	S-F	5.4uH ±15%单独 Individual coil	100KHz/1.0V	LCZ METER 1062B
2	IND.	S-F	6.5uH ±15%加磁片 Magnetized sheet	100KHz/1.0V	LCZ METER 1062B
3	DCR	S-F	≤50mΩ		LCZ METER 502B

擬制/日期 PREPARED BY/DATE

2023/7/26

審核/日期 CHECKED BY/DATE

2023/7/26