

Instructions for 86mm size receiver system



AC227-01
Single route radio receiver



AC228-01
Double route radio receiver

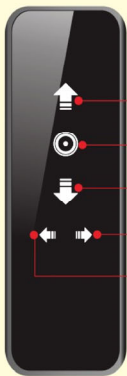

UP
STOP
DOWN
RIGHT
LEFT

AC123 transmitter with touch screen



PROG

I. Features

- Built-in silver screen printing button, beautiful and lasting.
- Anti-scratches acrylic surface, built-in lamp light guide, soft and well-distributed.
- Roast piano lacquer frame, noble and elegant.
- Shock-proof TV5 relays.
- SMT machine automatic assembly in damp-proof enclosure.

⚠ Installation Note

Besides the Standard of Electric Safety, please follow:

- Do not install the receiver in or too close to any metallic parts or it will affect the receive distance;
- Effective signal distance: 80m in open area;
- Minimum distance between the Receiver and the floor: 1.5m;
- Minimum distance between the Receiver and the roof: 0.3m;
- Minimum distance between the Receiver and the transmitter: 0.2m;
- Make sure the power has been cut off before wiring to ensure safety;
- Avoid static disturbance which could damage electronic components
- Use flexible cables;
- Ensure no longitudinal force is acting on cables after installation.

II Parameter

Model No.	Input voltage	Working temperature	Loading power	Receiving frequency	Receiving sensitivity	Transmitters quantity allowed	Operation
AC227-01	AC 230V optional AC 120V	-40°C~+85°C	≤ 500W	433.92MHz	-110dBm	single route ≤ 20	remote/manual
AC228-01						double route ≤ 20	

III. Installation and wiring

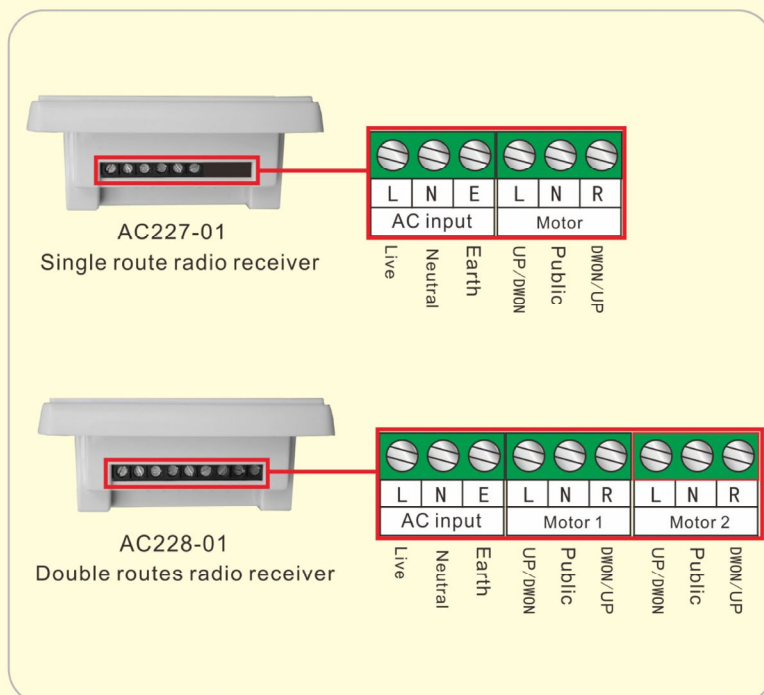
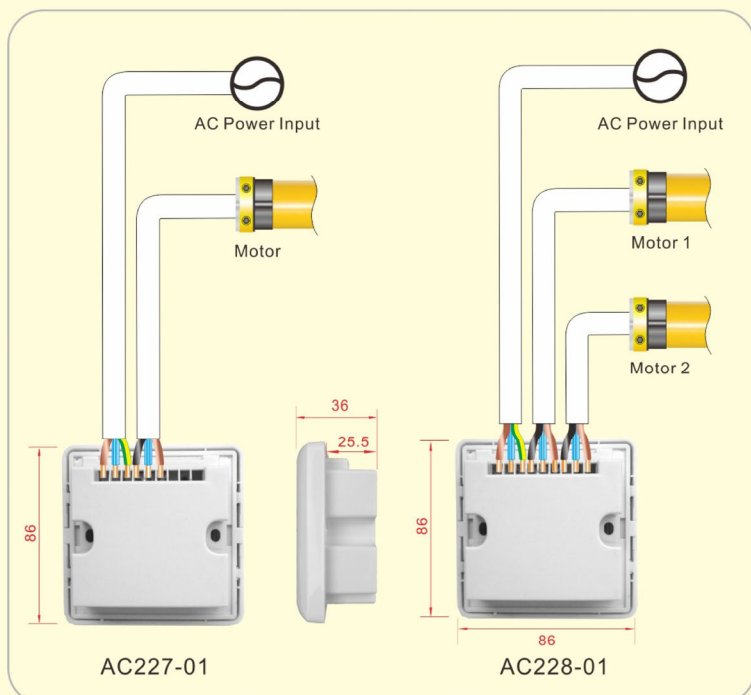

IV. Product diagram

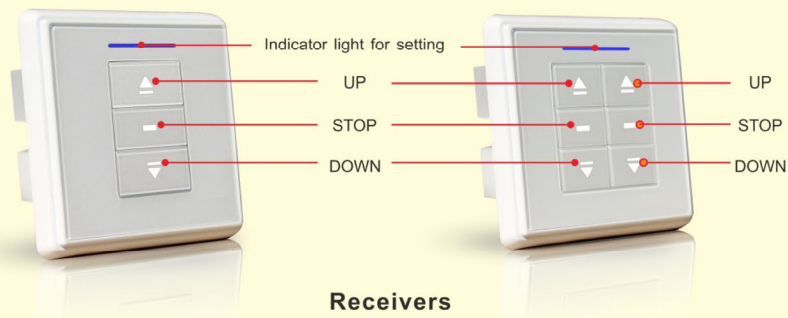

V. Installation instruction

- * 5Mins is the longest operation time for motor;
- * 0.5S to transfer for up/down for motor.
- * There is the same adjustment method used in single route receiver and double route receiver.
- * Please choose the channel firstly when the transmitter is multi-channel.

1. Programming

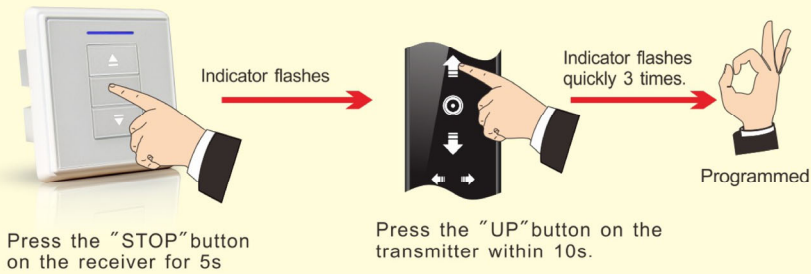

2. Direction coversion

- * If the motor operates in a correct direction, no need to do the coversion, if not, it is necessary.

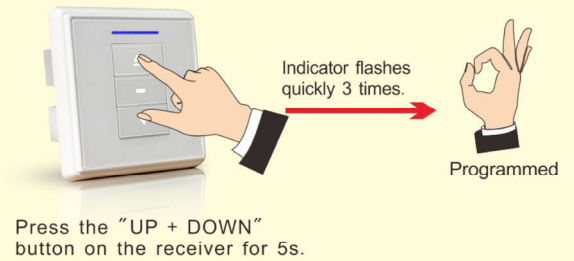

3. Dot-moving and continuous-moving transfer

- Remarks: Operation under dot moving mode, press UP/DOWN button >1.5s, motor move continuous, press UP/DOWN button <1.5s, motor move dot by dot.

Method 1:

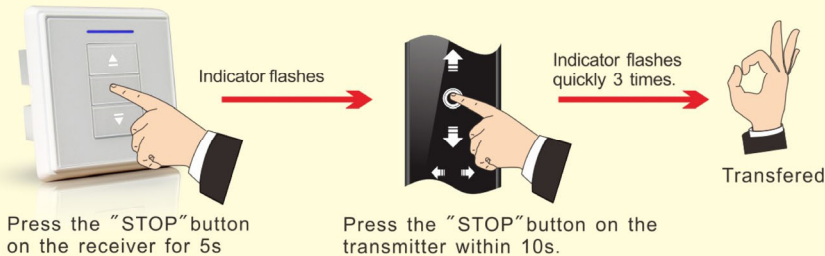

Method 2:

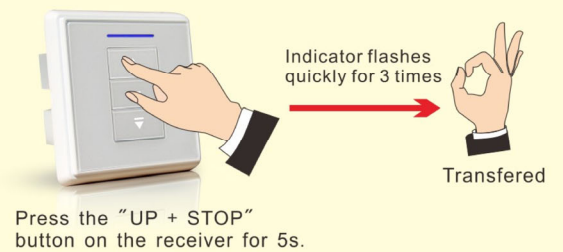

4.Delete single code

- *The single channel memory on the transmitter will be deleted after operation

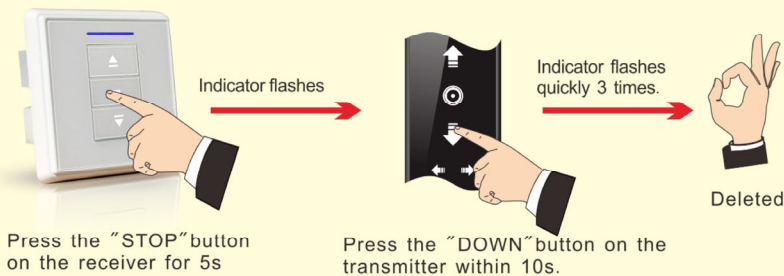

5.Delete all codes

- * All memories on the receiver will be all deleted after operation

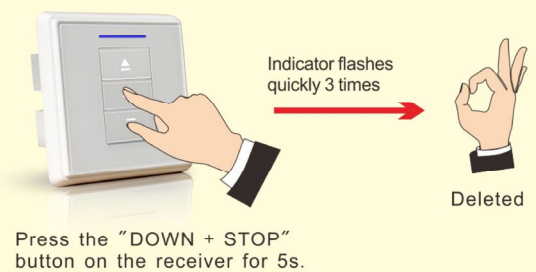

VI. Trouble and shootings

No.	Performance	Checking point
1	Indicator on receiver do not light	Please check wiring connection for receiver
2	Indicator on transmitter do not light or poor light	Please check the battery power and installation
3	Transmitter and receiver work commonly, but motor has no rotating	Please check the motor wiring

FCC STATEMENT :

This device complies with Part 15 of the FCC Rules. Operation is subject to the following two conditions:

- (1) This device may not cause harmful interference, and
- (2) This device must accept any interference received, including interference that may cause undesired operation.

Warning: Changes or modifications not expressly approved by the party responsible for compliance could void the user's authority to operate the equipment.

NOTE: This equipment has been tested and found to comply with the limits for a Class B digital device, pursuant to Part 15 of the FCC Rules. These limits are designed to provide reasonable protection against harmful interference in a residential installation. This equipment generates uses and can radiate radio frequency energy and, if not installed and used in accordance with the instructions, may cause harmful interference to radio communications. However, there is no guarantee that interference will not occur in a particular installation. If this equipment does cause harmful interference to radio or television reception, which can be determined by turning the equipment off and on, the user is encouraged to try to correct the interference by one or more of the following measures:

- Reorient or relocate the receiving antenna.
- Increase the separation between the equipment and receiver.
- Connect the equipment into an outlet on a circuit different from that to which the receiver is connected.
- Consult the dealer or an experienced radio/TV technician for help.

RF warning statement:

The device has been evaluated to meet general RF exposure requirement. The device can be used in portable exposure condition without restriction.