



TEST REPORT

Applicant Name : Shenzhen Jiteng Network Technology Co., Ltd
Address : No.1202, Bitian Pavilion, Bizhong Garden, No.10 Bibo First Street,
Bibo Community, Huangbei Street, Luohu District, Shenzhen City,
China
Report Number : SZNS1211111-58026E-00C
FCC ID: 2AY4C-GM

Test Standard (s)
FCC PART 15.407

Sample Description

Product: Mini PC
Trademark: GEEKOM
Tested Model: GM08i5T
Multiple Model: GM08i5S, GMXXiXT, GMXXiXS, GMXXiXSS, GMXXiXTS,
(X substitutes 0, 1, 3, 5, 7, 8)
Date Received: 2021-11-11
Date of Test: 2021-11-16 to 2021-11-25
Report Date: 2021-12-13

Test Result:	Pass*
--------------	-------

* In the configuration tested, the EUT complied with the standards above.

Prepared and Checked By:

Fan Yang
EMC Engineer

Approved By:

Candy Li
EMC Engineer

Note: This report may contain data that are not covered by the A2LA accreditation and are marked with an asterisk "★".

Shenzhen Accurate Technology Co., Ltd. is not responsible for the authenticity of any test data provided by the applicant. Data included from the applicant that may affect test results are marked with an asterisk "**". Customer model name, addresses, names, trademarks etc. are not considered data.

This report cannot be reproduced except in full, without prior written approval of the Company. Unless otherwise stated the results shown in this test report refer only to the sample(s) tested. This report is valid only with a valid digital signature. The digital signature may be available only under the Adobe software above version 7.0.

Shenzhen Accurate Technology Co., Ltd.

1/F., Building A, Changyuan New Material Port, Science & Industry Park, Nanshan District, Shenzhen, Guangdong, P.R. China
Tel: +86 755-26503290 Fax: +86 755-26503396 Web: www.atc-lab.com

TABLE OF CONTENTS

GENERAL INFORMATION	4
PRODUCT DESCRIPTION FOR EQUIPMENT UNDER TEST (EUT)	4
OBJECTIVE	4
TEST METHODOLOGY	4
MEASUREMENT UNCERTAINTY.....	5
TEST FACILITY	5
SYSTEM TEST CONFIGURATION	6
DESCRIPTION OF TEST CONFIGURATION	6
EUT EXERCISE SOFTWARE	6
DUTY CYCLE	7
EQUIPMENT MODIFICATIONS	7
SUPPORT EQUIPMENT LIST AND DETAILS	7
EXTERNAL I/O CABLE.....	8
BLOCK DIAGRAM OF TEST SETUP	9
SUMMARY OF TEST RESULTS	11
TEST EQUIPMENT LIST	12
FCC §1.1310 & §2.1091 –MAXIMUM PERMISSIBLE EXPOSURE (MPE)	13
FCC §15.203 – ANTENNA REQUIREMENT	15
APPLICABLE STANDARD	15
ANTENNA CONNECTOR CONSTRUCTION	15
FCC §15.407 (B) (8) §15.207 (A) – CONDUCTED EMISSIONS	16
APPLICABLE STANDARD	16
EUT SETUP	16
EMI TEST RECEIVER SETUP.....	16
TEST PROCEDURE	16
TEST DATA	17
§15.205 & §15.209 & §15.407(B) (1), (4), (7), (8) , (9), (10) – UNDESIRABLE EMISSION	26
APPLICABLE STANDARD	26
EUT SETUP	26
EMI TEST RECEIVER & SPECTRUM ANALYZER SETUP	27
TEST PROCEDURE	27
FACTOR & MARGIN CALCULATION	28
TEST DATA	28
FCC §15.407(a)(e) – BANDWIDTH	41
APPLICABLE STANDARD	41
TEST PROCEDURE	41
TEST DATA	42
FCC §15.407(a) (1) (3) – CONDUCTED TRANSMITTER OUTPUT POWER	43
APPLICABLE STANDARD	43
TEST PROCEDURE	43
TEST DATA	43
FCC §15.407(a) (1) (3) - POWER SPECTRAL DENSITY	44
APPLICABLE STANDARD	44
TEST PROCEDURE	44
TEST DATA	45
APPENDIX	46

APPENDIX A1: EMISSION BANDWIDTH	46
APPENDIX A2: OCCUPIED CHANNEL BANDWIDTH	76
APPENDIX A3: MIN EMISSION BANDWIDTH.....	106
APPENDIX B: MAXIMUM CONDUCTED OUTPUT POWER	121
APPENDIX C: MAXIMUM POWER SPECTRAL DENSITY	123
APPENDIX D: DUTY CYCLE.....	153

GENERAL INFORMATION

Product Description for Equipment under Test (EUT)

Product	Mini PC
Tested Model	GM08i5T
Multiple Model	GM08i5S, GMXXiXT, GMXXiXS, GMXXiXSS, GMXXiXTS, (X substitutes 0, 1, 3, 5, 7, 8)
Model Difference	Please refer to the DoS letter
Frequency Range	5G Wi-Fi: 5150-5250 MHz; 5725-5850 MHz
Maximum Average Conducted Output Power	5150-5250 MHz 16.62dBm (802.11a), 16.62dBm(802.11n20), 16.64dBm(802.11n40), 16.64dBm (802.11ac20), 16.58dBm (802.11ac40), 16.64dBm (802.11ac80) , 5725-5850 MHz 16.51dBm (802.11a), 16.48dBm(802.11n20), 16.65dBm(802.11n40), 16.80dBm (802.11ac20), 16.59dBm (802.11ac40), 16.47dBm (802.11ac80)
Modulation Technique	OFDM
Antenna Specification*	Internal Antenna: Ant 0: Band1: 2.85dBi, Band4: 4.31dBi (provided by the applicant) Ant 1: Band1: 3.47dBi, Band4: 3.85dBi (provided by the applicant)
Voltage Range	DC 19V from Adapter
Sample number	SZNS1211111-58026E-RF-S1 (Assigned by ATC)
Sample/EUT Status	Good condition
Adapter 1 information	Model: HKA09019047-6U Input: AC 100-240V, 50/60Hz, 1.5A Output: DC 19V, 4.74A
Adapter 2 information	Model: HKA06519034-6J Input: AC 100-240V, 50/60Hz, 1.5A Output: DC 19V, 3.42A
Adapter 3 information	Model: ADS-110CL-19-3 190090E Input: AC 100-240V, 50/60Hz, 1.5A Output: DC 19V, 4.74A
Adapter 4 information	Model: ADS-65HI-19A-3 19065E Input: AC 100-240V, 50/60Hz, 1.5A Output: DC 19V, 3.42A

Objective

This type approval report is in accordance with Part 2-Subpart J, Part 15-Subparts A and E of the Federal Communication Commissions rules.

The tests were performed in order to determine compliance with FCC Part 15, Subpart E, section 15.203, 15.205, 15.207, 15.209 and 15.407 rules.

Test Methodology

All measurements contained in this report were conducted with ANSI C63.10-2013, American National Standard of Procedures for Compliance Testing of Unlicensed Wireless Devices. And KDB789033D02 General U-NII Test Procedures New Rules v02r01.

All emissions measurement was performed at Shenzhen Accurate Technology Co., Ltd. The radiated testing was performed at an antenna-to-EUT distance of 3 meters.

Measurement Uncertainty

Parameter		Uncertainty
Occupied Channel Bandwidth		5%
RF output power, conducted		0.73dB
Unwanted Emission, conducted		1.6dB
AC Power Lines Conducted Emissions		2.72dB
Emissions, Radiated	30MHz - 1GHz	4.28dB
	1GHz - 18GHz	4.98dB
	18GHz - 26.5GHz	5.06dB
	26.5GHz - 40GHz	4.72dB
Temperature		1°C
Humidity		6%
Supply voltages		0.4%

Note: The extended uncertainty given in this report is obtained by combining the standard uncertainty times the coverage factor K with the 95% confidence interval. Otherwise required by the applicant or Product Regulations, Decision Rule in this report did not consider the uncertainty.

Test Facility

The test site used by Shenzhen Accurate Technology Co., Ltd. to collect test data is located on the 1/F., Building A, Changyuan New Material Port, Science & Industry Park, Nanshan District, Shenzhen, Guangdong, P.R. China.

The test site has been approved by the FCC under the KDB 974614 D01 and is listed in the FCC Public Access Link (PAL) database, FCC Registration No.: 708358, the FCC Designation No.: CN1189. Accredited by American Association for Laboratory Accreditation (A2LA) The Certificate Number is 429 7.01.

Listed by Innovation, Science and Economic Development Canada (ISED), the Registration Number is 5077A.

SYSTEM TEST CONFIGURATION

Description of Test Configuration

The system was configured for testing in an engineering mode, which was provided by manufacturer.

The device only supports 5G Wi-Fi 802.11a/n20/n40/ac20/ac40/ac80 modes, which was declared by manufacturer.

For 5150-5250MHz Band, 7 channels are provided to testing:

Channel	Frequency (MHz)	Channel	Frequency (MHz)
36	5180	44	5220
38	5190	46	5230
40	5200	48	5240
42	5210	/	/

For 802.11a, 802.11n20, 802.11ac20 channel 36, 40, 48 were tested;

For 802.11n40/ac40 channel 38, 46 were tested.

For 802.11ac80 channel 42 was tested

For 5725-5850MHz Band, 8 channels are provided to testing:

Channel	Frequency (MHz)	Channel	Frequency (MHz)
149	5745	157	5785
151	5755	159	5795
153	5765	161	5805
155	5775	165	5825

For 802.11a, 802.11n20, 802.11ac20 channel 149, 157, 165 were tested; For 802.11n40/ac40, channel 151, 159 were tested. For 802.11ac80, channel 155 were tested.

EUT Exercise Software

“DRTU”** software was used to test and power level as below:

Ant 0:

Frequency Range (MHz)	Mode	Data rate	Power Level*		
			Low Channel	Middle Channel	High Channel
5150-5250/ 5725-5850	802.11a	6Mbps	12	12	12
	802.11n20	MCS0	12	12	12
	802.11n40	MCS0	12	12	12
	802.11 ac20	MCS0	12	12	12
	802.11 ac40	MCS0	12	12	12
	802.11 ac80	MCS0	12	12	12

Ant 1:

Frequency Range (MHz)	Mode	Data rate	Power Level*		
			Low Channel	Middle Channel	High Channel
5150-5250/ 5725-5850	802.11a	6Mbps	12	12	12
	802.11n20	MCS0	12	12	12
	802.11n40	MCS0	12	12	12
	802.11 ac20	MCS0	12	12	12
	802.11 ac40	MCS0	12	12	12
	802.11 ac80	MCS0	12	12	12

The worst-case data rates are determined to be as above for each mode based upon investigations by measuring the average power and PSD across all data rates, bandwidths and modulations. The device supports SISO and MIMO 2T2R in all modes. Per pretest, 2TX mode was the worst mode and recorded in this report.

Duty cycle

Please refer to the Appendix.

Equipment Modifications

No modification was made to the EUT tested.

Support Equipment List and Details

Manufacturer	Description	Model	Serial Number
DELL	Keyboard	KB216d1	Unknown
DELL	Mouse	MS116c	Unknown
PHILIPS	Monitor	275M7C	UK02141059255272
XIAOMI	TV	L43M5-ES	25131/114100057334
DELL	laptop	LatitudeE5570	6DCCRC2
Kingston	U-DISK	DTSE9 16GB	Unknown
SanDisk	SD Card	Ultra 32GB	Unknown
HUAWEI	Mobile Phone 1	HUAWEI Mate30	FEC0220506013544
XIAOMI	Mobile Phone 2	MI 10	957921bb
HUAWEI	Earphone	Unknown	Unknown

External I/O Cable

Cable Description	Length (m)	From Port	To
Unshielded Detachable AC output Cable	1.0	Adapter	LISN
Unshielded Detachable DC power Cable	1.5	EUT	Adapter 1
Unshielded Detachable DC power Cable	1.2	EUT	Adapter 2
Unshielded Detachable DC power Cable	1.2	EUT	Adapter 3
Unshielded Detachable DC power Cable	1.5	EUT	Adapter 4
Unshielded Detachable HDMI Cable	1.05	EUT	TV
Unshielded Detachable DP Cable	0.95	EUT	Monitor
Unshielded Detachable USB Cable	1.5	EUT	Mouse
Unshielded Detachable USB Cable	1.5	EUT	Keyboard
Unshielded Detachable RJ45 Cable	3	EUT	Notebook
Unshielded Detachable earphone Cable	0.75	EUT	Earphone
Unshielded Detachable USB Cable	1.15	EUT	Mobile phone1
Unshielded Detachable USB Cable	0.95	EUT	Mobile phone2

Block Diagram of Test Setup

For conducted emission:
AC Mains:

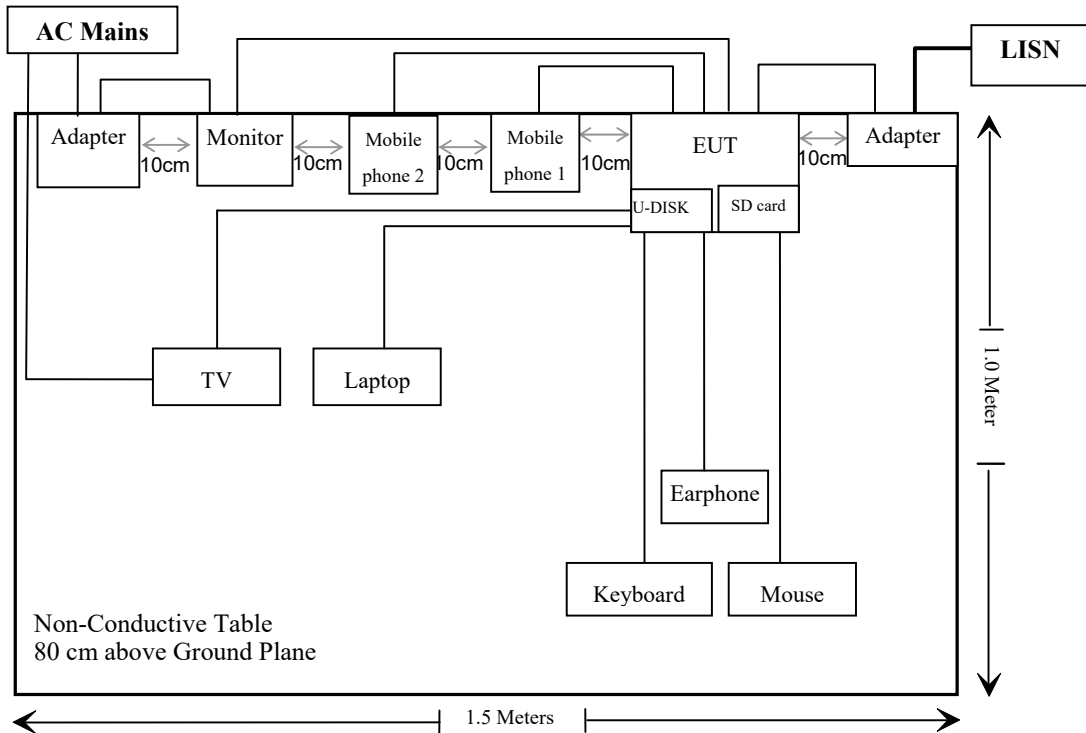

For Radiated emission:
Below 1GHz:

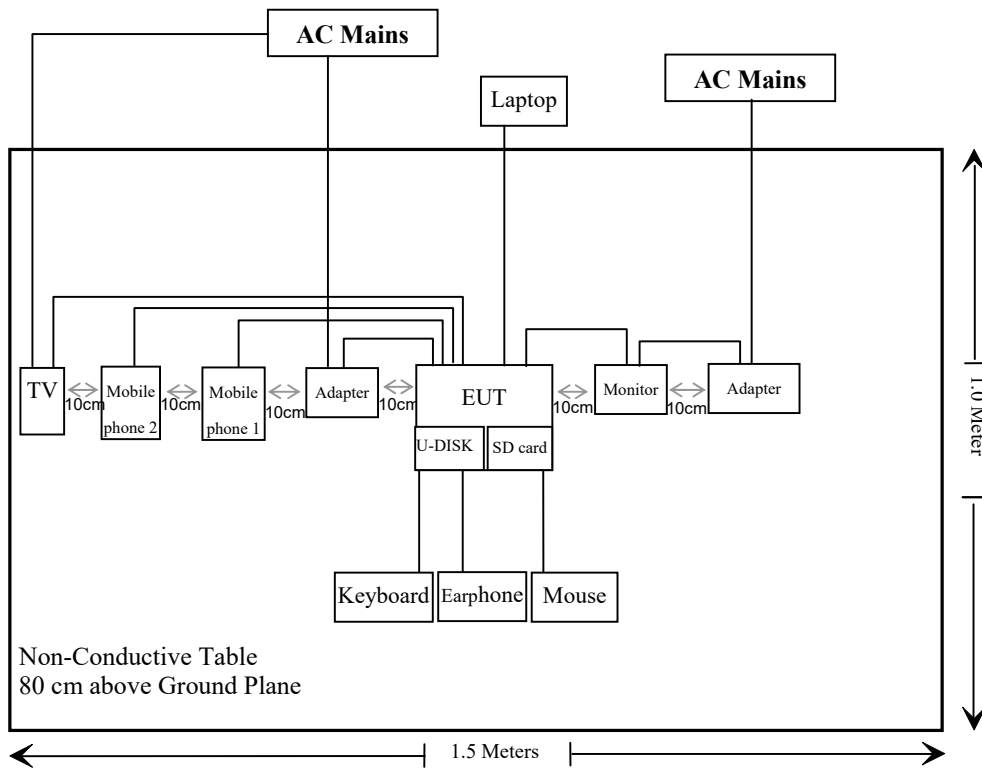

Above 1GHz:

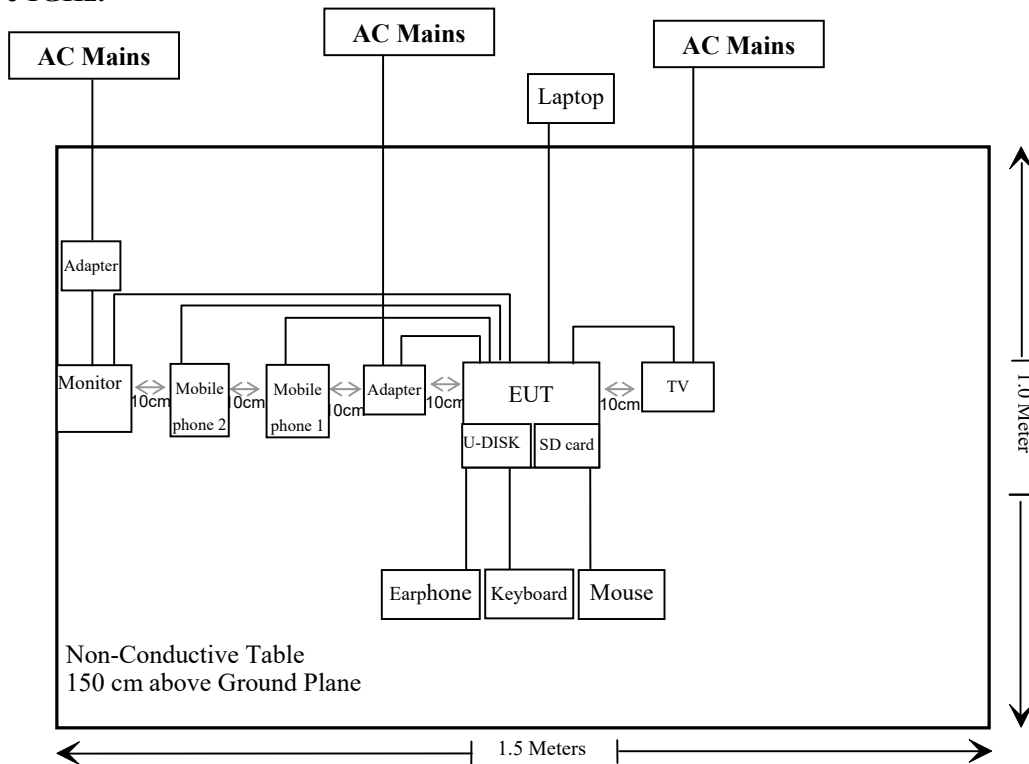

SUMMARY OF TEST RESULTS

FCC Rules	Description of Test	Result
§1.1310 & §2.1091	Maximum Permissible Exposure (MPE)	Compliant
§15.203	Antenna Requirement	Compliant
§15.407(b)(8) & §15.207(a)	Conducted Emissions	Compliant
§15.205 & §15.209 & §15.407(b) (1), (4), (7), (8), (9), (10)	Undesirable Emission& Restricted Bands	Compliant
§15.407(a) (12), (e)	Bandwidth	Compliant
§15.407(a) (1), (3)	Conducted Transmitter Output Power	Compliant
§15.407 (a) (1), (3)	Power Spectral Density	Compliant

Note: Per pre-test with models of GM08i5T and GM08i5S, and the worst case about maximum emission is model of GM08i5T, which was recorded in this report.

TEST EQUIPMENT LIST

Manufacturer	Description	Model	Serial Number	Calibration Date	Calibration Due Date
Conducted Emissions Test					
Rohde& Schwarz	EMI Test Receiver	ESCI	100784	2021/02/03	2022/02/02
R & S	L.I.S.N.	ENV216	101314	2020/12/25	2021/12/24
Anritsu Corp	50Ω Coaxial Switch	MP59B	6200506474	2020/12/25	2021/12/24
Unknown	RF Coaxial Cable	N-2m	No.2	2020/12/25	2021/12/24
Conducted Emission Test Software: e3 19821b(V9)					
Radiated Emissions Test					
Rohde& Schwarz	Test Receiver	ESR	102725	2020/12/25	2021/12/24
Rohde&Schwarz	Spectrum Analyzer	FSV40	101949	2021/5/18	2022/5/17
A.H. Systems, inc.	Preamplifier	PAM-0118P	531	2021/11/9	2022/11/8
Quinstar	Amplifier	QLW-184055 36-J0	15964001002	2020/11/28	2021/11/27
SONOMA INSTRUMENT	Amplifier	310 N	186131	2020/12/25	2021/12/24
Anritsu Corp	50 Coaxial Switch	MP59B	6100237248	2020/12/25	2021/12/24
Schwarzbeck	Bilog Antenna	VULB9163	9163-323	2020/01/05	2023/01/04
Schwarzbeck	Horn Antenna	BBHA9120D	9120D-1067	2020/01/05	2023/01/04
Schwarzbeck	HORN ANTENNA	BBHA9170	9170-359	2020/01/05	2023/01/04
Unknown	RF Coaxial Cable	N-5m	No.3	2020/12/25	2021/12/24
Unknown	RF Coaxial Cable	N-1m	No.5	2020/12/25	2021/12/24
Unknown	RF Coaxial Cable	N-10m	No.7	2021/11/09	2022/11/08
Unknown	RF Coaxial Cable	N-2m	No.8	2021/11/09	2022/11/08
CD	Band Reject Filter	BRM-5.15/5.3 5g-45	075	2020/12/25	2021/12/24
CD	High Pass Filter	WHNX6.0/26. 5G-6SS	4	2020/12/25	2021/12/24
Radiated Emission Test Software: e3 19821b(V9)					
RF Conducted Test					
Rohde&Schwarz	Spectrum Analyzer	FSV40	101949	2021/5/18	2022/5/17
Rohde & Schwarz	Open Switch and Control Unit	OSP120 +OSP -B157	101244 + 100866	2020/12/24	2021/12/23

* **Statement of Traceability:** Shenzhen Accurate Technology Co., Ltd. attests that all calibrations have been performed in accordance to requirements that traceable to National Primary Standards and International System of Units (SI).

FCC §1.1310 & §2.1091 –MAXIMUM PERMISSIBLE EXPOSURE (MPE)

Applicable Standard

According to subpart §2.1091 and subpart §1.1310, systems operating under the provisions of this section shall be operated in a manner that ensures that the public is not exposed to radio frequency energy level in excess of the Commission's guidelines.

Limits for Maximum Permissible Exposure (MPE) (§1.1310, §2.1091)

(B) Limits for General Population/Uncontrolled Exposure				
Frequency Range (MHz)	Electric Field Strength (V/m)	Magnetic Field Strength (A/m)	Power Density (mW/cm²)	Averaging Time (minutes)
0.3-1.34	614	1.63	*(100)	30
1.34-30	824/f	2.19/f	*(180/f ²)	30
30-300	27.5	0.073	0.2	30
300-1500	/	/	f/1500	30
1500-100,000	/	/	1.0	30

f = frequency in MHz; * = Plane-wave equivalent power density;

According to §1.1310 and §2.1091 RF exposure is calculated.

Calculated Formulary:

Predication of MPE limit at a given distance

$S = PG/4\pi R^2$ = power density (in appropriate units, e.g. mW/cm²);

P = power input to the antenna (in appropriate units, e.g., mW);

G = power gain of the antenna in the direction of interest relative to an isotropic radiator, the power gain factor, is normally numeric gain;

R = distance to the center of radiation of the antenna (appropriate units, e.g., cm);

Calculated Data:

For simultaneously transmit system, the calculated power density should comply with:

$$\sum_i \frac{S_i}{S_{Limit,i}} \leq 1$$

For worst case:

Mode	Frequency Range (MHz)	Antenna Gain		Tune-up Output Power		Evaluation Distance (cm)	Power Density (mW/cm ²)	MPE Limit (mW/cm ²)
		(dBi)	(numeric)	(dBm)	(mW)			
BT	2402-2480	1.89	1.55	7.00	5.01	20	0.0015	1.0
2.4G Wi-Fi	2412-2462	2.68	1.85	19.50	89.13	20	0.0329	1.0
5G Wi-Fi Band 1	5150-5250	3.47	2.22	17.00	50.12	20	0.0222	1.0
5G Wi-Fi Band 4	5725-5850	4.31	2.70	17.00	50.12	20	0.0269	1.0

Note: 1. The BT function can transmit at the same time with the Wi-Fi function.

2. The 2.4G Wi-Fi function can transmit at the same time with the 5G Wi-Fi function.

Simultaneous transmitting consideration:

The ratio= $MPE_{BT}/limit + MPE_{2.4G\ Wi-Fi}/limit + MPE_{5G\ Wi-Fi}/limit = 0.0015/1 + 0.0329/1 + 0.0269/1 = 0.0613 < 1.0$

To maintain compliance with the FCC's RF exposure guidelines, place the equipment at least 20cm from nearby persons.

Result: Compliant.

FCC §15.203 – ANTENNA REQUIREMENT

Applicable Standard

According to § 15.203, an intentional radiator shall be designed to ensure that no antenna other than that furnished by the responsible party shall be used with the device. The use of a permanently attached antenna or of an antenna that uses a unique coupling to the intentional radiator shall be considered sufficient to comply with the provisions of this section. The manufacturer may design the unit so that a broken antenna can be replaced by the user, but the user of a standard antenna jack or electrical connector is prohibited. The structure and application of the EUT were analyzed to determine compliance with section §15.203 of the rules. §15.203 state that the subject device must meet the following criteria:

- a. Antenna must be permanently attached to the unit.
- b. Antenna must use a unique type of connector to attach to the EUT.

Unit must be professionally installed, and installer shall be responsible for verifying that the correct antenna is employed with the unit.

And according to FCC 47 CFR section 15.407 (a), if the transmitting antennas of directional gain greater than 6dBi are used, the transmit power and power spectral density shall be reduced by the amount in dB that the directional gain of the antenna exceeds 6 dBi.

Antenna Connector Construction

The EUT has two internal antennas used arrangement for Wi-Fi, which was permanently attached and the antenna gain is 2.85dBi (Ant0, Band 1), 4.31dBi (Ant0, Band 4), 3.47dBi (Ant1, Band 1) and 3.85dBi (Ant1, Band 4), fulfill the requirement of this section. Please refer to the EUT photos.

Result: Compliant.

FCC §15.407 (B) (8) §15.207 (A) – CONDUCTED EMISSIONS

Applicable Standard

FCC §15.207, §15.407(b) (8)

EUT Setup

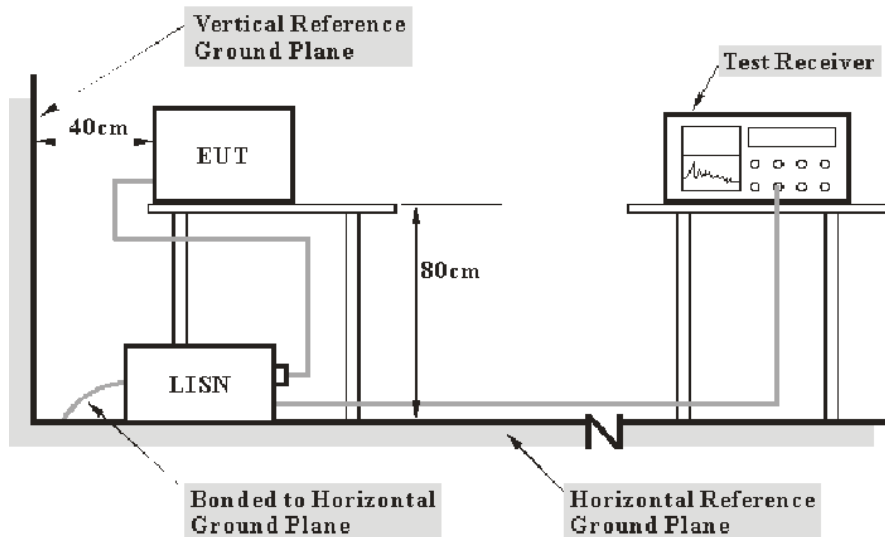

- Note: 1. Support units were connected to second LISN.
2. Both of LISNs (AMN) 80 cm from EUT and at the least 80 cm from other units and other metal planes support units.

The setup of EUT is according with per ANSI C63.10-2013 measurement procedure. The specification used was with the FCC Part 15.207 limits.

The spacing between the peripherals was 10 cm.

EMI Test Receiver Setup

The EMI test receiver was set to investigate the spectrum from 150 kHz to 30 MHz.

During the conducted emission test, the EMI test receiver was set with the following configurations:

Frequency Range	IF B/W
150 kHz – 30 MHz	9 kHz

Test Procedure

During the conducted emission test, the adapter was connected to the LISN.

Maximizing procedure was performed on the six (6) highest emissions of the EUT.

All data was recorded in the Quasi-peak and average detection mode.

Transd Factor & Margin Calculation

The Transd factor is calculated by adding LISN VDF (Voltage Division Factor) and Cable Loss. The basic equation is as follows:

$$\text{Transd Factor} = \text{LISN VDF} + \text{Cable Loss}$$

The “**Over limit**” column of the following data tables indicates the degree of compliance with the applicable limit. For example, an Over limit of -7 dB means the emission is 7 dB below the limit. The equation for calculation is as follows:

$$\begin{aligned}\text{Over Limit} &= \text{Level} - \text{Limit} \\ \text{Level} &= \text{Read Level} + \text{Factor}\end{aligned}$$

Test Data**Environmental Conditions**

Temperature:	25 °C
Relative Humidity:	64 %
ATM Pressure:	101.0 kPa

The testing was performed by Bin Duan on 2021-11-23.

EUT operation mode: 5G Wi-Fi Transmitting (Worst case as below)

Adapter 1:
AC 120V/60 Hz, Line

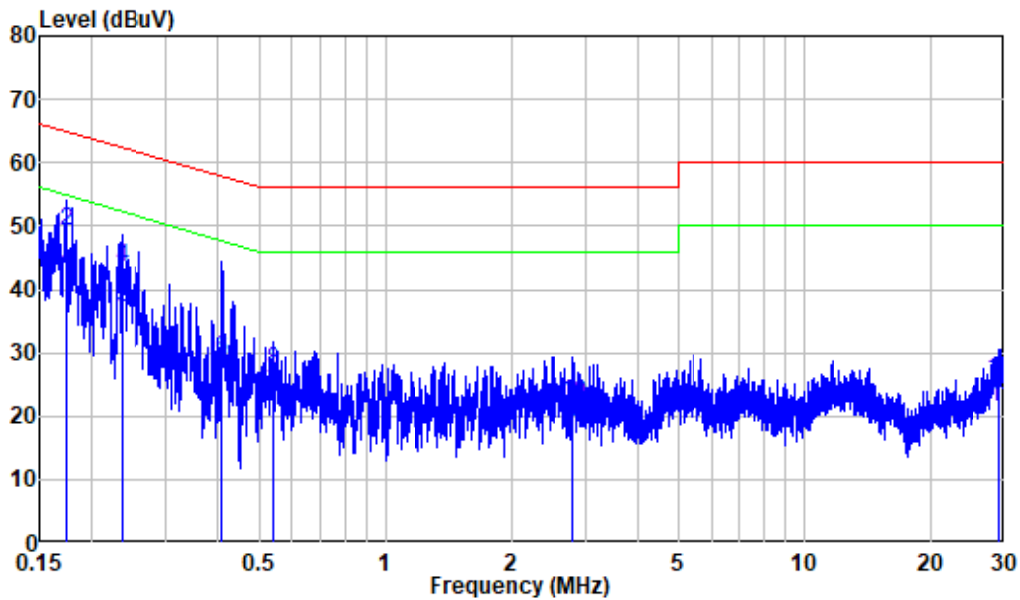

Site : Shielding Room
 Condition: Line
 Mode : 5G WIFI Transmitting

	Freq	Factor	Read Level	Level	Limit	Over	Remark
	MHz	dB	dBuV	dBuV	dBuV	dB	
1	0.173	9.85	32.45	42.30	54.80	-12.50	Average
2	0.173	9.85	39.29	49.14	64.80	-15.66	QP
3	0.235	9.80	27.29	37.09	52.29	-15.20	Average
4	0.235	9.80	33.70	43.50	62.29	-18.79	QP
5	0.408	9.80	16.86	26.66	47.68	-21.02	Average
6	0.408	9.80	19.21	29.01	57.68	-28.67	QP
7	0.539	9.81	13.80	23.61	46.00	-22.39	Average
8	0.539	9.81	17.41	27.22	56.00	-28.78	QP
9	2.800	9.93	8.96	18.89	46.00	-27.11	Average
10	2.800	9.93	12.01	21.94	56.00	-34.06	QP
11	29.158	10.48	10.92	21.40	50.00	-28.60	Average
12	29.158	10.48	15.25	25.73	60.00	-34.27	QP

AC 120V/60 Hz, Neutral

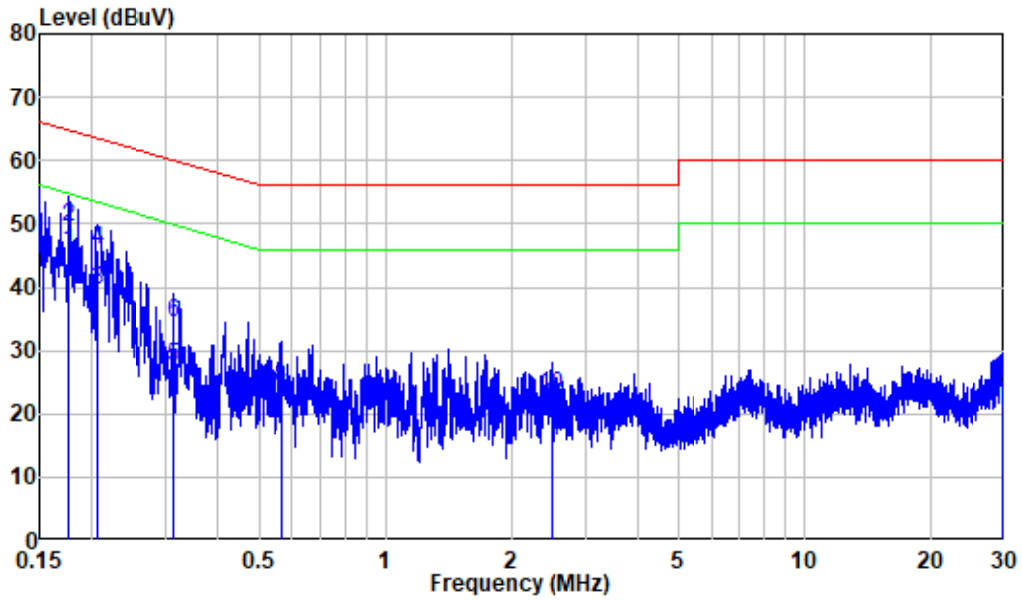

Site : Shielding Room
 Condition: Neutral
 Mode : 5G WIFI Transmitting

	Freq	Factor	Read Level	Level	Limit Line	Over Limit	Remark
	MHz	dB	dBuV	dBuV	dBuV	dB	
1	0.176	9.96	35.49	45.45	54.67	-9.22	Average
2	0.176	9.96	39.46	49.42	64.67	-15.25	QP
3	0.205	10.00	29.56	39.56	53.39	-13.83	Average
4	0.205	10.00	35.96	45.96	63.39	-17.43	QP
5	0.312	9.95	17.61	27.56	49.92	-22.36	Average
6	0.312	9.95	24.49	34.44	59.92	-25.48	QP
7	0.566	9.91	12.65	22.56	46.00	-23.44	Average
8	0.566	9.91	14.17	24.08	56.00	-31.92	QP
9	2.485	9.95	11.38	21.33	46.00	-24.67	Average
10	2.485	9.95	13.08	23.03	56.00	-32.97	QP
11	29.703	10.40	10.06	20.46	50.00	-29.54	Average
12	29.703	10.40	14.87	25.27	60.00	-34.73	QP

Adapter 2:
AC 120V/60 Hz, Line

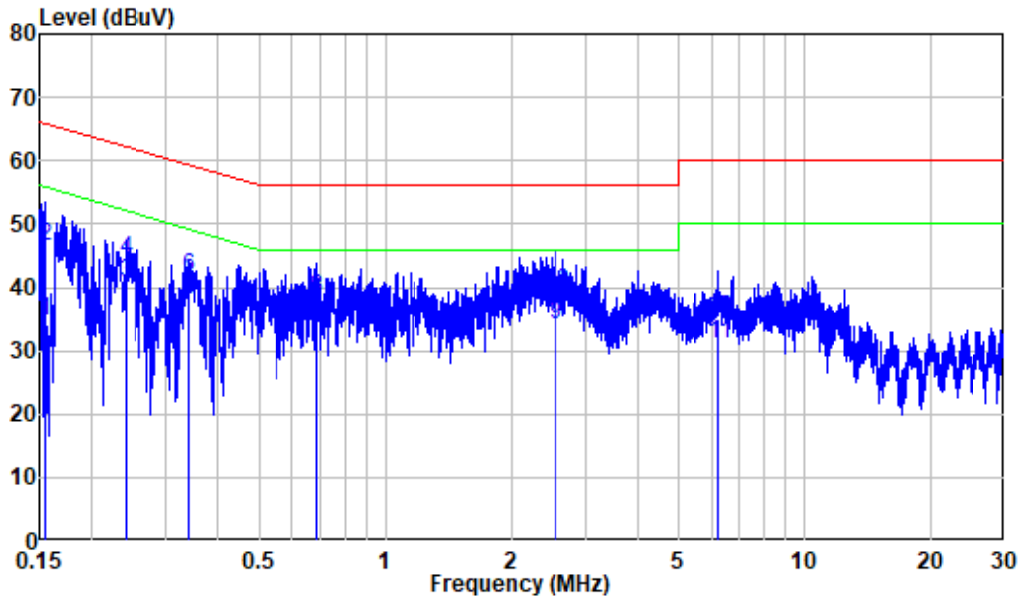

Site : Shielding Room
 Condition: Line
 Mode : 5G WIFI Transmitting

	Freq	Factor	Read Level	Level	Limit Line	Over Limit	Remark
	MHz	dB	dBuV	dBuV	dBuV	dB	
1	0.155	9.89	24.81	34.70	55.73	-21.03	Average
2	0.155	9.89	36.46	46.35	65.73	-19.38	QP
3	0.240	9.80	30.95	40.75	52.09	-11.34	Average
4	0.240	9.80	34.60	44.40	62.09	-17.69	QP
5	0.341	9.80	28.35	38.15	49.18	-11.03	Average
6	0.341	9.80	32.00	41.80	59.18	-17.38	QP
7	0.685	9.81	22.80	32.61	46.00	-13.39	Average
8	0.685	9.81	28.40	38.21	56.00	-17.79	QP
9	2.557	9.93	24.29	34.22	46.00	-11.78	Average
10	2.557	9.93	29.27	39.20	56.00	-16.80	QP
11	6.240	10.04	21.13	31.17	50.00	-18.83	Average
12	6.240	10.04	25.06	35.10	60.00	-24.90	QP

AC 120V/60 Hz, Neutral

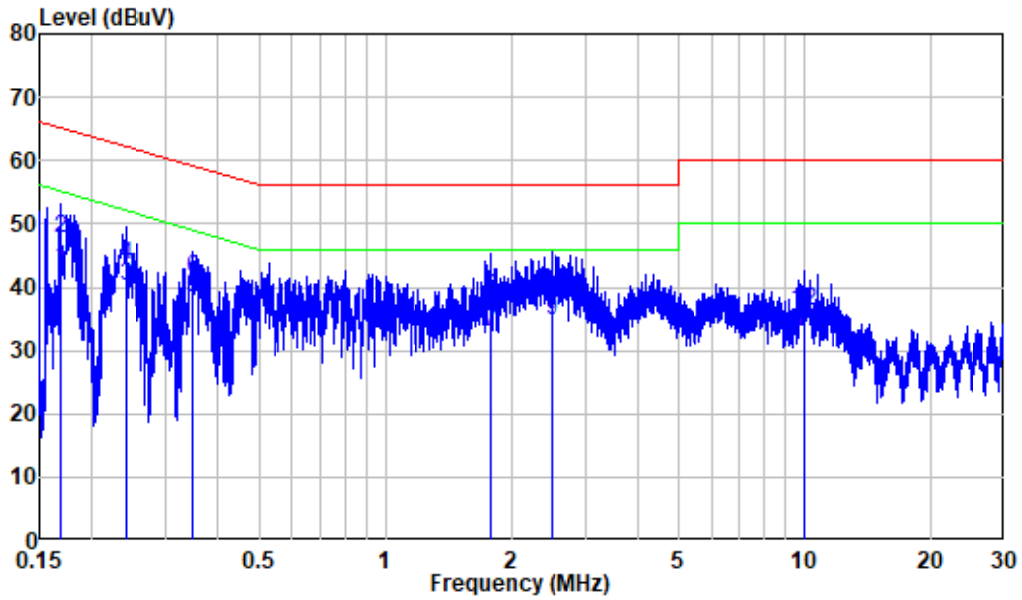

Site : Shielding Room
 Condition: Neutral
 Mode : 5G WIFI Transmitting

	Freq	Factor	Read Level	Level	Limit Line	Over Limit	Remark
	MHz	dB	dBuV	dBuV	dBuV	dB	
1	0.169	9.94	32.90	42.84	55.02	-12.18	Average
2	0.169	9.94	37.78	47.72	65.02	-17.30	QP
3	0.240	9.98	30.08	40.06	52.11	-12.05	Average
4	0.240	9.98	33.39	43.37	62.11	-18.74	QP
5	0.348	9.94	28.44	38.38	49.01	-10.63	Average
6	0.348	9.94	31.43	41.37	59.01	-17.64	QP
7	1.789	9.92	22.84	32.76	46.00	-13.24	Average
8	1.789	9.92	28.52	38.44	56.00	-17.56	QP
9	2.498	9.95	24.81	34.76	46.00	-11.24	Average
10	2.498	9.95	29.42	39.37	56.00	-16.63	QP
11	9.920	10.10	22.72	32.82	50.00	-17.18	Average
12	9.920	10.10	26.06	36.16	60.00	-23.84	QP

Adapter 3:
AC 120V/60 Hz, Line

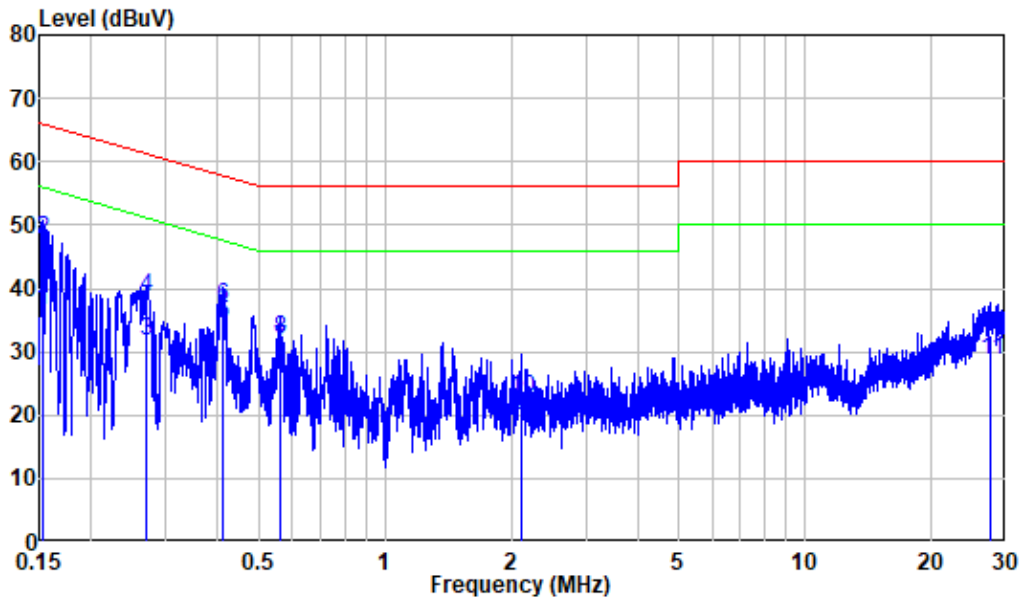

Site : Shielding Room
 Condition: Line
 Mode : 5G WIFI Transmitting

	Freq	Factor	Read Level	Limit Level	Limit Line	Over Limit	Remark
	MHz	dB	dBUV	dBUV	dBUV	dB	
1	0.153	9.89	26.51	36.40	55.86	-19.46	Average
2	0.153	9.89	37.84	47.73	65.86	-18.13	QP
3	0.270	9.80	21.82	31.62	51.10	-19.48	Average
4	0.270	9.80	28.85	38.65	61.10	-22.45	QP
5	0.412	9.80	24.51	34.31	47.61	-13.30	Average
6	0.412	9.80	27.38	37.18	57.61	-20.43	QP
7	0.560	9.81	20.74	30.55	46.00	-15.45	Average
8	0.560	9.81	22.24	32.05	56.00	-23.95	QP
9	2.109	9.92	9.95	19.87	46.00	-26.13	Average
10	2.109	9.92	12.72	22.64	56.00	-33.36	QP
11	27.708	10.44	18.12	28.56	50.00	-21.44	Average
12	27.708	10.44	22.03	32.47	60.00	-27.53	QP

AC 120V/60 Hz, Neutral

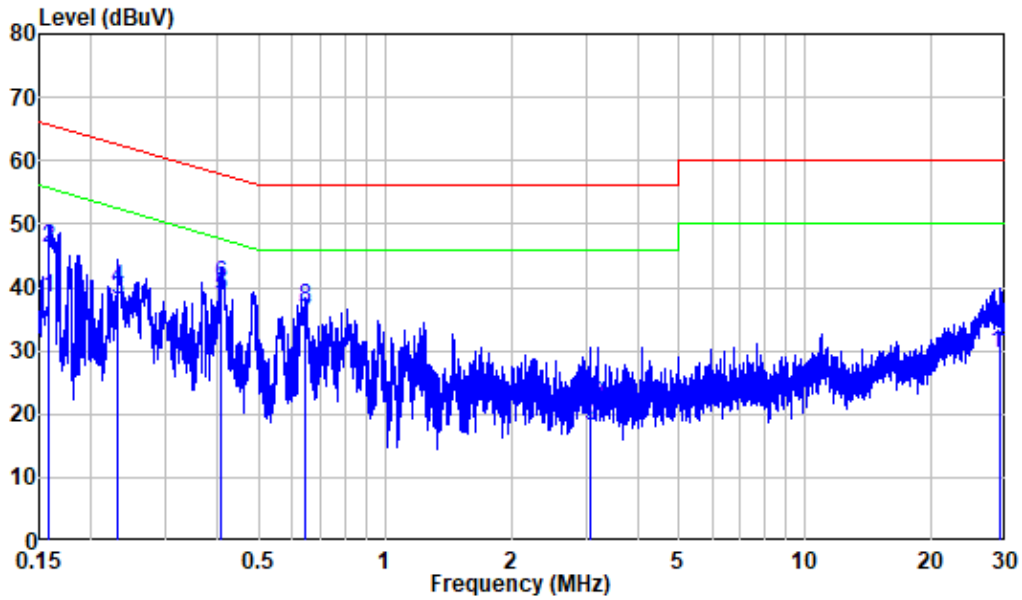

Site : Shielding Room
 Condition: Neutral
 Mode : 5G WIFI Transmitting

	Freq	Factor	Read Level	Limit Level	Limit Line	Over Limit	Remark
	MHz	dB	dBuV	dBuV	dBuV	dB	
1	0.159	9.92	28.49	38.41	55.52	-17.11	Average
2	0.159	9.92	36.37	46.29	65.52	-19.23	QP
3	0.232	9.98	27.93	37.91	52.39	-14.48	Average
4	0.232	9.98	29.92	39.90	62.39	-22.49	QP
5	0.407	9.92	28.81	38.73	47.70	-8.97	Average
6	0.407	9.92	30.49	40.41	57.70	-17.29	QP
7	0.645	9.91	24.44	34.35	46.00	-11.65	Average
8	0.645	9.91	26.86	36.77	56.00	-19.23	QP
9	3.090	9.99	8.23	18.22	46.00	-27.78	Average
10	3.090	9.99	11.58	21.57	56.00	-34.43	QP
11	29.216	10.38	19.24	29.62	50.00	-20.38	Average
12	29.216	10.38	22.84	33.22	60.00	-26.78	QP

Adapter 4:
AC 120V/60 Hz, Line

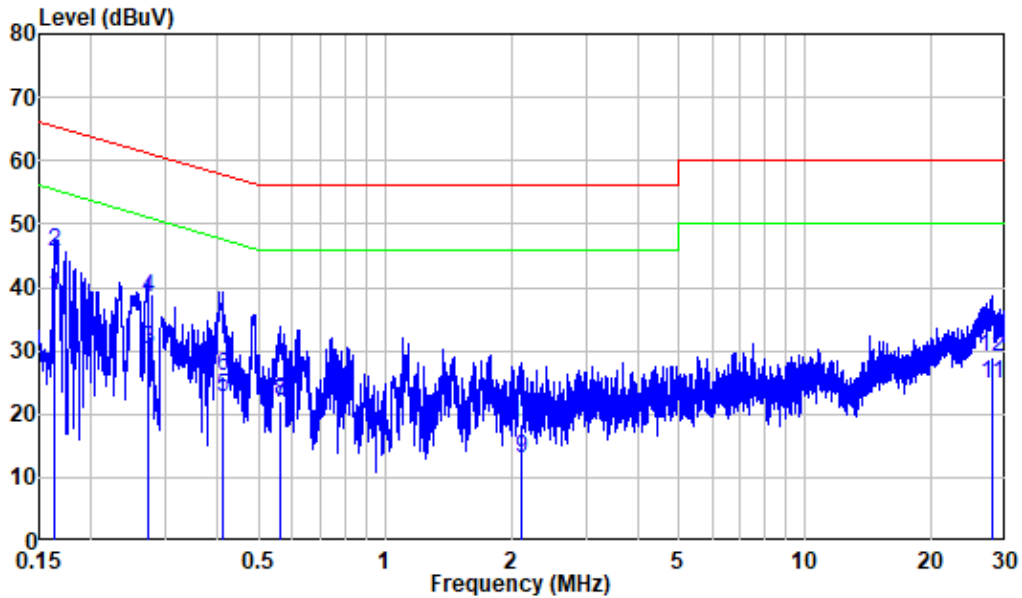

Site : Shielding Room
 Condition: Line
 Mode : 5G WIFI Transmitting

	Freq	Factor	Read Level	Level	Limit Line	Over Limit	Remark
	MHz	dB	dBuV	dBuV	dBuV	dB	
1	0.164	9.87	28.83	38.70	55.28	-16.58	Average
2	0.164	9.87	35.76	45.63	65.28	-19.65	QP
3	0.272	9.80	20.46	30.26	51.05	-20.79	Average
4	0.272	9.80	28.44	38.24	61.05	-22.81	QP
5	0.412	9.80	12.98	22.78	47.62	-24.84	Average
6	0.412	9.80	16.31	26.11	57.62	-31.51	QP
7	0.560	9.81	11.90	21.71	46.00	-24.29	Average
8	0.560	9.81	12.28	22.09	56.00	-33.91	QP
9	2.102	9.92	3.16	13.08	46.00	-32.92	Average
10	2.102	9.92	8.54	18.46	56.00	-37.54	QP
11	27.745	10.44	14.31	24.75	50.00	-25.25	Average
12	27.745	10.44	18.69	29.13	60.00	-30.87	QP

AC 120V/60 Hz, Neutral

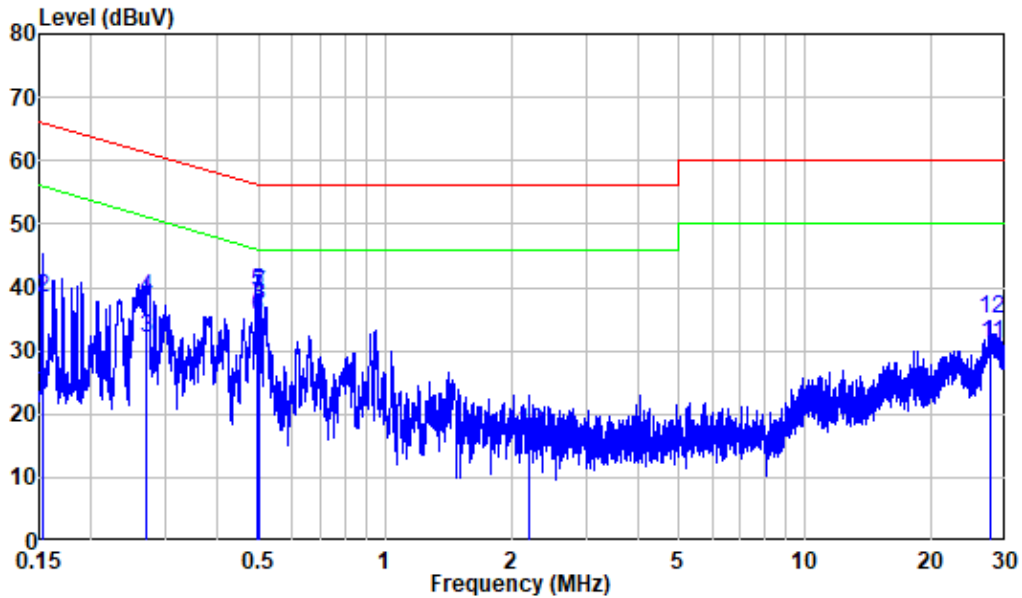

Site : Shielding Room
 Condition: Neutral
 Mode : 5G WIFI Transmitting

	Freq	Factor	Read Level	Level	Limit Line	Over Limit	Remark
	MHz	dB	dBuV	dBuV	dBuV	dB	
1	0.153	9.91	13.70	23.61	55.85	-32.24	Average
2	0.153	9.91	28.53	38.44	65.85	-27.41	QP
3	0.271	9.97	21.98	31.95	51.09	-19.14	Average
4	0.271	9.97	28.24	38.21	61.09	-22.88	QP
5	0.498	9.90	29.39	39.29	46.03	-6.74	Average
6	0.498	9.90	25.40	35.30	56.03	-20.73	QP
7	0.501	9.90	29.00	38.90	46.00	-7.10	Average
8	0.501	9.90	27.13	37.03	56.00	-18.97	QP
9	2.206	9.93	5.86	15.79	46.00	-30.21	Average
10	2.206	9.93	7.16	17.09	56.00	-38.91	QP
11	27.726	10.36	20.65	31.01	50.00	-18.99	Average
12	27.726	10.36	24.80	35.16	60.00	-24.84	QP

§15.205 & §15.209 & §15.407(B) (1), (4), (7), (8), (9), (10) – UNDESIRABLE EMISSION

Applicable Standard

FCC §15.407 (b) (1), (4), (7), (8), (9), (10); §15.209; §15.205;

(b) Undesirable emission limits. Except as shown in paragraph (b) (7) of this section, the maximum emissions outside of the frequency bands of operation shall be attenuated in accordance with the following limits:

- (1) For transmitters operating in the 5.15-5.25 GHz band: All emissions outside of the 5.15-5.35 GHz band shall not exceed an e.i.r.p. of -27 dBm/MHz.
- (4) For transmitters operating in the 5.725-5.85 GHz band:
- (i) All emissions shall be limited to a level of -27 dBm/MHz at 75 MHz or more above or below the band edge increasing linearly to 10 dBm/MHz at 25 MHz above or below the band edge, and from 25 MHz above or below the band edge increasing linearly to a level of 15.6 dBm/MHz at 5 MHz above or below the band edge, and from 5 MHz above or below the band edge increasing linearly to a level of 27 dBm/MHz at the band edge.

Unwanted emissions below 1 GHz must comply with the general field strength limits set forth in §15.209.

EUT Setup

Below 1 GHz:

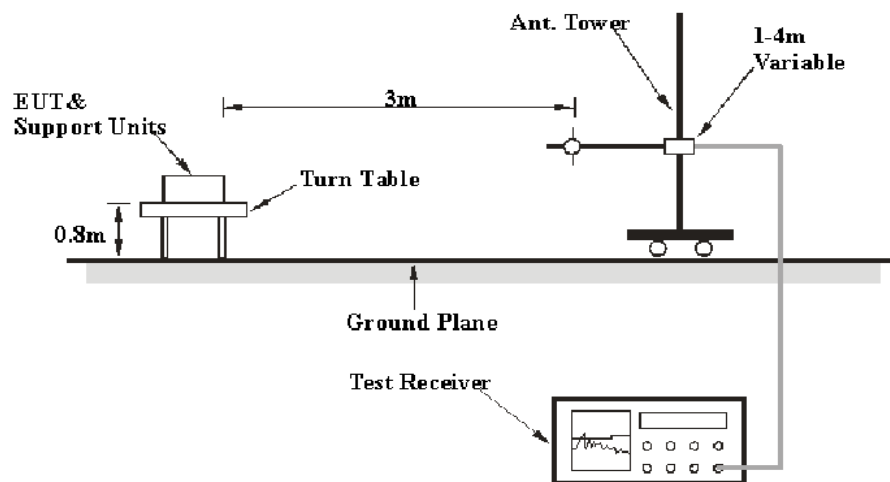

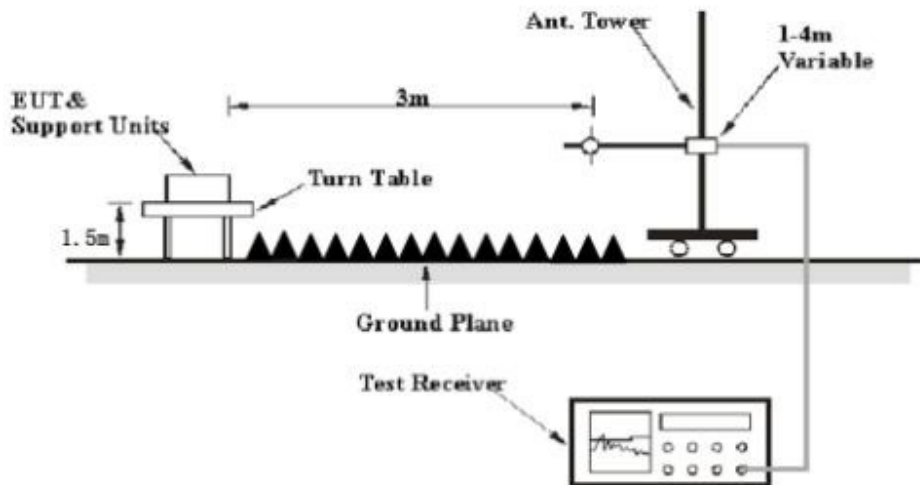
Above 1 GHz:

The setup of EUT is according with per ANSI C63.10-2013 measurement procedure. The specification used was with the FCC 15.209 and FCC 15.407 limits.

EMI Test Receiver & Spectrum Analyzer Setup

During the radiated emission test, the EMI test receiver & Spectrum Analyzer Setup were set with the following configurations:

Frequency Range	RBW	Video B/W	IF B/W	Measurement
30 MHz – 1000 MHz	100 kHz	300 kHz	120 kHz	QP
Above 1 GHz	1 MHz	3 MHz	/	PK
	1MHz	10 Hz ^{Note 1}	/	Average
	1MHz	> 1/T ^{Note 2}	/	Average

Note 1: when duty cycle is no less than 98%

Note 2: when duty cycle is less than 98%

Test Procedure**Radiated Spurious Emission**

Maximizing procedure was performed on the highest emissions to ensure that the EUT complied with all the installation combinations.

Factor & Margin Calculation

The Factor is calculated by adding the Antenna Factor and Cable Loss, and subtracting the Amplifier Gain. The basic equation is as follows:

$$\text{Factor} = \text{Antenna Factor} + \text{Cable Loss} - \text{Amplifier Gain}$$

The “**Over Limit/Margin**” column of the following data tables indicates the degree of compliance with the applicable limit. For example, an Over Limit/margin of -7dB means the emission is 7dB below the limit. The equation for calculation is as follows:

$$\begin{aligned} \text{Over Limit/Margin} &= \text{Level} / \text{Corrected Amplitude} - \text{Limit} \\ \text{Level} / \text{Corrected Amplitude} &= \text{Read Level} + \text{Factor} \end{aligned}$$

Test Data

Environmental Conditions

Temperature:	25 °C
Relative Humidity:	50-64 %
ATM Pressure:	101.0-103.0 kPa

The testing was performed by Chao Mo on 2021-11-16 for below 1GHz, from 2021-11-16 to 2021-11-20 for above 1GHz.

EUT operation mode: Transmitting

(Scan with 802.11a/n20/n40/ac20/ac40/ac80 modes, the worst case as below)

30 MHz~1 GHz:(worst case for 802.11ac40, 5230MHz)

Adapter 1:

Horizontal:

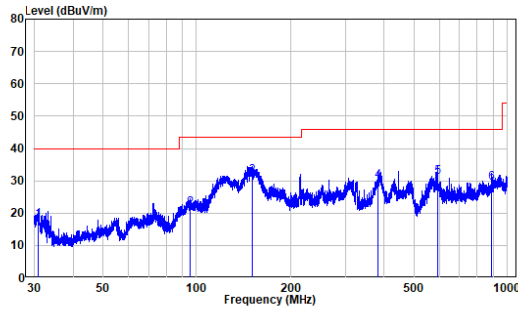

Site : chamber
 Condition: 3m HORIZONTAL
 Job No. : SZNS1211111-58026E-RF
 Test Mode: 5G WIFI Transmitting

	Freq Factor		Read Level		Limit		Over Limit	Remark
	MHz	dB/m	dBuV	dBuV/m	dBuV/m	dB		
1	31.03	-20.32	38.08	17.76	40.00	-22.24	QP	
2	95.30	-20.15	41.44	21.29	43.50	-22.21	QP	
3	150.34	-21.59	53.03	31.44	43.50	-12.06	QP	
4	382.59	-15.73	45.50	29.77	46.00	-16.23	QP	
5	593.31	-10.93	42.16	31.23	46.00	-14.77	QP	
6	890.34	-8.52	37.71	29.19	46.00	-16.81	QP	

Vertical

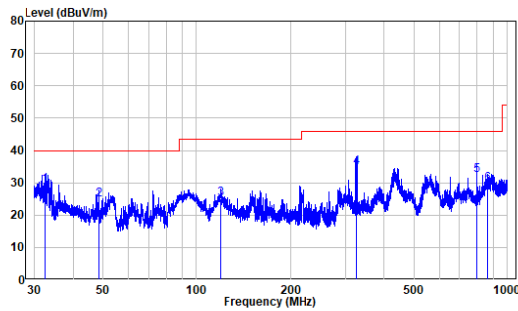

Site : chamber
 Condition: 3m VERTICAL
 Job No. : SZNS1211111-58026E-RF
 Test Mode: 5G WIFI Transmitting

	Freq Factor		Read Level		Limit		Over Limit	Remark
	MHz	dB/m	dBuV	dBuV/m	dBuV/m	dB		
1	32.51	-20.00	49.36	29.36	40.00	-10.64	QP	
2	48.44	-17.30	41.99	24.69	40.00	-15.31	QP	
3	119.70	-20.37	45.44	25.07	43.50	-18.43	QP	
4	325.45	-16.77	51.62	34.85	46.00	-11.15	QP	
5	800.03	-11.52	43.94	32.42	46.00	-13.58	QP	
6	865.33	-9.30	38.94	29.64	46.00	-16.36	QP	

Adapter 2:

Horizontal:

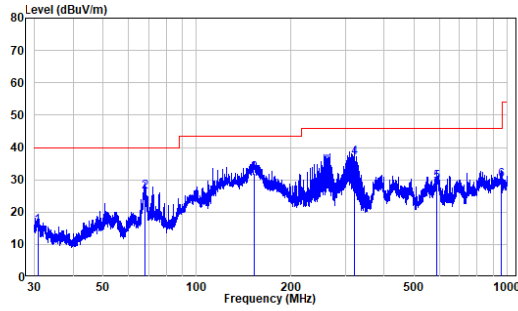

Site : chamber
 Condition: 3m HORIZONTAL
 Job No. : SZNS1211111-58026E-RF
 Test Mode: 5G WIFI Transmitting

	Freq	Factor	Read		Limit	Over	Remark
			Level	Level			
	MHz	dB/m	dBuV	dBuV/m	dBuV/m	dB	
1	30.84	-20.37	35.96	15.59	40.00	-24.41	QP
2	68.00	-20.94	47.17	26.23	40.00	-13.77	QP
3	152.53	-21.62	53.77	32.15	43.50	-11.35	QP
4	321.62	-16.76	53.72	36.96	46.00	-9.04	QP
5	589.68	-11.01	40.41	29.40	46.00	-16.60	QP
6	958.79	-8.00	37.83	29.83	46.00	-16.17	QP

Vertical

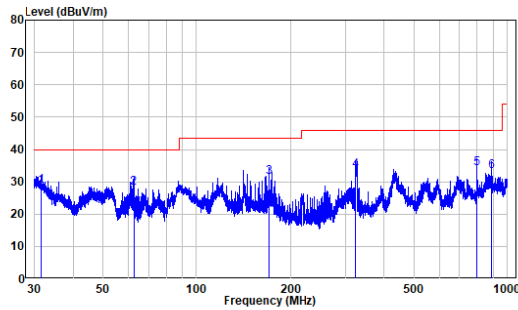

Site : chamber
 Condition: 3m VERTICAL
 Job No. : SZNS1211111-58026E-RF
 Test Mode: 5G WIFI Transmitting

	Freq	Factor	Read		Limit	Over	Remark
			Level	Level			
	MHz	dB/m	dBuV	dBuV/m	dBuV/m	dB	
1	31.68	-20.18	48.85	28.67	40.00	-11.33	QP
2	62.57	-19.98	45.18	25.20	40.00	-11.80	QP
3	169.97	-20.97	52.28	31.31	43.50	-12.19	QP
4	324.46	-16.78	50.16	33.38	46.00	-12.62	QP
5	800.03	-11.52	45.61	34.09	46.00	-11.91	QP
6	890.34	-8.52	41.59	33.07	46.00	-12.93	QP

Adapter 3:

Horizontal:

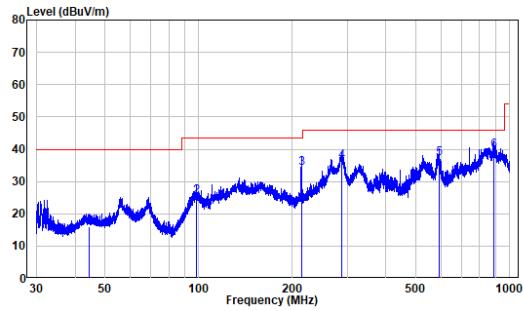

Site : chamber
 Condition: 3m HORIZONTAL
 Job No. : SZNS1211111-58026E-RF
 Test Mode: 5G WIFI Transmitting

	Freq	Factor	Read Level	Level	Limit Line	Over Limit	Remark
	MHz	dB/m	dBuV	dBuV/m	dBuV/m	dB	
1	44.26	-9.91	25.96	16.05	40.00	-23.95	QP
2	98.27	-12.19	37.41	25.22	43.50	-18.28	QP
3	213.86	-11.72	45.89	34.17	43.50	-9.33	QP
4	287.86	-9.36	45.56	36.20	46.00	-9.80	QP
5	591.49	-2.72	39.88	37.16	46.00	-8.84	QP
6	890.34	0.94	38.51	39.45	46.00	-6.55	QP

Vertical

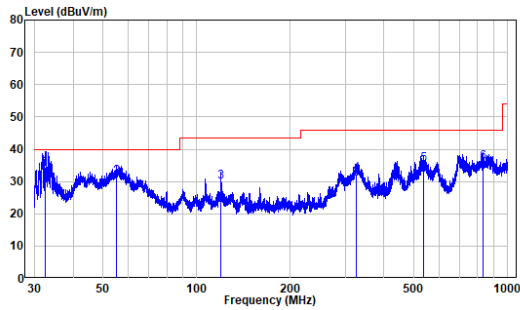

Site : chamber
 Condition: 3m VERTICAL
 Job No. : SZNS1211111-58026E-RF
 Test Mode: 5G WIFI Transmitting

	Freq	Factor	Read Level	Level	Limit Line	Over Limit	Remark
	MHz	dB/m	dBuV	dBuV/m	dBuV/m	dB	
1	32.63	-12.07	46.60	34.53	40.00	-5.47	QP
2	55.27	-10.26	41.80	31.54	40.00	-8.46	QP
3	119.23	-13.39	43.20	29.81	43.50	-13.69	QP
4	325.17	-8.26	40.63	32.37	46.00	-13.63	QP
5	534.77	-4.43	39.68	35.25	46.00	-10.75	QP
6	832.95	0.13	35.87	36.00	46.00	-10.00	QP

Adapter 4:

Horizontal:

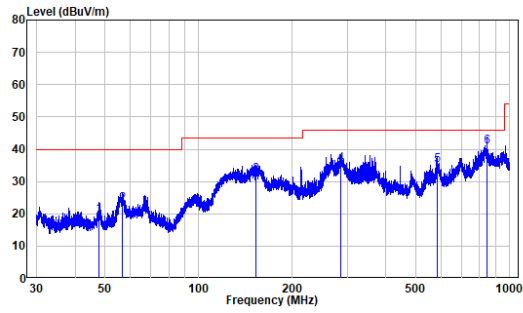

Site : chamber
 Condition: 3m HORIZONTAL
 Job No. : SZNS1211111-58026E-RF
 Test Mode: 5G WIFI Transmitting

	Freq	Factor	Read Level	Level	Limit Line	Over Limit	Remark
	MHz	dB/m	dBuV	dBuV/m	dBuV/m	dB	
1	47.85	-10.00	29.62	19.62	40.00	-20.38	QP
2	56.72	-10.09	33.00	22.91	40.00	-17.09	QP
3	152.40	-15.14	47.05	31.91	43.50	-11.59	QP
4	286.73	-9.40	44.61	35.21	46.00	-10.79	QP
5	586.07	-2.95	37.85	34.90	46.00	-11.10	QP
6	845.09	0.42	40.38	40.80	46.00	-5.20	QP

Vertical

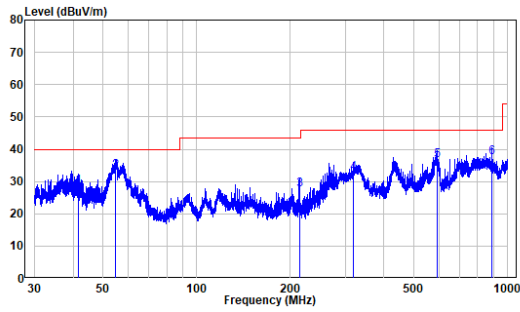

Site : chamber
 Condition: 3m VERTICAL
 Job No. : SZNS1211111-58026E-RF
 Test Mode: 5G WIFI Transmitting

	Freq	Factor	Read Level	Level	Limit Line	Over Limit	Remark
	MHz	dB/m	dBuV	dBuV/m	dBuV/m	dB	
1	41.48	-10.11	38.51	28.40	40.00	-11.60	QP
2	54.79	-10.29	43.53	33.24	40.00	-6.76	QP
3	213.67	-11.73	39.28	27.55	43.50	-15.95	QP
4	319.38	-8.48	41.20	32.72	46.00	-13.28	QP
5	592.79	-2.72	39.28	36.56	46.00	-9.44	QP
6	890.34	0.94	36.54	37.48	46.00	-8.52	QP

2TX Mode (Worst case)**1 ~ 40 GHz:****Band 1: (5150-5250MHz)**

Frequency (MHz)	Receiver		Turntable Degree	Rx Antenna		Corrected Factor (dB/m)	Corrected Amplitude (dBμV/m)	Limit (dBμV/m)	Margin (dB)
	Reading (dBuV)	PK/QP/AV		Height (m)	Polar (H/V)				
Band1 802.11 A Low Channel (5180 MHz)									
4500	54.86	PK	10	2	H	-4.72	50.14	74	-23.86
4500	57.37	PK	198	1.8	V	-4.72	52.65	74	-21.35
5150	54.6	PK	207	1.4	H	-2.73	51.87	74	-22.13
5150	56.05	PK	338	2.4	V	-2.73	53.32	74	-20.68
10360	33.54	PK	284	1.4	H	8.12	41.66	68.2	-26.54
10360	33.7	PK	345	2	V	8.12	41.82	68.2	-26.38
Band1 802.11 A Middle Channel (5200 MHz)									
10400	34.2	PK	110	2.2	H	8.24	42.44	68.2	-25.76
10400	33.82	PK	360	2.3	V	8.24	42.06	68.2	-26.14
Band1 802.11 A High Channel (5240 MHz)									
5350	53.2	PK	289	1.5	H	-2.33	50.87	74	-23.13
5350	52.59	PK	153	1.2	V	-2.33	50.26	74	-23.74
5460	51.73	PK	102	1.8	H	-2.26	49.47	74	-24.53
5460	54.93	PK	250	1.1	V	-2.26	52.67	74	-21.33
10480	36.22	PK	135	1.8	H	8.57	44.79	68.2	-23.41
10480	36.55	PK	97	1.9	V	8.57	45.12	68.2	-23.08
Band1 802.11 N20 Low Channel (5180 MHz)									
4500	53.86	PK	95	2.3	H	-4.72	49.14	74	-24.86
4500	55.06	PK	151	1.6	V	-4.72	50.34	74	-23.66
5150	55.11	PK	330	1.9	H	-2.73	52.38	74	-21.62
5150	55.76	PK	53	2.1	V	-2.73	53.03	74	-20.97
10360	33.75	PK	37	2.4	H	8.12	41.87	68.2	-26.33
10360	34.11	PK	6	1.7	V	8.12	42.23	68.2	-25.97
Band1 802.11 N20 Middle Channel (5200 MHz)									
10400	33.23	PK	56	1.2	H	8.24	41.47	68.2	-26.73
10400	33.84	PK	105	2.5	V	8.24	42.08	68.2	-26.12
Band1 802.11 N20 High Channel (5240 MHz)									
5350	53.79	PK	85	1.8	H	-2.33	51.46	74	-22.54
5350	52.72	PK	326	1.8	V	-2.33	50.39	74	-23.61
5460	51.92	PK	49	2	H	-2.26	49.66	74	-24.34
5460	53.16	PK	47	1.7	V	-2.26	50.9	74	-23.1
10480	33.86	PK	337	2.2	H	8.57	42.43	68.2	-25.77
10480	33.62	PK	185	1.2	V	8.57	42.19	68.2	-26.01
Band1 802.11 N40 Low Channel (5190 MHz)									
4500	52.47	PK	115	2.1	H	-2.33	50.14	74	-23.86
4500	53.32	PK	72	1.6	V	-2.33	50.99	74	-23.01
5150	54.95	PK	297	2.4	H	-2.26	52.69	74	-21.31
5150	55.9	PK	54	2.5	V	-2.26	53.64	74	-20.36

10380	43.13	PK	129	2.4	H	8.19	51.32	68.2	-16.88
10380	44.38	PK	153	2.1	V	8.19	52.57	68.2	-15.63
Band1 802.11 N40 High Channel (5230 MHz)									
5350	56.22	PK	23	1.3	H	-2.33	53.89	74	-20.11
5350	55.49	PK	24	1.4	V	-2.33	53.16	74	-20.84
5460	54.62	PK	12	1.8	H	-2.26	52.36	74	-21.64
5460	55.81	PK	348	2.1	V	-2.26	53.55	74	-20.45
10460	42.83	PK	229	2.1	H	8.48	51.31	68.2	-16.89
10460	43.16	PK	3	1	V	8.48	51.64	68.2	-16.56
Band1 802.11 AC20 Low Channel (5180 MHz)									
4500	55.63	PK	306	1.1	H	-4.72	50.91	74	-23.09
4500	56.54	PK	113	2.3	V	-4.72	51.82	74	-22.18
5150	53.36	PK	246	1.7	H	-2.73	50.63	74	-23.37
5150	55.64	PK	191	1.3	V	-2.73	52.91	74	-21.09
10360	42.72	PK	108	1.7	H	8.12	50.84	68.2	-17.36
10360	43.34	PK	307	1.3	V	8.12	51.46	68.2	-16.74
Band1 802.11 AC20 Middle Channel (5200 MHz)									
10400	34.62	PK	154	1	H	8.24	42.86	68.2	-25.34
10400	35.76	PK	142	2	V	8.24	44	68.2	-24.2
Band1 802.11 AC20 High Channel (5240 MHz)									
5350	51.97	PK	288	1.5	H	-2.33	49.64	74	-24.36
5350	52.56	PK	284	2.2	V	-2.33	50.23	74	-23.77
5460	52.8	PK	30	1.4	H	-2.26	50.54	74	-23.46
5460	51.9	PK	318	2.4	V	-2.26	49.64	74	-24.36
10480	33.25	PK	359	1.6	H	8.57	41.82	68.2	-26.38
10480	34.24	PK	144	2.4	V	8.57	42.81	68.2	-25.39
Band1 802.11 AC40 Low Channel (5190 MHz)									
4500	53.48	PK	94	1.5	H	-2.33	51.15	74	-22.85
4500	52.87	PK	103	1.2	V	-2.33	50.54	74	-23.46
5150	55.17	PK	331	1.7	H	-2.26	52.91	74	-21.09
5150	55.77	PK	118	1	V	-2.26	53.51	74	-20.49
10380	43.12	PK	290	1.9	H	8.19	51.31	68.2	-16.89
10380	44.13	PK	123	1.2	V	8.19	52.32	68.2	-15.88
Band1 802.11 AC40 High Channel (5230 MHz)									
5350	52.67	PK	180	1.4	H	-2.33	50.34	74	-23.66
5350	54.19	PK	278	2.3	V	-2.33	51.86	74	-22.14
5460	55.85	PK	149	1.4	H	-2.26	53.59	74	-20.41
5460	55.37	PK	265	1.1	V	-2.26	53.11	74	-20.89
10460	44.96	PK	54	2.4	H	8.48	53.44	68.2	-14.76
10460	43.34	PK	321	1.8	V	8.48	51.82	68.2	-16.38
Band1 802.11 AC80 (5210 MHz)									
4500	51.97	PK	153	2.5	H	-2.33	49.64	74	-24.36
4500	52.47	PK	8	1.8	V	-2.33	50.14	74	-23.86
5150	56.12	PK	213	1.5	H	-2.26	53.86	74	-20.14
5150	55.57	PK	184	1.5	V	-2.26	53.31	74	-20.69
5350	53.66	PK	265	1.6	H	-2.33	51.33	74	-22.67
5350	53.18	PK	321	2.4	V	-2.33	50.85	74	-23.15

5460	52.83	PK	208	1.3	H	-2.26	50.57	74	-23.43
5460	52.48	PK	4	1.4	V	-2.26	50.22	74	-23.78
10420	43.85	PK	302	2.3	H	8.31	52.16	68.2	-16.04
10420	43.65	PK	188	1.9	V	8.31	51.96	68.2	-16.24

Band 4:(5725-5850MHz)

Frequency (MHz)	Receiver		Turntable Degree	Rx Antenna		Corrected Factor (dB/m)	Corrected Amplitude (dB μ V/m)	Limit (dB μ V/m)	Margin (dB)
	Reading (dBuV)	PK/QP/AV		Height (m)	Polar (H/V)				
802.11A BAND4 5745, Low Channel									
5725	44.81	PK	354	1.7	H	-1.96	42.85	122.2	-79.35
5725	45.48	PK	160	1.8	V	-1.96	43.52	122.2	-78.68
5720	46.08	PK	252	1.3	H	-1.96	44.12	110.8	-66.68
5720	47.34	PK	103	1.5	V	-1.96	45.38	110.8	-65.42
5700	46.65	PK	43	1.4	H	-2.02	44.63	105.2	-60.57
5700	47.84	PK	326	2.1	V	-2.02	45.82	105.2	-59.38
5650	46.14	PK	24	1.2	H	-1.95	44.19	68.2	-24.01
5650	45.60	PK	190	1.4	V	-1.95	43.65	68.2	-24.55
11490	34.96	PK	167	1.6	H	6.63	41.59	74	-32.41
11490	35.85	PK	146	1.8	V	6.63	42.48	74	-31.52
802.11A BAND4 5785, Middle Channel									
11570	33.60	PK	154	1.9	H	6.59	40.19	74	-33.81
11570	35.73	PK	61	1.6	V	6.59	42.32	74	-31.68
802.11A BAND4 5825, High Channel									
5850	46.52	PK	120	1.7	H	-1.81	44.71	122.2	-77.49
5850	49.91	PK	342	1.5	V	-1.81	48.10	122.2	-74.1
5855	44.46	PK	60	1.4	H	-1.82	42.64	110.8	-68.16
5855	49.15	PK	212	1.1	V	-1.82	47.33	110.8	-63.47
5875	47.17	PK	92	1.5	H	-1.84	45.33	105.2	-59.87
5875	48.65	PK	66	1.2	V	-1.84	46.81	105.2	-58.39
5925	43.09	PK	183	1	H	-1.83	41.26	68.2	-26.94
5925	42.94	PK	220	1.5	V	-1.83	41.11	68.2	-27.09
11650	34.76	PK	13	1.6	H	6.77	41.53	74	-32.47
11650	33.38	PK	348	1.8	V	6.77	40.15	74	-33.85
802.11N20 BAND4, Low Channel									
5725	47.04	PK	116	1.8	H	-1.96	45.08	122.2	-77.12
5725	45.52	PK	343	1.4	V	-1.96	43.56	122.2	-78.64
5720	49.34	PK	319	2.1	H	-1.96	47.38	110.8	-63.42
5720	49.69	PK	272	1.2	V	-1.96	47.73	110.8	-63.07
5700	45.11	PK	56	1.5	H	-2.02	43.09	105.2	-62.11
5700	46.88	PK	115	2.1	V	-2.02	44.86	105.2	-60.34
5650	44.47	PK	346	1.6	H	-1.95	42.52	68.2	-25.68
5650	43.39	PK	174	1.2	V	-1.95	41.44	68.2	-26.76
11490	34.26	PK	82	1.1	H	6.63	40.89	74	-33.11

11490	35.29	PK	46	2	V	6.63	41.92	74	-32.08
802.11N20 BAND4, Middle Channel									
11570	33.36	PK	223	1.4	H	6.59	39.95	74	-34.05
11570	34.23	PK	58	1.1	V	6.59	40.82	74	-33.18
802.11N20 BAND4, High Channel									
5850	48.68	PK	279	1.3	H	-1.81	46.87	122.2	-75.33
5850	48.15	PK	224	1.3	V	-1.81	46.34	122.2	-75.86
5855	47.21	PK	172	2.3	H	-1.82	45.39	110.8	-65.41
5855	47.77	PK	295	1.8	V	-1.82	45.95	110.8	-64.85
5875	46.81	PK	24	1.1	H	-1.84	44.97	105.2	-60.23
5875	47.57	PK	319	2.3	V	-1.84	45.73	105.2	-59.47
5925	45.64	PK	251	1.8	H	-1.83	43.81	68.2	-24.39
5925	44.19	PK	17	2.4	V	-1.83	42.36	68.2	-25.84
11650	34.44	PK	37	2.4	H	6.77	41.21	74	-32.79
11650	34.82	PK	52	1.5	V	6.77	41.59	74	-32.41
802.11N40 BAND4, Low Channel									
5725	48.75	PK	12	1.5	H	-1.96	46.79	122.2	-75.41
5725	47.30	PK	123	1.8	V	-1.96	45.34	122.2	-76.86
5720	47.43	PK	51	2.2	H	-1.96	45.47	110.8	-65.33
5720	50.02	PK	138	2.3	V	-1.96	48.06	110.8	-62.74
5700	45.20	PK	226	2.1	H	-2.02	43.18	105.2	-62.02
5700	45.79	PK	207	2.1	V	-2.02	43.77	105.2	-61.43
5650	46.39	PK	308	1.3	H	-1.95	44.44	68.2	-23.76
5650	45.97	PK	129	2.1	V	-1.95	44.02	68.2	-24.18
11510	36.67	PK	203	1.7	H	6.59	43.26	74	-30.74
11510	35.57	PK	355	1.3	V	6.59	42.16	74	-31.84
802.11N40 BAND4, High Channel									
5850	45.61	PK	56	1.8	H	-1.81	43.80	122.2	-78.4
5850	47.52	PK	20	1.1	V	-1.81	45.71	122.2	-76.49
5855	47.36	PK	55	2.5	H	-1.82	45.54	110.8	-65.26
5855	47.84	PK	268	1.6	V	-1.82	46.02	110.8	-64.78
5875	44.71	PK	48	2.3	H	-1.84	42.87	105.2	-62.33
5875	46.19	PK	339	2.2	V	-1.84	44.35	105.2	-60.85
5925	44.17	PK	211	1.9	H	-1.83	42.34	68.2	-25.86
5925	43.66	PK	14	2	V	-1.83	41.83	68.2	-26.37
11590	32.91	PK	125	1.7	H	6.57	39.48	74	-34.52
11590	32.66	PK	55	1.7	V	6.57	39.23	74	-34.77
802.11AC20 BAND4, Low Channel									
5725	45.60	PK	82	1.9	H	-1.96	43.64	122.2	-78.56
5725	47.03	PK	140	1.1	V	-1.96	45.07	122.2	-77.13
5720	48.38	PK	141	1.2	H	-1.96	46.42	110.8	-64.38
5720	47.47	PK	21	1.1	V	-1.96	45.51	110.8	-65.29
5700	47.99	PK	233	1.7	H	-2.02	45.97	105.2	-59.23
5700	48.48	PK	187	2.2	V	-2.02	46.46	105.2	-58.74
5650	45.79	PK	357	1.4	H	-1.95	43.84	68.2	-24.36

5650	45.40	PK	41	1.8	V	-1.95	43.45	68.2	-24.75
11490	32.81	PK	170	1.8	H	6.63	39.44	74	-34.56
11490	35.63	PK	124	2.3	V	6.63	42.26	74	-31.74
802.11 AC20 BAND4, Middle Channel									
11570	35.33	PK	165	2.3	H	6.59	41.92	74	-32.08
11570	34.31	PK	195	1.8	V	6.59	40.90	74	-33.1
802.11 AC20 BAND4, High Channel									
5850	47.63	PK	50	2.2	H	-1.81	45.82	122.2	-76.38
5850	45.88	PK	328	1.6	V	-1.81	44.07	122.2	-78.13
5855	47.01	PK	146	1.6	H	-1.82	45.19	110.8	-65.61
5855	45.80	PK	121	1.9	V	-1.82	43.98	110.8	-66.82
5875	44.64	PK	328	1.8	H	-1.84	42.80	105.2	-62.4
5875	45.06	PK	359	2.2	V	-1.84	43.22	105.2	-61.98
5925	45.64	PK	214	1.3	H	-1.83	43.81	68.2	-24.39
5925	43.57	PK	309	1.6	V	-1.83	41.74	68.2	-26.46
11650	37.39	PK	64	1.2	H	6.77	44.16	74	-29.84
11650	36.47	PK	204	2	V	6.77	43.24	74	-30.76
802.11 AC40 BAND4 5755, Low Channel									
5725	46.73	PK	345	1.9	H	-1.96	44.77	122.2	-77.43
5725	48.14	PK	211	2.2	V	-1.96	46.18	122.2	-76.02
5720	47.87	PK	122	2.5	H	-1.96	45.91	110.8	-64.89
5720	47.95	PK	226	1.5	V	-1.96	45.99	110.8	-64.81
5700	46.15	PK	3	1.3	H	-2.02	44.13	105.2	-61.07
5700	44.45	PK	68	1.4	V	-2.02	42.43	105.2	-62.77
5650	47.99	PK	328	2.4	H	-1.95	46.04	68.2	-22.16
5650	48.76	PK	62	1.5	V	-1.95	46.81	68.2	-21.39
11510	36.39	PK	354	2.2	H	6.59	42.98	74	-31.02
11510	37.13	PK	302	2.3	V	6.59	43.72	74	-30.28
802.11 AC40 BAND4 5795, High Channel									
5850	46.46	PK	240	1.6	H	-1.81	44.65	122.2	-77.55
5850	47.14	PK	295	1.6	V	-1.81	45.33	122.2	-76.87
5855	48.23	PK	115	2	H	-1.82	46.41	110.8	-64.39
5855	47.55	PK	307	2.1	V	-1.82	45.73	110.8	-65.07
5875	45.60	PK	329	2.4	H	-1.84	43.76	105.2	-61.44
5875	46.29	PK	119	2.1	V	-1.84	44.45	105.2	-60.75
5925	43.28	PK	7	2.2	H	-1.83	41.45	68.2	-26.75
5925	44.15	PK	293	2	V	-1.83	42.32	68.2	-25.88
11590	33.65	PK	288	2.4	H	6.57	40.22	74	-33.78
11590	32.84	PK	105	2.1	V	6.57	39.41	74	-34.59
802.11AC80 BAND4 5775									
5725	51.04	PK	162	2.1	H	-1.96	49.08	122.2	-73.12
5725	50.08	PK	6	1.1	V	-1.96	48.12	122.2	-74.08
5720	47.63	PK	110	2.5	H	-1.96	45.67	110.8	-65.13
5720	48.67	PK	299	2.5	V	-1.96	46.71	110.8	-64.09
5700	46.83	PK	286	1.8	H	-2.02	44.81	105.2	-60.39

5700	44.43	PK	210	1.9	V	-2.02	42.41	105.2	-62.79
5650	43.60	PK	188	1.4	H	-1.95	41.65	68.2	-26.55
5650	45.34	PK	265	1.4	V	-1.95	43.39	68.2	-24.81
5850	45.60	PK	76	1.2	H	-1.81	43.79	122.2	-78.41
5850	46.82	PK	278	1.3	V	-1.81	45.01	122.2	-77.19
5855	46.86	PK	197	2.5	H	-1.82	45.04	110.8	-65.76
5855	48.50	PK	107	1.3	V	-1.82	46.68	110.8	-64.12
5875	43.91	PK	188	2	V	-1.84	42.07	105.2	-63.13
5875	45.03	PK	341	1.8	H	-1.84	43.19	105.2	-62.01
5925	43.15	PK	14	2	V	-1.83	41.32	68.2	-26.88
5925	43.84	PK	155	1.2	H	-1.83	42.01	68.2	-26.19
11550	36.16	PK	212	1.8	H	6.61	42.77	74	-31.23
11550	36.61	PK	182	1.9	V	6.61	43.22	74	-30.78

Bluetooth & 2.4G Wi-Fi (802.11b mode, 2437MHz) & 5G Wi-Fi (802.11ac20 mode, 5180MHz) Simultaneously Transmission:

Frequency (MHz)	Receiver		Turntable Degree	Rx Antenna		Corrected Factor (dB/m)	Corrected Amplitude (dB μ V/m)	Limit (dB μ V/m)	Margin (dB)
	Reading (dB μ V)	PK/QP/Ave.		Height (m)	Polar (H/V)				
146.63	53.05	QP	193	1.6	H	-21.71	31.34	43.5	-12.16
325.45	48.66	QP	321	2.2	V	-16.77	31.89	46	-14.11
2571.06	51.92	PK	273	1.3	H	-6.9	45.02	74	-28.98
2716.74	50.36	PK	259	2.4	V	-6.6	43.76	74	-30.24

Note:

Corrected Factor = Antenna factor (RX) + Cable Loss – Amplifier Factor

Corrected Amplitude = Corrected Factor + Reading

Margin = Corrected Amplitude – Limit

The other spurious emission which is in the noise floor level was not recorded.

The test result of peak was 20dB below to the limit of peak, which can be compliant to the average limit, so just peak value was recorded.

1-18 GHz:

Pre-scan plots:

802.11ac40 5230MHz
Horizontal:

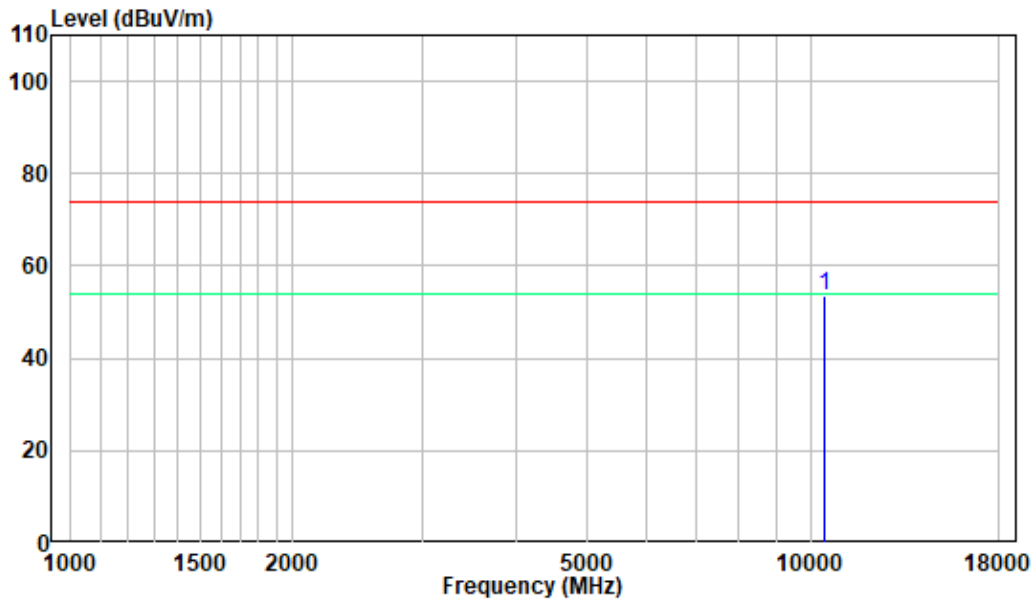

Vertical:

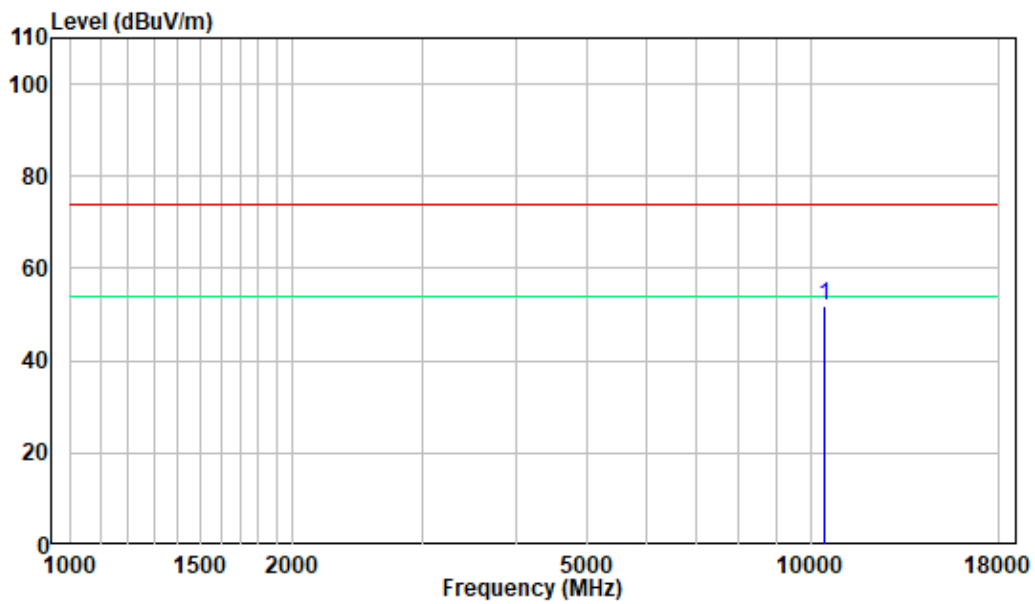

18-40 GHz:

Pre-scan plots:

802.11ac40 5230MHz
Horizontal:

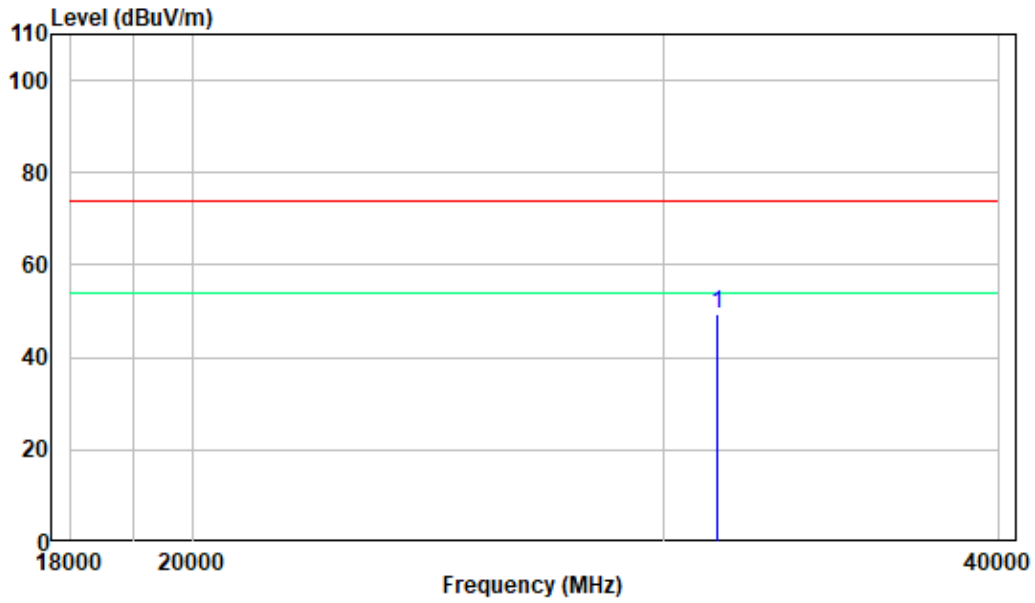

Vertical:

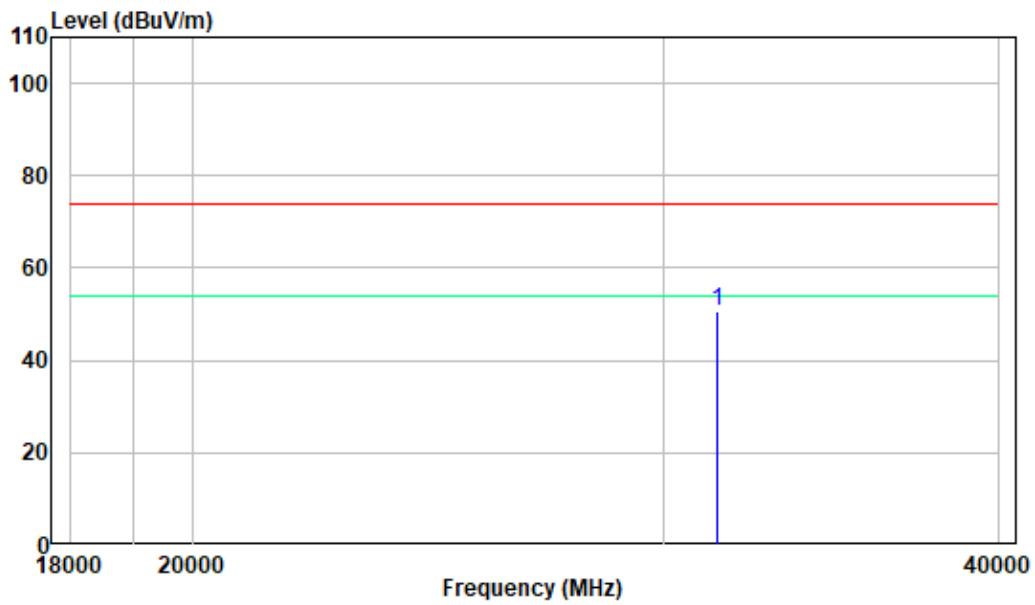

FCC §15.407(a)(e) – BANDWIDTH

Applicable Standard

The maximum power spectral density is measured as a conducted emission by direct connection of a calibrated test instrument to the equipment under test. If the device cannot be connected directly, alternative techniques acceptable to the Commission may be used. Measurements in the 5.725-5.85 GHz band are made over a reference bandwidth of 500 kHz or the 26 dB emission bandwidth of the device, whichever is less. Measurements in the 5.15-5.25 GHz, 5.25-5.35 GHz, and the 5.47-5.725 GHz bands are made over a bandwidth of 1 MHz or the 26 dB emission bandwidth of the device, whichever is less. A narrower resolution bandwidth can be used, provided that the measured power is integrated over the full reference bandwidth.

Within the 5.725-5.85 GHz band, the minimum 6 dB bandwidth of U-NII devices shall be at least 500 kHz.

Test Procedure

1. Emission Bandwidth (EBW)

- a) Set RBW = approximately 1% of the emission bandwidth.
- b) Set the VBW > RBW.
- c) Detector = Peak.
- d) Trace mode = max hold.
- e) Measure the maximum width of the emission that is 26 dB down from the maximum of the emission. Compare this with the RBW setting of the analyzer. Readjust RBW and repeat measurement as needed until the RBW/EBW ratio is approximately 1%.

2. Minimum Emission Bandwidth for the band 5.725-5.85 GHz

Section 15.407(e) specifies the minimum 6 dB emission bandwidth of at least 500 KHz for the band 5.715-5.85 GHz. The following procedure shall be used for measuring this bandwidth:

- a) Set RBW = 100 kHz.
- b) Set the video bandwidth (VBW) $\geq 3 \times$ RBW.
- c) Detector = Peak.
- d) Trace mode = max hold.
- e) Sweep = auto couple.
- f) Allow the trace to stabilize.
- g) Measure the maximum width of the emission that is constrained by the frequencies associated with the two outermost amplitude points (upper and lower frequencies) that are attenuated by 6 dB relative to the maximum level measured in the fundamental emission.

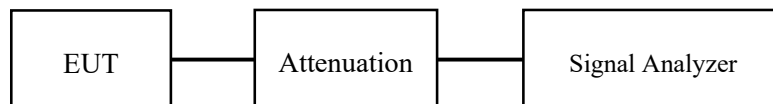

Test Data

Environmental Conditions

Temperature:	25 °C
Relative Humidity:	52 %
ATM Pressure:	101.0 kPa

The testing was performed by Fan Yang on 2021-11-23.

EUT operation mode: Transmitting

Test Result: Pass; please refer to the Appendix.

FCC §15.407(a) (1) (3) – CONDUCTED TRANSMITTER OUTPUT POWER

Applicable Standard

For client devices in the 5.15-5.25 GHz band, the maximum conducted output power over the frequency band of operation shall not exceed 250 mW provided the maximum antenna gain does not exceed 6 dBi. In addition, the maximum power spectral density shall not exceed 11 dBm in any 1 megahertz band. If transmitting antennas of directional gain greater than 6 dBi are used, both the maximum conducted output power and the maximum power spectral density shall be reduced by the amount in dB that the directional gain of the antenna exceeds 6 dBi.

For the band 5.725-5.85 GHz, the maximum conducted output power over the frequency band of operation shall not exceed 1 W. In addition, the maximum power spectral density shall not exceed 30 dBm in any 500-kHz band. If transmitting antennas of directional gain greater than 6 dBi are used, both the maximum conducted output power and the maximum power spectral density shall be reduced by the amount in dB that the directional gain of the antenna exceeds 6 dBi. However, fixed point-to-point U-NII devices operating in this band may employ transmitting antennas with directional gain greater than 6 dBi without any corresponding reduction in transmitter conducted power. Fixed, point-to-point operations exclude the use of point-to-multipoint systems, omnidirectional applications, and multiple collocated transmitters transmitting the same information. The operator of the U-NII device, or if the equipment is professionally installed, the installer, is responsible for ensuring that systems employing high gain directional antennas are used exclusively for fixed, point-to-point operations.

Test Procedure

1. Place the EUT on a bench and set it in transmitting mode.
2. Remove the antenna from the EUT and then connect a low loss RF cable from the antenna port to one test equipment.
3. Add a correction factor to the display.

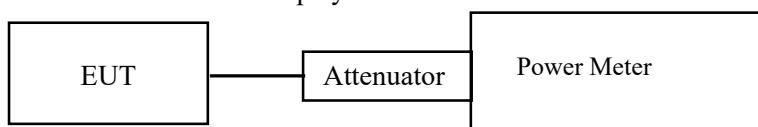

Test Data

Environmental Conditions

Temperature:	25 °C
Relative Humidity:	52 %
ATM Pressure:	101.0 kPa

The testing was performed by Fan Yang on 2021-11-23.

EUT operation mode: Transmitting

Test Result: Pass

Please refer to the Appendix.

FCC §15.407(a) (1) (3) - POWER SPECTRAL DENSITY**Applicable Standard**

For client devices in the 5.15-5.25 GHz band, the maximum conducted output power over the frequency band of operation shall not exceed 250 mW provided the maximum antenna gain does not exceed 6 dBi. In addition, the maximum power spectral density shall not exceed 11 dBm in any 1 megahertz band. If transmitting antennas of directional gain greater than 6 dBi are used, both the maximum conducted output power and the maximum power spectral density shall be reduced by the amount in dB that the directional gain of the antenna exceeds 6 dBi.

For the band 5.725-5.85 GHz, the maximum conducted output power over the frequency band of operation shall not exceed 1 W. In addition, the maximum power spectral density shall not exceed 30 dBm in any 500-kHz band. If transmitting antennas of directional gain greater than 6 dBi are used, both the maximum conducted output power and the maximum power spectral density shall be reduced by the amount in dB that the directional gain of the antenna exceeds 6 dBi. However, fixed point-to-point U-NII devices operating in this band may employ transmitting antennas with directional gain greater than 6 dBi without any corresponding reduction in transmitter conducted power. Fixed, point-to-point operations exclude the use of point-to-multipoint systems, omnidirectional applications, and multiple collocated transmitters transmitting the same information. The operator of the U-NII device, or if the equipment is professionally installed, the installer, is responsible for ensuring that systems employing high gain directional antennas are used exclusively for fixed, point-to-point operations.

Test Procedure

For devices operating in the bands 5.15-5.25 GHz, 5.25-5.35 GHz, and 5.47-5.725 GHz, the above procedures make use of 1 MHz RBW to satisfy directly the 1 MHz reference bandwidth specified in § 15.407(a)(5). For devices operating in the band 5.725-5.85 GHz, the rules specify a measurement bandwidth of 500 kHz. Many spectrum analyzers do not have 500 kHz RBW, thus a narrower RBW may need to be used. The rules permit the use of a RBWs less than 1 MHz, or 500 kHz, “provided that the measured power is integrated over the full reference bandwidth” to show the total power over the specified measurement bandwidth (i.e., 1 MHz, or 500 kHz). If measurements are performed using a reduced resolution bandwidth (< 1 MHz, or < 500 kHz) and integrated over 1 MHz, or 500 kHz bandwidth, the following adjustments to the procedures apply:

- a) Set $RBW \geq 1/T$, where T is defined in section II.B.1.a).
- b) Set $VBW \geq 3 RBW$.
- c) If measurement bandwidth of Maximum PSD is specified in 500 kHz, add $10 \log(500 \text{ kHz}/RBW)$ to the measured result, whereas $RBW (< 500 \text{ kHz})$ is the reduced resolution bandwidth of the spectrum analyzer set during measurement.
- d) If measurement bandwidth of Maximum PSD is specified in 1 MHz, add $10 \log(1\text{MHz}/RBW)$ to the measured result, whereas $RBW (< 1 \text{ MHz})$ is the reduced resolution bandwidth of spectrum analyzer set during measurement.
- e) Care must be taken to ensure that the measurements are performed during a period of continuous transmission or are corrected upward for duty cycle.

Test Data**Environmental Conditions**

Temperature:	25 °C
Relative Humidity:	52 %
ATM Pressure:	101.0 kPa

The testing was performed by Fan Yang from 2021-11-23 to 2021-11-25.

EUT operation mode: Transmitting

Test Result: Pass

Please refer to the Appendix.

APPENDIX**Appendix A1: Emission Bandwidth
Test Result**

TestMode	Antenna	Channel	26db EBW [MHz]	FL[MHz]	FH[MHz]	Limit[MHz]	Verdict
11A	Ant0	5180	23.320	5168.360	5191.680	---	PASS
		5200	23.360	5188.320	5211.680	---	PASS
		5240	22.720	5228.640	5251.360	---	PASS
		5745	23.040	5733.600	5756.640	---	PASS
		5785	23.280	5773.200	5796.480	---	PASS
		5825	23.360	5813.160	5836.520	---	PASS
11N20	Ant0	5180	23.120	5168.600	5191.720	---	PASS
		5200	23.320	5188.360	5211.680	---	PASS
		5240	23.400	5228.280	5251.680	---	PASS
		5745	23.440	5733.280	5756.720	---	PASS
		5785	23.440	5773.240	5796.680	---	PASS
		5825	23.120	5813.400	5836.520	---	PASS
11N40	Ant0	5190	45.360	5167.680	5213.040	---	PASS
		5230	46.560	5206.880	5253.440	---	PASS
		5755	45.280	5732.200	5777.480	---	PASS
		5795	45.600	5772.200	5817.800	---	PASS
11AC20	Ant0	5180	23.320	5168.320	5191.640	---	PASS
		5200	24.360	5187.400	5211.760	---	PASS
		5240	23.320	5228.400	5251.720	---	PASS
		5745	23.400	5733.280	5756.680	---	PASS
		5785	23.440	5773.200	5796.640	---	PASS
		5825	23.320	5813.280	5836.600	---	PASS
11AC40	Ant0	5190	45.600	5167.040	5212.640	---	PASS
		5230	45.120	5207.520	5252.640	---	PASS
		5755	44.880	5732.600	5777.480	---	PASS
		5795	45.520	5772.280	5817.800	---	PASS
11AC80	Ant0	5210	85.280	5167.280	5252.560	---	PASS
		5775	85.600	5732.280	5817.880	---	PASS

TestMode	Antenna	Channel	26db EBW [MHz]	FL[MHz]	FH[MHz]	Limit[MHz]	Verdict
11A	Ant1	5180	23.120	5168.600	5191.720	---	PASS
		5200	23.440	5188.280	5211.720	---	PASS
		5240	23.320	5228.360	5251.680	---	PASS
		5745	23.000	5733.640	5756.640	---	PASS
		5785	23.080	5773.320	5796.400	---	PASS
		5825	23.320	5813.280	5836.600	---	PASS
11N20	Ant1	5180	23.440	5168.240	5191.680	---	PASS
		5200	23.440	5188.280	5211.720	---	PASS
		5240	23.440	5228.240	5251.680	---	PASS
		5745	23.280	5733.360	5756.640	---	PASS
		5785	23.320	5773.320	5796.640	---	PASS
		5825	23.600	5813.120	5836.720	---	PASS
11N40	Ant1	5190	44.720	5167.680	5212.400	---	PASS
		5230	45.040	5207.520	5252.560	---	PASS
		5755	45.360	5732.200	5777.560	---	PASS
		5795	45.920	5772.120	5818.040	---	PASS
11AC20	Ant1	5180	23.440	5168.320	5191.760	---	PASS
		5200	23.440	5188.280	5211.720	---	PASS
		5240	23.440	5228.280	5251.720	---	PASS
		5745	23.120	5733.560	5756.680	---	PASS
		5785	23.160	5773.520	5796.680	---	PASS
		5825	23.400	5813.320	5836.720	---	PASS
11AC40	Ant1	5190	45.120	5167.760	5212.880	---	PASS
		5230	45.360	5207.520	5252.880	---	PASS
		5755	45.280	5732.200	5777.480	---	PASS
		5795	45.040	5772.440	5817.480	---	PASS
11AC80	Ant1	5210	86.400	5167.280	5253.680	---	PASS
		5775	84.640	5732.920	5817.560	---	PASS

Test Graphs

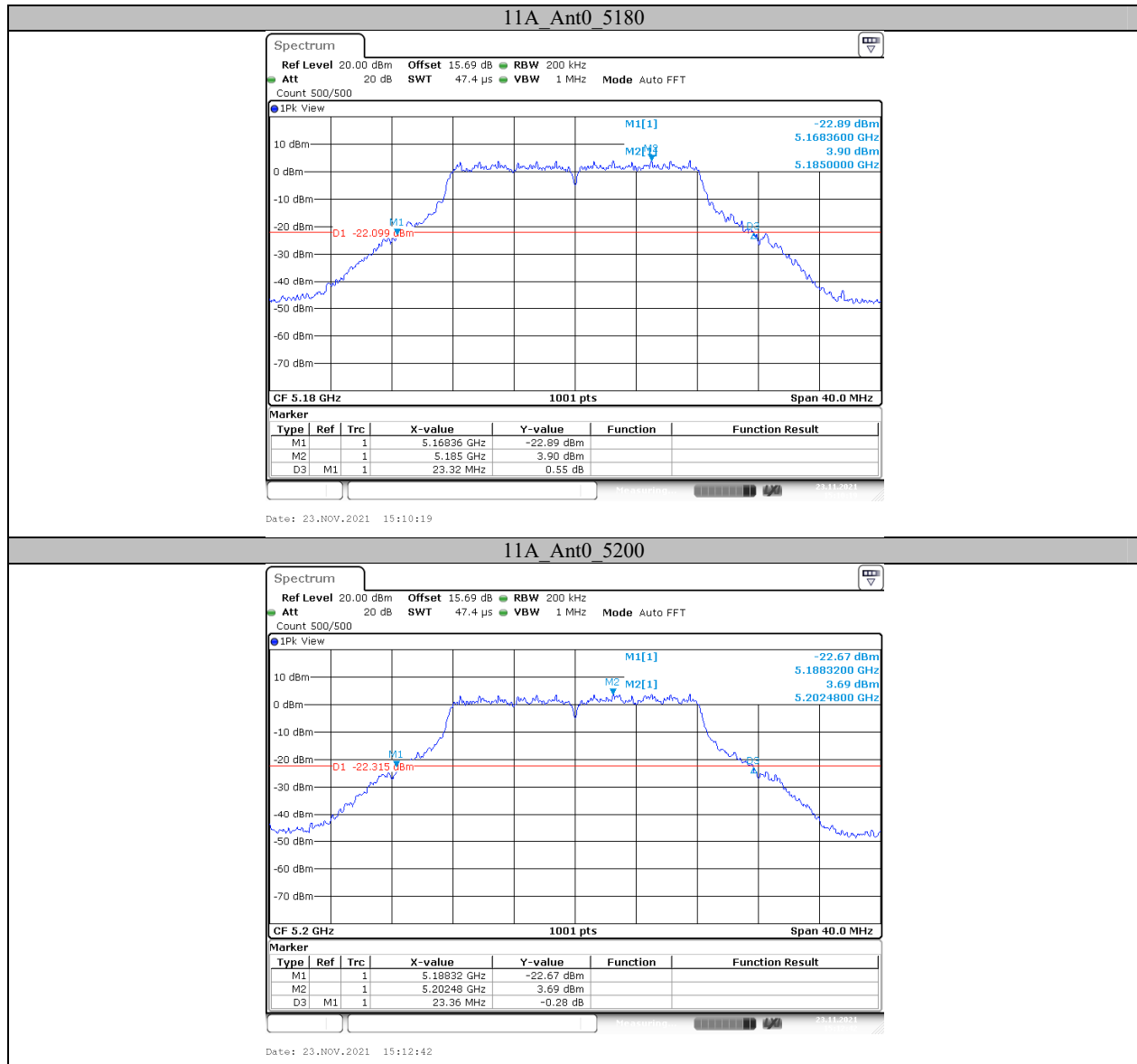

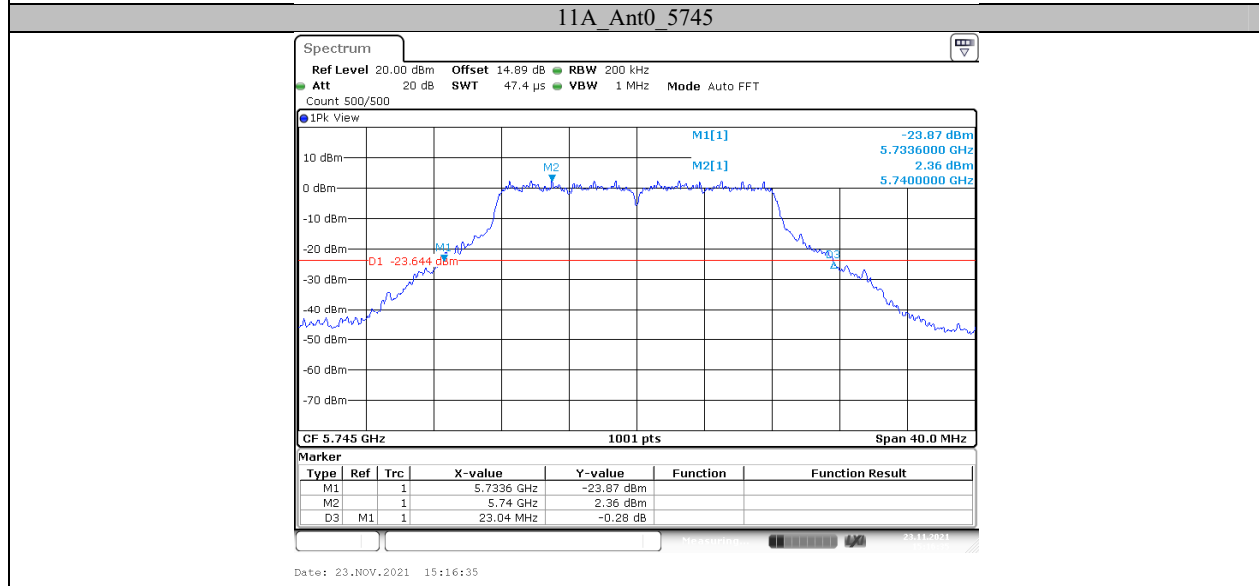
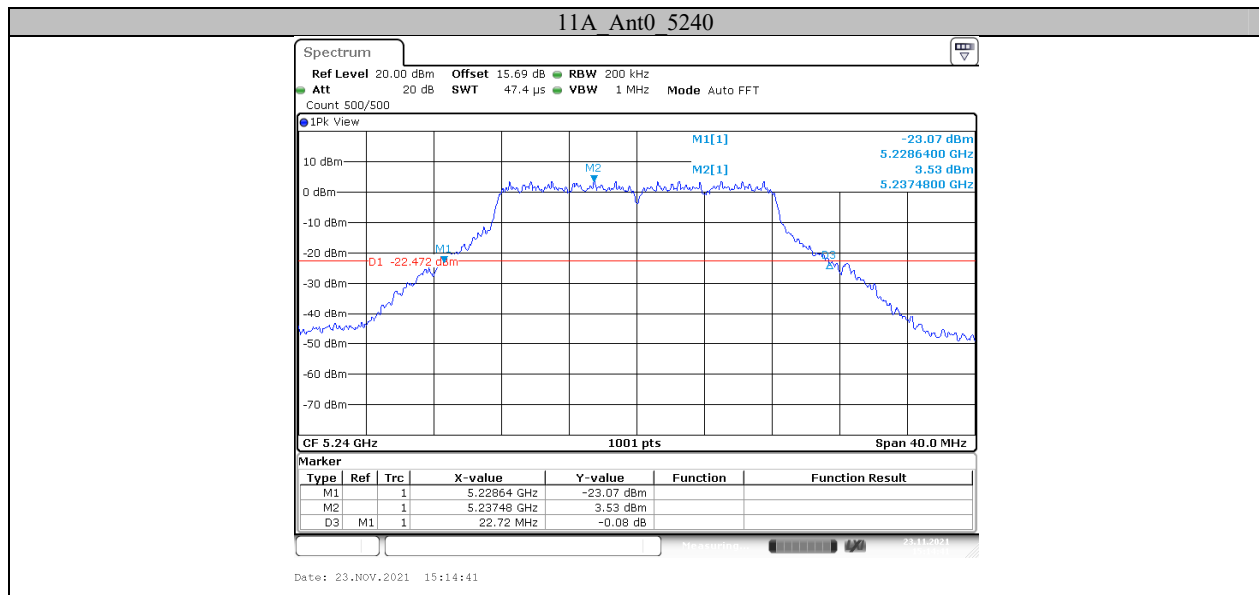

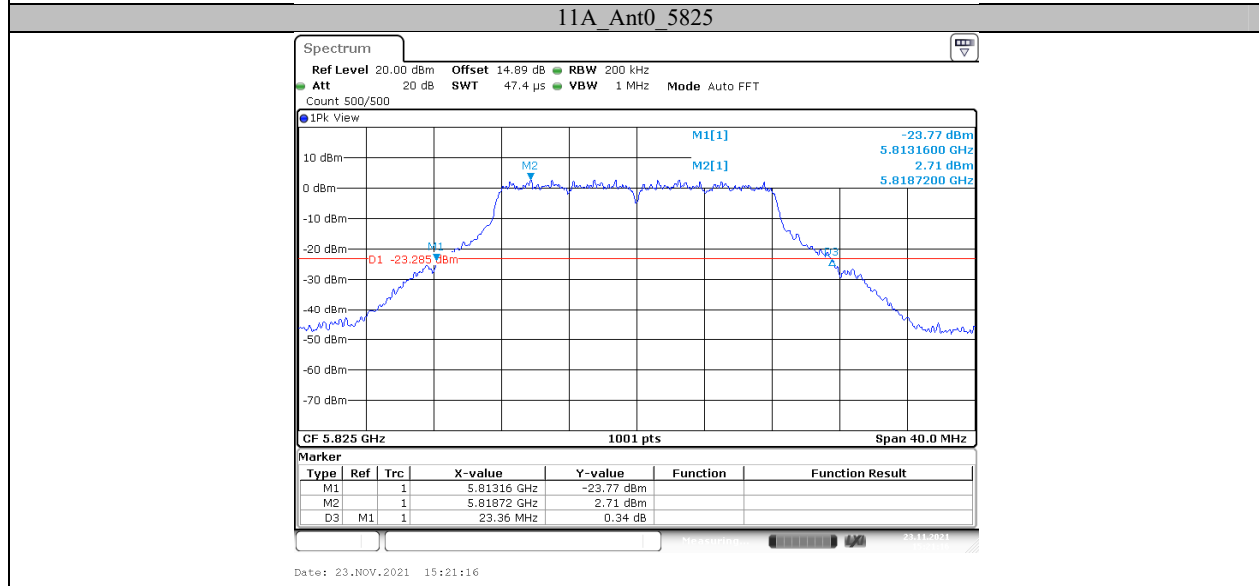
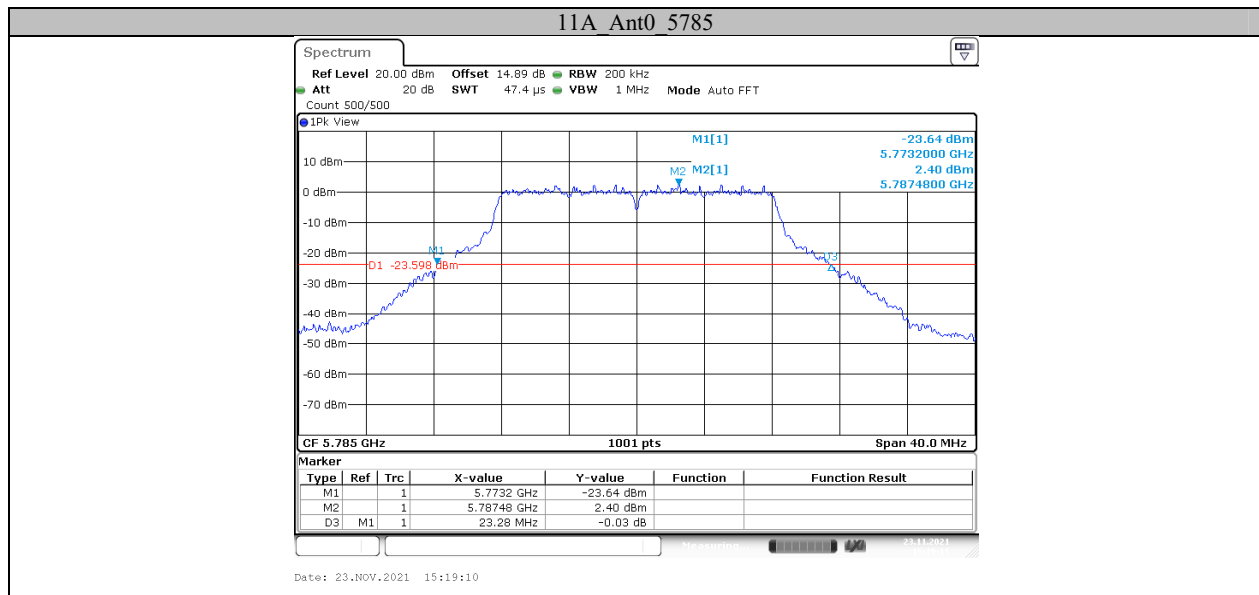

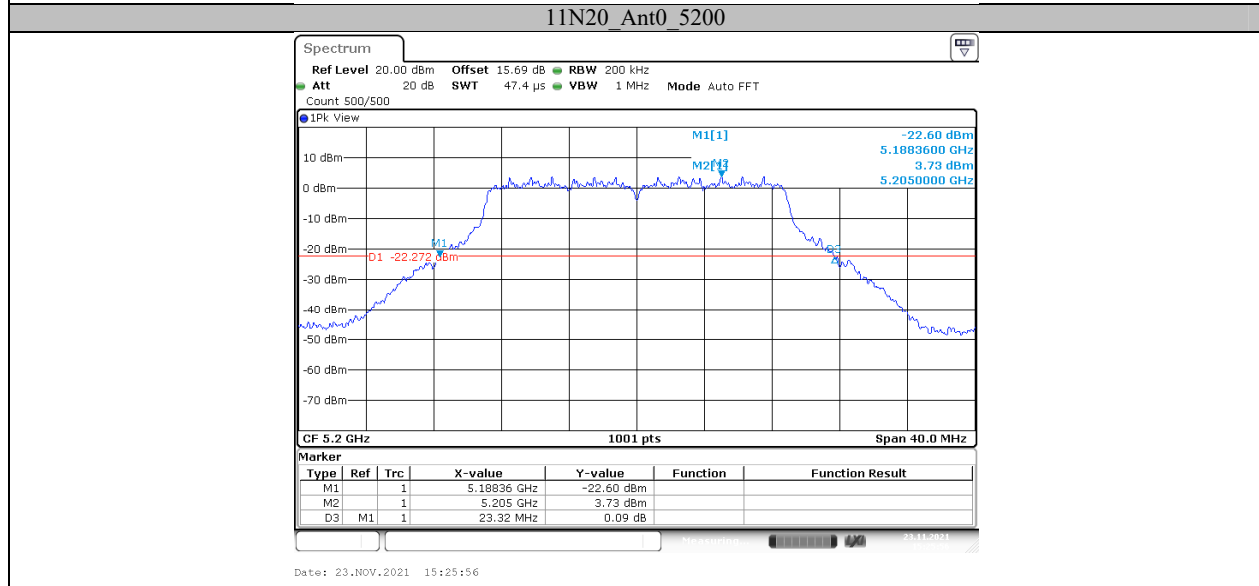
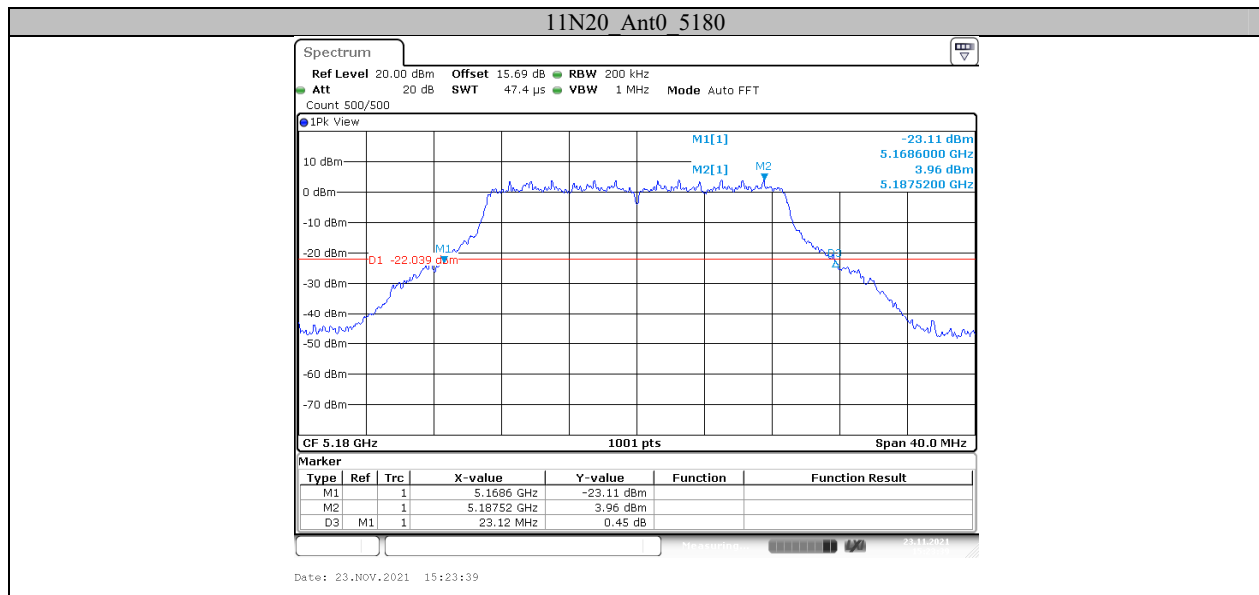

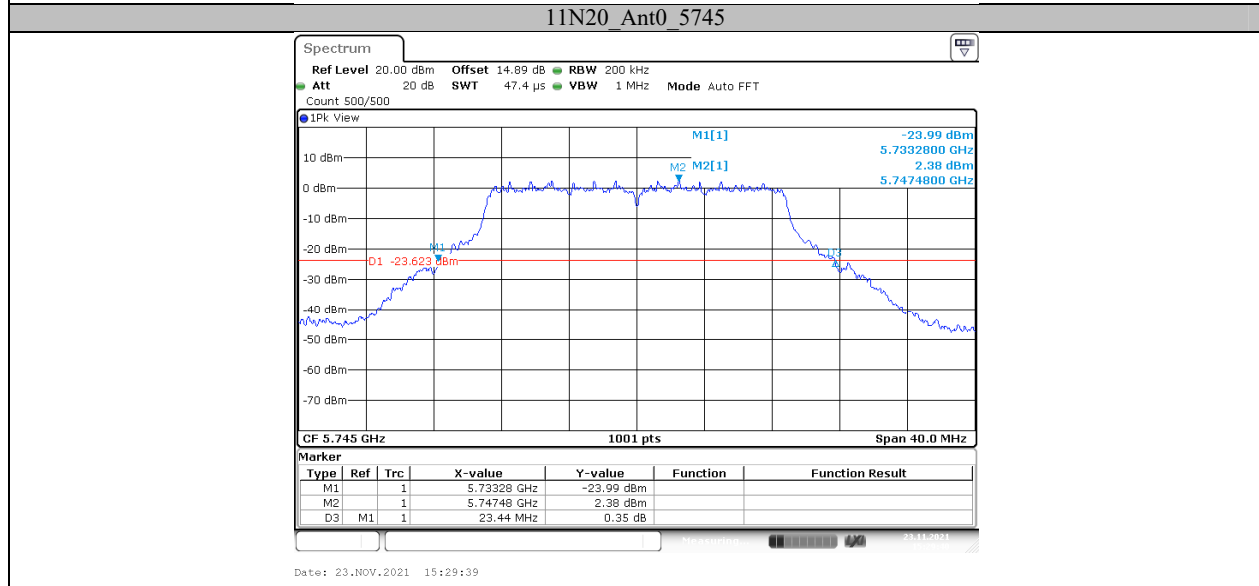
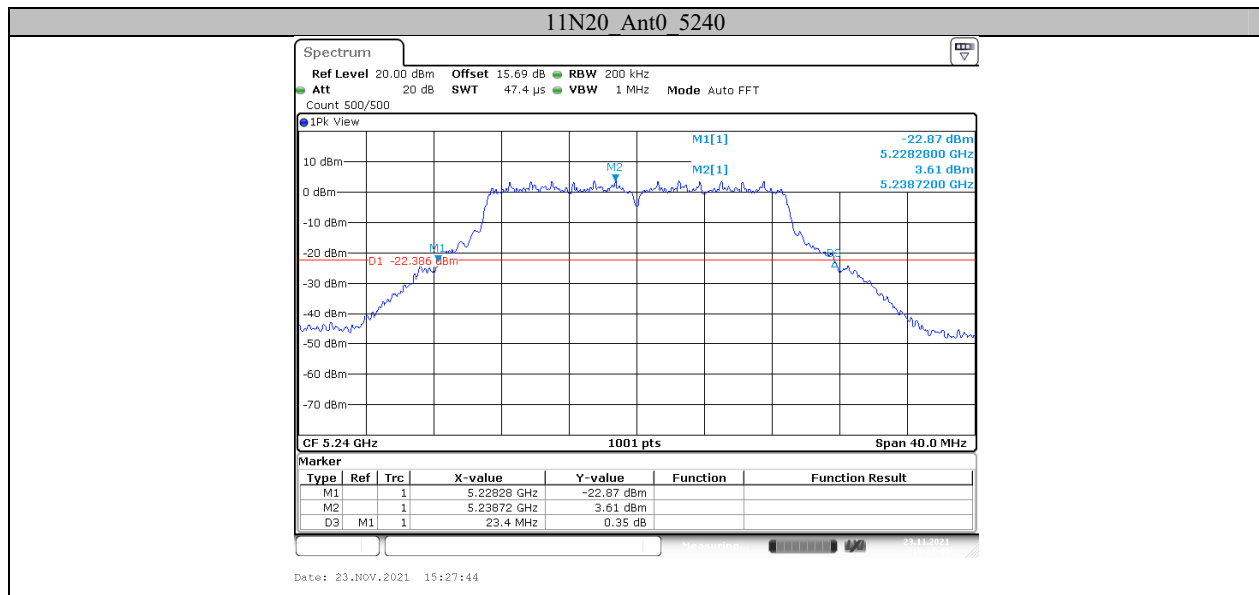

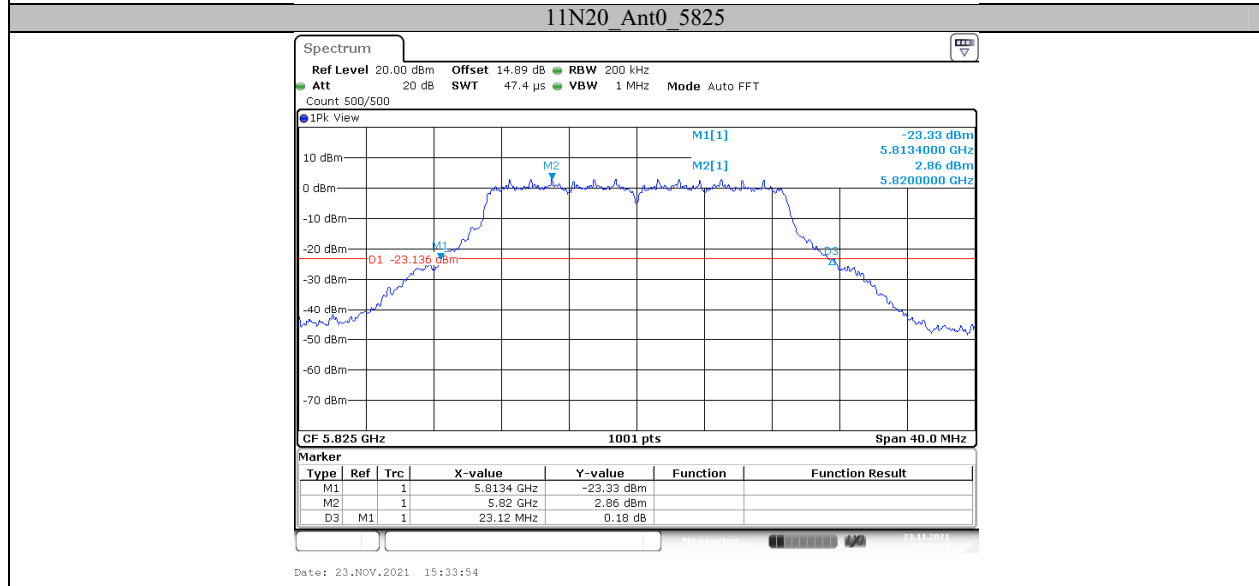
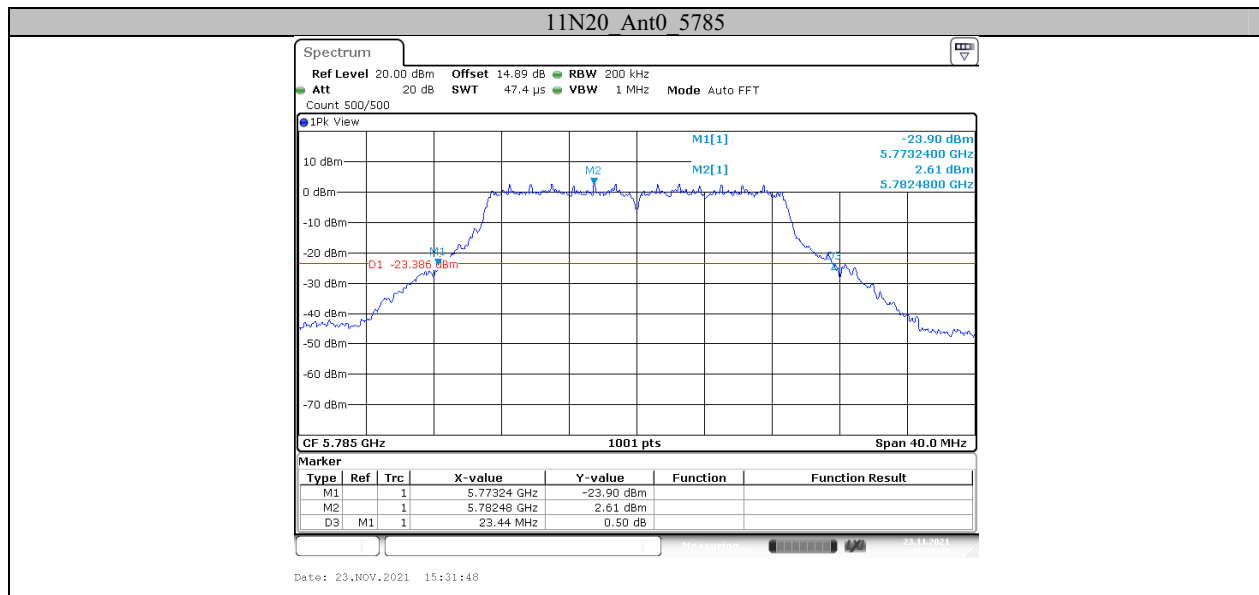

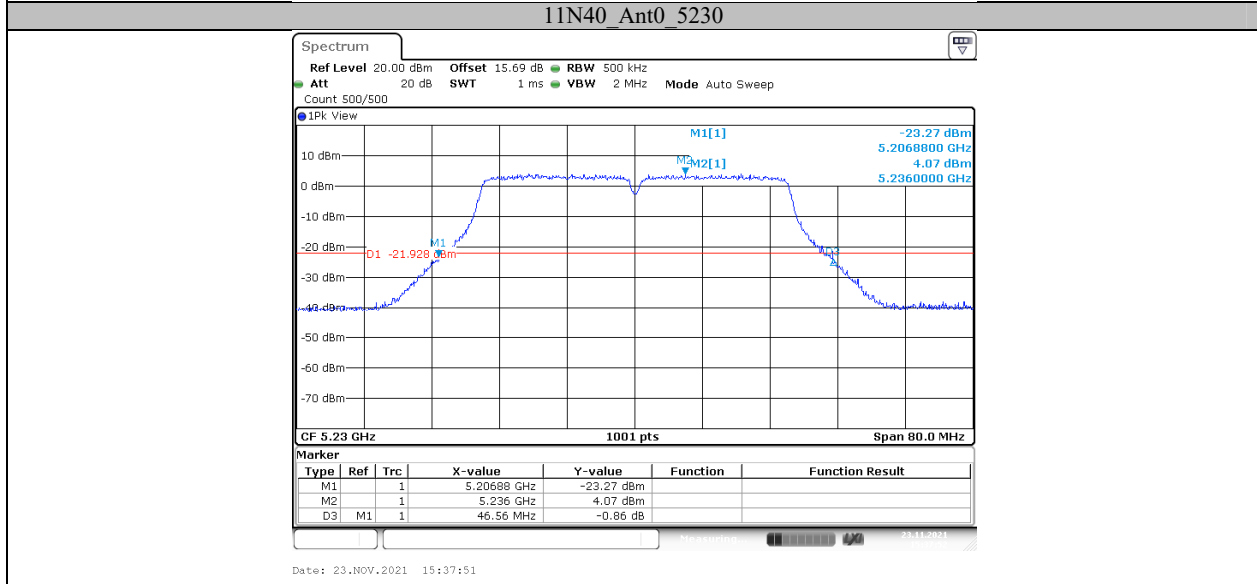
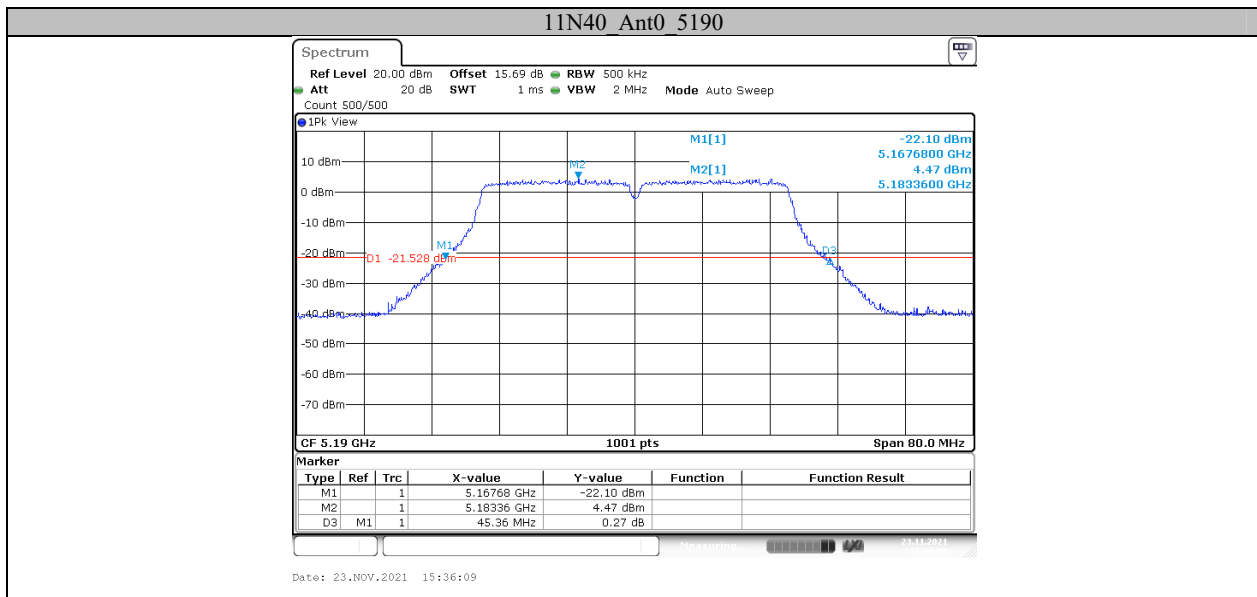

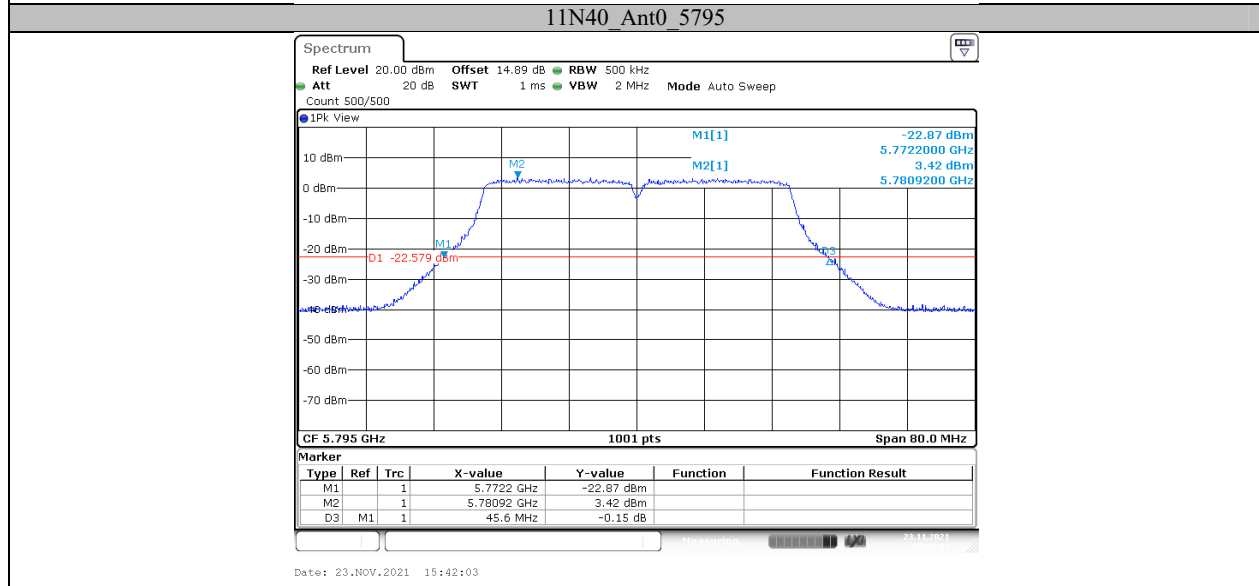
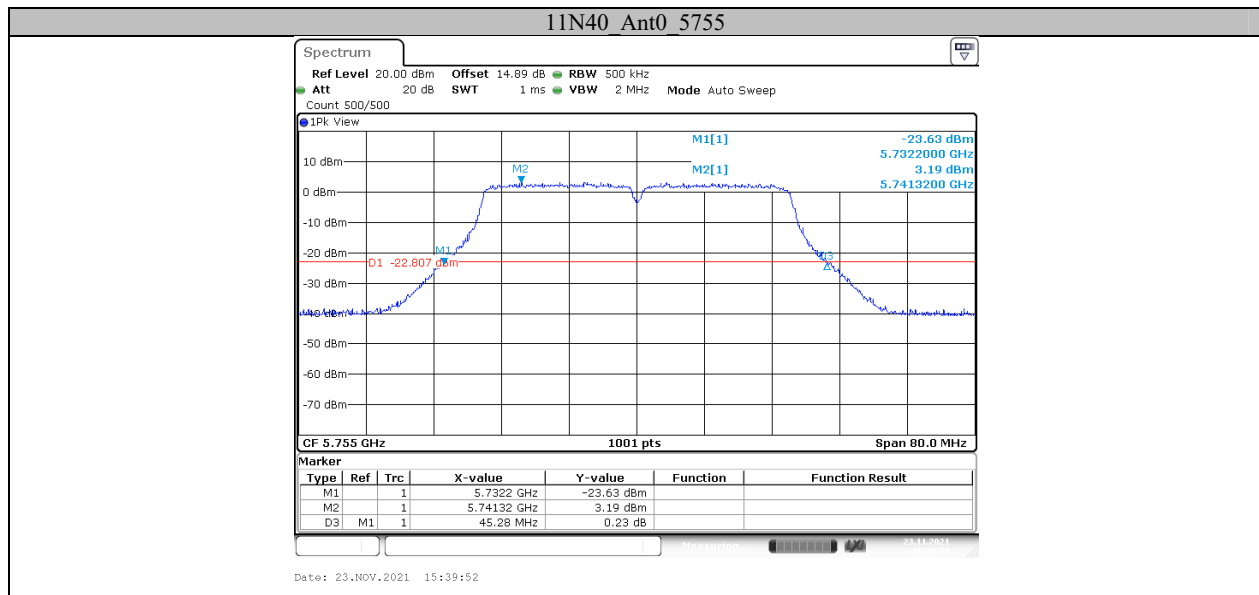

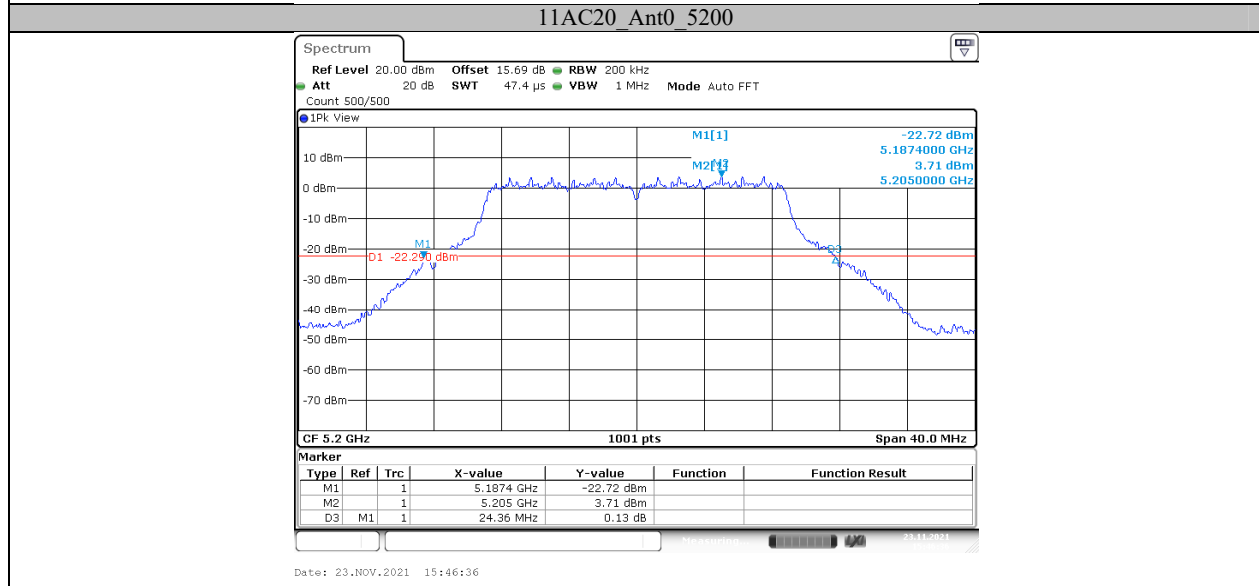
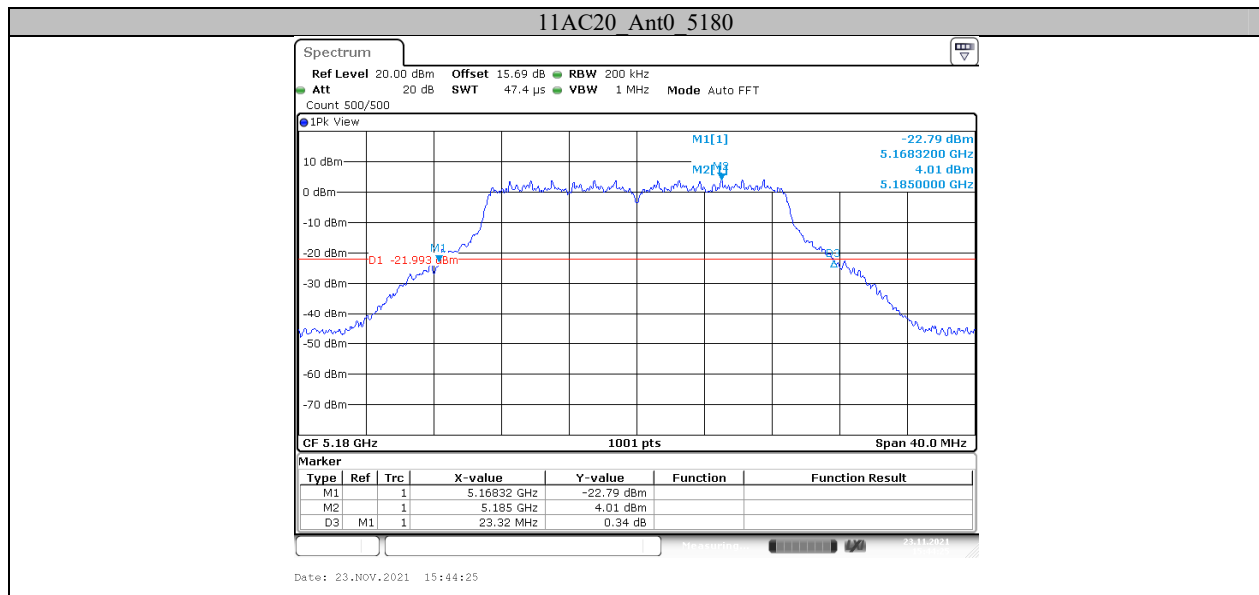

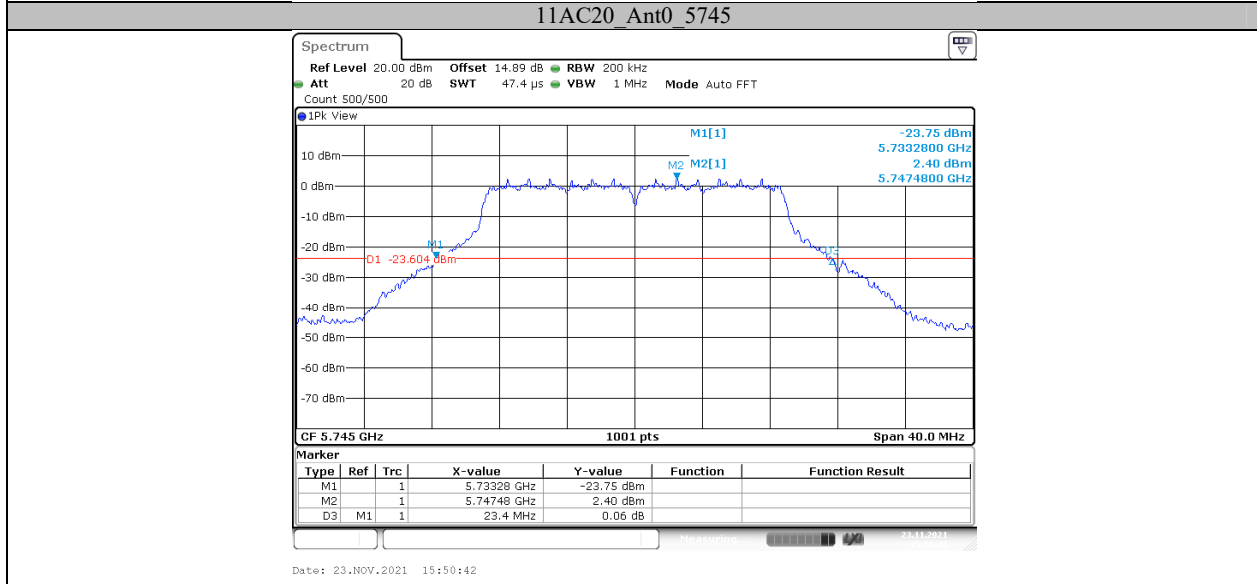
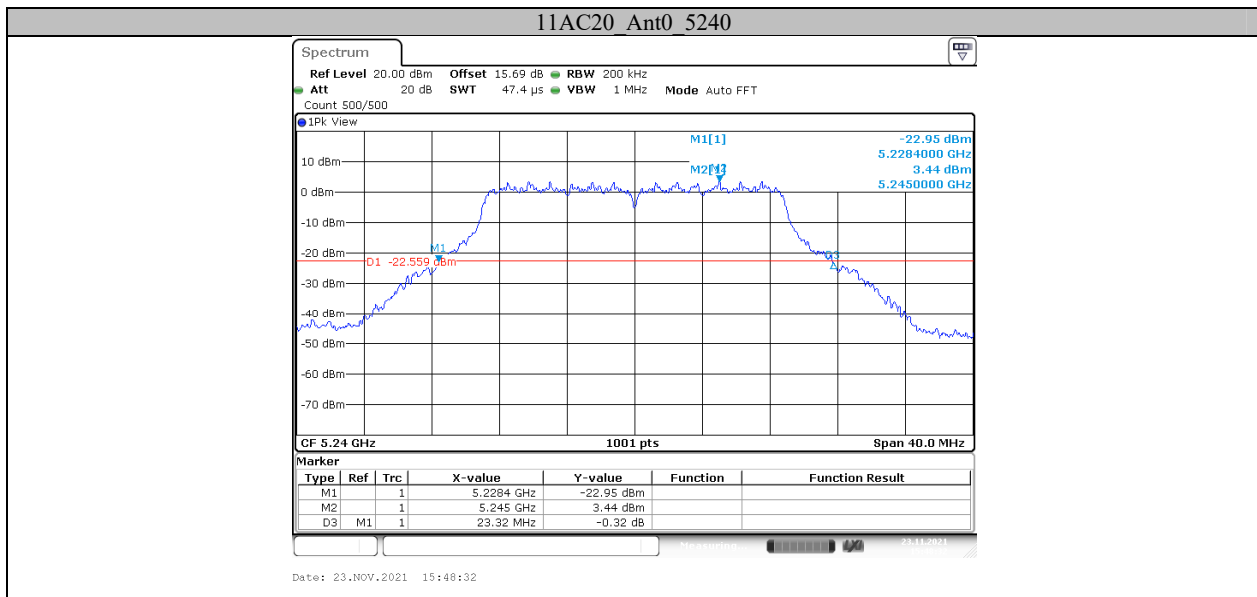

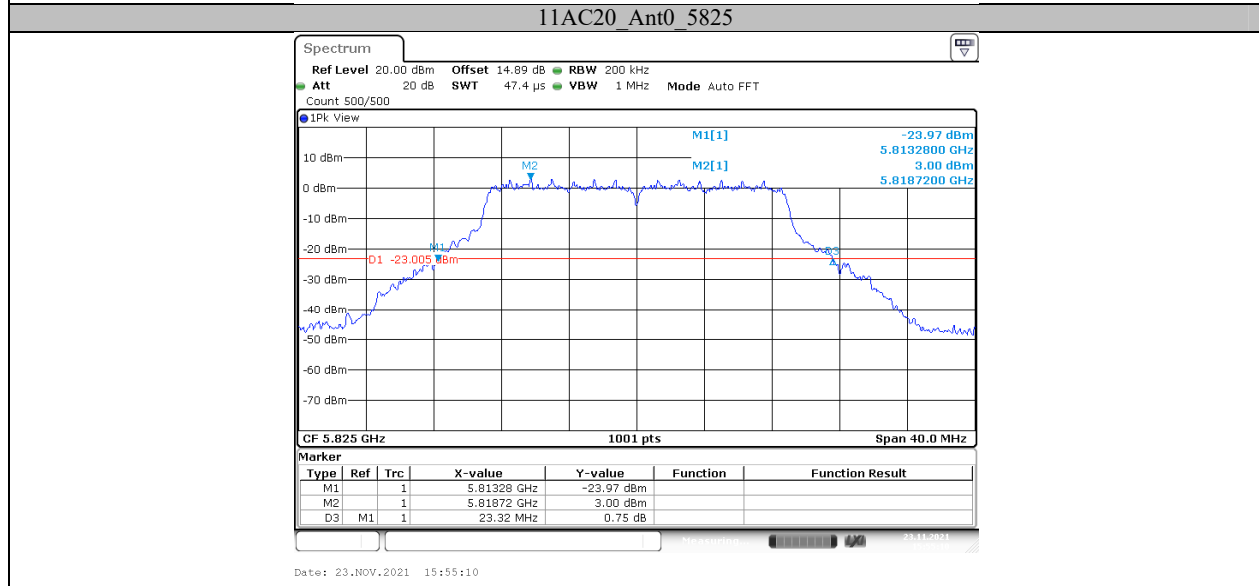
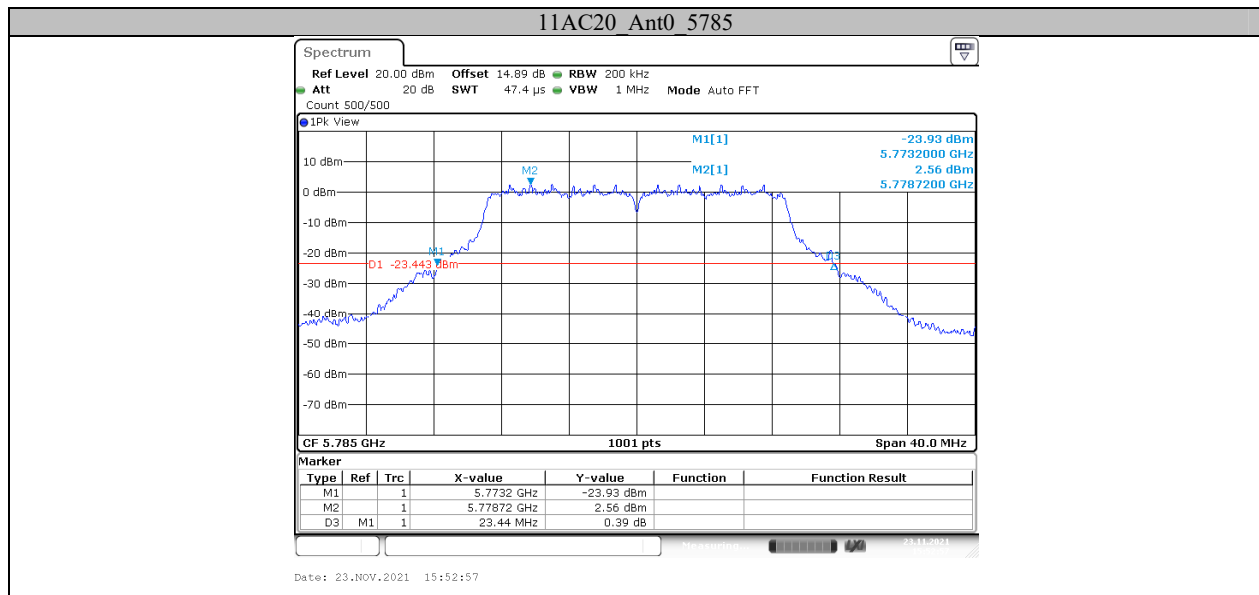

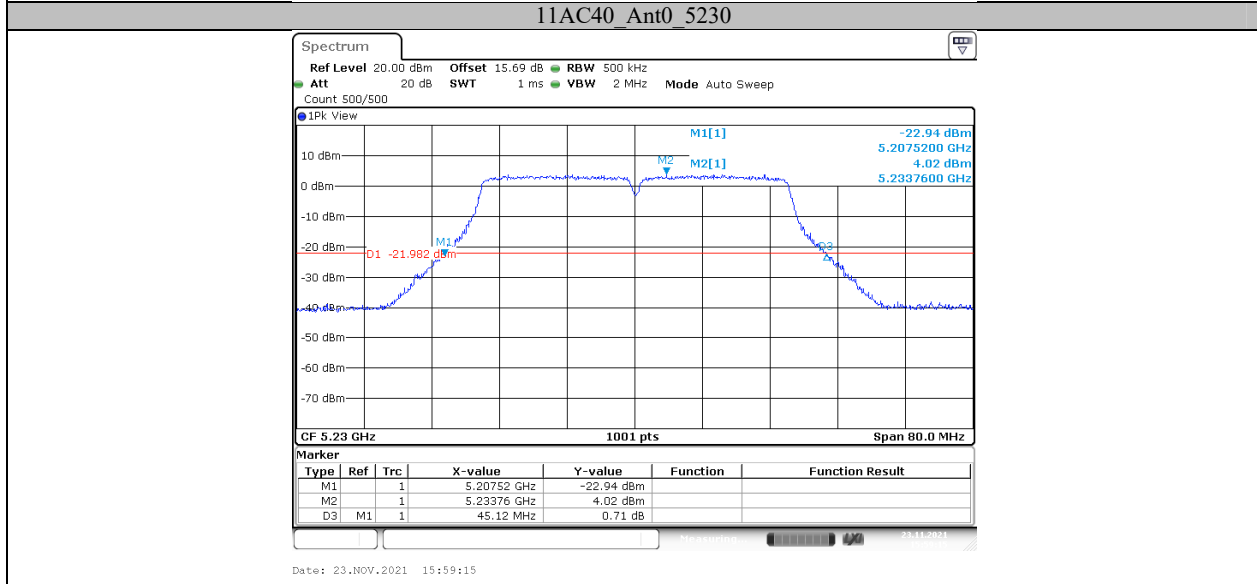
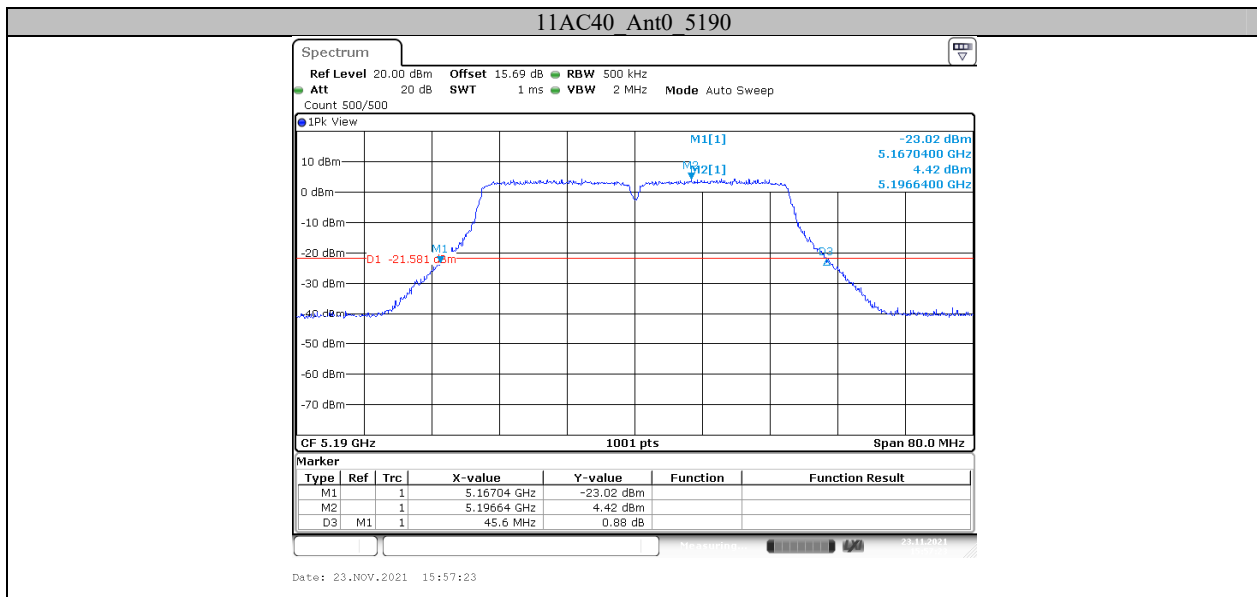

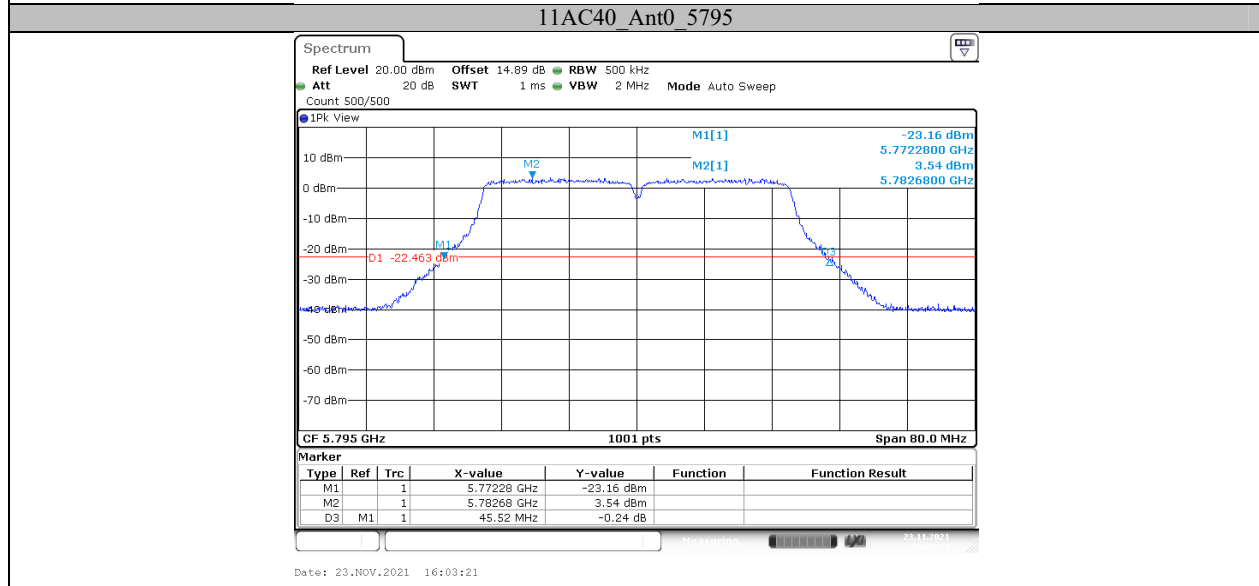
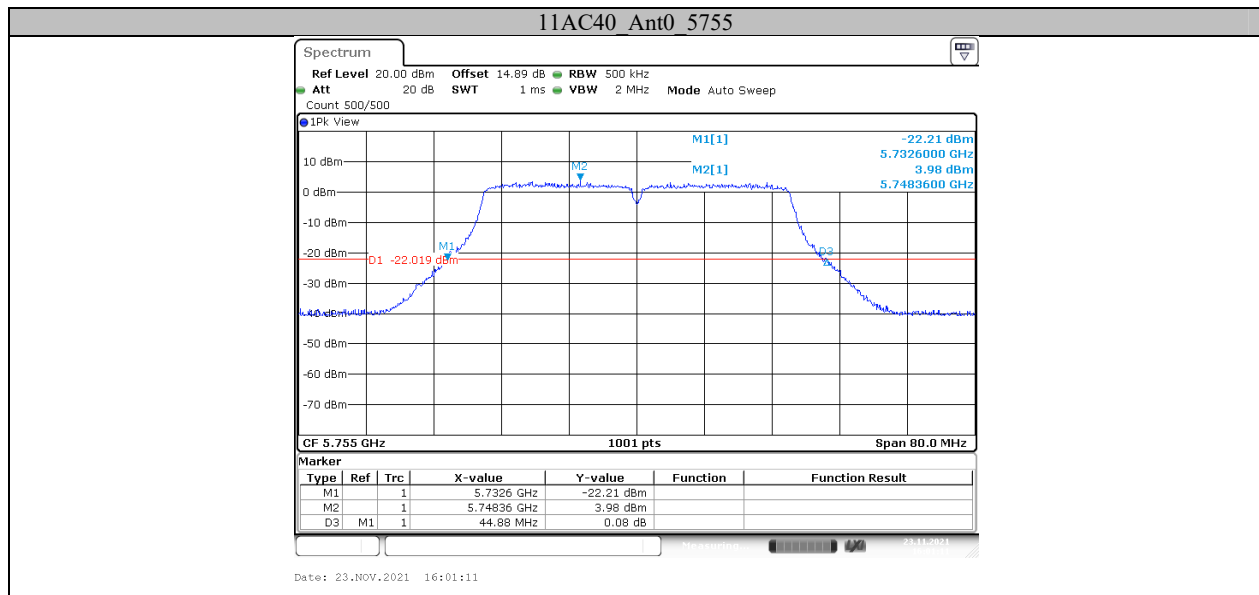

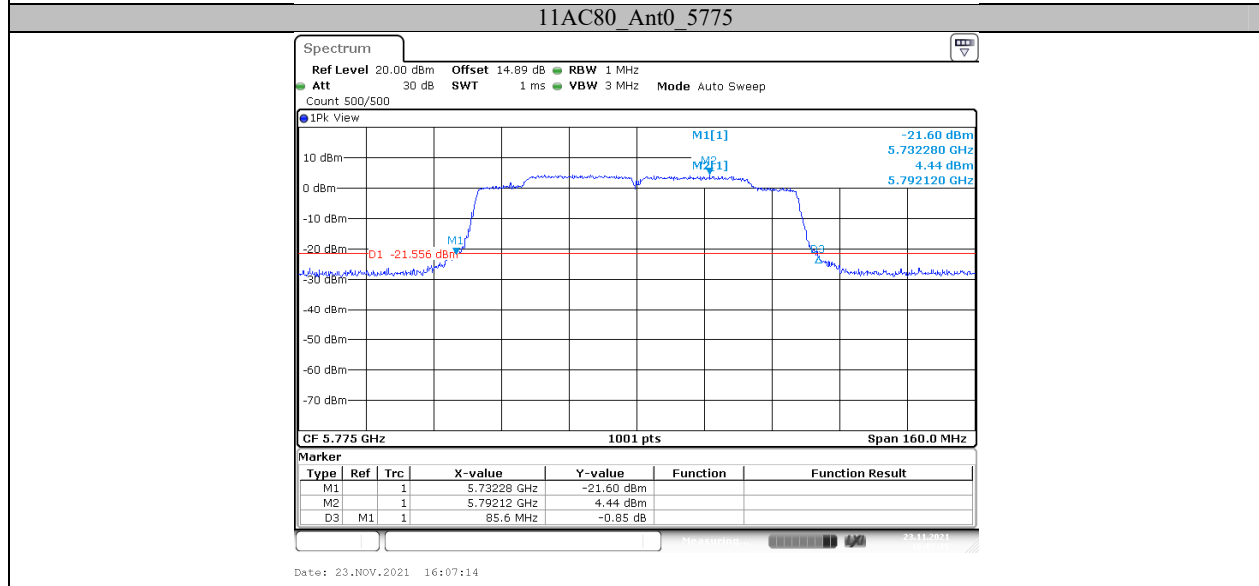
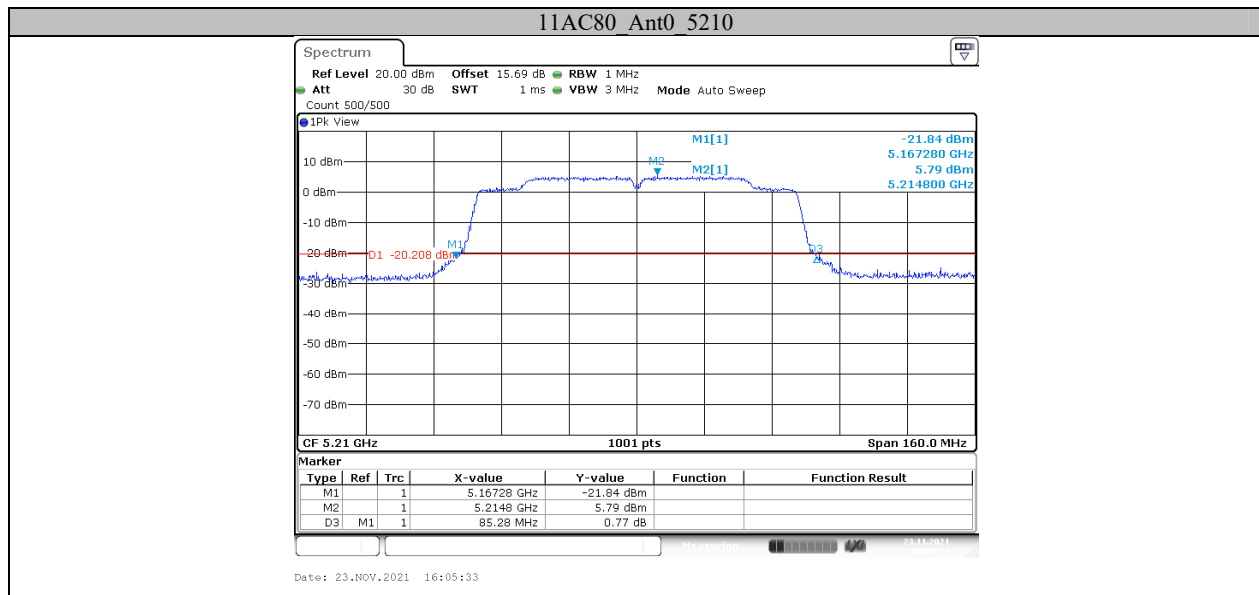

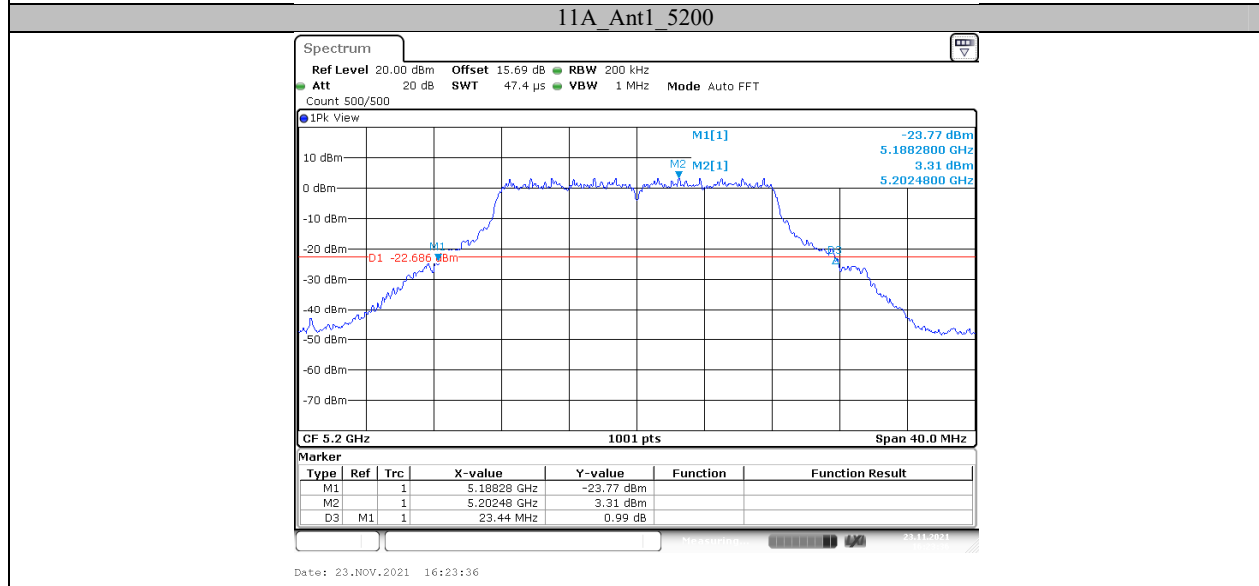
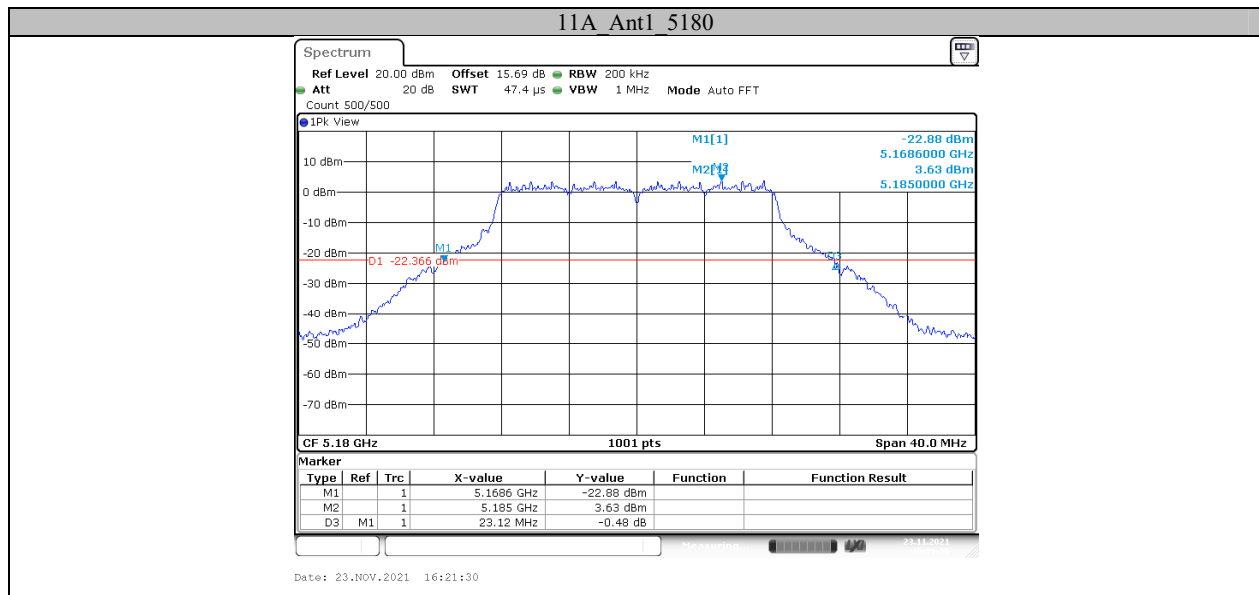

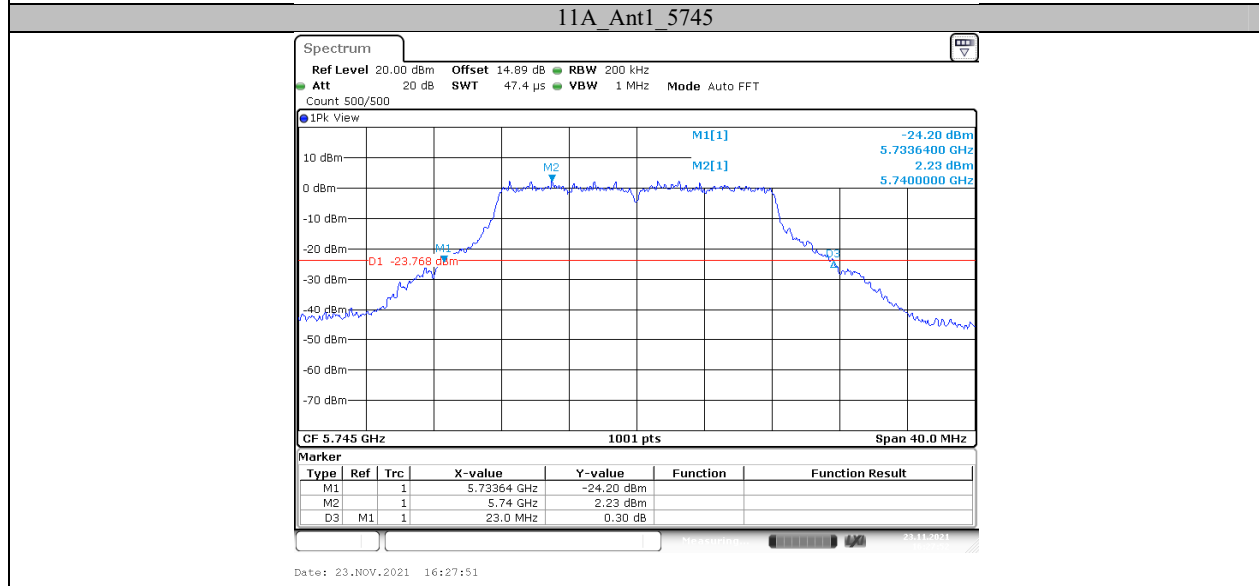
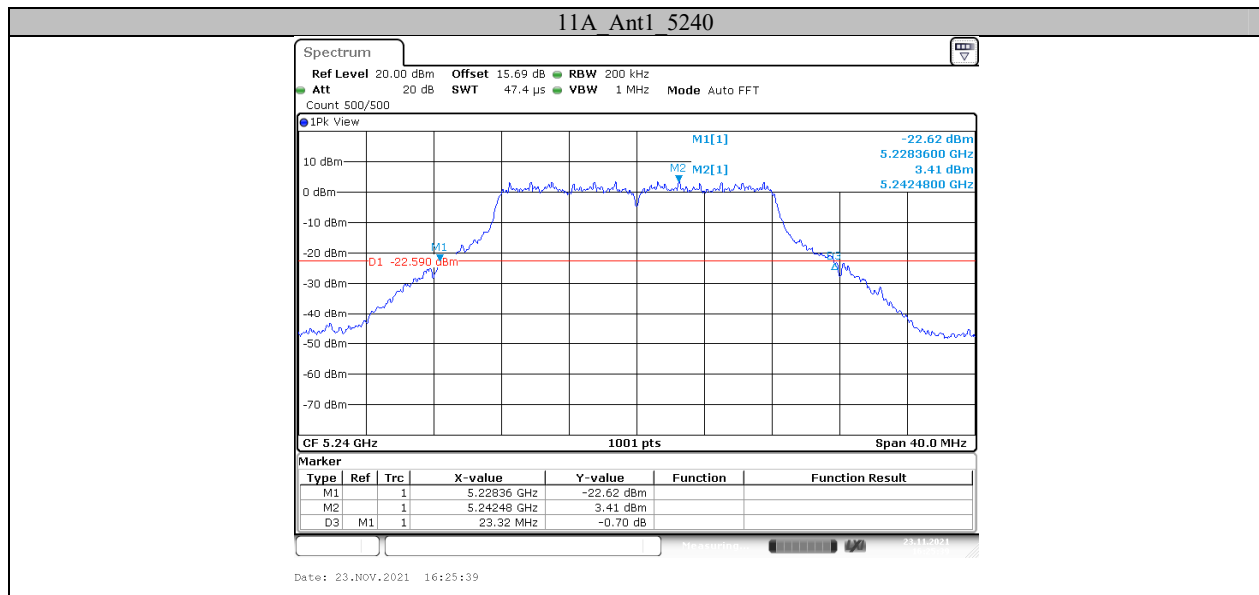

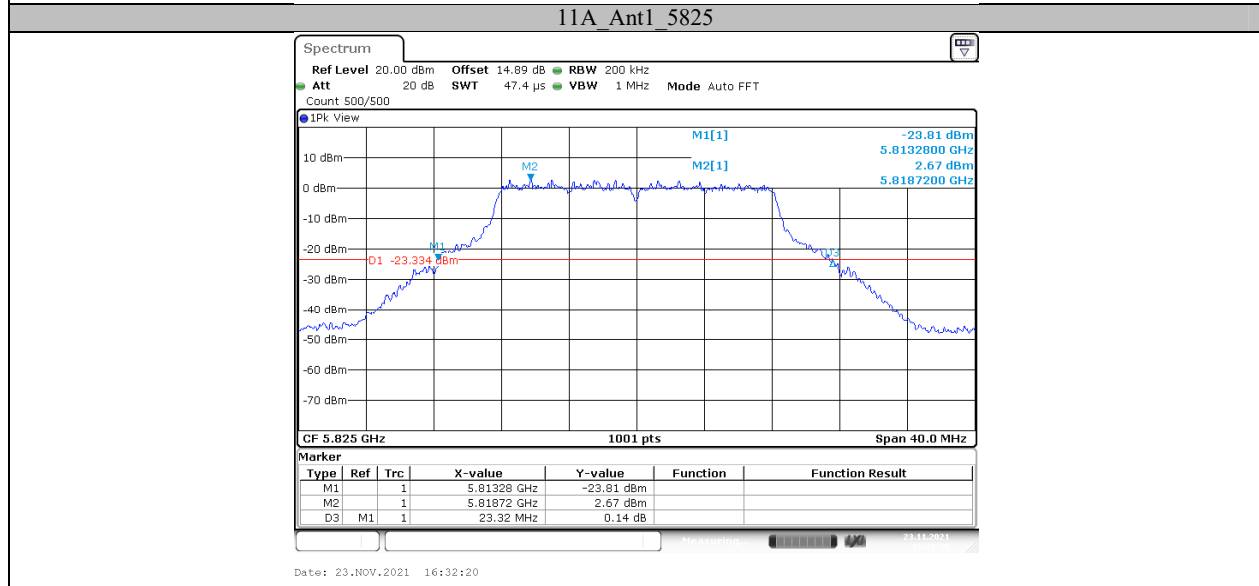
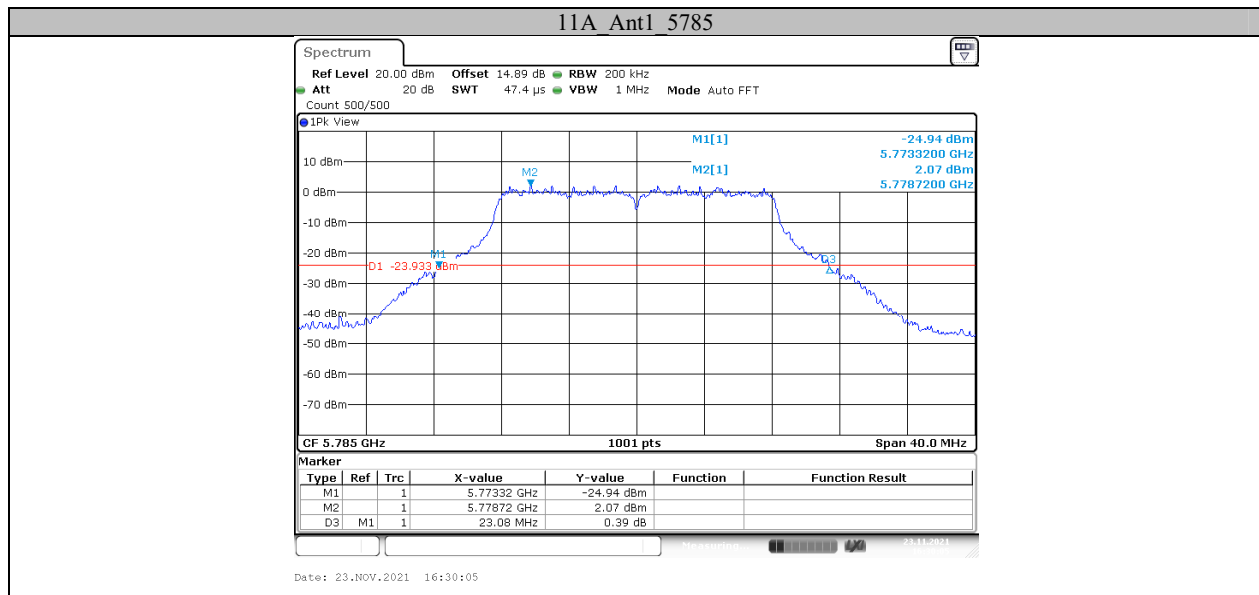

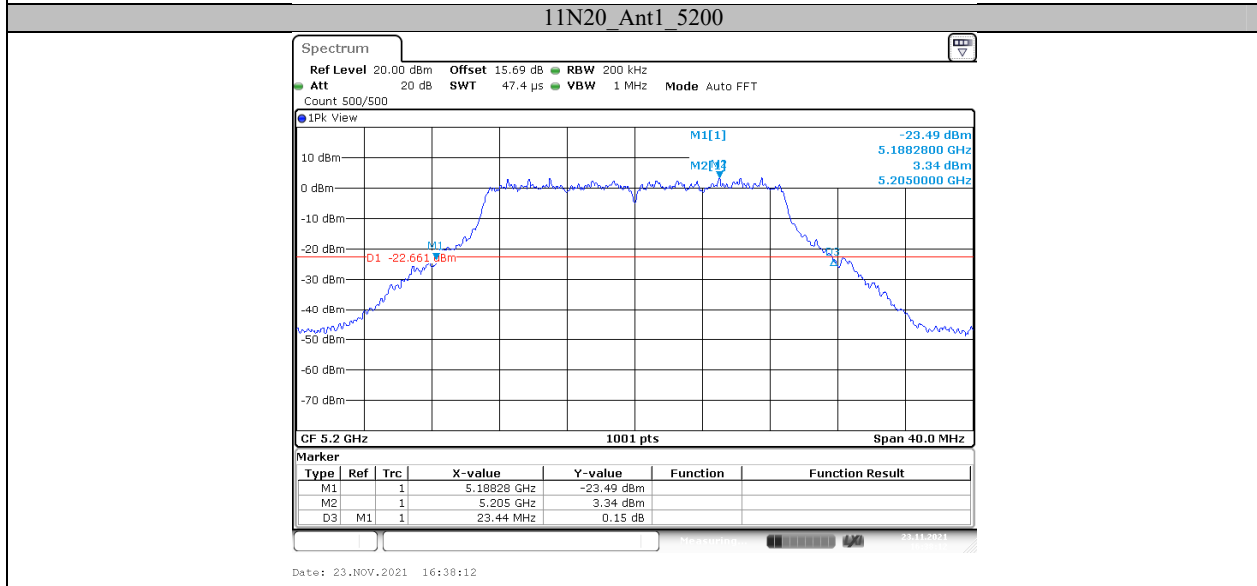
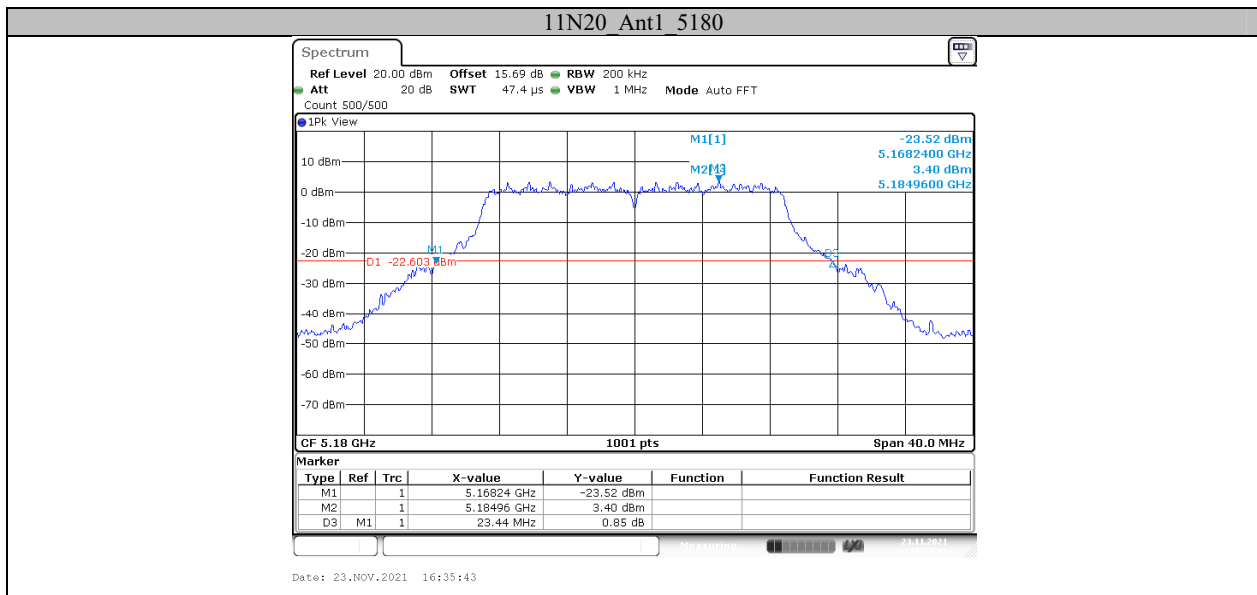

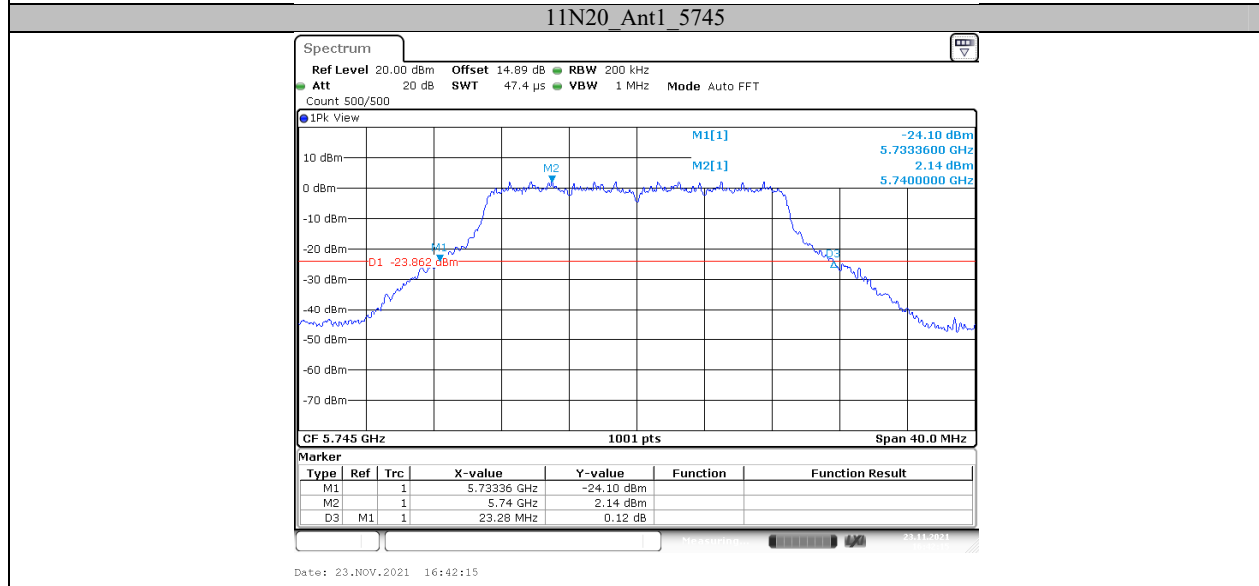
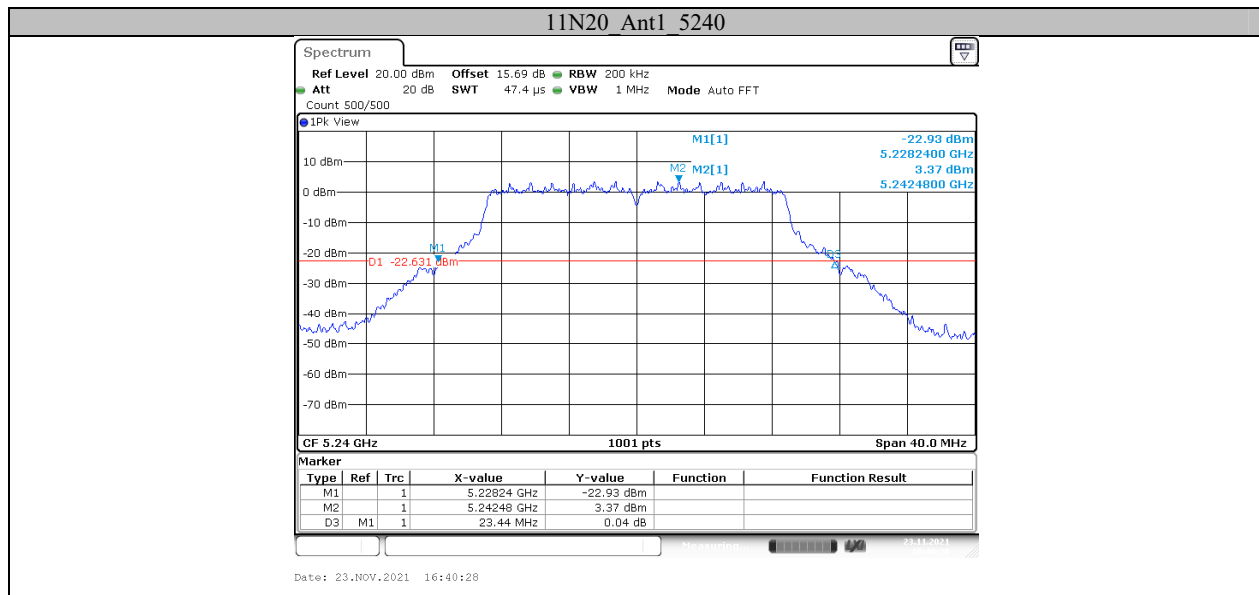

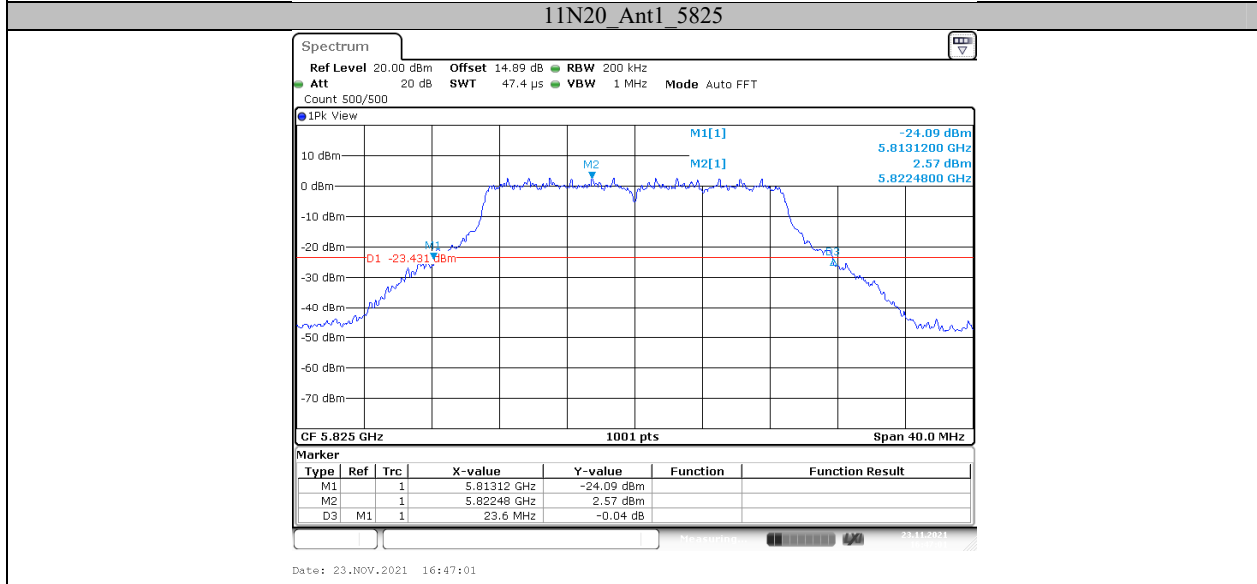
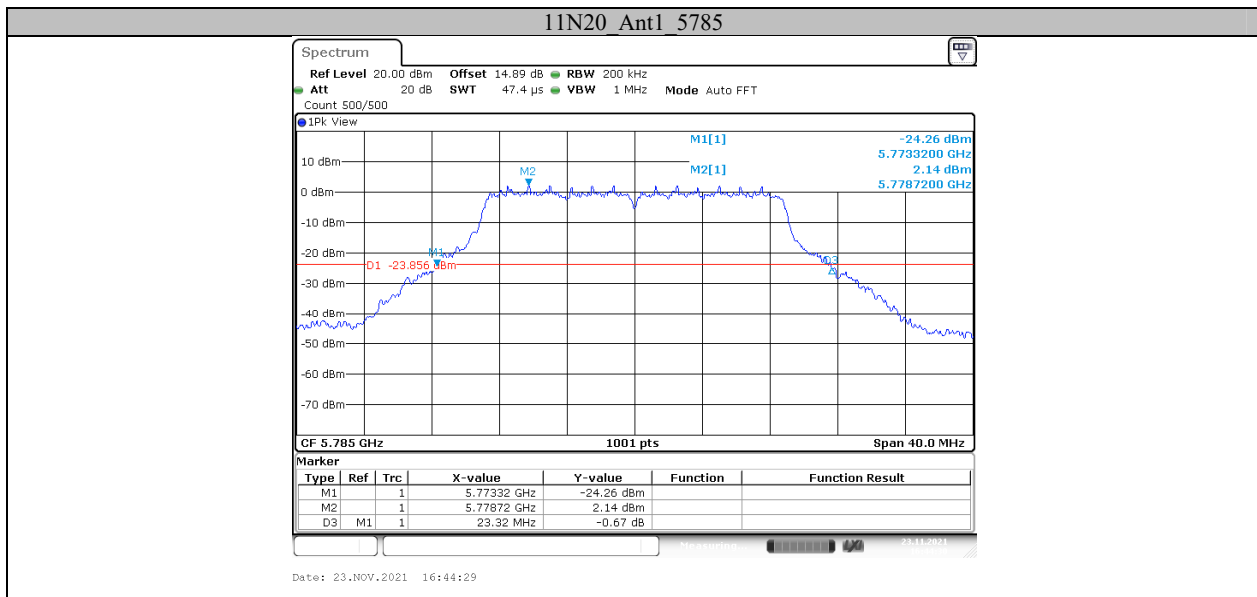

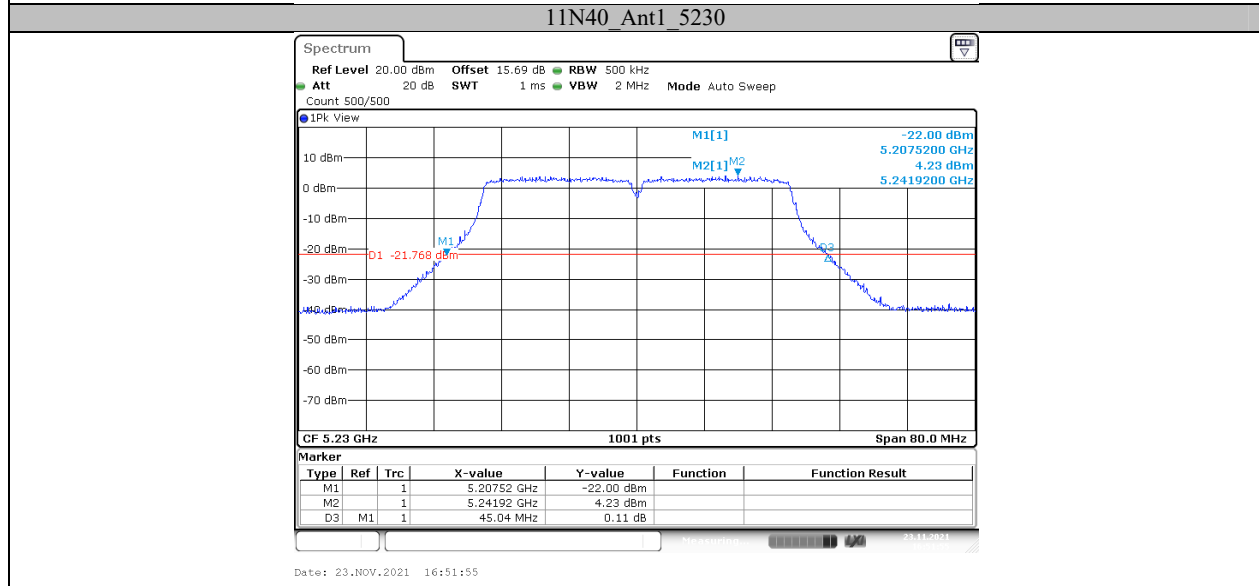
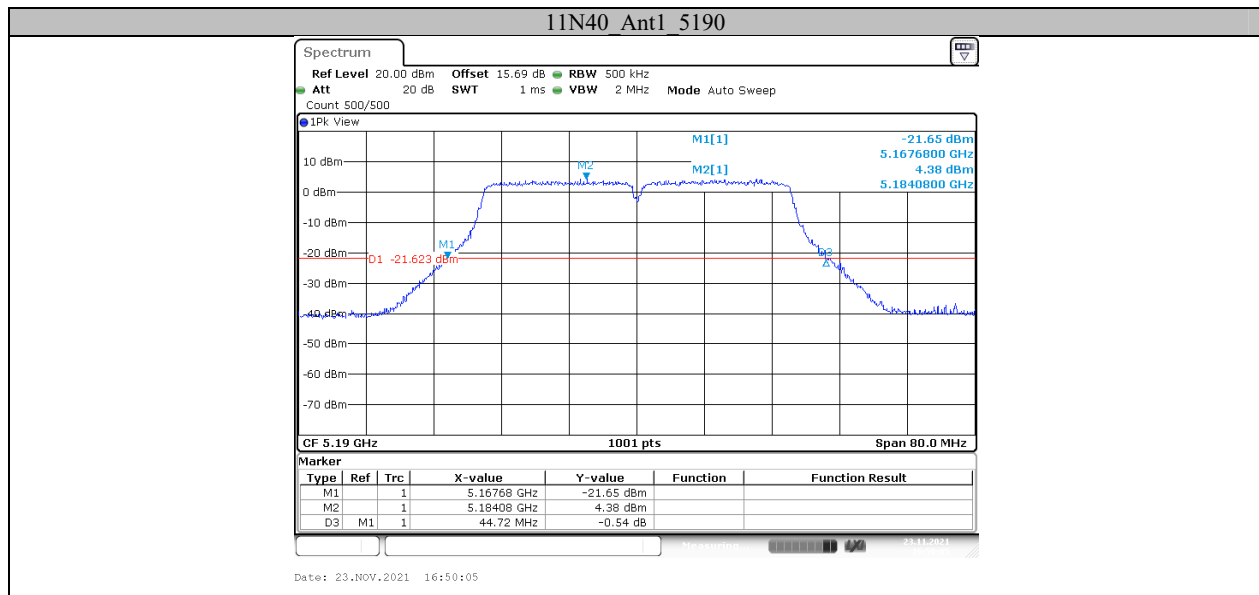

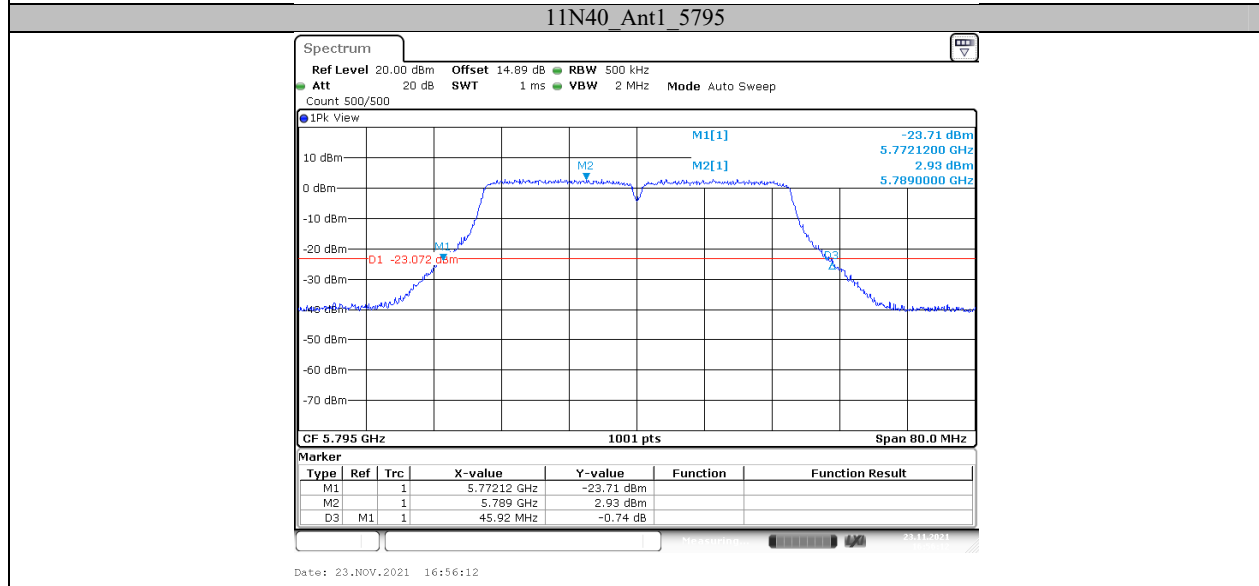
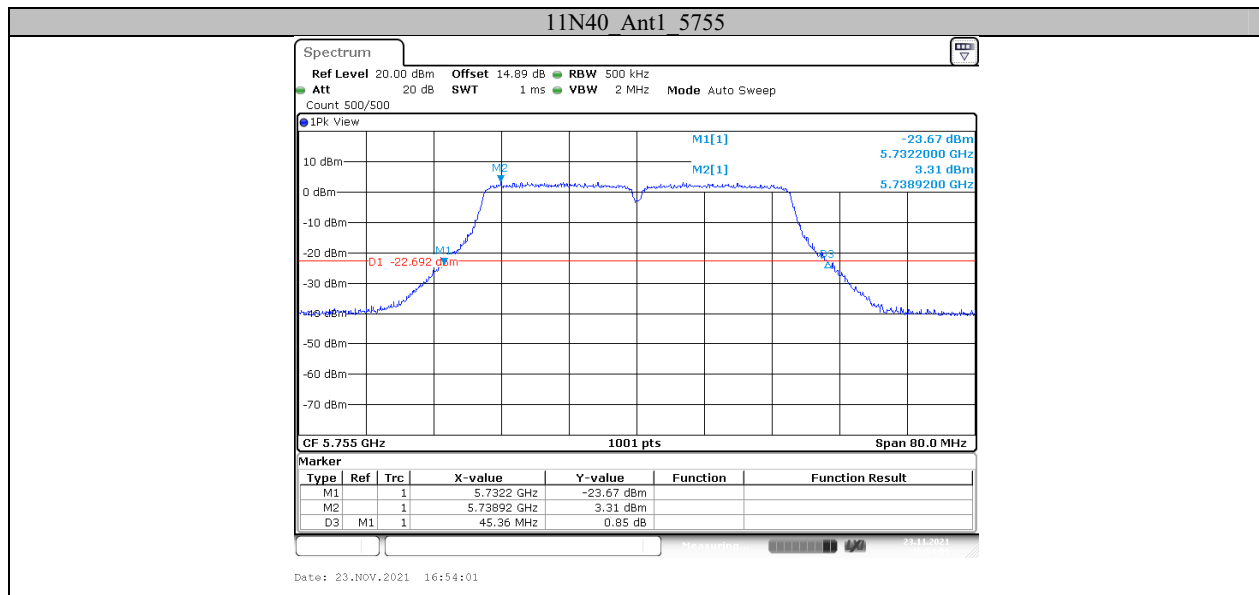

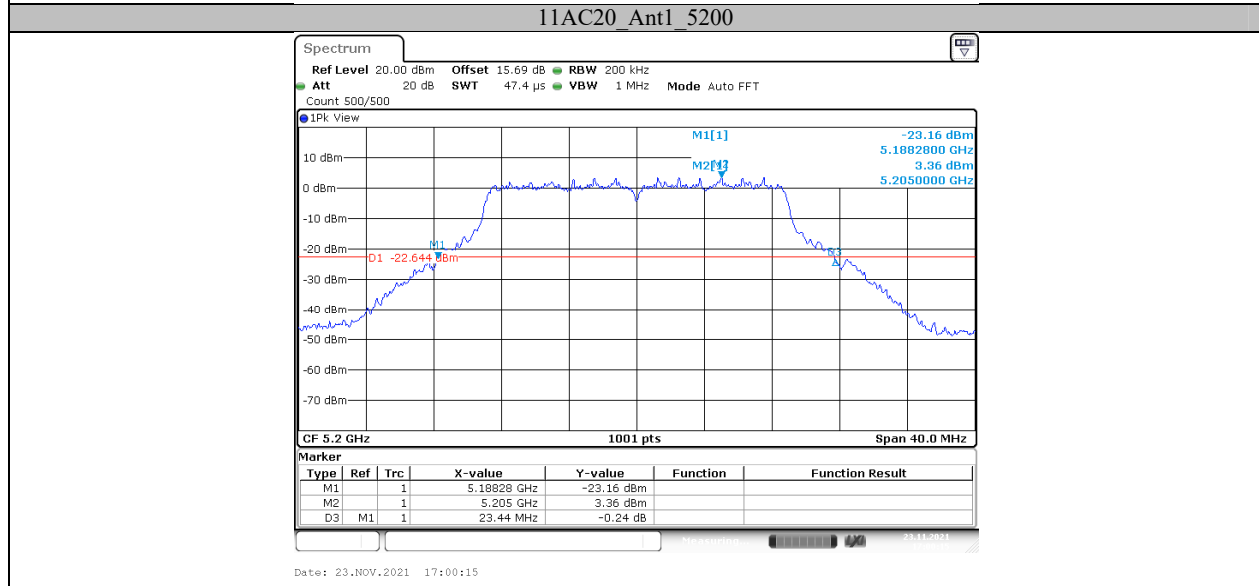
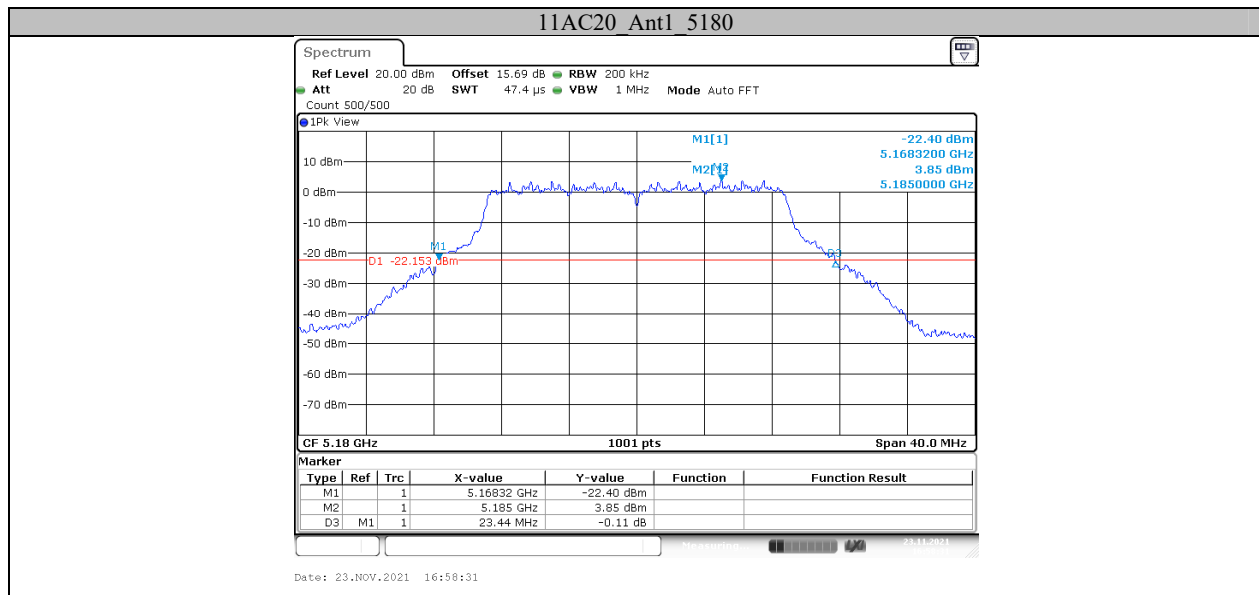

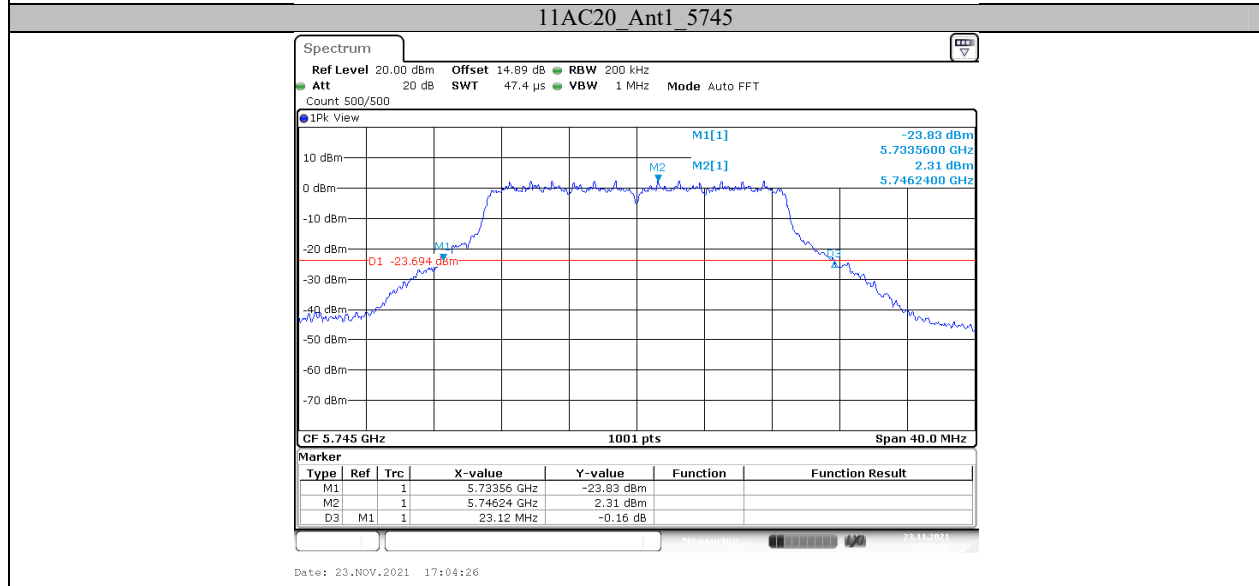
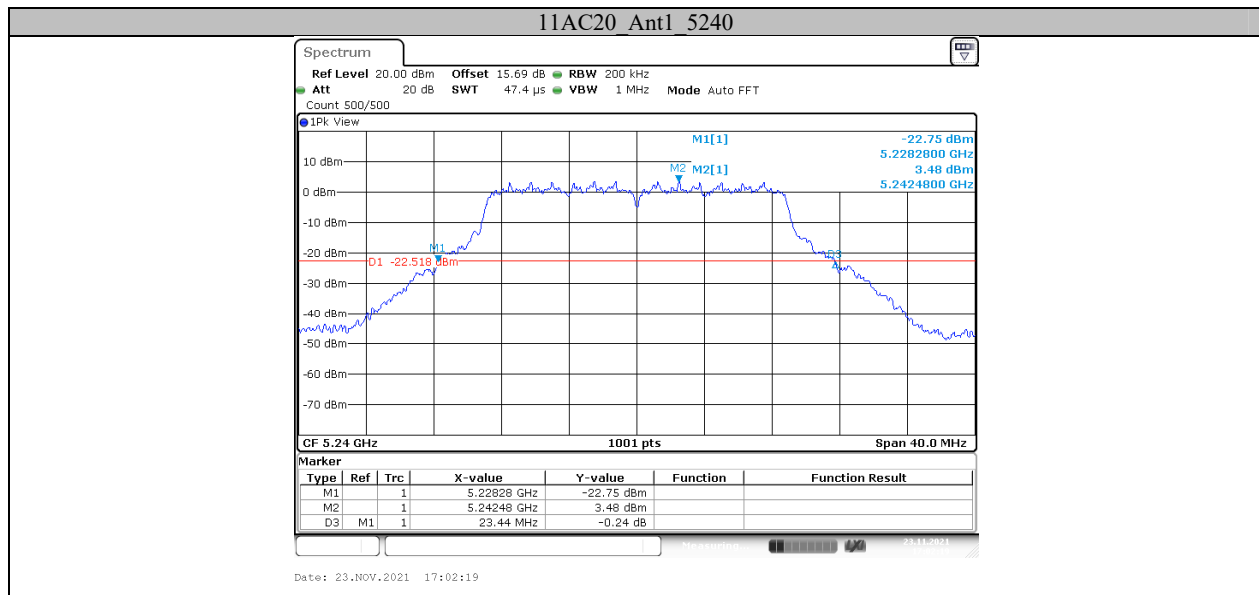

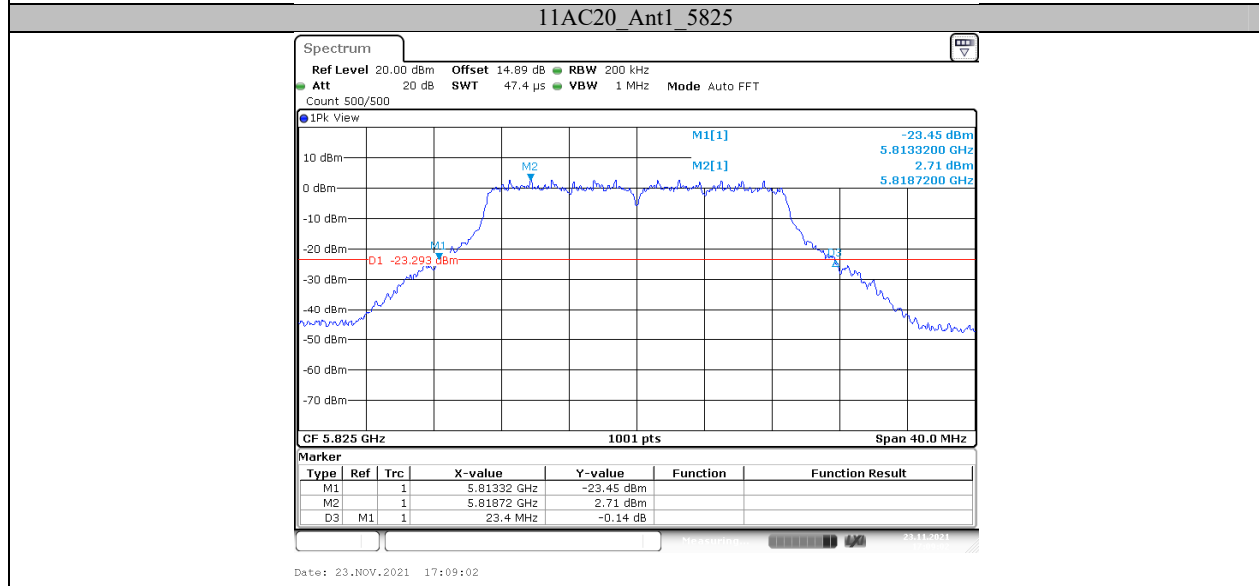
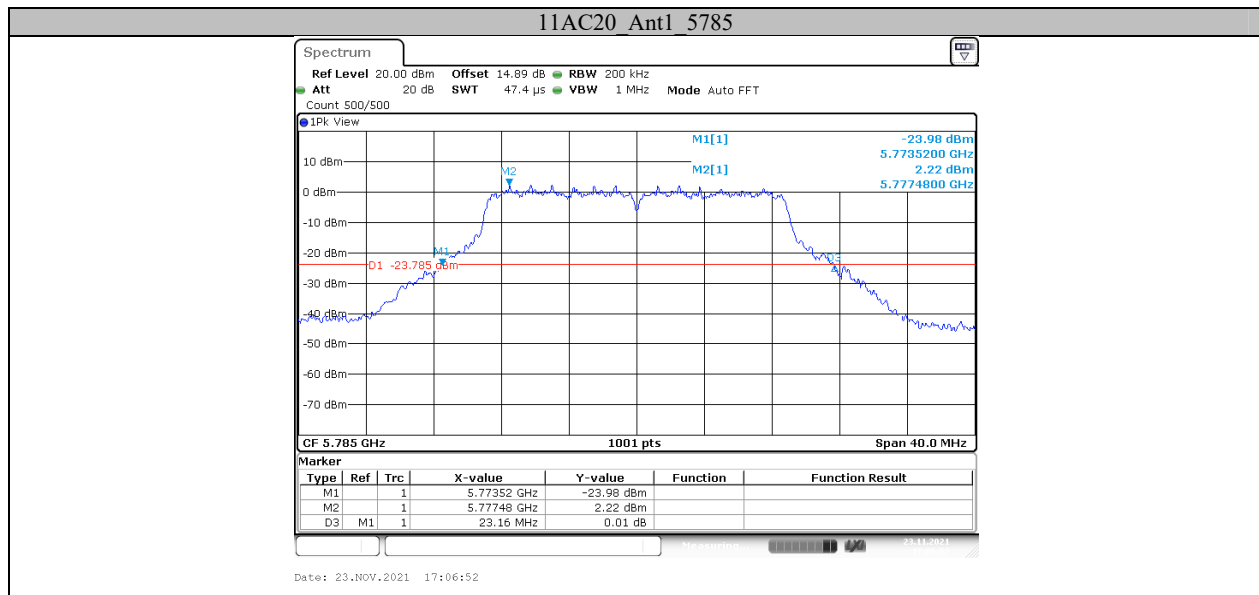

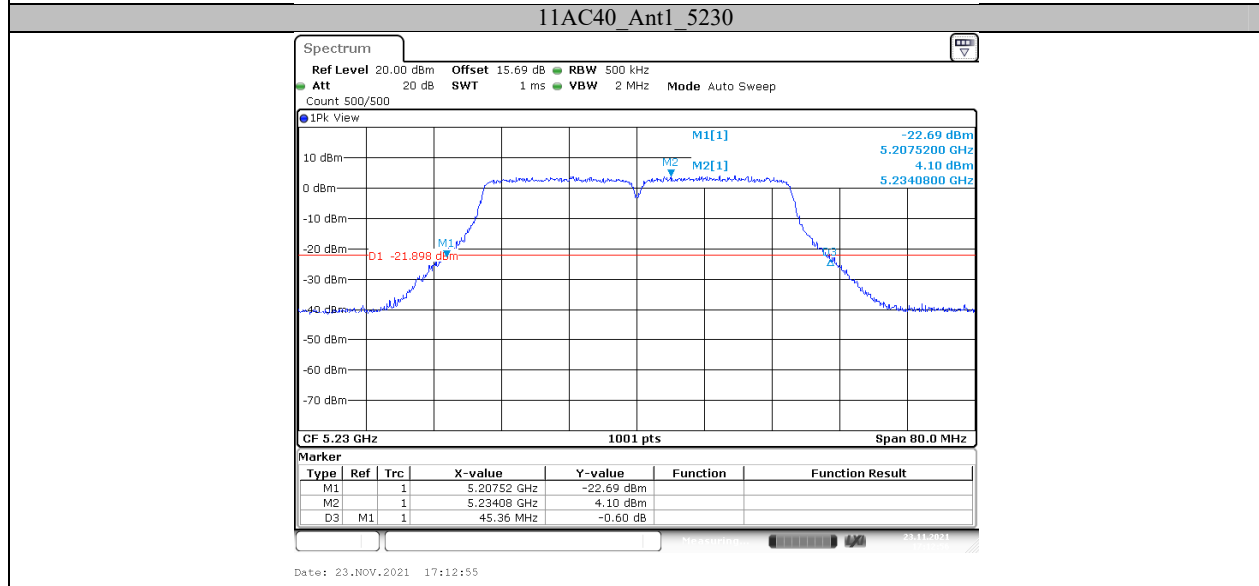
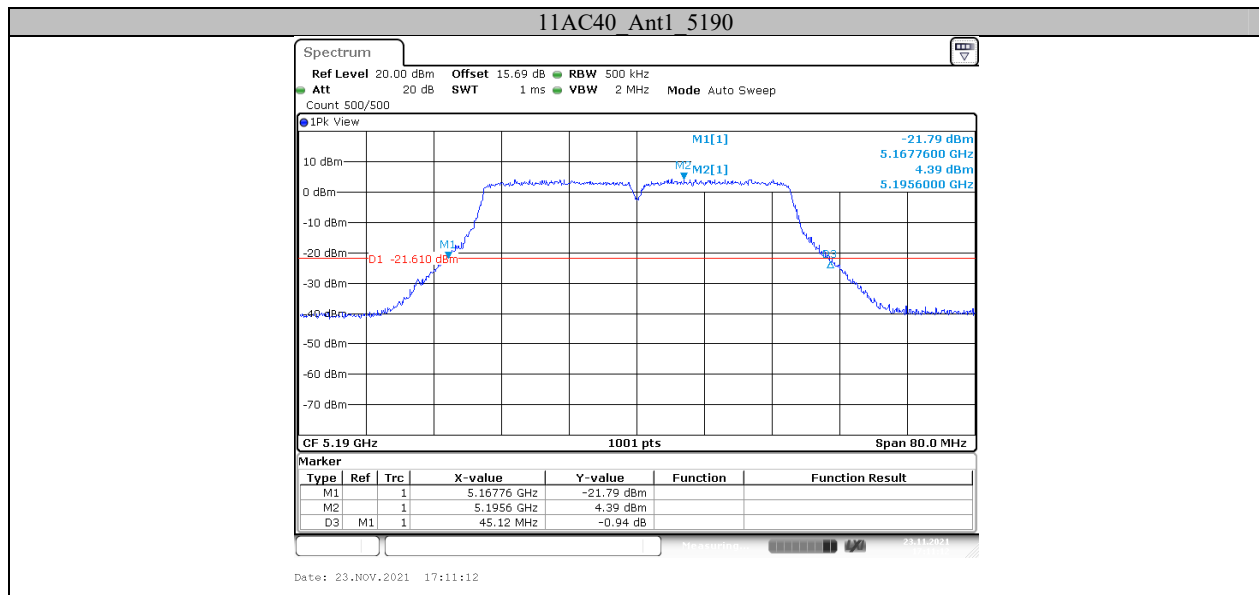

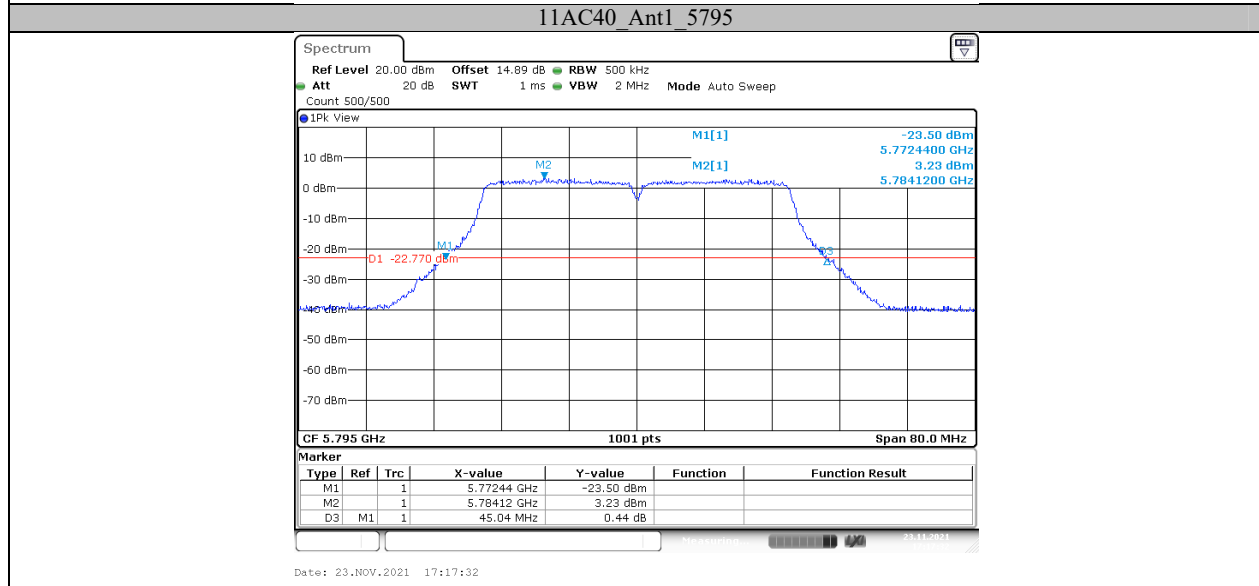
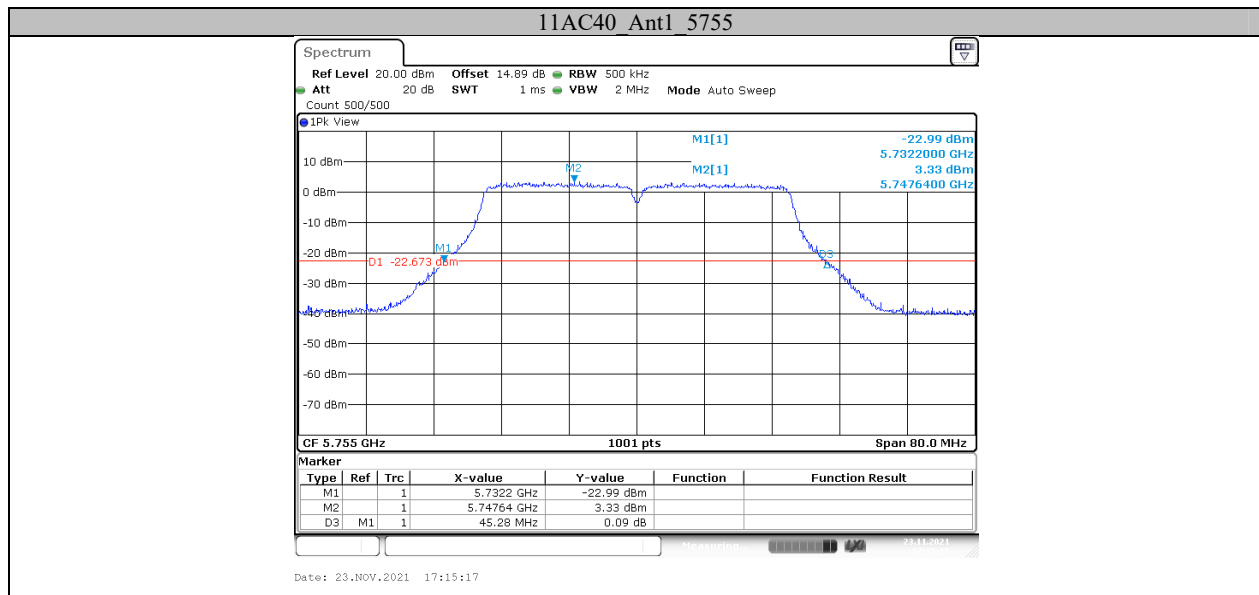

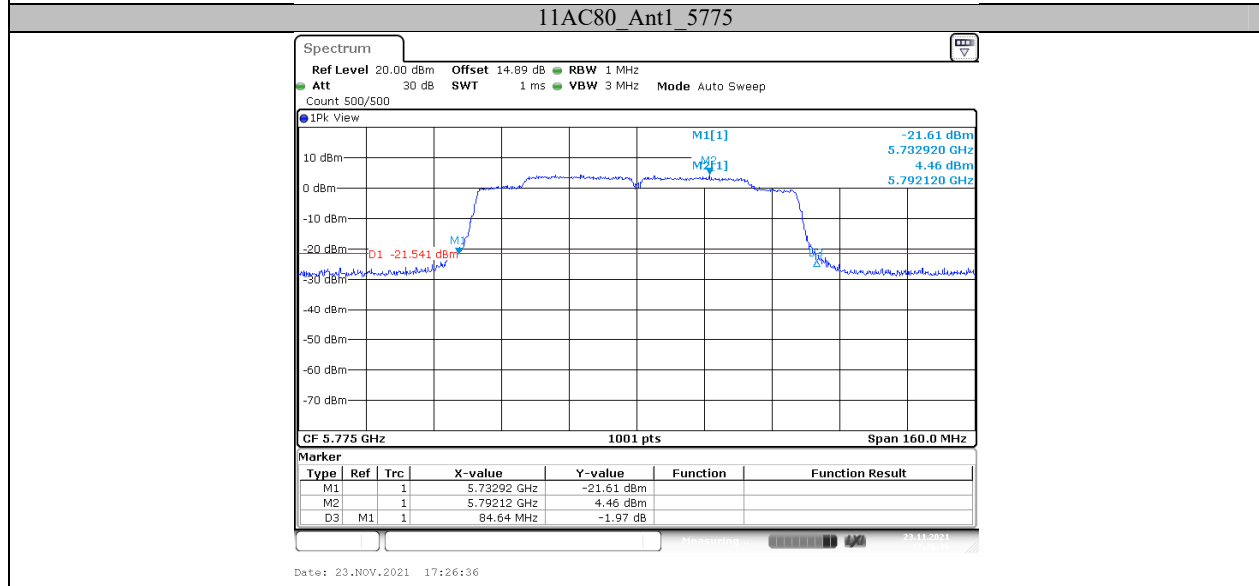
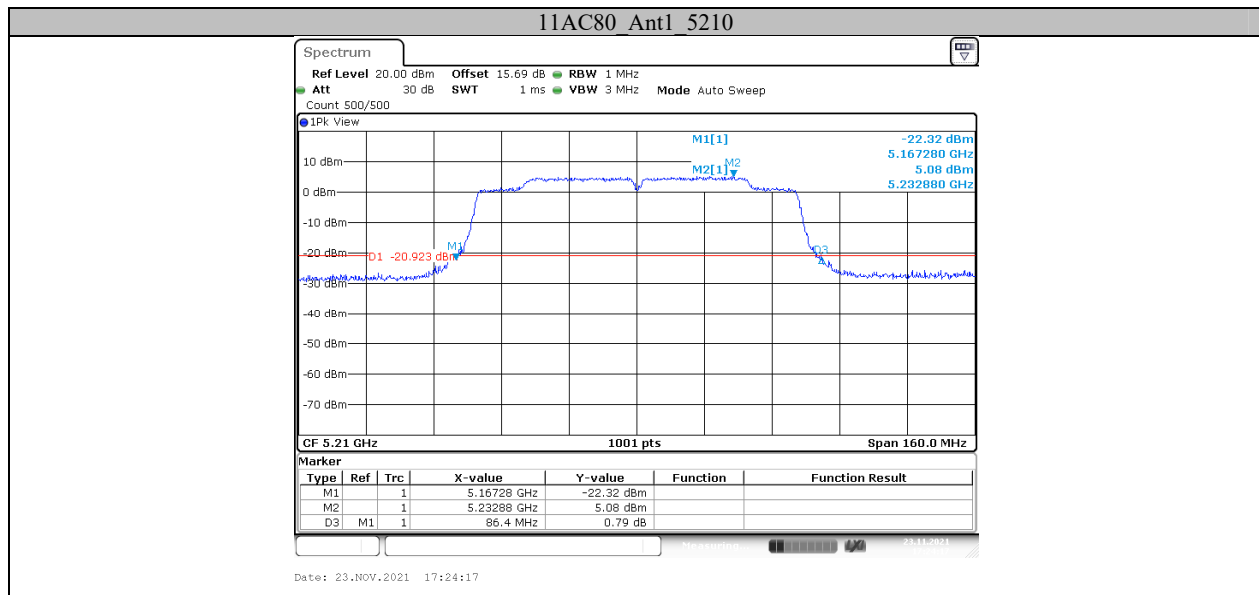

Appendix A2: Occupied channel bandwidth Test Result

TestMode	Antenna	Channel	OCB [MHz]	FL[MHz]	FH[MHz]	Limit[MHz]	Verdict
11A	Ant0	5180	17.622	5171.249	5188.871	---	PASS
		5200	17.702	5191.169	5208.871	---	PASS
		5240	17.662	5231.209	5248.871	---	PASS
		5745	17.702	5736.169	5753.871	---	PASS
		5785	17.702	5776.129	5793.831	---	PASS
		5825	17.742	5816.089	5833.831	---	PASS
11N20	Ant0	5180	18.581	5170.769	5189.351	---	PASS
		5200	18.701	5190.689	5209.391	---	PASS
		5240	18.661	5230.689	5249.351	---	PASS
		5745	18.661	5735.689	5754.351	---	PASS
		5785	18.661	5775.649	5794.311	---	PASS
		5825	18.661	5815.649	5834.311	---	PASS
11N40	Ant0	5190	37.003	5171.618	5208.621	---	PASS
		5230	36.923	5211.618	5248.541	---	PASS
		5755	37.003	5736.459	5773.462	---	PASS
		5795	37.003	5776.538	5813.541	---	PASS
11AC20	Ant0	5180	18.581	5170.769	5189.351	---	PASS
		5200	18.621	5190.729	5209.351	---	PASS
		5240	18.621	5230.729	5249.351	---	PASS
		5745	18.661	5735.689	5754.351	---	PASS
		5785	18.621	5775.689	5794.311	---	PASS
		5825	18.661	5815.649	5834.311	---	PASS
11AC40	Ant0	5190	36.923	5171.618	5208.541	---	PASS
		5230	36.923	5211.618	5248.541	---	PASS
		5755	37.003	5736.538	5773.541	---	PASS
		5795	37.083	5776.459	5813.541	---	PASS
11AC80	Ant0	5210	75.285	5172.438	5247.722	---	PASS
		5775	75.125	5737.438	5812.562	---	PASS

Note: No transmitted signal in the 99% bandwidth extends into the U-NII-2A band and U-NII-2C band.

TestMode	Antenna	Channel	OCB [MHz]	FL[MHz]	FH[MHz]	Limit[MHz]	Verdict
11A	Ant1	5180	17.662	5171.169	5188.831	---	PASS
		5200	17.702	5191.169	5208.871	---	PASS
		5240	17.662	5231.209	5248.871	---	PASS
		5745	17.702	5736.169	5753.871	---	PASS
		5785	17.662	5776.129	5793.791	---	PASS
		5825	17.662	5816.129	5833.791	---	PASS
11N20	Ant1	5180	18.581	5170.769	5189.351	---	PASS
		5200	18.661	5190.689	5209.351	---	PASS
		5240	18.661	5230.729	5249.391	---	PASS
		5745	18.621	5735.729	5754.351	---	PASS
		5785	18.581	5775.689	5794.271	---	PASS
		5825	18.581	5815.689	5834.271	---	PASS
11N40	Ant1	5190	36.923	5171.618	5208.541	---	PASS
		5230	36.923	5211.618	5248.541	---	PASS
		5755	37.003	5736.538	5773.541	---	PASS
		5795	37.083	5776.459	5813.541	---	PASS
11AC20	Ant1	5180	18.621	5170.729	5189.351	---	PASS
		5200	18.701	5190.689	5209.391	---	PASS
		5240	18.661	5230.689	5249.351	---	PASS
		5745	18.661	5735.689	5754.351	---	PASS
		5785	18.661	5775.649	5794.311	---	PASS
		5825	18.621	5815.649	5834.271	---	PASS
11AC40	Ant1	5190	37.003	5171.538	5208.541	---	PASS
		5230	37.003	5211.538	5248.541	---	PASS
		5755	37.003	5736.459	5773.462	---	PASS
		5795	37.003	5776.538	5813.541	---	PASS
11AC80	Ant1	5210	75.285	5172.438	5247.722	---	PASS
		5775	75.285	5737.278	5812.562	---	PASS

Note: No transmitted signal in the 99% bandwidth extends into the U-NII-2A band and U-NII-2C band.

Test Graphs

