

INFIRAY OUTDOOR
RICO HYBRID

Rugged Infrared Compact Optic



WARNING! ITAR REQUIREMENTS

These products may be subject to export and foreign trade control laws of the United States and may not be exported without prior approval of the U.S. Department of State. Learn more at irayusa.com/ITAR.

FCC ID: 2AY3N-HYBRID

This device complies with part 15 of the FCC Rules. Operation is subject to the following two conditions: (1) This device may not cause harmful interference, and (2) this device must accept any interference received, including interference that may cause undesired operation.

CAUTION: Changes or modifications not expressly approved by IRayUSA could void the user's authority to operate the equipment.

NOTE: This equipment has been tested and found to comply with the limits for a Class B digital device, pursuant to part 15 of the FCC Rules. These limits are designed to provide reasonable protection against harmful interference in a residential installation. This equipment generates, uses and can radiate radio frequency energy and, if not installed and used in accordance with the instructions, may cause harmful interference to radio communications. However, there is no guarantee that interference will not occur in a particular installation. If this equipment does cause harmful interference to radio or television reception, which can be determined by turning the equipment off and on, the user is encouraged to try to correct the interference by one or more of the following measures:

- Reorient or relocate the receiving antenna.
- Increase the separation between the equipment and receiver.
- Connect the equipment into an outlet on a circuit different from that to which the receiver is connected.
- Consult the dealer or an experienced radio/TV technician for help.

This device was tested for typical body-supported operations and use. To comply with RF exposure requirements, a minimum separation distance of 0.5cm must be maintained between the user's body and the handset, including the antenna. Third-party belt-clips, holsters, and similar accessories used by this device should not contain any metallic components. Body accessories that do not meet these requirements may not comply with RF exposure requirements and should be avoided. Use only the supplied or an approved antenna.

WARNING: CHOKING HAZARD

Children under 3 years old can choke or suffocate on small parts of this product. This product is not a toy; keep out of reach of children.

TABLE OF CONTENTS

1. Overview	2
2. Features	2
3. Tech Specs	3
4. Accessories	4
5. Components and Controls	5
6. Description of Control Buttons & Shortcuts ...	6
7. Quick Start Guide	8
8. Charging the Battery Pack	10
9. Installing the Battery Pack.....	11
10. Removing the Battery Pack.....	12
11. Battery Safety Warnings	12
12. External Power Supply	13
13. Mounting the RICO HYBRID	14
14. Operating Instructions	15
15. Zeroing the RICO HYBRID	22
16. Non-Uniformity Correction.....	23
17. Photography and Video Recording	24
18. Accessing the Internal Memory	26
19. Using the InfiRay Outdoor App	27
20. Digital Zoom	28
21. Picture in Picture (PIP).....	28
22. Region of Interest (ROI)	29
23. Clip-On Mode	29
24. Adjusting Clip-on Mode Screen Position	29
25. BDC Reticle	31
26. Main Menu Options and Descriptions	32
27. Basic Inspection	52
28. Basic Maintenance	52
29. Warranty.....	52
30. General Troubleshooting	53
31. Notes	56

1. OVERVIEW

The InfiRay Outdoor RICO HYBRID HYL50W fuses the capabilities of a thermal clip-on and a thermal weapon sight to create a new breed of thermal device. The HYBRID gives you never-before-seen versatility and performance, boasting a 2,000 yard detection range as a dedicated thermal sight, or compatibility with day optics up to 10× as an inline clip-on sight. The combination of the HYBRID’s low-distortion orthoscopic eyepiece and a 1.03-inch large-format 2560×1920 AMOLED display provides comfortable viewing as a dedicated sight while still maintaining the pixel density and resolution for use as a clip-on optic. The HYBRID also unlocks advanced features such as compatibility with a 1,000 yard laser rangefinder, a custom reticle generator, and an onboard ballistic solver.

2. FEATURES

- 17µm high-performance thermal detector
- ≤25 mK sensitivity
- High image quality
- Magnesium housing
- Quick-change rechargeable battery pack
- Maximum detection range 2000 yards
- HD 2560×1920 AMOLED display with low-distortion eyepiece
- High frame frequency: 50Hz/90Hz
- Compatible with ILR-1000-2 Laser Rangefinder Module (optional/not included)
- Recoil activated video
- Advanced recoil-mitigating mount for improved accuracy
- Multiple reticle types and color options
- Onboard ballistic solver and BDC reticle
- Standalone and clip-on optic modes
- Multiple zero profiles and ranges
- Digital Zoom: ×1/×2/×4/×8
- Built-in 64 GB storage to support image capture and video recording
- Built-in Wi-Fi module
- Mobile device App compatible
- ROI (Region of Interest) mode
- Built-in digital compass and gravity sensor
- Picture in Picture (PIP)
- User-friendly interface
- Pixel calibration functions

3. TECH SPECS

RICO HYBRID	HYL50W
SENSOR	
Resolution	384×288
Pixel Size	17 µm
Frame Rate	50Hz/90Hz
Sensor Sensitivity	≤25 mK
Image Processing	MATRIX III
Core	InfiRay Micro II 384
OPTICS	
Objective Lens	50 mm f/1.0
Magnification	2.5×
Digital Zoom	8×
Field of View	7.5° × 5.6°
Detection Range	2000 Yards
Display Type	1.03-inch Large-format AMOLED
Display Resolution	2560×1920
Color Palettes	White Hot, Black Hot, Red Hot, Iron Red, Rainbow, Outline
Reticle Types	9 (7 Static, 1 DIY, 1 BDC)
Reticle Colors	Black, White, Red, Green, Blue
Mounting System	
P.I.P.	Yes
Rangefinder	ILR-1000-2 LRF (Optional/Not Included)
Eye Relief	60 mm
Diopter Range	-4 to +2
ELECTRONICS	
Onboard Recording	Video, Recoil-Activated Video, and Image
Onboard Storage	64 GB
Wireless Connectivity	Image and Video via App.
Data/Power Connector	USB-C
Power Supply	USB-C External, IBP-1H Li-ion Battery Pack (12 Hours)
Start Up Time	<10 Seconds, Instant from Standby
PHYSICAL	
Size	11.02" × 3.03" × 2.99"
Weight	30.08 Oz
ENVIRONMENTAL/WARRANTY	
Warranty	5 Years
Housing Material	Aluminum
Ingress Protection	IP67
Operation Temperature	-4°F~122°F
Max. Recoil	1000 g/s ² (300 Win./7mm Mag)

4. ACCESSORIES

The RICO HYBRID HYL50W rifle scope ships with everything you need to get out and hunt.

- Hybrid Thermal Imaging Scope
- Advanced Recoil-Mitigating Picatinny Mount for RICO HYBRID
- Adapter Bracket
- Battery 4400 mAh
- Battery Charger
- 4-in-1 Power Adapter
- USB-C Data Cable
- Tool Carton
 - Hex Key 2.5mm, 3mm
 - Screws for Mount (m3×10, m5×6)
 - Leather Rail Adjustment Wrench
- Bluetooth Remote Control
- Heated Target×5
- Lens Cloth
- User Manual
- Infray Sticker×2
- Infray Card



Optional accessories, such as the Advanced Recoil-Mitigating Picatinny Mount and ILR-1000-2 Laser Rangefinder Module, as well as various replacement accessories, are available for purchase. Contact 800-769-7125 or irayusa.com/support.

5. COMPONENTS AND CONTROLS

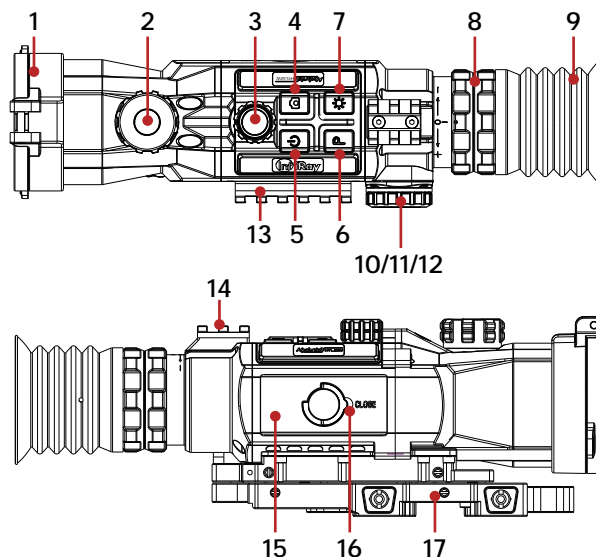

- 1 Objective Lens Cap
- 2 Objective Lens Focus Knob
- 3 Rotary Encoder
- 4 Photo Button
- 5 Power Button
- 6 Palette Button
- 7 Display Brightness Button
- 8 Eyepiece / Diopter Adjustment Ring
- 9 Eyeguard
- 10 USB-C Cover
- 11 USB-C Port
- 12 Battery Indicator LED
- 13 Side Accessory Rail
- 14 Top Accessory Rail
- 15 IBP-1H Battery Pack
- 16 Battery Pack Pull-Ring
- 17 Advanced Recoil-Mitigating Picatinny Mount

6. DESCRIPTION OF CONTROL BUTTONS AND SHORTCUTS





Power Button 		
Current Screen, Menu, or Device Status	Short Press	Long Press
Device off	---	Power on the device
Home screen	Perform a non-uniformity correction (NUC)	Power off the device / enter standby mode
Main menu	Return to previous menu without saving changes	---
In standby mode	Exit standby	---
Reticle zeroing interface	Deselect current axis of movement; exit interface without saving	---

Photo Button 		
Current Screen / Menu	Short Press	Long Press
Home screen	Take photo	Start / stop recording video

Palette Button 		
Current Screen / Menu	Short Press	Long Press
Home screen	Adjust the imaging mode	Adjust the color palette

Brightness Button 		
Current Screen / Menu	Short Press	Long Press
Home screen	Adjust the display brightness	Turn PIP window on / off

NOTE: Consult the manual that comes with your ILR-1000-2 Laser Rangefinder Module (optional/not included) for rangefinder shortcuts.

Brightness + Photo Button  + 		
Current Screen / Menu	Short Press	Long Press
Home screen	Turn ROI feature on / off	---
Reticle zeroing interface	---	Freeze image to keep reticle centered on aiming point; press again to clear
Home screen (in clip-on mode only)	---	Enter the clip-on mode screen adjustment interface

Rotary Encoder			
Current Screen / Menu	Short Press	Long Press	Rotate
Home screen	Enter quick menu	Enter main menu	Adjust digital zoom level
Quick menu	Enter the submenu; confirm submenu changes and return to the previous menu level	Save changes and exit to home screen	<p>All menus and submenus: Move through menu options;</p> <p>Defective pixel correction, file management, and reticle zeroing interfaces: Switch between interface options; move reticle or cursor position</p> <p>Clockwise: Move right / up</p> <p>Counterclockwise: Move left / down</p>
Main menu			
Reticle zeroing interface	Select or deselect the axis of movement (X or Y)		
File management, clip-on mode screen adjustment, & defective pixel correction interfaces	Select or deselect an interface button		

Rotary Encoder + Brightness Button 		
Current Screen / Menu	Short Press	Long Press
Settings menu	---	Activate / deactivate reticle

Rotary Encoder + Photo Button 		
Current Screen / Menu	Short Press	Long Press
Home screen	---	Enable / disable clip-on mode

7. QUICK START GUIDE

Step 1: Prepare to Use the RICO HYBRID

1. Compare the box contents to the accessories list and examine each for any shipping damage. See **Accessories** on page 4.
2. Check the lens to ensure there are no smudges or dirt present. Clean with the included lens cloth, if necessary.
3. Charge the battery (15). See **Charging the Battery Pack** on page 10.
4. Install the eyeguard (9).
5. Mount the RICO HYBRID to the weapon. See **Mounting the RICO HYBRID** on page 14.

Step 2: Turn On the RICO HYBRID

1. Open the objective lens cap (1).
2. Long press the **Power**  **Button** for 3 seconds to power on the RICO HYBRID. The InfiRay Outdoor logo will appear.
3. Rotate the diopter adjustment ring (8) of the eyepiece until the interface icons are clearly visible.

WARNING: Do not point the objective lens toward intense energy sources, such as the sun. This may render the electronic components inoperative. The warranty does not cover damage caused by improper operation.

Step 3: Adjust Settings in the Quick Menu

Short press the **Rotary Encoder** to enter the quick menu to adjust the following settings (see **Using the Quick Menu** on page 19):

1. Set the image brightness level, from 0–9.
2. Set the image contrast level, from 0–9.
3. Set image sharpness level, from 0–9.
4. Set the non-uniformity correction (NUC) mode to automatic (a), manual (m), or background (b).
5. Select the reticle type, 1–7 or the DIY reticle.
6. Set the reticle color to white, black, red, green, or blue.
7. Select a zero distance from the three preset options.
8. Select the frame rate type, from 50Hz/90Hz.

Step 4: Adjust Device Settings in the Main Menu

1. Long press the **Rotary Encoder** to enter the main menu (see **Main Menu Options and Descriptions** on page 32 for detailed instructions) to:
 - a. Turn on the digital compass.
 - b. Set the photo mode to single shot, burst, or self-timer.

- c. Set the image temperature to cool or warm.
 - d. Calibrate the digital compass.
 - e. Turn on the microphone.
 - f. Turn on the recoil activated video.
 - g. Set the date and time.
 - h. Set the unit of measure to meters or yards.
2. From the home screen:
 - a. Rotate the **Rotary Encoder** to zoom in and out on the observed object.
 - b. Long press the **Palette**  **Button** to set the color palette to white hot, black hot, red hot, iron red, rainbow, or outline.
 - c. Short press the **Palette**  **Button** to set the imaging mode to clear, highlight, or fog.
 - d. Short press the **Brightness**  **Button** to set the display brightness level, from 0–10. A brightness  icon and indicator bar appear in the lower-left corner of the screen.
 - e. Long press the **Brightness**  **Button** to turn on the PIP window. See **Picture in Picture (PIP)** on page 28.

Step 5: Activate the Reticle

The reticle may be inactive when the RICO HYBRID is powered on for the first time. To activate the reticle, or to deactivate it at a later time:

1. From the home screen, long press the **Rotary Encoder** to enter the main menu.
2. Rotate the **Rotary Encoder** to move to the settings menu item.
3. Short press the **Rotary Encoder** to enter the settings submenu.
4. Long press the **Rotary Encoder** and the **Brightness**  **Button** at the same time for 3 seconds to activate the reticle and hidden reticle and zeroing menu items.

Step 6: Zero the RICO HYBRID

1. Zero the rifle scope. See **Zeroing the RICO HYBRID** on page 22.
 - a. Select the zeroing profile, A, B, or C.
 - b. Select the ballistics profile, 1, 2, or 3.
 - c. Select, or customize, a preset zero distance that matches the target distance.
 - d. Zero the reticle.

8. CHARGING THE BATTERY PACK

The RICO HYBRID rifle scope comes with a long-lasting rechargeable lithium-ion battery pack, which allows for 12 hours of operation. The IBP-1H battery pack uses a cam-locking mechanism to ensure quick and secure battery changes in the field. Fully charge the battery pack before using the RICO HYBRID for the first time.

Charging with the Battery Charger

1. Insert a battery pack (15) into the battery charger (18). Align the slots (A) on the edge of the battery pack with the pins (B) on the inside of the charger.
2. Connect the small USB-C end of the data cable (19) to the USB-C port (C) on the battery charger.
3. Connect the standard USB end of the data cable to:
 - a. The included 5V–2A USB power adapter; OR
 - b. Any standard USB 3.0 port on a laptop/computer.
4. During charging, the LED status indicator (D) on the battery charger will be solid red.

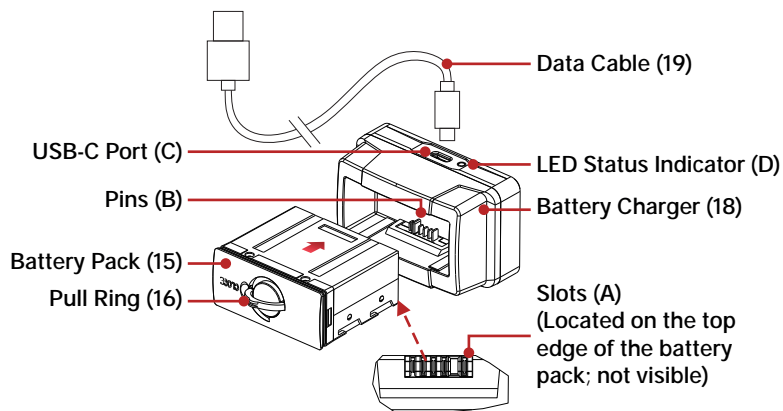

5. When fully charged, remove the battery pack from the battery charger.
 - a. The LED status indicator will turn solid green when the battery is fully charged. Do not overcharge.

NOTE: When the LED status indicator flashes red, the battery charger is connected to a power source but no battery pack is installed.

WARNING: Never use the battery charger with a USB power adapter that is greater than 5V–2A.

Charging via the USB-C Port

1. Open the USB-C cap.
2. Connect the small USB-C end of the data cable (19) to the USB-C port (11) on the side of the RICO HYBRID.
3. Connect the standard USB end of the data cable to:
 - a. The included 5V–2A USB power adapter; OR
 - b. Any standard USB 3.0 port on a laptop or computer; OR
 - c. An external power supply, such as a USB power bank.
4. During charging:
 - a. The battery indicator LED (12) next to the USB-C port is red during charging.
 - b. In the status bar, the battery status (50) icon which shows the current battery percentage, alternates with the battery charging (🔋) icon.
5. When fully charged, disconnect the charging cable.
 - a. The battery indicator LED (12) will turn green when the battery is fully charged. Do not overcharge.

NOTES:

- You may charge and operate the RICO HYBRID at the same time.
- The battery status (50) icon turns red when the battery is below 20%; charge right away to avoid over-discharge and a reduction in battery capacity or service life.

9. INSTALLING THE BATTERY PACK

1. Lift the pull-ring (16) on the battery pack (15) and rotate it clockwise 90 degrees until it is horizontal to the battery pack.
2. Position the battery pack face up with the slots (A) facing up.
3. Align the slots (A) on the edge of the battery pack with the pins (B) on the inside of the battery compartment of the RICO HYBRID, then slide the battery pack into the opening.

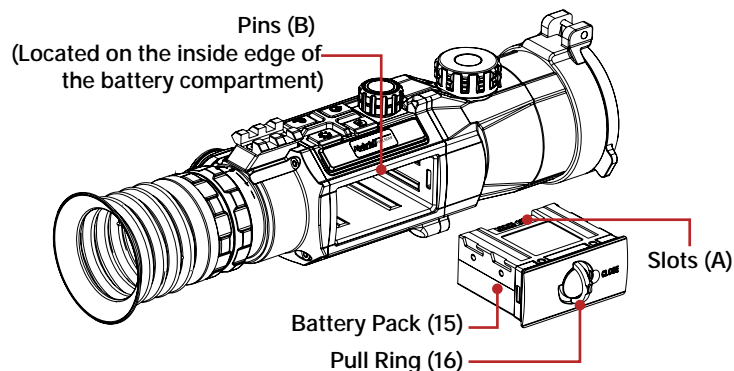

4. Firmly press the battery in to fully insert it.
5. Rotate the pull-ring counterclockwise 90 degrees to the vertical position to lock the battery pack in place.
6. Flip the pull-ring down so that it is flush with the battery pack.

WARNING: The RICO HYBRID can only be powered by a factory-supplied IBP-1H battery pack. Using any other battery pack may cause irreparable damage to the rifle scope or cause a fire. Any damage from using an improper battery pack will not be covered by warranty.

10. REMOVING THE BATTERY PACK

1. To remove the battery pack from the RICO HYBRID:
 1. Lift the pull-ring (16) on the battery pack (15) and rotate it clockwise 90 degrees until it is horizontal to the battery pack.
 2. Pull the battery pack out.

11. BATTERY SAFETY WARNINGS

WARNING: Only use the battery charger supplied with the battery pack. The use of any other charger may irreparably damage the battery pack or the charger and may cause a fire. Any damage from using an improper battery charger will not be covered by warranty.

WARNINGS:



- Do not use a battery charger, power adapter, or USB cable that has been modified or damaged.
- Do not expose the battery to high temperatures or flames, and do not immerse in water.
- Do not leave the battery unattended while charging.
- Do not leave the battery in the charger for long periods after full charge is reached. Charging time should not exceed 24 hours.
- Keep the battery pack out of the reach of children and pets.
- The battery is equipped with short-circuit protection. However, any situation that may cause short-circuiting should be avoided.
- Do not disassemble, modify, hit, or drop the battery pack.
- Do not connect the battery to any external device with an electrical current that exceeds permitted levels.
- Do not connect an external device with a current supply that exceeds a 3.0 USB port.

To maintain optimal battery capacity and service life:

- Avoid storing a fully charged or discharged battery for long periods. Partial charging of the battery is necessary if the battery will be stored for an extended period.
- Do not charge an extremely cold battery without bringing it into a warm environment. Let the battery warm up for 45 minutes before charging.
- Charge the battery at a temperature range from 32°F to 113°F; otherwise, the service life of the battery may be reduced.
- The recommended operating temperature range is -4°F to 122°F. Avoid using the battery above the maximum or below the minimum recommended temperature range as this may decrease the battery capacity or service life.

12. EXTERNAL POWER SUPPLY

The RICO HYBRID supports the use of a 5V external power supply, such as a mobile power bank. To connect to an external power supply:

1. Open the USB-C cover (11).
2. Connect the small USB-C end of the data cable (19) to the USB-C port (11) on the side of the RICO HYBRID.
3. Connect the other end of the data cable to the external power supply.
4. The RICO HYBRID will switch to operation from the external power supply, and the internal battery pack will begin slowly charging.
5. In the status bar, the battery status  icon will alternate with the battery charging  icon.
6. If the external power supply is disconnected, the RICO HYBRID will automatically switch to the battery pack, if installed, without powering off.

NOTE: Do not connect the RICO HYBRID to an external device with a power supply that exceeds the 3.0 USB cable.

13. MOUNTING THE RICO HYBRID

Installing the Mount

Before using the RICO HYBRID, install the Advanced Recoil-Mitigating Picatinny Mount (17) to the mount interface on the base of the RICO HYBRID.

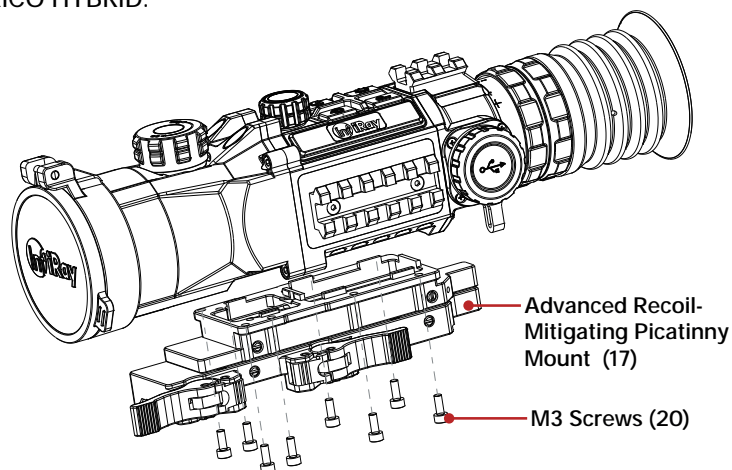

1. Install the Advanced Recoil-Mitigating Picatinny Mount (17) to the base of the RICO HYBRID using a 2.5mm hex key and the M3 screws (20) supplied in the package.
2. Install the RICO HYBRID to the rifle and adjust its position so that it produces a clear image and is comfortable for the shooter.
3. When the location is suitable, remove the M3 screws one at a time and apply a small amount of blue Locktite 242 to the threads.
4. Reinsert each screw and tighten to 20 in/lbs.
5. Allow the threadlocker to dry.

NOTE: Please note, torque is inch-pounds, NOT foot-pounds. If you do not have a torque wrench, apply until snug. Do not overtighten.

When the threadlocker is dry, install the mount and rifle scope to the Picatinny rail of your rifle.

1. Open both throw levers. Press the locking button (21) and pull the locking lever (22) to open.
2. Install the mount to the Picatinny rail.

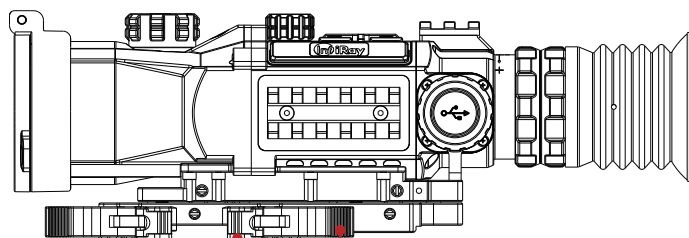

Locking Button (21) Locking Lever (22)

3. Press the levers closed to lock the mount in place. You will hear the lever and locking button click.

The RICO HYBRID is now ready to be zeroed. See Zeroing the RICO HYBRID on page 22 for instructions.

Adjusting the Throw Lever Tension

If necessary, you may loosen or tighten the tension of the throw levers by adjusting the nuts (23).

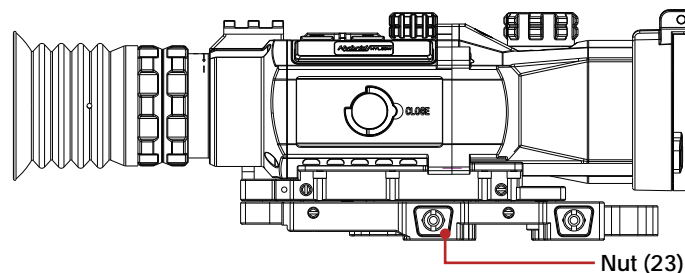

1. Open the throw levers. This will cause the adjustment nuts (23) to protrude on the opposite side of the mount.
2. Use the prong-side of the included spanner tool to turn the adjustment nut clockwise to tighten, or counterclockwise to loosen, to achieve the correct amount of tension. You should not feel any tension on the locking lever when closing until it reaches a 45-degree angle.

14. OPERATING INSTRUCTIONS

WARNING!

Don't point the objective lens towards any intense energy sources, such as laser radiation or the sun. This may render the electronic components inoperative. The warranty does not cover damage caused by improper operation.

Shortcut Buttons

The RICO HYBRID is operated via four control buttons and a large metal tactile Rotary Encoder. The large, easy-to-find Rotary Encoder provides audible and tactile feedback when twisted or pressed. The control buttons and Rotary Encoder can be used to perform shortcut operations from the home screen, as well as in the menu and full-screen interfaces. See Description of Control Buttons and Shortcuts on page 6 for shortcut button details.



Power On / Starting



1. Open the objective lens cap (1).
2. Long press the Power  Button for 3 seconds to turn on the rifle scope. The InfiRay Outdoor logo will appear.

To determine the current battery charge, check the battery status  icon in the top status bar.

Powering Off / Stopping

To power off the RICO HYBRID:

1. Long press the Power  Button. The shutdown screen will open, showing a 3-second countdown.
2. Continue holding the Power  Button until the 3-second countdown completes.
3. "Data saving..." appears onscreen and the RICO HYBRID will shut down automatically after saving.

NOTE: Releasing the Power  Button at any time before the countdown reaches zero will stop the shutdown process and the rifle scope will enter standby mode. Short press the Power  Button to exit standby.



WARNING: If using an external power supply, do not remove the power supply when saving data, otherwise the data may not be saved.

STANDBY MODE

Standby mode may be activated to conserve battery life.



Manually Enter Standby Mode

The user may enter standby mode manually at any time.

1. To enter standby from the home screen:
 - a. Long press the Power  Button to bring up the shutdown screen.
 - b. Release the Power  Button during the 3-second shutdown countdown to manually enter standby mode.
2. Short press the Power  Button to exit standby.

Set the RICO HYBRID to Enter Standby Mode Automatically

The rifle scope may be set to automatically enter standby mode after a specified length of inactivity.

1. In the main menu, select the standby  time, 5, 10, 20, 30, or 60 minutes. Once set, the RICO HYBRID will automatically enter standby according to the set time.
2. Short press the Power  Button to exit standby.

NOTES:

- When 5min, 10min, 20min, 30min, or 60min is selected:
 - The RICO HYBRID will enter standby mode automatically when it is tilted up or down at an angle of more than 70° or left or right at an angle of more than 30°.

- The RICO HYBRID will not enter standby mode while it is in a level firing position.
- When **off** is selected, standby mode is turned off and the rifle scope will operate until the battery runs out.
- See **Main Menu > Standby** on page 34 for instructions.

Adjusting the Focus

ADJUSTING THE DIOPTER/EYEPIECE

1. Rotate the eyepiece diopter adjustment ring (8) at the rear of the rifle scope right or left until the user interface onscreen is clear.
2. Look closely to ensure all screen symbols, the status bar, and the reticle appear sharp and in focus. No additional diopter adjustments are required unless the user wishes to make changes.

NOTES:

- After the initial adjustment, there is no need to rotate the eyepiece adjustment ring (8) for long distances or other conditions.
- If necessary during standard use, the objective lens focus knob (2) may be rotated to adjust fine focus on the target object being observed. See **Focusing the Objective Lens** below.

FOCUSING THE OBJECTIVE LENS

To adjust the focus on the target object:

1. Rotate the objective lens focus knob (2) left or right to adjust fine focus on the target object being observed.

NOTE: Re-adjusting the focus will be necessary if the distance to the target changes.

Activate / Deactivate the Reticle

The reticle is inactive when the RICO HYBRID is powered on for the first time. To activate the reticle, or to deactivate it at a later time:

1. From the home screen, long press the **Rotary Encoder** to enter the main menu.
2. Rotate the **Rotary Encoder** to move through the menu to select the settings menu item.
3. Short press the **Rotary Encoder** to enter the settings submenu.
4. Long press the **Rotary Encoder** and the **Brightness**  Button at the same time for 3 seconds to activate the reticle and hidden reticle and zeroing menu items.

Status Bar Overview

The status bars at the top, sides, and bottom of the screen show information on the operating status of the RICO HYBRID.

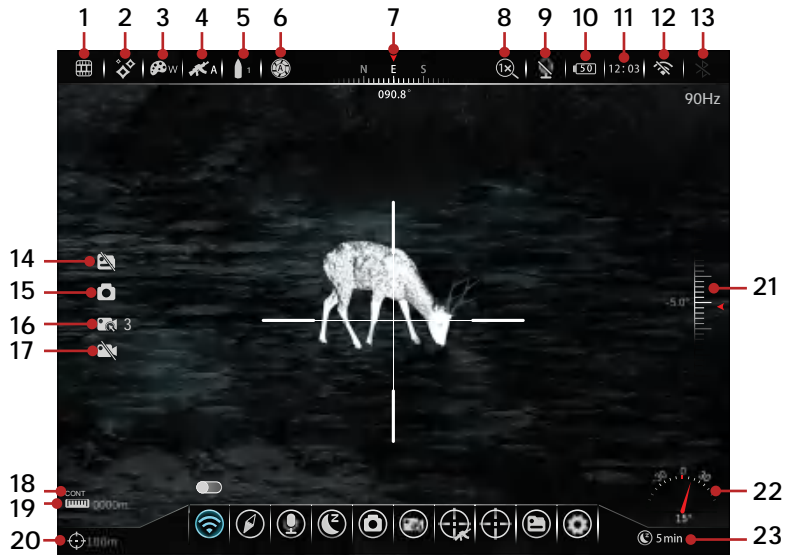

- 1 **Video Output:** Shows the video output status, on or off . Video output is off by default.
- 2 **Imaging Mode:** Shows the set imaging mode, clear , highlight , or fog .
- 3 **Color Palette:** Shows the set color palette, white hot , black hot , red hot , iron hot , rainbow , or outline.
- 4 **Zeroing Profile:** Shows the set zeroing profile, A, B, or C.
- 5 **Ballistics Profile:** Shows the set ballistics profile, 1, 2, or 3.
- 6 **Non-Uniformity Correction (NUC) Mode:** Shows the icon for the selected non-uniformity correction (NUC) mode, automatic , manual , or background . Automatic is selected by default. A countdown timer icon will appear when 5 seconds remain until an automatic NUC.
- 7 **Digital Compass:** The compass displays at the top of the screen when turned on. The compass is off by default.
- 8 **Digital Zoom:** Shows the set digital zoom level, 1x, 2x, 4x, or 8x.
- 9 **Microphone:** Shows the microphone status, on or off . Microphone is off by default.
- 10 **Battery:** Shows the current battery status, 1–100%. The battery status icon turns red when the battery is below 20%. When connected to an external power source, the battery status icon will alternate with the battery charging icon.
- 11 **Time:** Shows the current time in 24-hour format.
- 12 **Wi-Fi:** Shows the Wi-Fi status, on or off . Wi-Fi is off by default.











- 13 **Bluetooth:** Shows the Bluetooth status, on or off . Bluetooth is off by default.
- 14 **File Management Status:** The file management unavailable icon displays when Wi-Fi or recoil activated video is turned on in the main menu, when a video is recording, and when the rifle scope is connected to a computer via the data cable.
- 15 **Camera Icon:** Briefly appears when taking a photo.
- 16 **Recoil Activated Video Status:** Shows the recoil activated video status, on or off/unavailable . Recoil activated video is off by default. Recoil activated video is unavailable when a video recording is in progress.
- 17 **Video Recording Status:** Shows the video recording status, on or unavailable . Video recording is unavailable when recoil activated video is on.
- 18 **Rangefinding Status:** Shows the selected rangefinding mode, CONT or SGL when using the laser rangefinder (optional/not included) is connected.
- 19 **Target Distance:** Shows the target distance calculated by the optional laser rangefinder. A target distance may be entered manually in the quick menu when the LRF is not connected.
- 20 **Zero Distance:** Shows the selected zero distance.
- 21 **Standby Status:** Shows the standby icon and the status, off, 5min, 10min, 20min, 30min, or 60min. Standby is off by default.
- 22 **Tilt Angle:** The tilt angle displays when the digital compass is turned on. The compass is off by default.
- 23 **Pitch Angle:** The pitch angle displays when the digital compass is turned on. The compass is off by default.

Using the Quick Menu

In the quick menu, image brightness, contrast, and sharpness, NUC mode, target distance, reticle type and color, and zero distance, and Frame rate switching may be quickly adjusted.



In the quick menu:





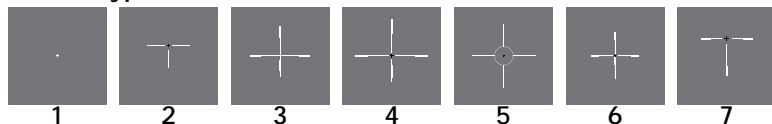



- Menu icons turn blue to indicate the current cursor position in the top-level menu and all submenus.
- Use the Rotary Encoder to navigate the quick menu:
 - Rotate to move left and right through the top-level menu or submenu options.
 - Short press to enter the submenu. Short press again to confirm submenu changes and return to the previous menu.
 - Long press to save any changes and exit to the home screen.
- Short press the Power  Button to return to the previous menu without saving.
- When the cursor is in the top-level menu, the system will exit to the home screen, after 5 seconds of inactivity. The system does not time out when the cursor is in a submenu.
- Upon exiting the main menu, the cursor location is stored for a single working session (until the RICO HYBRID is turned off). After restarting the RICO HYBRID and entering the menu, the cursor position will be at the first menu item.
- The eight quick menu options are:
 -  (Image Brightness): Choose from levels 0–9.
 -  (Image Contrast): Choose from levels 0–9.
 -  (Image Sharpness): Choose from levels 0–9.
 -  (Non-uniformity Correction Mode): Set the NUC mode to automatic (a), manual (m), or background (b).
 -  (Target Distance): Manually enter a target distance. Short press the Rotary Encoder to move between digits and rotate it to adjust the value of the selected digit.
 -  (Reticle Type): Choose from type 1–7 (see Reticle Types below) or the DIY reticle. Please note, the BDC reticle overrides the Reticle Type selection.
 -  (Reticle Color): Choose from white, black, red, green, or blue.
 -  (Zero Distance): Select a zero distance within the currently selected zeroing profile. Only the zero distances in the selected profile will be available for selection. The selected zero distance appears in the lower-left corner of the screen.
 -  (Frame rate switching): Short press the Rotary Encoder to move between Frame Rate(50Hz/90Hz) and rotate it to adjust the value of the selected digit.

Reticle Types



CLIP-ON MODE QUICK MENU

Clip-on mode has abbreviated menu options. The clip-on quick menu combines elements from the standard quick menu and main menu. Navigation of the clip-on mode quick menu is the same as described in the previous section; only the menu options are different:

-  (Bluetooth): Turn Bluetooth on or off.
-  (Image Contrast): Choose from levels 0–9.
-  (Image Sharpness): Choose from levels 0–9.
-  (Non-uniformity Correction Mode): Set the NUC mode to automatic (a), manual (m), or background (b).
-  (Microphone): Turn the microphone on or off.
-  (Status Bar): Turn status bar auto-hiding on or off.
-  (Units): Set the units of measure to meters or yards.
-  (Frame rate switching): Select 50Hz/90Hz frame rate.

Navigating the Main Menu

From the home screen, long press the Rotary Encoder to enter the main menu.





In all menu interfaces:

- Menu icons turn blue to indicate the current cursor position in the top-level menu and all submenus.
- Use the Rotary Encoder to navigate the menu:
 - Rotate to move left and right through the top-level menu and submenu options, and to turn on or off toggle switches.
 - Short press to enter the submenu. Short press again to confirm submenu changes and return to the previous menu.
 - Long press to save any changes and exit to the home screen.
- Short press the Power  Button to return to the previous menu without saving.

- When the cursor is in the top-level menu, the system will exit to the home screen, after 5 seconds of inactivity. The system does not time out when the cursor is in a submenu.
- Upon exiting the main menu, the cursor location is stored for a single working session (until the RICO HYBRID is turned off). After restarting the RICO HYBRID and entering the menu, the cursor position will be at the first menu item.

15. ZEROING THE RICO HYBRID

RICO HYBRID features a “freeze” zeroing method. To zero the RICO HYBRID:

1. Set a suitable target at the desired zero distance.
2. Confirm that the rifle is empty, safe, and pointed in a safe direction, with no ammunition near the weapon.
3. Adjust the image and device settings following the steps in the Quick Start Guide on page 8, if you have not done so already.
4. Select the zeroing profile, A, B, or C. See Rifle Profiles Menu > Zeroing Profile on page 36.
5. Select the ballistics profile, 1, 2, or 3. See Rifle Profiles > Ballistics Profile on page 37.
6. Based on the distance to the target you wish to zero, select a preset zero distance OR customize one of the preset zero distances to match. The RICO HYBRID supports custom zeroing distances of 1 to 999 meters or 1 to 999 yards. See Zeroing Menu > Zero Distance on page 39.
7. Ensure a stable platform and natural shooting position is achieved behind the rifle.
8. Load ammunition, aim, and take one good shot at the target.
9. Make your rifle safe and observe the location of impact on the target.
10. If the point of impact does not match the point of aim (the center of the reticle), adjust the X/Y position of the reticle. See Zeroing Menu > Reticle Zeroing on page 40.
11. In the submenu for the selected zero distance, center the reticle on the aiming point and long press the **Brightness**  and **Photo**  Buttons at the same time to freeze the image. The image freeze  icon will appear below the X/Y coordinates.
12. Rotate the Rotary Encoder to move between X and Y. Blue text indicates the cursor location.
13. Short press the Rotary Encoder to select the axis (X or Y) along which to move the reticle. A blue arrow appears to the left of the selected axis.
14. Adjust the X/Y position of the reticle until the reticle matches the point of impact.



- a. Rotate the Rotary Encoder clockwise to move in the positive direction: X= Right and Y= Up.
- b. Rotate the Rotary Encoder counterclockwise to move in the negative direction: X= Left and Y= Down.
- c. Upon moving the reticle, a white dot appears onscreen, indicating the original reticle position for the selected axis.

15. Short press the Rotary Encoder to save and deselect the axis.
16. Repeat steps 12–15 above to move the cursor along the second axis.
17. Long press the Rotary Encoder to save and exit.
18. Take a confirmation shot—the point of impact should now match the point of aim. If not, adjust the X/Y position of the reticle again.

For detailed Zeroing instructions, please see Zeroing Menu > Reticle Zeroing on page 40.

16. NON-UNIFORMITY CORRECTION

A non-uniformity correction (NUC) allows a thermal imager’s sensors to correct its pixels and eliminate image defects caused by pixel drift. A NUC will be performed automatically each time the RICO HYBRID is powered on.

The RICO HYBRID has three NUC modes, automatic , manual , and background . The selected NUC mode appears on the left side of the status bar. For instructions on setting the NUC mode in the quick menu, see Using the Quick Menu on page 19.

Automatic Mode

In automatic mode (A), the RICO HYBRID will perform a NUC automatically according to the internal software algorithm. There is no need to close the objective lens cap (1) as the HYBRID’s internal shutter covers the sensor.

A countdown timer will appear in the status bar when 5 seconds remain until an automatic NUC is performed. Pressing the Power  Button during the 5-second countdown will interrupt a pending NUC for approximately 5 minutes. The timer will appear only after the microbolometer temperature has stabilized—after approximately 10 minutes of continuous operation of the RICO HYBRID.

NOTE: A manual NUC (see below) may be performed at any time while in Automatic (A) mode.

Manual Mode

In manual mode (M), the user independently determines the need to perform a NUC based on the quality of the observed image. It is not necessary to close the objective lens cap (1) during a manual NUC, as the internal shutter covers the sensor.

To perform a manual NUC while in manual mode (or automatic mode):

1. From the home screen, short press the Power  Button.
2. A manual NUC is performed instantly.

Background Mode

In background mode (B), the user independently determines the need to perform a background NUC based on the quality of the observed image. A background NUC uses less power than an automatic or manual NUC because it does not use the internal shutter to cover the sensor; instead, the user must close the lens cap (1).

To perform a background NUC while in background mode:

1. Close the objective lens cap (1).
2. From the home screen, short press the Power  Button.
3. A prompt to close the lens cap (1) appears onscreen and the background NUC will be performed.

NOTE: If the lens is not properly covered, a temporary “image burn” will remain in the image until the next non-uniformity correction. This “image burn” is temporary and is not a defect or sign of permanent damage.



17. PHOTOGRAPHY AND VIDEO RECORDING

The RICO HYBRID is equipped with video recording and image capture. All videos and photos are automatically saved to the built-in 64 GB memory storage.

NOTE: Photo and video files are named with the time and date; therefore, it is recommended to set the date and time before using the photo and video functions. See **Settings Menu > Date and Time** on page 45. Alternatively, the date and time may be synchronized in the InfiRay Outdoor App.

Photography





To take a photo:

1. From the home screen, short press the Photo  Button.
2. The camera  icon will appear on the left side of the screen to indicate a photo was taken.





Video Recording

To record video:

1. Turn on the microphone in the main menu if desired. See **Main Menu > Microphone** on page 34.
2. From the home screen, long press the Photo  Button to start a video recording.
3. When the video recording starts, the video  icon and the recording timer, in HH:MM:SS (hour, minute, second) format, appear on the left side of the screen.
4. When recording, short press the Photo  Button to take a photo.
5. Long press the Photo  Button to stop and save the video recording.





NOTE: When recording video, file management and recoil activated video are unavailable and notification   icons appear above the video icon and timer.

Recoil Activated Video Recording

When recoil activated video is turned on in the main menu, a video is automatically recorded when a shot is taken. The RICO HYBRID will record 30 seconds before the shot and 30 seconds after the shot. The recoil activated video  icon and a 30-second timer will appear on the left side of the screen. See **Main Menu > Recoil Activated Video** on page 35 for instructions.



NOTES:

- When multiple shots are taken within the same 30-second period, only one video will be taken.
- When recoil activated video recording is turned on, file management and standard video recording are unavailable and notification icons appear above  and below  the recoil activated video icon and timer.

Video and Photography Notes

- You may enter and navigate the menu as normal during video recording. The user interface (the status bar, icons, and menu) is not captured in recorded video or photo files.
- Recorded photos are saved to the internal memory card.
 - Photos are saved in IMG_YYYYMMDDhhmmss_XX.jpg format.
 - Videos are saved in VID_YYYYMMDDhhmmss_XX.mp4 format.
 - YYYYMMDDhhmmss is year, month, day, hour, minute, and second.
 - XX is a 2-digit counter number.
 - The counter number cannot be reset.
 - If a file is deleted from the internal memory, its counter number is not taken by another file.
- The maximum duration of a recorded video file is 5 minutes. After this time, video recording will begin a new file automatically.
- The number of recorded files is limited only by the capacity of the internal memory. The internal memory can store up to 1,800 photos, 600 videos, and 370 recoil activated videos.
- The oldest photos or videos are automatically replaced when memory storage reaches capacity.
- Regularly check the available memory storage space and transfer video footage and images to other storage media to free up memory space, as needed, in the file management interface. See Main Menu > File Management on page 42.

18. ACCESSING THE INTERNAL MEMORY

When the RICO HYBRID is turned on and connected to a computer via the included data cable, it is recognized by the computer as a flash memory (USB) drive. This allows the user to access the saved multimedia files and copy or delete any desired files.

To access the internal memory:

1. Turn on the RICO HYBRID.
2. Plug the USB-C end of the data cable (19) into the USB-C port (11).
3. Plug the larger USB end of the data cable into your computer.
4. Double-click My Computer on your computer desktop.
5. Double-click to open the device named HYBRID_HYL5 to access the built-in memory.
 - a. The folder contains three multimedia subfolders, VIDEO-CIF, PHOTO-CIF, and RAV-CIF. The RAV-CIF folder contains the recoil activated videos.

- b. Recorded photos and videos are separated into subfolders by date.

6. Select the desired files or folders to copy or delete.

NOTES:

- Check available space in the internal memory storage in the RICO HYBRID's file management interface. See Main Menu > File Management on page 42. The memory storage availability listed when connected to a computer does not represent the actual memory availability, as the computer and device use different algorithms to calculate this value.
- The internal memory may be reformatted in the settings menu. See Settings Menu > Memory Card Reformatting on page 50. Do not use a formatting application or tool to format the internal storage.

19. USING THE INFIRAY OUTDOOR APP

The RICO HYBRID can be operated using the InfiRay Outdoor App when the rifle scope is connected to a smartphone or tablet via Wi-Fi.

1. Download the App for free and install it on your smartphone or tablet:
 - a. Scan one of the QR codes above to download the InfiRay Outdoor App from the App Store or Google Play; OR
 - b. Download the App from any app store.
2. Connect the RICO HYBRID to Wi-Fi:
 - a. In the main menu, turn on Wi-Fi. See Main Menu > Wi-Fi on page 33 for detailed instructions.
 - b. Open the App and press the ViewFinder  icon on the home screen.
 - c. Click the Connect Device WiFi button.
 - d. On the mobile device, go to Settings > Wi-Fi.
 - e. Select the RICO HYBRID from the list of Wi-Fi networks. It will appear in the list as "HYBRID_HYL50W-XXXX," where XXXX is the four-digit device serial number.
 - f. Enter the Wi-Fi password and tap the Join button. The default password is 12345678.
3. Operate the RICO HYBRID via the App:
 - a. Take real-time photos and videos, with or without audio.



- b. View, share, download, and delete photos and videos taken via the App, which are saved to the mobile device.
- c. Change the Wi-Fi password and SSID.
- d. Synchronize the date and time from the mobile device.
- e. Update the RICO HYBRID firmware.

NOTE: When a factory reset is performed, the Wi-Fi SSID and password are reset to the defaults, HYBRID_HYH50W-XXXX and 12345678. See Settings Menu > Factory Reset on page 50.

20. DIGITAL ZOOM

The RICO HYBRID will quickly increase the base magnification by enlarging the image from 1 to 8 times digitally.



To use digital zoom:

1. From the home screen, rotate the Rotary Encoder clockwise to zoom in or counterclockwise to zoom out on the observed object. The selected digital zoom level 1×, 2×, 4×, or 8× appears on the right side of the status bar.
2. The following table lists the real-time amplification corresponding to the digital zoom level:

BASE MAGNIFICATION	DIGITAL ZOOM MAGNIFICATIONS			
	1×	2×	4×	8×
2.5×	2.5	5	10	20

21. PICTURE IN PICTURE (PIP)

The Picture in Picture (PIP) function opens a small floating window with a magnified image view at the top of the screen.

1. From the home screen, long press the **Brightness**  Button. A 2× zoomed image, centered on the reticle, will appear at the top of the screen. Please note that the PIP image is 2× that of the digital zoom level shown in the status bar.
2. To exit PIP mode, long press the **Brightness**  Button.







NOTES: When the image in the main body of the screen is enlarged via digital zoom, the PIP image will enlarge accordingly.

22. REGION OF INTEREST (ROI)

The RICO HYBRID has a Region of Interest (ROI) feature which tells the thermal detector to focus on the center of the observed image.



1. From the home screen, short press the **Photo**  and **Brightness**  Buttons at the same time to turn on or off the ROI feature. A circular high-contrast, high-brightness region will appear in the center of the screen.
2. Short press the **Photo**  and **Brightness**  Buttons to turn off ROI.

23. CLIP-ON MODE

By default, the RICO HYBRID is set to standalone mode for use as a dedicated thermal sight. In clip-on mode, the RICO HYBRID is compatible with day optics up to 10× as an inline clip-on sight. In clip-on mode, the screen size is reduced to be in unity (1×).

To enable or disable clip-on mode:

1. From the home screen, long press the Rotary Encoder and the **Photo**  Button at the same time.



NOTES:

- We recommend going no higher than 10× on any rifle scope used in clip-on mode as image performance will become unsatisfactory.
- In clip-on mode, the X/Y position of the screen may be adjusted so that the center of the screen matches up with the day scope reticle. See the next section.
- Clip-on mode has no main menu and has a unique quick menu. See Clip-on Mode Quick Menu on page 21.

24. ADJUSTING CLIP-ON MODE SCREEN POSITION

In clip-on mode, the display size is reduced to be in unity (1×). On your first use, it may be necessary to adjust the X/Y of the screen to collimate the RICO HYBRID to your reticle. If your POI and POA differ in clip-on mode, adjust the screen as you would adjust the reticle in the zeroing section.

To adjust the screen position:



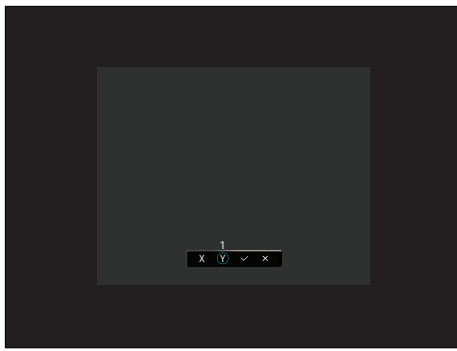

1. On the home screen with clip-on mode enabled, long press the Photo  and Brightness  Buttons at the same time to enter the clip-on mode screen position adjustment interface.
2. The screen-position adjustment interface has the following features:
 - 1 X: Move the screen along the X-Axis.
 - 2 Y: Move the screen along the Y-Axis.
 - 3 ✓: Save and return to the home screen.
 - 4 ✕: Exit the interface without saving.
3. To use the interface:
 - a. Rotate the Rotary Encoder to move through the interface. The cursor position is indicated by a white outline around the button.
 - b. Short press Rotary Encoder to select or deselect a button. Button selection is indicated by a blue outline around the button.
 - c. With X or Y selected, rotate the Rotary Encoder to move the X/Y position of the screen.
4. Adjust the X/Y position of the screen.
 - a. Rotate the Rotary Encoder clockwise to move in the positive direction: X= Right and Y= Up.
 - b. Rotate the Rotary Encoder counterclockwise to move in the negative direction: X= Left and Y= Down.
 - c. Rotate one click to move the reticle in the corresponding direction by 1 pixel. One full rotation (20 clicks) is equivalent to 20 pixels.
5. Select the ✓ Button to save the screen position and return to the home screen; **OR**
6. Select the ✕ Button to exit without saving and return to the home screen.



25. BDC RETICLE

The HYBRID's ballistics table and ballistics calculation function allow users to input ballistic information that matches their personal rifle and ammunition to create a custom BDC-style reticle. The HYBRID will reference input data to provide real-time correction based on a target distance input by the user or provided by the optional LRF module.

To set up the ballistics table:



1. Long press the Rotary Encoder to enter the main menu.
2. Rotate the Rotary Encoder to move to rifle profiles , and short press the Rotary Encoder to enter the submenu.
3. Rotate the Rotary Encoder to move to the zeroing profile , and short press the Rotary Encoder to enter the submenu.
4. Rotate the Rotary Encoder to move through the options, A, B, and C, and short press the Rotary Encoder to select the gun type and exit the submenu.
5. Select ballistics profile  to enter the submenu.
6. Select the bullet type, 1, 2, or 3, and exit the submenu.
7. Select ballistics table  to enter the submenu.
8. Select one of the three shooting table options, 500m, 1000m, or 2000m to edit it.
9. Use the Rotary Encoder to customize the shooting table. Rotate to move through the range inputs in the table, short press to add data to a table cell, and long press to save the data point and exit the cell.



NOTE: It is not necessary to input data for each distance point, but more information will result in greater accuracy.



10. Long press the Rotary Encoder to save the changes made to your selected ballistics table and exit the submenu.

To activate the BDC reticle:

11. In the rifle profiles , select BDC reticle  to enter the submenu.
12. Rotate the Rotary Encoder to turn on the toggle. When turned on, a BDC-style reticle based on your customized ballistics table is active and overrides the reticle set in the quick menu.
 - a. If you have already zeroed at the selected distance, the BDC reticle will reference that location as its zero position.

- b. If a yardage stadia is missing from this reticle, it is too close to the others and will only be visible when you zoom in by rotating the Rotary Encoder.

To enable the ballistic calculation function:

13. In the rifle profiles  menu, select ballistics calculator  to enter the submenu.
14. Rotate the Rotary Encoder to turn on the toggle. When the ballistic calculator is on, a secondary aiming point will be superimposed on the BDC reticle based on your customized ballistics table and the target distance.
 - a. The target distance is provided by the optional LRF module (see the documentation provided with the LRF for more information on its operation) or manually input in the quick menu (see Using the Quick Menu on page 19).

NOTES:

- A zeroing distance of 100m (109yd) must be selected in the zeroing  menu. See Main Menu > Zeroing on page 39.
- Ballistic data must be entered in the ballistics table in MOA. This data can be obtained from a ballistics solver or your ammunition maker.
- Ballistics data should be verified on a known range before using it in the field.
- If the drop in your ballistics table does not match the actual drop of your ammo/firearm, you can adjust, or true, the data in the table at any time based on your exact ballistics. This is normal and is not a result of a problem with the optic.

26. MAIN MENU OPTIONS AND DESCRIPTIONS

Menu and submenu options, from left to right are:



- Main Menu: Wi-Fi, Digital Compass, Microphone, Standby, Photo Mode, Recoil Activated Video, Rifle Profiles, Zeroing, File Management, Settings.
 - Rifle Profiles Menu: Zeroing Profile, Ballistics Profile, Ballistics Table, BDC Reticle, Ballistics Calculator.
 - Zeroing Menu: Choose from the 3 preset zero distances, Reticle Zeroing, and Custom Zero Distance.
 - Settings Menu: Video Output, Bluetooth, Status Bar, Date and Time, Compass Calibration, Pixel Defect Correction, Image Temperature, Units, Memory Card Reformatting, Factory Reset, and Info.

Menu option details, descriptions, and navigation instructions are listed in order on the following pages.

Wi-Fi

Turn Wi-Fi on / off

Turn on Wi-Fi to manipulate the RICO HYBRID via the InfiRay Outdoor App.

1. Long press the Rotary Encoder to enter the main menu.
2. Rotate the Rotary Encoder to select the Wi-Fi  menu item. Wi-Fi is selected by default when the menu is accessed for the first time.
3. Short press the Rotary Encoder to enter the submenu.
4. Rotate the Rotary Encoder to toggle Wi-Fi on / off. The Wi-Fi status, on  or off , changes in real-time and appears on the right side of the status bar.
5. Long press the Rotary Encoder to confirm the selection and return to the home screen.



Digital Compass



Turn the digital compass and gravity sensor on / off

1. Long press the Rotary Encoder to enter the main menu.
2. Rotate the Rotary Encoder to select the digital compass  menu item.
3. Short press the Rotary Encoder to enter the submenu.
4. Rotate the Rotary Encoder to toggle the digital compass and gravity sensor on / off. When turned on, the digital compass appears at the top of the screen, the pitch angle appears on the right side of the screen and the tilt angle appears in the lower-right corner.
5. Long press the Rotary Encoder to confirm the selection and return to the home screen.



Microphone

Turn the microphone on / off



1. Long press the Rotary Encoder to enter the main menu.
2. Rotate the Rotary Encoder to move through the menu to select the microphone  menu item.
3. Short press the Rotary Encoder to enter the submenu.
4. Rotate the Rotary Encoder to toggle the microphone on / off. The microphone status, on  or off , changes in real-time and appears on the right side of the status bar.
5. Long press the Rotary Encoder to confirm the selection and return to the home screen.



Standby

Set standby time

To conserve battery, the RICO HYBRID may be set to automatically enter standby mode after a specified length of inactivity.

1. Long press the Rotary Encoder to enter the main menu.
2. Rotate the Rotary Encoder to move through the menu to select the standby  menu item.
3. Short press the Rotary Encoder to enter the submenu.
4. Rotate the Rotary Encoder to move through the standby submenu options, 5min, 10min, 20min, 30min, 60min, or off. The standby status changes in real-time, and the standby  icon and status (5min, 10min, 20min, 30min, or 60min, or off) appear in the lower-right corner of the screen.
5. Long press the Rotary Encoder to confirm the selection and return to the home screen.
6. When standby is turned on, the RICO HYBRID will automatically enter standby mode after the set number of minutes of inactivity.
7. When in automatic standby mode, short press the Power  Button to exit standby and return to the home screen.







STANDBY NOTES:

- When 5min, 10min, 20min, 30min, or 60min is selected:
 - The RICO HYBRID will enter standby mode automatically when it is tilted up or down at an angle of more than 70° or left or right at an angle of more than 30°.
 - The RICO HYBRID will not enter standby mode while it is in a level firing position.
- When **off** is selected, standby mode is turned off and the rifle scope will operate until the battery runs out.
- Standby mode may be manually activated from the home screen at any time. See Standby Mode on page 16.

Photo Mode

Select the photo mode

The RICO HYBRID has three photo modes, single-shot, burst, and self-timer. Self-timer mode will automatically take a photo after a 5-second delay. Burst mode will take a photo every second for 6 seconds.

1. Long press the Rotary Encoder to enter the main menu.
2. Rotate the Rotary Encoder to move through the menu to select the photo mode  menu item.
3. Short press the Rotary Encoder to enter the submenu.
4. Rotate the Rotary Encoder to move through the submenu options, single-shot , burst , and self-timer  modes. Single shot mode is selected by default.
5. Long press the Rotary Encoder to confirm the selection and return to the home screen.



Recoil Activated Video

Turn the recoil activated video on / off

1. Long press the Rotary Encoder to enter the main menu.
2. Rotate the Rotary Encoder to move through the menu to select the recoil activated video  menu item.



3. Short press the Rotary Encoder to enter the submenu.
4. Rotate the Rotary Encoder to toggle recoil activated video on / off. The recoil activated video icon  appears on the left side of the screen when turned on and a 30-second timer starts. When turned on, the rifle scope will record 30 seconds of video before a shot is taken and 30 seconds after.
5. Long press the Rotary Encoder to confirm the selection and return to the home screen.

Rifle Profiles

Adjust the zeroing and ballistic settings



In the rifle profiles menu, you can set the zeroing profile, ballistics profile, view the ballistics table, and turn on or off the BDC reticle and the ballistics calculator.

1. Long press the Rotary Encoder to enter the main menu.
2. Rotate the Rotary Encoder to move through the menu to select the rifle profiles  menu item.
3. Short press the Rotary Encoder to enter the submenu. There are five submenu items: zeroing profile, ballistics profile, ballistics table, BDC reticle, and ballistics calculator.

RIFLE PROFILES MENU > ZEROING PROFILE

SUBMENU

Set the zeroing profile



1. In the rifle profiles submenu, rotate the Rotary Encoder to select the zeroing profile  menu item.
2. Short press the Rotary Encoder to enter the zero profile submenu.
3. Rotate the Rotary Encoder to move through the zeroing profile options, A, B, and C. The selection changes in real-time, and the zeroing profile  icon and selected profile, A, B, or C, appear on the left side of the status bar.
4. Long press the Rotary Encoder to confirm the selection and return to the home screen.



RIFLE PROFILES MENU > BALLISTICS PROFILE

SUBMENU

Set the ballistics profile

1. In the rifle profiles submenu, rotate the Rotary Encoder to select the ballistics profile  menu item.
2. Short press the Rotary Encoder to enter the submenu.
3. Rotate the Rotary Encoder to move through the options, 1, 2, and 3. The selection changes in real-time, and the ballistics icon  and the selected profile, 1, 2, or 3, appear on the left side of the status bar.
4. Long press the Rotary Encoder to confirm the selection and return to the home screen.



RIFLE PROFILES MENU > BALLISTICS TABLE

SUBMENU

View the ballistics table

1. In the rifle profiles submenu, rotate the Rotary Encoder to select the ballistics table  menu item.
2. Short press the Rotary Encoder to open the ballistics table.
3. Long press the Rotary Encoder to close the table and return to the home screen.



RIFLE PROFILES MENU > BDC RETICLE SUBMENU

Turn the BDC reticle on / off

1. In the rifle profiles submenu, rotate the Rotary Encoder to select the BDC reticle  menu item.
2. Short press the Rotary Encoder to enter the submenu.



3. Rotate the **Rotary Encoder** to toggle the BDC reticle on / off. The BDC reticle is off by default.
4. When turned on, the BDC reticle is active and overrides the reticle set in the quick menu. If you have already zeroed at the selected distance, the BDC reticle will reference that location as its zero position.
5. Long press the **Rotary Encoder** to confirm the selection and return to the home screen.

RIFLE PROFILES MENU > BALLISTICS CALCULATOR SUBMENU

Turn on the ballistics calculator

1. In the rifle profiles submenu, rotate the **Rotary Encoder** to select the ballistics calculator  menu item.
2. Short press the **Rotary Encoder** to enter the submenu.
3. Rotate the **Rotary Encoder** to toggle the ballistics calculator on / off. The ballistics calculator is off by default.
4. When the ballistic calculator is on, a secondary aiming point will be superimposed on the BDC reticle based on your customized ballistics table and the target distance provided by the optional LRF module or manually input in the quick menu.
5. Long press the **Rotary Encoder** to confirm the selection and return to the home screen.



Zeroing

Select or customize a zero distance

In the zeroing menu, you can select a preset zero distance, customize a preset zero distance, and adjust the reticle position for the selected zero distance. The RICO HYBRID supports custom zero distances of 1 to 999 yards or 1 to 999 meters.



NOTE: Before selecting or customizing a zero distance, please select a zeroing profile (A, B, or C) and a ballistics profile (1, 2, or 3). See the Rifle Profiles section on page 36.

1. Long press the **Rotary Encoder** to enter the main menu.
2. Rotate the **Rotary Encoder** to move through the menu to select the zeroing  menu item.
3. Short press the **Rotary Encoder** to enter the submenu. Three zero distances are shown in the submenu.

ZEROING MENU > ZERO DISTANCE SUBMENU

Select or customize a preset zero distance





1. In the zero distance submenu, rotate the **Rotary Encoder** to select a zero distance option.
2. Short press the **Rotary Encoder** to enter the submenu for the selected zero distance.
3. In the submenu for the selected zero distance, you may:
 - a. Enter the reticle zeroing interface  to adjust the X/Y position of the reticle at the selected zero distance. See Reticle Zeroing on the next page.
 - b. Customize the selected preset zero distance as needed. See Zeroing Menu > Customize Zero Distance on page 41.

ZEROING MENU > ZERO DISTANCE SUBMENU > RETICLE ZEROING

Adjust the reticle position of the selected zero distance.

In the reticle zeroing interface, the X/Y position of the reticle may be adjusted to match the point of impact.



1. In the submenu for the selected zero distance, the reticle zeroing  menu item is selected by default. Short press the **Rotary Encoder** to select it and enter the reticle zeroing interface.
2. The reticle zeroing interface has the following features:
 - 1 **X:** Horizontal point of impact change (in cm or inches).
 - 2 **Y:** Vertical point of impact change (in cm or inches).
 - 3 **Freeze Icon:** Appears when the image is frozen.
 - 4 **Reticle:** Shows the new reticle position.
 - 5 **White Dot:** Indicates the original reticle position for the selected axis.
3. Center the reticle on the aiming point and long press the **Brightness**  and **Photo**  Buttons at the same time to freeze the image. The image freeze  icon will appear below the X/Y coordinates.
4. Rotate the **Rotary Encoder** to move between X and Y. Blue text indicates the cursor location.
5. Short press the **Rotary Encoder** to select the axis (X or Y) along which to move the reticle. A blue arrow appears to the left of the selected axis.
6. Adjust the X/Y position of the reticle until the reticle matches the point of impact.
 - a. X (horizontal) is the windage and Y (vertical) is the elevation.

NOTE: The red "X" indicates the point of impact. It is shown in the figure for illustration purposes and is not an interface element.

- b. Upon moving the reticle, a white dot appears onscreen, representing the original reticle position for the selected axis.
 - c. Rotate the **Rotary Encoder** clockwise to move in the positive direction: X= Right and Y= Up.
 - d. Rotate the **Rotary Encoder** counterclockwise to move in the negative direction: X= Left and Y= Down.
 - e. Rotate one click to move the reticle in the corresponding direction by 1 pixel. One full rotation (20 clicks) is equivalent to 20 pixels.
 - f. When adjusting your zero at a distance of 50 yards, one click will change the impact point by 0.25" and one full rotation moves 5" as shown in the X and Y coordinate displays. At 100 yards that same click moves 0.51". At 200 yards one click moves 1.02".
 - g. Changing your zero distance will change the distance of your X/Y adjustments automatically. If your selected zero distance has a correction of 2.04" at 100 yards, it will automatically change to 4.08" if you change the zero distance to 200 yards.
7. Save **OR** clear the reticle position along the selected axis.
 - a. Short press the **Power**  Button to clear the reticle position for the selected axis, returning the reticle to the original position for that axis; **OR**
 - b. Short press the **Rotary Encoder** to save the position for the selected axis and deselect it. The blue arrow will disappear.
 8. Repeat steps 4–7 to move the reticle to the desired location.
 9. Long press the **Rotary Encoder** to save and return to the home screen.
 10. Take a confirmation shot—the point of impact should now match the point of aim. If not, adjust the X/Y position of the reticle again.

ZEROING MENU > ZERO DISTANCE SUBMENU > CUSTOMIZE ZERO DISTANCE

Customize a preset zero distance

The RICO HYBRID supports custom zero distances of 1 to 999 yards or 1 to 999 meters.

1. In the submenu for the selected zero distance, rotate the **Rotary Encoder** to move to the preset zero distance.







2. Short press the **Rotary Encoder** to begin customizing the zero distance. A blue arrow icon will appear above the selected digit to mark the cursor location. The far-left digit is selected by default.
3. Rotate the **Rotary Encoder** to increase or decrease the value of the selected digit, from 0–9.
4. Short press the **Rotary Encoder** to switch between the three digits. The blue arrow icon will move to indicate the selected digit.
5. Long press the **Rotary Encoder** to save the custom zero distance and return to the zero distance submenu.
6. The new zeroing distance appears in the lower-left corner of the screen.





File Management



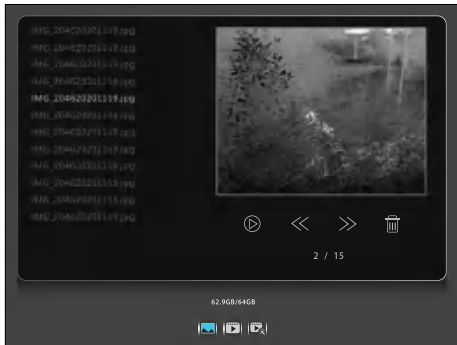





Manage photo and video files

NOTE: The file management menu item is disabled when Wi-Fi or recoil activated video is turned on in the menu, when a video is recording, and when the rifle scope is connected to a computer via the data cable.

1. Long press the **Rotary Encoder** to enter the main menu.
2. Rotate the **Rotary Encoder** to move through the menu to select the file management  menu item.
3. Short press the **Rotary Encoder** to enter the file management interface.
4. The file management screen has the following features:
 - 1 **Memory:** Shows used memory and total memory in GB. .
 - 2 **Operations Menu:**
 - a. : Manage photo files.
 - b. : Manage video files.
 - c. : Manage recoil activated video files.



- 3 **File List:** Lists the files for the selected multimedia type, photo, video, or recoil activated video. The selected photo or video is indicated by a blue box around the file name.
- 4 **Thumbnail Window:** Shows a thumbnail of the selected photo, video, or recoil activated video.
- 5 **File Management Menu:**
 - a. : View/play the selected file.
 - b. : Go to the previous page of files.
 - c. : Go to the next page of files.
 - d. : Delete the selected file.
 - e. **Page Count:** Shows current page number and total number of pages.

5. Rotate the **Rotary Encoder** to move through the operations menu options and short press the **Rotary Encoder** to select photo , video , or recoil activated video .
6. Rotate the **Rotary Encoder** to move through the file list.
7. Short press the **Rotary Encoder** to select a file. A blue box will appear around the file name and the selected photo or video will appear in the thumbnail window.
8. Rotate the **Rotary Encoder** to move through the file management menu options.
9. Short press the **Rotary Encoder** to select a file option:
 - a. Select  to view the selected file full-screen. If viewing a video file, short press the **Rotary Encoder** a second time to play the video, and short press a third time to pause.
 - b. Select  to view the next page.
 - c. Select  to the previous page.
 - d. Select  to delete the file.
10. Short press the **Power**  Button to return to the previous level of the file management interface.
11. When returned to the Operations Menu, short press the **Power**  Button to exit the interface and return to the previous menu.

Settings

Adjust advanced settings

1. Long press the **Rotary Encoder** to enter the main menu.
2. Rotate the **Rotary Encoder** to move through the menu to select the settings  menu item.





3. Short press the **Rotary Encoder** to enter the submenu.
4. The submenu items are video output, Bluetooth, status bar, date and time, compass calibration, pixel defect correction, image temperature, units, memory card reformatting, factory reset, and info.

SETTINGS MENU > VIDEO OUTPUT

Turn video output on / off



The video output function enables connectivity with an external display or recording device via analog video.

1. In the settings submenu, rotate the **Rotary Encoder** to select the video output  menu item.
2. Short press the **Rotary Encoder** to enter the submenu.
3. Rotate the **Rotary Encoder** to toggle video output on / off. The video output status, on  or off , changes in real-time and appears on the right side of the status bar.
4. Long press the **Rotary Encoder** to confirm the selection and return to the home screen.



SETTINGS MENU > BLUETOOTH

Turn Bluetooth on / off

1. In the settings submenu, rotate the **Rotary Encoder** to select the Bluetooth  menu item.
2. Short press the **Rotary Encoder** to enter the submenu.
3. Rotate the **Rotary Encoder** to toggle Bluetooth on / off. The Bluetooth status, on  or off , changes in real-time and appears on the right side of the status bar.
4. Long press the **Rotary Encoder** to confirm the selection and return to the home screen.



SETTINGS MENU > STATUS BAR

Turn status bar auto-hiding on / off

This function enables automatic hiding of all interface information, aside from the reticle, for unobstructed image view.

When auto-hide is turned on, after 15 seconds of inactivity the status bar, digital compass, and all interface icons will be automatically hidden. Shortcut buttons and the menu are disabled until the entire interface is again displayed. Press any button to show all interface information again.



NOTE: When auto-hide is on and the main menu is open, the menu will hide after 15 seconds of inactivity and the rest of the user interface will hide after an additional 15 seconds.

1. In the settings submenu, rotate the **Rotary Encoder** to select the status bar  menu item.
2. Short press the **Rotary Encoder** to enter the submenu.
3. Rotate the **Rotary Encoder** to toggle status bar auto-hiding on / off. Status bar auto-hiding is off by default.
4. Long press the **Rotary Encoder** to confirm the selection and return to the home screen.

SETTINGS MENU > DATE AND TIME

Set the date and time

1. In the settings submenu, rotate the **Rotary Encoder** to select the date and time  menu item.
2. Short press the **Rotary Encoder** to open the date and time window.
3. The date/time window has the following features:
 - 1 **Date/Time Fields:** YYYY-MM-DD: Year-Month-Day
HH:MM: Hour:Minute
 - 2 **✓ Button:** Save and exit
 - 3 **✗ Button:** Close window without saving



To set the date and time:

1. The cursor position is indicated by a blue outline around the field or button. The year value is selected by default. The date and time are displayed in YYYY-MM-DD HH:MM format.
2. Rotate the **Rotary Encoder** to select the correct number for each date/time field, year, month, day, hour, and minute.
3. Short press the **Rotary Encoder** to move through the fields and buttons in the date/time window.
4. Long press the **Rotary Encoder** to save the date/time and return to the home screen; **OR**
5. Rotate the **Rotary Encoder** to move to the **✕ Button**. Short press the **Rotary Encoder** to select it and close the window without saving.

NOTES:

- Alternatively, the date/time may be synchronized with a mobile device using the InfiRay Outdoor App. See [Using the InfiRay Outdoor App](#) on page 27.
- The time displays on the right side of the status bar.

SETTINGS MENU > COMPASS CALIBRATION

Calibrate the digital compass

1. In the settings submenu, rotate the **Rotary Encoder** to select the compass calibration  menu item.
2. Short press the **Rotary Encoder** to begin compass calibration.
3. A triaxial coordinate icon prompt will appear on the screen.
4. Follow the icon prompt to rotate the RICO HYBRID at least 360 degrees along each axis, X, Y, and Z. Rotations must be completed within the 15-second calibration time.
5. After 15 seconds, the calibration is finished and the RICO HYBRID will automatically exit to the home screen.



SETTINGS MENU > PIXEL DEFECT CORRECTION

Select and correct defective pixels

Defective pixels are pixels that do not change correctly compared to the other image pixels—they are either brighter or darker than surrounding pixels. The RICO HYBRID has a tool that corrects defective pixels on the sensor using its internal software.



1. Long press the **Rotary Encoder** to enter the main menu.
2. Rotate the **Rotary Encoder** to move through the menu to select the pixel defect correction  menu item.
3. Short press the **Rotary Encoder** to enter the defective pixel correction interface.
4. The pixel correction interface has the following features:

- 1 **PIP Window:**
The Picture in Picture window appears in the lower-left corner.
- 2 **Pixel Cursor:**
Cursor appears in the center of the screen in place of the reticle. Move the cursor to the position of the defective pixel.
- 3 **X Button:** Move the cursor horizontally.
- 4 **Y Button:** Move the cursor vertically
- 5 **Add Button:** Add a defective pixel to the “to be corrected” list.
- 6 **CXL Button:** Clear pixels saved in the “to be corrected” list.
- 7 **✓ Button:** Save and exit.
- 8 **✕ Button:** Exit the interface without saving.

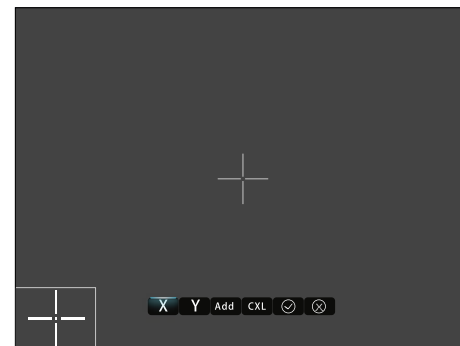

To select and correct defective pixels:

5. The button cursor position is indicated by a blue highlight at the top of the button. The cursor is located on the **X Button** by default.