

User Manual

PORTABLE CD PLAYER WITH CASSETTE RECORDER

CD-X2A

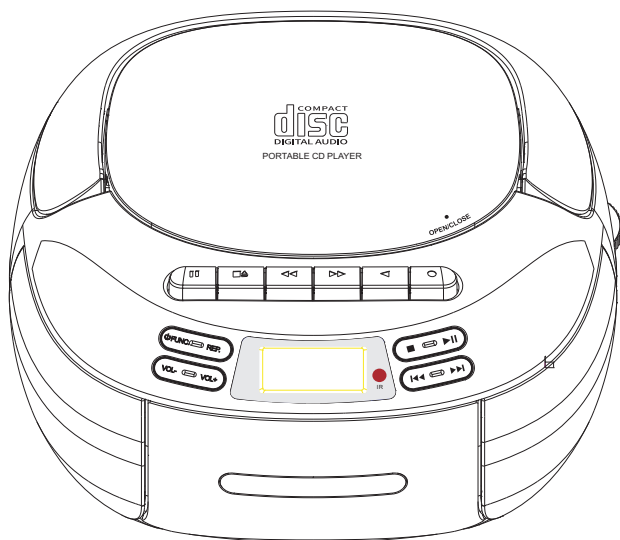

Thank you for purchasing our personal audio products. High-quality CD player is an electronic acoustic technology product carefully designed by our company. To obtain the perfect use effect and prolong the service life of this product, correct use and maintenance are very important, please read this manual carefully before use it.

CONTENTS

- VERY IMPORTANT TIPS
- FUNCTION DESCRIPTION
- REMOTE CONTROL DESCRIPTION
- POWER SUPPLY
- CD / MP3 DISC OPERATION
- USB OPERATION
- AUX OPERATION
- TAPE OPERATION
- BLUETOOTH OPERATION
- RADIO OPERATION
- SPECIFICATIONS
- SAFETY INSTRUCTIONS
- WARRANTY
- PACKING LIST

VERY IMPORTANT TIPS

▲ When using this product, please follow the prescribed steps, otherwise you may be exposed to harmful radiation. This CD player is a CLASS 1 LASER product.

▲ When the CD cover is opened or carelessly closed, an invisible laser will be generated.

▲ Please do not touch the bald head at will, otherwise it will affect the playback performance.

▲ The lightning flash with arrowhead symbol within an equilateral triangle is intended to alert the user to the presence of uninsulated “hazardous voltage” within product's enclosure, which may be sufficient to induce a risk of electric shock to persons.

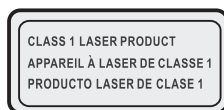

FUNCTION DESCRIPTION

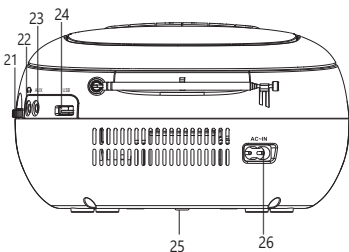
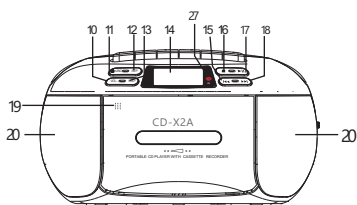
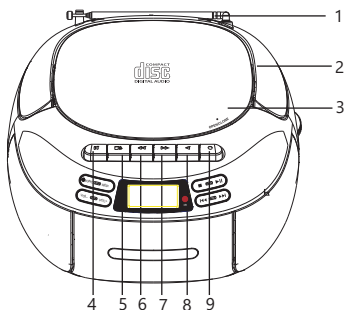

1. Antenna
2. Handle
3. CD Door Switch
4. Tape Pause Button
5. Tape Stop/Tape Door Open Button
6. Tape Fast Forward Button
7. Tape Fast Rewind Button
8. Tape Playback Button
9. Tape Record Button
10. Volume Decrease Button-
11. Power On/Off/Function Selector Button
12. Repeat Button
13. Volume Increase Button
14. LCD Display
15. Previous Song/Fast Rewind Button
16. Stop Button
17. Play/Pause Button
18. Next Song/Fast Forward Button
19. Tape Door Close
20. Speakers
21. Channel Tuning
22. Earphone Jack
23. Audio Input Interface
24. USB Socket
25. Battery Compartment
26. AC Outlet
27. Remote Control Receiving Point

REMOTE CONTROL DESCRIPTION

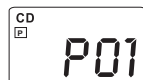
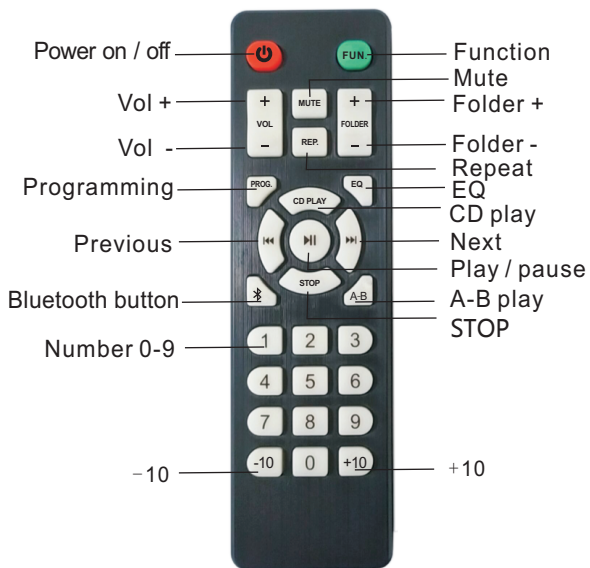

Figure 1



Figure 2

1. **Power on / off:** product on / off button.
2. **Vol + / -:** volume increase / decrease.
3. **Function:** in the power on status, press this function button to select different functions. The sequence is: CD Play-USB-Bluetooth-Radio-Aux Conversion.
4. **Mute:** product mute.
5. **Folder + / -:** select a folder to be played.
6. **Repeat:** repeat button to cycle through songs when playing USB flash disk/CD/MP3 discs.
7. **Programming:** press the STOP button on the remote control to stop the CD/MP3 discs/USB, then press this PROG. button to entry the programming interface (the LCD will flash and display "P01" on the screen, like above figure 1). Press the previous or

next song button to select the track to be programmed, and then press this PROG. button to confirm after programming. Press the play/pause button to play in the sequence of the programmed track(Screen will display like above figure 2). If you need to stop, just press the STOP button.

8.**EQ**: when the product is working, press EQ button to change different music effects, namely: FLA-CLA-ROC-POP-JAZ (Flat - Classical - Rock - Pop - Jazz)

9.**CD play**: press this button to go to the CD play function.

10.**Previous**: short press to the previous song, long press to fast rewind.

11.**Next**: short press to the next song, long press to fast forward.

12.**Play / pause**: song play and pause.

13.**Stop**: stop to play song.

14.**Bluetooth button**: press this button to go to Bluetooth mode.

15.**A-B play**: A-B repeat button .

16.**Number 0-9**: press the number button 0-9 to directly select the song number when playing USB flash disk / CD / MP3 disc.

17.**-10 / + 10**: step back with 10 tracks per click, and step forward with 10 tracks per click.

POWER SUPPLY

1. **Using Battery**: open the battery compartment door at the bottom, correctly install 6 (1.5V “C” Size) batteries according to the direction shown in the battery room, then cover the cell door.

2. **AC Power**: plug one end of the AC power cord into the AC power jack of this product, and plug the other end into the 110-120V household power outlet.



NOTE:This product can only use the AC power supply voltage indicated on the manual or the casing.

NOTE:

1. When unplugging the AC power cord, hold the plug by hand instead of pulling the power cord.
2. Never touch the AC power plug when your hands are wet, otherwise it may cause electric shock.
3. The power cord should be fixed to avoid twisting or trampling.
4. Do not use power sockets with too thin and extended wires. If the Outlet is overloaded, it will cause fire or electric shock.
5. If the product is not used for a long time, Please unplug the AC power plug from the socket and take out the dry battery to prevent the battery from leaking and damaging the parts.
6. As the product needs to consume power to monitor the remote control state, it is recommend to use AC supply to power the product in daily usage. Otherwise, it will run out the dry battery soon.

CD / MP3 DISC OPERATION

1. After power on, press the function selector button (**FUNC.**) to select CD / MP3 mode. LCD shown as "^{CD} Cd "
2. Press to open the CD compartment door, and place the disc printing surface upward on the spindle of the CD movement. Then close the CD compartment door, the song will be played automatically in a few seconds, and the LCD will display the serial number of your current song. The format of the disc, such as "CD", "MP3", etc.
3. Long press the Vol + button (**VOL+**) or Vol - button (**VOL-**) to adjust the volume appropriately.
4. Press the play / pause button (**▶||**) once to temporarily stop playing, and press this button again to resume playing.
5. If you need to stop playing halfway, press the stop button (**■**) to stop playing.

6. During playback, short press the previous/next button () to jump to the previous/next song; long press the previous/next button () to fast rewind or fast forward.

7.Repeat function:

- In the process of playing CD, press the repeat button () once, the current song you listen to will enter into single cycle, and displayed on the LCD as shown in figure 3;
- Press the repeat button twice, if your MP3 disc contains a file directory, it will repeat to play the current folder for you. Displayed on the LCD as shown in figure 4;
- Press the repeat button three times, the whole disc will be played repeatedly, and displayed on the LCD as shown in figure 5;
- Press the repeat button four times, the whole disc will be played randomly. Displayed on the LCD as shown in figure 6;
- Press the repeat button five times to resume normal playback.



Figure 3
Single Cycle









Figure 4
Current Folder Repeat





Figure 5
Whole Disc Repeat



Figure 6
Random Play

8.In the stop state (), press the repeat button () on the machine to program songs. Press previous/next button ( / ) to select the song you want to program, then press repeat button () to confirm after programming. Press the play/pause button () to play in the sequence of the programmed songs.

USB OPERATION

1.Insert the USB with MP3 format into the corresponding USB socket press the function switch button () on the unit or the remote control to switch to USB play mode(LCD shown as "  "), then

you can play song after the machine detects it.

2.USB playback operation method is the same as the section "CD/MP3 Disc Operation."







AUX OPERATION

1.Short press the function selector button (**FUNC.**), select the AUX function,then connect the external sound source to this machine with AUXcord, the song will be played after the machine detects it. (LCD shown as " **AUX** ")

2.The machine has the function of amplifying and outputting all external sound sources (such as mobile phone, MP3 player, tape Walkman, CD player, radio, etc.).

TAPE OPERATION

TAPE PLAY

1. Press the function selector button (**FUNC.**) to select the TAPE function. (LCD shown as " **TAPE** ") .
2. Press the tape stop / open button () to open the tape door, place the tape correctly and close the tape door.
3. Press the tape playback button () to play, and press Vol + button (**VOL+**) or Vol - button (**VOL-**) to adjust the volume appropriately.
4. Press the tape pause button () once to temporarily stop playing, and press the tape pause button () again to resume playing.
5. To fast forward or fast rewind the tape, just press the tape fast forward button () or the tape fast rewind button (), then press tape playback () button again to play
6. When the magnetic stripe in the tape reaches the end, the tape playback will stop automatically.

7. If you want to stop playback halfway and take out the tape, press the Tape Stop/Tape Door Open Button once to stop, and press twice to open the tape door.

TAPE RECORDING

1. This product has function of built-in microphone input tape. It can record sound under CD/USB/Bluetooth/AUX/Radio mode, Note: voice cannot be recorded.

2. Press to open the tape door and put in a tape on it. Then press to choose one of the CD/USB/Bluetooth/AUX/Radio mode you want to record. When it playing, press the tape playback button (◀) and tape record button (●) at the same time to start record.

3. Press the tape stop / open button (■▲) to stop record, then press the function selector button (FUNC.) to select the TAPE function. (LCD shown as "TAP").

4. Press the tape fast rewind button (▶▶) to back to the sound you record, then press the tape playback (◀) button to play.

BLUETOOTH OPERATION

1. Press the function selector button (FUNC.) to select "BT" mode (LCD shown as "bt"), at this time, Bluetooth works in pairing state.

2. Turn on the mobile phone or other Bluetooth device. When it searches for the local Bluetooth device, the Bluetooth name "CD-X2A" will be displayed. After successful pairing, you will hear a prompt tone.

3. When Bluetooth is playing, short press the play button to play / pause.

4. After Bluetooth pairing, long press the stop button to clear the Bluetooth connection function.

RADIO OPERATION

1. Press the function selector button (**FUNC.**) to enter the radio state. (LCD shown as "r Ad")
2. Press the **VOL+** / **VOL-** button to adjust it to the appropriate volume.
3. Turn the channel selection button to select your favorite stations. The LCD will display the corresponding radio frequency.
4. Pull out the antenna to get a good reception.

SPECIFICATIONS

Frequency range	FM: 87.5-108MHZ AM: 520-1720KHz
Bluetooth	Bluetooth 5.1
Power source	AC110/120V~60Hz DC 9V(1.5V x 6"C")
CD playback sound	31.5Hz-16kHz±3dB
Maximum power consumption	15w
Size	8.54x8.4*4.8in
Weight	3.3 lb (Not include batteries)

SAFETY INSTRUCTIONS

※Use Environment

1. Do not expose the machine to rain or damp places, and place and use the machine away from bathtubs, washing boxes, swimming pools, etc
2. Do not put any source of danger on the device (for example, objects filled with liquid, lighted candles).
3. Do not use the machine near heat sources, including radiator pipes, heaters or other appliances that generate heat.
4. Put the machine on a flat surface to use.
5. The machine should be placed in a location with sufficient ventilation

5. The machine should be placed in a location with sufficient ventilation space around it, and there should be 5-10 cm of space around the front and rear of the machine, so that the machine can have enough space for ventilation.

-Do not place the machine on a bed, blanket or similar surface to prevent the vents of the machine from being blocked, and do not cover the machine with tablecloths, paper, etc.

6. Be careful not to let solids or liquids enter the body from the radio.

7. Water vapor may condense on the laser lens under the following conditions:

-When the unit is moved from a cold place to a warm place;

-When the heating system has just opened;

-When the machine is used in a very humid room;

-When the unit is cooled by the air conditioning system.

When condensation occurs in the unit, the system cannot operate normally.

If this happens, you can temporarily stop using the unit for a few hours before operating it again.

8. The machine should not be exposed to water droplets or splashes, and objects filled with liquids such as vases should not be placed on the equipment.

Precautions

1. In the event of a thunderstorm and you will not use the machine for a long time, you should unplug the AC power plug from the socket or take out the battery to prevent battery fluid from leaking and damaging the machine.

2. Different types of batteries, old and new batteries cannot be mixed, and the batteries must not be charged or heated. When removing the exhausted battery, if the battery leaks, remove the battery and wipe the liquid thoroughly. Waste batteries should be placed in officially designated recycling locations to avoid environmental pollution.

3. When playing, the battery life is limited, please use AC power as much as possible.

4. When using a battery to supply power, the AC power cord must be removed from the unit. When the volume is reduced or the sound is distorted, please replace the battery.

5. The battery (battery pack or battery pack) should not be used in an overheated environment (such as direct sunlight, open flames or similar environments) .

✂ Maintenance

Please place the machine in a well-ventilated place, not in the sun or other places that generate high temperature and humidity. During maintenance, please use a soft cloth moistened with a thinner detergent to wipe the body. Do not use strong solvents such as alcohol, stupid or thinner.

WARRANTY

- This CD boombox has full 12-month warranty against manufacturing defects.
- The warranty period begins form the date of purchase.

PACKING LIST

CD Player	1
AC Power Cord	1
Remote Control	1
User Manual	1
AUX Cable	1



Made in china

FCC Caution: Any changes or modifications not expressly approved by the party responsible for compliance could void the user's authority to operate this equipment.

This device complies with Part 15 of the FCC Rules. Operation is subject to the following two conditions:

- (1) This device may not cause harmful interference, and
- (2) this device must accept any interference received, including interference that may cause undesired operation.

This equipment should be installed and operated with minimum distance 20cm between the radiator and your body.

NOTE:

This equipment has been tested and found to comply with the limits for a Class B digital device, pursuant to Part 15 of the FCC Rules.

These limits are designed to provide reasonable protection against harmful interference in a residential installation. This equipment generates, uses and can radiate radio frequency energy and, if not installed and used in accordance with the instructions, may cause harmful interference to radio communications.

However, there is no guarantee that interference will not occur in a particular installation. If this equipment does cause harmful interference to radio or television reception, which can be determined by turning the equipment off and on, the user is encouraged to try to correct the interference by one or more of the following measures:

- Reorient or relocate the receiving antenna.
- Increase the separation between the equipment and receiver.
- Connect the equipment into an outlet on a circuit different from that to which the receiver is connected.
- Consult the dealer or an experienced radio/TV technician for help.