

VIVITAR® WIRELESS CD RETRO BOOMBOX



CD Player

Cassette Player

AM/FM Radio



USER'S MANUAL: V60098BT



Important Safety Precautions

When using your Vivitar Wireless CD Retro Boombox, basic safety precautions should always be followed, including the following:

1. READ ALL INSTRUCTIONS BEFORE USING YOUR SPEAKER.
2. Do not use your speaker near water. Clean using a soft cloth or paper towel.
3. Do not place your speaker on any wet surfaces.
4. Do not allow children or the infirm to play with your speaker without adult supervision.
5. Do not expose your speaker to excessive heat, flames or fire.
6. Always press all buttons or switches carefully. Do not manhandle your speaker.
7. Do not use in extremely dry environments, as this can lead to static discharge during usage.
8. Do not expose your speaker to temperatures above 40°C. Keep out of direct sunlight.
9. Do not attempt to repair this product yourself. Contact a qualified service center if your speaker is in need of service.
10. Do not drop, puncture or expose your speaker to excessive trauma.
11. Your speaker is not intended for commercial use.
12. Do not place near objects that generate a strong magnetic field.
13. Do not touch the AC power adapter with wet hands or expose it to water.
14. Do not twist, step on or bash the AC adapter. This may damage the plug.
15. Unplug your speaker when not in use for long periods of time or during lightning storms.
16. Only use the AC adapter provided with this item. Do not connect any external AC adapters, doing so may cause the product to combust.

BATTERY WARNING:

- Do not mix old and new batteries.
- Do not mix alkaline, stand (carbon-zinc) or rechargeable (nickle-cadmium) batteries.
- Batteries are not to be inserted with the wrong polarity.
- Exhausted batteries are to be removed.
- The supply terminals are not to be short-circuited.

Please recycle or dispose of the battery properly. Contact local recycling facilities and/or the manufacturer of your battery for further information

Introduction

Thank you for purchasing your Vivitar Wireless CD Retro Boombox. You can use your speaker with most smartphones and Bluetooth devices to stream music. You can play cassette tapes or CDs. In order to get the best results, please read this manual first before using your speaker.

Package Contents

- Vivitar Wireless CD Retro Boombox
- AC power cable
- User's Manual with Warranty Information

Specifications

Bluetooth Specification: V5.1

AC Power: AC 120V

DC Power: DC9V (UM-2*6 pcs)

Power: 15W

Speaker Power Output: 3W

Supported Cassette Tape: 6 Keys

AUX-IN & Headphone Jack: 3.5mm

Supported Disc Format: CD/CD-R/CD-RW

Radio Frequency: FM: 87.5~108.5 MHz / AM: 520~1710KHz

A Quick Look at Your Device

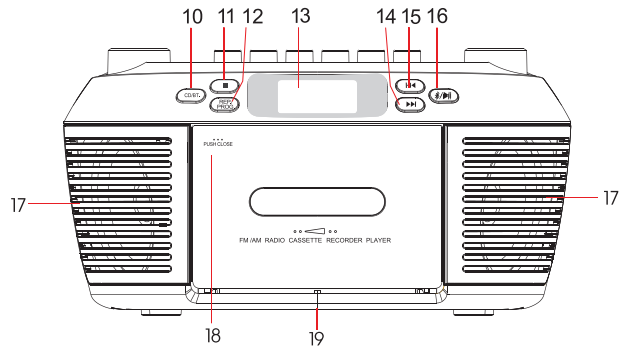
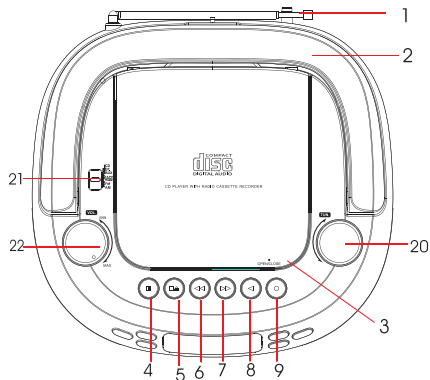

1. FM Antenna
2. Handle
3. CD Compartment Cover
4. Cassette Pause
5. Cassette Stop/Open
6. Cassette Fast Forward
7. Cassette Fast Rewind
8. Cassette Play
9. Cassette Recording
10. CD/Bluetooth
11. Stop
12. Repeat/Program
13. LCD Display
14. Next/Fast Forward
15. Previous/Fast Rewind
16. Play/Pause
17. Left/Right Speaker
18. Cassette Close
19. Battery Compartment (Bottom)
20. Tuning Knob
21. Mode Switch
22. Volume Knob
23. AUX-IN Jack
24. Headphone Jack
25. AC Port

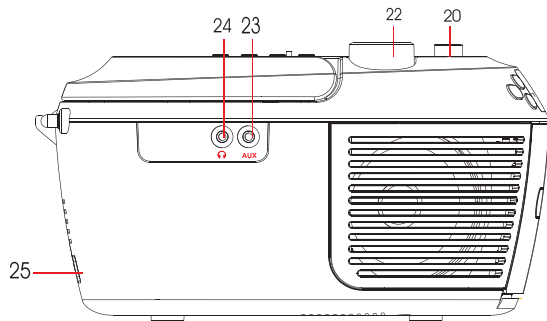

Powering Your Speaker

Inserting Batteries

If you want to use your speaker wirelessly, you must first insert six C LR14 No. 2 batteries (not included) into the battery compartment located at the bottom of your speaker. To insert, first push the battery compartment cover downward to remove it. Then, insert six C LR14 No. 2 batteries with the correct polarity (+,-) as displayed in the battery compartment.

Using The AC cable

Alternatively, you can use the included AC cable to power your speaker. Insert one end of the included AC cable into the AC Port on your speaker, then plug the other end into a suitable power outlet.

IMPORTANT WARNING: DO NOT use any AC cable other than the one provided by the manufacturer included inside the package. Connecting a foreign AC cable may cause your speaker to combust.

Using a Bluetooth Device

To connect your Bluetooth device to your speaker, first push the **Mode Switch (21)** to the "BT" position. By pushing the **Mode Switch (21)** away from the "OFF" position, the speaker will turn ON.

To activate Bluetooth mode, press the **CD/Bluetooth (10)** button. The LCD screen will display "BT" once Bluetooth pairing is ready.

Once your speaker is on Bluetooth mode, open the settings page on your smartphone or other Bluetooth-enabled device to turn Bluetooth ON. Then connect to the device listed as "CD Retro Boombox".

Music Controls

- Use the music controls on your connected Bluetooth device to control the music.
- Press the **Play/Pause (16)** button on the speaker to play or pause the music.
- Press and hold the **Play/Pause (16)** button to disconnect Bluetooth device.

Listening to a CD

In order for your speaker to play audio from a CD, first push the **Mode Switch (21)** to the "CD" position to turn ON CD mode. Press the **CD Compartment Cover (3)** to open it and insert the CD. Close the **CD Compartment Cover (3)**. The speaker will begin to play the first track after loading the CD. The LCD screen will display "CD" once the CD starts to play.

Music Controls

- Twist the **Volume Knob (22)** to adjust the volume.
- Press the **Play/Pause (16)** button on the speaker to play or pause the music.
- Press the **Stop (11)** button to stop the CD from playing.
- Press the **Previous (15)** button to go to the previous track.
- Press the **Next (14)** button to go to the next track.
- Press the **Repeat (12)** button once to repeat a track. Press twice to repeat the track list. Press a third time to for shuffle play. Press a fourth time to turn OFF feature.

Setting a Program

- Press the **Stop (11)** button, then press the **Program (12)** button to start setting a track order.
- Use the **Next (14)** and **Previous (15)** buttons to navigate through your track list, then press the **Program (12)** button to confirm a track selection for the program. Repeat this process for every track. You can program up to 20 tracks.
- Press the **Play/Pause (16)** button to start playing your program. While the program is playing a "P" will appear on the display screen.

Listening to a Cassette Tape

In order for your speaker to play audio from a cassette tape, first push the **Mode Switch (21)** to the "Tape/OFF" position. Press the **Cassette Stop/Open (5)** button to open the cassette compartment. Insert the cassette tape with the exposed tape side facing upwards. Push the cassette compartment to close. Press the **Cassette Play (8)** button and speaker will begin to play the first track.

Music Controls

- Twist the **Volume Knob (22)** to adjust the volume.
- Press the **Cassette Pause (4)** button on the speaker to pause the tape. Press again to resume.
- Press the **Cassette Stop/Open (5)** button to stop the tape from playing.
- Press the **Cassette Tape Fast Forward (6)** and **Fast Rewind (7)** buttons to rapidly advance or rewind the tape.

Cassette Tape Recording

- You can record audio on a new cassette tape. Press the **Cassette Play (8)** and **Cassette Recording (9)** buttons simultaneously to start recording audio from either FM, AUX-IN or CD sources.
- Use the **Mode Switch (21)** to choose your source accordingly, then play the desired audio while your cassette tape records.
- Press the **Cassette Stop/Open (5)** button to stop the recording.

Listening to the Radio

To listen to the radio, push the **Mode Switch (21)** to the "FM" position for FM radio or to the "AM" position for AM radio. The LCD screen will display the respective radio and channel number.

Music Controls

- Twist the **Tuning Knob (20)** to scroll through radio channels.
- Twist the **Volume Knob (22)** to adjust the volume.

NOTE: Adjust the direction of the speaker when the reception is facing interference on AM radio. Adjust the direction of the **FM Antenna (1)** on the speaker when the reception is facing interference on FM radio.

Inserting an AUX Cord

To use the AUX function, connect your audio device to the **AUX-IN Jack (23)** using a 3.5mm AUX cord. Then push the **Mode Switch (21)** to the "AUX" position. The LCD screen will display "AUX". Your speaker will start to play music from your connected audio device.

Music Controls

-Twist the **Volume Knob (22)** to adjust the volume.

Connecting Your Headphone

To connect your headphones, insert the headphone connector into the **Headphone Jack (24)**. This will allow the audio from the speaker to play through your headphones.

IMPORTANT NOTE: Listening at high volumes can cause hearing damage. Keep the volume at a moderate level.

Troubleshooting

| Problem | Possible Causes | Solution |
|---|--|---|
| The speaker does not work/is unresponsive | The AC power adapter is not connected to a power outlet. | Connect the power adapter to a suitable power outlet. |
| | The mode switch is not on the proper mode. | Push the mode switch to the proper music mode. |
| CD is not playing | The CD is not placed properly. | Insert the CD with the printed side up. |
| | The CD is not compatible. | Insert a Compatible CD. |
| | The CD compartment cover is not closed. | Close the CD compartment cover. |
| No Sound | The mode operation is incorrect. | Re-do the operation according to the manual. |
| | The volume is OFF/all the way low. | Turn the volume knob until you hear sound. |
| CD stops playing | The CD or laser lens is dirty. | Use a soft, clean, and dry cloth to clean the CD or laser lens. |
| | The CD is skipping. | Switch CD. |

Maintenance and Care

-Before using your speaker, inspect the ports to make sure that they are clear of dust .

-Use a soft cloth to clean your speaker. Never use any harsh chemicals or detergents. Make sure your speaker is dry before connecting.

-When your speaker is not in use, it should be stored in a cool, dry place.

-Never tug or yank on either AC cables while they are connected to your speaker. Connect and disconnect these cables as carefully as possible.

-Never expose your speaker to high temperatures, extreme cold, high humidity or excessive moisture or water.

-Please recycle or dispose of your speaker properly based on the laws and rules of your municipality. Contact local recycling facilities and/or the manufacturer of your speaker for further information.

FCC Statement

Changes or modifications not expressly approved by the party responsible for compliance could void the user's authority to operate the equipment.

This device complies with Part 15 of the FCC Rules. Operation is subject to the following two conditions: (1) this device may not cause harmful interference, and (2) this device must accept any interference received, including interference that may cause undesired operation.

This equipment has been tested and found to comply with the limits for a Class B digital device, pursuant to Part 15 of the FCC Rules. These limits are designed to provide reasonable protection against harmful interference in a residential installation. This equipment generates, uses and can radiate radio frequency energy and, if not installed and used in accordance with the instructions, may cause harmful interference to radio communications. However, there is no guarantee that interference will not occur in a particular installation.

If this equipment does cause harmful interference to radio or television reception, which can be determined by turning the equipment off and on, the user is encouraged to try to correct the interference by one or more of the following measures:

- Reorient or relocate the receiving antenna.
- Increase the separation between the equipment and receiver.
- Connect the equipment into an outlet on a circuit different from that to which the receiver is connected.
- Consult the dealer or an experienced radio/TV technician for help.

FCC Radiation Exposure Statement

The device has been evaluated to meet general RF exposure requirement.

The device can be used in portable exposure condition without restriction.

Vivitar One Year Warranty

This warranty covers the original consumer purchaser only and is not transferable.

This warranty covers products that fail to function properly UNDER NORMAL USAGE, due to defects in material or workmanship. Your product will be repaired or replaced at no charge for parts or labor for a period of one year.

What Is Not Covered by Warranty

Damages or malfunctions not resulting from defects in material or workmanship and damages or malfunctions from other than normal use, including but limited to, repair by unauthorized parties, tampering, modification or accident.

To Obtain Warranty Service and Troubleshooting Information:

Call 1-800-592-9541 or visit our website at www.vivitar.com.

To receive Warranty service along with the name and address of an authorized product service center, the original consumer purchaser must contact us for problem determination and service procedures. Proof of purchase in the form of a bill of sale or receipted invoice, evidencing that the product is within the applicable Warranty period(s), MUST be presented in order to obtain the requested service. It is your responsibility to properly package and send any defective products along with a dated copy of proof of purchase, a written explanation of the problem, and a valid return address to the authorized service center at your expense. Do not include any other items or accessories with the defective product. Any products received by the authorized service center that are not covered by warranty will be returned unrepaired.

VIVITAR®

©2023 Sakar International
195 Carter Drive
Edison, NJ 08817
Support: 800 592 9541
www.vivitar.com