

# Smart-Ex® 03 DZ1 / DZ2

User Manual

Intrinsically Safe Smartphone for  
Zone 1/21, Zone 2/22, Division 1 and  
Division 2



Your automation, our passion.

 **PEPPERL+FUCHS**

# LEGAL INFORMATION

Copyright © 2023 Pepperl+Fuchs SE. Pepperl+Fuchs logo is a trademark of Pepperl+Fuchs SE. Other product names may be trademarks or registered trademarks of the respective owners with whom they are associated.

## **Third Party Trademarks**

Google™, Android™, Google Play and other marks are trademarks of Google LLC.”

The Android robot is reproduced or modified from work created and shared by Google and used according to terms described in the Creative Commons 3.0 Attribution License.

## Table of Contents

<b>LEGAL INFORMATION.....</b>	<b>2</b>
Third Party Trademarks.....	2
<b>PHONE MODELS AND SUPPORT INFORMATION .....</b>	<b>6</b>
Phone Models Covered.....	6
Network Services.....	6
Pepperl+Fuchs Support Information.....	6
Use the Guide effectively.....	6
Common Actions.....	6
Avoid High Temperatures.....	6
Personal Medical Devices.....	7
Child Safety.....	7
Emergency Calls.....	7
<b>UNBOXING THE PHONE.....</b>	<b>8</b>
Your SIM Card.....	8
Inserting the Nano-SIM Card and Battery .....	8
eSIM activation.....	9
Charging the phone.....	9
<b>STARTING THE PHONE.....</b>	<b>11</b>
<b>THE SMART-Ex® 03 PHONE.....</b>	<b>13</b>
Home Screen Functions.....	13
Home Screen Indicators.....	14
EMM provisioning.....	15
<b>QUICK SETTINGS .....</b>	<b>16</b>
Brightness Bar.....	16
Internet (Wi-Fi Network).....	16
Bluetooth Devices.....	16
Do Not Disturb (DnD).....	16
Auto-rotate.....	16
Battery Saver.....	17
Airplane Mode.....	17
Night Light.....	17
Torch.....	17
Wi-Fi Calling (VoWiFi).....	17
Voice over 5G.....	17
Glove mode.....	17
<b>BATTERY USAGE GUIDELINES.....</b>	<b>18</b>
Charging the Battery.....	18
Verifying and Optimizing Battery Usage.....	18
Tips to extend the battery life .....	19
<b>LED INDICATORS.....</b>	<b>19</b>
<b>CALL SCREEN FUNCTIONS AND INDICATORS.....</b>	<b>19</b>
<b>CUSTOM APPLICATIONS .....</b>	<b>20</b>
eSENTINEL.....	20
eDIAGNOSTICS.....	20

<b>CAMERA</b> .....	<b>20</b>
<b>CUSTOM FEATURES</b> .....	<b>21</b>
Prog Keys (Programmable Keys).....	21
<b>SECURITY SETTINGS</b> .....	<b>21</b>
<b>FREQUENTLY ASKED QUESTIONS</b> .....	<b>21</b>
What is Pocket mode? .....	21
How can I activate Wi-Fi Calling (VoWiFi)?.....	21
How can I configure and use Speed dial? .....	22
How can I perform a system update? .....	22
How can I use the flash light settings? .....	22
<b>END USER LICENSE AGREEMENT</b> .....	<b>23</b>
License.....	23
Phone Care.....	23
Warranty.....	23
<b>COMPLIANCE AND REGULATORY</b> .....	<b>24</b>
<b>FCC STANDARD</b> .....	<b>24</b>
Compulsory FCC statement: .....	24
IC Notice .....	24
IC Radiation Exposure Statement .....	24
<b>DÉCLARATION DE LA FCC</b> .....	<b>26</b>
Déclaration obligatoire de la FCC:.....	26
Remarque IC.....	26
Déclaration d'exposition.....	26
<b>RADIO FREQUENCY (RF) ENERGY</b> .....	<b>28</b>
<b>ÉNERGIE RADIOÉLECTRIQUE</b> .....	<b>29</b>
<b>EU STATEMENT</b> .....	<b>30</b>
SAR Information.....	30
Band and Mode.....	30
Disposal of old Electrical and Electronic equipment .....	31



# PHONE MODELS AND SUPPORT INFORMATION

Congratulations on the purchase of a Smart-Ex® 03 dual-SIM smartphone. This phone is GSM/UMTS/4G/5G enabled handset. This phone has call capabilities including Voice over Wi-Fi® (VoWi-Fi). It has an intuitive, feature-rich user interface, which allows you to make the best use of the functions offered in it. This Smartphone is intended for professional users.

## Phone Models Covered

This user guide covers the different variants of Smart-Ex® 03. The model name of the device can be found on the packaging.

## Network Services

These are additional services that you can avail through your network service provider. To make the best of these services, you must subscribe to them through your service provider and obtain instructions for its use from them.

## Pepperl+Fuchs Support Information

For additional product and support information, visit <https://www.pepperl-fuchs.com>.



## Use the Guide effectively

Familiarize yourself with the terminology and symbols used in the guide to help you use your phone effectively.

<b>HOME SCREEN</b>	This is the screen displayed when the phone is in idle condition.
<b>TOUCH &amp; HOLD</b>	Touch and hold an item on the screen by touching it and not lifting your finger until an action occurs.
<b>DRAG</b>	Touch and hold an item for a moment and then, without lifting your finger, move your finger on the screen until you reach the target position.
<b>SWIPE OR SLIDE</b>	Quickly move your finger across the surface of the screen, without pausing from your first touch point. For example, you can slide a home screen left or right to view the other home screens.
<b>PINCH IN/OUT</b>	Pinch in/out on a web page, map or any other screen to zoom-in or out, respectively.

## Common Actions

Actions commonly used when accessing the Menu items on the phone are:

<b>BACK</b>		Displays the previous screen. Use the Left Selection Key to perform this function.
<b>HOME</b>		Moves the current working application to the recent applications list/background and displays the home screen.
<b>RECENT</b>		Displays recently used applications

## Limited Feature Description: Disclaimer

Your Smart-Ex® 03 smartphone comes with a feature-rich Android operating system and Google applications. This document intends to address the basic features of the phone and the applications integrated there-in. We recommend that you refer to the help and support documentation associated with each application to explore the latest features offered by them.



The Android operating system receives frequent updates. It is recommended to download and install these updates to ensure best use of your Smart-Ex® 03.

## Avoid High Temperatures

Leaving the phone in hot or cold places, such as in a closed car in summer or winter conditions, reduces the capacity and lifetime of the built-in battery. For the best results, try to keep the phone between -20°C and +60°C (-4°F and +140°F). A phone with a hot or cold battery may not work temporarily, even when the battery is fully charged. Battery performance is particularly limited in temperatures well below freezing.

**Personal Medical Devices**

Smartphones may affect the operation of cardiac pacemakers and other implanted equipment. Please avoid placing the smartphone over the pacemaker, for example in your breast pocket. When using the smartphone, place it at the ear opposite the pacemaker. If a minimum distance of 15 cm (6 inches) is kept between the smartphone and the pacemaker, the risk of interference is limited. If you suspect that interference is taking place, immediately turn off your smartphone. Contact your cardiologist for more information. For other medical devices, consult your physician and the manufacturer of the device. Comply with instructions to switch off the device or deactivate the RF transmitter when required, especially when posted in hospitals and airplanes. Equipment used in these places may be sensitive to radio waves emitted from the device and adversely affect their operation. Also, observe restrictions at gas stations or other areas with flammable atmosphere or when close to electro-explosive devices (applicable to non-Ex versions only).

**Child Safety**

This equipment is not suitable for use in locations where children are likely to be present.

**Emergency Calls**

Smartphones operate using radio signals, which cannot guarantee connection under all conditions. Therefore, you should never rely solely upon any smartphone for essential communications (e.g. medical emergencies). Emergency calls may not be possible in all areas, on all cellular networks, or when certain network services and/or smartphone features are in use. Check with your local service provider. To make emergency calls, the user can dial the emergency numbers. If the phone display is in locked state, you can long press the EMERGENCY text on the screen.

# UNBOXING THE PHONE

The Smart-Ex® 03 phone box has the following items -

- Smart-Ex® 03 phone
- Battery pack Ex-BP S03
- Wall charger
- USB cable
- Torx T8 screwdriver
- Documentation

## Your SIM Card

The SIM card associates your network services (for example, phone number, data services, and so on) with your phone. Contact your cellular network provider for the SIM card.

## Inserting the Nano-SIM Card and Battery

### Step 1

1. Unscrew the two cover screws in a counter clockwise direction.



Please use the Torx T8 screwdriver provided with the phone. Ensure that the SIM fits correctly into the slot and the contact is complete.

2. Remove the battery.

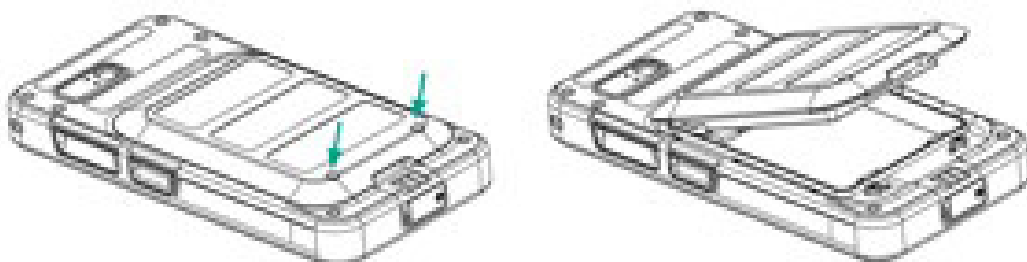

### Step 2

1. Insert the Nano-SIM card with the gold colored contacts facing downwards.
2. Push it upwards into the designated slot.



Ensure that the SIM fits correctly into the slot and the contact is complete. Please use the screwdriver Torx T8. Ensure not to over tighten the screws.

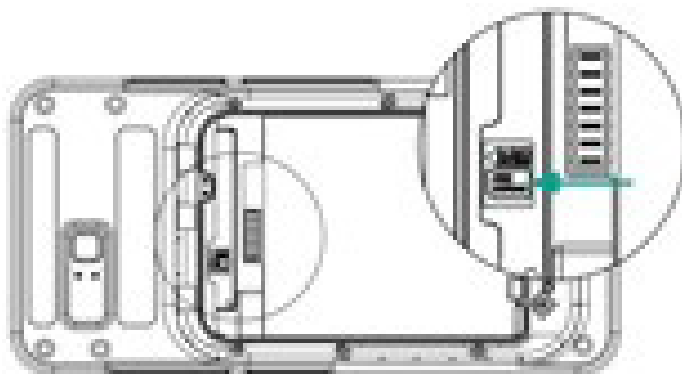



### Step 3

1. Insert the battery into the battery slot in the prescribed order as shown in the figure and screw down the two cover screws in a clockwise direction.

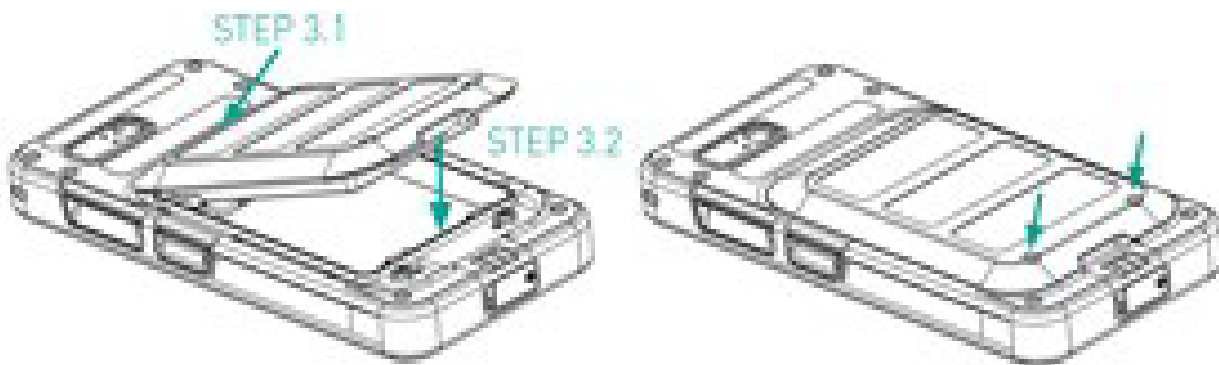

### eSIM activation

Send a request for eSIM to the cellular network operator. A QR code is sent via email to activate the same.

1. Go to Settings-> Network and Internet-> SIMs
2. Click Add to add a new SIM.

Follow the wizard instructions to download and activate the eSIM. You will be prompted to scan the QR code sent by the cellular service provider. The activation process will follow and complete. Once activated the eSIM is set as your default SIM for calls. The physical SIM gets deactivated.

 In case you are performing a factory reset of the mobile phone, please ensure that the eSIM profile is retained. If you choose to erase it, you will need to contact the network provider again for the activation code.

### Charging the phone

1. Connect the USB end of the cable to the phone and the other end to the socket.
2. Plug in the wall charger socket into a power source. The screen lights up showing the battery charging icon at the display. Also the LED indicator at the top of the phone, shows RED when the charging is in progress and changes to GREEN once the charging is complete.

On completion that is 100% charge disconnect the USB cable from the phone.

 Do not over charge. Maximum time required for full charge is 2.5 hours.

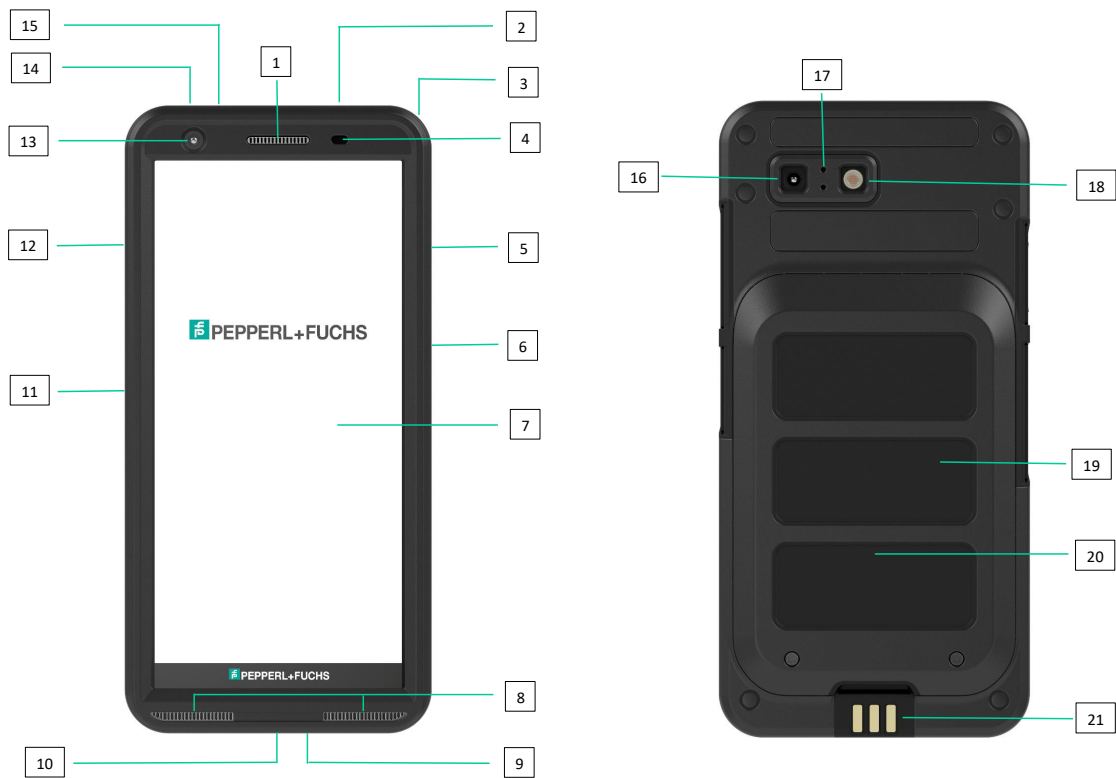

1. Ear-piece
2. Headset / RSM interface
3. Eyelet
4. Proximity / Light sensor
5. Multifunction key right
6. Power key with fingerprint sensor
7. Touchscreen
8. Loudspeakers
9. Microphone
10. USB-C interface
11. Multifunction key left
12. Volume key
13. Front camera
14. Alarm key
15. Notification LED
16. Rear camera
17. Noise canceling microphone
18. Flash LED
19. Battery
20. NFC antenna
21. Charging contacts

NOTE: The USB-C interface does not support 3.5mm audio adapter for audio.

# STARTING THE PHONE

After switching on the new Smart-Ex® 03 phone a START button is visible at the center of the screen. The START button provides access to the Wi-Fi section. The phone requests for a Wi-Fi connection.

1. Click on the START button to set up your phone.

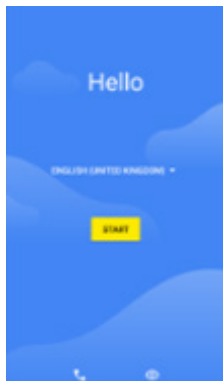

2. Select your network from the list of displayed networks. OR select the Setup Offline option to continue in the offline mode.

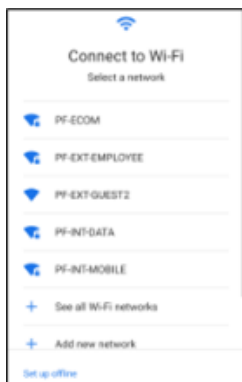

3. Enter the password. Select Advanced options, if any of the advanced parameters have to be changed.



4. Click the CONNECT button. The Password is authenticated and connection is established. Google Sign-in page is displayed.

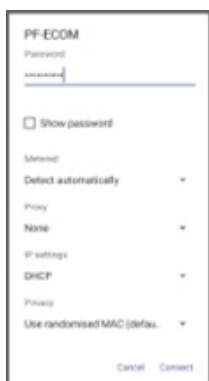

5. The Google Sign-in page is displayed. To continue Sign-in with an authentic email id.

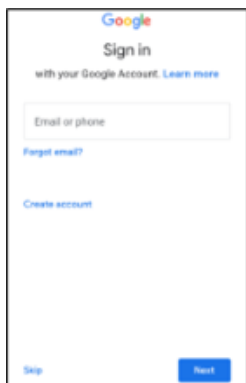

If you select the offline mode, follow these steps:

1. Click on Continue to set up your phone in the Offline mode OR click on Back to connect to a Wi-Fi network. A list of Wi-Fi networks is displayed.

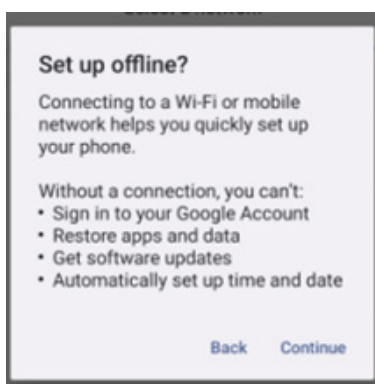

2. If you select the Setup Offline option, the Google Services page is displayed. Accept and follow the wizard steps to set up your phone.

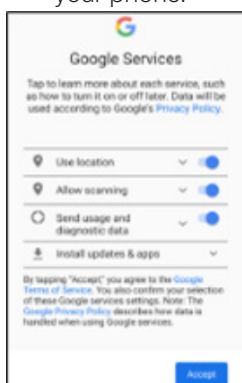

# THE SMART-Ex<sup>®</sup> 03 PHONE

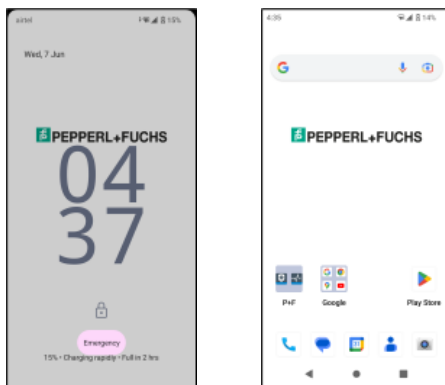



Basic apps like the Call Dialer, SMS, Calendar, Contacts, Camera are visible on the Home screen. Follow the wizard to download your data and activate these apps. You can drag and drop your favorite apps to the Home Screen for easy access. Swipe up to see all the apps available. Standard apps such as Chrome, Calendar, Calculator, Files, Messages, etc. are available on the phone. Additionally, you can download the apps of your choice from the Google Play<sup>®</sup> store.

Some of the features of an Android phone are further detailed here for your understanding. Features specific to the Smart-Ex<sup>®</sup> 03 are elaborated in the Custom Features section.

## Home Screen Functions

























After you complete the phone setup, the Home screen is displayed. This is the start point to access all the features of this device. The Home screen has multiple panels, it includes -

- Time indicator: Shows the current time as per the time zone selected.
- Network strength indicator: This indicates the Network strength of the service provider.
- Battery charge indicator: Indicates the charge status of the battery.
- Status bar: The Status bar at the top of the screen provides notification such as missed call, new messages, alarms, events, software updates, etc.
- Google search bar: Google Search bar lets you search for items in your phone or the Internet. Touch Google Search bar to type your search terms, or to speak and give a voice input.
- App icons: The app icons added to the Home screen are displayed here. You can drag and place app icons on the Home screen for quick access. You can group widgets of apps and create folders.
- Soft Keypad functions: The following table displays the various soft keys and the corresponding functions they perform:

Icons	Description
	Back - Press this key to go back to the previous screen. You can press till you reach the Home screen too.
	Home - Moves the current working application to the recent applications list/background
	Recent - displays the recently accessed applications.

## Home Screen Indicators

The icons displayed at the top of the screen provide information about the status of the device. Details such as date and time, battery charge status, and data service and Wi-Fi connectivity are displayed when the phone is in standby mode. Other indicators such as airplane mode, alarm and call forward are displayed, if the feature is activated.

Icons	Description
	Battery level indicator
	Low Battery
	Battery charging in progress
	Battery saver mode
	No signal
	Signal strength
	No SIM card
	4G Network connected
	5G Network Connected
	5-Gigahertz Network connection
	Roaming
	EDGE network connected
	Wi-Fi connected
	Call in progress
	Missed call
	VoWi-Fi Registered
	New SMS or MMS
	New E mail
	Alarm activated
	Do Not Disturb (DnD) activated
	Vibration mode activated
	Silent mode
	Airplane mode activated
	Synced with the associated account such as Google



Screenshot captured



Bluetooth Headset connected

### **EMM provisioning**

In an enterprise environment, mobile devices are typically enrolled into an Enterprise Mobility Management (EMM) system. There are many solution providers for such provisioning who provide different activation methods. The solution may also integrate Google's Android Zero Touch (AZT) provisioning method. These methods simplify the provisioning and management of the device in the enterprise.

# QUICK SETTINGS

Quick settings give quick access to the most frequently used settings from the status bar.

- Drag down the status bar to access the quick settings.
- Tap to view the complete list of settings present in the quick settings.
- To add or remove a setting to/from the quick settings, tap Edit (  ).

Each Quick settings option is detailed below:

## Brightness Bar

Drag the Brightness bar towards your right to increase the brightness of the screen. To reduce the brightness, drag it towards the left.

## Internet (Wi-Fi Network)

Tap on the Internet button to see the list of Internet connections available. By default, it displays the name of the active connection. Wi-Fi is a wireless network technology that provides Internet access to your smart phone. You can access Internet when you connect your Smart-Ex® 03 to a Wi-Fi network.

Follow these steps to connect your phone to a Wi-Fi network -

1. Tap on a Wi-Fi router present within your phone's accessible range as displayed in the list.
2. Tap your preferred network. Enter the password (if it is a secured network) and tap Connect.

## Bluetooth Devices

- Bluetooth is short-range wireless communication technology used to communicate between the devices. Use Bluetooth headphones to attend calls.

### *Activating Bluetooth*

Tap the Bluetooth button to activate Bluetooth.

Tap and hold to see the Connected Devices. This screen shows a list of devices previously connected as also other devices available in the vicinity for pairing.

### *Pairing a Bluetooth Device*

To pair your Smart-Ex® 03 phone with other Bluetooth devices:

1. On the Quick Settings screen, tap the Bluetooth button.

OR

1. From the Home / All Apps screen, tap Settings (  ) -> Connected devices. A list of accessible Bluetooth devices is displayed. Ensure that Bluetooth is activated in the other device too.
2. Tap Pair new device to search and add other Bluetooth enabled devices. A list of accessible Bluetooth devices is displayed.
3. Tap Settings next to the specific paired device to connect the Bluetooth device to access your phone's contacts, call history and also provide Internet access.
4. Enable Media Audio to connect the Bluetooth device for listening to media files.



This option is displayed only when a Bluetooth Headset /car kit is connected.

5. Confirm the pass key in the other device and tap to pair in your phone.
6. The device is displayed in the Paired device list.

## Do Not Disturb (DnD)

Tap on the Do not Disturb (DnD) button in the Quick Settings list to active it. Notifications are not displayed when DnD is active.

## Auto-rotate

Tap on the Auto-rotate button in the Quick Settings list to active it.

The screen display automatically turns to horizontal/vertical position or vice versa depending on the application that is open.



## **Battery Saver**

Tap on the Battery Saver button in the Quick Settings list to activate it.

It reduces the background activity in the phone, reduces the brightness of the screen, and saves battery charge. This enables the user to operate the phone for a longer duration.

## **Airplane Mode**

Tap to activate the Airplane mode.

When your phone is set to airplane mode, network connectivity or mobile data connectivity is disabled. You cannot make/receive phone calls in this mode. You can access your media files and other features that do not require Internet/mobile data connectivity.

## **Night Light**

Tap to activate the Night Light mode.

Night Light when activated reduces the brightness of the screen and emits a background light to enable access in dark places.

## **Torch**

Tap on the Torch button to switch on the Torch Light.



The Torch cannot be switched on if the Camera app is active.

## **Wi-Fi Calling (VoWiFi)**

With Wi-Fi Calling, you can dial or receive a phone call if you have a Wi-Fi connection in an area with little or no cellular coverage. Please ensure that this feature is provided by your service provider.

To activate Wi-Fi calling (VoWiFi), tap Phone > Settings > Calling accounts > Operator name > Wi-Fi calling. You may also activate this feature from the Quick settings options.

## **Voice over 5G**

The Smart-Ex 03 can support Voice calls over 5G where the network is capable of this service and the phone has been provisioned with the feature. To activate the Voice over 5G (VoNR) feature tap Settings -> Network and Internet -> SIMs -> Voice over 5G.

## **Glove mode**

Tap on the Glove Mode button to activate it.

When using gloves the touch functionality of the device may not work satisfactorily. In order to improve the experience you will need to activate the glove mode.

# BATTERY USAGE GUIDELINES

The Smart-Ex® 03 phone comes with a removable battery. For any battery-related queries contact Pepperl+Fuchs customer support.



Use only Pepperl+Fuchs certified charger and USB cable to charge your Smart-Ex® 03.

## Charging the Battery

The battery delivered with your smartphone is not fully charged. We recommend to fully charge the battery before using the smartphone for the first time. The full capacity of the battery is reached after 3 to 4 complete charge/discharge cycles.



There is a risk of explosion while charging if the battery has been replaced by an incorrect type.  
Dispose of used batteries according to the instructions

1. Insert the charger plug into a power outlet.
2. Connect to Phone: The charging port is located at the lower end of the phone. Insert the USB (C type) connector to the charging port. Open the USB cover and rotate it 180° to fix it in place. After that the USB (C type) connector can easier be connected.

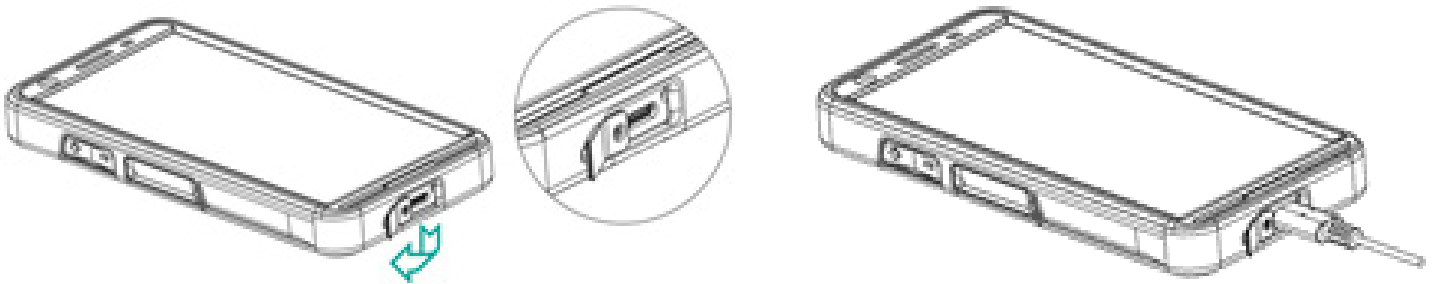

3. Charging Animation/Icon:

If the battery is being charged when the phone is switched off, a battery charging animation with charged percentage is displayed.

If the battery is being charged while the phone is switched on, the battery charge icon on the home screen top-right corner shows animation indicating that the battery is being charged. After the phone is fully charged the charging animation stops and you can disconnect the charger from the phone.

The LED indicator at the top of the phone, shows RED when the charging is in progress and changes to GREEN once the charging is complete.



Charging your Smart-Ex® 03 with a different cable/charger and/or in a hazardous environment will compromise the intrinsically safe nature of the device.

## Verifying and Optimizing Battery Usage

To check the battery usage status, select Settings -> Battery. The current battery charge status and the charge level details are displayed.

The discharge graph (visible upon tapping the Battery usage option) shows the battery level over time since you last charged the device. The list at the bottom of the screen shows the breakdown of battery usage for individual applications and services. Touch any listed item for more details. The details screen for some applications includes options that allow you to adjust settings affecting power usage, or stop the app completely.



If you stop some system apps or services such as Google service, your device may not work correctly.

## Tips to extend the battery life

Follow these tips to extend your phone's battery life.

- If you are using Wi-Fi, Bluetooth or GPS, use the Quick Settings or Phone Settings to turn it off.
- Limit usage of location-based application.
- Set screen brightness to Auto and set a shorter sleep timeout (1 minute). The display settings are located in Settings -> Display.

# LED INDICATORS

At the top end of the phone an LED indicator is placed (next to the red button). This LED indicator flashes with three different colors, namely red, blue and green.

- Red color: The Red color blinking LED light indicates that the battery level is low (less than 15%) and the phone needs to be charged. A constant red colored indicates that charging is in progress.
- Blue color: Blue color blinking LED light indicates missed events, such as a missed call, new message or a calendar notification.
- Green color: Green color indicates that the battery has been charged completely and the charger should be unplugged from the power source.

# CALL SCREEN FUNCTIONS AND INDICATORS

You can modify the call settings as per your choice.

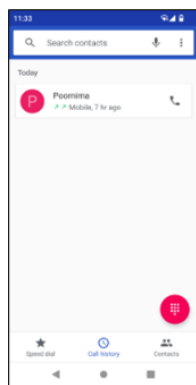

From Home or All Apps screen, tap Phone ( 📞 ). The Phone screen displays a list of calls made recently. The action panel displays the Speed dial ( ★ ), Call History ( 🕒 ) and Contacts ( 👤 ) icons.

The Search bar at the top of the screen allows you to search for a contact. Enter the first few letters/numbers of the contact name/phone number to be searched. All the contacts containing the search text are displayed.

Tap on the dial pad ( 📞 ) to call a number directly.

To dial a number use one of the following options:

- Speed dial: Tap the specific contact/number from the frequently called numbers to make a call.
- Call history: Tap the call history icon ( 🕒 ) to view the call history. To make a call, tap the contact/number and tap the phone icon ( 📞 ).
- Contacts: Tap a specific contact and tap the phone number to dial a call.

# CUSTOM APPLICATIONS

There are two custom applications specific to Smart-Ex® 03 phone, namely – eSentinel and eDiagnostics.

## eSENTINEL

This application allows you to configure alarm systems. There are five types of alarms that can be set up for different situations. Widgets for these have been placed on the Home screen. Set up the alarms in the Red Button section.

These are 'Lone Worker Safety application' settings that can be predefined to assist personnel working solo.

## eDIAGNOSTICS

eDiagnostics allows you to check the functionality of each feature present on the phone. The IT Admin of the organization checks the health of the phone and rectifies issues reported by the personnel.

## CAMERA

The Camera feature of this phone allows the user to capture pictures and video in two modes each.

- Videos can be captured in normal Video mode. The HFR mode gives high-resolution videos.
- Photo and ProMode are the two capture qualities that give normal and high-resolution pictures, respectively.

### *Flash*

The Flash can be used in two modes – Auto and HDR.

Auto: In Auto mode, the flash comes on depending on the ambient light required for the picture.

HDR: Higher resolution photographs require flash to capture the details of the object.



The flash can be switched off, if it is not required.

When using the phone camera application the Torch cannot be switched on.

# CUSTOM FEATURES

## Prog Keys (Programmable Keys)

This option allows you to assign various functions to a specific key.

For example, the button above the power button is assigned to the Camera. It could be modified with this option and assigned to another function.

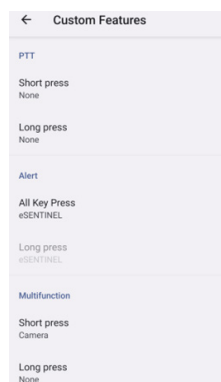

### *PTT (Push to talk):*

This key is located below the volume button. It works as a one-way radio communicator with the base station.

- Hold the button while speaking; release it to receive a reply.
- Short press or Long press of the key can be assigned to different functions.

### *Alert Key*

There are two options to activate an Alert.

- All Key Press: This can be assigned to eSentinel which in turn send out an alert message.
- Long Press: A long press key can be assigned to send an alert.

### *Multifunction*

Multiple functions can be assigned via the Short press/Long press option.

# SECURITY SETTINGS

There are three ways to ensure that your phone is secure and cannot be misused by any other person.

Go to Settings->Security->Device Security. You can lock your phone with a Fingerprint, PIN, or a Pattern. Follow the wizard to create your own unique lock.



The sensor to capture your fingerprint is present on the Power button.

# FREQUENTLY ASKED QUESTIONS

## **What is Pocket mode?**

Pocket mode allows you to avoid accidental screen touches or any operation when the phone is in your pocket. If activated, all screen touches are disabled, so the phone won't try to unlock itself or dial a number or call any number from your Contacts.

## **How can I activate Wi-Fi Calling (VoWiFi)?**

When Wi-Fi Calling is activated, you can dial or receive a phone call if you have a Wi-Fi connection in an area with little or no cellular coverage. Please ensure that this service is provided by your service provider.

To activate Wi-Fi calling (VoWiFi), tap Phone -> Settings -> Calling accounts -> Operator name -> Wi-Fi calling.

**How can I configure and use Speed dial?**

Speed dialing helps you to associate each numeric key with one of the frequently used contact or phone number. If the user long presses the numeric key, the associated contact/number will be dialed. However, numeric key '1' is associated with voice mail and speed dial cannot be associated with it.

To activate speed dial, tap Call Settings -> Speed Dial settings.

**How can I perform a system update?**

You can update your device OS by checking for updates under Settings ->System -> System update.

If there is any system update to be performed, your phone directly communicates with the server via Wi-Fi/Mobile data and updates the device OS. Wi-Fi is the preferred mode for download of update as mobile data incurs additional charges including roaming.

**How can I use the flash light settings?**

This setting helps you to restrict the accidental usage of flash light. To turn ON/OFF Flash, tap Settings ->System -> Custom Feature. Once turned OFF, the flash bulb will not be available for Camera flash and Torch.

# END USER LICENSE AGREEMENT

## License

This wireless device, (the “Device”) contains software owned by PEPPERL+FUCHS SE. (“Pepperl+Fuchs”) and its third party suppliers and licensors (collectively, the “Software”). As user of this Device, Pepperl+Fuchs grants you a non-exclusive, non-transferable, non-assignable license to use the software solely in conjunction with the Device on which it is installed and/or delivered with. Nothing herein shall be construed as a sale of the Software to a user of this Device.

You shall not reproduce, modify, distribute, reverse engineer, decompile, otherwise alter or use any other means to discover the source code of the Software or any component of the Software. For avoidance of doubt, you are at all times entitled to transfer all rights and obligations to the Software to a third party, solely together with the Device with which you received the Software, provided always that such third party agrees in writing to be bound by these rules.

You are granted this license for a term of the useful life of this Device. You can terminate this license by transferring all your rights to the Device on which you have received the Software to a third party in writing. If you fail to comply with any of the terms and conditions set out in this license, it will terminate with immediate effect Pepperl+Fuchs and its third party suppliers and licensors are the sole and exclusive owner of and retain all rights, title and interest in and to the Software. Pepperl+Fuchs, and, to the extent that the Software contains material or code of a third party, such third party, shall be entitled third party beneficiaries of these terms. The laws of Delaware, United States shall govern the validity, construction and performance of this license.

## Phone Care

Each Pepperl+Fuchs Phone has a designated IP class for dust and water protection, according to the EN/IEC Ingress Protection (IP) Standard 60529. This means that the phone is dust protected and can be submerged into 3.3 feet/1.0 m deep water for up to 31 minutes. Immersion in deeper water can damage it and must be avoided.

Pepperl+Fuchs phones are built for heavy duty use. Its design protects against disassembly or mechanical damage when subjected to forces equal to free fall from the height of 4.9 feet/1.5 meters. Subjecting the phone to stronger impact and forces can damage it and must be avoided.

## Warranty

Please observe the User manual provided in the Sales kit of this device for details about the warranty.

 Changes or modifications made to this equipment not expressly approved by PEPPERL+FUCHS SE for compliance could void the user’s authority to operate the equipment.

# COMPLIANCE AND REGULATORY

## FCC STANDARD

- This Smart-Ex® 03 variant targeted for the North American region complies with part 15 of the FCC rules (FCC ID: 2AXZAS03GR01). Operation is subject to the following two conditions:
- This device may not cause harmful interference.
- This device must accept any interference received, including interference that may cause undesired operation.
- This device has been tested and found to comply with the limits for a Class B digital device, pursuant to Part 15 of the FCC Rules. These limits are designed to provide reasonable protection against harmful interference in a residential installation. This equipment generates, uses, and can radiate radio frequency energy, and, if not installed and used in accordance with the instructions, may cause harmful interference to radio communications. However, there is no guarantee that interference will not occur in a particular installation. If this equipment does cause harmful interference to radio or television reception, which can be determined by turning the equipment off and on, the user is encouraged to try to correct the interference by one or more of the following measures:
  - Reorient or relocate the receiving antenna.
  - Increase the separation between the equipment and receiver.
  - Connect the equipment into an outlet on a circuit different from that to which the receiver is connected.
  - Consult the dealer or an experienced radio/TV technician for help.

 The country code selection is for non-US model only and is not available to all US model. Per FCC regulation, all Wi-Fi product marketed in US must fixed to US operation channels only.

- Hearing Aid Compatibility (HAC) — U.S. only
- This device is hearing aid compatible as determined by ANSI C63.19-2011.
- This standard has two ratings: M (for reduced radio-frequency interference to enable acoustic coupling) and T (for inductive coupling with hearing aids operating in telecoil mode) on a scale from 1-4, where 4 is most compatible.
- This device is rated M3/T3.

### Compulsory FCC statement:

- This phone has been tested and certified for use with hearing aids for some of the wireless technologies that it uses. However, there may be some newer wireless technologies used in this phone that have not been tested yet for use with hearing aids. It is important to try the different features of this phone thoroughly and in different locations, using your hearing aid or cochlear implant, to determine if you hear any interfering noise. Consult your service provider or the manufacturer of this phone for information on hearing aid compatibility. If you have questions about return or exchange policies, consult your service provider or phone retailer.

### IC Notice

This device complies with Industry Canada license-exempt RSS standard(s). Operation is subject to the following two conditions:

- This device may not cause interference, and
- This device must accept any interference, including interference that may cause undesired operation of the device.

This Class B digital apparatus complies with Canadian ICES003 (IC: 7037A-S03GR01).

### IC Radiation Exposure Statement

This EUT is in compliance with SAR for general population/uncontrolled exposure limits in IC RSS-102 and had been tested in accordance with the measurement methods and procedures specified in IEEE 1528 and IEC 62209. This equipment should be installed and operated with minimum distance of 10 mm between the radiator and your body. This device and its antenna(s) must not be co-located or operating in conjunction with any other antenna or transmitter. The use of WLAN band is restricted to indoor use only.



**Caution:**

- 1) The device for operation in the band 5150–5250 MHz is only for indoor use to reduce the potential for harmful interference to co-channel mobile satellite systems.
- 2) Operation of transmitters in the 5.925-7.125 GHz band is prohibited for control of or communications with unmanned aircraft systems.
- 3) Devices shall not be used for control of or communications with unmanned aircraft systems.

# DÉCLARATION DE LA FCC

- Cette variante Smart-Ex 03 ciblée pour la région Amérique du Nord est conforme à la partie 15 des règles de la FCC (FCC ID: 2AXZAS03GR01). Le fonctionnement est soumis aux deux conditions suivantes:
- L'appareil ne doit causer aucune interférence nuisible. →
- Cet appareil doit accepter toutes les interférences reçues, y compris les interférences pouvant causer un fonctionnement non désiré. →
- L'appareil a été testé et déclaré conforme aux limites pour les appareils numériques de classe B, selon la section 15 des règlements de la FCC. Ces normes visent à fournir aux installations résidentielles une protection raisonnable contre les interférences nuisibles. Cet équipement génère, utilise et peut émettre de l'énergie radio électrique et, s'il n'est pas installé et utilisé conformément aux présentes instructions, peut causer des interférences nuisibles aux communications radiophoniques. Il n'existe toutefois aucune garantie que de telles interférences ne se produiront pas dans une installation particulière. Si cet appareil cause des interférences nuisibles à la réception des signaux de la radio ou de la télévision, ce qui peut être déterminé en éteignant et en allumant l'appareil, l'utilisateur est encouragé à essayer de corriger les interférences par une ou plusieurs des mesures suivantes:
- Réorienter ou repositionner l'antenne de réception. →
- Augmenter la distance entre l'équipement et le récepteur. →
- Branchez l'équipement à une prise sur un circuit différent de celui auquel le récepteur est branché. →
- Consulter le fournisseur ou un technicien radio/TV qualifié pour obtenir une assistance.



La sélection du code de pays est uniquement pour le modèle non US et n'est pas disponible pour tous les modèles US. Selon la réglementation de la FCC, tous les produits Wi-Fi commercialisés aux États-Unis doivent uniquement être connectés aux canaux d'exploitation américains seulement.

- Compatibilité des aides auditives (HAC) — États-Unis seulement
- Ce dispositif est compatible avec l'aide auditive, tel que déterminé par l'ANSI C63.19-2011.
- Cette norme a deux cotes: M (pour les interférences radio-fréquence réduites pour permettre le couplage acoustique) et T (pour inductive) couplément avec des aides auditives fonctionnant en mode télécoïl) sur une échelle de 1 à 4, où 4 est le plus compatible.
- Ce dispositif est classé M3/T3.

## Déclaration obligatoire de la FCC:

- Ce téléphone a été testé et certifié pour une utilisation avec des aides auditives pour certaines des technologies sans fil qu'il utilise. Cependant, il peut y avoir certaines nouvelles technologies sans fil utilisées dans ce téléphone qui n'ont pas encore été testées pour une utilisation avec des appareils auditifs. Ça fait il est important d'essayer les différentes fonctionnalités de ce téléphone à fond et à différents endroits, en utilisant votre aide auditive ou cochléaire implant, pour déterminer si vous entendez un bruit interférent. Consultez votre fournisseur de services ou le fabricant de ce téléphone pour informations sur la compatibilité des aides auditives. Si vous avez des questions sur les politiques de retour ou d'échange, consultez votre fournisseur de services ou détaillant de téléphon

## Remarque IC

Cet appareil est conforme aux Normes RSS d'Industry Canada. Son utilisation est soumise à deux conditions: →

- Ce dispositif ne peut pas provoquer d'interférences, et →
- Ce dispositif doit accepter toutes les interférences reçues, y compris les interférences susceptibles de provoquer un fonctionnement non souhaité.

Cet appareil de classe B est conforme à la norme canadienne ICES-003 (IC: 7037A-S03GR01).

## Déclaration d'exposition

IC Cet EUT est conforme aux valeurs SAR à la norme SAR pour le grand public ainsi qu'aux limites d'exposition non réglementée IC RSS-102 et a été testé selon les méthodes et procédures spécifiées par les Normes IEEE 1528 et IEC 62209. Cet appareil devrait être installé et utilisé en respectant une distance minimale de 10 mm avec votre corps. Cet appareil et son (ses) antenne (s) ne doivent pas être situés à proximité l'un de l'autre et ne doivent pas fonctionner en même temps qu'une autre antenne ou qu'un autre émetteur. L'utilisation de la bande WLAN est limitée à une utilisation en intérieur.

**Avertissement:**

- 1) Le dispositif fonctionnant dans la bande 5150-5250 MHz est reserve uniquement pour une utilisation a l'interieur afin de reduire les risques de brouillage prejudiciable aux systemes de satellites mobiles utilisant les memes canaux.
- 2) L'exploitation d'émetteurs dans la bande 5,925-7,125 GHz est interdite pour le contrôle ou les communications avec des systèmes d'avions sans pilote.
- 3) Les dispositifs ne doivent pas être utilisés pour commander des systèmes d'aéronef sans pilote ni pour communiquer avec de tels systèmes.

# RADIO FREQUENCY (RF) ENERGY

This device is designed and manufactured not to exceed the emission limits for exposure to radio frequency (RF) energy set by the Federal Communications Commission of the United States and Industry Canada.

During SAR testing, this device is set to transmit at its highest certified power level in all tested frequency bands, and placed in positions that simulate RF exposure in usage against the head with no separation, and near the body with the separation of 10 mm. Although the SAR is determined at the highest certified power level, the actual SAR level of the device while operating can be well below the maximum value. This is because the device is designed to operate at multiple power levels so as to use only the power required to reach the network. In general, the closer you are to a wireless base station antenna, the lower the power output.

The exposure standard for wireless devices employing a unit of measurement is known as the Specific Absorption Rate, or SAR. The SAR limit set by the FCC is 1.6 W/kg and 1.6 W/kg by Industry Canada.

This device is in compliance with SAR for general population /uncontrolled exposure limits in ANSI/IEEE C95.1-1992 and Canada RSS 102 and had been tested in accordance with the measurement methods and procedures specified in IEEE1528 and Canada RSS 102. This device has been tested and meets the FCC and IC RF exposure guidelines when tested with the device directly contacted to the body.

For this device, the highest reported SAR value for usage,

- By the head is 0.62 W/Kg (1 g)
- Worn on the body is 0.9 W/Kg (1 g)
- Used as hotspot is 0.7 W/Kg (1g)

While there may be differences between the SAR levels of various devices and at various positions, they all meet the government requirement.

SAR compliance for body-worn operation is based on a separation distance of 10 mm between the unit and the human body. Carry this device at least 0 mm away from your body to ensure RF exposure level compliant or lower to the reported level. To support body-worn operation, choose the belt clips or holsters that do not contain metallic components to maintain a separation of 0 mm between this device and your body.

RF exposure compliance with anybody-worn accessory, which contains metal, was not tested and certified, and using such body-worn accessory should be avoided.

# ÉNERGIE RADIOÉLECTRIQUE

Cet appareil est conçu et fabriqué de façon à ne pas dépasser les limites d'émission pour l'exposition à l'énergie de radiofréquence (RF) fixées par la Federal Communications Commission des États-Unis et Industrie Canada.

Au cours des essais SAR, cet appareil est configuré pour transmettre des données à son niveau de puissance le plus élevé à toutes les bandes de fréquences testées et placées dans l'ensemble des positions simulant l'exposition aux radiofréquences contre la tête et près du corps, avec une séparation de 10 mm. Bien que le DAS soit déterminé par le niveau de puissance le plus élevé, le niveau SAR réel de l'appareil en fonctionnement peut être bien inférieur à la valeur maximale indiquée. Cela est dû au fait que l'appareil est conçu pour fonctionner à plusieurs niveaux d'alimentation, pour s'adapter aux capacités des différents réseaux électriques. De manière général, plus vous vous trouvez près d'une station sans fil, plus la fréquence de transmission sera basse.

La norme d'exposition pour les dispositifs sans fil employant une unité de mesure est connue sous le nom de taux d'absorption spécifique (SAR). La limite SAR fixée par la FCC est de 1.6 W / kg et de 1.6 W / kg par Industry Canada.

Cet appareil est conforme à la norme SAR pour le grand public ainsi qu'aux limites d'exposition non réglementées ANSI / IEEE C95.1-1992 et Canada RSS 102, et a été testé conformément aux méthodes et procédures spécifiées par les Normes IEEE1528 et Canada RSS 102. Ce dispositif a été testé et respecte les directives FCC et IC sur l'exposition aux radiofréquences lorsqu'il est testé en contact direct avec le corps.

Pour cet appareil, la valeur SAR la plus élevée signalée pour l'utilisation,

- Par la tête est de 0.62 W/Kg (1 g)
- Porté sur le corps: 0.9 W/Kg (1 g)
- Utilisé comme point chaud: 0.7 W/Kg (1 g)

Bien qu'il puisse exister des différences entre les niveaux de SAR selon les dispositifs et les emplacements où ils sont utilisés, tous répondent aux exigences Gouvernementales.

La valeur SAR déclarée conforme est une distance de 10 mm entre l'unité et le corps humain. Eloignez cet appareil à une distance d'au moins 0 mm de votre corps pour vous assurer que le niveau d'exposition aux RF est conforme ou inférieur au niveau indiqué. Vous pouvez également opter pour un étui ne contenant aucun composant métallique, pour maintenir une séparation de 0 mm entre cet appareil et votre corps.

Pour tout appareil contenant du métal, la conformité de l'exposition aux radiofréquences n'a pas encore été testée / certifiée de manière précise.

# EU STATEMENT

## SAR Information

The Smart-Ex® 03 has been certified in compliance with the Government's requirements for exposure to Radio Waves.

When communicating over the wireless network, the smartphone emits via the radio frequency waves, low levels of radio energy. The Specific Absorption Rate, or SAR, is the amount of RF energy absorbed by the body while using the phone and is expressed in watts/kilogram (W/kg).

Governments around the world have adopted comprehensive international safety guidelines, developed by scientific organizations, for example, ICNIRP (International Commission on Non-Ionizing Radiation Protection) and IEEE (The Institute of Electrical and Electronics Engineers Inc.). These guidelines establish permitted levels of radio wave exposure for the general population.

Tests for SAR are conducted using standardized methods with the phone transmitting at its highest certified power level in all used frequency bands.

SAR Data Information for residents in countries that have adopted the SAR limit recommended by the International Commission on Non-Ionizing Radiation Protection (ICNIRP), for example, European Union, Japan, Brazil and New Zealand is available.

A minimum separation distance of 0 mm must be maintained between the user's body and the device, including the antenna during body-worn operation to comply with the RF exposure requirements in Europe. The limit recommended by ICNIRP is 2 W/kg averaged over ten (10) grams of tissue.

The following SAR values are applicable to Smart-Ex® 03 smartphones. This variant is available globally.

The highest SAR value for the Smart-Ex® 03 ROW phone when tested by Pepperl+Fuchs for use:

- By the head is 1.78 W/Kg (10 g).
- Worn on the body and by limbs is 1.84 W/Kg (10 g).

## Band and Mode

Band and Mode		Output Power
<b>GSM (2G)</b>		
GSM 900	900 MHz	33 dBm
GSM 1800	1800 MHz	30 dBm
<b>WCDMA (3G)</b>		
Band I	2100 MHz	24 dBm
Band VIII	900 MHz	24 dBm
<b>LTE (4G)</b>		
Band 1	2100 MHz	24 dBm
Band 3	1800 MHz	24 dBm
Band 7	2600 MHz	24 dBm
Band 8	900 MHz	24 dBm
Band 20	800 MHz	24 dBm
Band 28	700 MHz	24 dBm
Band 38	2600 MHz	24 dBm
Band 40	2300 MHz	24 dBm
<b>NR (5G)</b>		
Band n1	2100 MHz	24 dBm
Band n3	1800 MHz	24 dBm
Band n7	2600 MHz	24 dBm

Band n8	900 MHz	24 dBm
Band n20	800 MHz	24 dBm
Band n28	700 MHz	24 dBm
Band n38	2600 MHz	24 dBm
Band n40	2300 MHz	24 dBm
Band n77	3700 MHz	24 dBm
Band n78	3500 MHz	25 dBm
<b>Bluetooth</b>		
	2400 MHz	8.5 dBm
<b>Bluetooth LE</b>		
	2400 MHz	8.5 dBm
<b>WiFi</b>		
	2400 MHz	20 dBm
	5000 MHz	20 dBm
	5800 MHz	14 dBm
	6000 MHz	20 dBm
<b>NFC</b>		
	13.56 MHz	14.89 dBuA/m @ 10m

The use of WLAN band is restricted to indoor use only.  
This restriction will be applied in all EU member states.

<b>AT</b>	<b>BE</b>	<b>BG</b>	<b>CH</b>	<b>CY</b>	<b>CZ</b>	<b>DE</b>	<b>DK</b>	<b>EE</b>	<b>ES</b>	<b>EL</b>
<b>FI</b>	<b>FR</b>	<b>HR</b>	<b>HU</b>	<b>IE</b>	<b>IS</b>	<b>IT</b>	<b>LI</b>	<b>LT</b>	<b>LU</b>	<b>LV</b>
<b>MT</b>	<b>NL</b>	<b>NO</b>	<b>PL</b>	<b>PT</b>	<b>RO</b>	<b>SE</b>	<b>SI</b>	<b>SK</b>	<b>TR</b>	<b>UK</b>

## Disposal of old Electrical and Electronic equipment



The symbol of the crossed-out wheeled bin indicates that within the countries in the European Union, this product, and any enhancements marked with this symbol, cannot be disposed of as unsorted waste but must be taken to separate collection at their end-of-life.



Dispose of batteries in accordance with European Directive BattV (EU) 2023/1542  
Batteries should not be disposed of with normal or household waste.  
Disposal can be done via appropriate collection points in your country.

# Your automation, our passion.

## Explosion Protection

- Intrinsic Safety Barriers
- Signal Conditioners
- FieldConnex® Fieldbus Infrastructure
- Remote I/O Systems
- Electrical Explosion Protection Equipment
- Purge and Pressurization Systems
- HMI Systems
- Mobile Computing and Communications
- HART Interface Solutions
- Surge Protection
- Wireless Solutions
- Level Measurement

## Industrial Sensors

- Proximity Sensors
- Photoelectric Sensors
- Industrial Vision
- Ultrasonic Sensors
- Rotary Encoders
- Positioning Systems
- Inclination and Acceleration Sensors
- Vibration Monitoring
- Industrial Ethernet
- AS-Interface
- IO-Link
- Identification Systems
- Displays and Signal Processing
- Connectivity

[www.pepperl-fuchs.com](http://www.pepperl-fuchs.com)

Subject to modifications • © Pepperl+Fuchs  
Printed in Germany • DOCT-9141 • 01/2024 • public



**Pepperl+Fuchs Quality**

Download our latest policy here:

[www.pepperl-fuchs.com/quality](http://www.pepperl-fuchs.com/quality)