



# TEST REPORT

## FCC PART 15B

**Report Reference No.**.....: **TZ231004934-E**

Compiled by

( position+printed name+signature)...: File administrators Nancy Li

Name of the organization performing the tests

Technique principal Hugo Chen

( position+printed name+signature)...:

Approved by

( position+printed name+signature)...: Manager Andy Zhang

Date of issue.....: 13 October 2023

Representative Laboratory Name .....: Shenzhen Tongzhou Testing Co.,Ltd

Address.....: 1th Floor, Building 1, Haomai High-tech Park, Huating Road 387, Dalang Street, Longhua, Shenzhen, China



**Applicant's name**.....: **ORAIMO TECHNOLOGY LIMITED**

Address.....: FLAT N 16/F BLOCK B UNIVERSAL INDUSTRIAL CENTRE 19-25 SHAN MEI STREET FOTAN NT HONGKONG

**Test specification:**

Standard .....: **FCC Part 15B**

TRF Originator.....: Shenzhen Tongzhou Testing Co.,Ltd

Master TRF.....: Dated 2012-06

Shenzhen Tongzhou Testing Co.,Ltd All rights reserved.

This publication may be reproduced in whole or in part for non-commercial purposes as long as the Shenzhen Tongzhou Testing Co.,Ltd is acknowledged as copyright owner and source of the material. Shenzhen Tongzhou Testing Co.,Ltd takes no responsibility for and will not assume liability for damages resulting from the reader's interpretation of the reproduced material due to its placement and context.

**Test item description** ..... : Ture Wireless Earbuds

Trade Mark .....: oraimo

Model/Type reference.....: OEB-E108DC

Listed Models .....: NA

Manufacturer .....: ORAIMO TECHNOLOGY LIMITED

Power Supply.....: DC 3.85V by battery

Result.....: **Pass**

**TEST REPORT**

<b>Test Report No. :</b>	<b>TZ231004934-E</b>	签发日期 Date of issue
--------------------------	----------------------	-----------------------

Equipment under Test : Ture Wireless Earbuds

Model /Type : OEB-E108DC

Listed Models : NA

**Applicant** : **ORAIMO TECHNOLOGY LIMITED**

Address : FLAT N 16/F BLOCK B UNIVERSAL INDUSTRIAL CENTRE 19-25 SHAN MEI STREET FOTAN NT HONGKONG

**Manufacturer** : **GanzhouOuxiang Electronics Co., Ltd.**

Address : No. 66, Baokuang Road, Shangou Industrial Park, Yudu County, P.R. China

<b>Test Result</b> according to the standards on page 4:	<b>Pass</b>
--	-------------

The test report merely corresponds to the test sample.

It is not permitted to copy extracts of these test result without the written permission of the test laboratory.



## Contents

<b>1.</b>	<b><u>TEST STANDARDS .....</u></b>	<b><u>4</u></b>
<b>2.</b>	<b><u>SUMMARY .....</u></b>	<b><u>5</u></b>
2.1.	General Remarks	5
2.2.	Equipment Under Test	5
2.3.	Short description of the Equipment under Test (EUT)	5
2.4.	EUT operation mode	5
2.5.	EUT configuration	5
2.6.	Related Submittal(s) / Grant (s)	6
2.7.	Modifications	6
2.8.	Test Result Summary	6
<b>3.</b>	<b><u>TEST ENVIRONMENT .....</u></b>	<b><u>7</u></b>
3.1.	Address of the test laboratory	7
3.2.	Environmental conditions	7
3.3.	Statement of the measurement uncertainty	7
3.4.	Equipments Used during the Test	8
<b>4.</b>	<b><u>TEST CONDITIONS AND RESULTS .....</u></b>	<b><u>9</u></b>
4.1.	Radiated Emission Test	9
4.2.	Conducted Emissions Test	13
<b>5.</b>	<b><u>TEST SETUP PHOTOS OF THE EUT .....</u></b>	<b><u>16</u></b>
<b>6.</b>	<b><u>EXTERNAL AND INTERNAL PHOTOS OF THE EUT .....</u></b>	<b><u>17</u></b>



## **1. TEST STANDARDS**

The tests were performed according to following standards:

[FCC Rules Part 15 Subpart B](#)

Unintentional Radiators

[ANSI C63.4-2014](#)

American National Standard for Methods of Measurement of Radio-Noise Emissions from Low-Voltage Electrical and Electronic Equipment in the Range of 9 kHz to 40 GHz



## 2. SUMMARY

### 2.1. General Remarks

Date of receipt of test sample : 27 September 2023

Testing commenced on : 27 September 2023

Testing concluded on : 12 October 2023

### 2.2. Equipment Under Test

#### Power supply system utilised

Power supply voltage	<input checked="" type="radio"/> 120V / 60 Hz	<input type="radio"/> 230V / 50Hz
	<input type="radio"/> 12 V DC	<input type="radio"/> 24 V DC
	<input type="radio"/> Other (specified in blank below)	

DC 3.85V by battery

### 2.3. Short description of the Equipment under Test (EUT)

Ture Wireless Earbuds

For more details, refer to the user's manual of the EUT.

### 2.4. EUT operation mode

The EUT has been tested under typical operating condition.

Test Item	
EMI	
Mode 1	charge

### 2.5. EUT configuration

The following peripheral devices and interface cables were connected during the measurement:

Item t	Equipment	Mfr/Brand	Model/Type No	Series No.	Note
1	Adapter	itel	XCU32		



## 2.6. Related Submittal(s) / Grant (s)

This test report is intended for Ture Wireless Earbuds filing to comply with the FCC Part 15, Subpart B Rules.

## 2.7. Modifications

No modifications were implemented to meet testing criteria.

## 2.8. Test Result Summary

Test Item	Test Requirement	Standard Paragraph	Result
Radiated Emission	FCC PART 15	Section 15.109	PASS
Conducted Emission	FCC PART 15	Section 15.107	PASS

*Remark: The measurement uncertainty is not included in the test result.*

### **3. TEST ENVIRONMENT**

#### **3.1. Address of the test laboratory**

**Shenzhen Tongzhou Testing Co.,Ltd**  
1th Floor, Building 1, Haomai High-tech Park, Huating Road 387, Dalang Street, Longhua, Shenzhen,  
China  
The sites are constructed in conformance with the requirements of ANSI C63.7, ANSI C63.4 (2014)  
and CISPR Publication 22.

#### **3.2. Environmental conditions**

During the measurement the environmental conditions were within the listed ranges:

Temperature:	<u>15-35 ° C</u>
Humidity:	<u>30-60 %</u>
Atmospheric pressure:	<u>950-1050mbar</u>

#### **3.3. Statement of the measurement uncertainty**

The data and results referenced in this document are true and accurate. The reader is cautioned that there may be errors within the calibration limits of the equipment and facilities. The measurement uncertainty was calculated for all measurements listed in this test report acc. to CISPR 16 - 4 „Specification for radio disturbance and immunity measuring apparatus and methods – Part 4: Uncertainty in EMC Measurements“ and is documented in the Shenzhen Tongzhou Testing Co.,Ltd quality system acc. to DIN EN ISO/IEC 17025. Furthermore, component and process variability of devices similar to that tested may result in additional deviation. The manufacturer has the sole responsibility of continued compliance of the device.

Hereafter the best measurement capability for Shenzhen Tongzhou Testing Co.,Ltd is reported:

Test Item	Frequency Range	Uncertainty	Note
Radiation Uncertainty	30MHz~1000MHz	±3.92dB	(1)
	1GHz~40GHz	±4.28dB	(1)
Conduction Uncertainty	150kHz~30MHz	±2.71dB	(1)

(1). This uncertainty represents an expanded uncertainty expressed at approximately the 95% confidence level using a coverage factor of k=2.



### 3.4. Equipments Used during the Test

Conducted emission						
Item	Test Equipment	Manufacturer	Model No.	Serial No.	Last Cal.	Cal. Due
1	EMI Test Receiver	ROHDE & SCHWARZ	ESCI-7	100849/003	2022/12/28	2023/12/27
2	Artificial Mains	ROHDE & SCHWARZ	ENV 216	101333-IP	2022/12/28	2023/12/27
3	EMI Test Software	ROHDE & SCHWARZ	ESK1	V1.71	N/A	N/A

Radiated emission						
Item	Test Equipment	Manufacturer	Model No.	Serial No.	Last Cal.	Cal. Due
1	Test Receiver	R&S	ESCI-7	100849/003	2022/12/28	2023/12/27
2	wideband Antenna	Schwarzbeck	VULB 9163	958	2022/11/13	2025/11/12
3	Horn Antenna	Schwarzbeck	BBHA 9120D	01989	2022/11/13	2025/11/12
4	Amplifier	Schwarzbeck	BBV 9743	209	2022/12/28	2023/12/27
5	Amplifier	Tonscend	TSAMP-0518SE	--	2022/12/28	2023/12/27
6	Postional Controller	MF	MF7802	--	--	--
7	RE test software	Tonscend	JS32-RE	V2.0.2.0	--	--



## 4. TEST CONDITIONS AND RESULTS

### 4.1. Radiated Emission Test

#### TEST CONFIGURATION

(A) Radiated Emission Test Set-Up, Frequency below 1000MHz

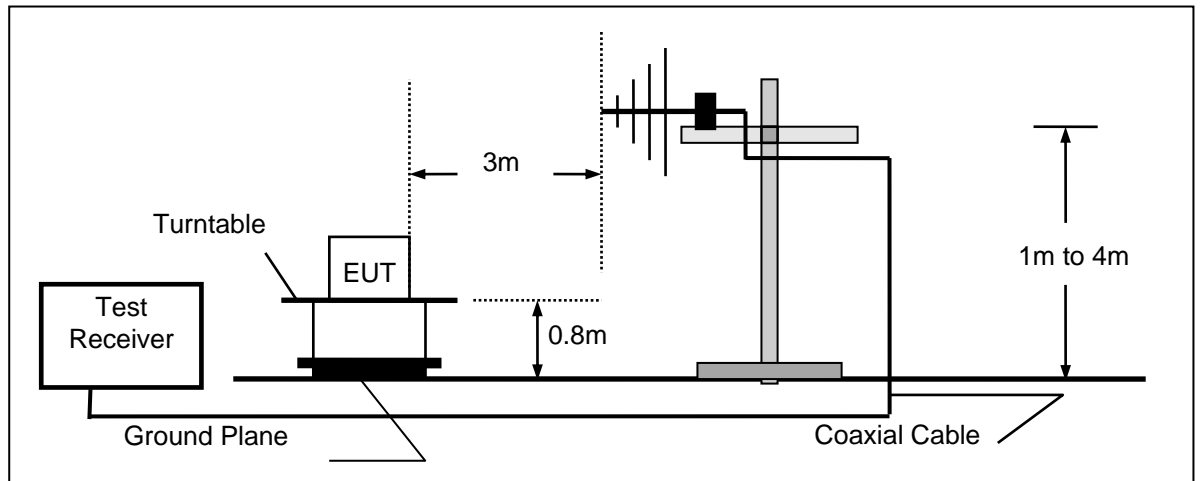

(B) Radiated Emission Test Set-Up, Frequency above 1000MHz

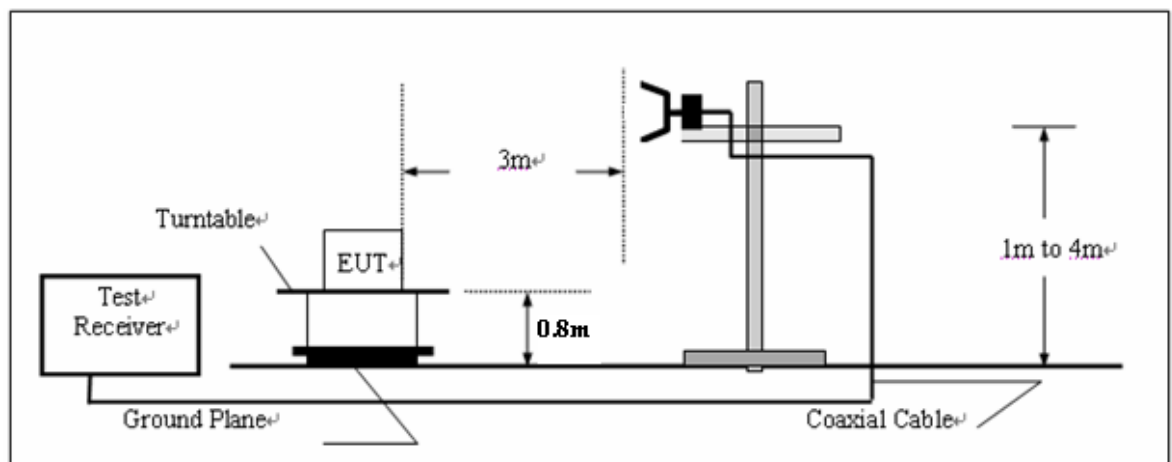



### **Field Strength Calculation**

The field strength is calculated by adding the Antenna Factor and Cable Factor and subtracting the Amplifier Gain and Duty Cycle Correction Factor(if any) from the measured reading. The basic equation with a sample calculation is as follows:

$$FS = RA + AF + CL - AG$$

Where FS = Field Strength	CL = Cable Attenuation Factor (Cable Loss)
RA = Reading Amplitude	AG = Amplifier Gain
AF = Antenna Factor	

### **RADIATION LIMIT**

For unintentional device, according to § 15.109(a), except for Class A digital devices, the field strength of radiated emissions from unintentional radiators at a distance of 3 meters shall not exceed the following values:

Frequency (MHz)	Distance (Meters)	Radiated (dBµV/m)	Radiated (µV/m)
30-88	3	40.0	100
88-216	3	43.5	150
216-960	3	46.0	200
Above 960	3	54.0	500

For intentional device, according to § 15.209(a), the general requirement of field strength of radiated emissions from intentional radiators at a distance of 3 meters shall not exceed the above table.

### **Test Procedure**

1. The EUT is placed on a turntable, which is 0.8m above ground plane.
2. The turntable shall be rotated for 360 degrees to determine the position of maximum emission level.
3. EUT is set 3m away from the receiving antenna, which is varied from 1m to 4m to find out the highest emissions.
4. Maximum procedure was performed on the six highest emissions to ensure EUT compliance.
5. And also, each emission was to be maximized by changing the polarization of receiving antenna both horizontal and vertical.
6. Repeat above procedures until the measurements for all frequencies are complete.

### **Radiation Test Results**



**Below 1000MHz((Worst Case: Mode 1)  
Polarization: Horizontal**

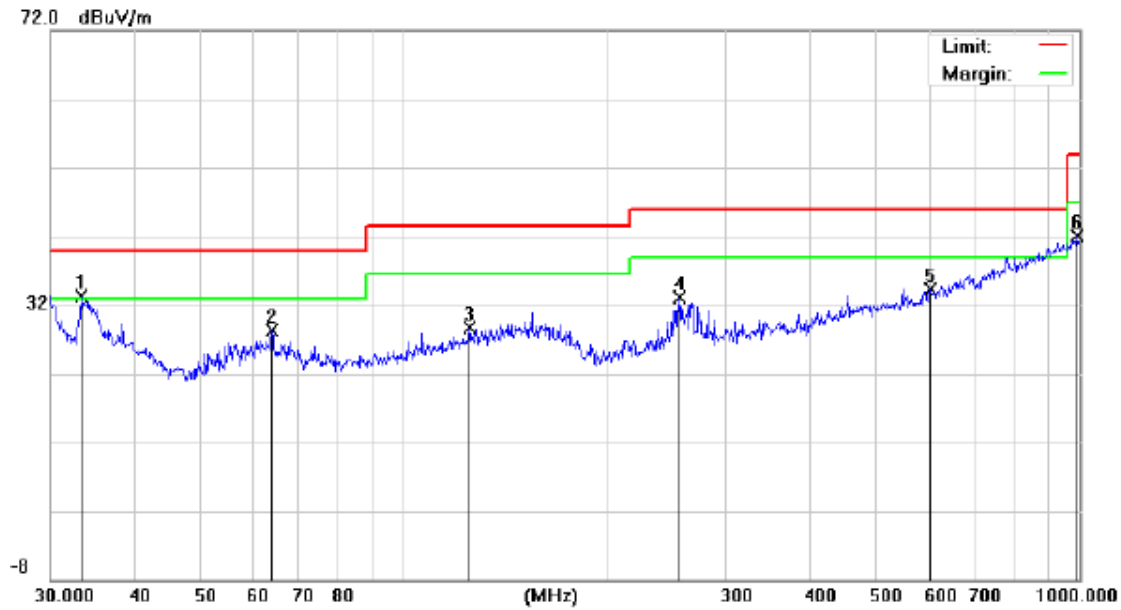

No.	Mk.	Freq. MHz	Reading Level dBuV	Correct Factor dB	Measure- ment dBuV/m	Limit dBuV/m	Over dB	Detector
1	*	33.3279	9.48	23.82	33.30	40.00	-6.70	QP
2		63.7588	5.51	22.84	28.35	40.00	-11.65	QP
3		125.0066	5.16	23.47	28.63	43.50	-14.87	QP
4		255.6231	10.47	22.69	33.16	46.00	-12.84	QP
5		601.4265	3.91	30.37	34.28	46.00	-11.72	QP
6		993.0114	5.03	37.02	42.05	54.00	-11.95	QP

**Remark:**

All emissions not reported were more than 20dB below the specified limit or in the noise floor.

Freq. = Emission frequency in MHz

Reading level (dBuV) = Receiver reading

Corr. Factor (dB) = Antenna factor + Cable loss - Amplifier factor.

Measurement (dBuV/m) = Reading level (dBuV) + Corr. Factor (dB)

Over (dB) = Measurement (dBuV/m) – Limit(dBuV/m)

All the x/y/z orientation has been investigated, and only worst case is presented in this report(Charge mode).



**Polarization: Vertical**

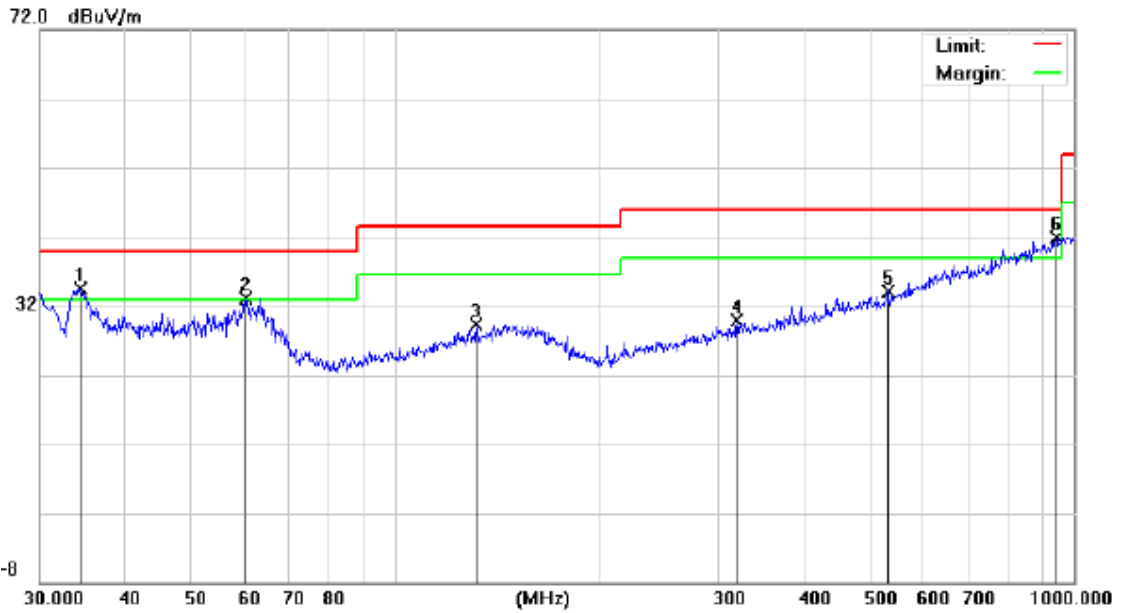

No.	Mk.	Freq. MHz	Reading Level dBuV	Correct Factor dB	Measure- ment dBuV/m	Limit dBuV/m	Over dB	Detector
1	!	34.3963	10.45	23.97	34.42	40.00	-5.58	QP
2	!	60.2800	9.75	23.42	33.17	40.00	-6.83	QP
3		131.7576	5.61	23.74	29.35	43.50	-14.15	QP
4		318.8170	5.26	24.55	29.81	46.00	-16.19	QP
5		531.9634	5.54	28.54	34.08	46.00	-11.92	QP
6	*	942.1304	5.68	36.25	41.93	46.00	-4.07	QP

**Remark:**

All emissions not reported were more than 20dB below the specified limit or in the noise floor.

Freq. = Emission frequency in MHz

Reading level (dBuV) = Receiver reading

Corr. Factor (dB) = Antenna factor + Cable loss - Amplifier factor.

Measurement (dBuV/m) = Reading level (dBuV) + Corr. Factor (dB)

Over (dB) = Measurement (dBuV/m) – Limit(dBuV/m)

All the x/y/z orientation has been investigated, and only worst case is presented in this report(Charge mode).

**Above 1000MHz(Worst Case: Mode 1)**

Freq. (MHz)	Ant. Pol. H/V	Emission Level(dBuV/m)		Limit 3m(dBuV/m)		Over(dB)	
		PK	AV	PK	AV	PK	AV
1539.44	V	60.54	41.00	74	54	-13.46	-13.00
2388.16	V	58.09	40.48	74	54	-15.91	-13.52
1643.39	H	58.92	39.64	74	54	-15.08	-14.36
2176.27	H	59.17	40.17	74	54	-14.83	-13.83

**Remark:**

All emissions not reported were more than 20dB below the specified limit or in the noise floor.

Freq. = Emission frequency in MHz

Factor = Antenna Factor + Cable Loss – Pre-amplifier.

Over= Emission Level - Limit.

All the x/y/z orientation has been investigated, and only worst case is presented in this report.

## 4.2. Conducted Emissions Test

### TEST CONFIGURATION

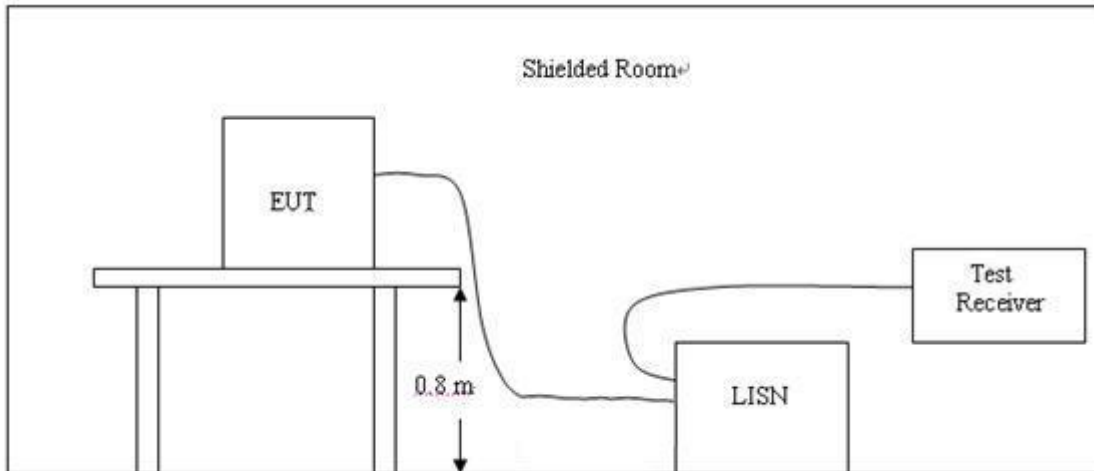

### TEST PROCEDURE

- 1 The equipment was set up as per the test configuration to simulate typical actual usage per the user's manual. The EUT is a tabletop system, a wooden table with a height of 0.8 meters is used and is placed on the ground plane as per ANSI C63.4.
- 2 Support equipment, if needed, was placed as per ANSI C63.4.
- 3 All I/O cables were positioned to simulate typical actual usage as per ANSI C63.4.
- 4 The EUT received power through a Line Impedance Stabilization Network (LISN) which supplied power source and was grounded to the ground plane.
- 5 All support equipments received AC power from a second LISN, if any.
- 6 The EUT test program was started. Emissions were measured on each current carrying line of the EUT using a spectrum Analyzer / Receiver connected to the LISN powering the EUT. The LISN has two monitoring points: Line 1 (Hot Side) and Line 2 (Neutral Side). Two scans were taken: one with Line 1 connected to Analyzer / Receiver and Line 2 connected to a 50 ohm load; the second scan had Line 1 connected to a 50 ohm load and Line 2 connected to the Analyzer / Receiver.
- 7 Analyzer / Receiver scanned from 150 KHz to 30MHz for emissions in each of the test modes.
- 8 During the above scans, the emissions were maximized by cable manipulation.

### Conducted Power Line Emission Limit

For unintentional device, according to § 15.107(a) Line Conducted Emission Limits is as following :

Frequency (MHz)	Maximum RF Line Voltage (dBµV)			
	CLASS A		CLASS B	
	Q.P.	Ave.	Q.P.	Ave.
0.15 - 0.50	79	66	66-56*	56-46*
0.50 - 5.00	73	60	56	46
5.00 - 30.0	73	60	60	50

\* Decreasing linearly with the logarithm of the frequency

For intentional device, according to §15.207(a) Line Conducted Emission Limit is same as above table.



**TEST RESULTS**

Temperature	20 °C	Relative Humidity	48%
Pressure	1010 hPa	Test Mode	Mode 1(the worst case)

Conducted Emission on Line Terminal of the power line (150 kHz to 30MHz)

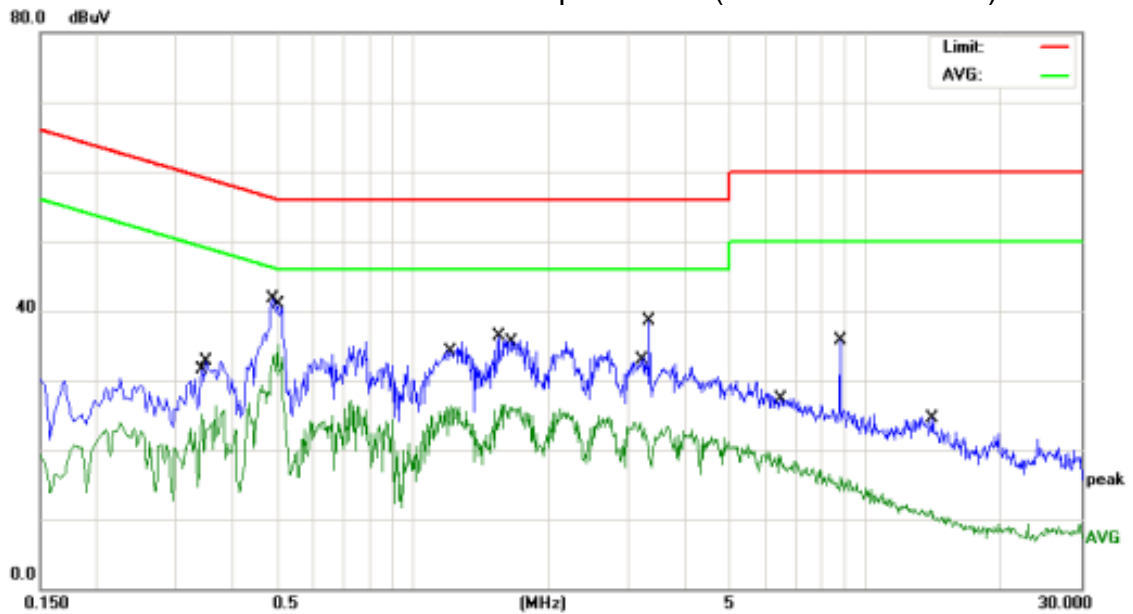

No.	Mk.	Freq. MHz	Reading Level dBuV	Correct Factor dB	Measure- ment dBuV	Limit dBuV	Over dB	Detector
1		0.3420	14.61	10.48	25.09	49.15	-24.06	AVG
2		0.3500	22.21	10.48	32.69	58.96	-26.27	QP
3		0.4900	31.25	10.52	41.77	56.17	-14.40	QP
4	*	0.5020	24.50	10.52	35.02	46.00	-10.98	AVG
5		1.2140	15.75	10.58	26.33	46.00	-19.67	AVG
6		1.5460	25.62	10.64	36.26	56.00	-19.74	QP
7		1.6500	15.48	10.65	26.13	46.00	-19.87	AVG
8		3.1740	13.11	10.72	23.83	46.00	-22.17	AVG
9		3.3300	27.82	10.72	38.54	56.00	-17.46	QP
10		6.4620	8.61	10.77	19.38	50.00	-30.62	AVG
11		8.8220	24.96	10.81	35.77	60.00	-24.23	QP
12		14.0780	13.43	11.13	24.56	60.00	-35.44	QP

Conducted Emission on Neutral Terminal of the power line (150 kHz to 30MHz)

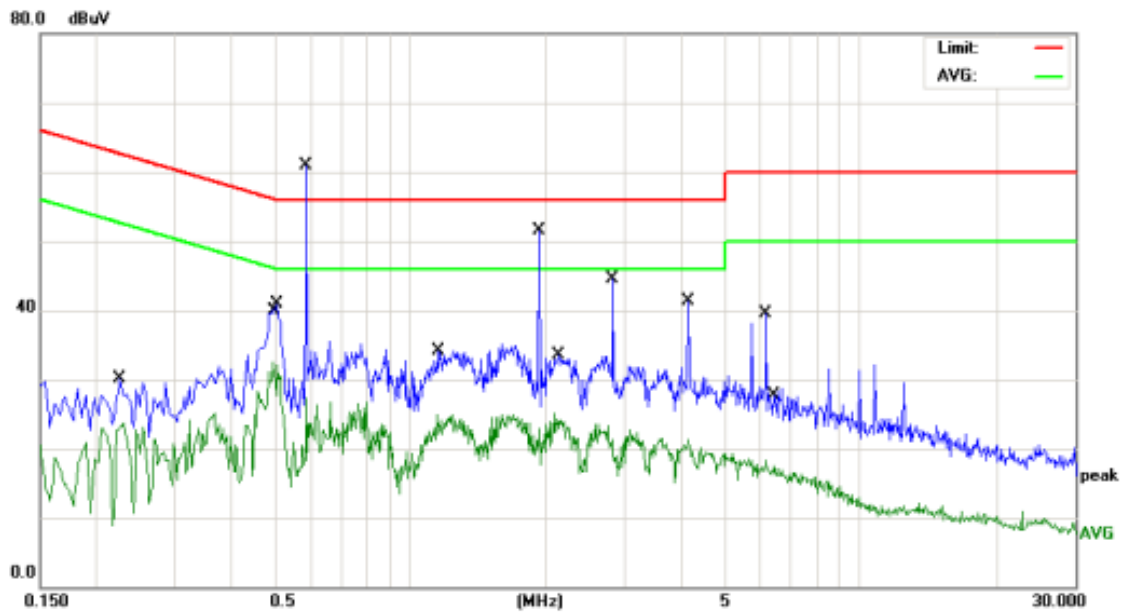

No.	Mk.	Freq. MHz	Reading Level dBuV	Correct Factor dB	Measurement dBuV	Limit dBuV	Over dB	Detector
1		0.2260	19.69	10.46	30.15	62.59	-32.44	QP
2		0.2268	12.78	10.46	23.24	52.56	-29.32	AVG
3		0.4940	21.89	10.52	32.41	46.10	-13.69	AVG
4		0.5060	30.45	10.52	40.97	56.00	-15.03	QP
5		0.5860	14.83	10.52	25.35	56.00	-30.65	QP
6		1.1420	14.31	10.57	24.88	46.00	-21.12	AVG
7	*	1.9380	40.85	10.70	51.55	56.00	-4.45	QP
8		2.1660	13.41	10.71	24.12	46.00	-21.88	AVG
9		2.8179	33.74	10.72	44.46	56.00	-11.54	QP
10		4.1500	10.64	10.73	21.37	46.00	-24.63	AVG
11		6.1660	28.83	10.76	39.59	60.00	-20.41	QP
12		6.4420	6.82	10.77	17.59	50.00	-32.41	AVG

Remark:

Freq. = Emission frequency in MHz

Reading level (dBuV) = Receiver reading

Corr. Factor (dB) = Antenna factor + Cable loss - Amplifier factor.

Measurement (dBuV/m) = Reading level (dBuV) + Corr. Factor (dB)

Over (dB) = Measurement (dBuV/m) – Limit(dBuV/m)



## **5. Test Setup Photos of the EUT**

Please refer to separated files for Test Setup Photos of the EUT.





## **6. External and Internal Photos of the EUT**

### **External Photos**

*Please refer to the attachment 'Annex OEB-E108DC External Photo' for external photos*

### **Internal Photos**

*Please refer to the attachment 'Annex OEB-E108DC Internal Photo' for internal photos*

**.....End of Report.....**