

ANYCUBIC PHOTON M3 PREMIUM

User Manual

Dear customer,

Thank you for choosing **ANYCUBIC** products.

Maybe you are familiar with 3D printing technology or have purchased **ANYCUBIC** printers before, we still highly recommend that you read this manual carefully. The installation techniques and precautions in this manual can help you avoid any unnecessary damage or frustration.

Please visit <https://support.anycubic.com> to contact us if you have any question. You can also gain more information such as software, videos, models from the website.



ANYCUBIC support center

Team **ANYCUBIC**

Copyrighted by "Shenzhen Anycubic Technology Co., Ltd ", all rights reserved.

Safety Instructions

Always follow the safety instructions during assembly and usage, to avoid unnecessary damage to the 3D printer or individual injury



Please contact our customer service first if you have any issue after receiving the products.



Be cautious when using the scraper. Never direct the scraper towards your hands.



In case of emergency, please immediately cut off the power of Anycubic 3D printer and contact the technical support.



Anycubic 3D printer includes moving parts that can cause injury.



It is recommended to use protective glasses when sanding the printed models to avoid eye contact with small particles.



Keep the Anycubic 3D printer and its accessories out of the reach of children.



Vapors or fumes may be irritating at operating temperature. Always use the Anycubic 3D printer in an open and well ventilated area.



Anycubic 3D printer must not be exposed to water or rain.



Operate Anycubic 3D printer with a temperature of 8°C-40°C and a humidity of 20%-50%. For optimal performance, do not exceed this range. Also, avoid direct sunlight exposure.



Do not disassemble Anycubic 3D printer, please contact technical support if you have any question.



Contents

1. Product Overview	5
2. In the Box	6
3. Technical Specification	7
4. Recommended Print Parameters	8
5. Menu Directory	10
6. Preparations	13
7. Print Test	16
8. Resin Exposure Range Finder	18
9. FAQ	20
10. Machine Maintenance	21

Product Overview

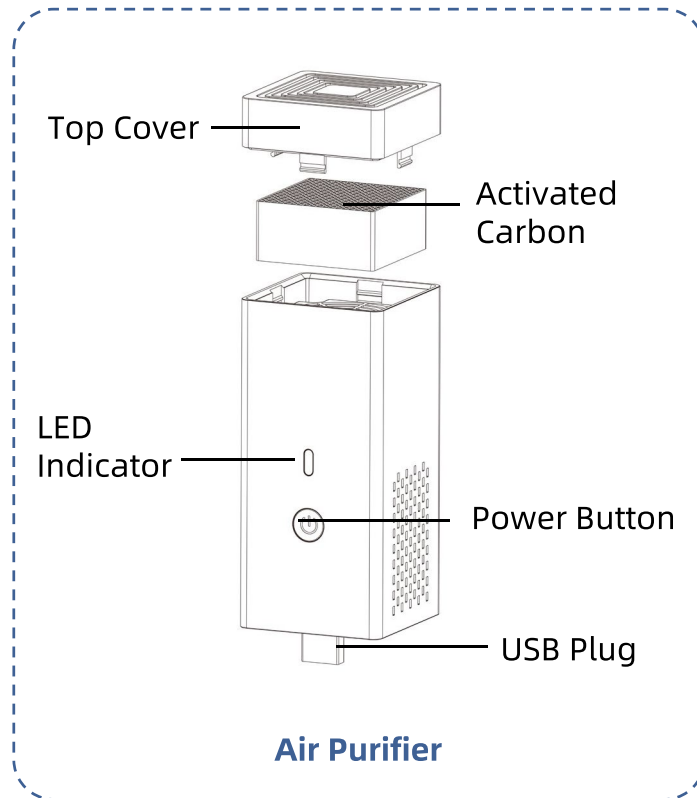
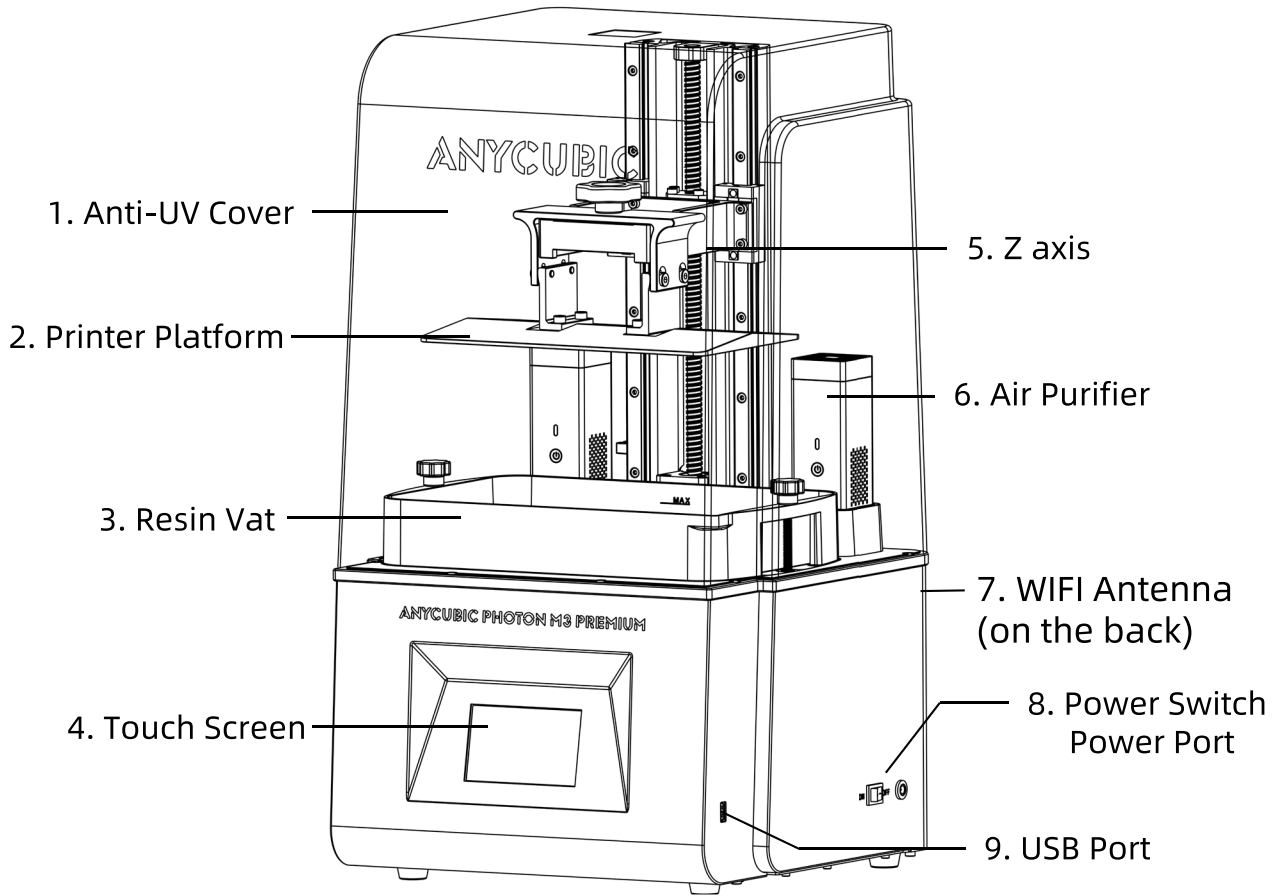

In the Box

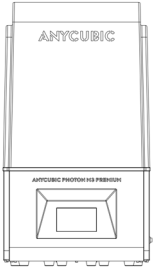

Anycubic Photon
M3 Premium



Air Purifier * 2

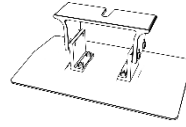

Print platform * 1



Resin vat * 1

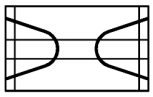

Mask * 1



Gloves* 3 Pairs

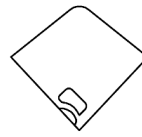

Funnel*5

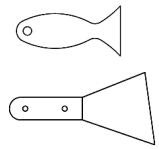

Scraper * 2



USB drive * 1



Manual * 1



Screen Protector Kit



Leveling paper * 1



Power Adaptor
Power Cord



WIFI Antenna*



Wench Kit

*Anycubic Photon M3 Premium will be added to Anycubic Cloud soon, please properly keep the WIFI antenna.

Technical Specification

Printing

System	Anycubic Photon M3 Premium
Operation	4.3-inch Color TFT Screen
Software	Anycubic Photon Workshop
Connectivity	USB Drive

Specifications

Light source	Anycubic Light Turbo 2.0
XY Resolution	28.5 μm 7680*4320 (8K)
Z axis Accuracy	0.01 mm
Suggested Layer Thickness	0.01 ~ 0.1mm
Rated power	110 W

Physical Dimensions

Dimension	328 mm (L) *350 mm (W) *626 mm (H)
Build volume	219 mm (L) *123 mm (W) *250 mm (H)
Net weight	~19 kg

Air Purifier

Rated input	5V 0.1A
-------------	---------

Recommended Print Parameters

Basic Mode Parameter

1、 Basic Resin-Clear/Translucent Green

Requirement of model	Normal					High-accuracy
Layer Thickness (mm)	0.01~0.02	0.03~0.04	0.05	0.1	0.15	0.05
Normal Exposure Time (s)	1.2	1.5	2	3	4	1.7
Off Time (s)	0.5					
Bottom Exposure Time (s)	25					
Bottom Layers	2					
Anti-alias	1					
Z Lift Distance (mm)	8					
Z Lift Speed (mm/s)	4					2
Z Retract Speed (mm/s)	6					3

2、 Basic Resin-Gray, DLP Craftsman Resin-Beige/Apricot

Requirement of model	Normal					High-accuracy
Layer Thickness (mm)	0.01~0.02	0.03~0.04	0.05	0.1	0.15	0.05
Normal Exposure Time (s)	1.7	2	2.5	3.5	4.5	2
Off Time (s)	0.5					
Bottom Exposure Time (s)	25					
Bottom Layers	2					
Anti-alias	1					
Z Lift Distance (mm)	8					
Z Lift Speed (mm/s)	4					2
Z Retract Speed (mm/s)	6					3

The data above root in Anycubic lab, only for reference.

Recommended Print Parameters

Advance Mode Parameter*

Layer Thickness (mm)	0.15
Normal Exposure Time (s)	3.5
Off Time (s)	0.1
Bottom Exposure Time (s)	25
Bottom Layers	1
Anti-alias	1

Bottom Layers

Step [0]	Z Lift Distance (mm)	2
	Z Lift Speed (mm/s)	6
	Z Retract Speed (mm/s)	6
Step [1]	Z Lift Distance (mm)	2
	Z Lift Speed (mm/s)	6
	Z Retract Speed (mm/s)	6

Transition Layer Count: 1

Normal Layers

Step [0]	Z Lift Distance (mm)	2
	Z Lift Speed (mm/s)	6
	Z Retract Speed (mm/s)	6
Step [1]	Z Lift Distance (mm)	2
	Z Lift Speed (mm/s)	6
	Z Retract Speed (mm/s)	6

*The parameter is suitable for Basic Resin-Clear/Translucent Green.

The data above root in Anycubic lab, only for reference.

Menu Directory

Home menu

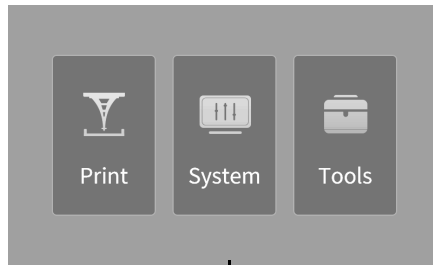

Print

System

Tools

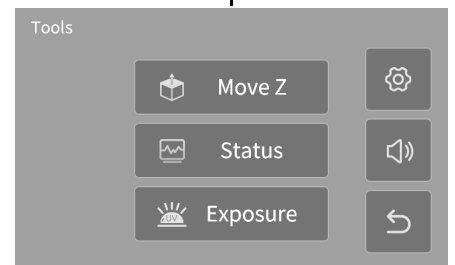
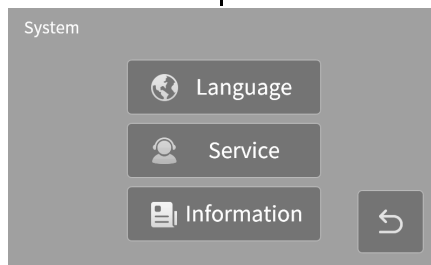
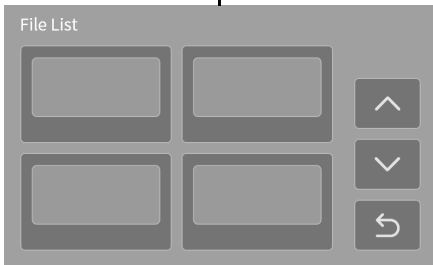

Print

File List:



Page up

Page down

Return to the Home Menu

File

Click a file



Delete the current file

Click to start printing

Return to the Print Menu

System

Language:



Service:



Information:

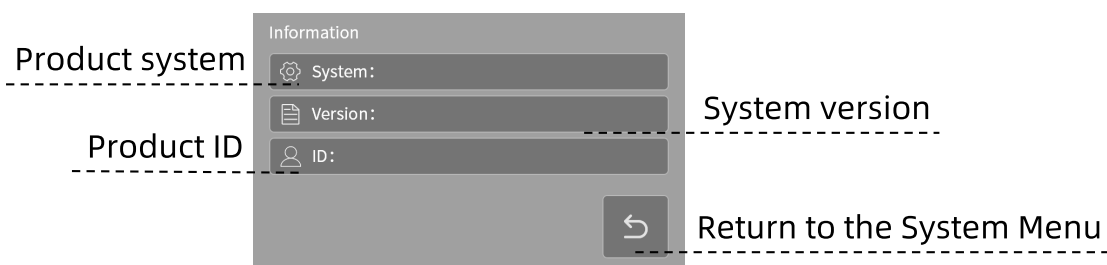

Tools

Move Z:

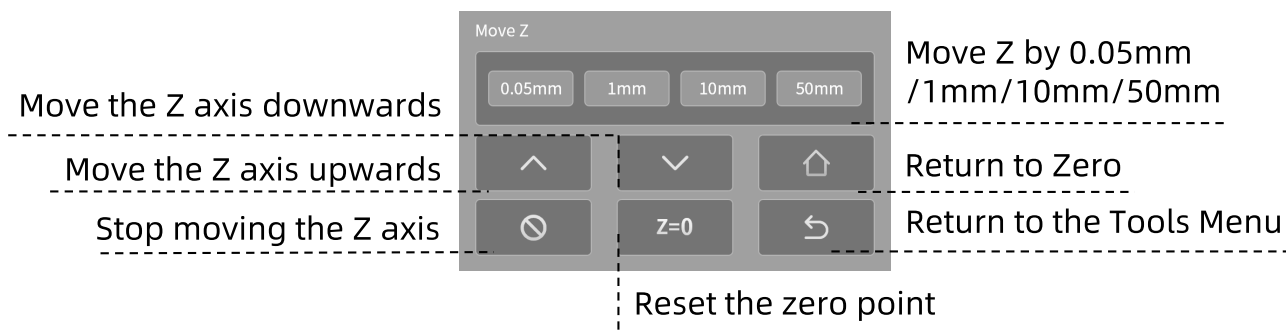

Exposure :

Choose an image to expose

Click to set the time

Expose for the preset time

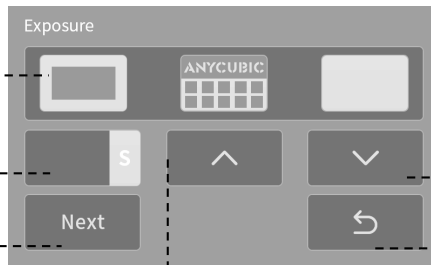

Reduce the test time

Return to the Tools Menu

Increase the test time

Status:

Statistics of print times

Whether release film
needs to be replaced

Temperature of the UV-LED

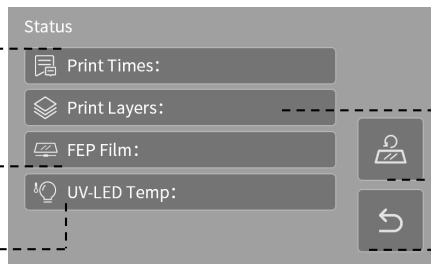

Statistics of print layers

Click to reset the status

Return to Tools Menu

Gear icon: Enter to switch on/off air purifier

Horn icon: Turn on/off the screen sound

Preparations

1. Plug in power and turn on the machine. Raise Z axis by 50mm.

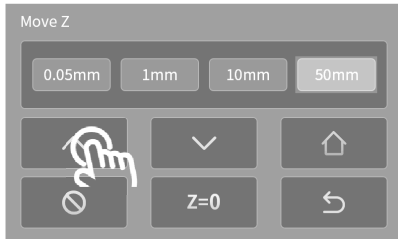
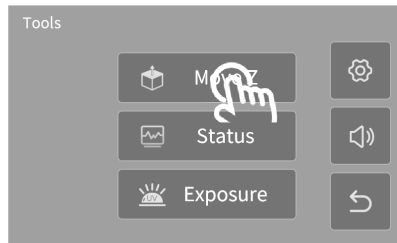
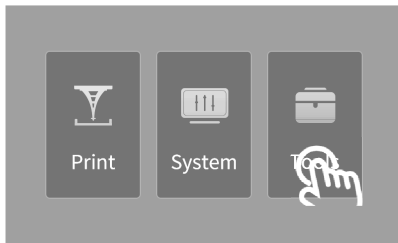

2. Install print platform.

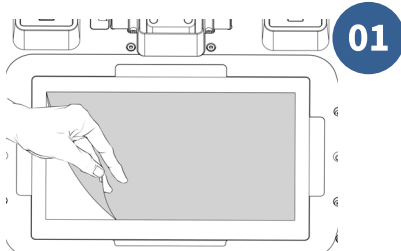

Tear off the protective film

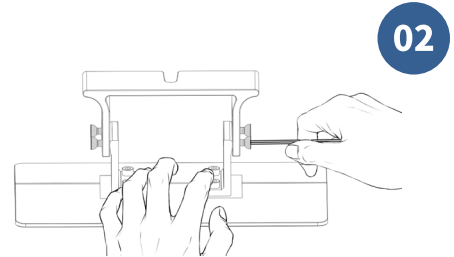

Loosen the four screws
on the platform

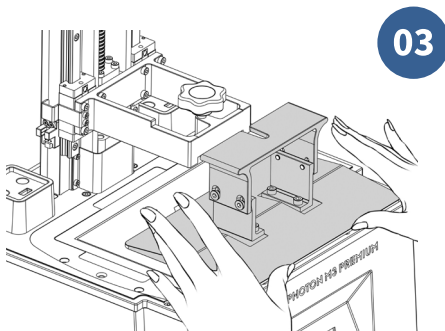

Push the platform onto the
platform carrier

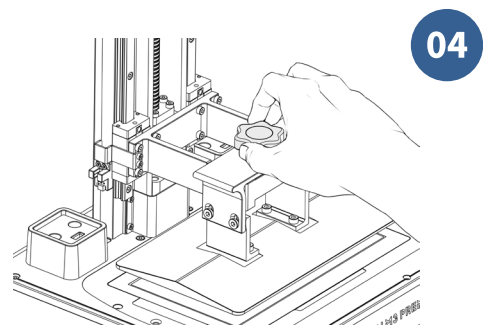

Tighten the knob

Preparations

4. Leveling.

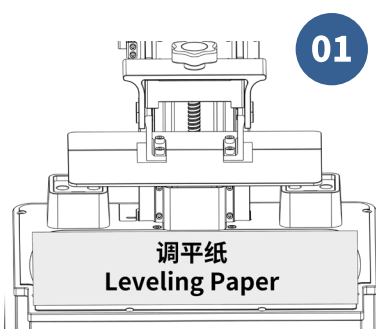

Place the leveling paper on the curing screen



Click "HOME"

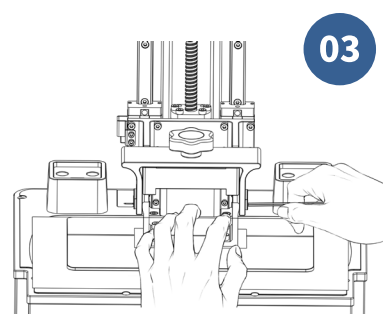

Press the platform gently, tighten the four screws

5. Set the zero position.

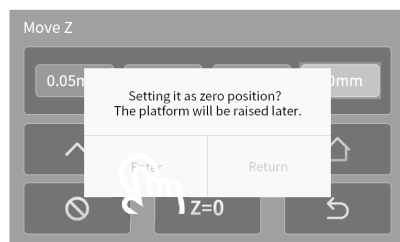
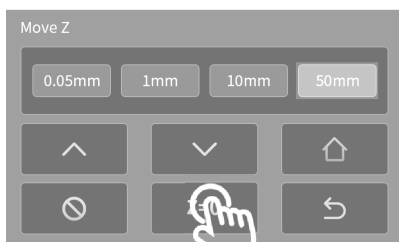

6. Choose an exposure image to test after the platform stops moving.

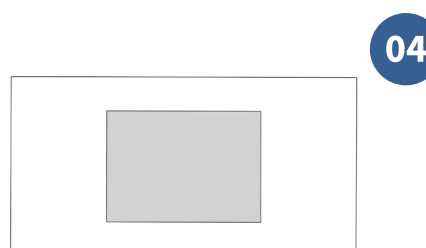
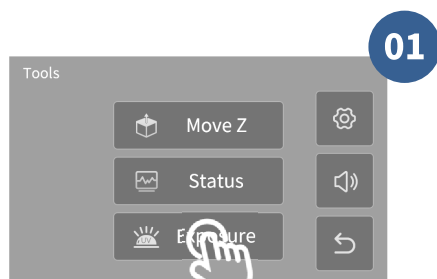

The white part is exposure area

Preparations

7. Install the resin vat.

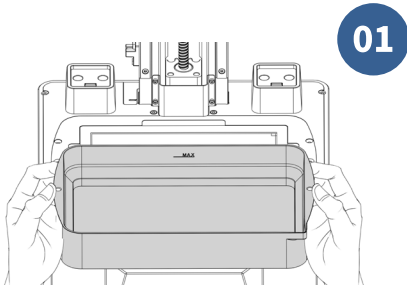

Push in the resin vat

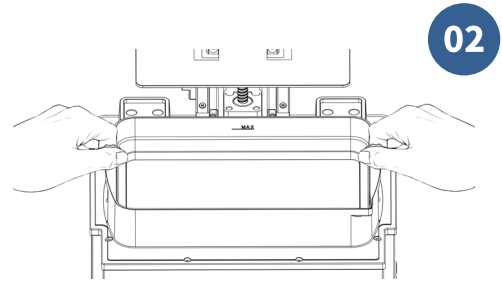

Tighten two knobs

8. Install two air purifiers.



Open the top cover and then
remove the protective package

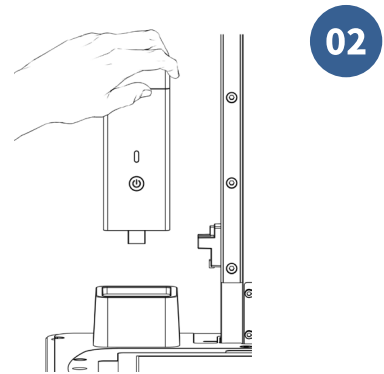

Insert the air purifier onto the base

Print Test

***Please check FEP film carefully before and after every printing. If the FEP film is broken, replace it immediately to avoid further damage to machine.**

1. Make sure you wear masks and gloves (to avoid direct skin contact with resin), slowly pour resin into the vat with **resin level not exceeding the vat's maximum scale.**

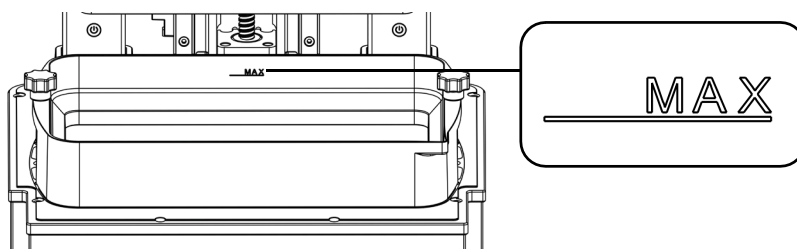

2. Press the power button of air purifier to turn on it. The green light shows that it works normally.

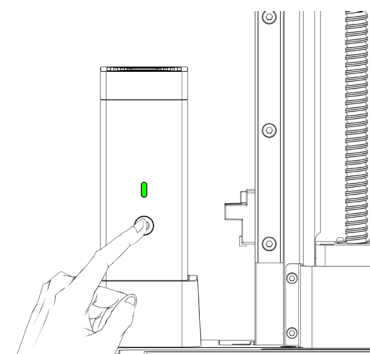

3. Put on the anti-UV cover. Then, insert the USB drive and print the test file.

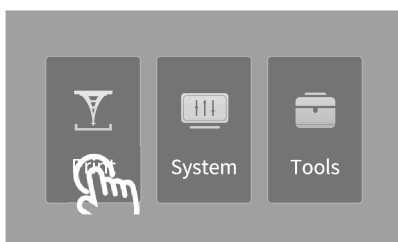

Notes:

- ① It is recommended that use the USB drive we provided. Otherwise, please use the USB drive whose memory size **not exceed 8G** and ensure that it is formatted to **FAT/FAT 32**.
- ② The print files should be placed at the root directory of USB drive to avoid read error.

Finishing

- After printing, remove the platform when resin stop dropping from the platform. Remove model by metal scraper and then wash model with 95% alcohol or other detergent. The printed model may need post curing to achieve better hardness by direct sunlight or UV-curing machine.

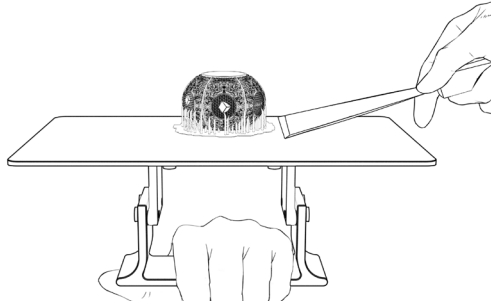

- After printing, there might be some cured resin left in the vat. Please clean the vat timely, and filter the remaining resin by a funnel. Otherwise, it may cause damage to release film or LCD screen. If you do not use the resin now, it is recommended to store resin in an airtight container which is away from light.

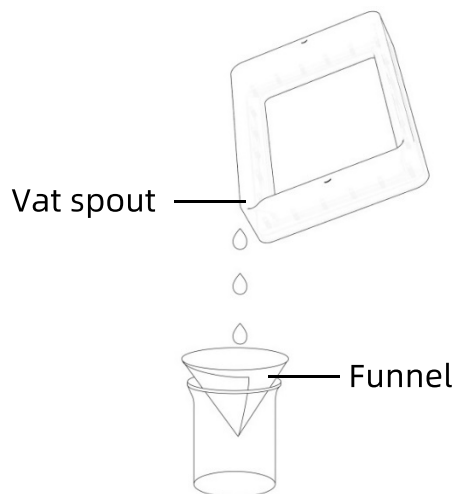

Resin Exposure Range Finder

“R_E_R_F” is an abbreviation for “Resin Exposure Range Finder”. This function is used to find out the optimal exposure parameters for different resins.

1. Import the R_E_R_F file which has been saved into USB drive into the slicing software. There are eight models in the file. The exposure time for model 1 is equal to "normal exposure time (s)" of the file, and the exposure time for other models will be increased by an increment of **0.25 s**.

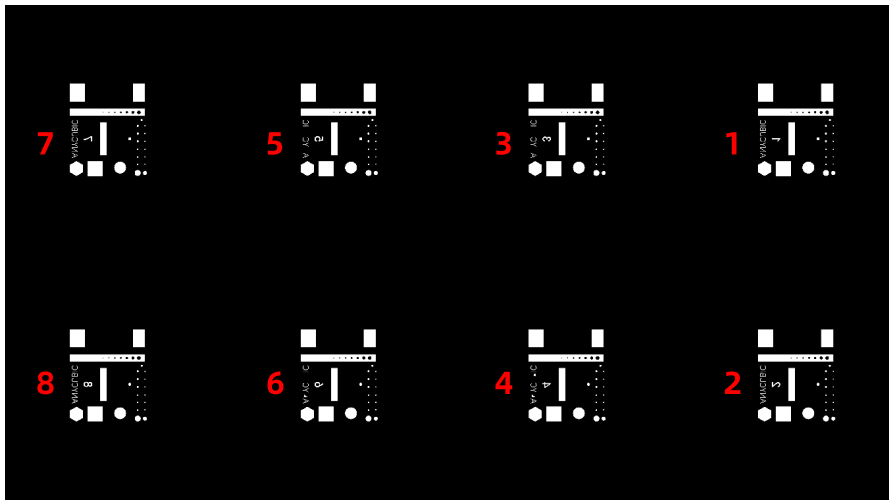

The numbers on the models
indicate their order

2. According to the personal requirement, adjust the exposure time of the models by modifying "normal exposure time (s)" of the file. When exposure time for Model No. 1 is changed, exposure time for other models will be increased by an increment of **0.25 s**.

For example, when normal exposure time is set to 1.5 s, the exposure time for Model No.1-8 is: 1.5 / 1.75 / 2 / 2.25 / 2.5 / 2.75 / 3 / 3.25 s.

3. After printing, remove and clean the models. Compare the print effect of models and choose exposure time of the model that meet your needs as the print parameter. Take Comparison of model A&B as an example.

Resin Exposure Range Finder

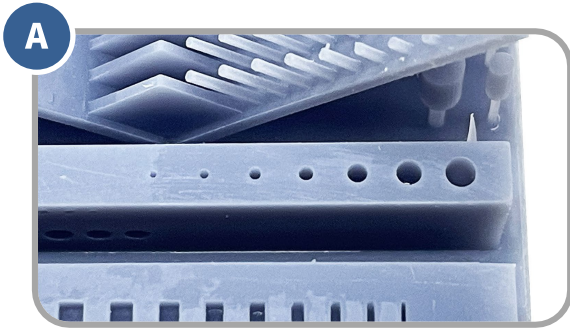

More holes

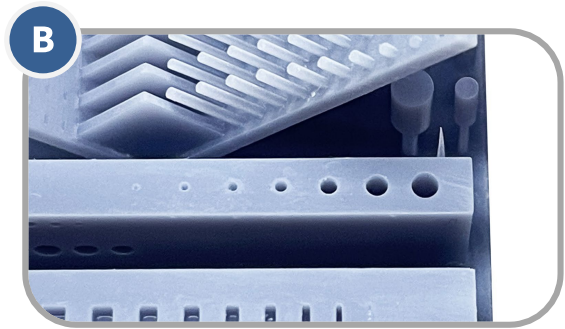

Less holes

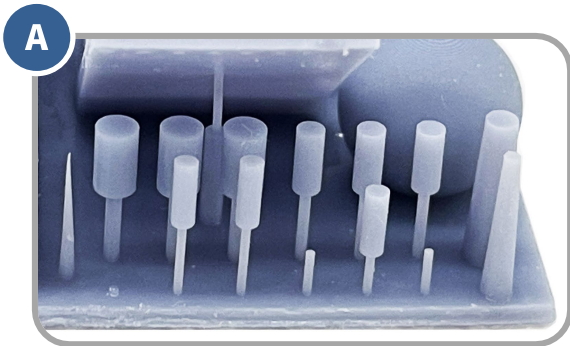

Less cylinder

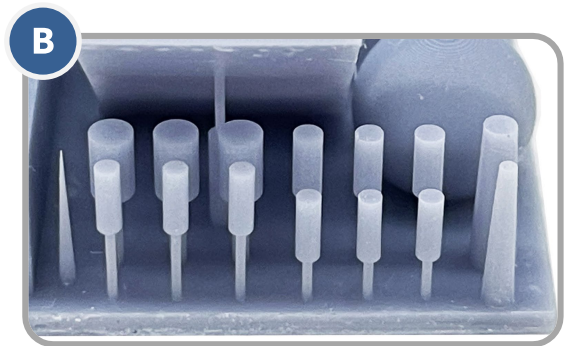

More cylinder

- Model A has more holes and less cylinder. If you print by the parameter of model A, more details of the model can be printed with high risk of failure.
- Model B has less holes and more cylinder. If you print by the parameter of model B, the model may be print successfully with some details lost.

In addition, you can compare the bridges, needles or other parts to choose a proper model and find the parameter. If none of them can be chose, it is suggested to adjust the "normal exposure time (s)" .

Notice: DO NOT change the file name of "R_E_R_F" , because Anycubic 3D printer can only recognize THIS file name to run this function. Also, do not name other file as "R_E_R_F" .

Model do not stick to platform

- Bottom exposure time is insufficient, increase the exposure time.
- Contact area between the model and platform is small, please add raft.
- Bad leveling.

Layer separation or splitting

- The machine is not stable during printing.
- FEP film in the vat is not tight enough or it need a change for new one.
- The printing platform or resin vat is not tightened.
- The lift speed is too fast.
- The printing object is hollowed without punching.

Layer shift

- Add supports.
- Reduce the lift speed.

Floccules left in resin vat or attached to models

- The exposure time is too long. Reduce the normal exposure time and bottom exposure time.

Resin vat maintenance

- **Remove the cured resin from release film:** Set full-screen exposure for 20s and then remove the cured resin sheet to protect the film. Do not use sharp objects to scrape off the residues on FEP film.



- **Release film replacement:** The statistics of print times and print layers are shown in Status interface. Please check them and replace release film timely to avoid print failure or even the damage to printer.

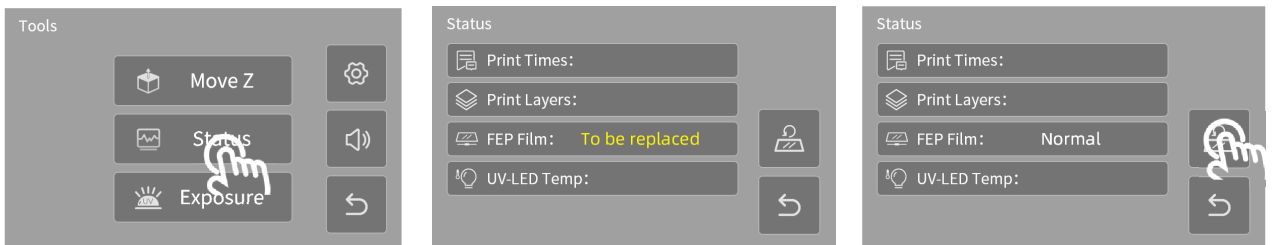

Replace release film
at this time

Click reset button
after replacement

- If you do not use the resin for over two days, store it in an airtight container that it is away from light.

Z axis maintenance

If Z axis make noisy sound, please apply lubricant to Z lead screw.

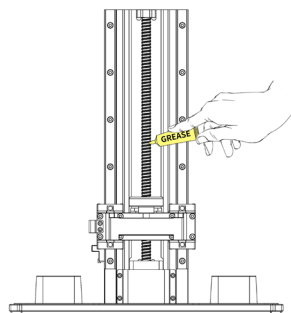

Cleaning

- **Clean the print platform:** Clean platform with alcohol and paper towel.
- **Protect LCD screen :** If there are resin cured on screen protector, please replace it immediately to protect LCD screen.
- **Clean the body of printer:** Clean the body of printer with alcohol.

Air Purifier

It is recommended to replace the activated carbon every 3-6 months for optimal performance.

FCC WARNING

This device complies with part 15 of the FCC Rules. Operation is subject to the following two conditions: (1) this device may not cause harmful interference, and (2) this device must accept any interference received, including interference that may cause undesired operation.

Any changes or modifications not expressly approved by the party responsible for compliance could void the user's authority to operate the equipment.

NOTE: This equipment has been tested and found to comply with the limits for a Class B digital device, pursuant to Part 15 of the FCC Rules. These limits are designed to provide reasonable protection against harmful interference in a residential installation. This equipment generates, uses and can radiate radio frequency energy and, if not installed and used in accordance with the instructions, may cause harmful interference to radio communications. However, there is no guarantee that interference will not occur in a particular installation.

If this equipment does cause harmful interference to radio or television reception, which can be determined by turning the equipment off and on, the user is encouraged to try to correct the interference by one or more of the following measures:

- Reorient or relocate the receiving antenna.
- Increase the separation between the equipment and receiver.
- Connect the equipment into an outlet on a circuit different from that to which the receiver is connected.
- Consult the dealer or an experienced radio/TV technician for help.

To maintain compliance with FCC's RF Exposure guidelines, This equipment should be installed and operated with minimum distance between 20cm the radiator your body: Use only the supplied antenna.

Thank you for purchasing Anycubic products! Under normal usage and service, the products have a warranty period up to one year. Please visit Anycubic support center(support.anycubic.com/en) to report any issue with Anycubic products. Our professional after-sale service team would respond within 24 hours and solve the issues.