

10.6.4.2.2.2 Uplink

Test link	Frequency (MHz)	EUT Max. output power (dBm)	Max. Ant Gain(dBi)	ERP (W)	ERP Limit (W)	AGC Mode
1. P25 Phase I(C4FM)						
Up	806.00625	27.0	9.0	4.0	5.0	-0.5dB Below
Up	806.00625	27.0	9.0	4.0	5.0	+3.0dB above
Up	811.0	26.5	9.0	3.5	5.0	-0.5dB Below
Up	811.0	26.5	9.0	3.5	5.0	+3.0dB above
Up	815.99375	26.0	9.0	3.2	5.0	-0.5dB Below
Up	815.99375	26.0	9.0	3.2	5.0	+3.0dB above
2. P25 Phase II(H-DQPSK)						
Up	806.00625	26.9	9.0	3.9	5.0	-0.5dB Below
Up	806.00625	26.9	9.0	3.9	5.0	+3.0dB above
Up	811.0	27.0	9.0	4.0	5.0	-0.5dB Below
Up	811.0	27.0	9.0	4.0	5.0	+3.0dB above
Up	815.99375	26.0	9.0	3.2	5.0	-0.5dB Below
Up	815.99375	26.0	9.0	3.2	5.0	+3.0dB above
3. Analog FM						
Up	806.0125	26.8	9.0	3.8	5.0	-0.5dB Below
Up	806.0125	26.8	9.0	3.8	5.0	+3.0dB above
Up	811.0	26.3	9.0	3.4	5.0	-0.5dB Below
Up	811.0	26.4	9.0	3.5	5.0	+3.0dB above
Up	815.9875	26.0	9.0	3.2	5.0	-0.5dB Below
Up	815.9875	26.0	9.0	3.2	5.0	+3.0dB above
4. Tetra						
Up	806.0125	27.0	9.0	4.0	5.0	-0.5dB Below
Up	806.0125	27.0	9.0	4.0	5.0	+3.0dB above
Up	811.0	26.6	9.0	3.6	5.0	-0.5dB Below
Up	811.0	26.7	9.0	3.7	5.0	+3.0dB above
Up	815.9875	26.2	9.0	3.3	5.0	-0.5dB Below
Up	815.9875	26.3	9.0	3.4	5.0	+3.0dB above

10.7 Noise figure

Test requirement: KDB 935210 D05 clause 4.6
 FCC PART 90.219 (e)(2)
 Test Method: KDB 935210 D05/4.6

10.7.1 Requirements

According to FCC PART 90 § 90.219 (e) (2) requirement, the noise figure limit of a signal booster must be given in table 10.7-1 in either direction.

Table 10.7-1 Noise figure limits

frequency range(MHz)	Max. Noise figure limit(dB)
758-775/788~805	9
851-861/806-816	9

10.7.2 Test configuration

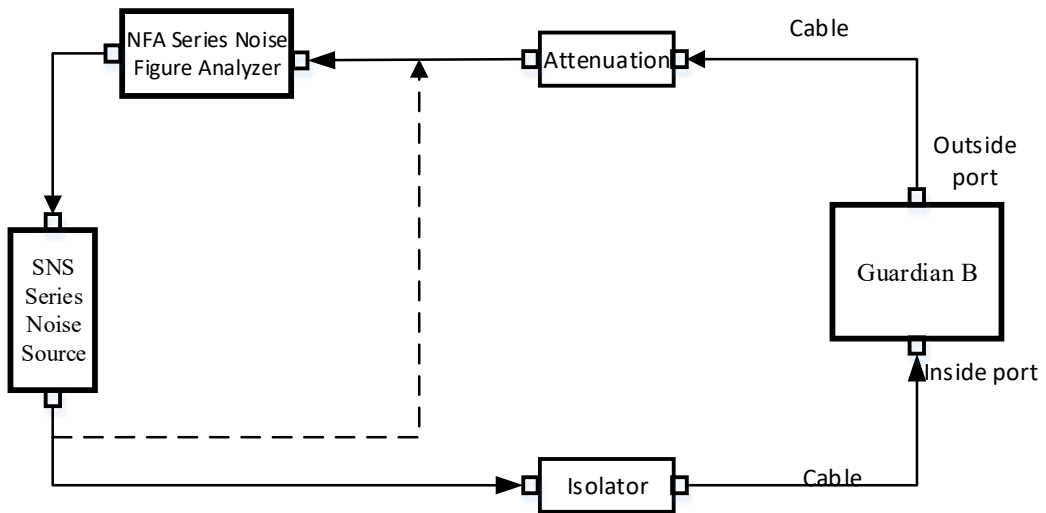

Figure 10.7-1 Downlink connection diagram

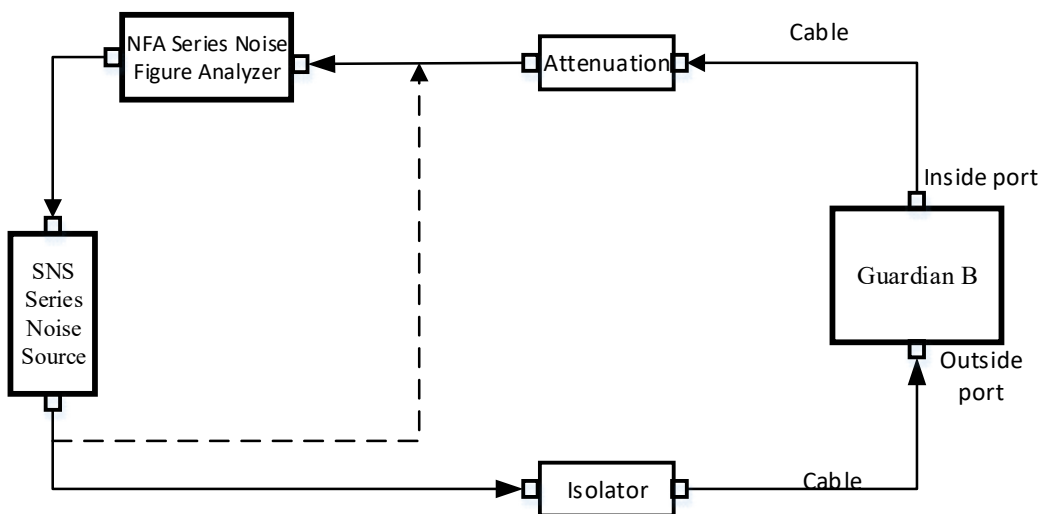

Figure 10.7-2 Uplink connection diagram

10.7.3 Test procedures

- (1) Connect the device as illustrated Figure, when the output power is over the maximum value of the Noise meter, add the attenuator to avoid destroying;
- (2) Set the EUT operating band and maximum gain;
- (3) Set the relevant parameters for 700MHz of device and connect the dotted line to calibrate;
- (4) After calibrating, according to the solid line connecting and testing Noise figure and record data;
- (5) Repeat RF channels to be tested for 800MHz of device and Repeat steps (2) to (4);

----- **The following blanks** -----

10.7.4 Test results

Test Date (yy-mm-dd): 2022-12-26

Normal condition: Temp:28.1°C, Humid: 27%, Atmospheric Pressure:101kpa

Supply Voltage: AC 110V, 50Hz

10.7.4.1 700MHz Band

Frequency(MHz)	Max. Limit (dB)	Noise figure data (dB)	Margin (dB)	Result
Downlink: 758~775	9	3.66	5.34	PASS
Uplink: 788~805	9	3.47	5.53	PASS
NOTE: Margin= specification limit - Noise figure data.				

10.7.4.2 800MHz Band

Frequency(MHz)	Max.Limit (dB)	Noise figure data (dB)	Margin (dB)	Result
Downlink: 851~861	9	2.66	6.34	PASS
Uplink: 806~816	9	3.14	5.86	PASS
NOTE: Margin= specification limit - Noise figure data.				

----- The following blanks -----

10.7.5 Test screenshot

10.7.5.1 700MHz Band

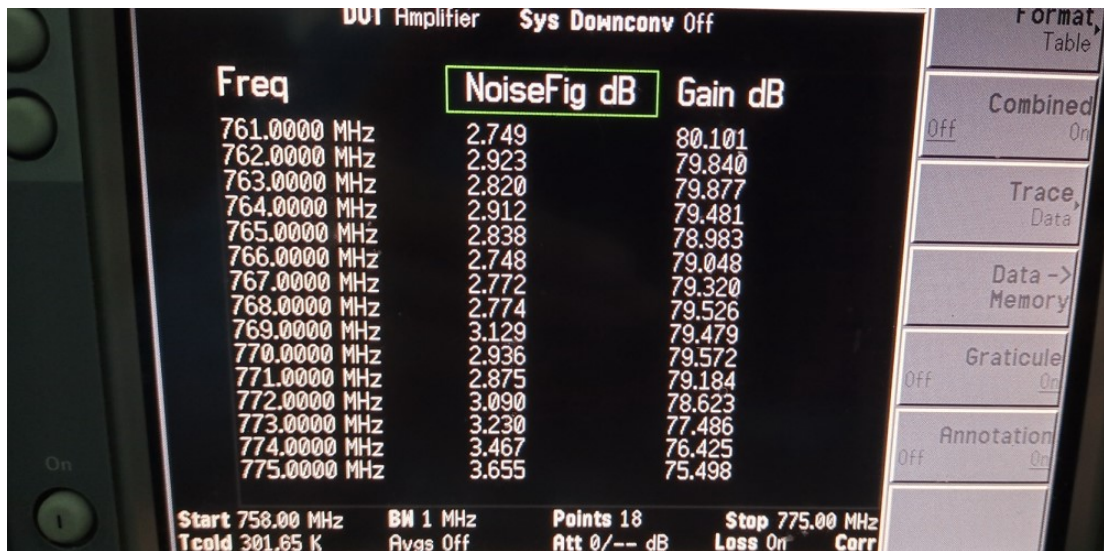
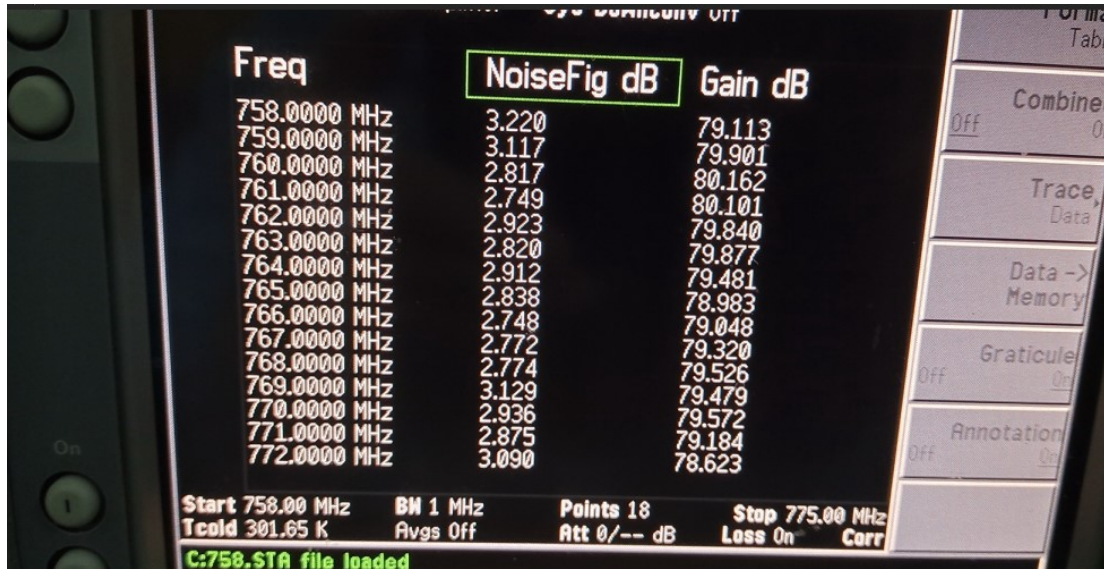

Downlink: 758MHz~775MHz

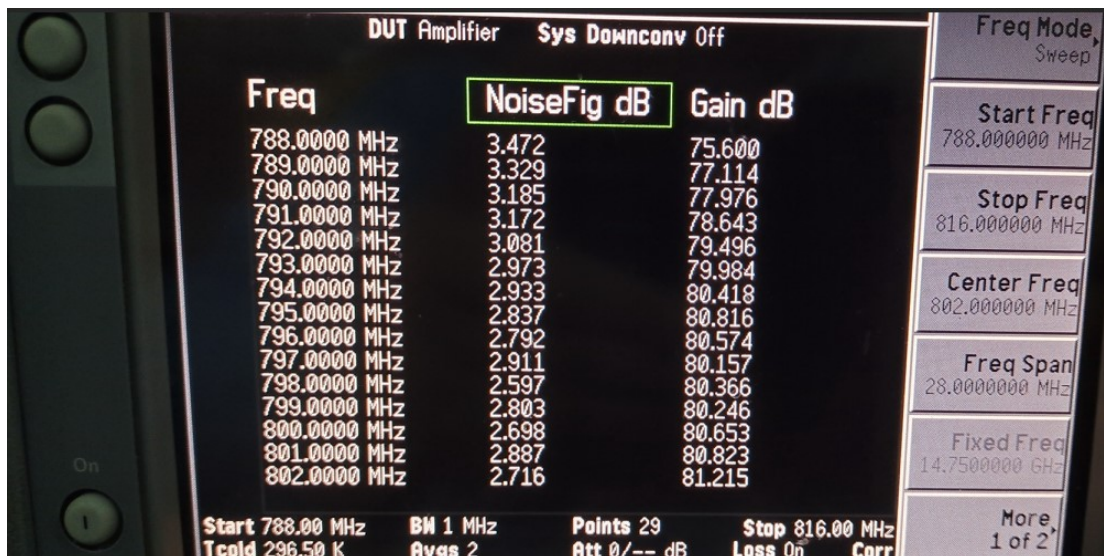

Freq	NoiseFig dB	Gain dB
801.0000 MHz	2.887	80.823
802.0000 MHz	2.716	81.215
803.0000 MHz	2.627	81.489
804.0000 MHz	2.675	81.656
805.0000 MHz	2.615	81.847
806.0000 MHz	2.826	81.727
807.0000 MHz	2.744	81.443
808.0000 MHz	2.748	80.859
809.0000 MHz	2.736	80.150
810.0000 MHz	2.761	79.406
811.0000 MHz	2.785	78.912
812.0000 MHz	2.785	78.703
813.0000 MHz	2.887	78.681

DUT Amplifier Sys Downconv Off

Frequency

Freq Mode Sweep

Start Freq 788.000000 MHz

Stop Freq 816.000000 MHz

Center Freq 802.000000 MHz

Freq Span 28.000000 MHz

Uplink: 788MHz~805MHz

10.7.5.2 800MHz Band

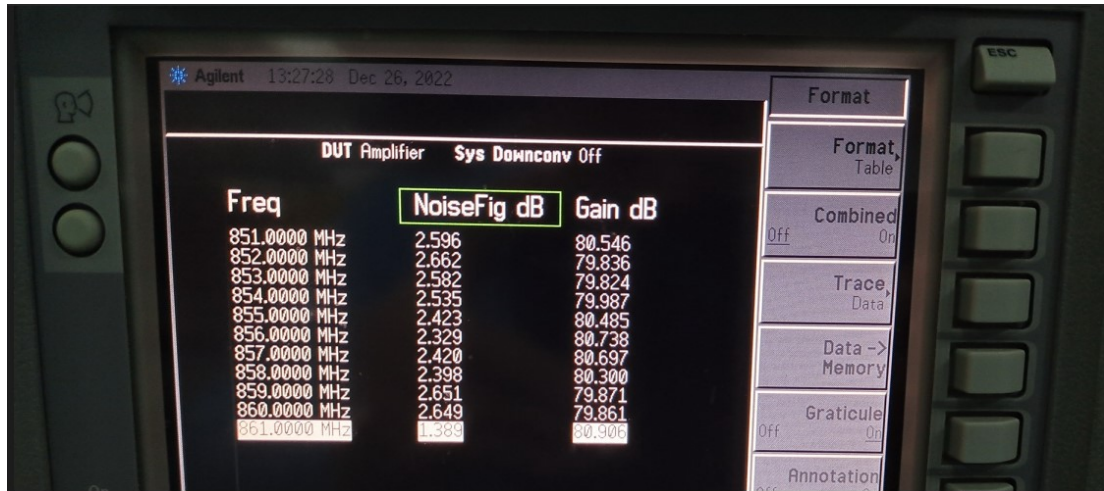

Downlink: 851MHz~861MHz

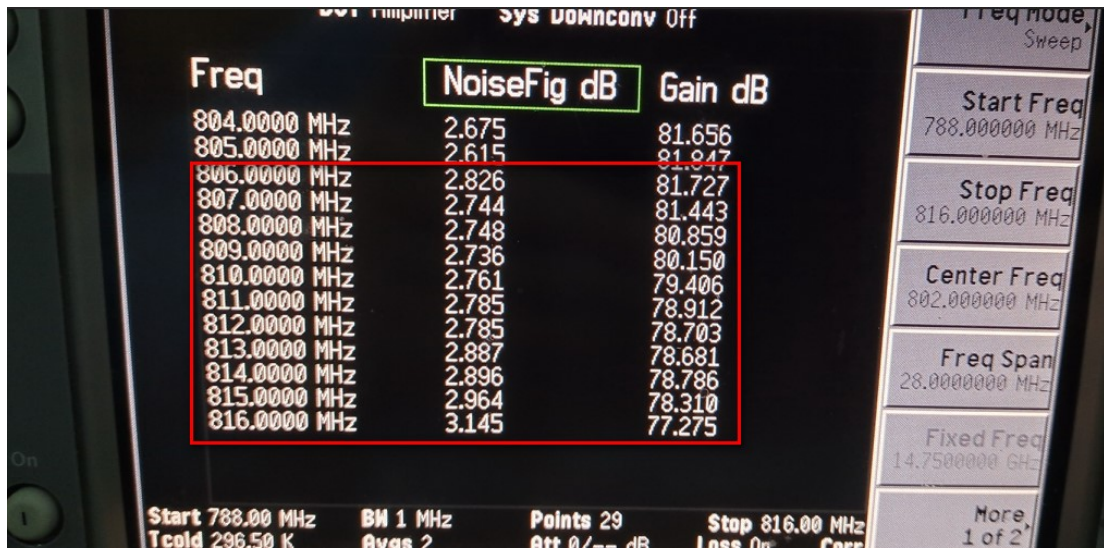

Uplink: 806MHz~816MHz

10.8 Out-of-band/out-of-block emissions

Test requirement: KDB 935210 D05 clause 4.7.2
 FCC PART 90.219 (d)(6)(i)
 FCC PART 90.219 (e)(3)

Test Method: KDB 935210 D05/4.7.1 and 4.7.2

10.8.1 Requirements

Refer to the applicable rule part(s) for specified limits on unwanted (out-of-band/out-of-block and spurious) emissions (e.g., Section 90.210).

Spurious emissions shall be measured using a single test signal sequentially tuned to the low, middle, and high channels or frequencies within each authorized frequency band of operation.

Intermodulation products shall be measured using two CW signals with all available channel spacings (e.g., 12.5 kHz and 6.25 kHz) with the center between these channels being equal to the center frequency f_0 as determined from 4.3.

NOTE—Intermodulation-product spurious emission measurements are not required for single-channel boosters that cannot accommodate two simultaneous signals within the passband.

For a multi-channel enhancer, any intermodulation product level must be attenuated, relative to P, by at least: $43 + 10 \cdot \log_{10} P$ is less stringent than 70dB, that limit was used.

Spurious emissions shall be measured using a single test signal sequentially tuned to the low, middle, and high channels or frequencies within each authorized frequency band of operation.

Out-of-band/out-of-block emissions (including intermodulation products) shall be measured under each of the following two stimulus conditions:

- a) two adjacent test signals sequentially tuned to the lower and upper frequency band/block edges;
- b) a single test signal, sequentially tuned to the lowest and highest frequencies or channels within the frequency band/block under examination.

NOTE—Single-channel boosters that cannot accommodate two simultaneous signals within the passband may be excluded from the test stipulated in step a).

----- The following blanks -----

10.8.2 Test configuration

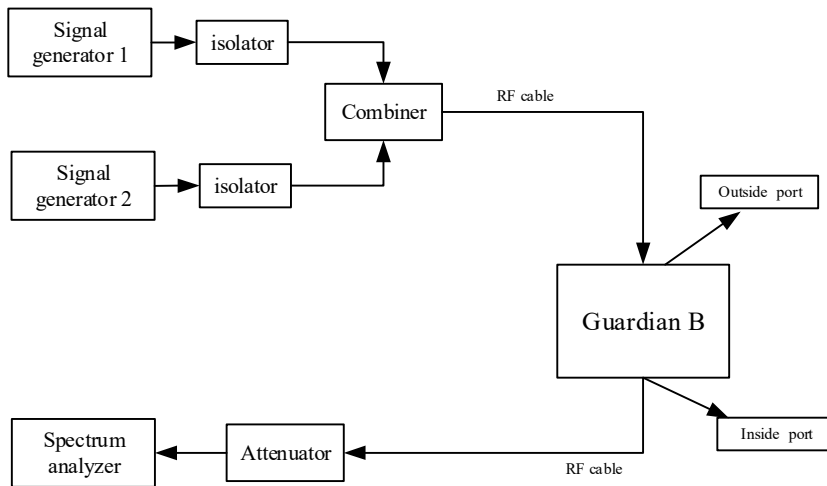

Figure 10.8-1 Downlink connection diagram

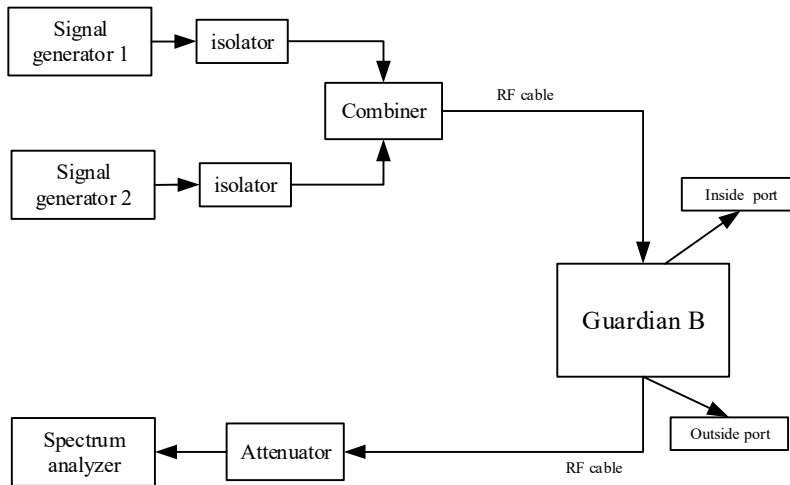

Figure 10.8-2 Uplink connection diagram

----- The following blanks -----

10.8.3 Test procedures

- a) Connect a signal generator to the input of the EUT.
If the signal generator is not capable of producing two independent modulated carriers simultaneously, then two discrete signal generators can be connected, with an appropriate combining network to support the two-signal test.
- b) Configure the two signal generators to produce CW on frequencies spaced consistent with 4.7.1, with amplitude levels set to just below the AGC threshold (see 4.2). Set the signal generator amplitudes so that the power from each into the EUT is equivalent.
- c) Connect a spectrum analyzer to the EUT output.
- d) Set the span to 100 kHz.
- e) Set RBW = 300 Hz with $VBW \geq 3 \times RBW$.
- f) Set the detector to power averaging (rms).
- g) Place a marker on highest intermodulation product amplitude.
- h) Capture the plot for inclusion in the test report.
- i) Repeat steps c) to h) with the composite input power level set to 3 dB above the AGC threshold.
- j) Repeat steps b) to i) for all operational bands.

Any frequency outside the authorized bandwidth was attenuated by at least $43+10*\log(P)$ dB. This corresponds to an absolute level of $-13\text{dBm} (P_{\text{dBm}}-(43+10*\log(P_{\text{W}})))$.

----- The following blanks -----

10.8.4 Test results

Test Date (yy-mm-dd): 2022-12-23~12-24

Normal condition: Temp: 23.1~23.9℃, Humid: 18~20%, Atmospheric Pressure:101kpa

Supply Voltage: AC 110V, 50Hz

10.8.4.1 700MHz Band**10.8.4.1.1 Downlink Transmit**

Test status	Test frequency	Intermodulation product Limit (dBm)	Max. intermodulation product (dBm)	Margin (dB)	Result
(1) Frequency range: 758MHz~775MHz (758 ~ 768MHz is LTE band)					
(1.1) Channel Bandwidth: 12.5kHz					
With the ALC threshold level	Low frequency: f1:768.00625MHz f2:768.01875MHz	-13.0	-22.0	9.0	PASS
	Mid frequency: f1:771.50MHz f2:771.5125MHz	-13.0	-23.6	10.6	PASS
	High frequency: f1:774.98125MHz f2:774.99375MHz	-13.0	-22.9	9.9	PASS
With the input signal amplitude set 3 dB above the AGC threshold	Low frequency: f1:768.00625MHz f2:768.01875MHz	-13.0	-21.9	8.9	PASS
	Mid frequency: f1:771.50MHz f2:771.5125MHz	-13.0	-23.3	10.3	PASS
	High frequency: f1:774.98125MHz f2:774.99375MHz	-13.0	-23.1	10.1	PASS
(1.2) Channel Bandwidth: 25kHz					
With the ALC threshold level	Low frequency: f1:768.0125MHz f2:768.0375MHz	-13.0	-22.4	9.4	PASS
	Mid frequency: f1:771.50MHz f2:771.525MHz	-13.0	-22.8	9.8	PASS
	High frequency: f1:774.9625MHz f2:774.9875MHz	-13.0	-22.8	9.8	PASS
With the input signal amplitude set 3 dB above the AGC threshold	Low frequency: f1:768.0125MHz f2:768.0375MHz	-13.0	-22.2	9.2	PASS
	Mid frequency: f1:771.50MHz f2:771.525MHz	-13.0	-22.8	9.8	PASS
	High frequency: f1:774.9625MHz f2:774.9875MHz	-13.0	-23.3	10.3	PASS
NOTE 1: Intermodulation products select the worst data record.					
NOTE 2: Margin= specification limit -Maximum mark level.					

10.8.4.1.2 Uplink Transmit

Test status	Test frequency	Intermodulation product Limit (dBm)	Max. intermodulation product (dBm)	Margin (dB)	Result
(2) Frequency range: 798MHz~805MHz(788 ~ 798MHz is LTE band)					
(2.1) Channel Bandwidth: 12.5kHz					
With the ALC threshold level	Low frequency: f1:798.00625MHz f2:798.01875MHz	-13.0	-23.2	10.2	PASS
	Mid frequency: f1:801.5MHz f2:801.5125MHz	-13.0	-22.2	9.2	PASS
	High frequency: f1:804.98125MHz f2:804.99375MHz	-13.0	-21.9	8.9	PASS
With the input signal amplitude set 3 dB above the AGC threshold	Low frequency: f1:798.00625MHz f2:798.01875MHz	-13.0	-22.3	9.3	PASS
	Mid frequency: f1:801.5MHz f2:801.5125MHz	-13.0	-21.5	8.5	PASS
	High frequency: f1:804.98125MHz f2:804.99375MHz	-13.0	-21.0	8.0	PASS
(2.2) Channel Bandwidth: 25kHz					
With the ALC threshold level	Low frequency: f1:798.0125MHz f2:798.0375MHz	-13.0	-22.9	9.9	PASS
	Mid frequency: f1:801.5MHz f2:801.525MHz	-13.0	-21.7	8.7	PASS
	High frequency: f1:804.9625MHz f2:804.9875MHz	-13.0	-21.3	8.3	PASS
With the input signal amplitude set 3 dB above the AGC threshold	Low frequency: f1:798.0125MHz f2:798.0375MHz	-13.0	-22.0	9.0	PASS
	Mid frequency: f1:801.5MHz f2:801.525MHz	-13.0	-21.1	8.1	PASS
	High frequency: f1:804.9625MHz f2:804.9875MHz	-13.0	-20.5	7.5	PASS
NOTE 1: Intermodulation products select the worst data record. NOTE 2: Margin= specification limit -Maximum mark level.					

10.8.4.2 800MHz Band**10.8.4.2.1 Downlink Transmit**

Test status	Test frequency	Intermodulation product Limit (dBm)	Max. intermodulation product (dBm)	Margin (dB)	Result
(3) Frequency range: 851MHz~861MHz					
(3.1) Channel Bandwidth: 12.5kHz					
With the ALC threshold level	Low frequency: f1:851.00625MHz f2:851.01875MHz	-13.0	-16.0	3.0	PASS
	Mid frequency: f1:856.0MHz f2:856.0125MHz	-13.0	-16.8	3.8	PASS
	High frequency: f1:860.98125MHz f2:860.99375MHz	-13.0	-15.5	2.5	PASS
With the input signal amplitude set 3 dB above the AGC threshold	Low frequency: f1:851.00625MHz f2:851.01875MHz	-13.0	-16.1	3.1	PASS
	Mid frequency: f1:856.0MHz f2:856.0125MHz	-13.0	-16.8	3.8	PASS
	High frequency: f1:860.98125MHz f2:860.99375MHz	-13.0	-15.6	2.6	PASS
(3.2) Channel Bandwidth: 25kHz					
With the ALC threshold level	Low frequency: f1:851.0125MHz f2:851.0375MHz	-13.0	-15.3	2.3	PASS
	Mid frequency: f1:856.0MHz f2:856.025MHz	-13.0	-16.3	3.3	PASS
	High frequency: f1:860.9625MHz f2:860.9875MHz	-13.0	-14.8	1.8	PASS
With the input signal amplitude set 3 dB above the AGC threshold	Low frequency: f1:851.0125MHz f2:851.0375MHz	-13.0	-15.6	2.6	PASS
	Mid frequency: f1:856.0MHz f2:856.025MHz	-13.0	-16.5	3.5	PASS
	High frequency: f1:860.9625MHz f2:860.9875MHz	-13.0	-15.1	2.1	PASS
NOTE 1: Intermodulation products select the worst data record.					
NOTE 2: Margin= specification limit -Maximum mark level.					

10.8.4.2.2 Uplink Transmit

Test status	Test frequency	Intermodulation product Limit (dBm)	Max. intermodulation product (dBm)	Margin (dB)	Result
(4) Frequency range: 806MHz~816MHz					
(4.1) Channel Bandwidth: 12.5kHz					
With the ALC threshold level	Low frequency: f1:806.00625MHz f2:806.01875MHz	-13.0	-20.4	7.4	PASS
	Mid frequency: f1:811.0MHz f2:811.0125MHz	-13.0	-22.4	9.4	PASS
	High frequency: f1:815.98125MHz f2:815.99375MHz	-13.0	-22.1	9.1	PASS
With the input signal amplitude set 3 dB above the AGC threshold	Low frequency: f1:806.00625MHz f2:806.01875MHz	-13.0	-21.8	8.8	PASS
	Mid frequency: f1:811.0MHz f2:811.0125MHz	-13.0	-21.5	8.5	PASS
	High frequency: f1:815.98125MHz f2:815.99375MHz	-13.0	-22.8	9.8	PASS
(4.2) Channel Bandwidth: 25kHz					
With the ALC threshold level	Low frequency: f1:806.0125MHz f2:806.0375MHz	-13.0	-20.4	7.4	PASS
	Mid frequency: f1:811.0MHz f2:811.025MHz	-13.0	-22.5	9.5	PASS
	High frequency: f1:815.9625MHz f2:815.9875MHz	-13.0	-22.2	9.2	PASS
With the input signal amplitude set 3 dB above the AGC threshold	Low frequency: f1:806.0125MHz f2:806.0375MHz	-13.0	-21.9	8.9	PASS
	Mid frequency: f1:811.0MHz f2:811.025MHz	-13.0	-21.5	8.5	PASS
	High frequency: f1:815.9625MHz f2:815.9875MHz	-13.0	-23.1	10.1	PASS
NOTE 1: Intermodulation products select the worst data record.					
NOTE 2: Margin= specification limit -Maximum mark level.					

10.8.5 Test screenshot

10.8.5.1 700MHz Band

10.8.5.1.1 Channel bandwidth 12.5kHz

10.8.5.1.1.1 Downlink

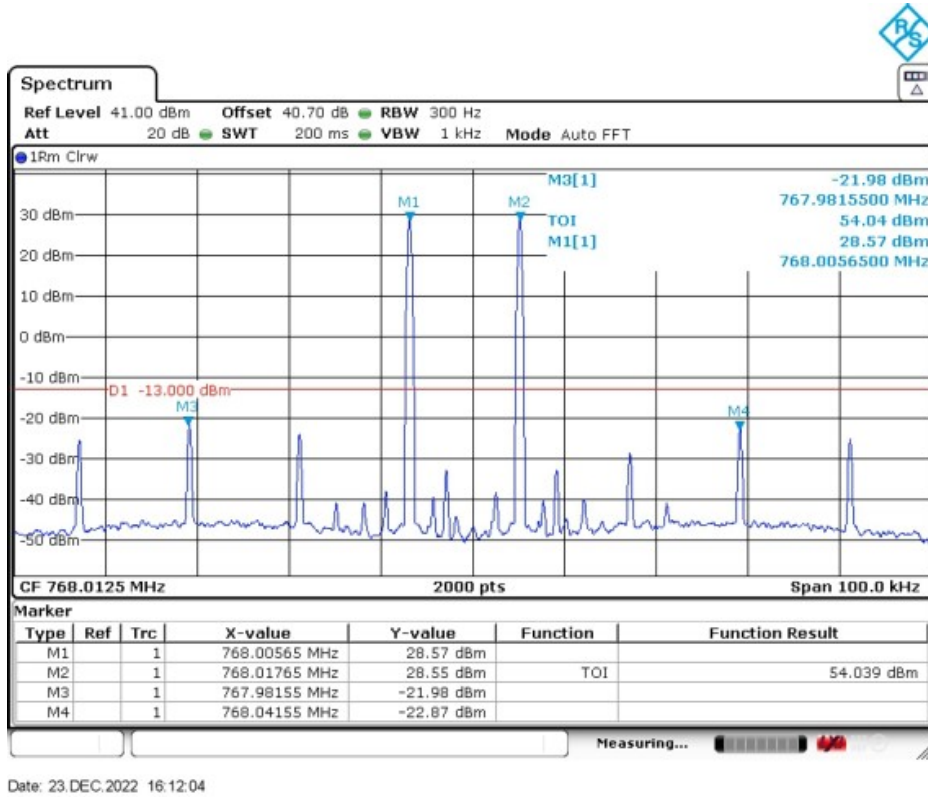

Low Frequency and with the ALC threshold level

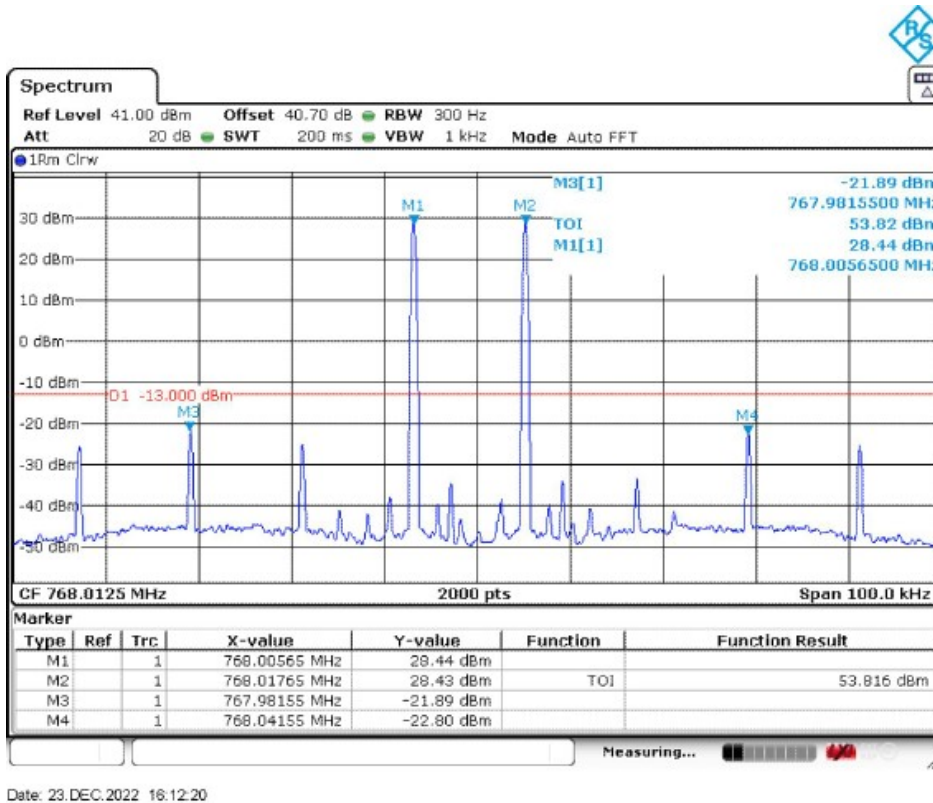

Low Frequency and with the input signal amplitude set 3 dB above the ALC threshold

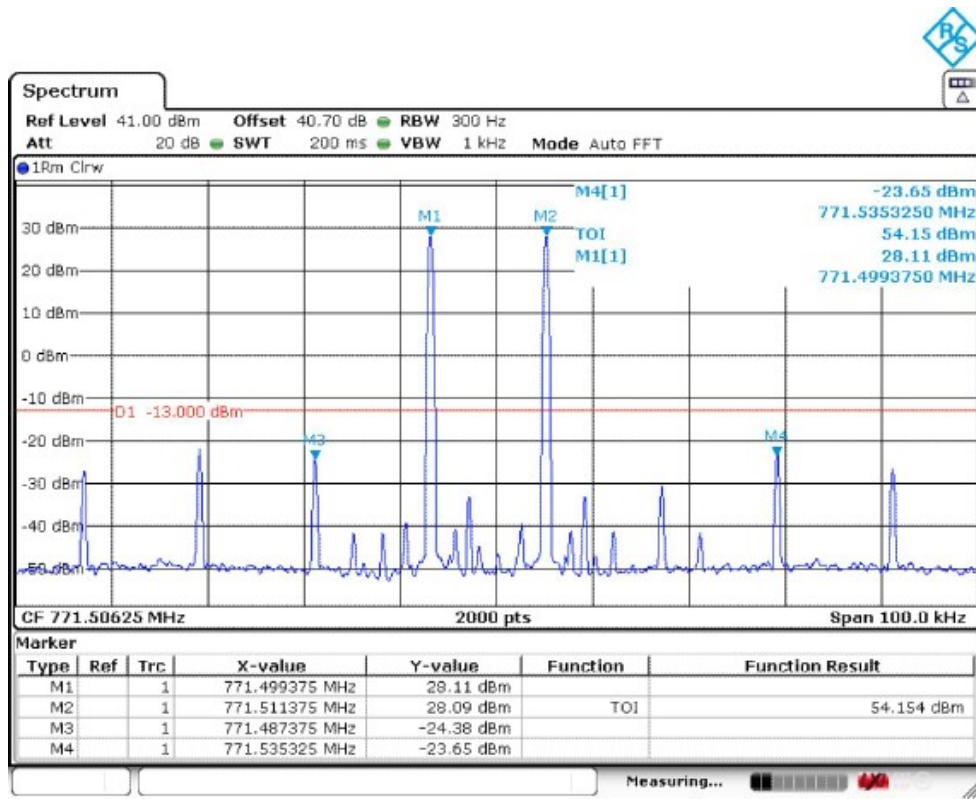

Date: 23.DEC.2022 16:14:11

Mid Frequency and with the ALC threshold level

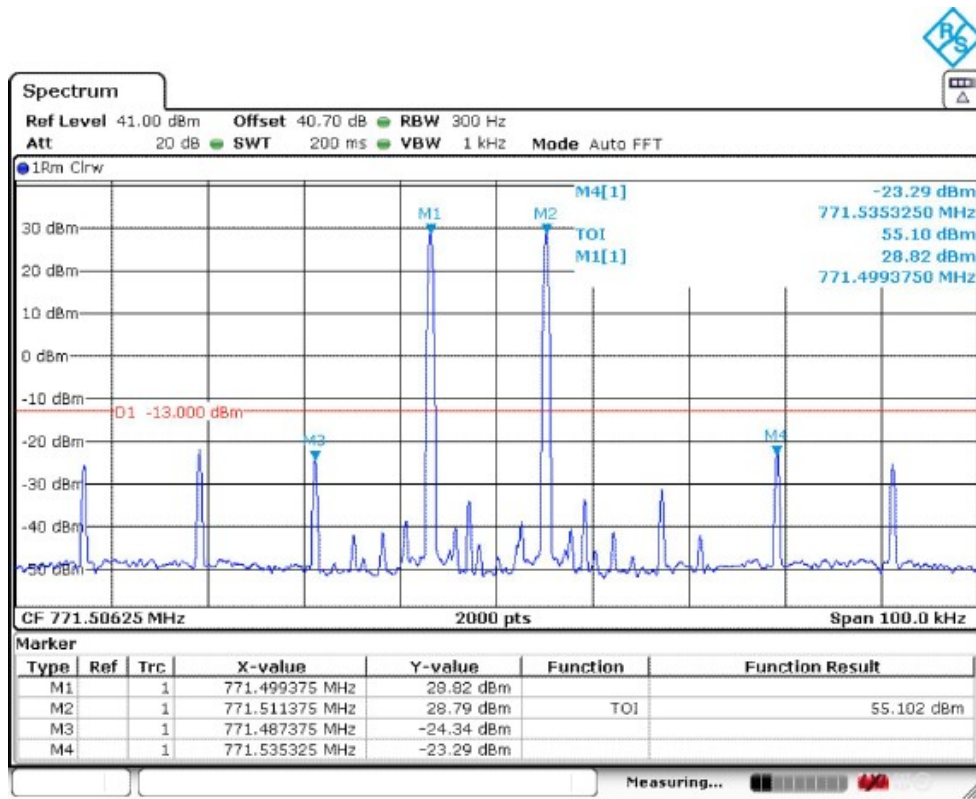

Date: 23.DEC.2022 16:13:50

Mid Frequency and with the input signal amplitude set 3 dB above the ALC threshold

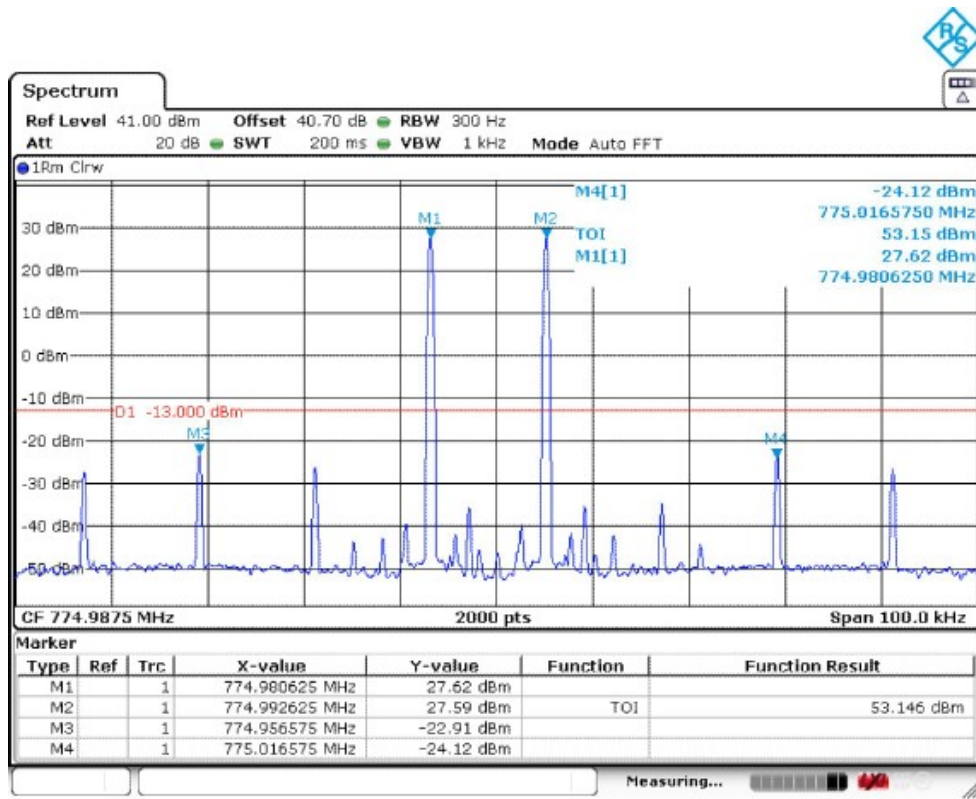

Date: 23.DEC.2022 16:15:36

High Frequency and with the ALC threshold level

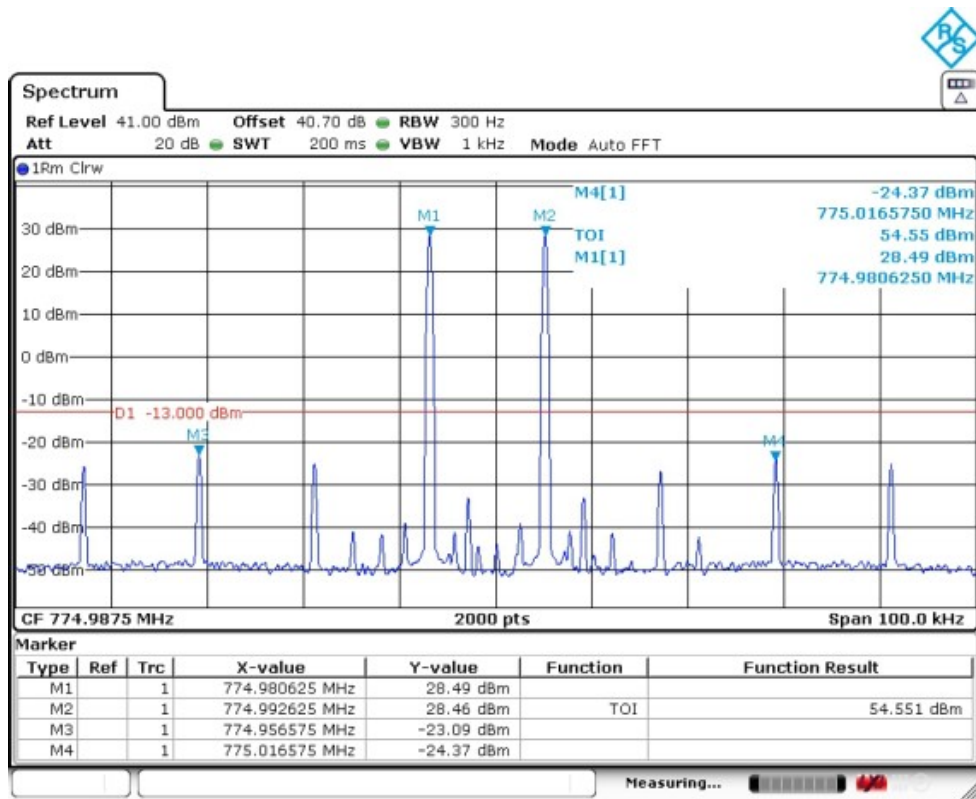

Date: 23.DEC.2022 16:15:54

High Frequency and with the input signal amplitude set 3 dB above the ALC threshold

10.8.5.1.1.2 Uplink

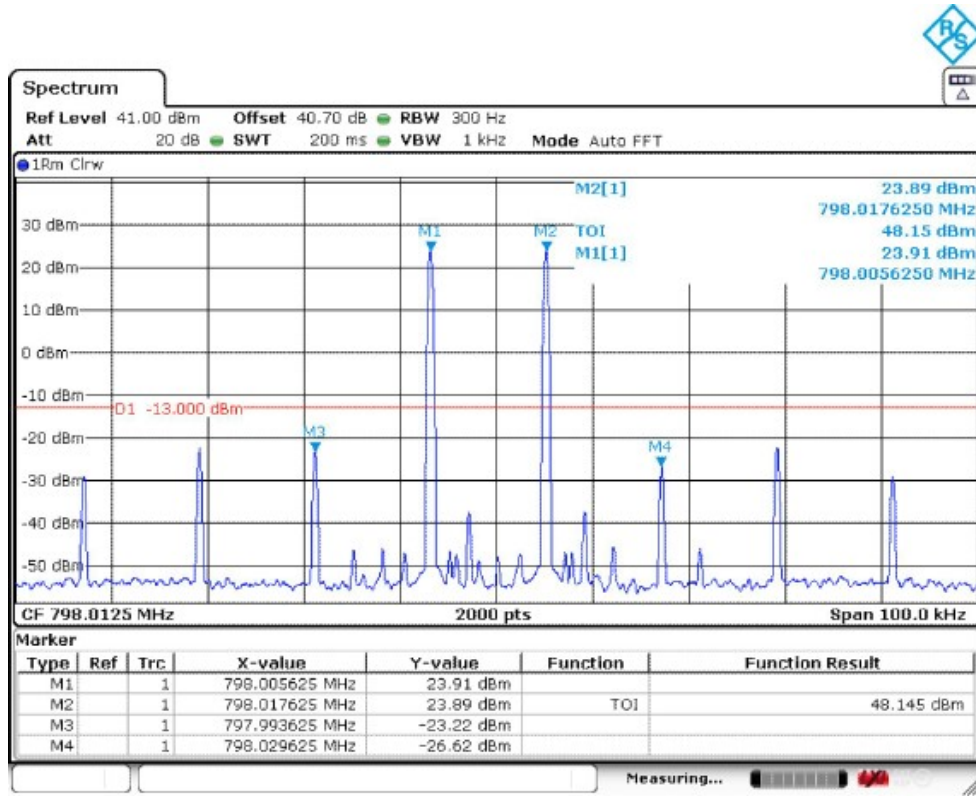

Date: 24.DEC.2022 08:51:01

Low Frequency and with the ALC threshold level

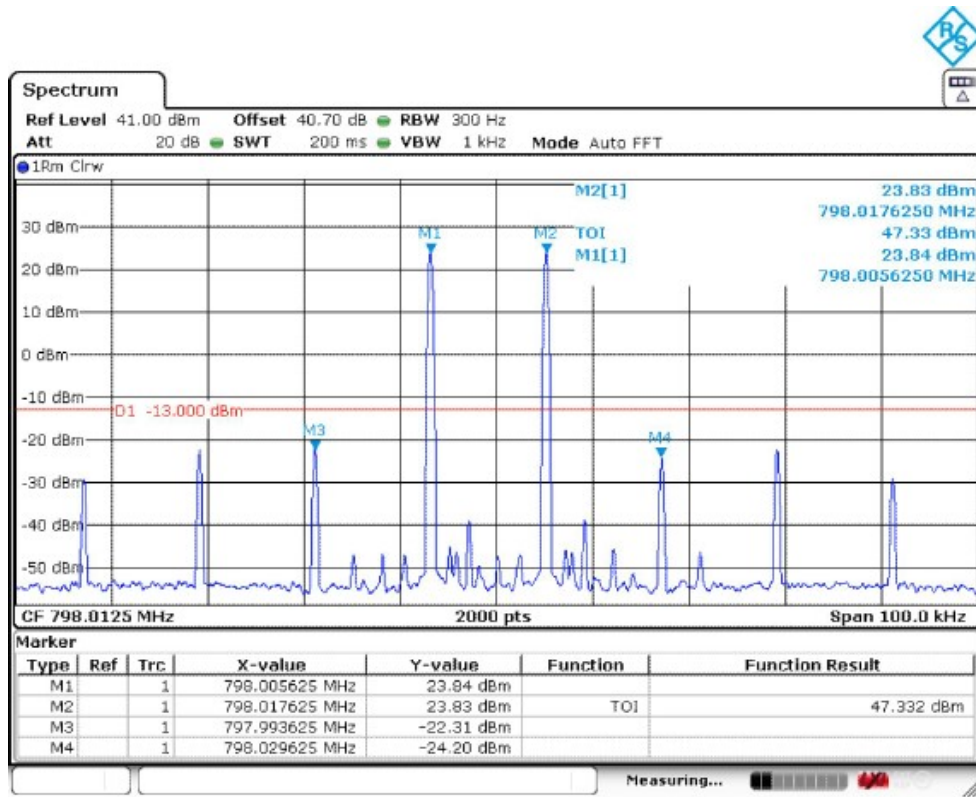

Date: 24.DEC.2022 08:51:18

Low Frequency and with the input signal amplitude set 3 dB above the ALC threshold

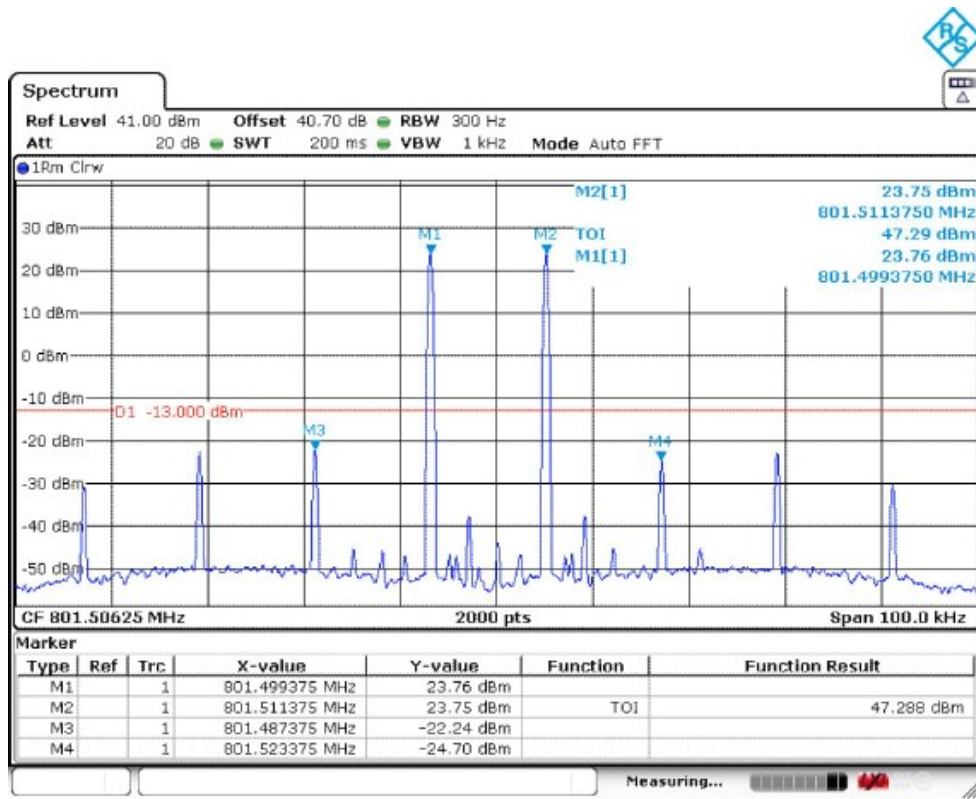

Date: 24.DEC.2022 08:52:19

Mid Frequency and with the ALC threshold level

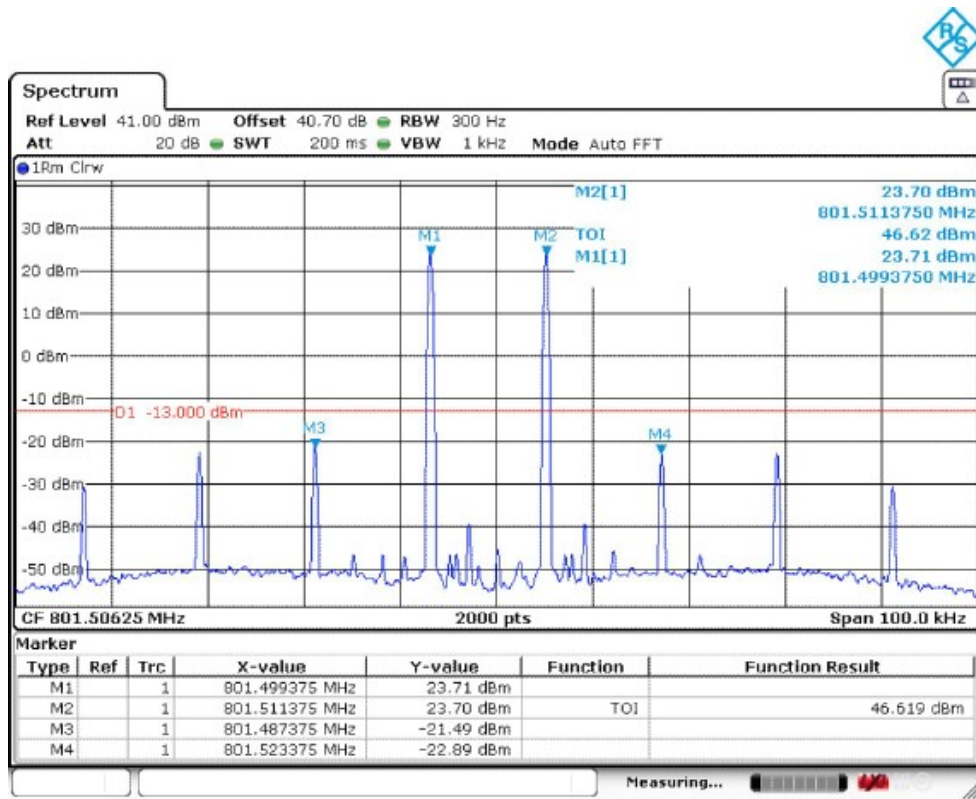

Date: 24.DEC.2022 08:52:29

Mid Frequency and with the input signal amplitude set 3 dB above the ALC threshold

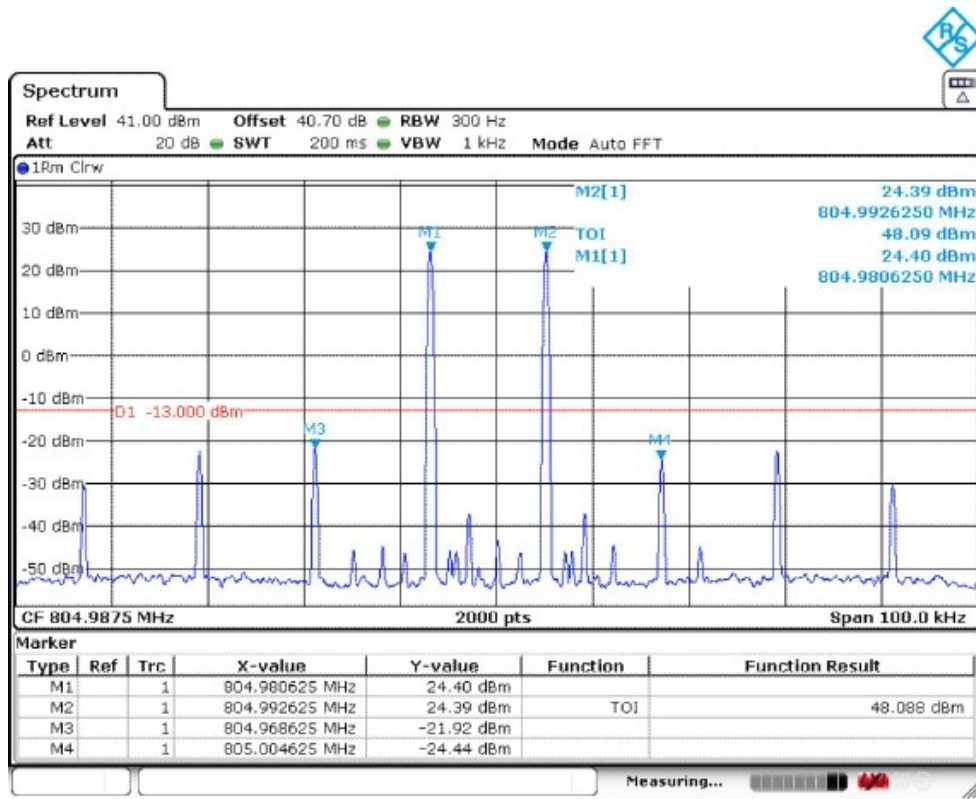

Date: 24.DEC.2022 08:53:10

High Frequency and with the ALC threshold level

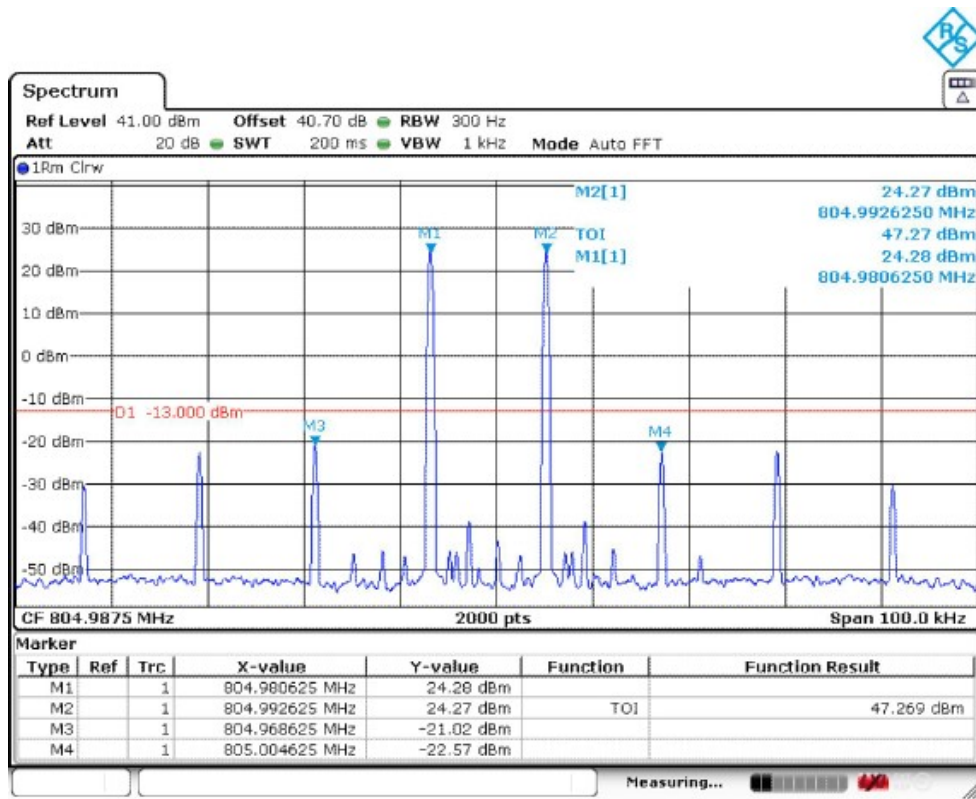

Date: 24.DEC.2022 08:53:16

High Frequency and with the input signal amplitude set 3 dB above the ALC threshold

10.8.5.1.2 Channel bandwidth 25kHz

10.8.5.1.2.1 Downlink

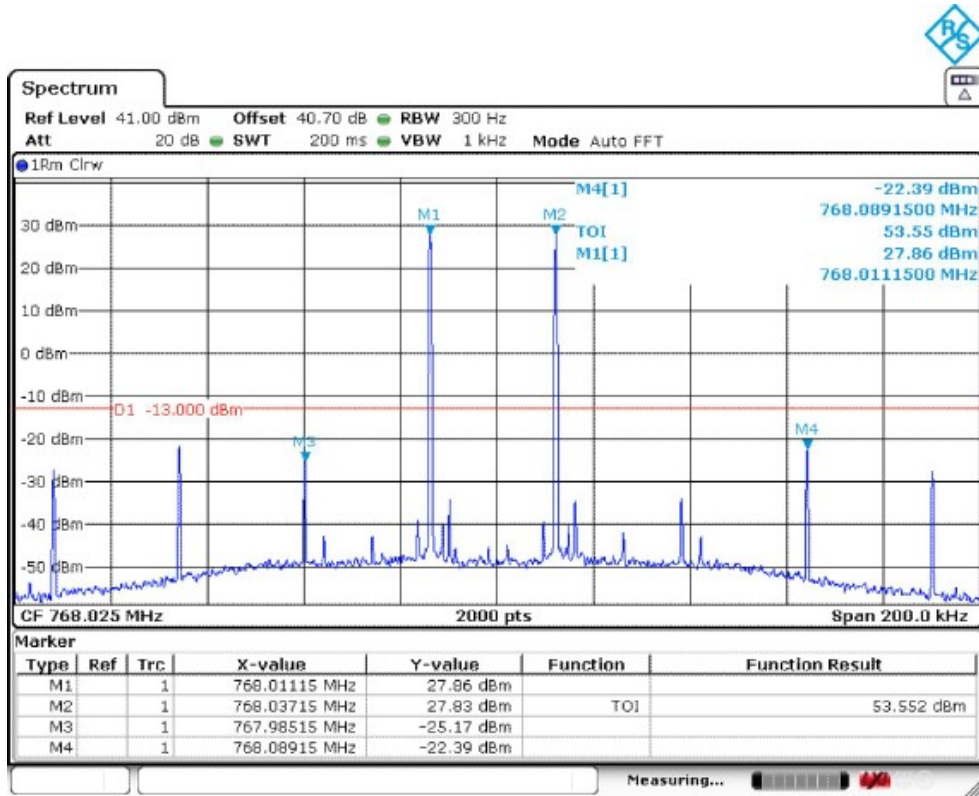

Date: 23.DEC.2022 16:21:27

Low Frequency and with the ALC threshold level

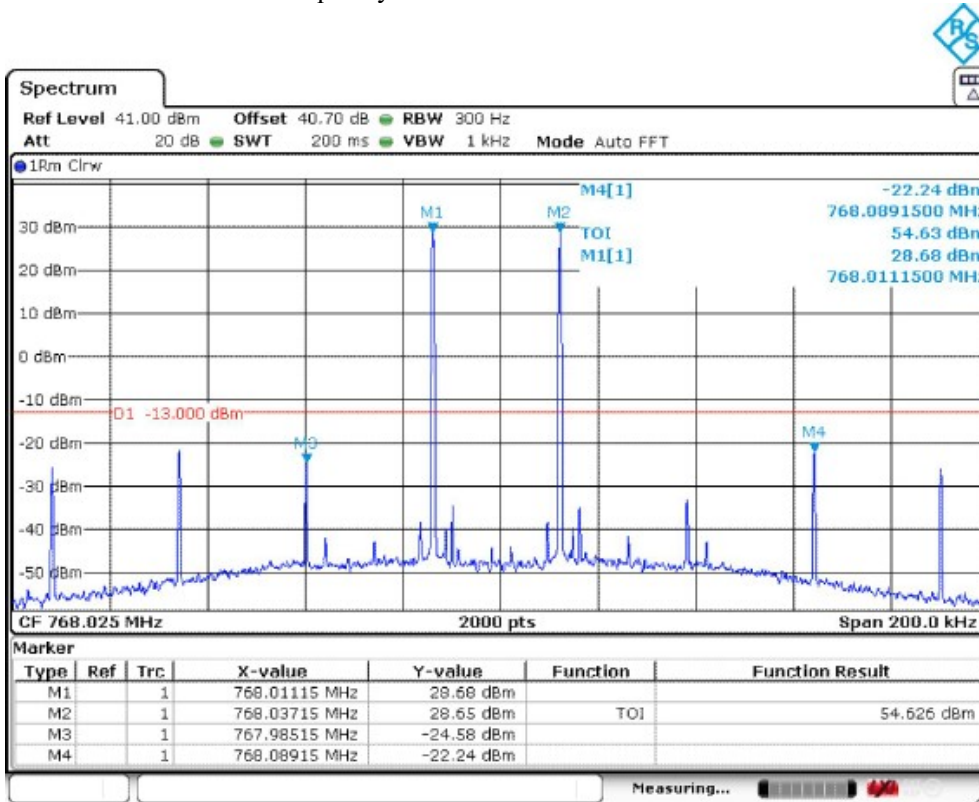

Date: 23.DEC.2022 16:21:41

Low Frequency and with the input signal amplitude set 3 dB above the ALC threshold

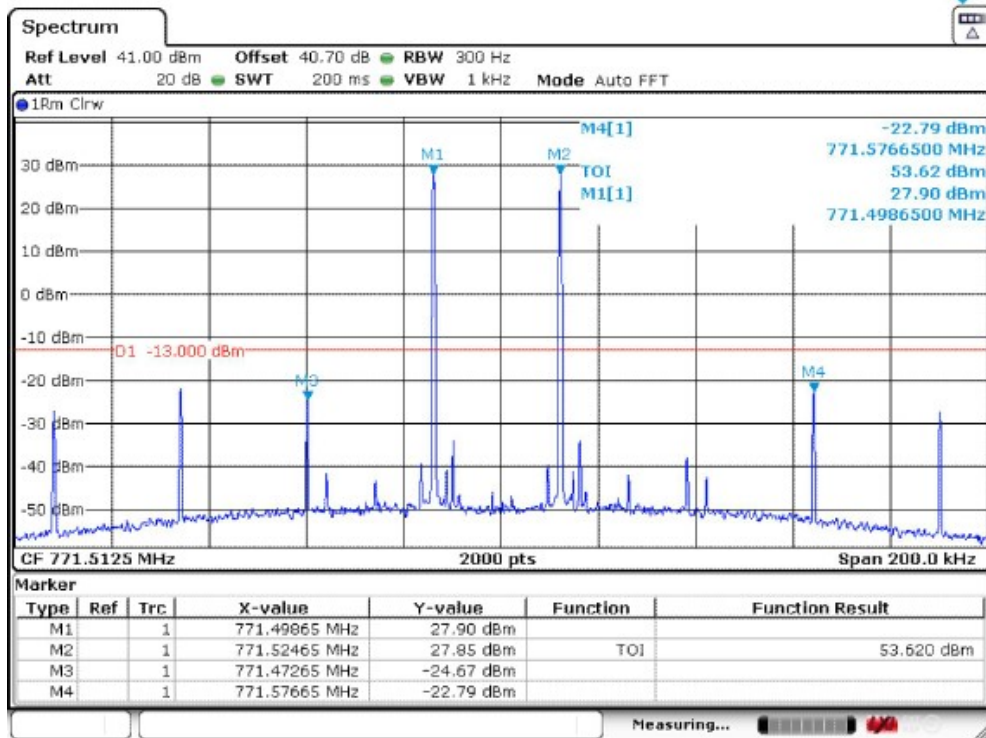

Date: 23.DEC.2022 16:20:03

Mid Frequency and with the ALC threshold level

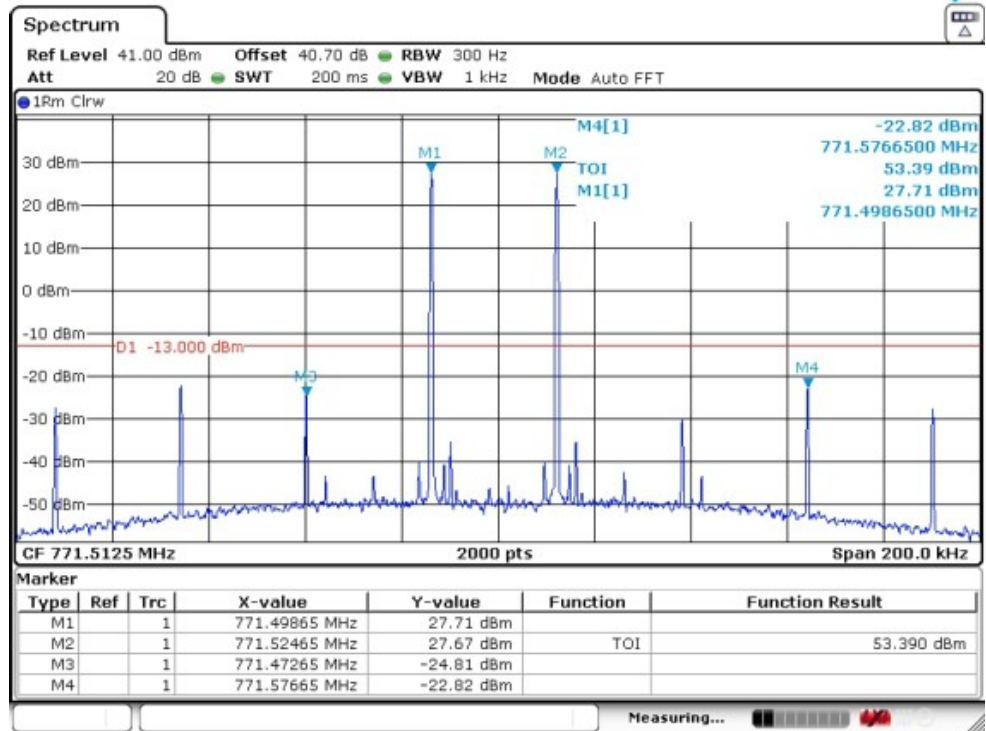

Date: 23.DEC.2022 16:20:21

Mid Frequency and with the input signal amplitude set 3 dB above the ALC threshold

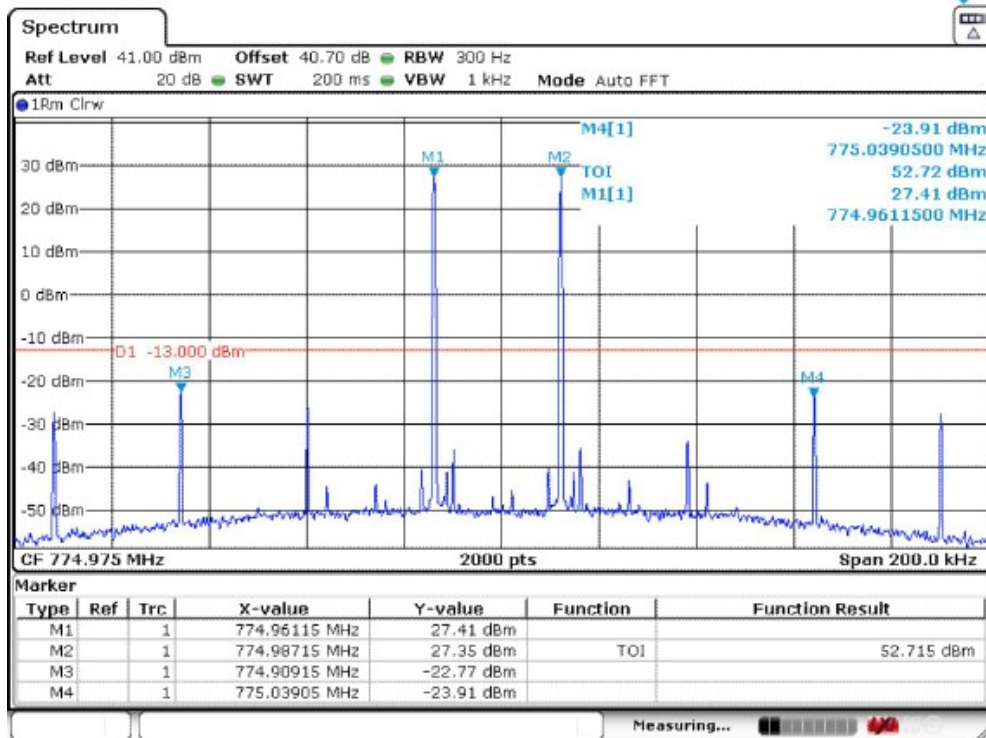

Date: 23.DEC.2022 16:18:00

High Frequency and with the ALC threshold level

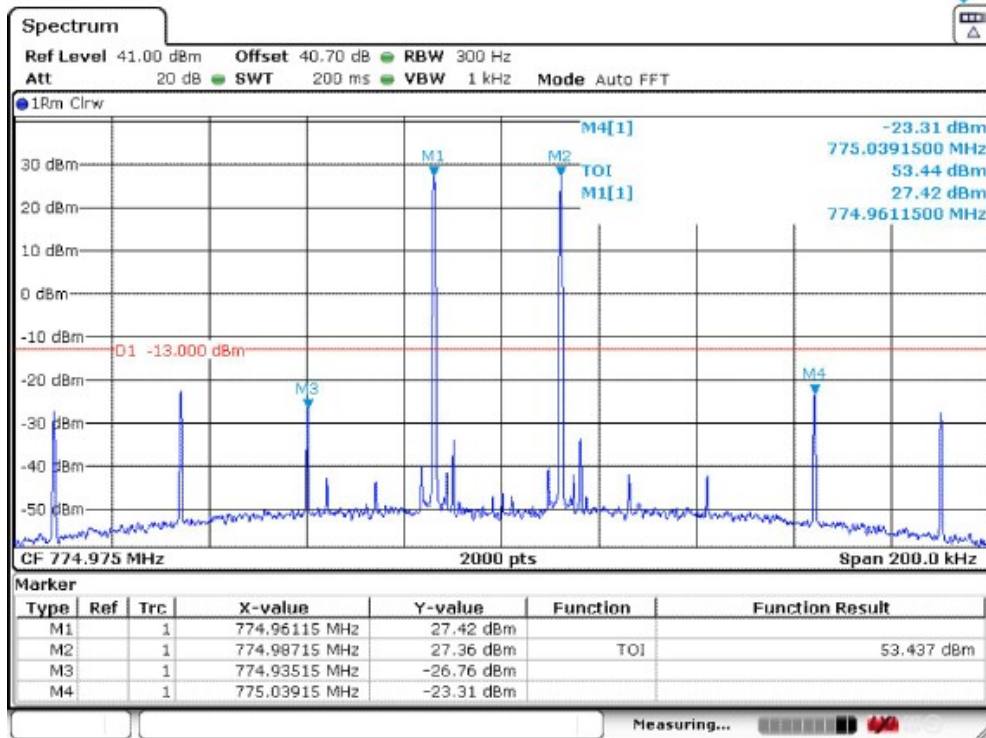

Date: 23.DEC.2022 16:18:50

High Frequency and with the input signal amplitude set 3 dB above the ALC threshold

10.8.5.1.2.2 Uplink

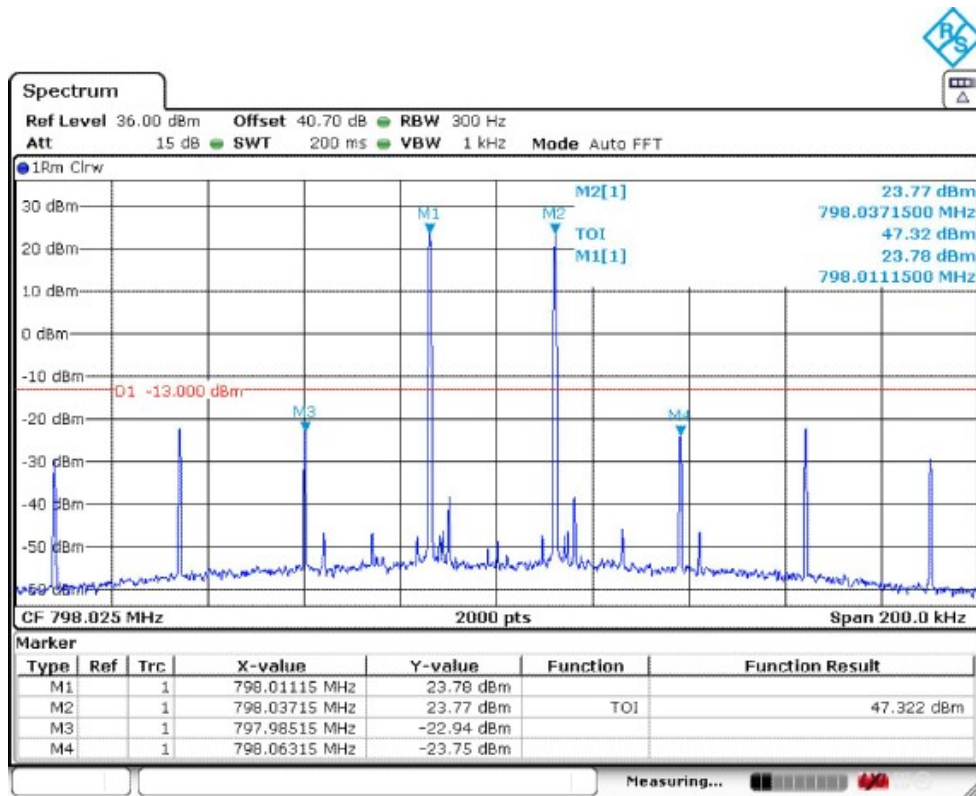

Low Frequency and with the ALC threshold level

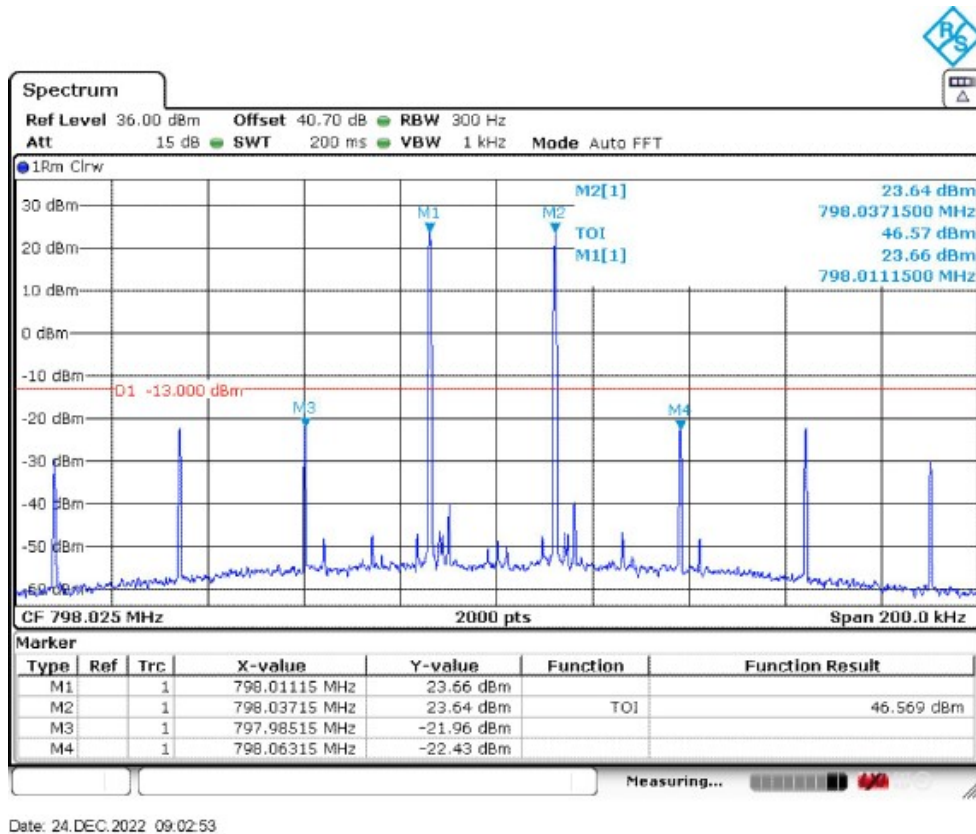

Low Frequency and with the input signal amplitude set 3 dB above the ALC threshold

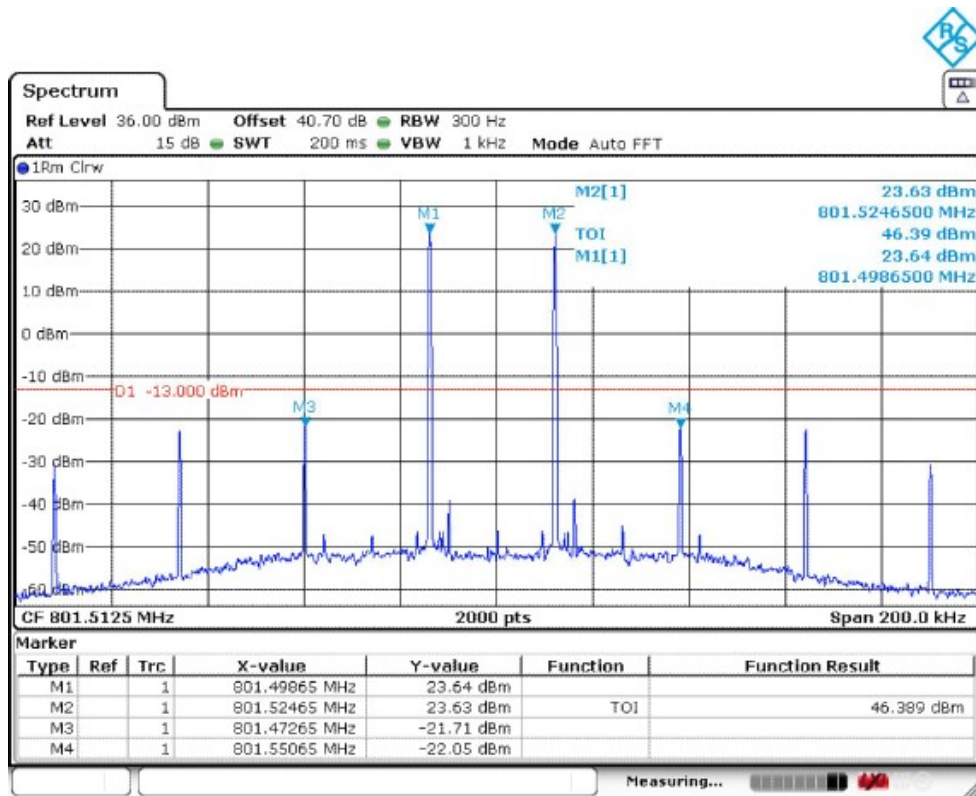

Mid Frequency and with the ALC threshold level

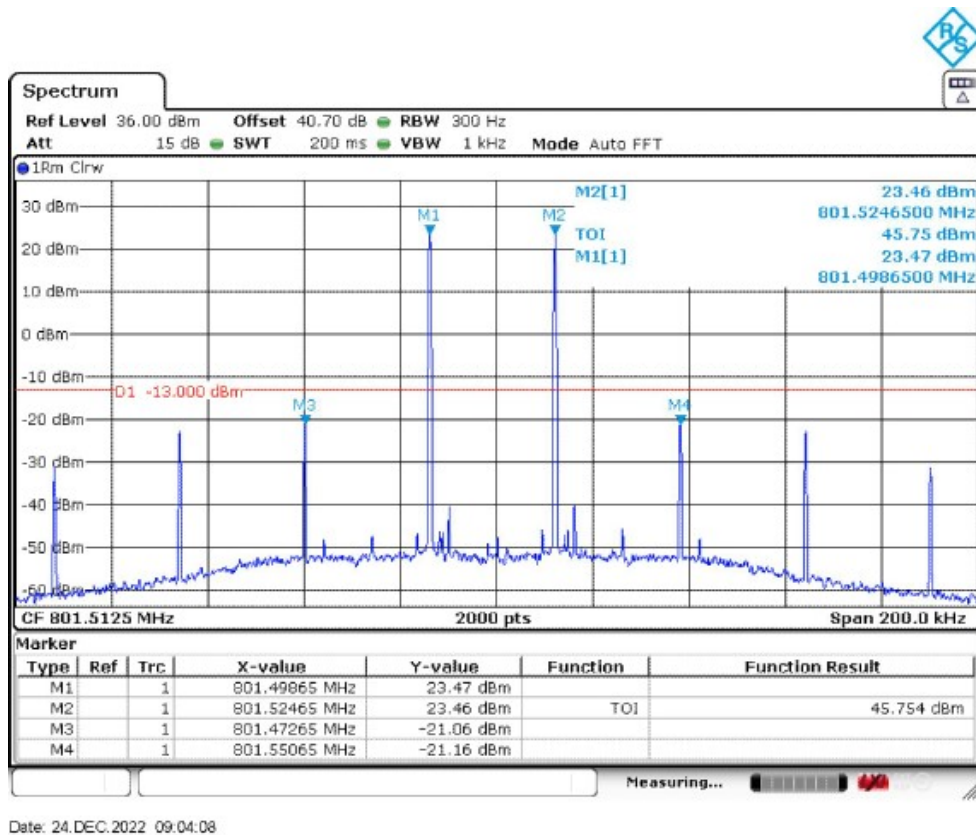

Mid Frequency and with the input signal amplitude set 3 dB above the ALC threshold

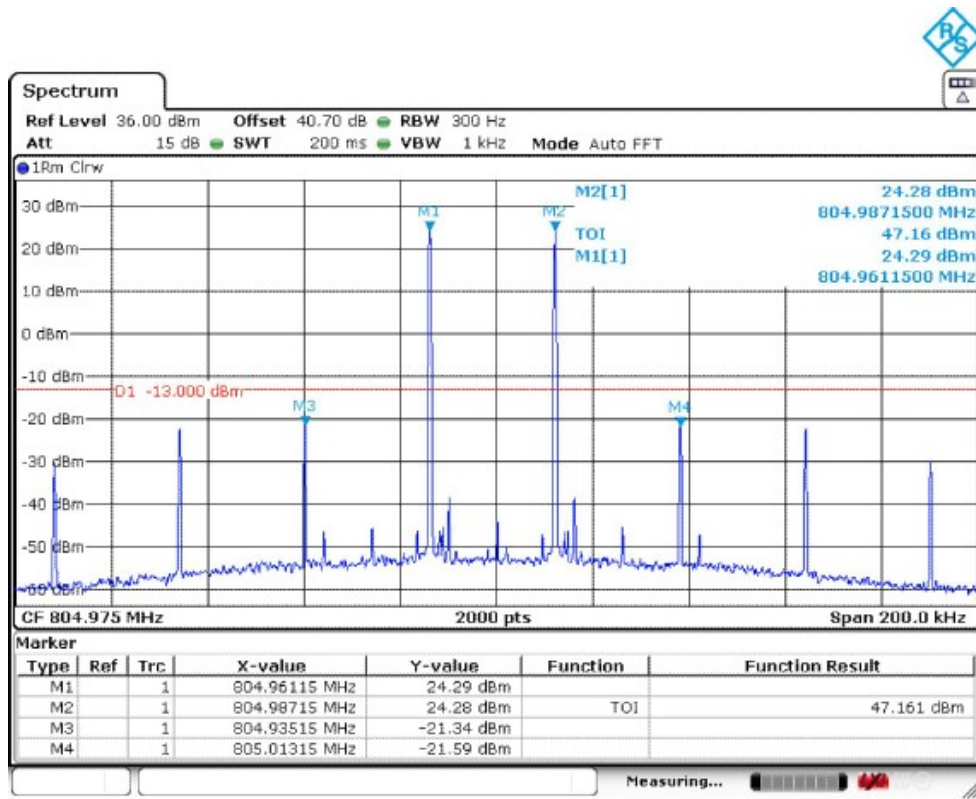

High Frequency and with the ALC threshold level

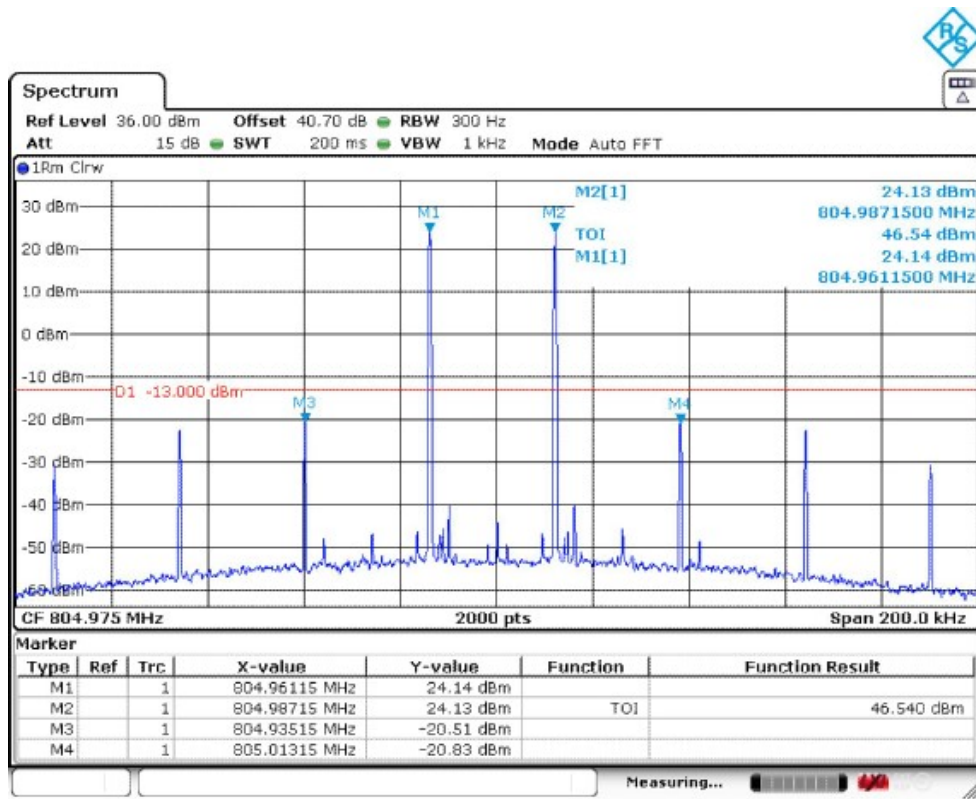

High Frequency and with the input signal amplitude set 3 dB above the ALC threshold

10.8.5.2 800MHz Band

10.8.5.2.1 Channel bandwidth 12.5kHz

10.8.5.2.1.1 Downlink

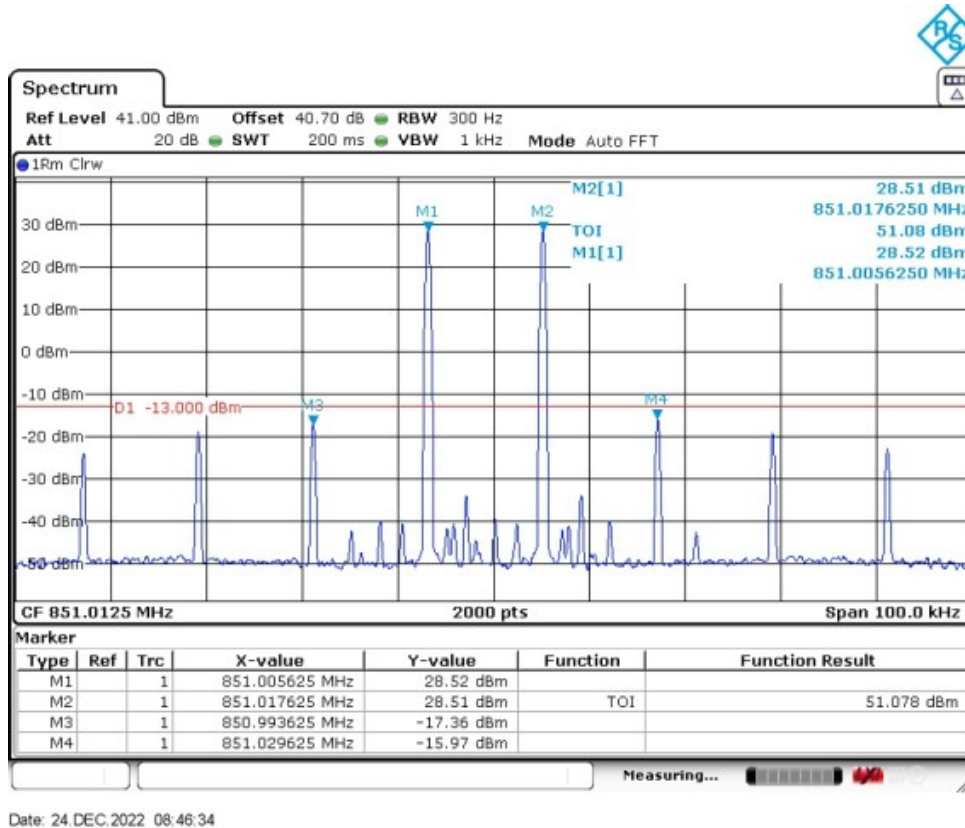

Low Frequency and with the ALC threshold level

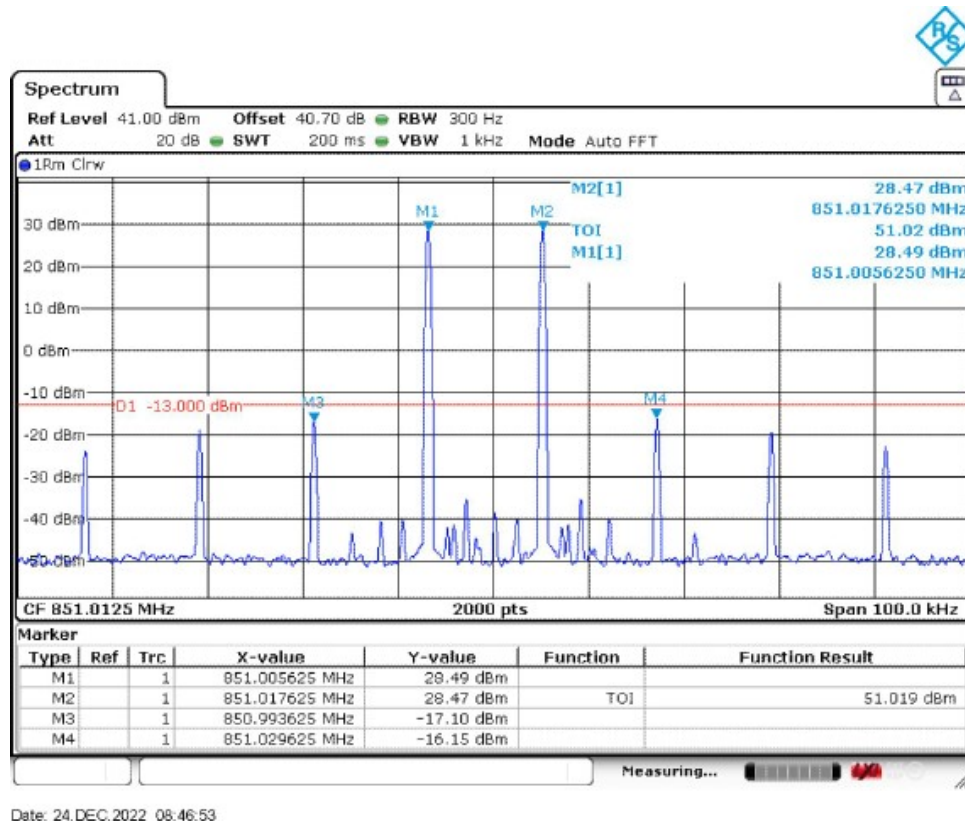

Low Frequency and with the input signal amplitude set 3 dB above the ALC threshold

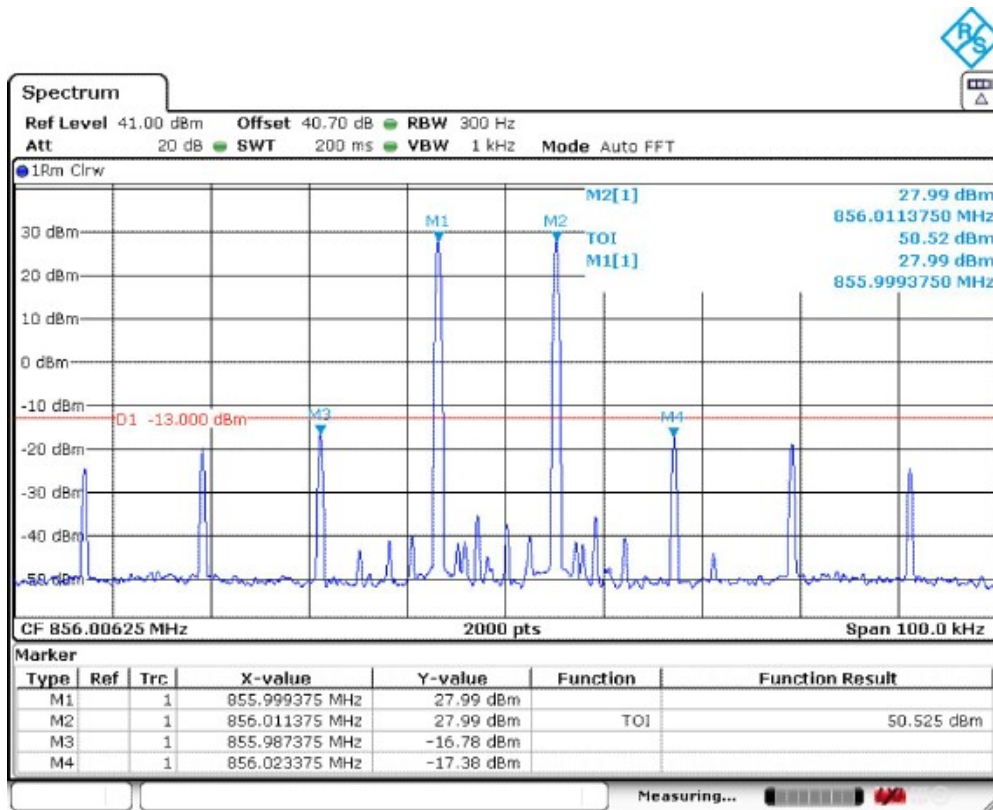

Date: 24.DEC.2022 08:47:56

Mid Frequency and with the ALC threshold level

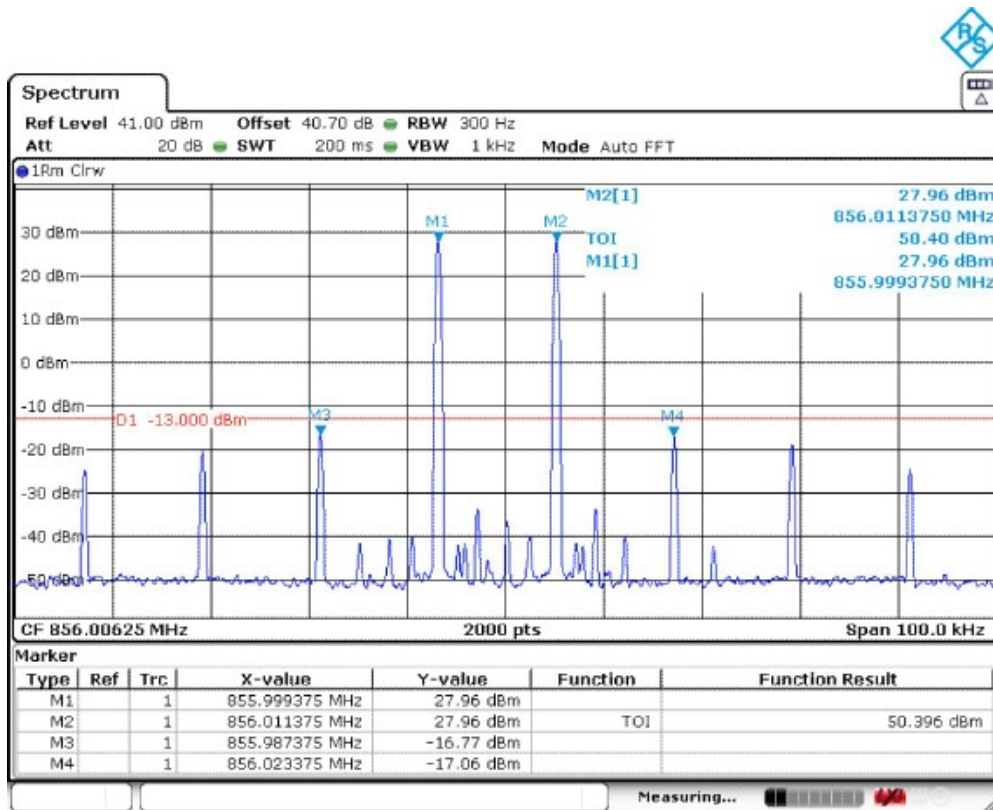

Date: 24.DEC.2022 08:48:28

Mid Frequency and with the input signal amplitude set 3 dB above the ALC threshold

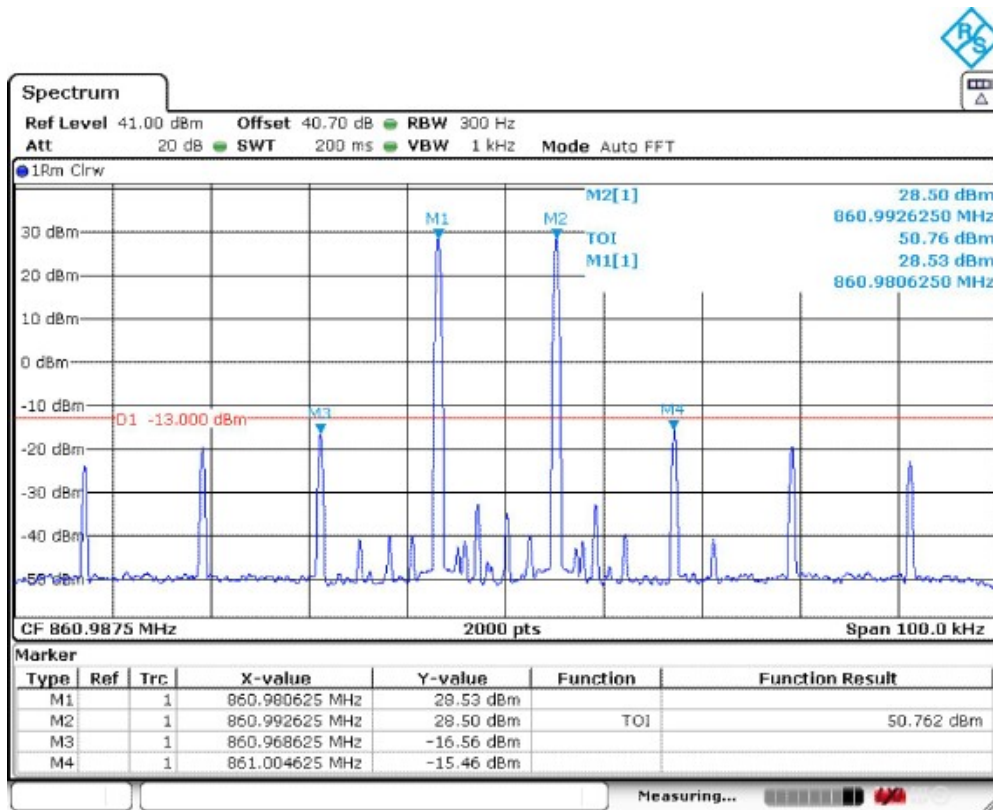

Date: 24.DEC.2022 08:49:10

High Frequency and with the ALC threshold level

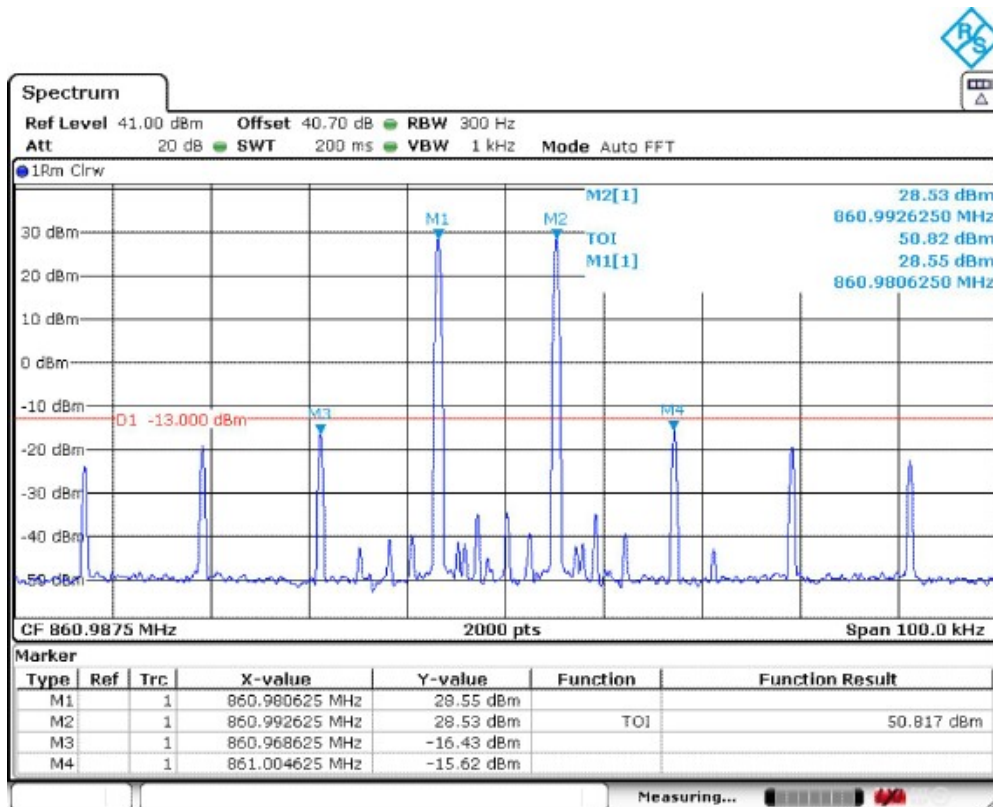

Date: 24.DEC.2022 08:49:18

High Frequency and with the input signal amplitude set 3 dB above the ALC threshold

10.8.5.2.1.2 Uplink

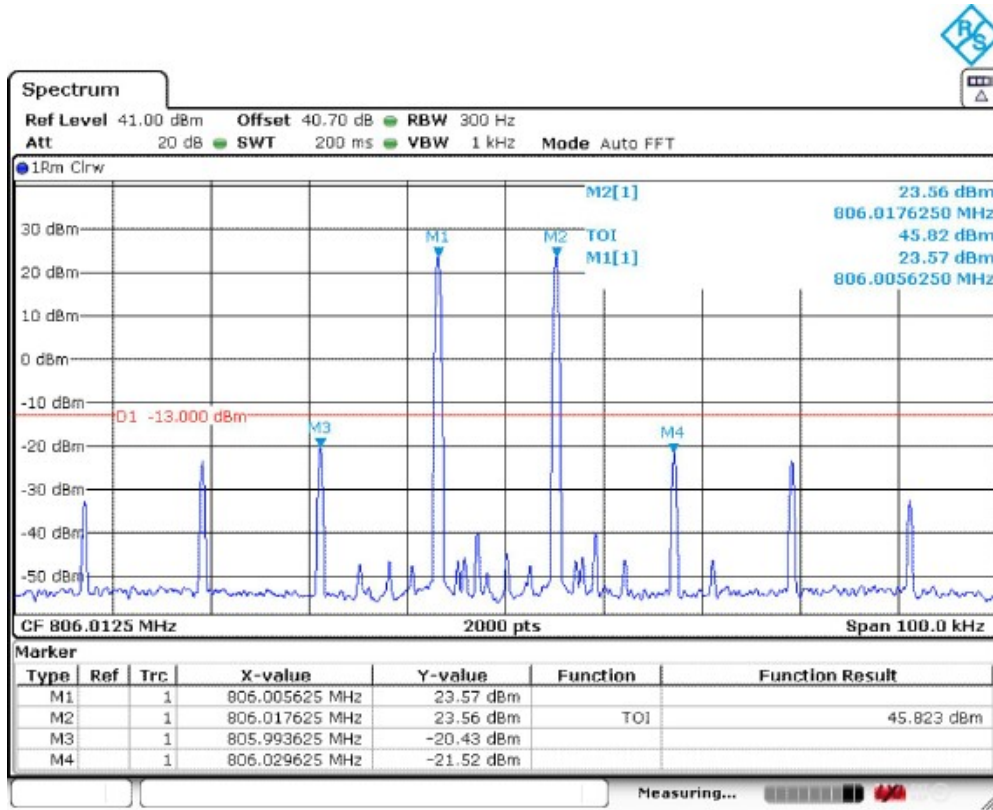

Date: 24.DEC.2022 08:55:56

Low Frequency and with the ALC threshold level

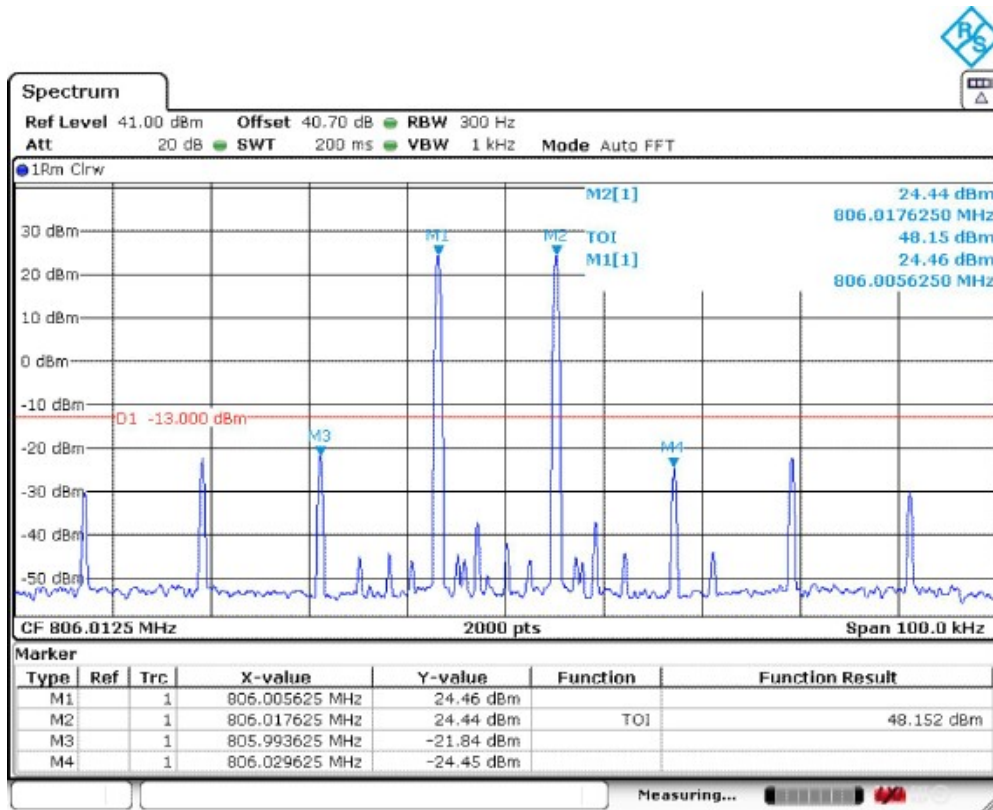

Date: 24.DEC.2022 08:56:03

Low Frequency and with the input signal amplitude set 3 dB above the ALC threshold

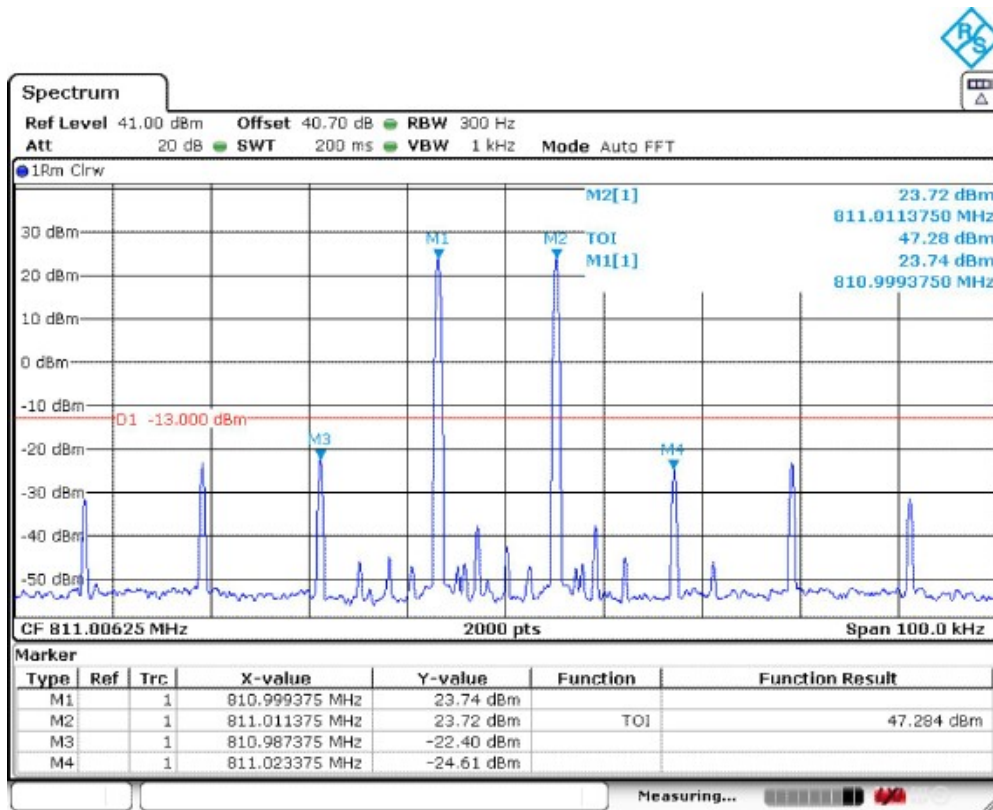

Date: 24.DEC.2022 08:57:00

Mid Frequency and with the ALC threshold level

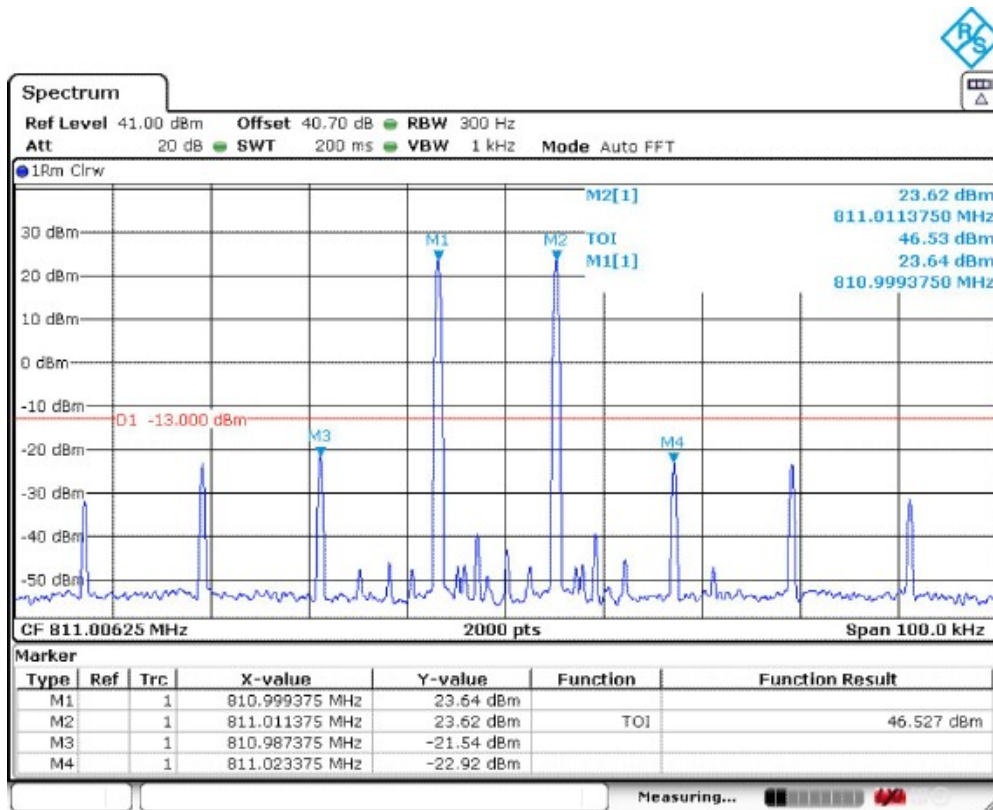

Date: 24.DEC.2022 08:57:06

Mid Frequency and with the input signal amplitude set 3 dB above the ALC threshold

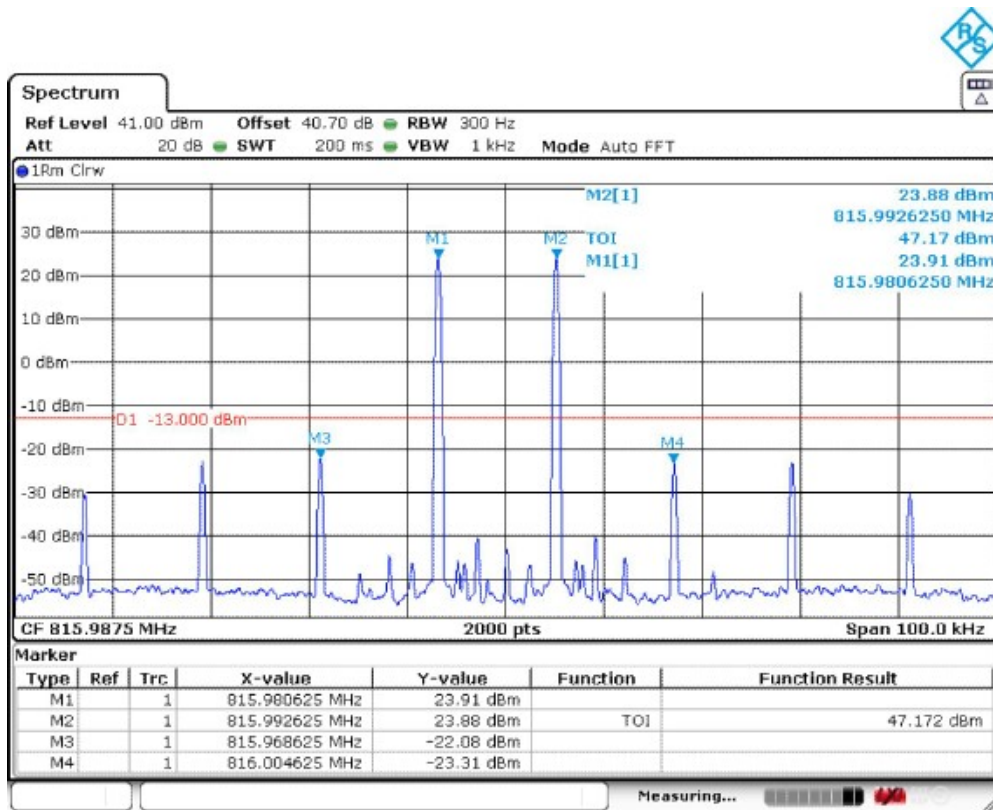

Date: 24.DEC.2022 08:57:56

High Frequency and with the ALC threshold level

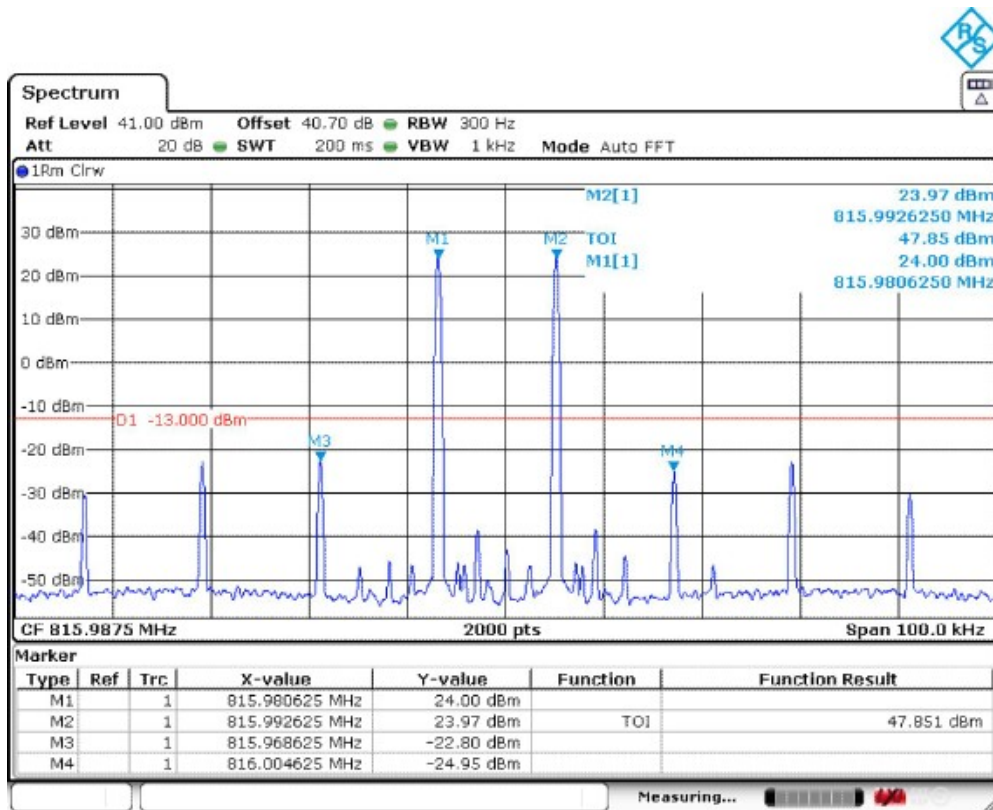

Date: 24.DEC.2022 08:58:06

High Frequency and with the input signal amplitude set 3 dB above the ALC threshold

10.8.5.2.2 Channel bandwidth 25kHz

10.8.5.2.2.1 Downlink

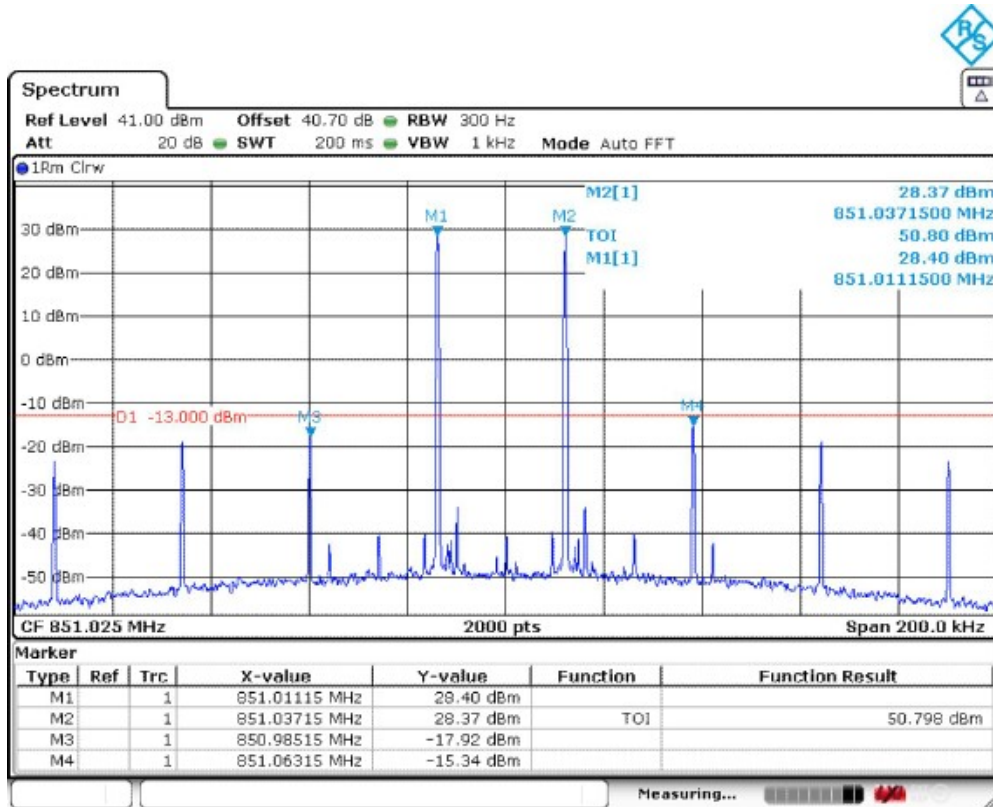

Date: 24.DEC.2022 08:42:59

Low Frequency and with the ALC threshold level

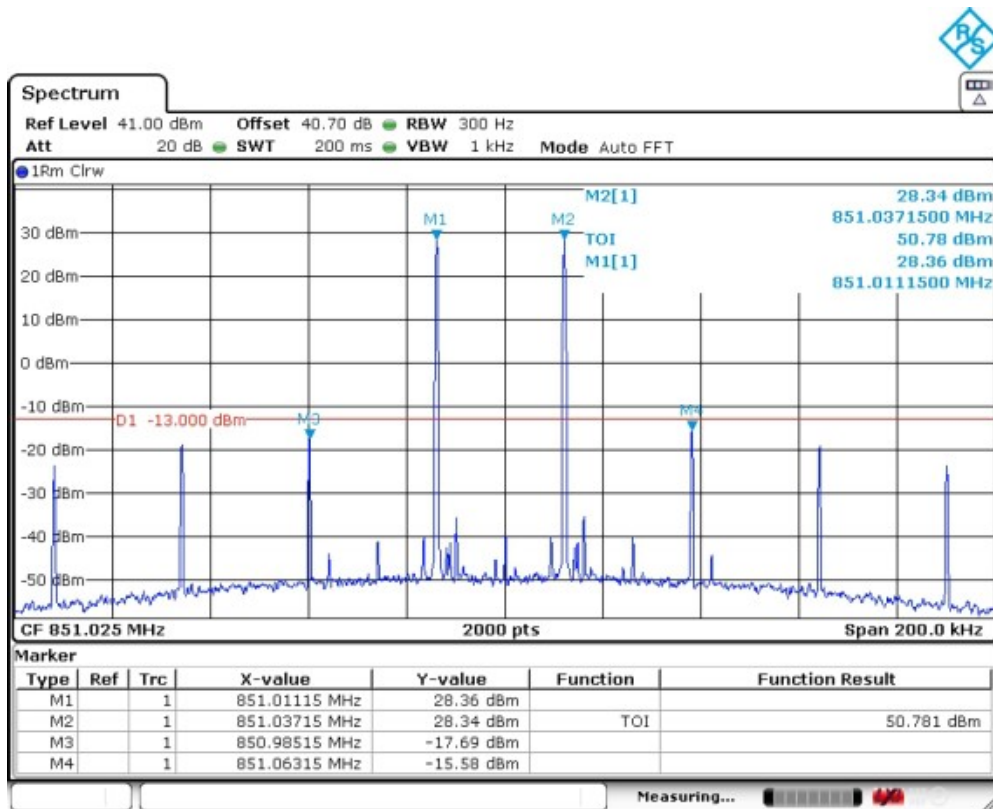

Date: 24.DEC.2022 08:43:22

Low Frequency and with the input signal amplitude set 3 dB above the ALC threshold

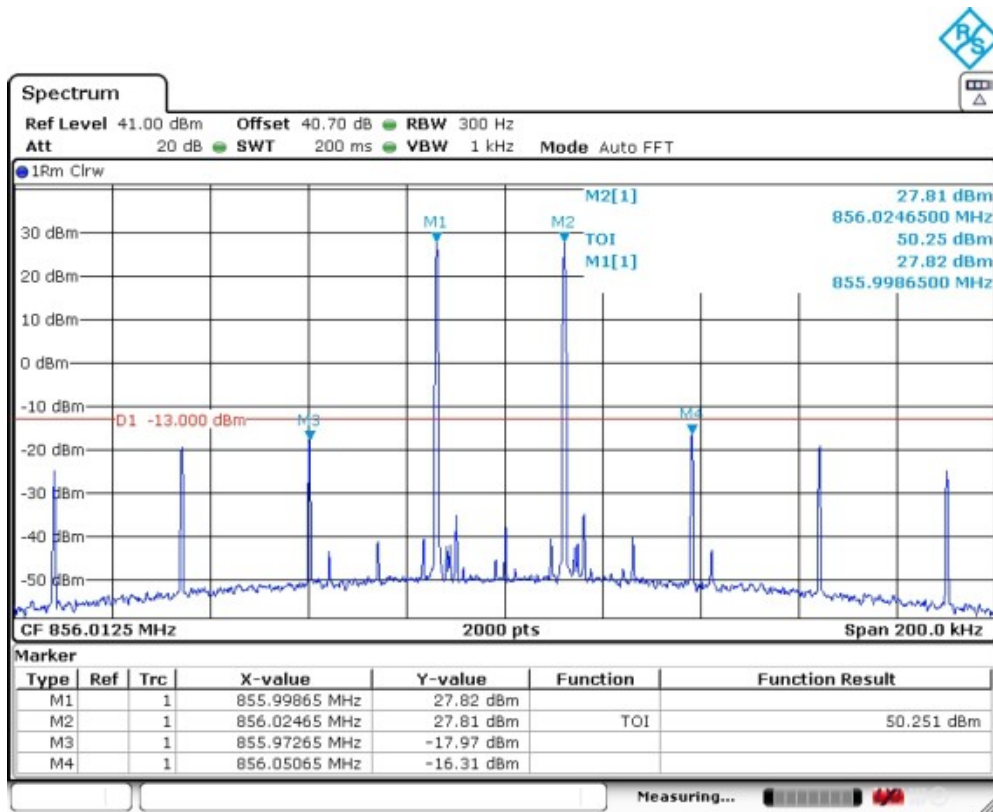

Date: 24.DEC.2022 08:44:03

Mid Frequency and with the ALC threshold level

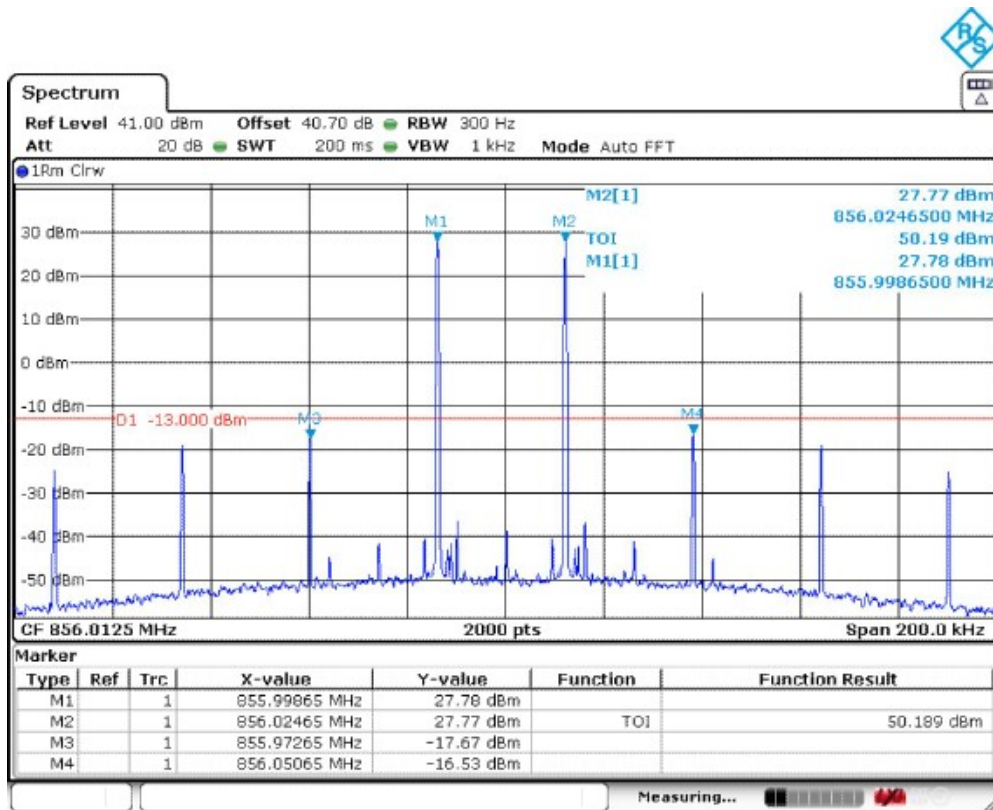

Date: 24.DEC.2022 08:44:26

Mid Frequency and with the input signal amplitude set 3 dB above the ALC threshold

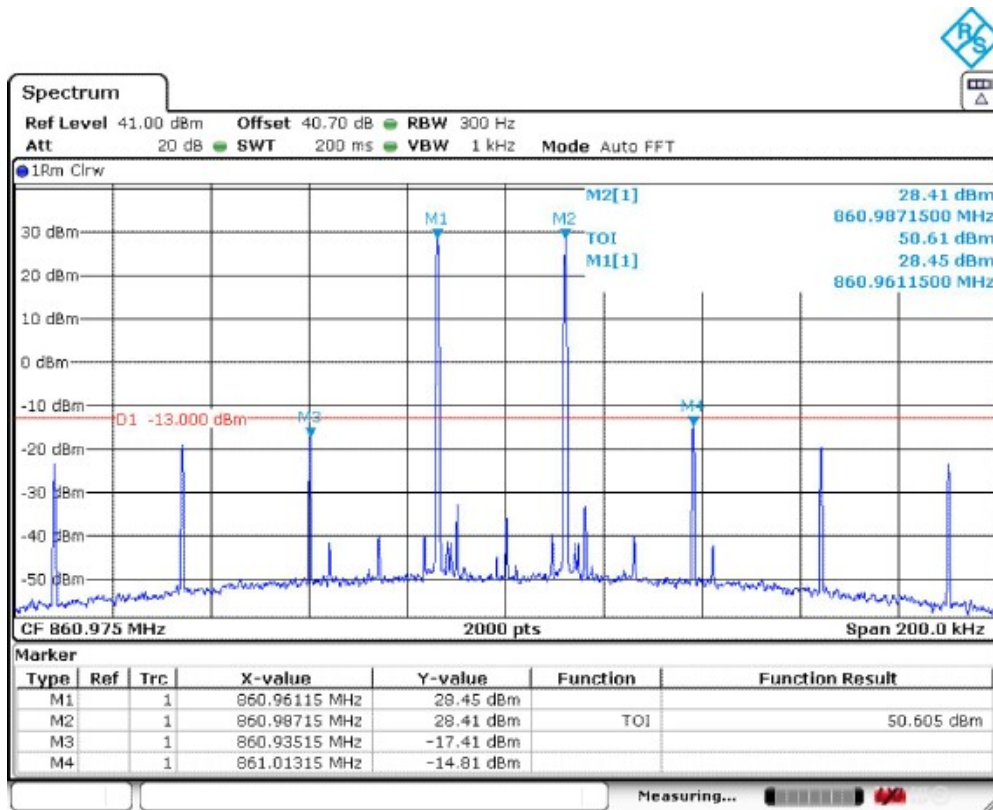

Date: 24.DEC.2022 08:45:11

High Frequency and with the ALC threshold level

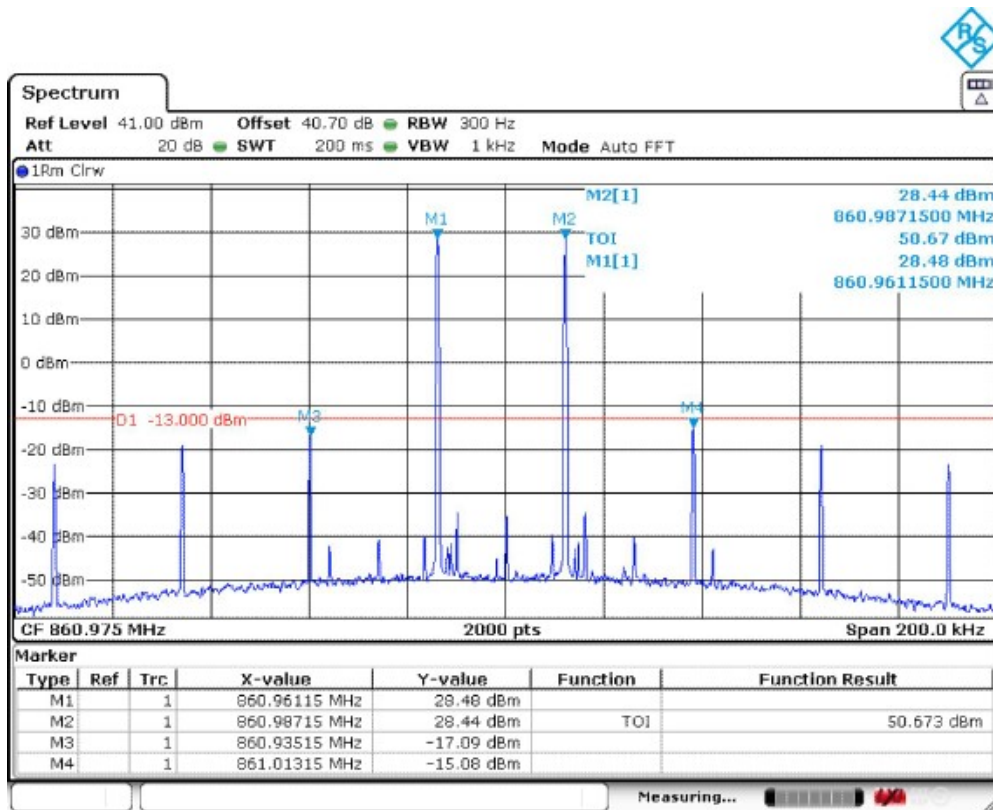

Date: 24.DEC.2022 08:45:18

High Frequency and with the input signal amplitude set 3 dB above the ALC threshold

10.8.5.2.2.2 Uplink

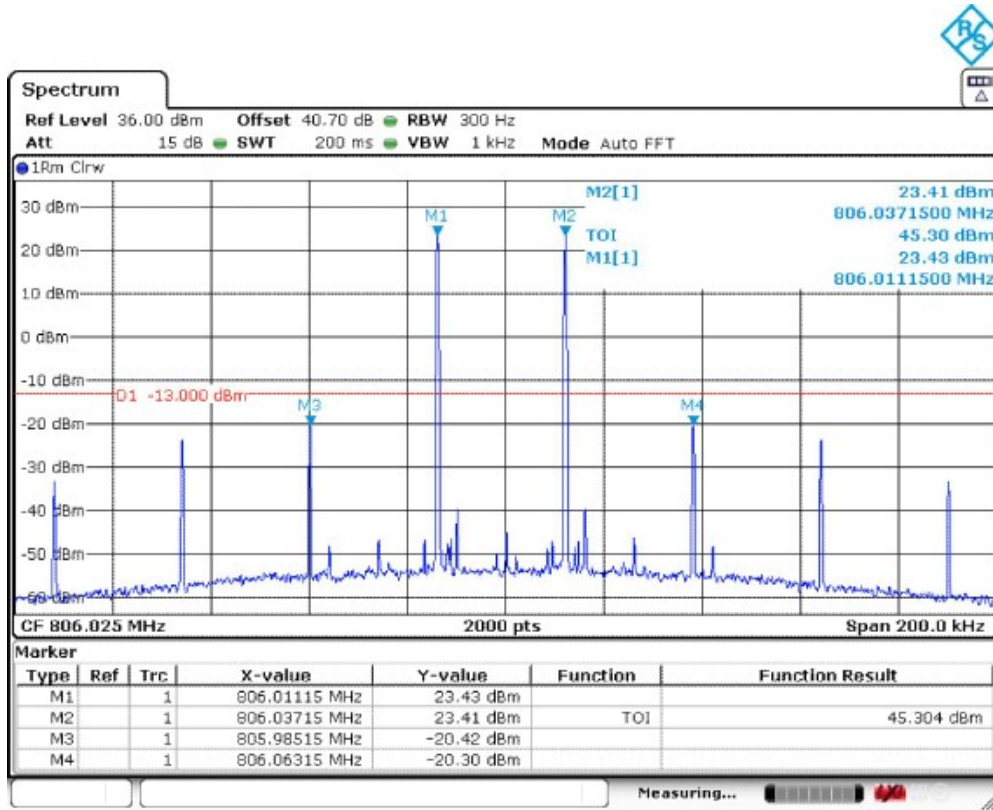

Date: 24.DEC.2022 08:59:28

Low Frequency and with the ALC threshold level

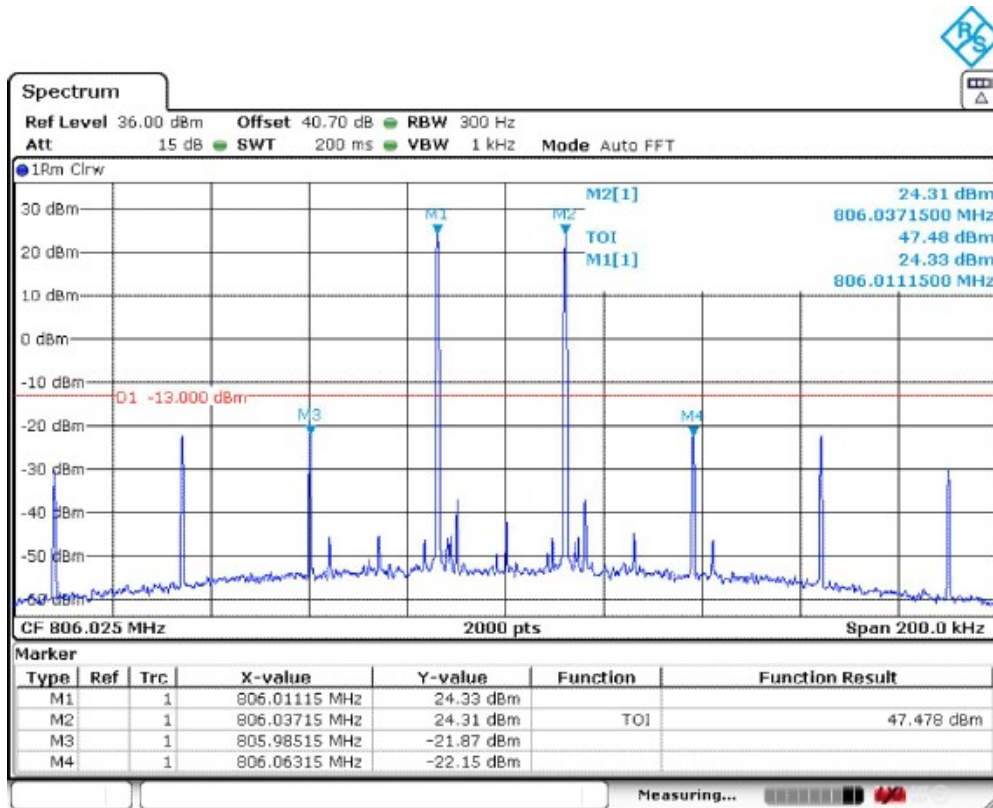

Date: 24.DEC.2022 08:59:56

Low Frequency and with the input signal amplitude set 3 dB above the ALC threshold

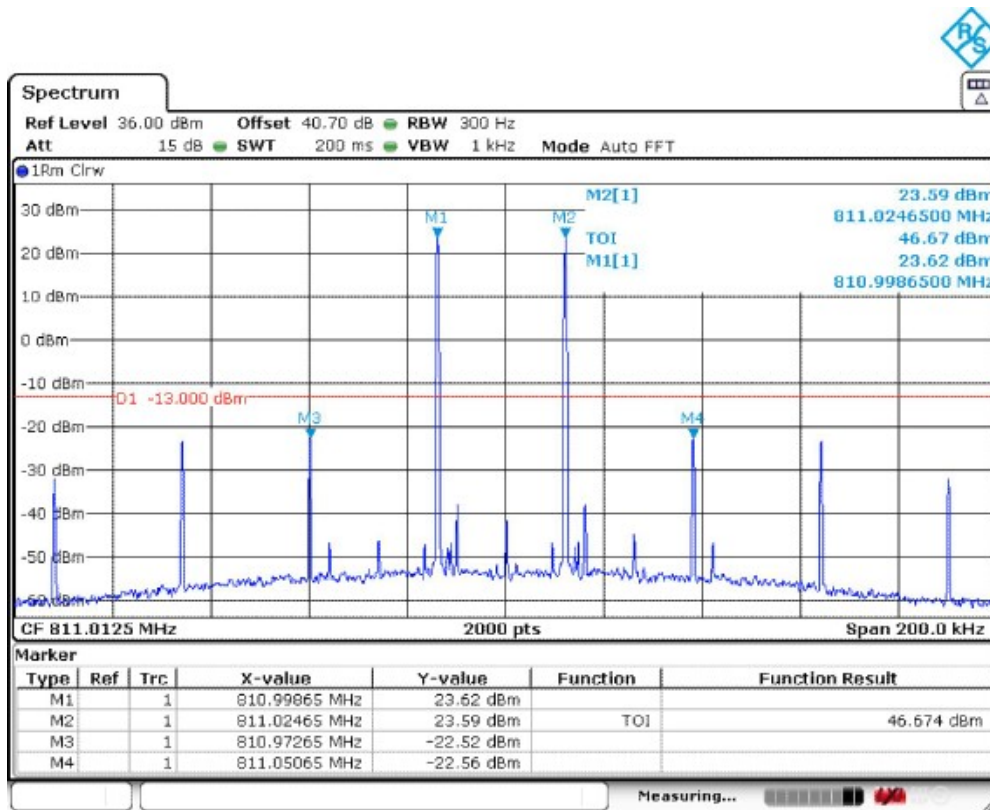

Date: 24.DEC.2022 09:00:42

Mid Frequency and with the ALC threshold level

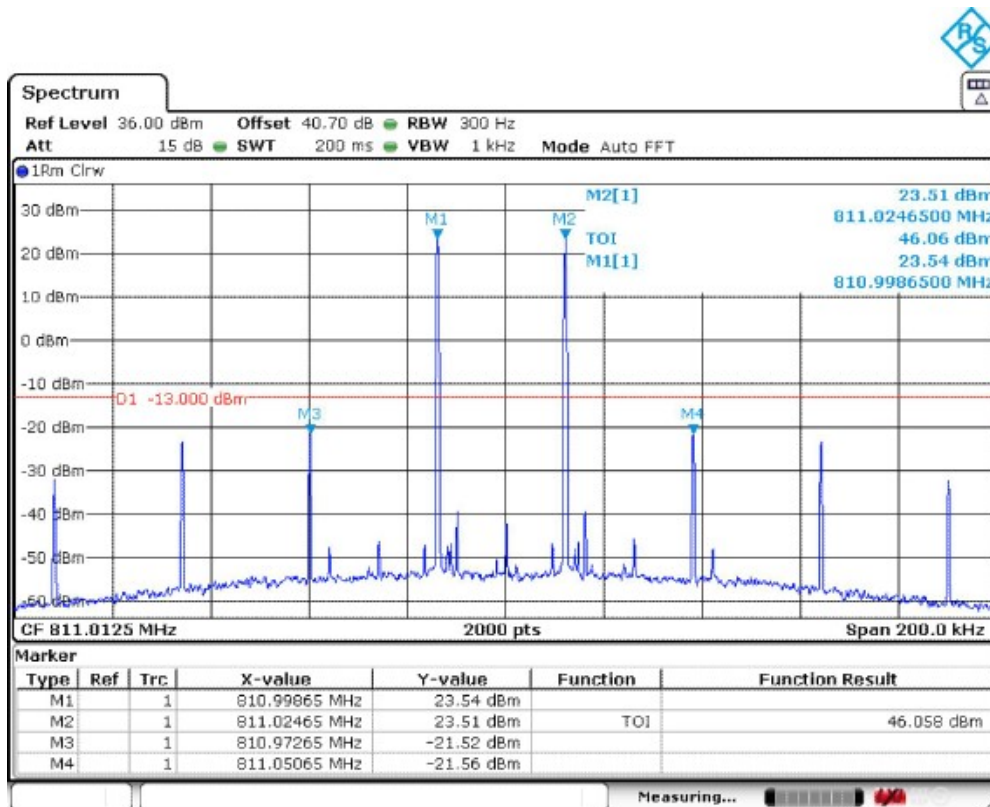

Date: 24.DEC.2022 09:00:49

Mid Frequency and with the input signal amplitude set 3 dB above the ALC threshold