

# AURABEAT

## NSP - W1 Wall Mounted Air Purifier

### User Manual

Thank you for purchasing this air purifier.  
Please read this manual carefully before using.



Aurabeat Technology Limited

 [aurabeat-tech.com](http://aurabeat-tech.com)     +852 26688883

 11H, Golden Bear Industrial, 66-82 Chai Wan Kok Street, Tsuen Wan, N.T., Hong Kong



# Content

1	Important Safety Information	P.2-3
2	Product	P.4
3	Getting Started	P.5-8
4	Using Your Product	P.9-12
5	Care and Maintenance	P.13
6	Troubleshooting	P.14
7	Warranty and Service	P.14
8	After Sales Warranty	P.15-16
9	Specifications	P.17

- Thank you for purchasing this air purifier.
- Please read this manual carefully before using.
- Please read carefully after reading for future reference.

## 1. IMPORTANT SAFETY INFORMATION

Thank you for choosing our products. We are sure you will find your new product is pleasure to use.

**BEFORE USING THIS DEVICE, READ THIS MANUAL CAREFULLY. KEEP THIS MANUAL AND PRODUCT INFORMATION SAFE AND NEARBY FOR FUTURE REFERENCE.**

### Warning

Caution, do not defeat interlock.

Attention, ne pas nuire à l'action du verrouillage de sécurité.

Warning: disconnect power supply before servicing.

Avertissement: couper l'alimentation avant de procéder au dépannage.

Caution: this equipment should be inspected and collector cells should be cleaned in accordance with manufacturer's instructions, on a regular basis to prevent excessive accumulation of dust particles that can result in flashover or a risk of fire.

Attention: cet appareil devrait faire l'OBJET D'UNE inspection et les filtres devraient être nettoyés conformément aux instructions du fabricant, de façon régulière, afin d'empêcher une accumulation excessive de poussière.

Caution: the 8-hour time weighted average (TWA) ozone for this product shall be 0.001PPM when tested in a 30m<sup>3</sup> chamber refer to safety instructions in manual for more information.

Attention: la moyenne pondérée dans le temps (MPT) de 8 heures d'ozone pour ce produit doit être 0.001PPM lorsqu'il est testé dans une chambre de 30m<sup>3</sup>. Reportez-vous aux instructions de sécurité dans le manuel pour plus d'informations.

WARNING : DISCONNECT POWER SUPPLY BEFORE SERVICING

AVERTISSEMENT : COUPER L'ALIMENTATION AVANT DE PROCÉDER AU DÉPANNAGE.

CAUTION : THIS EQUIPMENT SHOULD BE INSPECTED, AND COLLECTOR CELLS SHOULD BE CLEANED IN ACCORDANCE WITH MANUFACTURER'S INSTRUCTIONS, ON A REGULAR BASIS TO PREVENT EXCESSIVE ACCUMULATION OF DUST PARTICLES THAT CAN RESULT IN FLASHOVER OR A RISK OF FIRE

ATTENTION : CET APPAREIL DEVRAIT FAIRE L'OBJET D'UNE INSPECTION ET LES FILTRES DEVRAIENT ÊTRE NETTOYÉS CONFORMÉMENT AUX INSTRUCTIONS DU FABRICANT DE FAÇON RÉGULIÈRE AFIN D'EMPECHER UNE ACCUMULATION EXCESSIVE DE POUSSIÈRE.

CAUTION : THE 8-HOUR TIME WEIGHTED AVERAGE) OZONE FOR THIS PRODUCT SHALL BE

0.001PPM WHEN TESTED IN A 30m<sup>3</sup> CHAMBER REFER TO SAFETY INSTRUCTIONS IN MANUAL FOR MORE INFORMATION.

ATTENTION: LA MOYENNE PONDÉRÉE DANS LE TEMPS) OZONE POUR CE PRODUIT DOIT ÊTRE 0.001PPM LORSQU'IL EST TESTÉ DANS UNE CHAMBRE DE 30m<sup>3</sup>. REPORTEZ-VOUS AUX INSTRUCTIONS DE SÉCURITÉ DANS LE MANUEL POUR PLUS D'INFORMATIONS.

**WARNING!**



## WARNING

We have provided many important safety messages in this manual and on your appliances. Always read and follow all safety messages.

The manufacturer declines any liability for failure to observe these safety instructions, for inappropriate use of the appliance or incorrect setting of controls.

**⚠ This is the safety alert symbol. This symbol alerts you to potential hazards that can kill or hurt you and others.**

All safety messages will tell you what the potential hazard is, tell you how to reduce the chance of injury, and tell you what can happen if the instructions are not followed.

The appliance can only be used safely if it is correctly installed according to the safety instructions.

The appliance is not intended for use outdoors or on wet surfaces.

Do not leave the appliance unattended during operation.

⚠ Very young children (0-3 years) and pets should be kept away from the appliance. Young children (3-8 years) should be kept away from the appliance unless continuously supervised. Children from 8 years old and above and persons with reduced physical, sensory, or mental capabilities or lack of experience and knowledge can use this appliance only if they are supervised or have been given instructions on safe use and understand the hazards involved. Children must not play with the appliance. Cleaning and user maintenance must not be carried out by children without supervision.

⚠ Keep packaging, plastic film and small parts away from children.

## PERMITTED USE AND INSTALLATION

⚠ Connect and operate the appliance only in accordance with the specifications on the rating plate.

⚠ The appliance is not intended to be operated by means of an external switching device, such as a timer, or separate remote-controlled system.

⚠ When installing the appliance, check that the power cord or plug is not trapped or damaged.

⚠ Do not use cord extensions, multiple socket strips nor non-approved adapters.

⚠ Never let the power cord encounter hot appliance parts or hot sources.

⚠ Never let the power cord encounter sharp points or edges.

⚠ Never kink, crush, or modify the power cord.

Turn off and unplug the device to replace filter.

⚠ Do not allow objects to enter, cover or block the air inlets and air outlets.

When unplugging the appliance from the power supply, do not pull on the power cord, pull on the power plug.

Do not alter the power plug in any way.

Do not use the appliance near fire or hot surfaces.

## CLEANING AND MAINTENANCE

⚠ Ensure the appliance is switched off and disconnected from the power supply before performing any maintenance; never use steam cleaning equipment-risk of electric shock.

⚠ Repairs and maintenance can only be carried out by one of our trained after-sales technicians. If the appliance is not working properly, unplug the appliance from the power supply and contact your local after-sales service.

⚠ Do not use abrasive or harsh cleaners such as window sprays, scouring cleansers, flammable fluids, cleaning waxes, concentrated detergents, bleaches, or cleansers containing petroleum products on plastic parts, interior and door liners, or gaskets. Do not use paper towels, scouring pads or other harsh cleaning tools.

## DISPOSAL OF PACKAGING MATERIALS

The packaging material is recyclable and is marked with the recycle symbol .

## 2. PRODUCT

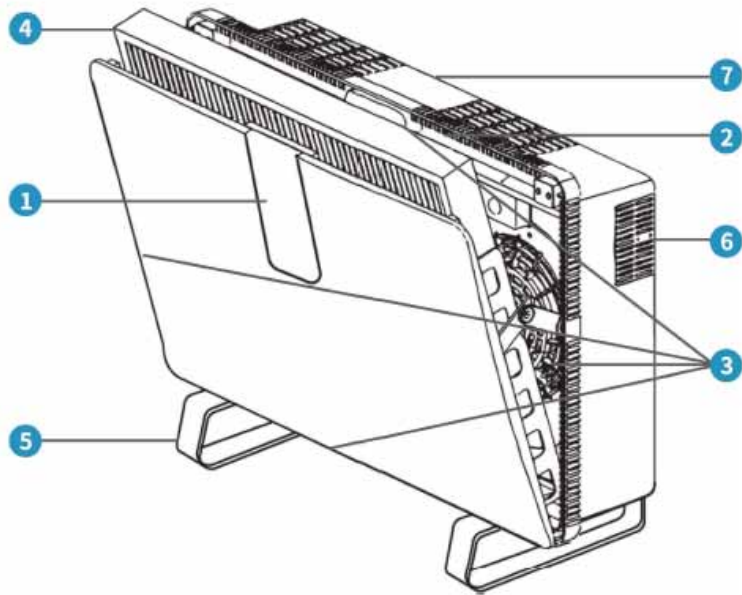

**1** Display & Control Panel

**2** Air Outlet

**3** Air Inlet

**4** Filters

**5** Optional Free Stand Support

**6** Dust Sensor, Temperature Sensor & Humidity Sensor

**7** Removable Wall mounted Accessory

## 3. GETTING STARTED

- a. What's Included
- 1 x Air Purifier
  - 1 x Remote Control
  - 1 x Hybrid Filter
  - 1 x Removable Free Stand
  - 1 x Optional Wall Mounted Bracket
  - 6 x Screws (Dry Wall Type)
  - 6 x Screws (Concrete Wall Type)
  - 1 x User Manual

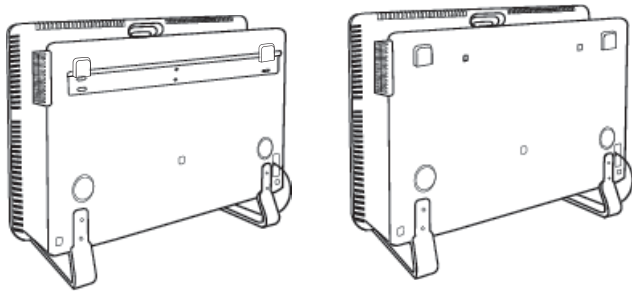

Make sure you remove all packaging for filters and products before using the appliances.

### WALL MOUNTED INSTALLATION

- Find an ideal location to maximize the air cleaning power. The location should be farthest away from the room's HVAC return vent, windows, and doorways.
- Suggested installation height 5 ft from the floor.
- Locate the closest electrical wall outlet.
- It is suggested to install the wall mounted bracket on a concrete wall/dry wall. Mark the position of the screw holes : (6 screw with a pen by the wall bracket supplied).

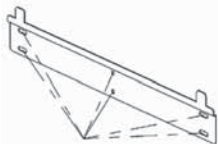

Figure 1

- Drill holes per the screws marked on the wall. Insert plastic mounting into the wall. Mount the supporting bracket on the wall and tighten the screws as shown in the installation diagram (Figure 2) below.

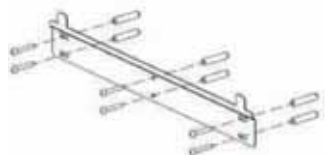

Figure 2

- Install the mounting bracket on the wall.

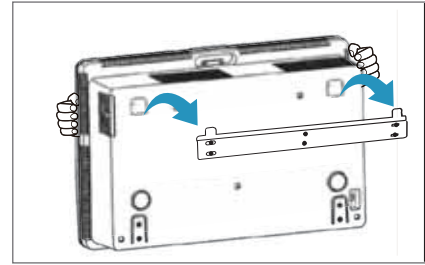

Figure 3

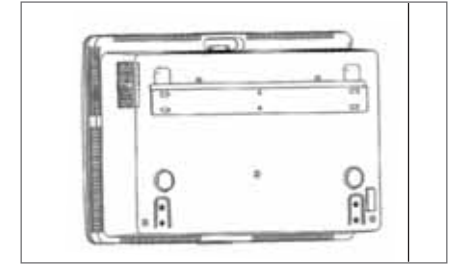

Figure 4

- Mount the appliance on to the bracket.

### FREE STAND INSTALLATION

- Find an ideal location to maximize the air cleaning power. The location should be farthest away from the room's HVAC return vent, windows, and doorways.
- Locate the closest electrical wall outlet.
- Take out the free stand accessories from the package. Tightened the screws provided as shown in below installation diagram. (Figure 5)

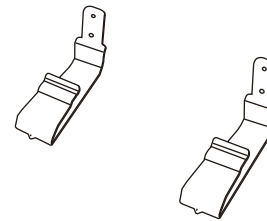

Figure 5

- Tightened the 4 screws provided at the back (as shown in figure 6) and installation is completed.

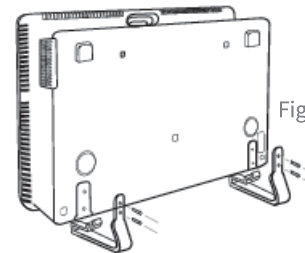

Figure 6

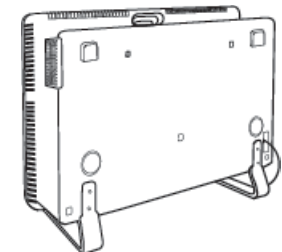
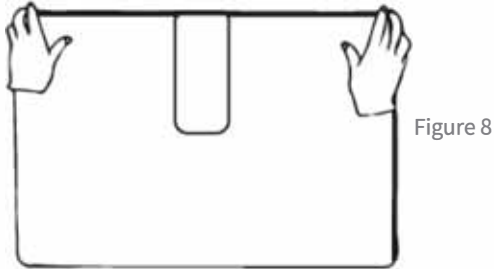

Figure 7

## FILTER INSTALLATION

- a. Open the front panel with 2 hands.



- b. Take out the filter and remove the packages.

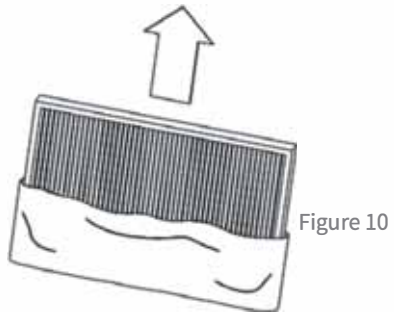
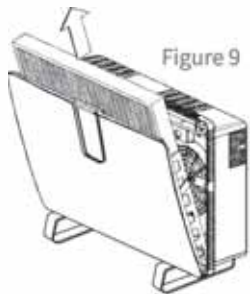

- c. Put the filter back into the air purifier and close the front panel with 2 hands.

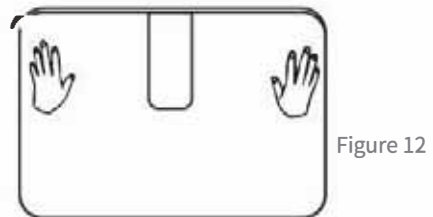
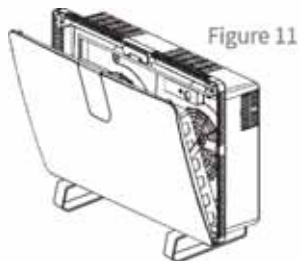

- d. Take out the supplied power cord and plug in to the power supply.

## WI-FI APPS CONNECTION

- a. Download the apps from the APPS store/ google play
- b. Press and hold the Wi-Fi icon for 5 seconds until you hear the sound to activate this function. The Wi-Fi logo will be on once the function is activated.
- c. If the APPS is not activated successfully within 3 minutes, please deactivate the Wi-Fi function, and retry again for the APPS connection.

## 4. USING YOUR PRODUCT

### (i) Control Panel

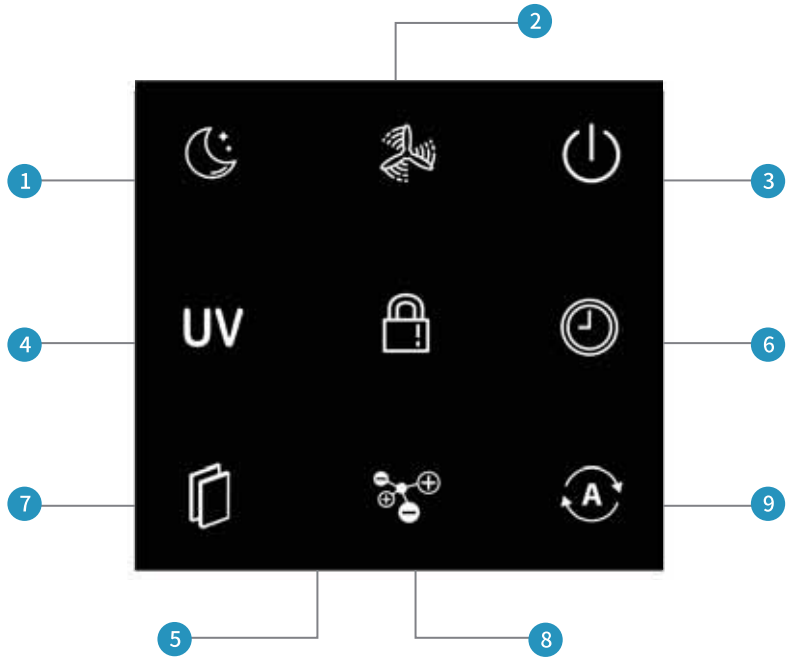



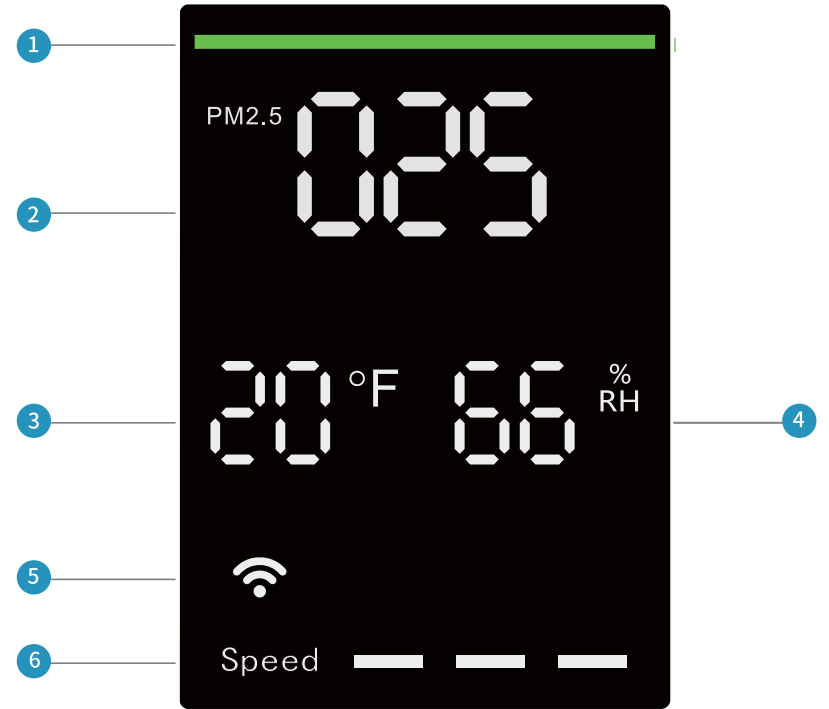





- 1 Sleep Mode
- 2 Fan Speed
- 3 Power
- 4 UV
- 5 Child Lock
- 6 Timer
- 7 Filter Replacement
- 8 Plasma
- 9 Auto Mode



- 1 Air Quality Indicator  
(1-79 = Green; 80-199 = Yellow; >200 = Red)
- 2 PM2.5 Indicator
- 3 Temperature
- 4 Humidity
- 5 Wi-Fi
- 6 Fan Speed

## Operating Instructions

Icon	Function	Function Details												
	Power	<ol style="list-style-type: none"> <li>1. Press the power button to turn on/turn off the product.</li> <li>2. The “On/Off”, “Auto”, “PM2.5”, “Temp”, “Humidity” indicators will be on once product is turned on.</li> </ol>												
	Fan Speed/ Intelligent Mode	<ol style="list-style-type: none"> <li>1. Adjust the fan speed from 1 to 3 by pressing the button.</li> <li>2. The fan speed indicator will be on if the fan speed function is activated.</li> </ol>												
	Intelligent Mode	<ol style="list-style-type: none"> <li>1. Press [AUTO] button and the machine will turn into the intelligent mode. The fan speed can be adjusted according to the air quality. Details as below: <table border="1" data-bbox="472 689 1034 791"> <thead> <tr> <th>Air Quality Indicator Light</th> <th>Green</th> <th>Yellow</th> <th>Red</th> </tr> </thead> <tbody> <tr> <td>Fan Speed Indicator</td> <td>Auto</td> <td>Auto</td> <td>Auto</td> </tr> <tr> <td>Fan Speed</td> <td>Low</td> <td>Middle</td> <td>High</td> </tr> </tbody> </table> </li> <li>2. Repress [AUTO] button and the Auto mode will be deactivated.</li> </ol>	Air Quality Indicator Light	Green	Yellow	Red	Fan Speed Indicator	Auto	Auto	Auto	Fan Speed	Low	Middle	High
Air Quality Indicator Light	Green	Yellow	Red											
Fan Speed Indicator	Auto	Auto	Auto											
Fan Speed	Low	Middle	High											
	Timer	<ol style="list-style-type: none"> <li>1. Press “Timer” button to set the timer on function, from 1 to 24 hours.</li> </ol>												
	Filter Replacement Reminder	<ol style="list-style-type: none"> <li>1. The replacement indicator will be on after working for 4320 hours to remind you for filter replacement.</li> <li>2. To reset the reminder, press and hold the button for 3 seconds to rest the alarm and an “acoustic” sound will be heard to confirm.</li> </ol>												
	Child Lock	<ol style="list-style-type: none"> <li>1. Press and hold the button for 3 seconds to activate this function.</li> <li>2. To de-activate this function, press and hold the button for 3 seconds.</li> </ol>												
	Plasma	<ol style="list-style-type: none"> <li>1. Press and hold this button to activate this function.</li> <li>2. Press and hold this button to de-activate this function.</li> </ol>												

Icon	Function	Function Details
	Sleep Mode	<ol style="list-style-type: none"> <li>1. Press the button to activate this function. The appliance will start to work at the lowest speed with UV and plasma kept at the previous setting.</li> <li>2. Timer function is disabled.</li> </ol>
	UV Light	Press the "UV light" button once to turn it on and press again to turn it off
	Standby Mode	Once the product is connected, an acoustic sound will be heard to confirm. The control panel will be on for 2s and product is under standby mode.
	Auto Mode (or Light Sensor Mode)	<p>Press the "Auto" once to turn on this function.</p> <ol style="list-style-type: none"> <li>1. Under Auto mode, the appliance will be on under the sleep mode if the environment is dark.</li> <li>2. If the environment is lighted, the appliance will turned on to the highest level with plasma on for 10 minutes to sterilize and return to sleep mode afterwards.</li> </ol>



## 5. CARE AND MAINTENANCE

### Note

- Never immerse the appliance in water or any other liquid.

### Cleaning

- Never use abrasive, aggressive or flammable cleaning agents to clean any part of the appliances as these agents may damage the air purifier. Do not wash the main filter with any liquid (including water). It is not washable.

### Cleaning

- Wipe the exterior and air outlet of the air purifier with a soft, clean, damp cloth.
- Open the front door, clean the inside of the air purifier with a soft, clean cloth.

### Cleaning Schedule

Frequency	Cleaning method
When necessary	<ul style="list-style-type: none"> <li>Wipe the plastic components of the appliance with a soft and dry cloth</li> <li>Clean or vacuum the air outlet</li> </ul>
Every two months	<ul style="list-style-type: none"> <li>Clean the dust sensor with a soft brush</li> </ul>
The  displays on the screens	<ul style="list-style-type: none"> <li>Replace the filter</li> </ul>

### Air Quality Sensor

Recommended to clean the sensor every 2 months or when necessary for optimal functioning of the air purifier.

- 1) Pull out the protective cover located on the upper right. Please refer to below drawing for reference.

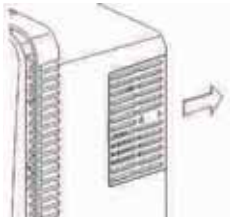

- 2) Clean the sensor with a damp cotton swab and make sure that the sensor is dry before closing the protective cover.

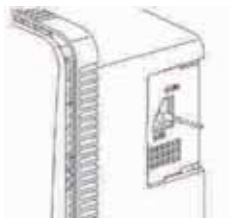

## 6. TROUBLESHOOTING

Problem	Symptoms	Recommended Solution
<b>The appliance is not working</b>	The product is not connected.	Please make sure that the power cord is connected to power supply.
<b>The air outflow is significantly weaker than before</b>	The air inlet is covered.	Ensure that the air inlet is not blocked.
	The surface of the filter is dirty.	Clean the air inlet.
		Clean the surface of the air filter.
<b>The air outflow is significantly stronger than before</b>	The filter is not installed correctly.	Please install the filter correctly.
	The filter is damaged.	Replace a new filter.
<b>Product is very noisy during operation</b>	The air inlet is covered.	Please remove the objects covering the air inlet.
	There is object within the air outlet.	Please clean the air outlet.

## 7. WARRANTY AND SERVICE

- 1 After the free warranty, you can contact the company to provide maintenance service.
- 2 Following conditions are not covered by the warranty:
  - a) Damage due to man-made factors
  - b) Damage due to unauthorized disassembly or repair
  - c) Normal wear and tear after usage
  - d) Filter (unless the filter was damaged before used)
  - e) Damage due to improper installation and usage

## 8. After-sales Warranty

### WARRANTY

Aurabeat North America products are backed by some of the most comprehensive warranties in the industry. Aurabeat North America warrants that the Aurabeat Wall Mounted Air Purifier shall be free from defects in material and workmanship under normal use and service.

Residential & Commercial Warranty for Aurabeat Wall Mounted Sanitizing Air Purifier – 3-year limited warranty

Includes Base Model numbers: NSP-W1

100% Coverage of defects or malfunctions of all electronic parts and labor for the entire product excluding consumable filters for the first three years from original date of purchase.

#### Exclusions and Limitations

1. Aurabeat North America warrants its products to be free from manufacturing defects under normal use and service. This warranty is extended only to the ORIGINAL PURCHASER.

2. Aurabeat North America's obligations under this warranty are limited to repairs or replacement, at Aurabeat North America's option, of products or parts found to be defective, provided that such products were properly installed and used in accordance with instructions. Aurabeat North America reserves the right to make such inspections as may be necessary in order to determine the cause of the defect. Aurabeat North America will not charge for labor or parts in connection with warranty repairs for the first three years from date of purchase on all products except those that may be subject to heavy commercial use limitations.

3. Aurabeat North America is not responsible for the cost of removal, return (shipping) and/or reinstallation of products. This warranty does NOT apply to:

- Damage or loss which occurs during shipment.
- Damage or loss sustained through any natural or man-made causes beyond the control of Aurabeat North America, including but not limited to fire, earthquake, floods, etc.
- Damage or loss resulting from negligent or improper installation including installation of a unit in a harsh or excessively hazardous environment.
- Damage or loss resulting from removal, improper repair, modification of the product, or improper maintenance including damage caused by improper cleaning and exchanging of filters
- Damage or loss resulting from acts which are not the fault of Aurabeat North America or which the Product is not specified to tolerate.
- Normal wear and tear usage on the appliance or damages and wear to the filter during use or maintenance.

4. This warranty gives you specific legal rights. You may have other rights which vary from state to state.

THIS WRITTEN WARRANTY IS THE ONLY WARRANTY MADE BY AURABEAT NORTH AMERICA. REPAIR OR REPLACEMENT AS PROVIDED UNDER THIS WARRANTY SHALL BE THE EXCLUSIVE REMEDY AVAILABLE TO THE PURCHASER. AURABEAT NORTH AMERICA SHALL NOT BE RESPONSIBLE FOR LOSS OF USE OF THE PRODUCT OR FOR OTHER INCIDENTAL, SPECIAL, OR CONSEQUENTIAL DAMAGES OR EXPENSES INCURRED BY THE PURCHASER OR FOR LABOR OR OTHER COSTS DUE TO INSTALLATION OR REMOVAL OR COSTS OF REPAIRS BY OTHERS, OR FOR ANY OTHER EXPENSE NOT SPECIFICALLY STATED ABOVE. EXCEPT TO THE EXTENT PROHIBITED BY APPLICABLE LAW, ANY IMPLIED WARRANTIES, INCLUDING THAT OF MERCHANTABILITY, ARE EXPRESSLY LIMITED TO THE DURATION OF THIS WARRANTY. SOME STATES DO NOT ALLOW LIMITATIONS, SO THE ABOVE LIMITATION AND EXCLUSION MAY NOT APPLY TO YOU.

#### How to Obtain Service

To obtain repair service under this warranty, you must contact an authorized Aurabeat North America or Brondell Service Center to obtain an RMA (Return Merchandise Authorization) number. Proof of purchase in the form of a copy of the original receipt must accompany the returned unit for the warranty to be valid. Take or ship the unit pre-paid to the closest Aurabeat North America or Brondell authorized service center along with the RMA number and proof of purchase. To obtain an RMA number, contact the Brondell Service Center at 1-888-542-3355 or by email [support@brondell.com](mailto:support@brondell.com) or Aurabeat North America by email [support@aurabeat-us.com](mailto:support@aurabeat-us.com)

## 10. TECHNICAL SPECIFICATIONS

Item	Specifications
Model No.	NSP-W1
Voltage	220V ~ 50Hz
Rating Power	85W
Recommend Coverage	30-40m <sup>2</sup>
CADR	360 m <sup>3</sup> /h
Noise Level	50dB
Machine size	23.6*8.4*17.2inch (Free Standing) 23.6*6.6*15.9inch(Wall-mounted)

## FCC Warning

This device complies with part 15 of the FCC Rules. Operation is subject to the following two conditions:  
(1) This device may not cause harmful interference, and (2) this device must accept any interference received, including interference that may cause undesired operation.

Any Changes or modifications not expressly approved by the party responsible for compliance could void the user's authority to operate the equipment.

**Note:** This equipment has been tested and found to comply with the limits for a Class B digital device, pursuant to part 15 of the FCC Rules. These limits are designed to provide reasonable protection against harmful interference in a residential installation. This equipment generates uses and can radiate radio frequency energy and, if not installed and used in accordance with the instructions, may cause harmful interference to radio communications. However, there is no guarantee that interference will not occur in a particular installation. If this equipment does cause harmful interference to radio or television reception, which can be determined by turning the equipment off and on, the user is encouraged to try to correct the interference by one or more of the following measures:

- Reorient or relocate the receiving antenna.
- Increase the separation between the equipment and receiver.
- Connect the equipment into an outlet on a circuit different from that to which the receiver is connected.
- Consult the dealer or an experienced radio/TV technician for help.

This equipment complies with FCC radiation exposure limits set forth for an uncontrolled environment. This equipment should be installed and operated with minimum distance 20cm between the radiator & your body.