

	Spectrum Research & Testing Lab., Inc. No.167, Ln. 780, Shan-Tong Rd., Ling 8, Shan-Tong Li, Chung-Li Dist., Taoyuan City 320, Taiwan (R.O.C.)	<h1>TEST REPORT</h1>	Reference No. : A20092502 Report No. : FCCA20092502 FCC ID : 2AXURX5003 Page : 1 of 34 Date : JAN. 02, 2021
---	--	----------------------	---

Product Name: DASH CAM
 Model No.: X5003
 Applicant: MASI AUTO Co., LTD..
 7F-10, No.9, Sec. 2, Nankan Rd., Luzhu Dist., Taoyuan City 338, Taiwan
 Date of Receipt: Sep. 15, 2020
 Finished date of Test: Oct. 13, 2020
 Applicable Standards: 47 CFR Part 15, Subpart C, 15.247
 ANSI C63.10: 2013

We, **Spectrum Research & Testing Laboratory Inc.**, hereby certify that one sample of the above was tested in our laboratory with positive results according to the above-mentioned standards. The records in the report are an accurate account of the results. Details of the results are given in the subsequent pages of this report.

Tested By : David Hung , Date: 01/02/2021
 (David Hung)

Approved By : J. Ho , Date: 1/2/2021
 (Johnson Ho, Director)





Spectrum Research & Testing Lab., Inc.

No.167, Ln. 780, Shan-Tong Rd., Ling 8, Shan-Tong Li, Chung-Li Dist., Taoyuan City 320, Taiwan (R.O.C.)

TEST REPORT

Reference No. : A20092502
Report No. : FCCA20092502
FCC ID : 2AXURX5003
Page : 2 of 34
Date : Jan. 02, 2021

Revisions History

Report No.	Issue Date	Revisions
FCCA20092502	Jan. 02, 2021	Initial issue



Table of Contents

1. DOCUMENT POLICY AND TEST STATEMENT	5
1.1 DOCUMENT POLICY	5
1.2 TEST STATEMENT	5
1.3 EUT MODIFICATION	5
2. DESCRIPTION OF EUT AND TEST MODE	6
2.1 GENERAL DESCRIPTION OF EUT	6
2.2 DESCRIPTION OF EUT INTERNAL DEVICE.....	6
2.3 DESCRIPTION OF TEST MODE	7
2.4 EUT OPERATING CONDITION	7
2.5 DESCRIPTION OF SUPPORT UNIT	8
2.6 CHANNEL AND FREQUENCY TABLE	8
3. DESCRIPTION OF APPLIED STANDARDS	9
3.1 DESCRIPTION OF APPLIED KDB.....	9
3.2 SUMMARY OF TEST RESULTS.....	9
4. TECHNICAL CHARACTERISTICS TEST	10
4.1 CONDUCTED EMISSION TEST	10
4.1.1 LIMIT	10
4.1.2 TEST EQUIPMENT	10
4.1.3 TEST SETUP	11
4.1.4 TEST PROCEDURE	11
4.1.5 TEST RESULT	11
4.2 RADIATED EMISSION TEST	12
4.2.1 LIMIT	12
4.2.2 TEST EQUIPMENT	13
4.2.3 TEST SET-UP	14
4.2.4 TEST PROCEDURE	15
4.2.5 TEST RESULT	16
4.3 BANDWIDTH TEST	19
4.3.1 LIMIT	19
4.3.2 TEST EQUIPMENT	19
4.3.3 TEST SET-UP	19
4.3.4 TEST PROCEDURE	19
4.3.5 EUT OPERATING CONDITION	19
4.3.6 TEST RESULT	20
4.4 PEAK CONDUCTED OUTPUT POWER TEST	22
4.4.1 LIMIT	22
4.4.2 TEST EQUIPMENT	22
4.4.3 TEST SET-UP	22
4.4.4 TEST PROCEDURE	22
4.4.5 EUT OPERATING CONDITION.....	22
4.4.6 TEST RESULT	23
4.5 BAND EDGE TEST.....	24
4.5.1 LIMIT	24
4.5.2 TEST EQUIPMENT	25



Spectrum Research & Testing Lab., Inc.

No.167, Ln. 780, Shan-Tong Rd., Ling 8, Shan-Tong Li, Chung-Li Dist., Taoyuan City 320, Taiwan (R.O.C.)

TEST REPORT

Reference No. : A20092502
Report No. : FCCA20092502
FCC ID : 2AXURX5003
Page : 4 of 34
Date : Jan. 02, 2021

4.5.3	TEST SETUP	26
4.5.4	TEST PROCEDURE	26
4.5.5	EUT OPERATING CONDITION	27
4.5.6	TEST RESULT	28
4.6	POWER SPECTRAL DENSITY TEST	31
4.6.1	LIMIT	31
4.6.2	TEST EQUIPMENT	31
4.6.3	TEST SET-UP	31
4.6.4	TEST PROCEDURE	31
4.6.5	EUT OPERATING CONDITION	31
4.6.6	TEST RESULT	32
5.	ANTENNA APPLICATION	33
5.1	ANTENNA REQUIREMENT	33
5.2	RESULT	33
6.	TERMS OF ABBREVIATION	34



Spectrum Research & Testing Lab., Inc.

No.167, Ln. 780, Shan-Tong Rd., Ling 8, Shan-Tong Li, Chung-Li Dist., Taoyuan City 320, Taiwan (R.O.C.)

TEST REPORT

Reference No. : A20092502
Report No. : FCCA20092502
FCC ID : 2AXURX5003
Page : 5 of 34
Date : Jan. 02, 2021

1. DOCUMENT POLICY AND TEST STATEMENT

1.1 DOCUMENT POLICY

- The report shall not be reproduced except in full, without the written approval of SRT Lab, Inc.
- FCC Registered Test Site Number : TW1016

1.2 TEST STATEMENT

- The test results in the report apply only to the unit tested by SRT Lab.
- There was no deviation from the requirements of test standards during the test.
- DC power source, DC 3V of button cell battery or DC 12V from car charger, was used during the test.

1.3 EUT MODIFICATION

- No modification in SRT Lab.

**Spectrum Research & Testing Lab., Inc.**

No.167, Ln. 780, Shan-Tong Rd., Ling 8, Shan-Tong Li, Chung-Li Dist., Taoyuan City 320, Taiwan (R.O.C.)

TEST REPORTReference No. : A20092502
Report No. : FCCA20092502
FCC ID : 2AXURX5003
Page : 6 of 34
Date : Jan. 02, 2021**2. DESCRIPTION OF EUT AND TEST MODE****2.1 GENERAL DESCRIPTION OF EUT**

PRODUCT	DASH CAM
MODEL NO.	X5003
POWER SUPPLY	DC power source, DC 3V from battery of DC 12V from car charger
CABLE	NA
FREQUENCY BAND	2400 MHz ~ 2483.5 MHz
CARRIER FREQUENCY	2412 MHz
NUMBER OF CHANNEL	802.11g_CH01 : 2412 MHz
RATED RF OUTPUT POWER	-9.12 dBm (0.12 mW)
MODULATION TYPE	IEEE802.11g OFDM(BPSK/16-QAM/64-QAM)
MODE OF OPERATION	Duplex
NUMBER OF CHANNELS	1
ANTENNA TYPE	Chip Antenna (Brand : RainSun Model : AN1003)
ANTENNA GAIN	1.5 dBi

NOTE:

For more detailed information, please refer to the EUT's specification or user's manual provided by manufacturer.

2.2 DESCRIPTION OF EUT INTERNAL DEVICE

DEVICE	BRAND / MAKER	MODEL #	FCC ID / DOC	REMARK
Car charger	MASI	X5003	N/A	3.5m shielded power cable
Camera cable	MASIGO	X5003	N/A	7.0m shielded signal cable
Button cell battery	Seiko Instruments Inc	MS621FE	N/A	3 V 5.5mAh



Spectrum Research & Testing Lab., Inc.

No.167,Ln. 780, Shan-Tong Rd.,Ling 8, Shan-Tong Li, Chung-Li Dist., Taoyuan City 320, Taiwan (R.O.C.)

TEST REPORT

Reference No. : A20092502
Report No. : FCCA20092502
FCC ID : 2AXURX5003
Page : 7 of 34
Date : Jan. 02, 2021

2.3 DESCRIPTION OF TEST MODE

There are test modes for each test configuration as below:

	Mode	Channel	Frequency (MHz)
01	802.11g	CH01	2412

NOTE:

1. Below 1 GHz were pre-tested in chamber and chosen the worst case for conducted and radiated emission test.
2. Above 1 GHz were tested individually.
3. The axis X,Y and Z we evaluate in chamber, the X axis is worst case.

2.4 EUT OPERATING CONDITION

1. For use customer provided continuous transmission EUT.
2. Turn on the power of all equipment and EUT.
3. Set the EUT under continuous transmission condition.

**Spectrum Research & Testing Lab., Inc.**

No.167, Ln. 780, Shan-Tong Rd., Ling 8, Shan-Tong Li, Chung-Li Dist., Taoyuan City 320, Taiwan (R.O.C.)

TEST REPORT

Reference No. : A20092502
Report No. : FCCA20092502
FCC ID : 2AXURX5003
Page : 8 of 34
Date : Jan. 02, 2021

2.5 DESCRIPTION OF SUPPORT UNIT

The EUT was configured by the requirement of ANSI C63.10:2013. All interface ports were connected to the appropriate support units via specific cables. The support units and cables are listed below.

NO	DEVICE	BRAND	MODEL #	FCC ID/DOC	NOTE
1	Galaxy S8	SAMSUNG	SM-G90FD	CCAK174G0090 T1	64G
2	Micro SD card	Transcend	N/A	N/A	8G
3	Battery	SCB	SP7.2-12	N/A	12V

NOTE: For the actual test configuration, please refer to the photos of testing.

2.6 CHANNEL AND FREQUENCY TABLE

802.11g	
Channel	Frequency
CH01	2412 MHz



Spectrum Research & Testing Lab., Inc.

No.167,Ln. 780, Shan-Tong Rd.,Ling 8, Shan-Tong Li, Chung-Li Dist., Taoyuan City 320, Taiwan (R.O.C.)

TEST REPORT

Reference No. : A20092502
Report No. : FCCA20092502
FCC ID : 2AXURX5003
Page : 9 of 34
Date : Jan. 02, 2021

3. DESCRIPTION OF APPLIED STANDARDS

The EUT is a wireless product. According to the specifications provided by the applicant, it must comply with the requirements of the following standards:

47 CFR Part 15, Subpart C, 15.247

ANSI C63.10: 2013

All tests have been performed and recorded as the above standards.

3.1 DESCRIPTION OF APPLIED KDB

Related KDB used in the test:

FCC publication KDB 558074 D01 15.247 Meas Guidance v05r02 Measurement on Digital Transmission Systems (DTS) Operating under Section 15.247 Apr. 02, 2019

3.2 SUMMARY OF TEST RESULTS

The EUT has been tested according to the following specifications:

STANDARD SECTION	TEST TYPE AND LIMIT RESULTS	RESULT
15.203 15.247(c)(1)(i)	Antenna requirement	PASS
15.207	AC Power Line Conducted Emission	N/A
15.247(a)(2)	6 dB Bandwidth	PASS
15.247(b)	Maximum Peak Conducted Output Power	PASS
15.247(d)	Band Edge Measurement	PASS
15.247(d)	Transmitter Radiated Emissions Limit: Table 15.209	PASS
15.247(e)	Power Density: Limit: 8dBm/3kHz	PASS

**Spectrum Research & Testing Lab., Inc.**

No.167,Ln. 780, Shan-Tong Rd.,Ling 8, Shan-Tong Li, Chung-Li Dist., Taoyuan City 320, Taiwan (R.O.C.)

TEST REPORTReference No. : A20092502
Report No. : FCCA20092502
FCC ID : 2AXURX5003
Page : 10 of 34
Date : Jan. 02, 2021**4. TECHNICAL CHARACTERISTICS TEST****4.1 CONDUCTED EMISSION TEST****4.1.1 LIMIT**

Frequency (MHz)	Class A (dB μ V)		Class B (dB μ V)	
	Quasi-peak	Average	Quasi-peak	Average
0.15 - 0.5	79	66	66 - 56	56 - 46
0.50 - 5.0	73	60	56	46
5.0 - 30.0	73	60	60	50

NOTE:

1. The lower limit shall apply at the transition frequencies.
2. The limit decreases in line with the logarithm of the frequency in the range of 0.15 to 0.50 MHz.

4.1.2 TEST EQUIPMENT

The following test equipment was used for the test:

EQUIPMENT/ FACILITIES	SPECIFICATIONS	MANUFACTURER	MODEL#/ SERIAL#	DUE DATE OF CAL. & CAL. CENTER
EMI TEST RECEIVER	9 kHz ~ 30 MHz	ROHDE & SCHWARZ	ESHS30 / 826003/008	JAN. 13, 2021 ETC
LISN	50 μ H, 50 ohm	SOLAR	9252-50-R-24-BNC/951315	JAN. 20, 2021 ETC
LISN	50 μ H, 50 ohm	SCHWARZBECK	NSLK 8127/ 8127-808	MAR. 10, 2021 ETC
50 Ω BNC TYPE TERMINATOR	50 ohm	N/A	11593A/ L1TEQU005	FEB. 06, 2021 ETC
COAXIAL CABLE	5 m	HUBER+SUHNER	RG214/U / L1TCAB013(#5m)	MAY. 25, 2021 ETC
FILTER	2 LINE, 30 A	FIL.COIL	FC-943 / 771	NCR
GROUND PLANE	2 m (H) x 3 m (W)	SRT	N/A	NCR
GROUND PLANE	2.5 m (H) x 3 m (W)	SRT	N/A	NCR
PULSE LIMITER	9 kHz ~ 30 MHz Insertion Loss= 10dB \pm 0.3dB	ROHDE & SCHWARZ	ESH3Z2/ L1TTES009	MAR. 19, 2021 ETC
THERMO-HYGR O	15 – 40 $^{\circ}$ C, 0- 100% RH	TES	TES-1161/ 180704762	MAR. 05, 2021 ETC

NOTE:

The calibration interval of the above test equipment is one year and the calibrations are traceable to NML/ROC and NIST/USA.



4.1.3 TEST SETUP

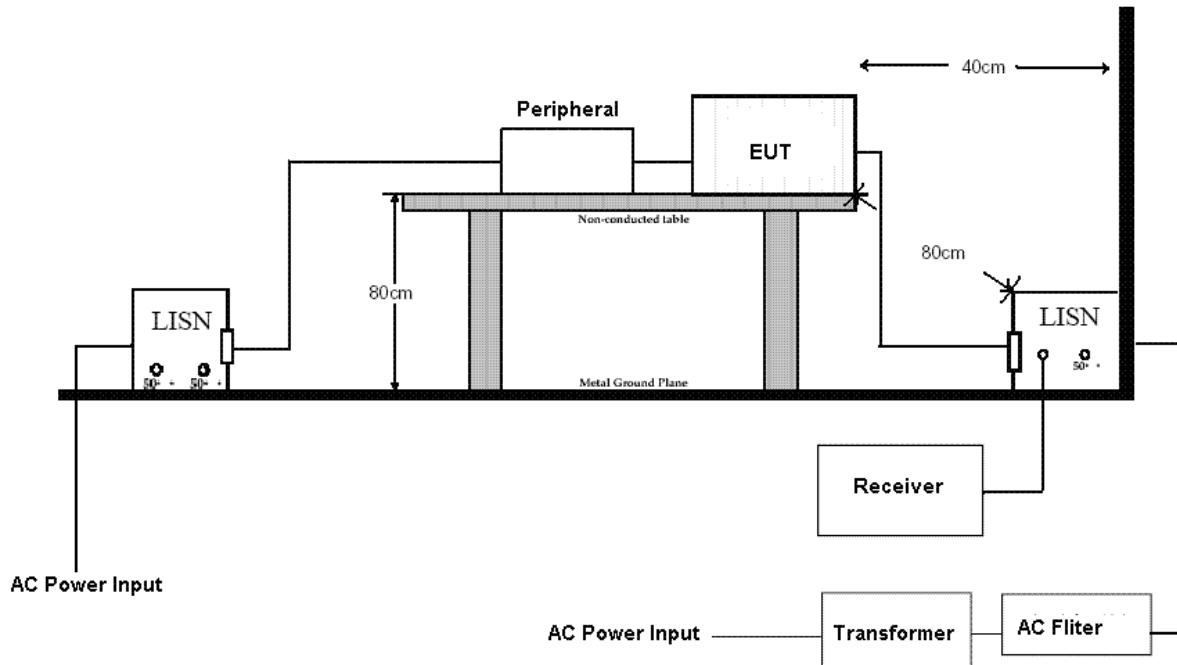

NOTE :

1. The EUT was put on a wooden table with 0.8m heights above ground plane, and 0.4m away from reference ground plane (> 2mx2m).
2. For the actual test configuration, please refer to the photos of testing.

4.1.4 TEST PROCEDURE

The EUT was tested according to the requirement of ANSI C63.10:2013 and CISPR22:2003. The frequency spectrum from 0.15 MHz to 30 MHz was investigated. The LISN used was 50 ohm/50 μ H as specified. All readings were quasi-peak and average values with 10 kHz resolution bandwidth of the test receiver. The EUT system was operated in all typical methods by users. Both lines of the power mains of EUT were measured and the cables connected to EUT and support units were moved to find the maximum emission levels for each frequency. First, find the margin or higher points at least 6 points by software, then use manual to find the maximum data. The procedure is referred on the test procedure of SRT LAB.

4.1.5 TEST RESULT

N/A

**Spectrum Research & Testing Lab., Inc.**

No.167,Ln. 780, Shan-Tong Rd.,Ling 8, Shan-Tong Li, Chung-Li Dist., Taoyuan City 320, Taiwan (R.O.C.)

TEST REPORTReference No. : A20092502
Report No. : FCCA20092502
FCC ID : 2AXURX5003
Page : 12 of 34
Date : Jan. 02, 2021**4.2 RADIATED EMISSION TEST****4.2.1 LIMIT**

FCC Part15, Subpart C Section 15.209 limit of radiated emission for frequency below 1000 MHz. The emissions from an intentional radiator shall not exceed the field strength levels specified in the following table:

FREQUENCY (MHz)	FIELD STRENGTH ($\mu\text{V}/\text{m}$)	DISTANCE (m)	FIELD STRENGTH ($\text{dB}\mu\text{V}/\text{m}$)
0.009 – 0.490	2400/F(kHz)	300	67.6-20log(kHz)
0.490 – 1.705	24000/F(kHz)	30	87.6-20log(kHz)
1.705 – 30	30	30	30
30 – 88	100	3	40.0
88 – 216	150	3	43.5
216 – 960	200	3	46.0
Above 960	500	3	54.0

NOTE:

1. 30 dBuV (in 30m) = 70 dBuV (in 3m).
2. In the emission tables above , the tighter limit applies at the band edges.
3. Distance refers to the distance between measuring instrument, antenna, and the closest point of any part of the device or system.

FCC Part 15, Section15.35(b) limit of radiated emission for frequency above 1000 MHz

FREQUENCY (MHz)	Class A (dBuV/m) (at 3m)		Class B (dBuV/m) (at 3m)	
	PEAK	AVERAGE	PEAK	AVERAGE
Above 1000	80.0	60.0	74.0	54.0

**Spectrum Research & Testing Lab., Inc.**

No.167,Ln. 780, Shan-Tong Rd.,Ling 8, Shan-Tong Li, Chung-Li Dist., Taoyuan City 320, Taiwan (R.O.C.)

TEST REPORTReference No. : A20092502
Report No. : FCCA20092502
FCC ID : 2AXURX5003
Page : 13 of 34
Date : Jan. 02, 2021**4.2.2 TEST EQUIPMENT**

Below 1 GHz The following test equipment was used during the radiated emission test:

EQUIPMENT/ FACILITIES	SPECIFICATIONS	MANUFACTURER	MODEL#/ SERIAL#	DUE DATE OF CAL. & CAL. CENTER	FINAL TEST BE USED
EMI TEST RECEIVER	9 kHz ~ 2.75 GHz	ROHDE & SCHWARZ	ESCS30 / 100376	JAN. 06, 2021 ETC	■
LOOP ANTENNA	9 kHz ~ 30 MHz	ROHDE & SCHWARZ	HFH2-Z2/ 860605/002	MAY 21, 2021 ETC	□
BICONICAL ANTENNA	30 MHz ~ 200 MHz	EMCO	3108/ 2334	NOV. 14, 2021 ETC	■
LOG PERIODIC ANTENNA	200 MHz ~ 1 GHz	EMCO	3146/ 9002-2686	MAR. 01, 2021 ETC	■
OPEN AREA TEST SITE	3 – 10 M MEASUREMENT	SRT	A02 / SRT002	MAR. 06, 2021 SRT	■
COAXIAL CABLE	30 M	TIMES	LMR-400 / #30M(L1TCAB014)	JUN. 08, 2021 ETC	■
COAXIAL CABLE	9k - 1GHz	TIMES	LMR-400(#2m) / L1TCAB012	JAN. 05, 2021 ETC	■
FILTER	2 LINE, 30 A	FIL.COIL	FC-943/869	NCR	■
PRE-AMPLIFIER	0.1 MHz ~ 1.3 GHz	HP	8447D / 2944A06746	MAR. 08, 2021 ETC	■
THERMO-HYGRO	15 – 40°C, 0- 100% RH	TOP	20-A / 6644	SEP. 07, 2021 ETC	■

Above 1 GHz The following test equipment was used during the radiated emission test:

EQUIPMENT/ FACILITIES	SPECIFICATIONS	MANUFACTURER	MODEL#/ SERIAL#	DUE DATE OF CAL. & CAL. CENTER	FINAL TEST BE USED
SPECTRUM ANALYZER	9 kHz ~ 40GHz	ROHDE & SCHWARZ	FSP40 / 100093	JAN.06, 2021 ETC	■
PRE-AMPLIFIER	1 GHz ~ 26.5 GHz	AGILENT	8449B/ 3008A01995	JAN.05, 2021 ETC	■
HORN ANTENNA	1 GHz ~ 18 GHz	EMCO	3115/9602-4681	NOV.13, 2021 ETC	■
HORN ANTENNA	18 ~ 40 GHZ	ETS-LINDGREN	3116/00032255	JAN. 14, 2021 ETC	■
ANECHOIC CHAMBER	3 M MEASUREMENT	SRT	A01/SRT001	DEC. 13, 2021 SRT	■
RF CABLE	UP TO 18 GHz 1.5 m	JYEBAO	A30A30-L 142 / EQF-0035(001)	FEB. 24, 2021 ETC	■
RF CABLE	UP TO 26.5 GHz 3.5 m	EMCI	EMC104-SM-SM-3 500 / 150601	FEB. 18, 2021 ETC	■
K-TYPE CABLE	UP TO 40 GHz 3 m	HUBER+SUHNER	SF102-46/2*11SK2 52 /MY2611/2	MAR. 15, 2021 ETC	■
K-TYPE CABLE	UP TO 40 GHz, 1 m	HUBER+SUHNER	SF102/2*11SK252 /MY3331/2	SEP. 16, 2021 ETC	■
FILTER	2 LINE, 30 A	FIL.COIL	FC-943/869	NCR	■
THERMO-HYGRO	15 – 40 °C, 0- 100% RH	TOP	20-A / 6644	SEP. 07, 2021 ETC	■



4.2.3 TEST SET-UP

30 MHz ~ 1 GHz

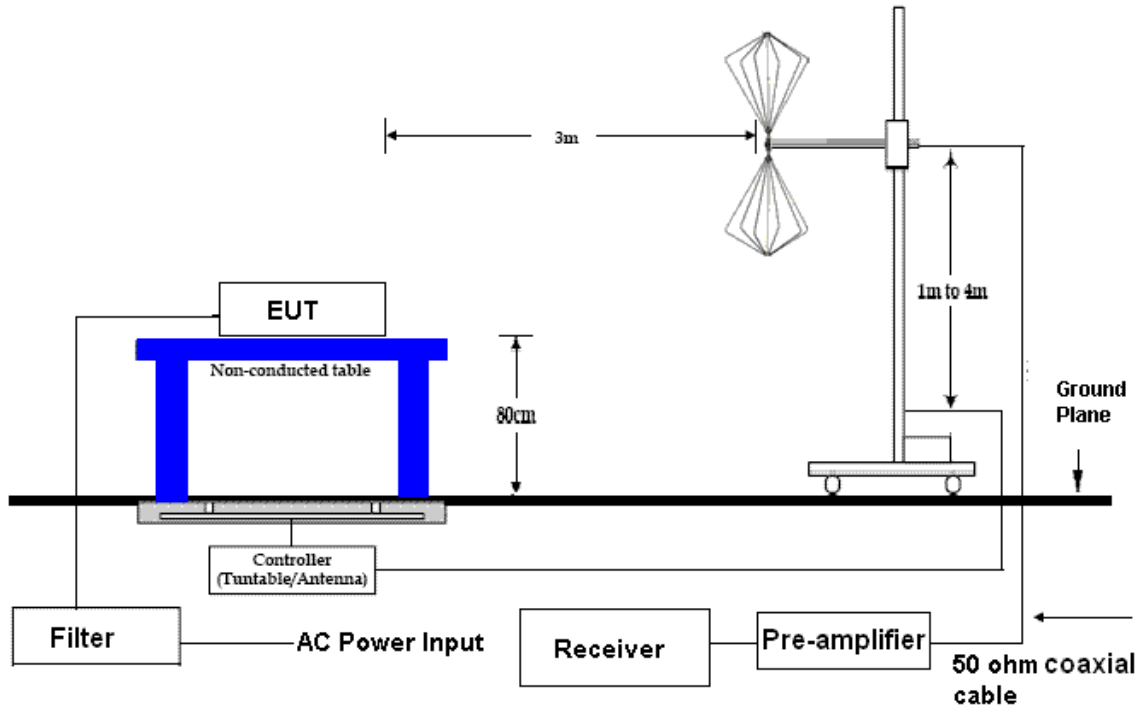

Above 1 GHz

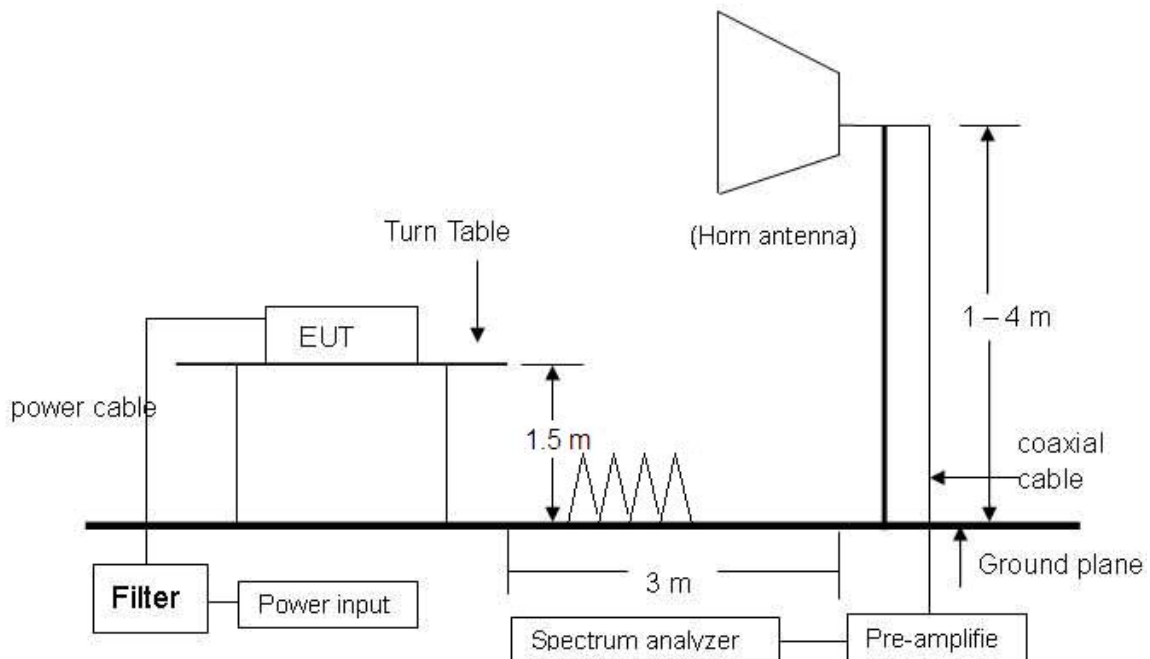

NOTE: The EUT system was put on a wooden table with 1.5m heights above a ground plane. For the actual test configuration, please refer to the photos of testing.



Spectrum Research & Testing Lab., Inc.

No.167, Ln. 780, Shan-Tong Rd., Ling 8, Shan-Tong Li, Chung-Li Dist., Taoyuan City 320, Taiwan (R.O.C.)

TEST REPORT

Reference No. : A20092502
Report No. : FCCA20092502
FCC ID : 2AXURX5003
Page : 15 of 34
Date : Jan. 02, 2021

4.2.4 TEST PROCEDURE

The EUT was tested according to the requirement of ANSI C63.10:2013 and CISPR 22:2003. When the frequency spectrum measured started from 30 MHz to 1 GHz, then used antenna is a BICONICAL ANTENNA & LOG PERIODIC ANTENNA. The measurements were made at an open area test site with 3 meter measurement distance under 1 GHz and with 3 meter distance above 1GHz. The frequency spectrum measured started from 30 MHz to 1 GHz, all readings were quasi-peak values with 120 kHz resolution bandwidth of the test receiver. Above 1 GHz, the measurements were made at an open area test site with 3 meter measurement distance and all readings were peak or average values with 1 MHz resolution bandwidth of the test receiver. The EUT system was operated in all typical methods by users. The cables connected to EUT and support units were moved to find the maximum emission levels for each frequency. First, find the margin or higher points at least 6 points by software, then find the maximum data manually. The procedure is referred on the test procedure of SRT LAB.

**Spectrum Research & Testing Lab., Inc.**

No.167, Ln. 780, Shan-Tong Rd., Ling 8, Shan-Tong Li, Chung-Li Dist., Taoyuan City 320, Taiwan (R.O.C.)

TEST REPORTReference No. : A20092502
Report No. : FCCA20092502
FCC ID : 2AXURX5003
Page : 16 of 34
Date : Jan. 02, 2021**4.2.5 TEST RESULT**

Temperature:	24 °C	Humidity:	79 %RH
Frequency Range:	30 M – 1 GHz	Tested Mode:	802.11g_CH01
Detector Type:	Quasi-peak	IF Bandwidth:	120 kHz
Tested By:	David Hung	Tested Date:	Oct. 13, 2020

Antenna Polarization : Horizontal

Frequency (MHz)	Cable Loss (dB)	Antenna Factor (dB/m)	Pre-Amp (dB)	Reading Data (dBμV)	Emission Level (dBμV/m)	Limit (dBμV/m)	Margin (dB)	AZ(°)	EL(m)
123.75	2.51	11.80	28.01	42.12	28.41	44	-15.09	113	3.63
527.90	5.81	18.74	28.54	39.43	35.44	46	-10.56	185	2.42
623.63	6.45	19.90	28.54	36.66	34.46	46	-11.54	37	2.13
672.48	6.77	20.84	28.46	31.31	30.46	46	-15.54	163	1.98
721.29	7.08	21.40	28.37	33.13	33.24	46	-12.76	204	1.84
816.70	7.71	22.52	28.12	30.29	32.40	46	-13.60	312	1.55

Antenna Polarization : Vertical

Frequency (MHz)	Cable Loss (dB)	Antenna Factor (dB/m)	Pre-Amp (dB)	Reading Data (dBμV)	Emission Level (dBμV/m)	Limit (dBμV/m)	Margin (dB)	AZ(°)	EL(m)
77.26	2.04	8.30	28.21	39.70	21.83	40	-18.17	43	3.77
336.30	4.37	15.20	27.59	36.32	28.30	46	-17.70	165	2.99
442.48	5.20	17.02	28.24	32.53	26.51	46	-19.49	91	2.67
527.45	5.81	18.74	28.54	37.58	33.60	46	-12.40	194	2.42
623.87	6.45	19.90	28.54	29.54	27.34	46	-18.66	79	2.13
720.81	7.08	21.40	28.37	30.02	30.12	46	-15.88	332	1.84

NOTE :

1. Measurement uncertainty is 4.20 dB.
2. "": Measurement does not apply for this frequency.
3. Emission Level = Reading Value + Ant. Factor + Cable Loss – Pre-Amplifier.
4. The field strength of other emission frequencies were very low against the limit.

**Spectrum Research & Testing Lab., Inc.**

No.167,Ln. 780, Shan-Tong Rd.,Ling 8, Shan-Tong Li, Chung-Li Dist., Taoyuan City 320, Taiwan (R.O.C.)

TEST REPORTReference No. : A20092502
Report No. : FCCA20092502
FCC ID : 2AXURX5003
Page : 17 of 34
Date : Jan. 02, 2021

Temperature:	24 °C	Humidity:	79 %RH
Frequency Range:	1 GHz – 25 GHz	Tested Mode:	802.11g_CH01
Detector Type:	PK. And AV.	IF Bandwidth:	1 MHz
Tested By:	David Hung	Tested Date:	Oct. 13, 2020

Antenna Polarization : Horizontal

Frequency (MHz)	Correct Factor (dB)	Ant. Factor (dB/m)	Reading Data (dB μ V)		Emission Level (dB μ V/m)		Limit (dB μ V/m)		Margin (dB)		AZ (°)	EL (m)
			PK.	AV.	PK.	AV.	PK.	AV.	PK.	AV.		
1356.25	-33.10	26.81	47.69	38.05	41.40	31.76	74	54	-32.60	-22.24	68	1.97
2175.38	-31.68	27.55	44.84	34.67	40.71	30.54	74	54	-33.29	-23.46	156	1.76
3033.35	-31.09	30.43	42.87	32.93	42.21	32.27	74	54	-31.79	-21.73	135	1.59
4134.42	-29.84	32.20	43.28	32.91	45.64	35.27	74	54	-28.36	-18.73	175	1.37
4440.70	-29.50	32.20	43.72	33.66	46.42	36.36	74	54	-27.58	-17.64	302	1.31
5514.93	-28.70	33.87	42.50	31.99	47.67	37.16	74	54	-26.33	-16.84	213	1.10

Antenna Polarization : Vertical

Frequency (MHz)	Correct Factor (dB)	Ant. Factor (dB/m)	Reading Data (dB μ V)		Emission Level (dB μ V/m)		Limit (dB μ V/m)		Margin (dB)		AZ (°)	EL (m)
			PK.	AV.	PK.	AV.	PK.	AV.	PK.	AV.		
1344.45	-33.14	26.76	44.41	33.43	38.04	27.06	74	54	-35.96	-26.94	141	1.07
2269.24	-31.61	27.88	43.97	33.94	40.24	30.21	74	54	-33.76	-23.79	171	1.25
2744.74	-31.29	28.90	45.13	35.46	42.74	33.07	74	54	-31.26	-20.93	294	1.35
3018.39	-31.11	30.37	43.64	34.49	42.90	33.75	74	54	-31.10	-20.25	178	1.40
4285.74	-29.67	32.07	43.13	32.65	45.53	35.05	74	54	-28.47	-18.95	79	1.66
5696.27	-28.67	33.79	42.41	32.60	47.53	37.72	74	54	-26.47	-16.28	150	1.92

NOTE:

1. Measurement uncertainty is 4.04 dB.
2. Emission Level = Reading Value + Ant. Factor + Correct Factor (incl.:Cable Loss and Pre-Amplifier Gain)
3. The field strength of other emission frequencies were very low against the limit.
4. (F):The field strength of fundamental frequency.

**Spectrum Research & Testing Lab., Inc.**

No.167,Ln. 780, Shan-Tong Rd.,Ling 8, Shan-Tong Li, Chung-Li Dist., Taoyuan City 320, Taiwan (R.O.C.)

TEST REPORTReference No. : A20092502
Report No. : FCCA20092502
FCC ID : 2AXURX5003
Page : 18 of 34
Date : Jan. 02, 2021

Temperature:	24 °C	Humidity:	79 %RH
Frequency Range:	1 GHz – 25 GHz	Tested Mode:	802.11g_CH01 (Fundamental and Harmonics)
Detector Type:	PK. and AV.	IF Bandwidth:	1 MHz
Tested By:	David Hung	Tested Date:	Oct. 13, 2020

Antenna Polarization : Horizontal

Frequency (MHz)	Correct Factor (dB)	Ant. Factor (dB/m)	Reading Data (dB μ V)		Emission Level (dB μ V/m)		Limit (dB μ V/m)		Margin (dB)		AZ (°)	EL (m)
			PK.	AV.	PK.	AV.	PK.	AV.	PK.	AV.		
2412.00 (F)	-31.50	28.05	84.37	72.56	80.92	69.11	-	-	-	-	251	1.65
4824.00	-28.99	32.90	39.32	28.13	43.23	32.04	74	54	-30.77	-21.96	178	1.55
7236.00	-28.01	36.27	41.88	30.68	50.14	38.94	74	54	-23.86	-15.06	102	1.53
9648.00	-27.63	37.60	41.03	30.44	51.00	40.42	74	54	-23.00	-13.58	66	1.62
12060.00	-25.98	39.08	40.15	29.32	53.25	42.42	74	54	-20.75	-11.58	207	1.57
14472.00	-23.63	42.37	42.49	31.22	61.22	49.96	74	54	-12.78	-4.04	299	1.60

Antenna Polarization : Vertical

Frequency (MHz)	Correct Factor (dB)	Ant. Factor (dB/m)	Reading Data (dB μ V)		Emission Level (dB μ V/m)		Limit (dB μ V/m)		Margin (dB)		AZ (°)	EL (m)
			PK.	AV.	PK.	AV.	PK.	AV.	PK.	AV.		
2412.00 (F)	-31.50	28.05	84.51	72.61	81.06	69.16	-	-	-	-	342	1.58
4824.00	-28.99	32.90	40.70	30.11	44.61	34.02	74	54	-29.39	-19.98	239	1.65
7236.00	-28.01	36.27	41.97	30.98	50.23	39.24	74	54	-23.77	-14.76	128	1.59
9648.00	-27.63	37.60	39.76	30.37	49.73	40.35	74	54	-24.27	-13.65	224	1.55
12060.00	-25.98	39.08	38.48	29.15	51.58	42.25	74	54	-22.42	-11.75	158	1.61
14472.00	-23.63	42.37	41.27	31.28	60.01	50.02	74	54	-13.99	-3.98	270	1.63

NOTE:

1. Measurement uncertainty is 4.04 dB.
2. Emission Level = Reading Value + Ant. Factor + Correct Factor (incl.:Cable Loss and Pre-Amplifier Gain)
3. The field strength of other emission frequencies were very low against the limit.
4. (F):The field strength of fundamental frequency.



Spectrum Research & Testing Lab., Inc.

No.167, Ln. 780, Shan-Tong Rd., Ling 8, Shan-Tong Li, Chung-Li Dist., Taoyuan City 320, Taiwan (R.O.C.)

TEST REPORT

Reference No. : A20092502
Report No. : FCCA20092502
FCC ID : 2AXURX5003
Page : 19 of 34
Date : Jan. 02, 2021

4.3 BANDWIDTH TEST

4.3.1 LIMIT

FCC Part15, Subpart C Section 15.247 (a)(2). The minimum 6dB bandwidth shall be at least 500 kHz.

4.3.2 TEST EQUIPMENT

The following test equipment was used during the test :

EQUIPMENT/ FACILITIES	SPECIFICATIONS	MANUFACTURER	MODEL#/ SERIAL#	DUE DATE OF CAL. & CAL. CENTER
EMI TEST RECEIVER (INCLUDE SPECTRUM ANALYZER)	9 KHz ~ 6 GHz	ROHDE & SCHWARZ	ESL /100176	JUL. 30, 2021 ETC

NOTE: The calibration interval of the above test equipment is one year and the calibrations are traceable to NML/ROC and NIST/USA.

4.3.3 TEST SET-UP

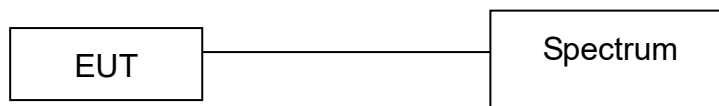

The EUT was connected to a spectrum through a 50Ω RF cable.

4.3.4 TEST PROCEDURE

The EUT was operated in continuous transmission mode at specific channel.

Print out the test result by printing function on the spectrum.

4.3.5 EUT OPERATING CONDITION

1. Set the EUT under continuous transmission condition.
2. The EUT was set to the highest available power level.



Spectrum Research & Testing Lab., Inc.

No.167,Ln. 780, Shan-Tong Rd.,Ling 8, Shan-Tong Li, Chung-Li Dist., Taoyuan City 320, Taiwan (R.O.C.)

TEST REPORT

Reference No. : A20092502
Report No. : FCCA20092502
FCC ID : 2AXURX5003
Page : 20 of 34
Date : Jan. 02, 2021

4.3.6 TEST RESULT

6 dB Bandwidth :

Temperature:	24 °C	Humidity:	79 %RH
Spectrum Detector:	Peak	Test Mode:	802.11g
RBW:	100 kHz	VBW:	300 kHz
Tested By:	David Hung	Tested Date:	Oct. 13, 2020

Channel Number	Channel Frequency (MHz)	6dB Bandwidth (MHz)	Minimum Limit (MHz)
CH01	2412	5.99	0.5

1.90 MHz + 4.09 MHz = 5.99 MHz

G_CH01 :

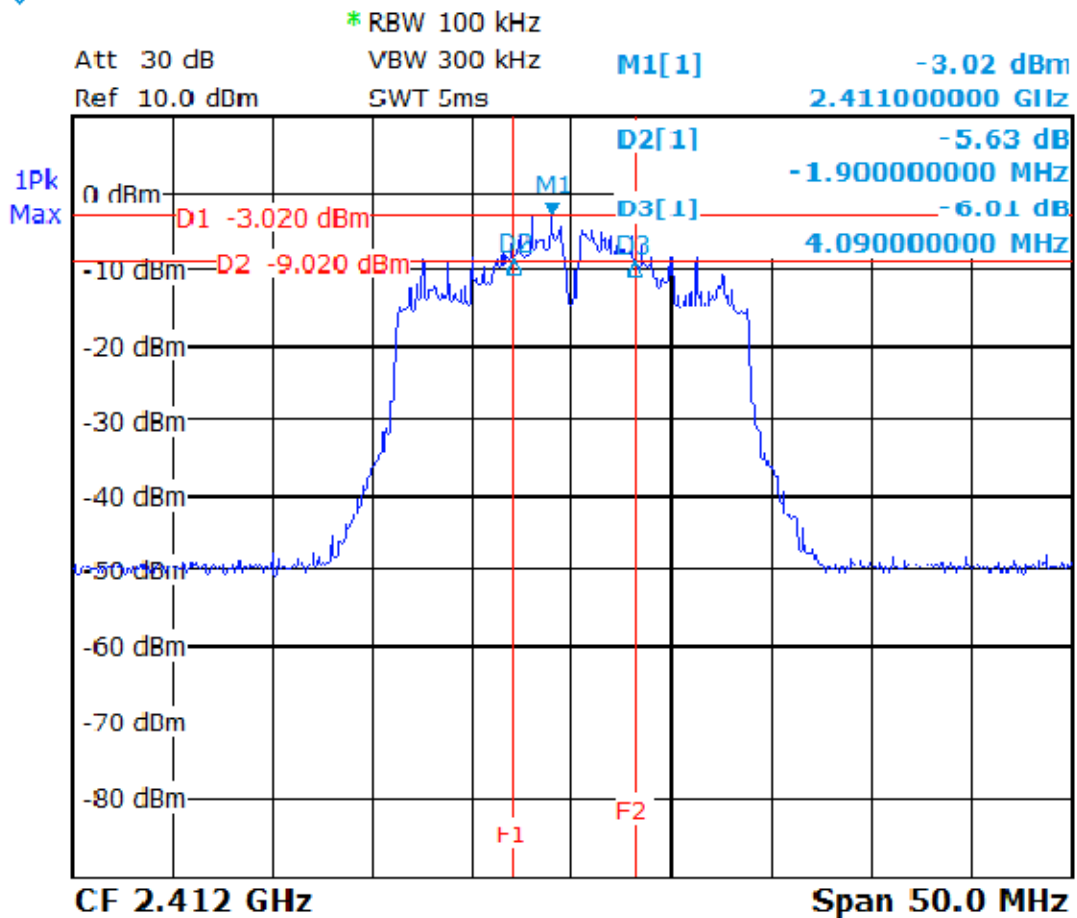



Spectrum Research & Testing Lab., Inc.

No.167, Ln. 780, Shan-Tong Rd., Ling 8, Shan-Tong Li, Chung-Li Dist., Taoyuan City 320, Taiwan (R.O.C.)

TEST REPORT

Reference No. : A20092502
Report No. : FCCA20092502
FCC ID : 2AXURX5003
Page : 21 of 34
Date : Jan. 02, 2021

99% Bandwidth :

Temperature:	24 °C	Humidity:	79 %RH
Spectrum Detector:	Peak	Test Mode:	802.11g
RBW:	100 kHz	VBW:	300 kHz
Tested By:	David Hung	Tested Date:	Oct. 13, 2020

Channel Number	Channel Frequency (MHz)	99% Bandwidth (MHz)
CH01	2412	17.37

G_CH01 :

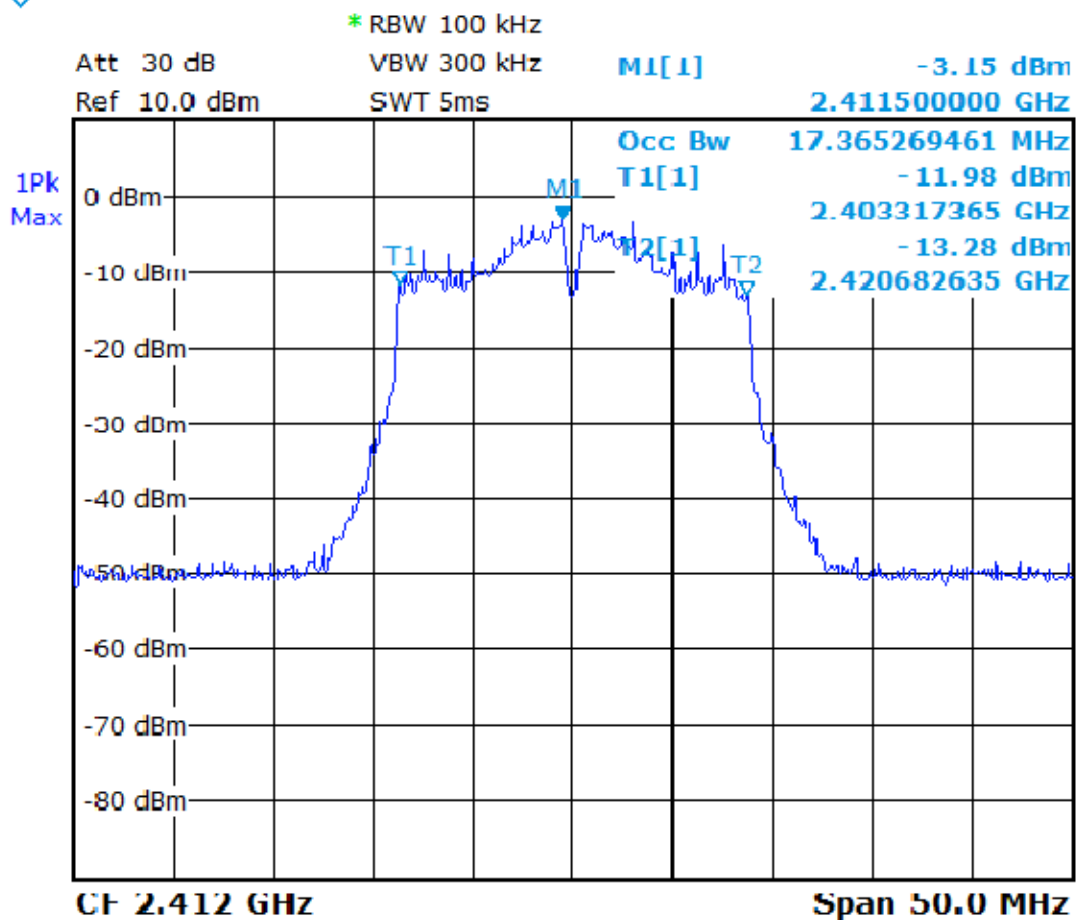



Spectrum Research & Testing Lab., Inc.

No.167, Ln. 780, Shan-Tong Rd., Ling 8, Shan-Tong Li, Chung-Li Dist., Taoyuan City 320, Taiwan (R.O.C.)

TEST REPORT

Reference No. : A20092502
Report No. : FCCA20092502
FCC ID : 2AXURX5003
Page : 22 of 34
Date : Jan. 02, 2021

4.4 PEAK CONDUCTED OUTPUT POWER TEST

4.4.1 LIMIT

FCC Part15, Subpart C Section 15.247(b).

The maximum peak conducted output power of the intentional radiator shall not exceed the following:

For systems using digital modulation in the 902-928 MHz, 2400-2483.5 MHz, and 5725-5850 MHz bands: 1 Watt.

4.4.2 TEST EQUIPMENT

The following test equipment was used during the test :

EQUIPMENT/ FACILITIES	SPECIFICATIONS	MANUFACTURER	MODEL#/ SERIAL#	DUE DATE OF CAL. & CAL. CENTER
EMI TEST RECEIVER (INCLUDE SPECTRUM ANALYZER)	9 KHz ~ 6 GHz	ROHDE & SCHWARZ	ESL /100176	JUL. 30, 2021 ETC

NOTE: The calibration interval of the above test equipment is one year and the calibrations are traceable to NML/ROC and NIST/USA.

4.4.3 TEST SET-UP

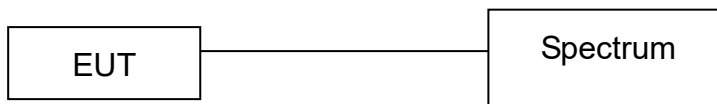

The EUT was connected to a spectrum through a 50Ω RF cable.

4.4.4 TEST PROCEDURE

The EUT was operating in continuous transmission mode or could control its channel.

Print out the test result by printing function on the spectrum.

4.4.5 EUT OPERATING CONDITION

1. Set the EUT under continuous transmission condition.
2. The EUT was set to the highest available power level.



Spectrum Research & Testing Lab., Inc.

No.167,Ln. 780, Shan-Tong Rd.,Ling 8, Shan-Tong Li, Chung-Li Dist., Taoyuan City 320, Taiwan (R.O.C.)

TEST REPORT

Reference No. : A20092502
Report No. : FCCA20092502
FCC ID : 2AXURX5003
Page : 23 of 34
Date : Jan. 02, 2021

4.4.6 TEST RESULT

Temperature:	24 °C	Humidity:	79 %RH
Detector:	RMS	Tested mode:	802.11g
RBW:	300 kHz	VBW:	1 MHz
Tested By:	David Hung	Tested Date:	Oct. 13, 2020

Channel Number	Channel Frequency (MHz)	99% Bandwidth (MHz)	Peak Conducted Output Power		Limit (dB)
			(dBm)	(mW)	
CH01	2412	17.37	-9.12	0.12	30

G_CH01 :

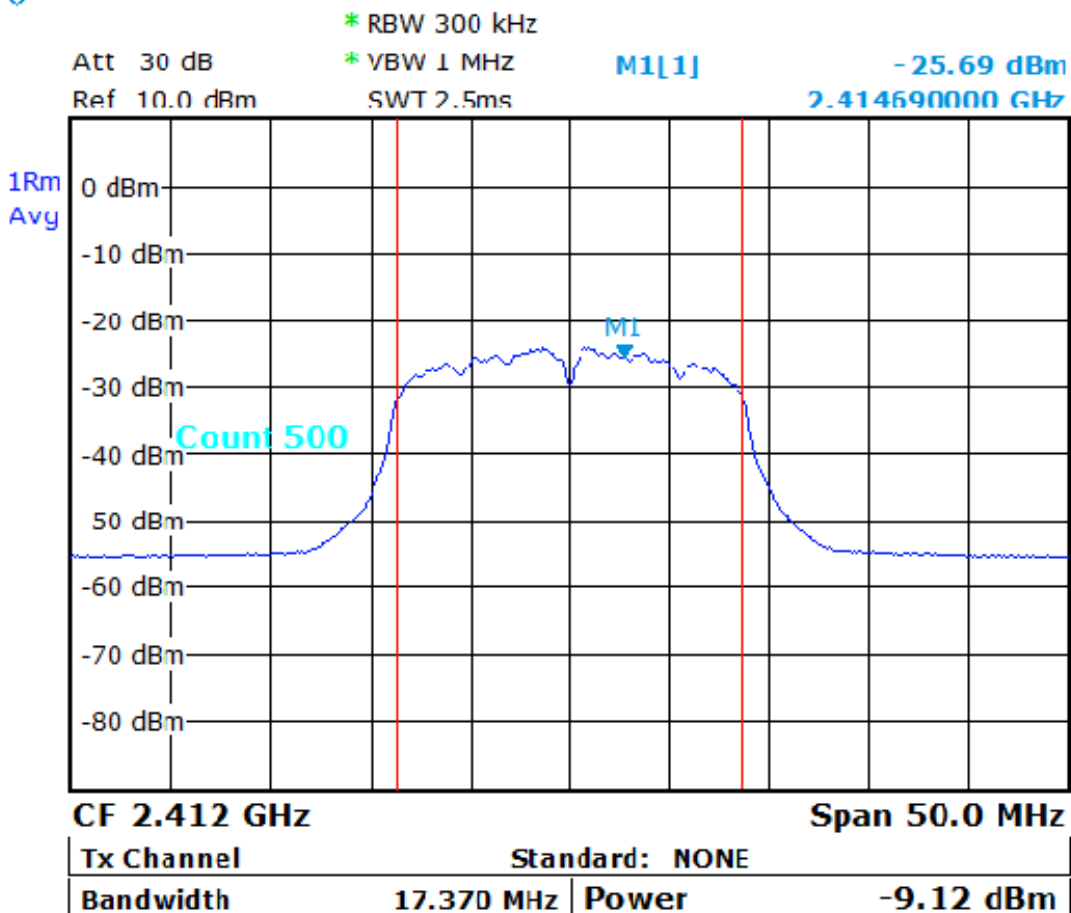



Spectrum Research & Testing Lab., Inc.

No.167, Ln. 780, Shan-Tong Rd., Ling 8, Shan-Tong Li, Chung-Li Dist., Taoyuan City 320, Taiwan (R.O.C.)

TEST REPORT

Reference No. : A20092502
Report No. : FCCA20092502
FCC ID : 2AXURX5003
Page : 24 of 34
Date : Jan. 02, 2021

4.5 BAND EDGE TEST

4.5.1 LIMIT

FCC Part15, Subpart C Section 15.247(d).

In any 100 kHz bandwidth outside the frequency band in which the spread spectrum intentional radiator is operating, the radio frequency power that is produced by the intentional radiator shall be at least 20 dB below that in the 100 kHz bandwidth within the band that contains the highest level of the desired power, based on either an RF conducted or a radiated measurement. Attenuation below the general limits specified in Section 15.209(a) is not required. In addition, radiated emissions which fall in the restricted bands, as defined in Section 15.205(a), must also comply with the radiated emission limits specified in Section 15.209(a) (see Section 15.205(c)).

OPERATING FREQUENCY RANGE (MHZ)	SPURIOUS EMISSION FREQUENCY (MHZ)	LIMIT	
		Peak power ration to emission(dBc)	Emission level(dBuV/m)
2400-2483.5	< 2400	> 20	N/A
	> 2483.5-2500	N/A	54

**Spectrum Research & Testing Lab., Inc.**

No.167, Ln. 780, Shan-Tong Rd., Ling 8, Shan-Tong Li, Chung-Li Dist., Taoyuan City 320, Taiwan (R.O.C.)

TEST REPORTReference No. : A20092502
Report No. : FCCA20092502
FCC ID : 2AXURX5003
Page : 25 of 34
Date : Jan. 02, 2021**4.5.2 TEST EQUIPMENT**

The following test equipment was used during the test:

EQUIPMENT/ FACILITIES	SPECIFICATIONS	MANUFACTURER	MODEL#/ SERIAL#	DUE DATE OF CAL. & CAL. CENTER	FINAL TEST BE USED
SPECTRUM ANALYZER	9 kHz ~ 40GHz	ROHDE & SCHWARZ	FSP40 / 100093	JAN.06, 2021 ETC	■
PRE-AMPLIFIER	1 GHz ~ 26.5 GHz	AGILENT	8449B/ 3008A01995	JAN.05, 2021 ETC	■
HORN ANTENNA	1 GHz ~ 18 GHz	EMCO	3115/9602-4681	NOV.13, 2021 ETC	■
HORN ANTENNA	18 ~ 40 GHZ	ETS-LINDGREN	3116/00032255	JAN. 14, 2021 ETC	■
ANECHOIC CHAMBER	3 M MEASUREMENT	SRT	A01/SRT001	DEC. 13, 2021 SRT	■
RF CABLE	UP TO 18 GHz 1.5 m	JYEBAO	A30A30-L 142 / EQF-0035(001)	FEB. 24, 2021 ETC	■
RF CABLE	UP TO 26.5 GHz 3.5 m	EMCI	EMC104-SM-SM-3 500 / 150601	FEB. 18, 2021 ETC	■
K-TYPE CABLE	UP TO 40 GHz 3 m	HUBER+SUHNER	SF102-46/2*11SK2 52 /MY2611/2	MAR. 15, 2021 ETC	■
K-TYPE CABLE	UP TO 40 GHz, 1 m	HUBER+SUHNER	SF102/2*11SK252 /MY3331/2	SEP. 16, 2021 ETC	■
FILTER	2 LINE, 30 A	FIL.COIL	FC-943/869	NCR	■
THERMO-HYGRO	15 – 40 °C, 0- 100% RH	TOP	20-A / 6644	SEP. 07, 2021 ETC	■

NOTE: The calibration interval of the above test equipment is one year and the calibrations are traceable to NML/ROC and NIST/USA



4.5.3 TEST SETUP

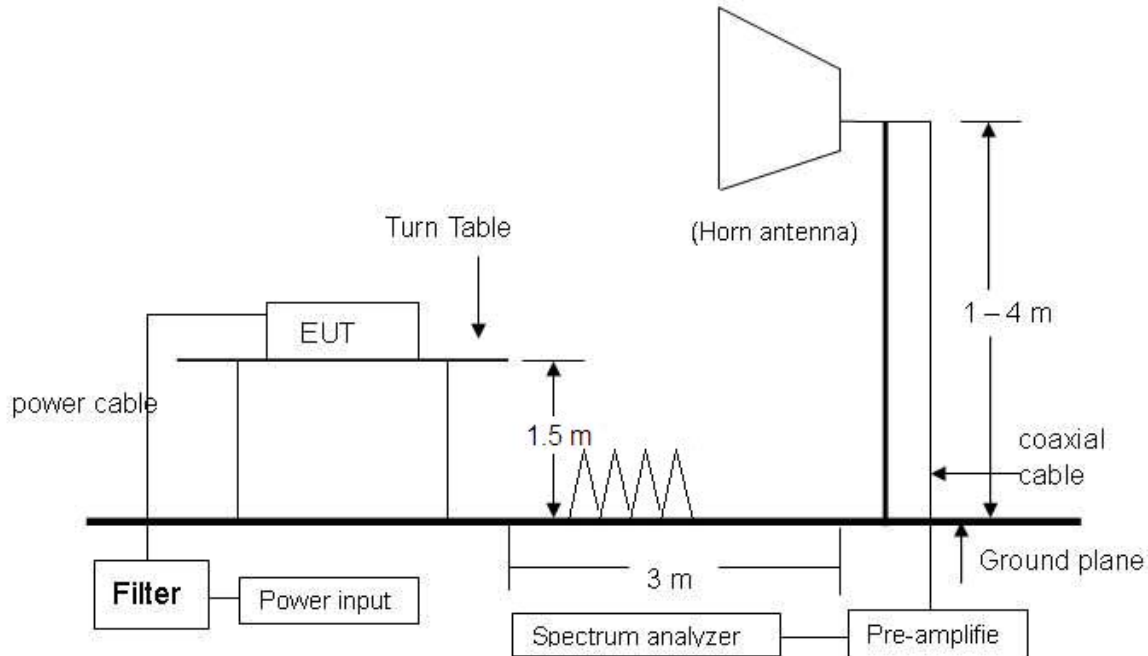

NOTE: The EUT system was put on a wooden table with 1.5m heights above a ground plane. For the actual test configuration, please refer to the photos of testing.

4.5.4 TEST PROCEDURE

The EUT was tested according to the requirement of ANSI C63.10:2013 and CISPR 22:2003. When the frequency spectrum measured started from 30 MHz to 1 GHz, then used antenna is a BICONICAL ANTENNA & LOG PERIODIC ANTENNA. The measurements were made at an open area test site with 3 meter measurement distance under 1 GHz and with 3 meter distance above 1GHz. The frequency spectrum measured started from 30 MHz to 1 GHz, all readings were quasi-peak values with 120 kHz resolution bandwidth of the test receiver. Above 1 GHz, the measurements were made at an open area test site with 3 meter measurement distance and all readings were peak or average values with 1 MHz resolution bandwidth of the test receiver. The EUT system was operated in all typical methods by users. The cables connected to EUT and support units were moved to find the maximum emission levels for each frequency. First, find the margin or higher points at least 6 points by software, then find the maximum data manually. The procedure is referred on the test procedure of SRT LAB.



**Spectrum Research &
Testing Lab., Inc.**

No.167, Ln. 780, Shan-Tong
Rd., Ling 8, Shan-Tong Li,
Chung-Li Dist., Taoyuan City
320, Taiwan (R.O.C.)

TEST REPORT

Reference No. : A20092502
Report No. : FCCA20092502
FCC ID : 2AXURX5003
Page : 27 of 34
Date : Jan. 02, 2021

4.5.5 EUT OPERATING CONDITION

1. Set the EUT under continuous transmission condition.
2. The EUT was set to the highest available power level.

**Spectrum Research & Testing Lab., Inc.**

No.167, Ln. 780, Shan-Tong Rd., Ling 8, Shan-Tong Li, Chung-Li Dist., Taoyuan City 320, Taiwan (R.O.C.)

TEST REPORTReference No. : A20092502
Report No. : FCCA20092502
FCC ID : 2AXURX5003
Page : 28 of 34
Date : Jan. 02, 2021**4.5.6 TEST RESULT**

Below 2400 MHz (G_CH01)

Temperature:	24 °C	Humidity:	79 %RH
Frequency Range:	2.30 GHz – 2.44 GHz	Tested Mode:	802.11g
Detector Type:	PK. and AV.	IF Bandwidth:	1 MHz
Tested By:	David Hung	Tested Date:	Oct. 13, 2020

Frequency (MHz)	Correct Factor (dB)	Ant. Fac. (dB/m)	Ant. Pol. (H/V)	Reading (dBμV)		Emission (dBμV/m)		Limit Line (dBμV/m)		Over Limit (dB)	
				PK.	AV.	PK.	AV.	PK.	AV.	PK.	AV.
2398.84	-31.51	28.00	H	53.35	43.01	49.84	39.50	74	54	-24.16	-14.50
2396.18	-31.51	28.00	V	50.07	41.06	46.56	37.55	74	54	-27.44	-16.45
2400.00	-31.51	28.00	H	48.36	39.16	44.85	35.66	74	54	-29.15	-18.34
2400.00	-31.51	28.00	V	45.10	35.40	41.59	31.89	74	54	-32.41	-22.11

Above 2483.5 MHz (G_CH01)

Temperature:	24 °C	Humidity:	79 %RH
Frequency Range:	2.4 GHz – 2.6 GHz	Tested Mode:	802.11g
Detector Type:	PK. and AV.	IF Bandwidth:	1 MHz
Tested By:	David Hung	Tested Date:	Oct. 13, 2020

Frequency (MHz)	Correct Factor (dB)	Ant. Fac. (dB/m)	Ant. Pol. (H/V)	Reading (dBμV)		Emission (dBμV/m)		Limit Line (dBμV/m)		Over Limit (dB)	
				PK.	AV.	PK.	AV.	PK.	AV.	PK.	AV.
2483.50	-31.44	28.40	H	33.58	23.64	30.54	20.60	74	54	-43.46	-33.40
2483.50	-31.44	28.40	V	34.28	23.87	31.24	20.82	74	54	-42.76	-33.18
2526.40	-31.41	28.55	H	34.79	24.97	31.93	22.11	74	54	-42.07	-31.89
2532.60	-31.41	28.56	V	36.32	25.53	33.47	22.69	74	54	-40.53	-31.31



Spectrum Research & Testing Lab., Inc.

No.167, Ln. 780, Shan-Tong Rd., Ling 8, Shan-Tong Li, Chung-Li Dist., Taoyuan City 320, Taiwan (R.O.C.)

TEST REPORT

Reference No. : A20092502
Report No. : FCCA20092502
FCC ID : 2AXURX5003
Page : 29 of 34
Date : Jan. 02, 2021

Below 2400 MHz (G_CH01)

Antenna Polarization : Horizontal



Antenna Polarization : Vertical

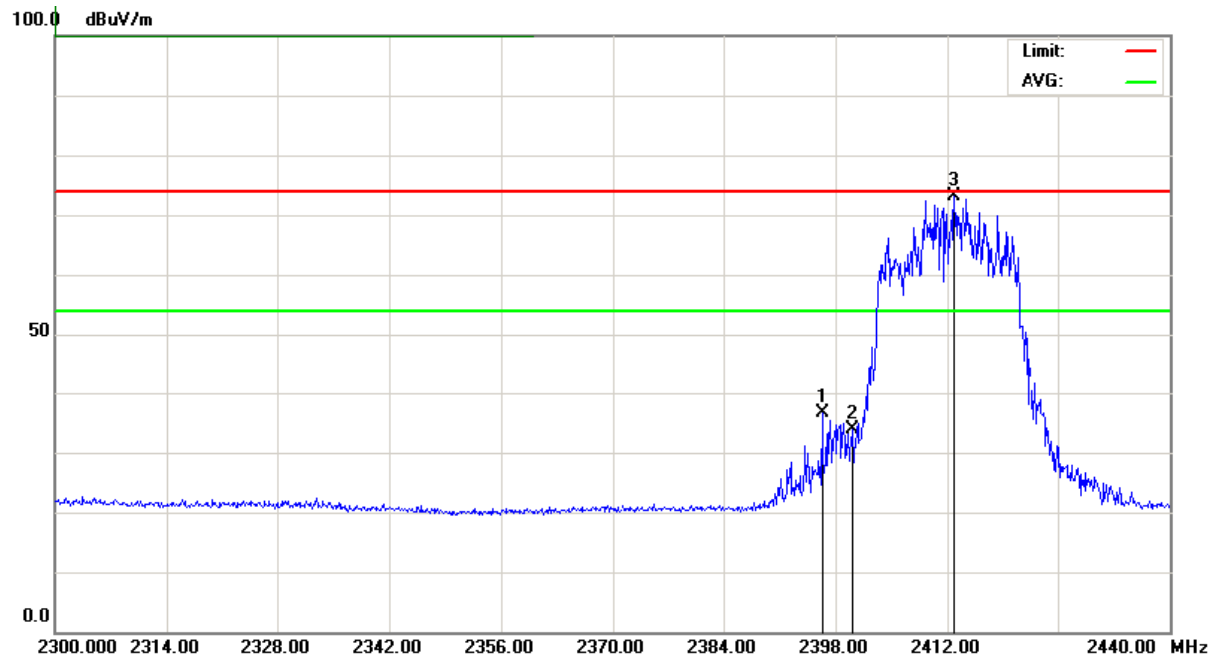



Spectrum Research & Testing Lab., Inc.

No.167, Ln. 780, Shan-Tong Rd., Ling 8, Shan-Tong Li, Chung-Li Dist., Taoyuan City 320, Taiwan (R.O.C.)

TEST REPORT

Reference No. : A20092502

Report No. : FCCA20092502

FCC ID : 2AXURX5003

Page : 30 of 34

Date : Jan. 02, 2021

Above 2483.5 MHz (G_CH01)

Antenna Polarization : Horizontal

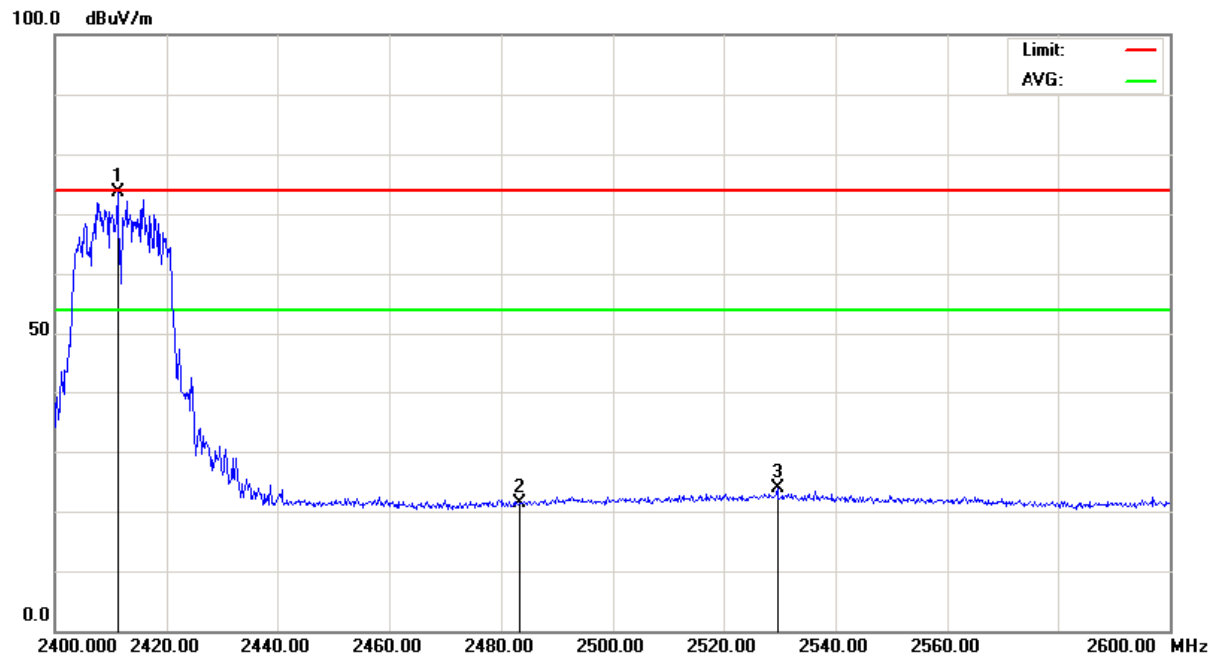

Antenna Polarization : Vertical

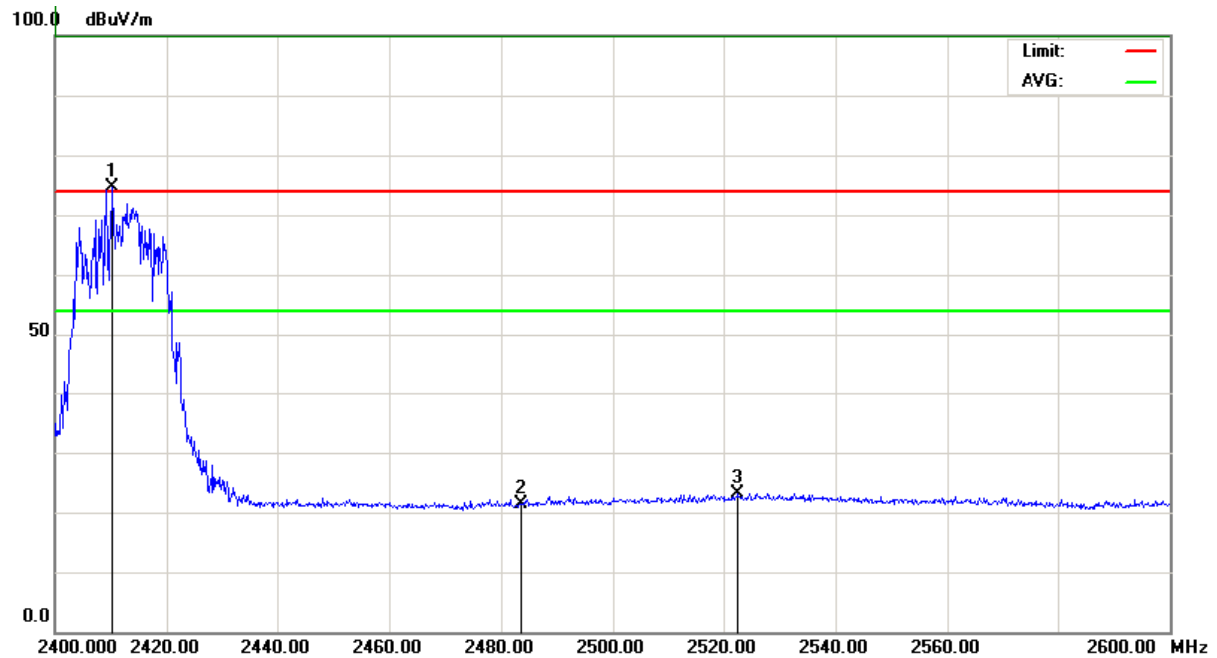



Spectrum Research & Testing Lab., Inc.

No.167, Ln. 780, Shan-Tong Rd., Ling 8, Shan-Tong Li, Chung-Li Dist., Taoyuan City 320, Taiwan (R.O.C.)

TEST REPORT

Reference No. : A20092502
Report No. : FCCA20092502
FCC ID : 2AXURX5003
Page : 31 of 34
Date : Jan. 02, 2021

4.6 POWER SPECTRAL DENSITY TEST

4.6.1 LIMIT

FCC Part15, Subpart C Section 15.247(e).

For digitally modulated systems, the power spectral density conducted from the intentional radiator to the antenna shall not be greater than 8 dBm in any 3 kHz band during any time interval of continuous transmission.

FREQUENCY RANGE	LIMIT
2.40 GHz – 2.4835 GHz	8 dBm / 3 kHz

4.6.2 TEST EQUIPMENT

The following test equipment was used during the test :

EQUIPMENT/ FACILITIES	SPECIFICATIONS	MANUFACTURER	MODEL#/ SERIAL#	DUE DATE OF CAL. & CAL. CENTER
EMI TEST RECEIVER (INCLUDE SPECTRUM ANALYZER)	9 KHz ~ 6 GHz	ROHDE & SCHWARZ	ESL /100176	JUL. 30, 2021 ETC

NOTE: The calibration interval of the above test equipment is one year and the calibrations are traceable to NML/ROC and NIST/USA.

4.6.3 TEST SET-UP

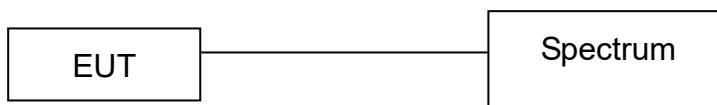

The EUT was connected to a spectrum through a 50Ω RF cable.

4.6.4 TEST PROCEDURE

The EUT was operating in transmitter mode and could be controlled its channel.

Print out the test result by printing function on the spectrum.

4.6.5 EUT OPERATING CONDITION

1. Set the EUT under continuous transmission condition.
2. The EUT was set to the highest available power level.



Spectrum Research & Testing Lab., Inc.

No.167, Ln. 780, Shan-Tong Rd., Ling 8, Shan-Tong Li, Chung-Li Dist., Taoyuan City 320, Taiwan (R.O.C.)

TEST REPORT

Reference No. : A20092502
Report No. : FCCA20092502
FCC ID : 2AXURX5003
Page : 32 of 34
Date : Jan. 02, 2021

4.6.6 TEST RESULT

Temperature:	24 °C	Humidity:	79 %RH
Detector:	RMS	Tested mode:	802.11g
RBW:	3 kHz	VBW:	10 kHz
Tested By:	David Hung	Tested Date:	Oct. 13, 2020

Channel Number	Channel Frequency (MHz)	Power Spectral Density (dBm/3kHz)	Maximum Limit (dBm/3kHz)
CH01	2412	-34.14	8

G_CH01 :

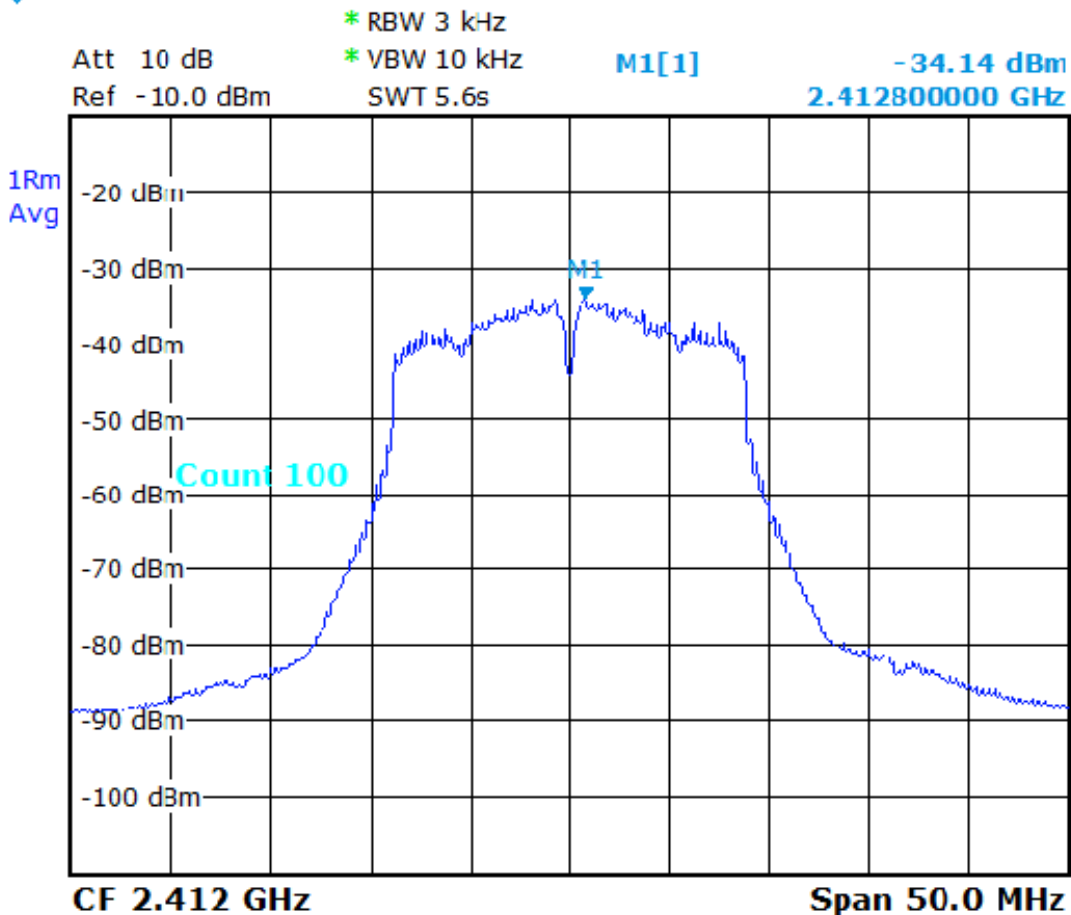



Spectrum Research & Testing Lab., Inc.

No.167, Ln. 780, Shan-Tong Rd., Ling 8, Shan-Tong Li, Chung-Li Dist., Taoyuan City 320, Taiwan (R.O.C.)

TEST REPORT

Reference No. : A20092502
Report No. : FCCA20092502
FCC ID : 2AXURX5003
Page : 33 of 34
Date : Jan. 02, 2021

5. Antenna application

5.1 Antenna requirement

The EUT's antenna is met the requirement of FCC Part 15C section 15.203 and 15.204.

FCC Part 15C section 15.247 requirement:

Systems operating in the 2400-2483.5 MHz band that are used exclusively for fixed, point-to-point operations may employ transmitting antennas with directional gain greater than 6 dBi provided the maximum peak output power of the intentional radiator is reduced by 1 dB for every 3 dB that the directional gain of the antenna exceeds 6 dBi.

5.2 Result

The EUT's antenna used a Chip Antenna (Brand : RainSun Model : AN1003). Gain of 1.5 dBi that meet the requirement.



Spectrum Research & Testing Lab., Inc.

No.167,Ln. 780, Shan-Tong Rd.,Ling 8, Shan-Tong Li, Chung-Li Dist., Taoyuan City 320, Taiwan (R.O.C.)

TEST REPORT

Reference No. : A20092502
Report No. : FCCA20092502
FCC ID : 2AXURX5003
Page : 34 of 34
Date : Jan. 02, 2021

6. TERMS OF ABBREVIATION

AV.	Average detection
AZ(°)	Turn table azimuth
Correct.	Correction
EL(m)	Antenna height (meter)
EUT	Equipment Under Test
Horiz.	Horizontal direction
LISN	Line Impedance Stabilization Network
NSA	Normalized Site Attenuation
Q.P.	Quasi-peak detection
SRT Lab	Spectrum Research & Testing Laboratory, Inc.
Vert.	Vertical direction