

# FCC CFR47 PART 22H, 24E, 27 CERTIFICATION TEST REPORT

## FCC ID: 2AXUI-103S

**Product:** 4G TABLET PC

**Trade Mark:** hatch

**Model Number:** 103S

**Family Model:** N/A

**Report No.:** STR220923002006E

### Prepared for

CHITECH SHENZHEN TECHNOLOGY CO.,LTD

101, NO.48, Xiashijia Road, Gongming Town, Guangming Dist., Shenzhen, China

### Prepared by

Shenzhen NTEK Testing Technology Co., Ltd.

1/F, Building E, Fenda Science Park, Sanwei Community, Xixiang Street

Bao'an District, Shenzhen 518126 P.R. China

Tel. 400-800-6106, 0755-2320 0050, 0755-2320 0090

Website:<http://www.ntek.org.cn>

<b>TEST RESULT CERTIFICATION</b>	
<b>Applicant's name</b> .....	CHITECH SHENZHEN TECHNOLOGY CO.,LTD
<b>Address</b> .....	101, NO.48, Xiashijia Road, Gongming Town, Guangming Dist., Shenzhen, China
<b>Manufacturer's Name</b> .....	CHITECH SHENZHEN TECHNOLOGY CO.,LTD
<b>Address</b> .....	101, NO.48, Xiashijia Road, Gongming Town, Guangming Dist., Shenzhen, China
<b>Product name</b> .....	4G TABLET PC
<b>Model and/or type reference</b> .....	103S
<b>Family Model:</b>	N/A
<b>Standards</b> .....	FCC CFR 47 Part 22H, Part 24E, Part 27
<b>Test procedure</b> .....	ANSI C63.26:2015 ANSI/TIA-603-E-2016

This device described above has been tested by NTEK, and the test results show that the equipment under test (EUT) is in compliance with the FCC requirements. And it is applicable only to the tested sample identified in the report.

This report shall not be reproduced except in full, without the written approval of NTEK, this document may be altered or revised by NTEK, personal only, and shall be noted in the revision of the document.

<b>Test Sample Number</b> .....	T220923002R002
<b>Date of Test</b> .....	
<b>Date (s) of performance of tests</b> .....	Sep 28, 2022 ~ Nov 02, 2022
<b>Date of Issue</b> .....	Nov 02, 2022
<b>Test Result</b> .....	<b>Pass</b>

Testing Engineer :   
 \_\_\_\_\_  
 (Allen Liu)

Authorized Signatory :   
 \_\_\_\_\_  
 (Alex Li)

## TABLE OF CONTENTS

1.1 PRODUCT DESCRIPTION .....	5
1.2 RELATED SUBMITTAL(S) / GRANT (S) .....	6
1.3 TEST METHODOLOGY .....	6
1.4 TEST FACILITY .....	6
MEASUREMENT UNCERTAINTY .....	6
1.5 SPECIAL ACCESSORIES.....	6
1.6 WORST-CASE CONFIGURATION AND MODE.....	7
1.6 SUMMARY OF TEST RESULTS .....	7
2. SYSTEM TEST CONFIGURATION .....	9
2.1 EUT CONFIGURATION.....	9
2.2 EUT EXERCISE .....	9
2.3 CONFIGURATION OF EUT SYSTEM.....	9
2.4 TEST SETUP .....	10
3.TEST AND MEASUREMENT EQUIPMENT .....	11
4. OUTPUT POWER.....	13
4.1 OUTPUT POWER MEASUREMENT .....	13
6. BANDEDGE AND EMISSION MASK.....	16
7. OUT OF BAND EMISSIONS .....	17
7.1 MEASUREMENT METHOD .....	18
8. RADIATED MEASUREMENT .....	19
8.1. RADIATED POWER (ERP & EIRP).....	19
8.2 LTE BAND 2.....	20
8.3 LTE BAND 4.....	24
8.4 LTE BAND 5.....	28
9. SPURIOUS RADIATION EMISSION .....	30

**9.1 LTE BAND 2..... 32**

**9.2 LTE BAND 4..... 34**

**9.3 LTE BAND 5..... 36**

**10. FREQUENCY STABILITY .....38**

**10.1 LTE BAND 2 ..... 39**

**10.2 LTE BAND 4 ..... 41**

**10.3 LTE BAND 5 ..... 43**

**11. PEAK-TO-AVERAGE RATIO.....45**

**11.1 Description of the PAR Measurement..... 45**

**11.2 Measuring Instruments ..... 45**

**11.3 Test Procedures..... 45**

**11.4 Test Setup..... 45**

## 1. GENERAL INFORMATION

### 1.1 PRODUCT DESCRIPTION

A major technical description of EUT is described as following:

Product Designation:	4G TABLET PC
Trade Mark	hatch
Model Name	103S
Family Model	N/A
Model Difference	N/A
FCC ID:	2AXUI-103S
Frequency Bands:	U.S. Bands: <input checked="" type="checkbox"/> LTE FDD Band 2, 4, 5
Frequency Range:	LTE FDD Band 2 Uplink: 1850MHz-1910MHz, Downlink: 1930MHz-1990MHz; LTE FDD Band 4 Uplink: 1710MHz-1755MHz, Downlink: 2110MHz-2155MHz; LTE FDD Band 5 Uplink: 824MHz-849MHz, Downlink: 869MHz-894MHz;
Type of Modulation:	QPSK/16QAM
Power Class	Class 3
Antenna:	PIFA Antenna
Antenna gain:	Band 2: 0.41dBi, Band 4: 0.41dBi, Band 5: -1.86dBi
Adapter	MODEL: AS1201A-0502000USU INPUT: 100-240V~50/60Hz 0.35A MAX OUTPUT: 5V $\overline{\text{---}}$ 2000mA
Battery	DC 3.7V, 8000mAh
Power supply	DC 3.7V from battery or DC 5V from Adapter.
Extreme Vol. Limits:	DC 3.4V to DC 4.2V (Nominal DC 3.7V) (Note 1)
HW Version	H106_MB_V3.0_20210718
SW Version	ignite.Q0.V9.33.2.RC-V39.8788.128.MP4
** Note1: The High Voltage 4.2V and Low Voltage 3.4V was declared by manufacturer, The EUT couldn't be operate normally with higher or lower voltage.	

## 1.2 RELATED SUBMITTAL(S) / GRANT (S)

This submittal(s) (test report) is intended for **FCC ID: 2AXUI-103S** filing to comply with the FCC Part 22H&24E &27.

## 1.3 TEST METHODOLOGY

The tests documented in this report were performed in accordance with ANSI/TIA-603-E-2016, FCC CFR 47 Part 2, Part 22, Part 24, Part 27, ANSI C63.26:2015.

## 1.4 TEST FACILITY

The test site used to collect the radiated data is located at:

ShenZhen NTEK Testing Technology Co., Ltd.

1/F, Building E, Fenda Science Park, Sanwei Community, Xixiang Street, Bao'an District, Shenzhen 518126 P.R.China.

The test site is constructed and calibrated to meet the FCC requirements in documents ANSI C63.26:2015& ANSI C63.4: 2014.

FCC Registration No.:463705

IC Registration No.:9270A-1,

CNAS Registration No.:L5516

## MEASUREMENT UNCERTAINTY

The reported uncertainty of measurement, where expended uncertainty U is based on a standard uncertainty multiplied by a coverage factor of k=2, providing a level of confidence of approximately 95 %.

No.	Item	Uncertainty
1	Measuring Uncertainty for a Level of Confidence of 95% ( $U = 2Uc(y)$ )	2.5dB
2	Conducted Emission Test	$\pm 1.38$ dB
3	RF power, conducted	$\pm 0.16$ dB
4	Spurious emissions, conducted	$\pm 0.21$ dB
5	All emissions, radiated(<1G)	$\pm 4.68$ dB
6	All emissions, radiated(>1G)	$\pm 4.89$ dB
7	Temperature	$\pm 0.5$ °C
8	Humidity	$\pm 2$ %
9	Frequency error, conducted	$\pm 0.19$ ppm

## 1.5 SPECIAL ACCESSORIES

The battery and the charger, earphone supplied by the applicant were used as accessories and being tested with EUT intended for FCC grant together.

### 1.6 WORST-CASE CONFIGURATION AND MODE

The worst-case scenario for all measurements is based on the investigation results.

The device has LTE Bands of: Band 2, Band 4, Band 5

The RB Size was selected to measure for peak or average ERP and EIRP, which was based on the conducted power verification baseline data.

For the fundamental investigation of radiated emissions, the EUT is investigated for vertical and horizontal antenna orientations and X Y and Z orientations of the EUT alone. After the investigations the worst case was determined to be at X orientation for all LTE bands.

### 1.6 SUMMARY OF TEST RESULTS

FCC Part22, Subpart H/ FCC Part24, Subpart E, FCC Part27, Subpart L, KDB 971168 D01 Power Meas License Digital Systems v03			
FCC Rule	Test Item	Verdict	Remark
2.1046	Conducted Output Power	PASS	
22.913(d) 24.232(d) 27.50(d)(5) KDB 971168 D01 Clause 5.7	Peak-to-Average Ratio	PASS	
2.1049 22.917(b) 24.238(b) KDB 971168 D01 Clause 4.2	Occupied Bandwidth	PASS	
2.1051 22.917(a) 24.238(a) 27.53(m), (g), (h) KDB 971168 D01 Clause 6	Band Edge	PASS	
22.913(a)(2) 27.50(c)(10) KDB 971168 D01 Clause 5.6	Effective Radiated Power	PASS	
24.232(c) 27.50(h)(2), (d)(4) KDB 971168 D01 Clause 5.6	Equivalent Isotropic Radiated Power	PASS	

2.1053 22.917(a) 24.238(a) 27.53(g)(h)(m) KDB 971168 D01 Clause 7	Field Strength of Spurious Radiation	PASS	
2.1055 22.355 24.235 27.54 KDB 971168 D01 Clause 9	Frequency Stability for Temperature & Voltage	PASS	
2.1051 22.917(a) 24.238(a) 27.53(g)(h)(m) KDB 971168 D01 Clause 6	Conducted Emission	PASS	

Remark:

1. "N/A" denotes test is not applicable in this Test Report.
2. All test items were verified and recorded according to the standards and without any deviation during the test.
3. No modifications are made to the EUT during all test items.



## 2. SYSTEM TEST CONFIGURATION

### 2.1 EUT CONFIGURATION

The EUT configuration for testing is installed on RF field strength measurement to meet the Commission's requirement and operating in a manner which intends to maximize its emission characteristics in a continuous normal application.

### 2.2 EUT EXERCISE

The Transmitter was operated in the maximum output power mode through Communication Tester. The TX frequency was fixed which was for the purpose of the measurements.

### 2.3 CONFIGURATION OF EUT SYSTEM

Table 2-1 Equipment Used in EUT System

Item	Equipment	Model No.	ID or Specification	Note
1	4G TABLET PC	103S	FCC ID: 2AXUI-103S	EUT

*Note: All the accessories have been used during the test.  
the following "EUT" in setup diagram means EUT system.*

## 2.4 TEST SETUP

For Radiated Test Cases

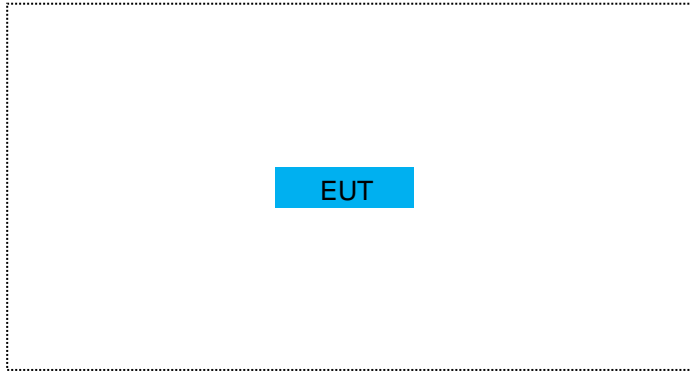

For Conducted Output Power

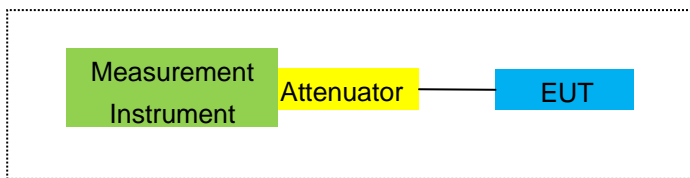

For Peak-to Average Ratio, Occupied Bandwidth, Conducted Band edge and Conducted Spurious Emission

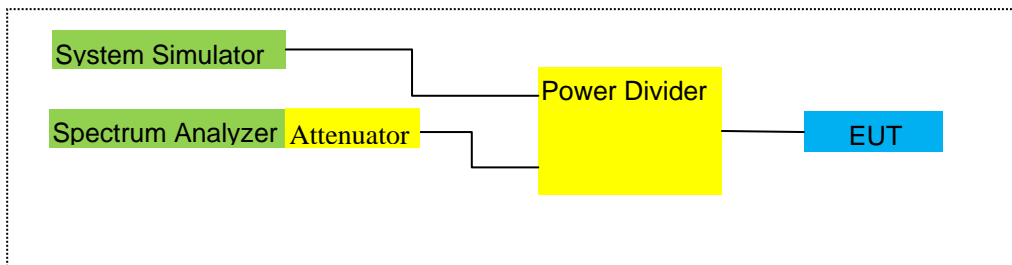

For Frequency Stability

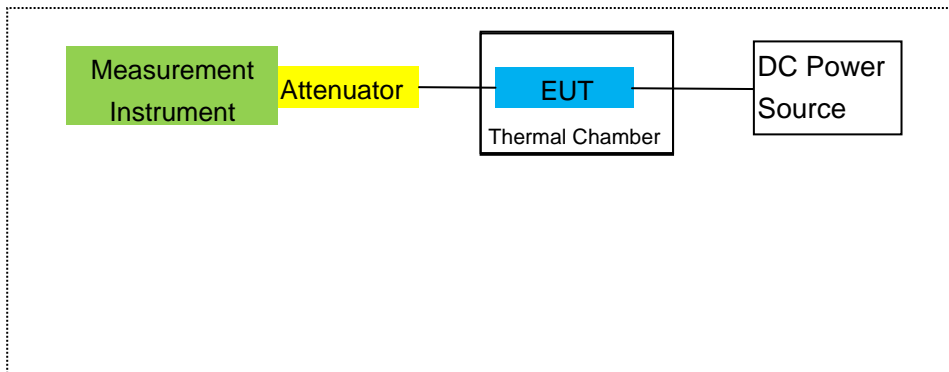

Note: EUT built-in battery-powered, the battery is fully-charged.

### 3. TEST AND MEASUREMENT EQUIPMENT

The following test and measurement equipment was utilized for the tests documented in this report:

Item	Kind of Equipment	Manufacturer	Type No.	Serial No.	Last calibration	Calibrated until	Calibration period
1	MXA Signal Analyzer	Agilent	N9020A	MY49100060	2022.04.06	2023.04.05	1 year
2	Test Receiver	R&S	ESPI	101318	2022.04.06	2023.04.05	1 year
3	Bilog Antenna	TESEQ	CBL6111D	31216	2022.03.30	2023.03.29	1 year
4	50Ω Coaxial Switch	Anritsu	MP59B	6200983705	2020.05.11	2023.05.10	3 year
5	Horn Antenna	EM	EM-AH-10180	2011071402	2022.03.31	2023.03.30	1 year
6	Horn Ant	Schwarzbeck	BBHA 9170	9170-181	2021.11.07	2022.11.06	1 year
7	Amplifier	EM	EM-30180	060538	2022.06.17	2023.06.16	1 year
8	Loop Antenna	ARA	PLA-1030/B	1029	2022.04.06	2023.04.05	1 year
9	Power Meter	R&S	NRVS	100696	2022.06.17	2023.06.16	1 year
10	Power Sensor	R&S	URV5-Z4	0395.1619.05	2022.04.06	2023.04.05	1 year
11	Test Cable	N/A	R-01	N/A	2020.05.11	2023.05.10	3 year
12	Test Cable	N/A	R-02	N/A	2020.05.11	2023.05.10	3 year
13	Test Cable	N/A	R-03	N/A	2022.06.17	2025.06.16	3 year
14	Test Receiver	R&S	ESCI	101160	2022.04.06	2023.04.05	1 year
15	LISN	R&S	ENV216	101313	2022.04.06	2023.04.05	1 year
16	LISN	EMCO	3816/2	00042990	2022.04.06	2023.04.05	1 year
17	50Ω Coaxial Switch	Anritsu	MP59B	6200264417	2022.04.06	2023.04.05	1 year
18	Passive Voltage Probe	R&S	ESH2-Z3	100196	2022.04.06	2023.04.05	1 year
19	Test Cable	N/A	C01	N/A	2020.05.11	2023.05.10	3 year
20	Test Cable	N/A	C02	N/A	2020.05.11	2023.05.10	3 year
21	Test Cable	N/A	C03	N/A	2020.05.11	2023.05.10	3 year
22	Attenuator	MCE	24-10-34	BN9258	2022.06.17	2023.06.16	1 year
23	Spectrum Analyzer	agilent	e4440a	us44300399	2022.04.06	2023.04.05	1 year
24	test receiver	R&S	ESCI	a0304218	2022.04.06	2023.04.05	1 year
25	Communication Tester	R&S	CMU200	A0304247	2022.06.17	2023.06.16	1 year

26	Thermal Chamber	Ten Billion	TTC-B3C	TBN-960502	2022.04.06	2023.04.05	1 year
27	DC Power Source	N/A	PS-6005D	2017040292 3	2020.05.11	2023.05.10	3 year
28	PSG Analog Signal Generator	Agilent	E8257D	MY51110112	2022.06.16	2023.06.15	1 year
29	Communication Tester	R&S	CMW500	148500	2022.06.16	2023.06.15	1 year

Note: Each piece of equipment is scheduled for calibration once a year except the Test Cable& DC Power Source which is scheduled for calibration every 3 years.

## 4. OUTPUT POWER

### 4.1 OUTPUT POWER MEASUREMENT

#### LTE Measurement Procedure:

All LTE bands conducted power peak and average are obtained from the CMW500 telecommunication test set. The following tests were conducted according to the test requirements outlined in section 6.2 of the 3GPP TS36.101 specification.

UE Power Class: 3 (23 +/- 2dBm). The allowed Maximum Power Reduction (MPR) for the maximum output power due to higher order modulation and transmit bandwidth configuration (resource blocks) is specified in Table 6.2.3-1 of the 3GPP TS36.101.

**Table 6.2.3-1: Maximum Power Reduction (MPR) for Power Class 3**

Modulation	Channel bandwidth / Transmission bandwidth (RB)						MPR (dB)
	1.4 MHz	3.0 MHz	5 MHz	10 MHz	15 MHz	20 MHz	
QPSK	> 5	> 4	> 8	> 12	> 16	> 18	≤ 1
16 QAM	≤ 5	≤ 4	≤ 8	≤ 12	≤ 16	≤ 18	≤ 1
16 QAM	> 5	> 4	> 8	> 12	> 16	> 18	≤ 2

The allowed A-MPR values specified below in Table 6.2.4.-1 of 3GPP TS36.101 are in addition to the allowed MPR requirements. All the measurements below were performed with A-MPR disabled, by using Network Signaling Value of "NS\_01".3

**Table 6.2.4-1: Additional Maximum Power Reduction (A-MPR)**

Network Signalling value	Requirements (sub-clause)	E-UTRA Band	Channel bandwidth (MHz)	Resources Blocks ( $N_{RB}$ )	A-MPR (dB)
NS_01	6.6.2.1.1	Table 5.5-1	1.4, 3, 5, 10, 15, 20	Table 5.6-1	NA
NS_03	6.6.2.2.1	2, 4, 10, 23, 25, 35, 36	3	>5	$\leq 1$
			5	>6	$\leq 1$
			10	>6	$\leq 1$
			15	>8	$\leq 1$
			20	>10	$\leq 1$
NS_04	6.6.2.2.2	41	5	>6	$\leq 1$
			10, 15, 20	See Table 6.2.4-4	
NS_05	6.6.3.3.1	1	10, 15, 20	$\geq 50$	$\leq 1$
NS_06	6.6.2.2.3	12, 13, 14, 17	1.4, 3, 5, 10	Table 5.6-1	n/a
NS_07	6.6.2.2.3	13	10	Table 6.2.4-2	Table 6.2.4-2
	6.6.3.3.2				
NS_08	6.6.3.3.3	19	10, 15	> 44	$\leq 3$
NS_09	6.6.3.3.4	21	10, 15	> 40	$\leq 1$
				> 55	$\leq 2$
NS_10		20	15, 20	Table 6.2.4-3	Table 6.2.4-3
NS_11	6.6.2.2.1	23 <sup>1</sup>	1.4, 3, 5, 10	Table 6.2.4-5	Table 6.2.4-5
..					
NS_32	-	-	-	-	-

Note 1: Applies to the lower block of Band 23, i.e. a carrier placed in the 2000-2010 MHz region.

Test data reference attachment.

## 5. OCCUPIED BANDWIDTH

### RULE PART(S)

FCC: §2.1049

### LIMITS

For reporting purposes only

### TEST PROCEDURE

The transmitter output was connected to a calibrated coaxial cable and coupler, the other end of which was connected to a spectrum analyzer. The occupied bandwidth was measured with the spectrum analyzer at the low, middle and high channel in each band. The -26dB bandwidth was also measured and recorded.

### MODES TESTED

- LTE Band2
- LTE Band 4
- LTE Band 5

### RESULTS

**PASS**

Test data reference attachment.

## 6. BANDEDGE AND EMISSION MASK

### RULE PART(S)

FCC: §2.1051, §22.917(a), §24.238(a), §27.53(c)(g)(h)(m)

FCC: §2.1046, §22.913, §24.232

### LIMITS

The minimum permissible attenuation level of any spurious emission is  $43 + \log_{10}(P[\text{Watts}])$ , where P is the transmitter power in Watts.

The minimum permissible attenuation level for Band 7 is as following.

Per 27.53(g) for operations in the 698-746 MHz band, in the 100 kHz bands immediately outside and adjacent to the frequency block a resolution bandwidth of at least 30 kHz may be employed to demonstrate compliance with the out-of-band emissions limit.

Per 27.53(c.5) for operations in the 776-788 MHz band, in the 100 kHz bands immediately outside and adjacent to the frequency block a resolution bandwidth of at least 30 kHz may be employed to demonstrate compliance with the out-of-band emissions limit.

For all plots showing emissions in the 763 – 775MHz and 793 – 805MHz band, the FCC limit per 27.53(c.4) is  $65 + 10\log_{10}(P) = -35\text{dBm}$  in a 6.25kHz bandwidth.

Per 27.53(m) for operations in the BRS/EBS bands, the attenuation factor shall be not less than  $40 + 10 \log (P)$  dB on all frequencies between the channel edge and 5 megahertz from the channel edge,  $43 + 10 \log (P)$  dB on all frequencies between 5 megahertz and X megahertz from the channel edge, and  $55 + 10 \log (P)$  dB on all frequencies more than X megahertz from the channel edge, where X is the greater of 6 megahertz or the actual emission bandwidth.

### TEST PROCEDURE

The transmitter output was connected to a CMW500Test Set and configured to operate at maximum power. The band edge emissions were measured at the required operating frequencies in each band on the Spectrum Analyzer.

For each band edge measurement:

Set the spectrum analyzer span to include the block edge frequency

Set a marker to point the corresponding band edge frequency in each test case.

Set display line

Set resolution bandwidth to at least 1% of emission bandwidth.

### MODES TESTED

- LTE Band 2/4/5

### RESULTS

Test data reference attachment.



## 7. OUT OF BAND EMISSIONS

### RULE PART(S)

FCC: §2.1051, §22.917(a), §24.238(a), §27.53(c)(g)(h)(m)

### LIMITS

The minimum permissible attenuation level of any spurious emission is  $43 + \log_{10}(P[\text{Watts}])$ , where P is the transmitter power in Watts.

The minimum permissible attenuation level for Band 7 is as following.

Per 27.53(g) for operations in the 698-746 MHz band, in the 100 kHz bands immediately outside and adjacent to the frequency block a resolution bandwidth of at least 30 kHz may be employed to demonstrate compliance with the out-of-band emissions limit.

Per 27.53(c.5) for operations in the 776-788 MHz band, in the 100 kHz bands immediately outside and adjacent to the frequency block a resolution bandwidth of at least 30 kHz may be employed to demonstrate compliance with the out-of-band emissions limit.

For all plots showing emissions in the 763 – 775MHz and 793 – 805MHz band, the FCC limit per 27.53(c.4) is  $65 + 10\log_{10}(P) = -35\text{dBm}$  in a 6.25kHz bandwidth.

Per 27.53(m) for operations in the BRS/EBS bands, the attenuation factor shall be not less than  $40 + 10 \log (P)$  dB on all frequencies between the channel edge and 5 megahertz from the channel edge,  $43 + 10 \log (P)$  dB on all frequencies between 5 megahertz and X megahertz from the channel edge, and  $55 + 10 \log (P)$  dB on all frequencies more than X megahertz from the channel edge, where X is the greater of 6 megahertz or the actual emission bandwidth.

### TEST PROCEDURE

The RF output of the transmitter was connected to a spectrum analyzer through a calibrated coaxial cable. Sufficient scans were taken to show the out-of-band Emissions, if any, up to 10th harmonic. Multiple sweeps were recorded in maximum hold mode using a peak detector to ensure that the worst-case emissions were caught.

For each out of band emissions measurement:

- Set display line
- Set RBW & VBW to 100 kHz for the measurement below 1 GHz, and 1 MHz for the measurement above 1 GHz.

### MODES TESTED

- LTE Band2
- LTE Band 4
- LTE Band 5

## 7.1 MEASUREMENT METHOD

The test set up and general procedure is similar to conducted peak output power test. Only different for setting the measurement configuration of the measuring instrument of Spectrum Analyzer.

### **Test data reference attachment.**

Note: the amplitude of spurious emission that is attenuated by more than 20dB below the permissible limit has no need to be reported (LTE Band 2/4: above 10GHz).

## 8. RADIATED MEASUREMENT

### 8.1. RADIATED POWER (ERP & EIRP)

#### RULE PART(S)

FCC: §2.1046, §22.913(a)(2), §24.232(c) and §27.50 (h)(2), (b)(10), (c)(10), (d)(4)

#### LIMITS:

22.913(a) (2)- The ERP of mobile transmitters and auxiliary test transmitters must not exceed 7 Watts.  
24.232 (c) Mobile and portable stations are limited to 2 watts EIRP.  
27.50 (c) (10) the following power and antenna height requirements apply to stations transmitting in the 698–746 MHz band, the portable stations (hand-held devices) are limited to 3 watts ERP.  
27.50 (b)(10) Portable stations (hand-held devices) transmitting in the 746–757 MHz, 758–763 MHz, 776–793 MHz, and 805–806 MHz bands are limited to 3 watts ERP.  
27.50 (d)(4) The following power and antenna height requirements apply to stations transmitting in the 1710–1755 MHz and 2110–2155 MHz bands: Fixed, mobile, and portable (hand-held) stations operating in the 1710–1755 MHz band are limited to 1 watt EIRP.  
27.50 (h)(2) Mobile and other user stations in the 2500–2570 MHz and 2620–2690 MHz bands. Mobile stations are limited to 2.0 watts EIRP. All user stations are limited to 2.0 watts transmitter output power.

#### TEST PROCEDURE

ANSI/TIA-603-E Clause 2.2.17

KDB 971168 v02r01 RF power output using broadband peak and average power meter method.

KDB 971168 D01 Power Meas License Digital Systems v02r01, “Measurement Guidance for Certification of Licensed Digital Transmitters”

#### MODES TESTED

- LTE Band2
- LTE Band 4
- LTE Band 5

#### RESULTS

Pass

## 8.2 LTE BAND 2

Radiated Power (EIRP) for Band 2														
Mode	RB/RB SIZE	Frequency	Result					Polarization Of Max. ERP	Conclusion					
			SG Level (dBm)	Cable Loss (dBm)	Antenna Factor (dB)	Max. EIRP Average (dBm)	Max. EIRP Average (mW)							
			1.4MHz	1/#Mid	1850.7	-2.97	3.76			28.24	21.51	141.579	Horizontal	Pass
			Band		1880	-2.78	3.91			28.22	21.53	142.233	Horizontal	Pass
QPSK	1909.3	-2.69	3.93		28.20	21.58	143.880	Horizontal	Pass					
3.0MHz	1/#Mid	1851.5	-3.03	3.77	28.23	21.43	138.995	Horizontal	Pass					
Band		1880	-2.88	3.91	28.24	21.45	139.637	Horizontal	Pass					
QPSK		1908.5	-2.75	3.94	28.25	21.56	143.219	Horizontal	Pass					
5.0MHz	1/#Mid	1852.5	-2.92	3.77	28.31	21.62	145.211	Horizontal	Pass					
Band		1880	-2.54	3.91	28.22	21.77	150.314	Horizontal	Pass					
QPSK		1907.5	-2.47	3.94	28.20	21.79	151.008	Horizontal	Pass					
10.0MHz	1/#Mid	1855	-2.78	3.79	28.33	21.76	149.968	Horizontal	Pass					
Band		1880	-2.48	3.95	28.22	21.79	151.008	Horizontal	Pass					
QPSK		1905	-2.37	3.97	28.19	21.85	153.109	Horizontal	Pass					
15.0MHz	1/#Mid	1857.5	-2.74	3.79	28.34	21.81	151.705	Horizontal	Pass					
Band		1880	-2.53	3.95	28.22	21.74	149.279	Horizontal	Pass					
QPSK		1902.5	-2.39	3.97	28.18	21.82	152.055	Horizontal	Pass					
20.0MHz	1/#Mid	1860	-2.73	3.81	28.35	21.81	151.705	Horizontal	Pass					
Band		1880	-2.40	3.96	28.22	<b>21.86</b>	153.462	Horizontal	Pass					
QPSK		1900	-2.34	4.00	28.16	21.82	152.055	Horizontal	Pass					
1.4MHz	1/#Mid	1850.7	-4.03	3.76	28.24	20.45	110.917	Vertical	Pass					
Band		1880	-3.28	3.91	28.22	21.03	126.765	Vertical	Pass					
QPSK		1909.3	-3.27	3.93	28.20	21.00	125.893	Vertical	Pass					
3.0MHz	1/#Mid	1851.5	-3.45	3.77	28.23	21.01	126.183	Vertical	Pass					
Band		1880	-3.72	3.91	28.24	20.61	115.080	Vertical	Pass					
QPSK		1908.5	-3.74	3.94	28.25	20.57	114.025	Vertical	Pass					
5.0MHz	1/#Mid	1852.5	-3.76	3.77	28.31	20.78	119.674	Vertical	Pass					
Band		1880	-3.92	3.91	28.22	20.39	109.396	Vertical	Pass					
QPSK		1907.5	-4.01	3.94	28.20	20.25	105.925	Vertical	Pass					
10.0MHz	1/#Mid	1855	-4.00	3.79	28.33	20.54	113.240	Vertical	Pass					
Band		1880	-3.18	3.95	28.22	21.09	128.529	Vertical	Pass					
QPSK		1905	-3.79	3.97	28.19	20.43	110.408	Vertical	Pass					

15.0MHz		1857.5	-4.16	3.79	28.34	20.39	109.396	Vertical	Pass
Band	1/#Mid	1880	-3.99	3.95	28.22	20.28	106.660	Vertical	Pass
QPSK		1902.5	-3.97	3.97	28.18	20.24	105.682	Vertical	Pass
20.0MHz		1860	-3.37	3.81	28.35	21.17	130.918	Vertical	Pass
Band	1/#Mid	1880	-3.18	3.96	28.22	21.08	128.233	Vertical	Pass
QPSK		1900	-3.53	4.00	28.16	20.63	115.611	Vertical	Pass

Note:

SG Level= Signal generator output

Max. EIRP Average (dBm)= Antenna Factor (dB)+ SG Level (dBm)- Cable Loss(dBm)

Radiated Power (EIRP) for Band 2									
Mode	RB/RB SIZE	Frequency	Result						Conclusion
			SG Level (dBm)	Cable Loss (dBm)	Antenna Factor (dB)	Max. EIRP Average (dBm)	Max. EIRP Average	Polarization Of Max. ERP	
1.4MHz Band 16 QAM	1/#Mid	1850.7	-4.09	3.76	28.24	20.39	109.396	Horizontal	Pass
		1880	-3.56	3.91	28.22	20.75	118.850	Horizontal	Pass
		1909.3	-3.49	3.93	28.20	20.78	119.674	Horizontal	Pass
3.0MHz Band 16 QAM	1/#Mid	1851.5	-3.59	3.77	28.23	20.87	122.180	Horizontal	Pass
		1880	-3.67	3.91	28.24	20.66	116.413	Horizontal	Pass
		1908.5	-3.88	3.94	28.25	20.43	110.408	Horizontal	Pass
5.0MHz Band 16 QAM	1/#Mid	1852.5	-3.53	3.77	28.31	21.01	126.183	Horizontal	Pass
		1880	-3.44	3.91	28.22	20.87	122.180	Horizontal	Pass
		1907.5	-3.12	3.94	28.20	21.14	130.017	Horizontal	Pass
10.0MHz Band 16 QAM	1/#Mid	1855	-3.58	3.79	28.33	20.96	124.738	Horizontal	Pass
		1880	-3.57	3.95	28.22	20.70	117.490	Horizontal	Pass
		1905	-3.04	3.97	28.19	21.18	131.220	Horizontal	Pass
15.0MHz Band 16 QAM	1/#Mid	1857.5	-3.56	3.79	28.34	20.99	125.603	Horizontal	Pass
		1880	-3.35	3.95	28.22	20.92	123.595	Horizontal	Pass
		1902.5	-3.31	3.97	28.18	20.90	123.027	Horizontal	Pass
20.0MHz Band 16 QAM	1/#Mid	1860	-3.45	3.81	28.35	21.09	128.529	Horizontal	Pass
		1880	-3.15	3.96	28.22	21.11	129.122	Horizontal	Pass
		1900	-2.97	4.00	28.16	<b>21.19</b>	131.522	Horizontal	Pass
1.4MHz Band 16 QAM	1/#Mid	1850.7	-4.79	3.76	28.24	19.69	93.111	Vertical	Pass
		1880	-4.29	3.91	28.22	20.02	100.462	Vertical	Pass
		1909.3	-4.30	3.93	28.20	19.97	99.312	Vertical	Pass
3.0MHz Band 16 QAM	1/#Mid	1851.5	-5.01	3.77	28.23	19.45	88.105	Vertical	Pass
		1880	-4.81	3.91	28.24	19.52	89.536	Vertical	Pass
		1908.5	-4.16	3.94	28.25	20.15	103.514	Vertical	Pass
5.0MHz Band 16 QAM	1/#Mid	1852.5	-5.04	3.77	28.31	19.50	89.125	Vertical	Pass
		1880	-5.00	3.91	28.22	19.31	85.310	Vertical	Pass
		1907.5	-4.91	3.94	28.20	19.35	86.099	Vertical	Pass
10.0MHz Band 16 QAM	1/#Mid	1855	-4.67	3.79	28.33	19.87	97.051	Vertical	Pass
		1880	-4.99	3.95	28.22	19.28	84.723	Vertical	Pass
		1905	-4.74	3.97	28.19	19.48	88.716	Vertical	Pass
15.0MHz Band 16	1/#Mid	1857.5	-4.86	3.79	28.34	19.69	93.111	Vertical	Pass
		1880	-4.89	3.95	28.22	19.38	86.696	Vertical	Pass

QAM		1902.5	-4.57	3.97	28.18	19.64	92.045	Vertical	Pass
20.0MHz	1/#Mid	1860	-4.42	3.81	28.35	20.12	102.802	Vertical	Pass
Band 16		1880	-4.21	3.96	28.22	20.05	101.158	Vertical	Pass
QAM		1900	-4.13	4.00	28.16	20.03	100.693	Vertical	Pass

Note:

SG Level= Signal generator output

Max. EIRP Average (dBm)= Antenna Factor (dB)+ SG Level (dBm)- Cable Loss(dBm)

### 8.3 LTE BAND 4

Radiated Power (EIRP) for Band 4									
Mode	RB/RB SIZE	Frequency	Result					Polarization Of Max. ERP	Conclusion
			SG Level	Cable Loss	Antenna Factor	Max. EIRP	Max. EIRP		
			(dBm)	(dBm)	(dB)	Average	Average		
						(dBm)	(mW)		
1.4MHz Band QPSK	1/#Mid	1710.7	-2.88	3.12	27.58	21.58	143.880	Horizontal	Pass
		1732.5	-2.87	3.27	27.61	21.47	140.281	Horizontal	Pass
		1754.3	-2.85	3.29	27.63	21.49	140.929	Horizontal	Pass
3.0MHz Band QPSK	1/#Mid	1711.5	-3.05	3.13	27.61	21.43	138.995	Horizontal	Pass
		1732.5	-2.97	3.27	27.61	21.37	137.088	Horizontal	Pass
		1753.5	-2.89	3.30	27.62	21.43	138.995	Horizontal	Pass
5.0MHz Band QPSK	1/#Mid	1712.5	-2.82	3.13	27.63	21.68	147.231	Horizontal	Pass
		1732.5	-2.72	3.27	27.61	21.62	145.211	Horizontal	Pass
		1752.5	-2.60	3.30	27.60	21.70	147.911	Horizontal	Pass
10.0MHz Band QPSK	1/#Mid	1715	-2.76	3.15	27.64	21.73	148.936	Horizontal	Pass
		1732.5	-2.53	3.31	27.61	21.77	150.314	Horizontal	Pass
		1750	-2.55	3.33	27.59	21.71	148.252	Horizontal	Pass
15.0MHz Band QPSK	1/#Mid	1717.5	-2.77	3.15	27.65	21.73	148.936	Horizontal	Pass
		1732.5	-2.61	3.31	27.61	21.69	147.571	Horizontal	Pass
		1747.5	-2.55	3.33	27.57	21.69	147.571	Horizontal	Pass
20.0MHz Band QPSK	1/#Mid	1720	-2.71	3.17	27.66	<b>21.78</b>	150.661	Horizontal	Pass
		1732.5	-2.54	3.32	27.61	21.75	149.624	Horizontal	Pass
		1745	-2.48	3.36	27.56	21.72	148.594	Horizontal	Pass
1.4MHz Band QPSK	1/#Mid	1710.7	-3.88	3.12	27.58	20.58	114.288	Vertical	Pass
		1732.5	-3.38	3.27	27.61	20.96	124.738	Vertical	Pass
		1754.3	-3.53	3.29	27.63	20.81	120.504	Vertical	Pass
3.0MHz Band QPSK	1/#Mid	1711.5	-3.59	3.13	27.61	20.89	122.744	Vertical	Pass
		1732.5	-3.23	3.27	27.61	21.11	129.122	Vertical	Pass
		1753.5	-3.12	3.30	27.62	21.20	131.826	Vertical	Pass
5.0MHz Band QPSK	1/#Mid	1712.5	-3.73	3.13	27.63	20.77	119.399	Vertical	Pass
		1732.5	-3.99	3.27	27.61	20.35	108.393	Vertical	Pass
		1752.5	-3.24	3.30	27.60	21.06	127.644	Vertical	Pass
10.0MHz Band QPSK	1/#Mid	1715	-4.23	3.15	27.64	20.26	106.170	Vertical	Pass
		1732.5	-3.54	3.31	27.61	20.76	119.124	Vertical	Pass
		1750	-3.72	3.33	27.59	20.54	113.240	Vertical	Pass



15.0MHz Band QPSK	1/#Mid	1717.5	-3.52	3.15	27.65	20.98	125.314	Vertical	Pass
		1732.5	-3.86	3.31	27.61	20.44	110.662	Vertical	Pass
		1747.5	-3.69	3.33	27.57	20.55	113.501	Vertical	Pass
20.0MHz Band QPSK	1/#Mid	1720	-3.76	3.17	27.66	20.73	118.304	Vertical	Pass
		1732.5	-3.92	3.32	27.61	20.37	108.893	Vertical	Pass
		1745	-3.93	3.36	27.56	20.27	106.414	Vertical	Pass

**Note:**

SG Level= Signal generator output

Max. EIRP Average (dBm)= Antenna Factor (dB)+ SG Level (dBm)- Cable Loss(dBm)

Radiated Power (EIRP) for Band 4									
Mode	RB/RB SIZE	Frequency	Result						Conclusion
			SG Level	Cable	Antenna	Max. EIRP	Max. EIRP	Polarization	
			(dBm)	Loss	Factor	Average	Average	Of Max. ERP	
			(dBm)	(dB)	(dBm)	(mW)			
1.4MHz Band 16 QAM	1/#Mid	1710.7	-3.69	3.12	27.58	20.77	119.399	Horizontal	Pass
		1732.5	-3.54	3.27	27.61	20.80	120.226	Horizontal	Pass
		1754.3	-3.54	3.29	27.63	20.80	120.226	Horizontal	Pass
3.0MHz Band 16 QAM	1/#Mid	1711.5	-3.63	3.13	27.61	20.85	121.619	Horizontal	Pass
		1732.5	-3.76	3.27	27.61	20.58	114.288	Horizontal	Pass
		1753.5	-3.98	3.30	27.62	20.34	108.143	Horizontal	Pass
5.0MHz Band 16 QAM	1/#Mid	1712.5	-3.46	3.13	27.63	21.04	127.057	Horizontal	Pass
		1732.5	-3.42	3.27	27.61	20.92	123.595	Horizontal	Pass
		1752.5	-3.11	3.30	27.60	21.19	131.522	Horizontal	Pass
10.0MHz Band 16 QAM	1/#Mid	1715	-3.53	3.15	27.64	20.96	124.738	Horizontal	Pass
		1732.5	-3.72	3.31	27.61	20.58	114.288	Horizontal	Pass
		1750	-3.10	3.33	27.59	21.16	130.617	Horizontal	Pass
15.0MHz Band 16 QAM	1/#Mid	1717.5	-3.33	3.15	27.65	21.17	130.918	Horizontal	Pass
		1732.5	-3.39	3.31	27.61	20.91	123.310	Horizontal	Pass
		1747.5	-3.41	3.33	27.57	20.83	121.060	Horizontal	Pass
20.0MHz Band 16 QAM	1/#Mid	1720	-3.28	3.17	27.66	<b>21.21</b>	132.130	Horizontal	Pass
		1732.5	-3.29	3.32	27.61	21.00	125.893	Horizontal	Pass
		1745	-3.10	3.36	27.56	21.10	128.825	Horizontal	Pass
1.4MHz Band 16 QAM	1/#Mid	1710.7	-5.10	3.12	27.58	19.36	86.298	Vertical	Pass
		1732.5	-4.81	3.27	27.61	19.53	89.743	Vertical	Pass
		1754.3	-4.97	3.29	27.63	19.37	86.497	Vertical	Pass
3.0MHz Band 16 QAM	1/#Mid	1711.5	-4.67	3.13	27.61	19.81	95.719	Vertical	Pass
		1732.5	-4.82	3.27	27.61	19.52	89.536	Vertical	Pass
		1753.5	-4.14	3.30	27.62	20.18	104.232	Vertical	Pass
5.0MHz Band 16 QAM	1/#Mid	1712.5	-4.64	3.13	27.63	19.86	96.828	Vertical	Pass
		1732.5	-4.95	3.27	27.61	19.39	86.896	Vertical	Pass
		1752.5	-4.96	3.30	27.60	19.34	85.901	Vertical	Pass
10.0MHz Band 16 QAM	1/#Mid	1715	-4.42	3.15	27.64	20.07	101.625	Vertical	Pass
		1732.5	-4.42	3.31	27.61	19.88	97.275	Vertical	Pass
		1750	-4.57	3.33	27.59	19.69	93.111	Vertical	Pass
15.0MHz Band 16 QAM	1/#Mid	1717.5	-4.71	3.15	27.65	19.79	95.280	Vertical	Pass
		1732.5	-4.89	3.31	27.61	19.41	87.297	Vertical	Pass
		1747.5	-4.62	3.33	27.57	19.62	91.622	Vertical	Pass

20.0MHz		1720	-5.04	3.17	27.66	19.45	88.105	Vertical	Pass
Band 16	1/#Mid	1732.5	-4.13	3.32	27.61	20.16	103.753	Vertical	Pass
QAM		1745	-4.58	3.36	27.56	19.62	91.622	Vertical	Pass

Note:

SG Level= Signal generator output

Max. EIRP Average (dBm)= Antenna Factor (dB)+ SG Level (dBm)- Cable Loss(dBm)

### 8.4 LTE BAND 5

Radiated Power (ERP) for Band 5										
Mode	RB/RB SIZE	Frequency	Result							Conclusion
			SG Level	Cable Loss	Antenna Factor	Correction	Max. EIRP	Max. EIRP	Polarization	
			(dBm)	(dBm)	(dB)	(dB)	Average	Average	Of Max. ERP	
							(dBm)	(mW)		
1.4MHz Band QPSK	3/#Mid	824.7	6.53	2.01	19.68	2.15	22.05	160.325	Horizontal	Pass
		836.5	6.41	2.01	19.77	2.15	22.02	159.221	Horizontal	Pass
		848.3	6.21	2.02	19.82	2.15	21.86	153.462	Horizontal	Pass
3.0MHz Band QPSK	1/#Mid	825.5	6.30	2.01	19.70	2.15	21.84	152.757	Horizontal	Pass
		836.5	6.20	2.01	19.77	2.15	21.81	151.705	Horizontal	Pass
		847.5	6.07	2.02	19.81	2.15	21.71	148.252	Horizontal	Pass
5.0MHz Band QPSK	1/#Mid	826.5	6.58	2.01	19.71	2.15	22.13	163.305	Horizontal	Pass
		836.5	6.46	2.01	19.77	2.15	22.07	161.065	Horizontal	Pass
		846.5	6.30	2.02	19.79	2.15	21.92	155.597	Horizontal	Pass
10.0MHz Band QPSK	1/#Mid	829	6.60	2.01	19.73	2.15	<b>22.17</b>	164.816	Horizontal	Pass
		836.5	6.55	2.01	19.77	2.15	22.16	164.437	Horizontal	Pass
		844	6.45	2.02	19.78	2.15	22.06	160.694	Horizontal	Pass
1.4MHz Band QPSK	1/#Mid	824.7	5.04	2.01	19.68	2.15	20.56	113.763	Vertical	Pass
		836.5	4.75	2.01	19.77	2.15	20.36	108.643	Vertical	Pass
		848.3	5.67	2.02	19.82	2.15	21.32	135.519	Vertical	Pass
3.0MHz Band QPSK	1/#Mid	825.5	5.19	2.01	19.70	2.15	20.73	118.304	Vertical	Pass
		836.5	5.17	2.01	19.77	2.15	20.78	119.674	Vertical	Pass
		847.5	5.55	2.02	19.81	2.15	21.19	131.522	Vertical	Pass
5.0MHz Band QPSK	1/#Mid	826.5	5.64	2.01	19.71	2.15	21.19	131.522	Vertical	Pass
		836.5	5.60	2.01	19.77	2.15	21.21	132.130	Vertical	Pass
		846.5	5.28	2.02	19.79	2.15	20.90	123.027	Vertical	Pass
10.0MHz Band QPSK	1/#Mid	829	5.75	2.01	19.73	2.15	21.32	135.519	Vertical	Pass
		836.5	5.29	2.01	19.77	2.15	20.90	123.027	Vertical	Pass
		844	5.36	2.02	19.78	2.15	20.97	125.026	Vertical	Pass

Radiated Power (ERP) for Band 5											
Mode	RB/RB SIZE	Frequency	Result							Polarization Of Max. ERP	Conclusion
			SG Level	Cable Loss	Antenna Factor	Correction	Max. EIRP	Max. EIRP			
			(dBm)	(dBm)	(dB)	(dB)	Average	Average			
							(dBm)	(mW)			
1.4MHz Band 16 QAM	3/#Mid	824.7	5.68	2.01	19.68	2.15	21.20	131.826	Horizontal	Pass	
		836.5	5.61	2.01	19.77	2.15	21.22	132.434	Horizontal	Pass	
		848.3	5.45	2.02	19.82	2.15	21.10	128.825	Horizontal	Pass	
3.0MHz Band 16 QAM	1/#Mid	825.5	5.76	2.01	19.70	2.15	21.30	134.896	Horizontal	Pass	
		836.5	5.47	2.01	19.77	2.15	21.08	128.233	Horizontal	Pass	
		847.5	4.95	2.02	19.81	2.15	20.59	114.551	Horizontal	Pass	
5.0MHz Band 16 QAM	1/#Mid	826.5	6.08	2.01	19.71	2.15	21.63	145.546	Horizontal	Pass	
		836.5	5.85	2.01	19.77	2.15	21.46	139.959	Horizontal	Pass	
		846.5	5.60	2.02	19.79	2.15	21.22	132.434	Horizontal	Pass	
10.0MHz Band 16 QAM	1/#Mid	829	6.08	2.01	19.73	2.15	<b>21.65</b>	146.218	Horizontal	Pass	
		836.5	5.80	2.01	19.77	2.15	21.41	138.357	Horizontal	Pass	
		844	5.34	2.02	19.78	2.15	20.95	124.451	Horizontal	Pass	
1.4MHz Band 16 QAM	1/#Mid	824.7	4.53	2.01	19.68	2.15	20.05	101.158	Vertical	Pass	
		836.5	4.23	2.01	19.77	2.15	19.84	96.383	Vertical	Pass	
		848.3	4.09	2.02	19.82	2.15	19.74	94.189	Vertical	Pass	
3.0MHz Band 16 QAM	1/#Mid	825.5	4.50	2.01	19.70	2.15	20.04	100.925	Vertical	Pass	
		836.5	5.08	2.01	19.77	2.15	20.69	117.220	Vertical	Pass	
		847.5	3.74	2.02	19.81	2.15	19.38	86.696	Vertical	Pass	
5.0MHz Band 16 QAM	1/#Mid	826.5	4.84	2.01	19.71	2.15	20.39	109.396	Vertical	Pass	
		836.5	4.33	2.01	19.77	2.15	19.94	98.628	Vertical	Pass	
		846.5	5.42	2.02	19.79	2.15	21.04	127.057	Vertical	Pass	
10.0MHz Band 16 QAM	1/#Mid	829	5.68	2.01	19.73	2.15	21.25	133.352	Vertical	Pass	
		836.5	5.62	2.01	19.77	2.15	21.23	132.739	Vertical	Pass	
		844	5.11	2.02	19.78	2.15	20.72	118.032	Vertical	Pass	

Note:

ERP=EIRP-2.15

SG Level= Signal generator output

Max. EIRP Average (dBm)= Antenna Factor (dB)+ SG Level (dBm)- Cable Loss(dBm)

## 9. SPURIOUS RADIATION EMISSION

### RULE PART(S)

FCC: §2.1051, §22.917(a), §24.238(a), §27.53(c)(g)(h)(m)

### LIMIT

For Band 7, the minimum permissible attenuation level of any spurious emission is  $55 + \log_{10}(P)$  [Watts].

The minimum permissible attenuation level of any spurious emission is  $43 + \log_{10}(P)$  [Watts], where P is the transmitter power in Watts.

### TEST PROCEDURE

For Cellular equipment - Compliance with these rules is based on the use of measurement instrumentation employing a resolution bandwidth of 100 kHz or greater. In the 1 MHz bands immediately outside and adjacent to the frequency block a resolution bandwidth of at least one percent of the emission bandwidth of the fundamental emission of the transmitter may be employed. A narrower resolution bandwidth is permitted in all cases to improve measurement accuracy provided the measured power is integrated over the full required measurement bandwidth (i.e. 100 kHz or 1 percent of emission bandwidth, as specified). The emission bandwidth is defined as the width of the signal between two points, one below the carrier center frequency and one above the carrier center frequency, outside of which all emissions are attenuated at least 26 dB below the transmitter power.

For PCS equipment - Compliance with these rules is based on the use of measurement instrumentation employing a resolution bandwidth of 1 MHz or greater. However, in the 1 MHz bands immediately outside and adjacent to the frequency block a resolution bandwidth of at least one percent of the emission bandwidth of the fundamental emission of the transmitter may be employed. A narrower resolution bandwidth is permitted in all cases to improve measurement accuracy provided the measured power is integrated over the full required measurement bandwidth (i.e. 1 MHz or 1 percent of emission bandwidth, as specified). The emission bandwidth is defined as the width of the signal between two points, one below the carrier center frequency and one above the carrier center frequency, outside of which all emissions are attenuated at least 26 dB below the transmitter power.

The unwanted emission power shall be measured with a resolution bandwidth of at least 1% of the occupied bandwidth in the 1 MHz band immediately outside and adjacent to the channel edge of the equipment. Beyond the 1 MHz band immediately outside the channel edge of the equipment, a resolution bandwidth of 1 MHz shall be employed. A narrower resolution bandwidth is allowed to be used provided that the measured power is integrated over the full required measurement bandwidth of 1 MHz or 1% of the occupied bandwidth as applicable.

The power of any unwanted emissions measured from the channel edge of the equipment shall be attenuated below the transmitter power, P (dBW), as follows:

- a. for base station and subscriber equipment, other than mobile subscriber equipment, the attenuation shall not be less than  $43 + 10 \text{ Log}_{10} (p)$ , dB; and
- b. for mobile subscriber equipment, the attenuation shall not be less than  $43 + 10 \text{ Log}_{10} (p)$ , dB at the channel edges and  $55 + 10 \text{ Log}_{10} (p)$  at 5.5 MHz away and beyond the channel edges where p in (a) and (b) is the transmitter power measured in watts.

**MODES TESTED**

- LTE Band2  
LTE Band 4
- LTE Band 5

**RESULTS**

PASS

9.1 LTE BAND 2

**QPSK EIRP POWER FOR LTE BAND 2 (1.4MHZ BANDWIDTH)**

Test Results for Low Channel 1850.7MHz							
Frequency(MHz)	SG Level(dBm)	Cable Loss(dB)	Antenna Factor(dB)	Absolute Level(dBm)	Limit (dBm)	Margin(dBm)	Polarity
3701.4	-44.30	4.04	33.51	-14.83	-13	-1.83	Horizontal
3701.4	-52.24	4.04	33.51	-22.77	-13	-9.77	Vertical
5552.1	-48.92	5.24	35.84	-18.32	-13	-5.32	Vertical
5552.1	-52.67	5.24	35.84	-22.07	-13	-9.07	Horizontal
184.4	-42.60	1.43	16.02	-28.01	-13	-15.01	Vertical
276.5	-39.13	1.30	17.99	-22.44	-13	-9.44	Horizontal
Test Results for Mid Channel 1880MHz							
3760.0	-48.15	4.04	33.56	-18.63	-13	-5.63	Horizontal
3760.0	-47.42	4.04	33.56	-17.90	-13	-4.90	Vertical
5640.0	-52.85	5.24	35.91	-22.18	-13	-9.18	Vertical
5640.0	-49.69	5.24	35.91	-19.02	-13	-6.02	Horizontal
211.9	-42.06	1.62	16.97	-26.71	-13	-13.71	Vertical
342.5	-37.93	1.74	15.98	-23.70	-13	-10.70	Horizontal
Test Results for High Channel 1909.3MHz							
3818.6	-46.03	4.04	34.00	-16.07	-13	-3.07	Horizontal
3818.6	-45.02	4.04	34.00	-15.06	-13	-2.06	Vertical
5727.9	-50.37	5.24	36.04	-19.57	-13	-6.57	Vertical
5727.9	-50.27	5.24	36.04	-19.47	-13	-6.47	Horizontal
183.1	-37.99	1.42	17.29	-22.12	-13	-9.12	Vertical
414.5	-43.39	1.50	17.90	-26.98	-13	-13.98	Horizontal



**QPSK EIRP POWER FOR LTE BAND 2 (20.0MHZ BANDWIDTH)**

Test Results for Low Channel 1860MHz							
Frequency(MHz)	SG Level(dBm)	Cable Loss(dB)	Antenna Factor(dB)	Absolute Level(dBm)	Limit (dBm)	Margin(dBm)	Polarity
3720.0	-48.84	4.07	33.54	-19.37	-13	-6.37	Horizontal
3720.0	-44.46	4.07	33.54	-14.99	-13	-1.99	Vertical
5580.0	-49.19	5.28	35.86	-18.61	-13	-5.61	Vertical
5580.0	-49.06	5.28	35.86	-18.48	-13	-5.48	Horizontal
184.5	-41.50	1.58	16.89	-26.18	-13	-13.18	Vertical
453.3	-41.78	1.76	17.26	-26.28	-13	-13.28	Horizontal
Test Results for Mid Channel 1880MHz							
3760.0	-44.67	4.04	33.56	-15.15	-13	-2.15	Horizontal
3760.0	-50.85	4.04	33.56	-21.33	-13	-8.33	Vertical
5640.0	-51.52	5.24	35.91	-20.85	-13	-7.85	Vertical
5640.0	-52.05	5.24	35.91	-21.38	-13	-8.38	Horizontal
179.7	-37.11	1.46	16.27	-22.30	-13	-9.30	Vertical
307.1	-37.61	1.59	15.15	-24.05	-13	-11.05	Horizontal
Test Results for High Channel 1900MHz							
3800.0	-53.52	4.04	34.00	-23.56	-13	-10.56	Horizontal
3800.0	-49.13	4.04	34.00	-19.17	-13	-6.17	Vertical
5700.0	-53.53	5.24	36.04	-22.73	-13	-9.73	Vertical
5700.0	-53.63	5.24	36.04	-22.83	-13	-9.83	Horizontal
184.5	-41.92	1.36	17.39	-25.88	-13	-12.88	Vertical
417.0	-34.88	1.66	15.39	-21.15	-13	-8.15	Horizontal

Note: Spurious Emission Level = Spectrum Analyzer Read Value + Cable Loss+ Antenna Factor + 11.74  
 . Margin = Spurious Emission Level - Limit  
 . Both QPSK and 16QAM has been tested, the worst case is QPSK mode, the report just reported the worst case.

## 9.2 LTE BAND 4

### QPSK EIRP POWER FOR LTE BAND 4 (1.4MHZ BANDWIDTH)

Test Results for Low Channel 1710.7MHz							
Frequency(MHz)	SG Level(dBm)	Cable Loss(dB)	Antenna Factor(dB)	Absolute Level(dBm)	Limit (dBm)	Margin(dBm)	Polarity
3421.4	-51.96	4.02	29.80	-26.18	-13	-13.18	Horizontal
3421.4	-46.41	4.02	29.80	-20.63	-13	-7.63	Vertical
5132.1	-51.95	5.24	35.84	-21.35	-13	-8.35	Vertical
5132.1	-52.35	5.24	35.84	-21.75	-13	-8.75	Horizontal
185.9	-43.07	1.68	16.04	-28.71	-13	-15.71	Vertical
278.3	-42.89	1.78	17.74	-26.93	-13	-13.93	Horizontal
Test Results for Mid Channel 1732.5MHz							
3465.0	-48.85	4.03	30.00	-22.88	-13	-9.88	Horizontal
3465.0	-47.28	4.03	30.00	-21.31	-13	-8.31	Vertical
5197.5	-45.93	5.25	35.86	-15.32	-13	-2.32	Vertical
5197.5	-53.63	5.25	35.86	-23.02	-13	-10.02	Horizontal
196.8	-34.51	1.72	17.69	-18.54	-13	-5.54	Vertical
350.9	-34.66	1.62	16.02	-20.25	-13	-7.25	Horizontal
Test Results for High Channel 1754.3MHz							
3508.6	-52.74	4.05	30.01	-26.78	-13	-13.78	Horizontal
3508.6	-47.10	4.05	30.01	-21.14	-13	-8.14	Vertical
5262.9	-47.46	5.26	35.86	-16.86	-13	-3.86	Vertical
5262.9	-52.27	5.26	35.86	-21.67	-13	-8.67	Horizontal
200.7	-36.79	1.80	16.69	-21.90	-13	-8.90	Vertical
459.2	-42.86	1.75	16.66	-27.96	-13	-14.96	Horizontal

**QPSK EIRP POWER FOR LTE BAND 4 (20.0MHZ BANDWIDTH)**

Test Results for Low Channel 1720MHz							
Frequency(MHz)	SG Level(dBm)	Cable Loss(dB)	Antenna Factor(dB)	Absolute Level(dBm)	Limit (dBm)	Margin(dBm)	Polarity
3440.0	-52.75	4.02	29.80	-26.97	-13	-13.97	Horizontal
3440.0	-53.19	4.02	29.80	-27.41	-13	-14.41	Vertical
5160.0	-45.92	5.24	35.84	-15.32	-13	-2.32	Vertical
5160.0	-52.44	5.24	35.84	-21.84	-13	-8.84	Horizontal
194.1	-38.26	1.57	17.26	-22.57	-13	-9.57	Vertical
372.8	-43.50	1.78	16.35	-28.93	-13	-15.93	Horizontal
Test Results for Mid Channel 1732.5MHz							
3465.0	-48.82	4.03	30.00	-22.85	-13	-9.85	Horizontal
3465.0	-51.39	4.03	30.00	-25.42	-13	-12.42	Vertical
5197.5	-46.31	5.25	35.86	-15.70	-13	-2.70	Vertical
5197.5	-53.66	5.25	35.86	-23.05	-13	-10.05	Horizontal
189.6	-38.57	1.44	17.95	-22.06	-13	-9.06	Vertical
333.0	-38.59	1.65	16.09	-24.15	-13	-11.15	Horizontal
Test Results for High Channel 1745MHz							
3490.0	-48.84	2.91	27.68	-24.07	-13	-11.07	Horizontal
3490.0	-53.25	2.91	27.68	-28.48	-13	-15.48	Vertical
5235.0	-43.58	5.26	35.86	-16.98	-13	-3.98	Vertical
5235.0	-53.27	5.26	35.86	-22.67	-13	-9.67	Horizontal
185.5	-42.74	1.61	16.85	-27.50	-13	-14.50	Vertical
318.0	-36.04	1.61	15.19	-22.46	-13	-9.46	Horizontal

Note: Spurious Emission Level = Spectrum Analyzer Read Value + Cable Loss+ Antenna Factor + 11.74

. Margin = Spurious Emission Level - Limit

. Both QPSK and 16QAM has been tested, the worst case is QPSK mode, the report just reported the worst case.

**9.3 LTE BAND 5**  
**QPSK EIRP POWER FOR LTE BAND 5 (1.4MHZ BANDWIDTH)**

Test Results for Low Channel 824.7MHz							
Frequency(MHz)	SG Level(dBm)	Cable Loss(dB)	Antenna Factor(dB)	Absolute Level(dBm)	Limit (dBm)	Margin(dBm)	Polarity
1649.4	-52.02	2.78	27.50	-27.30	-13	-14.30	Horizontal
1649.4	-46.54	2.78	27.50	-21.82	-13	-8.82	Vertical
2474.1	-50.60	2.90	27.80	-25.70	-13	-12.70	Vertical
2474.1	-53.45	2.90	27.80	-28.55	-13	-15.55	Horizontal
188.8	-39.33	1.76	17.59	-23.50	-13	-10.50	Vertical
375.6	-42.64	1.63	15.87	-28.40	-13	-15.40	Horizontal
Test Results For Mid Channel 836.5MHz							
1673.0	-45.13	2.80	27.48	-20.45	-13	-7.45	Horizontal
1673.0	-48.10	2.80	27.48	-23.42	-13	-10.42	Vertical
2509.5	-47.15	2.91	27.70	-22.36	-13	-9.36	Vertical
2509.5	-51.54	2.91	27.70	-26.75	-13	-13.75	Horizontal
207.7	-34.81	1.61	15.68	-20.74	-13	-7.74	Vertical
368.5	-34.92	1.59	17.52	-19.00	-13	-6.00	Horizontal
Test Results for High Channel 848.3MHz							
1696.6	-49.15	2.82	27.43	-24.54	-13	-11.54	Horizontal
1696.6	-45.81	2.82	27.43	-21.20	-13	-8.20	Vertical
2544.9	-44.09	2.92	27.74	-19.27	-13	-6.27	Vertical
2544.9	-51.39	2.92	27.74	-26.57	-13	-13.57	Horizontal
212.9	-35.75	1.69	16.67	-20.76	-13	-7.76	Vertical
292.0	-44.13	1.70	17.18	-28.65	-13	-15.65	Horizontal

**QPSK EIRP POWER FOR LTE BAND 5 (10MHZ BANDWIDTH)**

Test Results for Low Channel 829MHz							
Frequency(MHz)	SG Level(dBm)	Cable Loss(dB)	Antenna Factor(dB)	Absolute Level(dBm)	Limit (dBm)	Margin(dBm)	Polarity
1658.0	-52.37	2.78	27.50	-27.65	-13	-14.65	Horizontal
1658.0	-45.39	2.78	27.50	-20.67	-13	-7.67	Vertical
2487.0	-51.69	2.90	27.80	-26.79	-13	-13.79	Vertical
2487.0	-53.52	2.90	27.80	-28.62	-13	-15.62	Horizontal
201.7	-39.83	1.71	15.57	-25.97	-13	-12.97	Vertical
287.5	-37.41	1.34	16.40	-22.35	-13	-9.35	Horizontal
Test Results for Mid Channel 836.5MHz							
1673.0	-50.13	2.80	27.48	-25.45	-13	-12.45	Horizontal
1673.0	-48.99	2.80	27.48	-24.31	-13	-11.31	Vertical
2509.5	-45.36	2.91	27.70	-20.57	-13	-7.57	Vertical
2509.5	-49.94	2.91	27.70	-25.15	-13	-12.15	Horizontal
202.9	-34.80	1.44	17.04	-19.20	-13	-6.20	Vertical
469.1	-42.54	1.76	17.62	-26.68	-13	-13.68	Horizontal
Test Results for High Channel 844MHz							
1688.0	-49.49	2.82	27.43	-24.88	-13	-11.88	Horizontal
1688.0	-51.95	2.82	27.43	-27.34	-13	-14.34	Vertical
2532.0	-46.63	2.92	27.74	-21.81	-13	-8.81	Vertical
2532.0	-51.40	2.92	27.74	-26.58	-13	-13.58	Horizontal
204.4	-38.50	1.74	17.70	-22.54	-13	-9.54	Vertical
288.9	-40.15	1.41	17.46	-24.09	-13	-11.09	Horizontal

Note: Spurious Emission Level = Spectrum Analyzer Read Value + Cable Loss+ Antenna Factor + 11.74

. Margin = Spurious Emission Level - Limit

. Both QPSK and 16QAM has been tested, the worst case is QPSK mode, the report just reported the worst case.

## 10. FREQUENCY STABILITY

### RULE PART(S)

FCC: §2.1055, §22.355, §24.235, §27.54

### LIMITS

§22.355 - The carrier frequency shall not depart from the reference frequency in excess of  $\pm 2.5$  ppm for mobile stations.

§24.235 - The frequency stability shall be sufficient to ensure that the fundamental emission stays within the authorized frequency block.

### TEST PROCEDURE

Use CMW 500 with Frequency Error measurement capability.

- Temp. =  $-30^{\circ}$  to  $+50^{\circ}\text{C}$
- Voltage = low voltage, DC 34V, Normal, DC 3.7V and High voltage, DC 4.2V.

### Frequency Stability vs Temperature:

The EUT is placed inside a temperature chamber. The temperature is set to  $-30^{\circ}\text{C}$  and allowed to stabilize. After sufficient soak time, the transmitting frequency error is measured. The temperature is increased by 10 degrees, allowed to stabilize and soak, and then the measurement is repeated. This is repeated until  $+50^{\circ}\text{C}$  is reached.

### Frequency Stability vs Voltage:

The peak frequency error is recorded (worst-case).

### MODES TESTED

- LTE Band2  
LTE Band 4
- LTE Band5

## RESULTS

See the following pages.

10.1 LTE BAND 2

**Band 2 QPSK, (20MHz BANDWIDTH RB size 100 RB Offset 0)**

**Frequency error vs. Voltage**

Voltage [Vdc]	Frequency [MHz]	Frequency* Error[Hz]	Frequency Error[ppm]	Limit [ppm]
3.4	1880	12.7	0.006773	2.5
3.7	1880	13.4	0.007152	2.5
4.2	1880	13.3	0.007074	2.5

**Frequency error vs. Temperature**

Temperature [° C]	Frequency [MHz]	Frequency* Error[Hz]	Frequency Error[ppm]	Limit [ppm]
Normal (25C)	1880	12.2	0.006502	2.5
Extreme (50C)	1880	11.6	0.006157	2.5
Extreme (40C)	1880	13.7	0.007308	2.5
Extreme (30C)	1880	13.1	0.006973	2.5
Extreme (10C)	1880	13.9	0.007418	2.5
Extreme (0C)	1880	11.7	0.006237	2.5
Extreme (-10C)	1880	13.2	0.007026	2.5
Extreme (-20C)	1880	13.7	0.007270	2.5
Extreme (-30C)	1880	15.1	0.008026	2.5

**Band 2 16QAM, (20MHz BANDWIDTH RB size 100 RB Offset 0)**

**Frequency error vs. Voltage**

Voltage [Vdc]	Frequency [MHz]	Frequency* Error[Hz]	Frequency Error[ppm]	Limit [ppm]
3.4	1880	9.7	0.005138	2.5
3.7	1880	8.8	0.004676	2.5
4.2	1880	8.5	0.004542	2.5

**Frequency error vs. Temperature**

Temperature [° C]	Frequency [MHz]	Frequency* Error[Hz]	Frequency Error[ppm]	Limit [ppm]
Normal (25C)	1880	9.5	0.005067	2.5
Extreme (50C)	1880	8.8	0.004701	2.5
Extreme (40C)	1880	8.1	0.004291	2.5
Extreme (30C)	1880	9.2	0.004885	2.5
Extreme (10C)	1880	8.6	0.004572	2.5
Extreme (0C)	1880	8.1	0.004316	2.5
Extreme (-10C)	1880	9.5	0.005040	2.5
Extreme (-20C)	1880	8.8	0.004681	2.5
Extreme (-30C)	1880	8.4	0.004455	2.5

\*Note: Frequency error measurements were made by using the build-in capability of the Wireless Communication Test Set.



10.2 LTE BAND 4

**Band 4 QPSK, (20MHz BANDWIDTH RB size 100 RB Offset 0)**

**Frequency error vs. Voltage**

Voltage [Vdc]	Frequency [MHz]	Frequency* Error[Hz]	Frequency Error[ppm]	Limit [ppm]
3.4	1732.5	8.7	0.005026	2.5
3.7	1732.5	8.8	0.005057	2.5
4.2	1732.5	8.6	0.004979	2.5

**Frequency error vs. Temperature**

Temperature [°C]	Frequency [MHz]	Frequency* Error[Hz]	Frequency Error[ppm]	Limit [ppm]
Normal (25C)	1732.5	8.6	0.004985	2.5
Extreme (50C)	1732.5	9.4	0.005403	2.5
Extreme (40C)	1732.5	7.0	0.004023	2.5
Extreme (30C)	1732.5	6.0	0.003458	2.5
Extreme (10C)	1732.5	7.2	0.004162	2.5
Extreme (0C)	1732.5	9.2	0.005311	2.5
Extreme (-10C)	1732.5	8.8	0.005057	2.5
Extreme (-20C)	1732.5	6.4	0.003717	2.5
Extreme (-30C)	1732.5	7.9	0.004561	2.5

**Band 4 16QAM, (20MHz BANDWIDTH RB size 100 RB Offset 0)**

**Frequency error vs. Voltage**

Voltage [Vdc]	Frequency [MHz]	Frequency* Error[Hz]	Frequency Error[ppm]	Limit [ppm]
3.4	1732.5	9.3	0.005373	2.5
3.7	1732.5	9.3	0.005389	2.5
4.2	1732.5	7.8	0.004520	2.5

**Frequency error vs. Temperature**

Temperature [°C]	Frequency [MHz]	Frequency* Error[Hz]	Frequency Error[ppm]	Limit [ppm]
Normal (25C)	1732.5	9.8	0.005678	2.5
Extreme (50C)	1732.5	8.5	0.004914	2.5
Extreme (40C)	1732.5	8.1	0.004654	2.5
Extreme (30C)	1732.5	9.1	0.005224	2.5
Extreme (10C)	1732.5	9.3	0.005369	2.5
Extreme (0C)	1732.5	8.5	0.004911	2.5
Extreme (-10C)	1732.5	8.9	0.005165	2.5
Extreme (-20C)	1732.5	9.0	0.005177	2.5
Extreme (-30C)	1732.5	8.5	0.004884	2.5

**\*Note:** Frequency error measurements were made by using the build-in capability of the Wireless Communication Test Set.

10.3 LTE BAND 5

**Band 5 QPSK, (10MHz BANDWIDTH RB size 50 RB Offset 0)**

**Frequency error vs. Voltage**

Voltage [Vdc]	Frequency [MHz]	Frequency* Error[Hz]	Frequency Error[ppm]	Limit [ppm]
3.4	836.5	5.5	0.006600	2.5
3.7	836.5	7.1	0.008539	2.5
4.2	836.5	4.4	0.005291	2.5

**Frequency error vs. Temperature**

Temperature [° C]	Frequency [MHz]	Frequency* Error[Hz]	Frequency Error[ppm]	Limit [ppm]
Normal (25C)	836.5	5.8	0.006917	2.5
Extreme (50C)	836.5	5.9	0.007006	2.5
Extreme (40C)	836.5	6.3	0.007536	2.5
Extreme (30C)	836.5	6.4	0.007627	2.5
Extreme (10C)	836.5	5.7	0.006797	2.5
Extreme (0C)	836.5	4.8	0.005769	2.5
Extreme (-10C)	836.5	5.6	0.006647	2.5
Extreme (-20C)	836.5	6.5	0.007804	2.5
Extreme (-30C)	836.5	6.3	0.007577	2.5

**Band 5 16QAM, (10MHz BANDWIDTH RB size 50 RB Offset 0)**

**Frequency error vs. Voltage**

Voltage [Vdc]	Frequency [MHz]	Frequency* Error[Hz]	Frequency Error[ppm]	Limit [ppm]
3.4	836.5	5.7	0.006761	2.5
3.7	836.5	6.6	0.007937	2.5
4.2	836.5	5.2	0.006159	2.5

**Frequency error vs. Temperature**

Temperature [° C]	Frequency [MHz]	Frequency* Error[Hz]	Frequency Error[ppm]	Limit [ppm]
Normal (25C)	836.5	6.6	0.007858	2.5
Extreme (50C)	836.5	6.0	0.007188	2.5
Extreme (40C)	836.5	6.3	0.007555	2.5
Extreme (30C)	836.5	6.6	0.007899	2.5
Extreme (10C)	836.5	5.7	0.006851	2.5
Extreme (0C)	836.5	5.4	0.006436	2.5
Extreme (-10C)	836.5	5.5	0.006544	2.5
Extreme (-20C)	836.5	6.3	0.007563	2.5
Extreme (-30C)	836.5	5.8	0.006983	2.5

**\*Note:** Frequency error measurements were made by using the build-in capability of the Wireless Communication Test Set.

## 11. Peak-to-Average Ratio

### 11.1 Description of the PAR Measurement

The peak-to-average ratio (PAR) of the transmission may not exceed 13 dB.

### 11.2 Measuring Instruments

See list of measuring instruments of this test report.

### 11.3 Test Procedures

1. The EUT was connected to Spectrum Analyzer and Base Station via power divider.
2. The RF output of EUT was connected to the spectrum analyzer by RF cable and attenuator. The path loss was compensated to the results for each measurement.
3. For LTE operating modes:
  - a. Set the CCDF (Complementary Cumulative Distribution Function) option in spectrum analyzer.
  - b. The highest RF powers were measured and recorded the maximum PAPR level associated with a probability of 0.1 %.

### 11.4 Test Setup

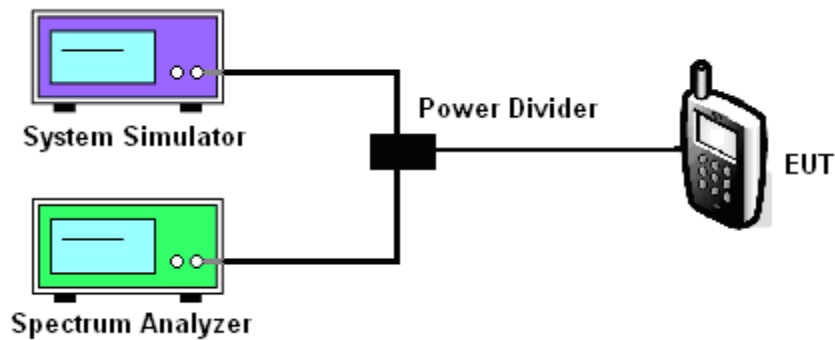

### MODES TESTED

- LTE Band 2/4/5
- 

Test data reference attachment.

----END OF REPORT----