

SPECIFICATION SHEET



CUSTOMER: Zhongli Guanda (shenzhen) Intelligent Technology CO., Ltd

DESCRIPTION: QT14-Apple Watch Coil(length of lead :31mm)

CUSTOMER P/N: _____

PART NUMBER: _____

DATE: 2022-10-30

ACCEPTANCE STAMP



PREPARED BY	ENGINEER CHECKED BY	PRODUCTION CHECKED BY	APPROVED BY
Feng Xin	Chen zi qi	Huang Qiong	Chen Jun

History For Revised Specification	CUSTOMER P/N :	
	PART NUMBER :	

Rev.	DESCRIPTION (Content Or Reason For Changed)	Date	Revisor
A.0	The first Release version	2022/10/30	Chen Jun

PREPARED BY	ENGINEER CHECKED BY	PRODUCTION CHECKED BY	APPROVED BY
Feng Xin	Chao zi qi	Huang Qiong	Chen Jun

ADDRESS: 3rd Floor, No. 181, Mingyue 2nd Road, Shiwang Town, Boluo County, Huizhou city

TEL: 0752-6668681

E-MAIL: 839689578@qq.com

Specification	CUSTOMER P/N :	
	PART NUMBER :	

1. DIMENSIONS: (Unit: mm)

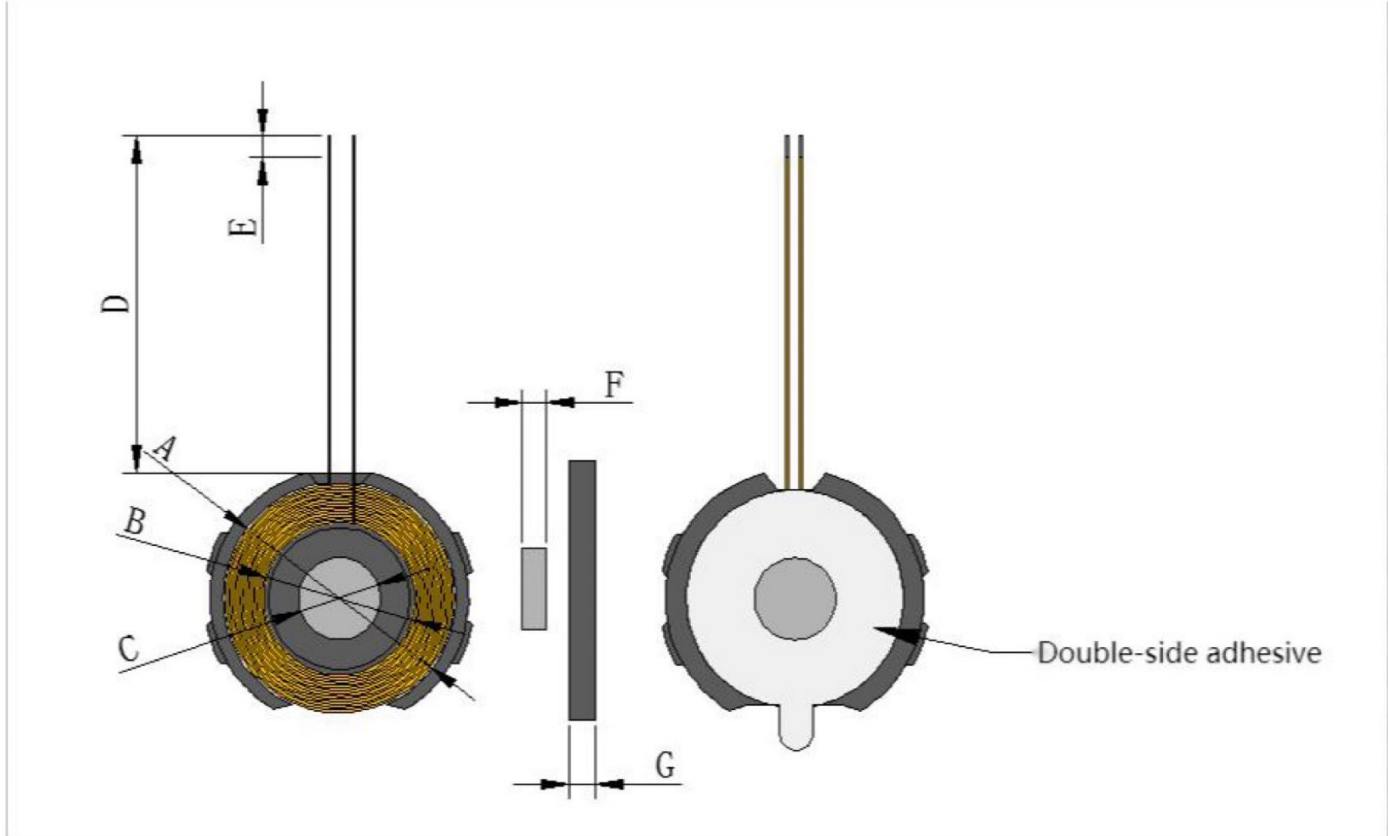

A	B	C	D	E	F			
21max	14±0.5	7.5±0.5	31±1	2.2±0.5	2.8max			

1.Magnet specifications : ϕ 7.5mm*2.2mm

2.Magnetic magnet: 2900GS-3200GS

PREPARED BY	ENGINEER CHECKED BY	PRODUCTION CHECKED BY	APPROVED BY
Feng Xin	Chao zi qi	Huang Qiong	Chen Jun

ADDRESS: 3rd Floor, No. 181, Mingyue 2nd Road, Shiwang Town, Boluo County, Huizhou city

TEL: 0752-6668681

E-MAIL: 839689578@qq.com

2. WINDING DETAILS

Turns	Wire Dia	Wdg. Type (Spred/Close)	Wdg.Direction	Intersect (Yes/No)
14 TS	0.08*24P(Hot air self-adhesive wire)	Close	Anticlockwise	Yes

3. ELECTRICAL CHARACTERISTICS

- TEMPERATURE:25±10℃
- RELATIVE HUMIDITY:65±10%

NO.	ITEM	TERMINAL	SPECIFICATION	TEST FREQUENCY	TEST EQUIPMENTS
1.	IND	S-F	8.1μh±0.3	100kHz/V	UC2906A
2.	Q	S-F	25Min	100kHz/V	UC2906A
3.	DCR	S-F	135mΩMax	100kHz/V	UC2906A

PREPARED BY	ENGINEER CHECKED BY	PRODUCTION CHECKDED BY	APPROVED BY
Feng Xin	Chao zi qi	Huang Qiong	Chen Jun

ADDRESS: 3rd Floor, No. 181, Mingyue 2nd Road, Shiwang Town, Boluo County, Huizhou city

TEL: 0752-6668681

E-MAIL: 839689578@qq.com

SPECIFICATION APPROVAL

产品型号: D E S T:	Ø13.8*0.07*100P*12TS- 6.4UH-12MM	版 本: VERSION:	V0	客户:	
				客户料 号:	
				Y-5441	

一、尺寸 DIMENSION: (mm)

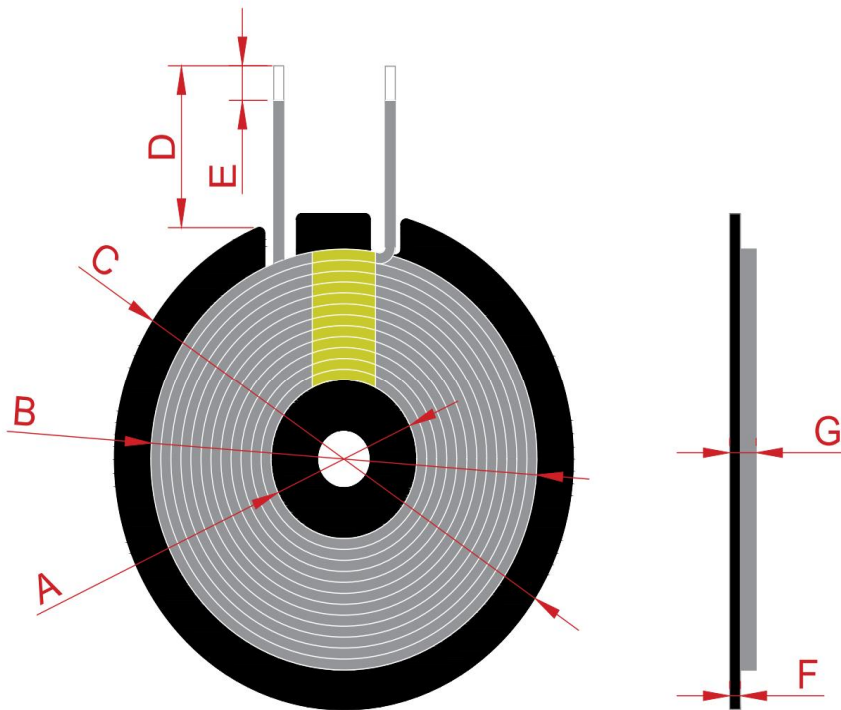

A	13.8±0.5
B	35.5±0.5
C	43.5±0.5
D	12±1
E	3±1
F	1±0.05
G	2.5 MAX
H	
I	
J	
K	
L	

备注： 线圈终止线处缠6MM高温胶带，磁片背面贴双面胶

制定/日期 PREPARED BY/DATE	审核/日期 CHECKED BY/DATE
郑少东/2022.07.15	姚振东/2022.07.15

SPECIFICATION APPROVAL

产品型号: D E S T:	Ø13.8*0.07*100P*12TS- 6.4UH-12MM	版 本: VERSION:	V0	客 户:	
				客 户 料 号:	

五、产品实物图 PRODUCT PICTURE

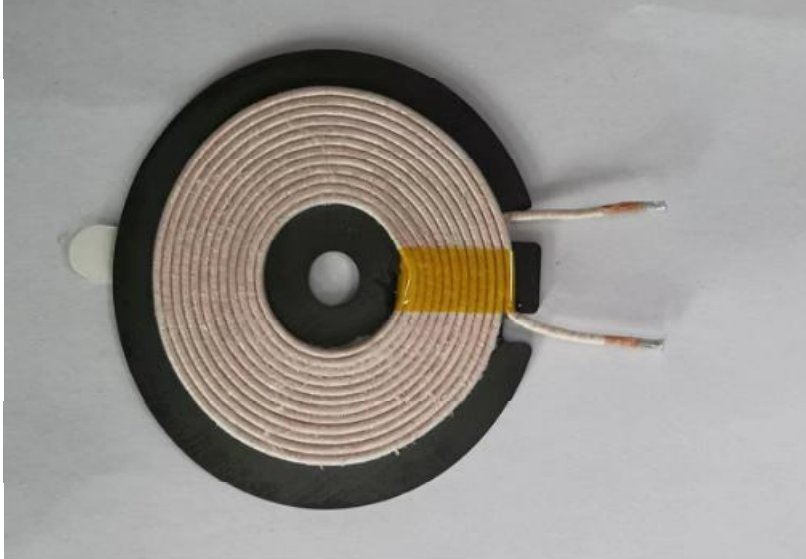

六、材料清单 MATERIAL LIST

序号 NO	材料名称 MATERIAL NAME	品名描述 DESCRIPTION	制造商 MANUFACTURER
1	线 材	0.07*100P	RH
2	磁 片	Ø43.8*5.3*1.0mm铁氧体磁片	KHF
3	锡 条	高温环保锡	DB
4	胶 水	BE885-9007	BR
5	胶 带	6mm高温胶带	
6	背 胶	双面胶	
7	包 装	夹链袋	

备注: REMARK: 以上物料符合ROHS 2.0+REACH环保要求

制定/日期 PREPARED BY/DATE	审核/日期 CHECKED BY/DATE
郑少东/2022.07.15	姚振东/2022.07.15



广东金晟智能有限公司
Guangdong Jinsheng intelligent Co., Ltd

结构尺寸

1. 外形尺寸：（单位：mm）

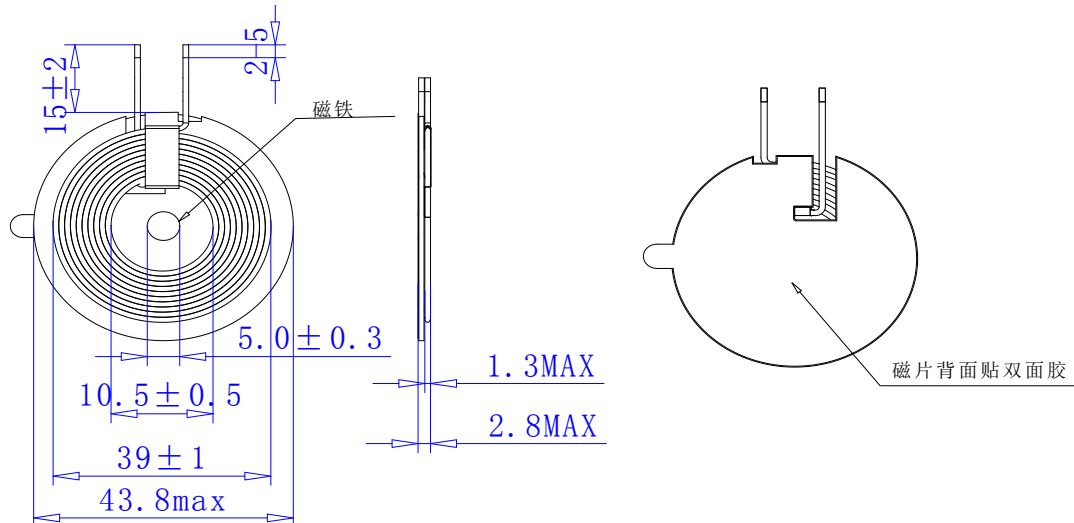

2. 电气性能 (L)：

项目	标准	测式条件	测试仪器	备注
电感1	$6.5\mu\text{H} \pm 10\%$	100KHZ,1V	TH2817B+	带磁片测式
电感	$3.6 \pm 5\%$	100KHZ,1V	TH2817B+	线圈测式
电阻				
Q值				

3. 外观要求：

- 1) 产品形状尺寸要严格控制。
- 2) 产品表面无油污，杂质，毛刺等。
- 3) 不经客户确认，材料不能随意更改
- 4) 产品必须符合ROSH要求

第 3 页	客户代码	版次	编制日期	承制方
		A0	2022. 04. 09	金晟智能



广东金晟智能有限公司
Guangdong Jinsheng intelligent Co., Ltd

材料清单

Bill of materials (材料清单表)

序号 number	材料名称 Material name	品名描述 Description	物料代码 Material Code
1	线材	0.08*105P丝包线	
2	磁片	G44x0.8 双槽带孔	
3	胶布	5MM茶色高温胶带	
4	白胶	工业专用硅酮胶	
5	背胶	G42x0.15h 带手撕位	
6	磁铁	5.0*2.0	

第 4 页	客户代码	版次	编制日期	承制方
		A0	2022.04.09	金晟智能