

SPECIFICATION FOR APPROVAL

1. MECHANICAL DIMENSION (UNIT:mm)

2. SCHEMATICS:

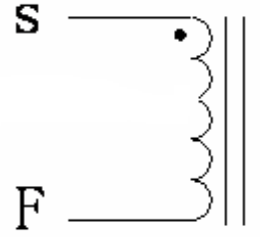
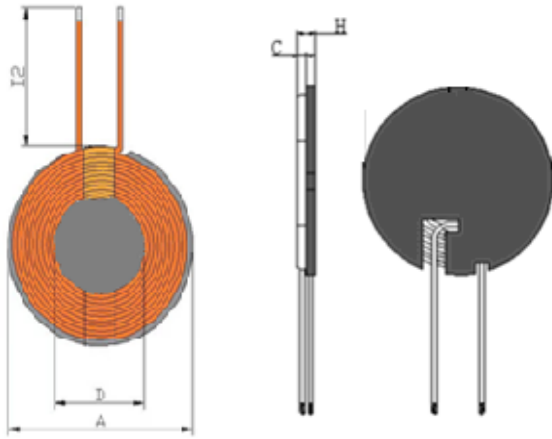

备注: 1. 加18MM小磁片 2. 加背胶

A	D	C	I2	H			
43.5±0.5	19±0.5	0.8±0.05	30±3	2.5Max			

3. WINDING:

STEP	START-FINISH	WIRE TYPE	TURNS	TAPE	REMARK
N1	S-F	热风线 ϕ 0.08*80mm 2UEW	11TS (Ref)		

4. ELECTRICAL SPECIFICATION:

ITEM	L	DCR	温度	HI-POT
TEST	线圈加磁片	S-F	常规状态	
CON	100KHz, 0.25V	AT 25°C		
SPEC	7.4uH±10%	58mΩ Max	80°C	

5. BILF OF MATERIAL:

NO.	ITEM	MATERIAL SPECIFICATION	MANUFACTURER	SGS NO.
1	热风线	热风线0.08*80股	NANJINGJINNINGCO,LTD	
2	无铅锡条	无铅锡条	QIAODO	
3	磁片	43.5*0.8锰锌硬磁片开L槽	TAIYI CO.,LTD	
4	胶水	黄胶9999	LIANCHENG CO.,LTD	
5	高温胶纸	8mm宽高温胶纸	CUDAK CO.,LTD	

HRSW ELECTRONICS CO.,LTD		PART NO	
		TITLE	G43.5开槽+磁吸线圈+小磁片+胶 10MM
DRAWN BY	CHECKED BY		APPROVED BY
何伟华	韦立红		韦立红