

承 認 書

SPECIFICATION FOR APPROVAL

客 戶:

CUSTOMER: _____

客 戶 料 號:

CUST P/N: _____

淘 軟 料 號:

BESOFTP/N: _____

產 品 型 號:

蘋果手表軟磁線圈-CLB
Apple Watch Soft Magnetic
Coil-CLB

DESC:

日 期:

2021/03/10

DATE: _____

版 本:

A.0

Version: _____

擬制 PREPARED BY	審核 CHECKED BY	批准 APPROVED BY	客戶承認 CUSTOMER APPROVE
蘇燕平 Su Yanping	錢立謀 Qian Lizhi	錢立謀 Qian Lizhi	

深圳淘軟電子有限公司

工廠地址：深圳市光明區公明街道李松蓢

第一工業區大園路90-6棟9樓TEL:

13824883512/18038013240

SPECIFICATION

產品型號: DESC	苹果手表软磁线圈-CLB Apple Watch Soft Magnetic Coil-CLB	版本 Rev: A.0	客戶 CUST: 淘软料号 Fine P/N: 客户料号 CUST P/N:	
---------------	--	----------------	--	--

一、尺寸 DIMENSION:(mm)

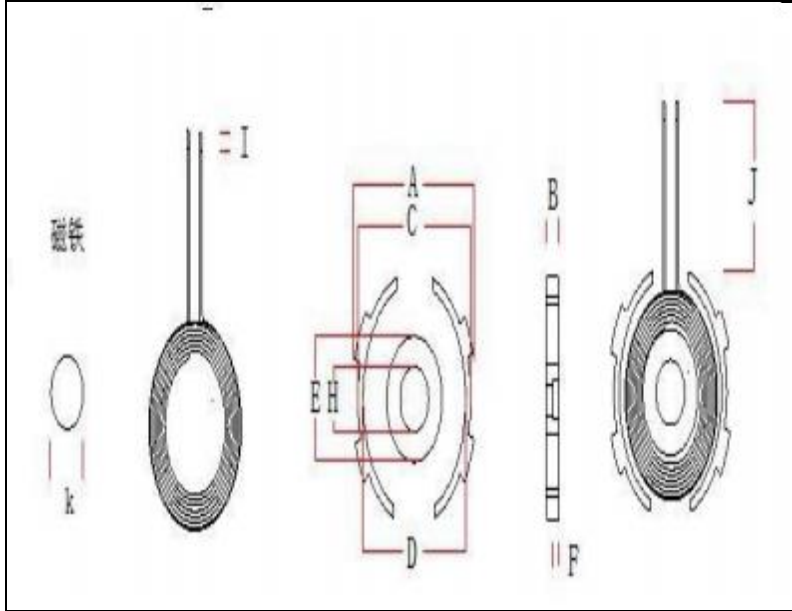

A	24±0.5
B	2.7±0.5
C	23.7±0.25
D	20.5±1
E	13.5±0.3
H	7.5±0.3
I	2±1
J	10±2
K	7.5*2.0

注:

二、原理图 SCHEMATIC DIAGRAM:



三、绕线参数 Winding Specification:

序号 NO.	端子 TERMINAL	线径 WIRE	圈数 Turns	绕线方向 Winding Direction
1	S F	丝包线 0.08*24P silk-covered wire 0.08*24P	12TS	正常 normal

四、电气特性 ELECTRICAL CHARACTERISTICS:

温度 TEMPERATURE: 25 ± 10°C, 湿度 RELATIVE HUMIDITY: 65 ± 20%

序号 NO.	项目 ITEM	端子 TERMINAL	标准 SPECIFICATION	测试条件 TEST FREQUENCY	测试仪器 TEST EQUIPMENTS
1	IND.	S-F	4.3uH ±20% 单独线圈 4.3 uH ± 20% individual coils	100KHz/ 1V	LCZ METER 1062B
2	IND.	S-F	6.2uH ± 10% 加磁片 6.2 uH ± 10% with magnetic chip	100KHz/ 1V	LCZ METER 1062B
3	Q 值	S-F	≥35	100KHz/ 1V	LCZ METER 1062B
4	DCR	S-F			

擬制/日期 PREPARED BY/DATE	審核/日期 CHECKED BY/DATE
------------------------	-----------------------

苏燕平 2020/03/10	钱立谋 2020/03/10
----------------	----------------

注：

- 1.线圈贴磁片，磁片尺寸
24mm,厚度为2.7mm带缺口
- 2.线圈出线位置缠宽度
6mm
±0.5 高温胶纸。
- 3.磁片背面贴带手撕位圆形
直径23mm(ref)
(ref) 普通双面胶。

SPECIFICATION

產品型號: DESC	苹果手表软磁线圈-CLB Apple Watch Soft Magnetic Coil-CLB	版本 Rev: A.0	客戶 CUST: 淘软料号 Fine P/N: 客户料号 CUST P/N:	
---------------	--	----------------	--	--

五、包装 PACKONG:

5.1 包装图片 Packing pictures:

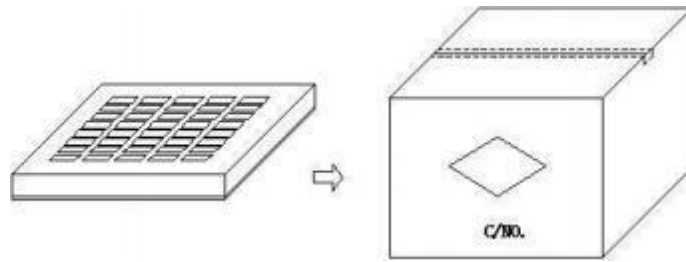

5.2 包装数量及规格 Packing Quantity:

项目 Item	数量 Quantity	材料规格 Material	
盒 Box	3500 Pcs	370*265*55mm	
箱 Big Carton	1400 Pcs	420*270*310mm	

5.3 包装以现有包装盘为参照标准，以实际出货包装为准,如有特要求可以定制。

The packaging shall be based on the existing packing plate and the actual delivery package shall prevail. If there is any requirement, we can customize it.

六、材料清单 Material list:

序号 number	材料名称 Material name	品名描述 Description	制造商 Manufacturer
1	漆包线 0.08*24 股 Enameled wire with 0.08 * 24 strands	热风漆包线 0.08*24 股 Hot air enameled wire 0.08 * 24 strands	
2	无铅锡条 No lead tin strip	无铅锡条 No lead tin strip	
3	磁片 magnetic sheet	Φ24*12.7mm 锰锌硬磁片 Φ24*12.7mm Manganese-zinc hard magnetic sheet	
4	胶水 glue	201 胶水 201 Glue	
5	磁铁 magnet	7.5*2mm	
6	带孔双面胶 Double-sided glue with holes	圆形直径20mm(ref)背胶 Round diameter 20mm (ref) back adhesive	

擬制/日期 PREPARED BY/DATE		審核/日期 CHECKED BY/DATE	
苏燕平 2020/03/10		钱立谋 2020/03/10	