

承 認 書

SPECIFICATION FOR APPROVAL

客 戶：
CUSTOMER: _____
客 戶 料 號：
CUST P/N: _____
淘 軟 料 號：
BESOFTP/N: _____
產 品 型 號：
DESC: Φ 17.2x26.2-9Ts-0.08x105-50mm-
CLB
日 期：
DATE: 2020/08/24
版 本：
Version: A.0

擬 制 PREPARED BY	審 核 CHECKED BY	批 准 APPROVED BY	客 戶 承 認 CUSTOMER APPROVE
苏燕平 Su Yanping	钱立谋 Qian Lizhi	钱立谋 Qian Lizhi	

深圳淘软电子有限公司

工廠地址：深圳市光明区公明街道李松荫

第一工业区大园路90-6栋9楼TEL:

13824883512/18038013240

SPECIFICATION

產品型號: DESC	Φ 17.2x26.2-9Ts-0.08x105-50mm-CLB	版本 Rev: A.0	客戶 CUST: 淘软料号 Fine P/N: 客户料号 CUST P/N:
---------------	-----------------------------------	----------------	--

一、尺寸 DIMENSION:(mm)

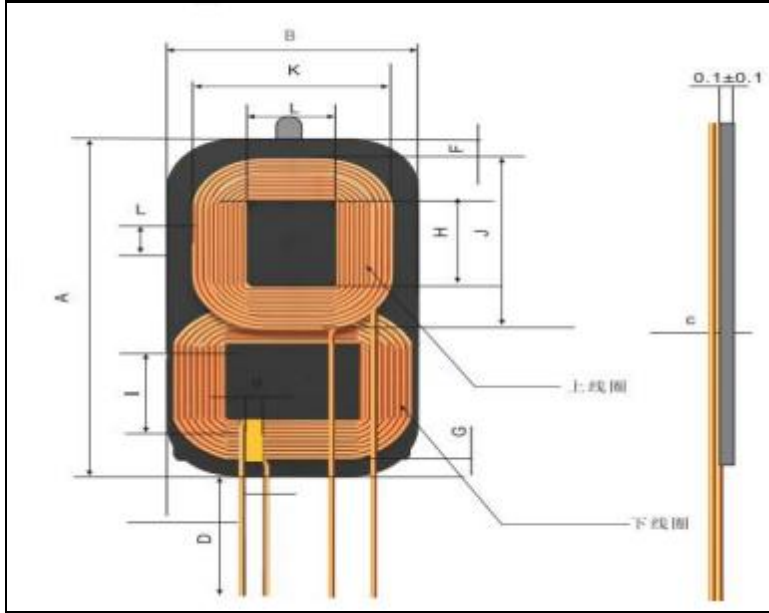

A	83.0±0.5
B	46±0.5
C	3.6±0.2
D	50
J	48
K	38
F	5
G	2
H	26.2
I	17.2

注:

- 1.线圈贴磁片，磁片尺寸 83*46± 1mm, 内孔 5.3mm,厚度为1.0±0.2mm
 - 2.线圈出线位置缠宽度 8mm ±0.5 高温胶纸。
 - 3.磁片背面贴带手撕位圆形直径83*45 普通双面胶。
- pour: 1. The magnetic coil patch, the magnetic chip size is 83 * 46 ± 1mm, the inner hole is 5.3mm, and the thickness is 1.0±0.2mm 2. The winding width of the coil is 8mm ± 0.5 high temperature tape. 3. The back of the magnetic piece with tape hand tear circular diameter 83 * 45 ordinary double-sided tape.

二、原理图 SCHEMATIC DIAGRAM:



三、绕线参数 Winding Specification:

序号 NO.	端子 TERMINAL	线径 WIRE	圈数 Turns	绕线方向 Winding Direction
1	S F	丝包线 0.08*105P silk-covered wire 0.08*105P	9Ts	CCW

四、电气特性 ELECTRICAL CHARACTERISTICS:

温度 TEMPERATURE:25 ± 10°C, 湿度 RELATIVE HUMIDITY:65 ±20%

序号 NO.	项目 ITEM	端子 TERMINAL	标准 SPECIFICATION	测试条件 TEST FREQUENCY	测试仪器 TEST EQUIPMENTS
1	IND.	S-F	3.8uH ±20% 单独线圈 3.8uH ±20% individual coils	100KHz/ 1.0V	LCZ METER 1062B
2	IND.	S-F	6.3uH ± 10% 加磁片 6.3uH ± 10% with magnetic chip	100KHz/ 1.0V	LCZ METER 1062B
3	Q 值	S-F	80.0(ref) 加磁片 80.0(ref) with magnetic chip	100KHz/ 1.0V	LCZ METER 1062B
4	DCR	S-F	≤50mΩ		LCZ METER 502B
拟制/日期 PREPARED BY/DATE			审核/日期 CHECKED BY/DATE		
苏燕平 2020/08/224			钱立谋 2020/08/24		

SPECIFICATION

產品型號: DESC	Φ 17.2x26.2-9Ts-0.08x105-50mm-CLB	版本 Rev: A.0	客戶 CUST: 淘软料号 Fine P/N: 客户料号 CUST P/N:	
---------------	--	----------------	--	--

五、包装 PACKONG:

5.1 包装图片 Packing pictures:

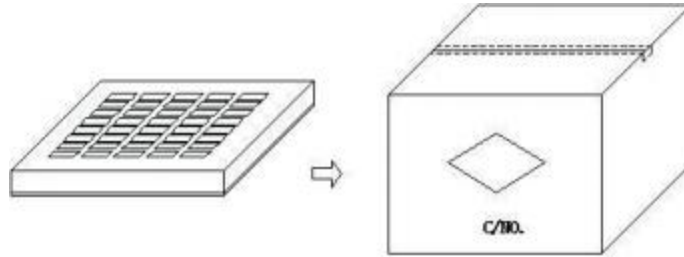

5.2 包装数量及规格 Packing Quantity:

项目 Item	数量 Quantity	材料规格 Material	
盒 Box	600 Pcs	370*265*55mm	
箱 Big Carton	150 Pcs	420*270*310mm	

5.3 包装以现有包装盘为参照标准， 以实际出货包装为准,如有特需要求可以定制。

The packaging shall be based on the existing packing plate and the actual delivery package shall prevail. If there is any requirement, we can customize it.

六、材料清单 Material list:

序号 number	材料名称 Material name	品名描述 Description	制造商 Manufacturer
1	丝包线 0.08*105 股 Enameled wire with 0.08*105	丙酮丝包线 0.08*105 股 0.08*105	
2	无铅锡条 No lead tin strip	无铅锡条 No lead tin strip	
3	磁片 magnetic sheet	Φ 83*46*1.0mm 锰锌硬磁片 Φ 83*46*1.0mm Manganese-zinc hard magnetic sheet	
4	胶水 glue	201 胶水 201 glue	
5	高温胶纸 High temperature rubber paper	8mm 宽高温胶纸 8mm wide high-temperature adhesive tape	
6	带孔双面胶 Double-sided glue with holes	带手撕位圆形直径82*45(ref)背胶 Round diameter 82 * 45 (ref)	

拟制/日期 PREPARED BY/DATE	审核/日期 CHECKED BY/DATE
苏燕平 2020/08/24	钱立谋 2020/08/24