

SPECIFICATION FOR APPROVAL

DESC	A11 Transmitting Loop 50 Slotted with adhesive backing 120mm	REV:A	Client	Hi-FiD
			Material No	
			No.	

一、 DIMENSION: (mm)

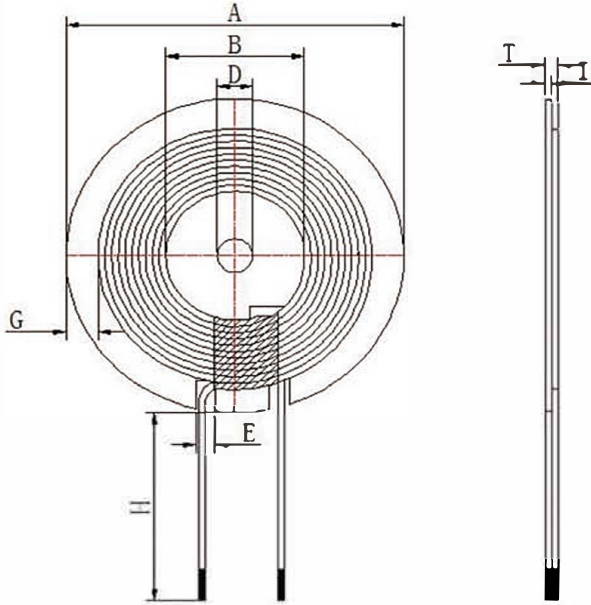

A	50.00 ± 2.00
B	23.00 ± 0.50
C	5.00 ± 2.00
D	5.30 ± 0.50
E	2.80 ± 0.50
G	5.00Min
H	120.00 ± 3.00 Cable length Customized
I	1.00MAX
T	3.00MAX

REMARK

1	Wire Diameter: 0.08*105P acetone filament cable
2	Number of coils wound: 9TS
3	Start& End Cable: Crossed
4	Wrap coil around 6MM wide with high-temperature tape
5	Tape the back of the magnetic disc with double adhesive

二、 SCHEMATIC DIAGRAM:

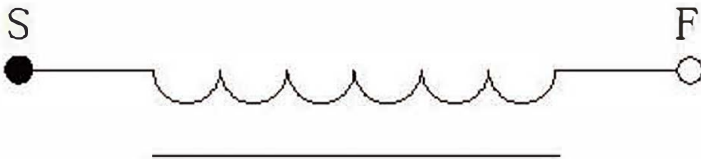

三、 Winding Specification:

NO	TERMINAL	WIRE	Tums	Winding Direction
1	S F	0.08*105P	10Ts	CCW

四、 ELECTRICAL CHARACTERISTICS:

TEMPERATURE: 25 ± 10° C, RELATIVE HUMIDITY: 65 ± 20%

NO	ITEM	TERMINAL	SPECIFICATION	TEST FREQUENCY	TEST EQUIPMENTS
1	L	S-F	7.3 ± 10% μH	100KHz/1.0V	■ TH2817B
2	Q Value	S-F	70 (Min)	100KHz/1.0V	■ TH2817B
3	DCR	S-F	50mΩ (Max)	@25° C	■ CH-502BC
4	OPERATION FREQUENCY		113KHz-205KHz		