

## 5.2 Control interface

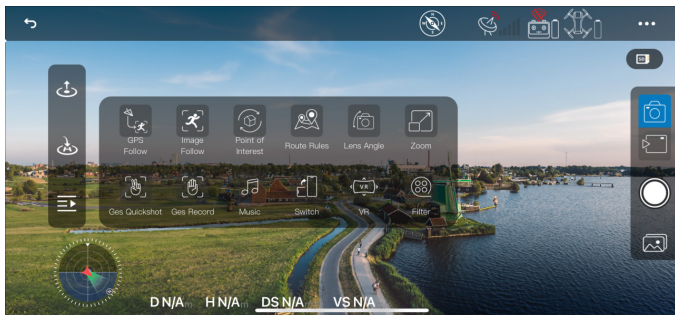

	Back		GPS Status
	Controller Battery Level		Aircraft Battery Level
	Auto Takeoff/Landing		Return to home
	Shutter		Photo/video
	Photo Album		
	Compass Interference Value	A higher value indicates greater ambient interference . Reaching 200 will prompt compass calibration, and reaching 400 will force entry into compass calibration	
	D 0.0 <sub>m</sub> H 0.0 <sub>m</sub> DS 0.0 <sub>m/s</sub> VS 0.0 <sub>m/s</sub>	D : Distance H : Height DS : flight speed VS : ascent and descent speed	
	1. SD card capacity display 2. Format : Click to format when the memory card is loaded and cannot be recognized or save files		

## Attitude Indicator

- Display information of the orientation of the aircraft, and position of the remote controller.



## Safety

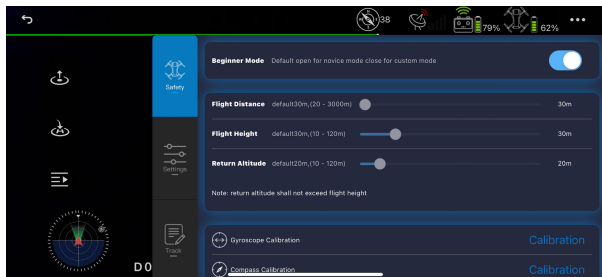

- **Beginner Mode** : In this mode, the aircraft' s farthest flight distance and altitude is 98ft so that the aircraft can fly more safely within sight.
- **Flight Distance**: Set the longest distance to fly.
- **Flight Height** : Set the maximum flight height.
- **Gyroscope Calibration** : When the drone is unstable, it can be placed horizontally to re-calibrate.
- **Compass Calibration** : Calibrate the compass first when flying in a new location or complex environment.

## Settings

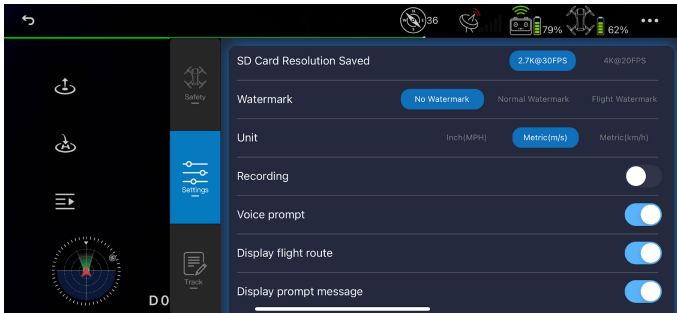

1. SD Card Resolution Saved: Set the smooth mode or default mode.
2. Watermark; Choose from 2 kinds of watermarks.
3. Unit: Switch between metric and imperial units of measurement.
4. Recording: When recording a video, you can record the sound into the video.
5. Voice prompt: Voice prompts the status of the drone when the APP is opened or closed.
6. Display prompt message: Switch on or off the prompt bar.

## Track

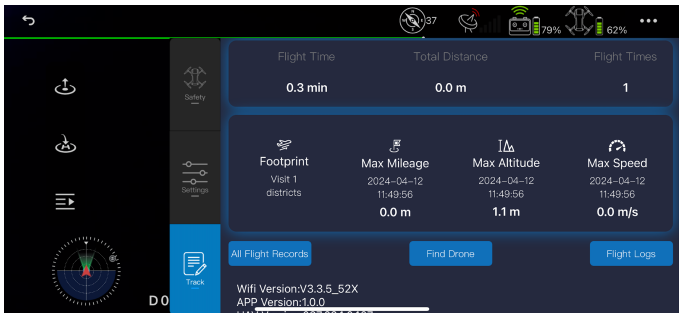

- Flight records;
- All Flight Records: The date, location, distance, duration and maximum altitude of each flight.
- Find Drone: It shows the last position of the aircraft when it lost the image transmission signal. Open the map to find the position where the aircraft is disconnected from the App.
- Flight Logs: You can export the flight log data.
- Drone information display: APP version, Wi-Fi version, ID number.



- Before using the RUKO U11 app, please correctly enable the required permissions for the app:
- Allow RUKO U11MINI to get your location. Otherwise, the following functions cannot be realized.
- Allow RUKO U11MINI to connect to the mobile phone on the local network, otherwise you will not be able to see the aircraft image transmission screen.
- Allow RUKO U11MINI to access to albums, recordings and other permissions.
- When using the RUKO U11 app on your phone, please keep your phone running smoothly and close other background software that you do not use.
- The map used in the map interface needs to be downloaded from the Internet. Before using

## 6 Flight

- After the installation preparation is complete, please conduct flight training or training first. It is recommended to conduct training in the beginner mode. Please choose a suitable flight environment when flying. The flying altitude is limited to 393ft, and the local laws and regulations must be strictly observed during flight. Please be sure to read the U11MINI Disclaimer and Safety Summary, and understand the safety precautions before flying.

### 6.1 Flight Environment Requirements

1. Do not fly in severe weather such as strong wind, snow, rain, and fog.
2. Choose an open place with no obstructions around as the flying field. The compass and GPS signals on the Aircraft will be interfered by buildings, mountains, and trees. It is recommended to fly in an open space with a diameter of 32 ft without interference. It is recommended that the flight altitude be greater than 49 ft to avoid ground obstacles and other signal interference from the ground.
3. When flying, keep in sight and control, and stay away from obstacles, crowds, etc. When flying on the water surface, please be more than 9 ft above the water surface.
4. The Transmitter may be interfered by high-voltage lines, communication base stations or transmission towers. Please fly away from these areas.
5. Please fly below 6561 ft above sea level to ensure that the Air pressure setting function of the Aircraft can work normally.
6. When GPS is active, the Aircraft can achieve stable hovering, intelligent return to home, and intelligent flight functions. When the GPS function fails, these functions cannot be implemented. The Aircraft will be unable to hover, drifting away in the direction of the wind.

## 6.2 Pre-Flight Checklist

1. Whether the remote controller, intelligent flight battery, and mobile device are fully charged.
2. Make sure that the aircraft arms are fully extended. Make sure that the battery compartment cover is fastened firmly and the intelligent flight battery is installed firmly.
3. Ensure that the propeller is free from damage, aging, deformation, no foreign matter entanglement, and secure installation.
4. Please make sure that GPS is turned on to avoid that it would be lost, please fly outdoor in an open place.
5. Whether the 4 motors can start normally after power-on, and whether the rotation speeds are consistent.
6. Ensure that the data cable between the mobile phone and the remote control is firmly installed and successfully connected.
7. Make sure the camera is clean.
8. If you need to replace parts, be sure to use original parts. The use of non-original accessories may cause danger to the safe use of the Aircraft.
9. For details on accessory support, please refer to the accessory support page in the appendix of the user manual.

## 6.3 Pairing

- Match the aircraft with the transmitter and mobile phone
  1. Long press the power button of aircraft, the motor light will be on and you will hear a power-on sound, indicating that the aircraft has been turned on;
  2. Long press the transmitter power button once to turn on the Transmitter switch;
  3. The light of the remote control turns from flashing to steady on and emits 'drop'; indicates that the frequency is successfully matched.

## 6.4 Connection & Settings

1. Connect the phone with the remote control via data cable and then set up.

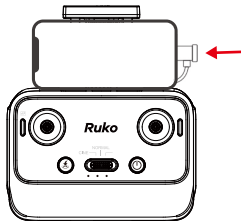

2. Tap the APP, the first time to use the interface will pop up the permission setting.



## Please allow the following permissions

- 1.mobile phone location rights
- 2.network rights
- 3.recording rights
- 4.album access rights

## IPhone Settings

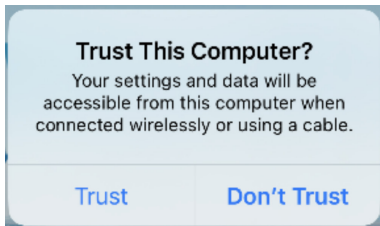

## Android phone USB Settings

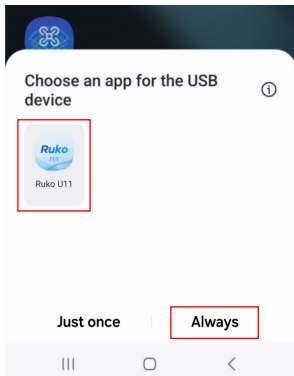

3. When you enter the operation interface and see the image transmission screen of the drone, the connection is successful.



1. When connecting the data cable, ensure that the plug of the data cable is in place.
2. For some mobile phones, due to the reasons of the phone case, the plug of the data cable is not installed in place, resulting in data transmission failure, poor contact, and no way to see the transmitted image.
3. Please set the permissions required by the APP correctly to avoid the inability to preview the image
4. USB Settings on some Android phones are hidden in the "Developer options", you need to change the "Default USB configuration" to "Transferring files" after opening the developer mode.  
(The way to open "Developer options" varies depending on the phone model. You can search Google for details.)

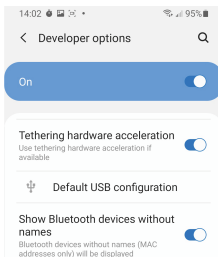
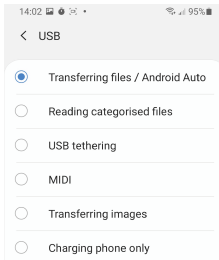

## 6.5 Calibration before flight

### Calibrate the compass

- When the drone flies in a complex environment or when the magnetic field interference exceeds the set value, it is necessary to calibrate the compass.

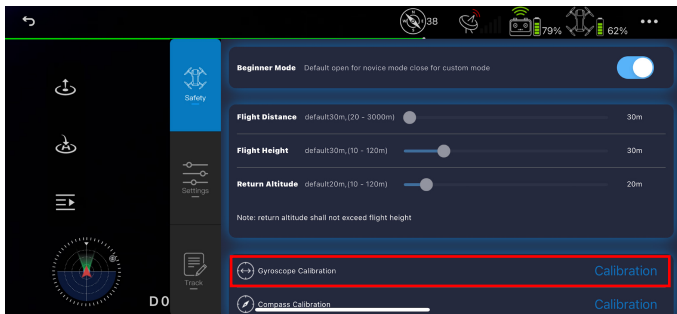

- Push the left and right joysticks to the "11 o'clock" and "1 o'clock" hold for 2 seconds (as shown in picture 1) or tap "Compass calibration" on the APP calibration interface (as shown in picture 2) to turn off the green light of the drone and enter the calibration step;

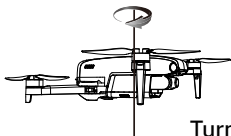

Turn 3 times

- At this time, you need to follow the prompts to pick up the Aircraft at a distance of 3.28 ft from the ground and rotate the Aircraft horizontally for 3 laps until the app interface prompts to enter the vertical calibration.
- Pick up the Aircraft at a distance of 3.28 ft from the ground, and rotate the Aircraft 3 laps vertically with the camera facing upwards until the prompt of vertical calibration on the app interface disappears. After the compass calibration is completed, place the Aircraft on a level ground. At this time, the three lights of the drone flash in turn.



**Turn 3 times**



- Before the flight, pay attention to the compass interference value on the APP. (  )When the interference value is close to 120, we can manually calibrate the compass, or change the environment to fly. When the interference value exceeds 180, the drone will automatically enter the compass calibration.
- When the Aircraft is flying in a circle or out of control in a complex environment, the aircraft compass calibration is not standard or interfered. Please land the Aircraft manually in time to manually calibrate the Aircraft (refer to the first step of calibrating the compass).
- When calibrating the Aircraft, please open the arm and keep the aircraft 1 meter above the ground to avoid the influence of the magnetic field of the motor.

## 6.6 Calibrate the gyroscope

### Calibrate the gyroscope

1. Make sure that the Aircraft is placed on a level ground.
2. It can be calibrated by gyroscope calibration function of APP.

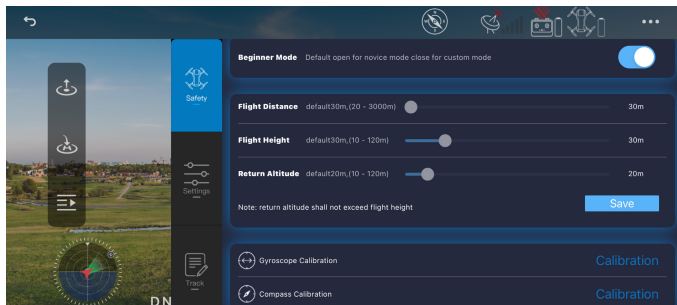

- Or push the right joystick of the remote control to the "5 clock" position for calibration.
3. The rear light flashes quickly, and the drone enters horizontal automatic calibration
  4. The light changes back to the original light state, indicating that the calibration is complete
  5. "Fly" is displayed in the app, and you can now prepare to take off.



- When the Aircraft's flight state is tilted and unstable, please land the Aircraft on a level ground for gyroscope/horizontal calibration.
- When the tilt Angle of the fuselage is greater than  $10^\circ$ , the horizontal correction cannot be performed.

## 6.7 Starting/Stopping the Motors

### Starting the Motors

- Push the joysticks into 5 & 7' o clock positions to start the motor. After the motor starts, please release the rocker immediately.

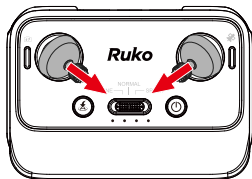



- Stopping the Motors  
After the motor starts rotating, there are two ways to stop:
  - Method 1: After the Aircraft takes off, push the throttle stick to the lowest position and operate the Aircraft to land until the motor stops, then release the joystick.
  - Method 2: When the flight is not taking off, Push the joysticks into 5 & 7' o clock position to stop the motor. After the motor is turned off, please release the joystick immediately.



- When manually landing the aircraft, continue to pull down the remote control throttle lever, landing 1.6 ft (0.5 meters) will stop, confirm the landing continue to pull down the throttle lever, the drone will land and stop the motor.
- Please choose the flat surface to landing.

## 6.8 Auto Takeoff/Landing

### Auto Takeoff

- After the Aircraft is calibrated, users can use the take-off function on the app:
  1. Start the motor after confirming the safe take-off conditions.
  2. Tap “” on the App to take off.
  3. Slide to unlock motor.
  4. Click the One-key Takeoff button on remote controller or enter the app and click  to take off.
  5. The Aircraft will take off automatically and hover at a distance of 1.5m(4.9ft) from the ground.

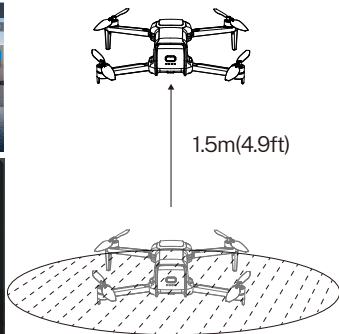
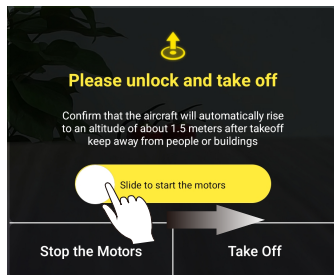
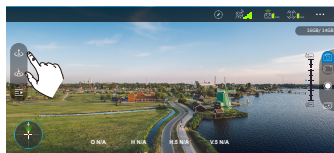

## Auto Landing

- After the aircraft takes off, the user can choose to use the automatic landing function on the app:
- Confirm the safe landing conditions, tap the “

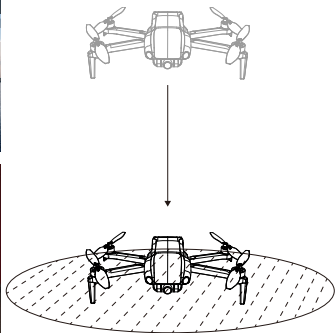
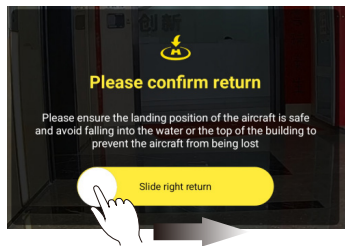



## 6.9 Basic Flight Steps

### Basic Flight Steps

1. Place the Aircraft on a flat and open ground with the nose facing forward and the tail facing the pilot.
2. Press and hold to turn on the aircraft power.
3. Long press to turn on the remote control power, the drone and the remote control will automatically match the frequency, the time is about 50 seconds.
4. After a successful match, connect the phone to the remote control through the data cable (pay attention to the USB permission setting)
5. Open the RUKO U11 App, and enter the operation interface.
6. GPS signal search is completed, and the drone light is green and on.
7. Unlock and start the motor.
8. Slowly push the throttle stick upward to let the Aircraft take off smoothly.
9. Pull down the throttle stick to lower the Aircraft.
10. After landing, pull the throttle stick to the lowest position and hold it until the motor stops.
11. Turn off the power of Aircraft and Transmitter in turn after ⑨ shutdown.

## Aerial Photography Tips & Tricks

1. Perform pre-flight inspection.
2. It is recommended to take photos or videos in low-speed or medium-speed gear.
3. Choose sunny and less windy weather for shooting.
4. Push the stick as little as possible during the flight to make the Aircraft fly smoothly.



**Awareness of flight safety is very important for the safety of you, the surrounding people and the environment. Please read the "Safety and Disclaimer Guidelines" carefully.**

# 7 Appendix

## 7.1 Specification Parameter

Drone	Model	U11MINI
	Weight (Including Battery)	<250g
	Motor Model	1503
	Operating Temperature Range	50° to 104°F (10° to 40°C)
	Satellite Systems	GPS / GLONASS
	Dimensions (L x W x H)	Unfolded: 31 x 20.5x 5.7 cm Folded: 14.1x8.7 x 5.7 cm
Camera	Controllable Range of Camera (Up and down)	About -90° TO +0°
	Focus Range	Fixed-focus
	Resolution of Photo	Phone 3840 x 2160 P
		SD Card 3840 x 2160 P
	Resolution of Video	Phone 1280 x 720 P
		SD Card 3840 X 2160 P / 20FPS 2976x1680P / 30FPS
	Photo Format	JPEG
	Video Format	MP4
Supported SD Cards	Micro SD card(Class 10/U1 or later) 64G	
Supported File Systems	FAT32	
5G Transmission	Operating Frequency	5.15-5.35 GHZ; 5.725-5.825 GHZ
	Video Transmission Frame Rate	20 FPS
	Operating Frequency	5.8G
	Max Operating Distance	Up to 3KM (Outdoor and Unobstructed)
	Battery	3000mAh Li-polymer
Remote controller	Charging Time	About 4 Hours
	Operating Time	About 3.3 Hours
	Operating Voltage	3.7V
	Mobile Device Holder	4.7 to 6.7 Smart Phones
	Operating Temperature	32° to 104°F (0° to 40°C)

Drone Battery	Capacity	2200mAh
	Voltage	7.6V
	Battery Type	Li-polymer
	Power	16.72Wh
	Net Weight	95 g /3.35 oz
	Max Charging Power	7.5W
	Max Charging Time	"About 3 Hours(Depending on Charging Power)"
	Charging Temperature Range	50°to 104°F (10°to 40°C)
Charging Cable	Interface Type	Type - C
	Input	100 - 240V, 50/60Hz, 0.5A
	Output	5V/1.5A or 5V/2A or 5V/3A
	Rated Power	≤ 15W
APP	APP Name	RUKO U11
	Mobile Phone System	"Android 6.0 And Above System IOS 10.0.2 And Above System
	Transmission Distance	"Up to 3KM (Outdoor and Unobstructed)"
	Connection Mode	Data line Connection

## 7.2 Accessories



Intelligent Flight Battery

Spare Propeller

Remote Controller

- The above accessories can be purchased by searching on Amazon and entering Ruko store.
- Always use original accessories. The use of non-original accessories may pose a risk to the safe use of the aircraft.

## 7.2 Common Problems and Solutions

Question	Reason	Solutions
The motors cannot be started	Without GPS signal	Turn on the drone in an open area with a strong GPS signal, and signal full 3 bars or more to enable take-off.
	The red light stays on	The drone has low battery. Please charge the battery in time.
	The green light goes out	To begin compass calibration. Please refer to the Compass Calibration section of the user manual.
	The left and right joysticks are not in place	Push the left and right joysticks simultaneously to 5 o'clock and 7 o'clock for 2 seconds. Or use the one-click unlock take-off function on the APP.
Unstable flight	Flying too low, affected by aircraft airflow	Please fly the aircraft above 9.84ft(3 meters)
	The gyroscope is not calibrated	Place the aircraft on a horizontal surface and conduct gyroscope/horizontal calibration. Please refer to the "Gyroscope Calibration " section of the user manual
	The propellers become deformed and incomplete	Replace the propellers with new ones
	GPS signal is unstable. Flying near buildings and in obstructed places	Please fly the aircraft in an open area free of obstacles within the circle of radius 32.81 ft(10 meters)
Fly not far, fly out a distance to bounce back	In beginner mode, you will only be able to fly 30 metres in height and 30 metres in distance.	Enter the setting interface of APP, close the beginner mode, set the flight distance and height, and save the Settings.
During flight, the direction of the drone 's flight is opposite or different to the direction of the remote control.	4 propellers are installed backwards or a wrong propeller is installed	When installing the propeller, install it according to the corresponding mark
The drone suddenly crashed	1, The battery is not installed properly. 2, The propeller is not securely installed and falls off.	Check whether the battery or propeller is abnormal, and re-test after firm installation.

Question	Reason	Solutions
Out of control, spinning around on its own, abnormal sound	The remote controller signal is interfered or the aircraft exceeds the range of remote control	Please fly the aircraft outdoors without interference, and ensure that it is within a controllable range
	Compass interference	Please manually land the aircraft in time and calibrate the compass. Please make sure to fly away from the buildings, trees, power lines, and signal towers
	The propellers become deformed and incomplete	Replace the propellers with new ones
The photo captured by the drone was unusually blurry	The camera cover is not removed	Remove the camera cover before flying.
	The camera lens is dirty.	Use a clean cloth to clean the lens.
Video freezes, image transmission distance is short	The aircraft is out of Wi-Fi range	Fly the aircraft within the range of the Wi-Fi
	Wi-Fi image transmission signal interference	Fly the aircraft in an unobstructed open area free of buildings, high-voltage wires and signal towers
	The remote controller and the mobile phone are not pointed at the direction of the aircraft	Point the remote controller and the mobile phone at the flying direction of the aircraft to maintain the strongest signal connection
	Phone performance freezes	Close unused apps running in the background to maintain the best performance of the phone
No image is displayed on the App.	The phone is not connected to Wi-Fi	The phone and the remote control need to be connected via data cable.
	The phone settings conflict with the APP	Try turning on airplane mode on your phone.
	Wrong app downloaded	Download the correct app (RUKO U11)
	The drone cannot be paired with the remote controller	It takes about 40 seconds for the drone and the remote control to match, and the image captured by drone will be displayed once the match is successful.
APP crashes or functions abnormally	Wrong app downloaded	Download the correct App(RUKO U11)
	Some phone versions are old and incompatible with APP	Please provide version and model of the phone, we will try to help you to solve it.
GPS signal is weak	When the drone is indoors.	GPS signals cannot be found indoors. Please search for GPS signals in an open area.
	Under the tree, next to the building, in an obstructed place	Please stay away from obstacles for more than 32.81 feet(10 meters), and search for GPS signals in an open area.

Question	Reason	Solutions
Unable to return home, drifting and flying away	GPS signal was turned off during the flight	Please don't turn off GPS suddenly during outdoor flight. Switch back to GPS mode in time.
	Flying next to buildings, there are covered areas under trees that cause GPS signals to be lost or unstable	Fly away from buildings or covered areas.
The remote control and the drone take a long time to match	It takes about 5 seconds to match the remote to the drone	Please wait patiently.
Unable to charge battery/Not fully charged	Using inferior charger or charging on the computer with unstable voltage output	Use a mobile USB charger that ensures constant stable voltage output(5V) and amperage output(2-3A)
	Using inferior charging cables	Please use the original factory charging cable to charge
Short battery life	Flying in windy weather	Flying in windy weather will accelerate power loss
	The drone was not be charged when you received it	The batteries are fully charged with the correct USB charger before flying.
	Flying in cold weather	In low temperatures, the chemical reaction of the lithium battery is slowed down and the energy cannot be fully released
The product has slight marks	We tested all drone before shipping	In order to give you the best experience, we tested functions of all drone before shipping. Therefore, it is inevitable that there will be slight traces. However, it can be guaranteed that all drone are 100% brand new

The aircraft complies with Part 15 of the FCC Rules. Operation is subject to the following two conditions: (1) this device may not cause harmful interference, and (2) this device must accept any interference received, including interference that may cause undesired operation.

Changes or modifications to this unit not expressly approved by the party responsible for compliance could void the user's authority to operate the equipment.

NOTE: This equipment has been tested and found to comply with the limits for a Class B digital device, pursuant to Part 15 of the FCC Rules. These limits are designed to provide reasonable protection against harmful interference in a residential installation. This equipment generates, uses and can radiate radio frequency energy and, if not installed and used in accordance with the instructions, may cause harmful interference to radio communications. However, there is no guarantee that interference will not occur in a particular installation. If this equipment does cause harmful interference to radio or television reception, which can be determined by turning the equipment off and on, the user is encouraged to try to correct the interference by one or more

- of the following measures:
- Reorient or relocate the receiving antenna.
  - Increase the separation between the equipment and receiver.
  - Connect the equipment into an outlet on a circuit different from that to which the receiver is connected.
  - Consult the dealer or an experienced radio/TV technician for help.

This device and its antenna(s) must not be co-located or operation in conjunction with any other antenna or transmitter.

#### Radiation Exposure Statement

To maintain compliance with FCC's RF Exposure guidelines, This equipment should be installed and operated with minimum distance of 20cm from your body.

The motor complies with Part 15 of the FCC Rules. Operation is subject to the following two conditions: (1) this device may not cause harmful interference, and (2) this device must accept any interference received, including interference that may cause undesired operation.

Changes or modifications to this unit not expressly approved by the party responsible for compliance could void the user's authority to operate the equipment.

NOTE: This equipment has been tested and found to comply with the limits for a Class B digital device, pursuant to Part 15 of the FCC Rules. These limits are designed to provide reasonable protection against harmful interference in a residential installation. This equipment generates uses and can radiate radio frequency energy and, if not installed and used in accordance with the instructions, may cause harmful interference to radio communications. However, there is no guarantee that interference will not occur in a particular installation. If this equipment does cause harmful interference to radio or television reception, which can be determined by turning the equipment off and on, the user is encouraged to try to correct the interference by one or more

- of the following measures:
- Reorient or relocate the receiving antenna.
  - Increase the separation between the equipment and receiver.
  - Connect the equipment into an outlet on a circuit different from that to which the receiver is connected.
  - Consult the dealer or an experienced radio/TV technician for help.

This device and its antenna(s) must not be co-located or operation in conjunction with any other antenna or transmitter.

#### Radiation Exposure Statement

The device has been evaluated to meet general RF exposure requirement in portable exposure condition without restriction.



# *Ruko*<sup>®</sup>

rukotoy.com

CONTACT US FOR MORE TECH SUPPORT

 +1 (888)892-0155 | Mon-Fri 7:00AM - 7:00PM (PST)

 +1 (732) 207-0697  [rukodrone@gmail.com](mailto:rukodrone@gmail.com)

