

**Ruko**<sup>®</sup>

**14+**  
for age

# User Manual

v2.0

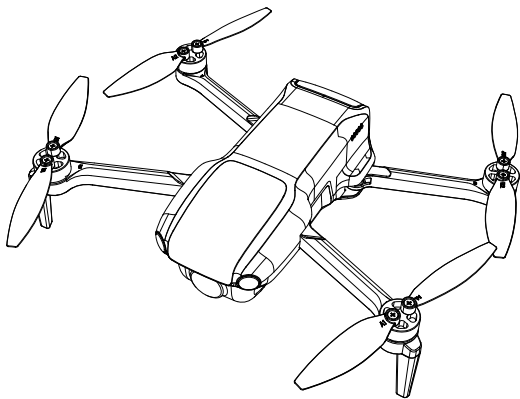

## U11MINI

CONTACT US FOR MORE TECH SUPPORT

 +1 (888)892-0155 | Mon-Fri 7:00AM - 7:00PM (PST)



rukotoy.com

CONTACT US FOR MORE TECH SUPPORT

 +1 (888)892-0155 | Mon-Fri 7:00AM - 7:00PM (PST)

 +1 (732) 207-0697



# Content

<b>1 Using This Manual</b>	1
1.1 Legend	1
1.2 Recommendations	1
1.3 Download RUKO U11 APP	1
1.4 Video Tutorials	2
<b>2 Product Profile</b>	3
2.1 Introduction	3
2.2 Feature Highlights	3
2.3 Preparing the Aircraft	4
2.4 Aircraft Diagram	5
2.5 Remote Controller Diagram	6
<b>3 Aircraft</b>	8
3.1 3 Types of Flight Speed Mode	8
3.2 Aircraft Status Indicator	8
3.3 Automatically Return to Home	10
3.4 Optical Flow Positioning /TOF (Indoor Attitude Mode)	16
3.5 Intelligent Flight Mode	18
3.6 Propeller	23
3.7 Intelligent Flight Battery	25
3.8 Camera Overview	30

<b>4 Remote Controller</b>	32
4.1 Remote Controller Profile	32
4.2 Using the Remote Controller	32
4.3 Communication Range of remote controller	37
4.4 Matching the Remote Controller	38
<b>5 RUKO U11 APP</b>	39
5.1 Home	39
5.2 Control Interface	40
<b>6 Flight</b>	45
6.1 Flight Environment Requirements	45
6.2 Pre-Flight Checklist	46
6.3 Calibration before Flight	47
6.4 Auto Takeoff/Landing	47
6.5 Manual Operation of Starting/Stopping the Motors	50
6.6 Basic Flight Steps	52
<b>7 Appendix</b>	58
7.1 Specification Parameter	58
7.2 Accessories Support	59
7.3 Common Problems and Solutions	60

# 1 Using This Manual

## 1.1 Legend

- ✓ Recommend    ✗ Warning    ⚠ Hints & Tips    📖 Reference

## 1.2 Recommendations

- RUKO U11MINI provides users with instructional videos and the following documents:
  1. «User Manual»
  2. «Quick Guide & Safety Disclaimer»
- It is recommended that users first watch the instructional video and then read the «Quick Guide & Safety Disclaimer» to understand the use process. Please read the «User Manual» for more details.

## 1.3 Download RUKO U11 APP

- Make sure to use RUKO U11 App during flight. Scan the QR code or Search in the Application store to download "RUKO U11".
- RUKO U11 app is compatible with Android 6.0 or above, iOS 10.0.2 or above.



( For Android )



( For iOS )

## 1.4 Video Tutorials



- According to the corresponding aircraft, visit the link or scan the QR code below to locate the model to watch tutorial videos or get more technical support, which how to use the aircraft safely.  
<https://rukotoy.com/support>

## 2.Product Profile

### 2.1 Introduction

- U11MINI could hover and fly stably indoors and outdoors, with RTH function. The camera uses an upgraded 5GHz Wi-Fi FPV real-time transmission function, equipped with a 120°FOV lens and a 90° adjustable camera, which can stably shoot 4K HD video and 4K ultra-clear images, providing you with a broad field of vision for unforgettable moments.

### 2.2 Feature Highlights

- U11MINI aircraft adopts folding design, ultra-light and small body weight within 250g, easy to carry. Easy to use, you can take photos and videos with one click.
- U11MINI's leading flight control system provides agile, stable and safe flight performance. The RTH function enables the aircraft to automatically return to the return point and land even when the remote control signal is lost or the power is insufficient.

## 2.3 Product List



Drone



Remote Controller



Intelligent Flight Battery



Camera Cover



Spare Propeller



USB Charging Cable



Screwdriver



Screw



User Manual



Quick Guide & Safety Disclaimer



## 2.4 Preparing the Aircraft

- All propellers are folded before the aircraft is package. Follow the steps below to prepare the aircraft.

1. Unfold the front arms;
2. Unfold the rear arms, and then all the propellers.
3. Remove the camera cover from the aircraft's camera.

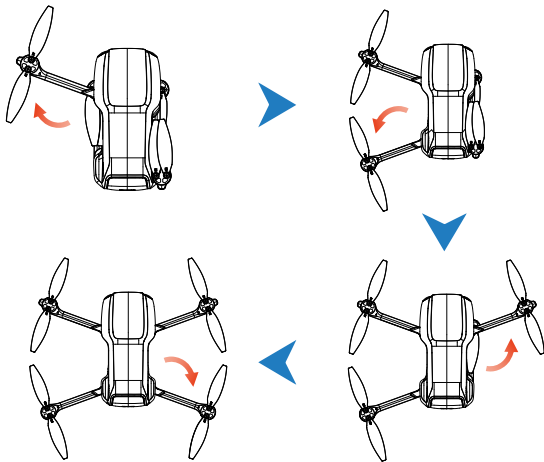

1. Unfold the front arms before unfolding the rear arms.
2. Before powering on the aircraft, ensure that the front and rear arms are extended and the aircraft is placed on the horizontal ground.

## 2.5 Aircraft Diagram

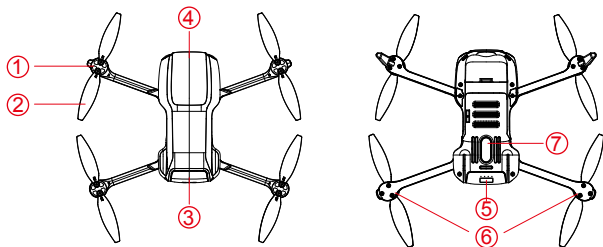

- ① Motor
- ② Propellers
- ③ Battery
- ④ Camera
- ⑤ Power Button
- ⑥ Rear Indicator Light
- ⑦ Optical Flow Lens/TOF

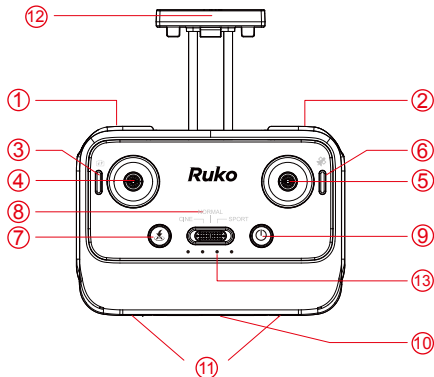

## 1. Gimbal Dial

### 2. Take Photo/Video

Short press once to take a picture.  
Long press once to start recording mode, repeat to stop recording.

### 3. One-touch Adjustment of the Gimbal

Press to automatically adjust to the maximum angle towards the bottom, repeat to restore the horizontal angle.

### 4. Left Control Joystick

(American control joystick) Use a control joystick to control aircraft movements. The left control joystick is the throttle lever, which can adjust the aircraft's altitude and nose direction (Up/Down, Left Rotation/Right Rotation).

### 5. Right Control Joystick

The right stick controls the drone's flight direction (forward/backward/left/right).

### 6. GPS Mode/Indoor Attitude Mode

Press and hold the button for 3 seconds to turn off the GPS (GPS is on by default when the power is on, please do not turn it off when flying outdoors to avoid losing the drone). Press and hold the button again for 3 seconds to turn on GPS.

### 7. One Key Return

Shortly pressing, the drone automatically returns to the take-off position (due to GPS signal problems, the landing position may slightly deviate from the take-off position, the deviation range is about 9.84ft in diameter); short press once during the return to cancel the intelligent return.

### 8. Speed Adjustment (3 speed in total)

Left: low-speed  
Middle: medium speed  
Right: high speed

### 9. Power Switch

Long press to turn on the power, repeat to turn off

### 10. Charging Hole

### 11. Joystick Storage Hole

### 12. Cell Phone Holder

### 13. Indicator Light

## 3 Aircraft

- RUKO U11MINI aircraft is mainly composed of a flight remote controller, a communication system, a video downlink system, a propulsion system and an Intelligent Flight Battery. This section describes the functions of each section in details.

### 3.1 Flight Speed Mode















- RUKO U11MINI has three types of speed: low speed, medium speed and high speed, which can be adjusted by pressing the speed button to meet your different flight speed experience.



1. When wind speed is high, sport mode should be maintained to improve wind resistance effect. High speed mode is sport mode.
2. When flying in sport mode, the pilot should reserve at least 3 meters of braking distance to ensure flight safety .
3. When flying in sport mode, the power of the aircraft will be greatly improved, please reserve enough flying space to ensure the safety of the flight.



### 3.2 Calibration and Aircraft Status Indicator

- The U11MINI aircraft's status indicator is located under the rear arm of aircraft to indicate the current status of the flight control system. Please refer to the following table for the status of the flight control system represented by different blinking modes.

	Blinking status of the indicator		Conditions
Aircraft		The red light blinks twice at short intervals	The remote controller and the drone are starting to match.
		Slow flash	Once the match is successful, search the GPS signal.
		Slow flash	Drone low battery
		Stay on	Complete GPS signal search
		Green light out	Start compass calibration.
		Stay on	Indoor attitude model
		Quick flashing	Start gyroscope calibration.
Remote Controller		Flash	GPS search in progress
		Stay on	Star search successful. Clear for takeoff
		Extinguish	Turn off GPS and enter attitude mode
		Often lit or one by one off	Display remote control battery level
		Flash quickly together	The remote controller and the drone are starting to match.
		Blue light blinking + green steady on	Frequency success, star search phase
		Three green lights flashing slowly together	Drone low battery
		Three green lights flash in turn	The drone is returning
		Blue light and three green lights flash in turn	The remote controller is charging

### 3.3 Return to Home

- The U11MINI aircraft has an automatic return-to-home function in GPS mode, making the aircraft return to the take-off point. The Return to Home (RTH) function brings the aircraft back to the last recorded home point. There are three types of RTH: Smart RTH, Low Battery RTH, and Signal Disconnection RTH. If you activate the RTH function under the condition that the aircraft successfully recorded the home point and GPS signal is good, the aircraft will automatically return to the home point and land.

	GPS	Description
		<p>When flying outdoors, the GPS signal icon is displayed with <b>3 bars</b> or more for the first time, and the take-off location will record the aircraft's current position as the Home Point. During the flight, if the aircraft lands at a new location, the point from which it retook off will become the latest home point, and the aircraft will return to the latest home point.</p>

## Smart RTH

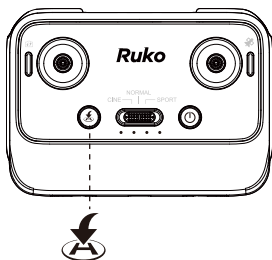



### Return

During the flight, press the "  " button, the remote control will make a "di" sound, and the aircraft will return to the take-off point automatically. During the return flight, the power indicator of the remote control will flash cyclically.

### Stop return

To stop the return flight, just press this button again.

1. When the pilot needs the aircraft to return home automatically, you can click the smart RTH button(  ) on remote controller or tap the return icon(  ) on the APP interface to start RTH.
2. During the return process, the user can operate the aircraft to ascend, descend, forward, backward, fly to the left or right to avoid obstacles.
3. During the return home, short press the smart return button on the remote controller or click the return icon (  ) on the U11MINI interface again to exit the return home.

**Note:**

- If the flight altitude is below 65 feet (20 meters), the aircraft will automatically ascend to the default return altitude of 65 feet (20 meters) before returning home. When the return altitude is not set.
- 65ft (20m) is the default return height. The return height range that can be set in the APP is 10-120 meters.

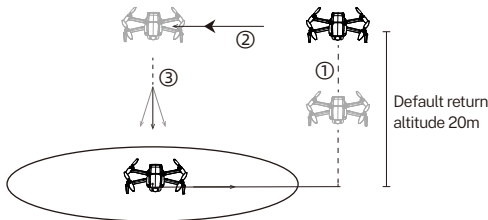

- If the flight height of the drone is lower than the set flight height, the drone will rise to the set flight height and then return to the take-off point. If the height of the drone exceeds the set flight height, it will return to the take-off point from the existing height.

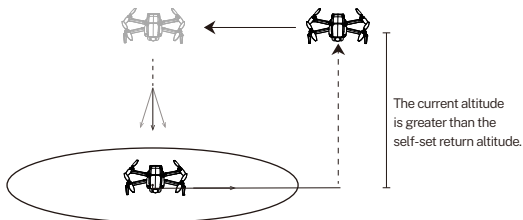

- The drone is not equipped with an obstacle avoidance function. During the flight, please judge the flight situation reasonably, avoid obstacles in time, and set the corresponding flight and return height according to the flight environment.



## Low Battery RTH

- When the intelligent flight battery is too low or there is not enough power to return home, the user should land the aircraft as soon as possible to avoid aircraft damage or other dangers.
- In order to prevent unnecessary dangers due to insufficient battery power, when the aircraft battery power is low, the low battery return home function will be automatically triggered. According to the remaining power after returning, there are 2 situations after returning:
  1. First-level low battery: the aircraft returns to the point 98 feet (30 meters) above the take off point and hover. After hovering, you can continue flying the aircraft at a height of 98 feet (30 meters) and within a radius of 98 feet (30 meters).

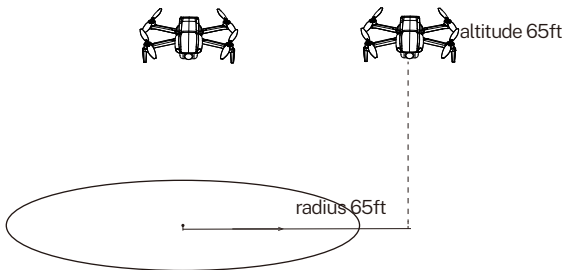

2. Second-level low battery: the aircraft will fly directly from the current altitude to the point above the Home Point and then descend to the ground.

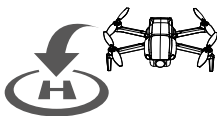

### Low battery



- Must pay attention to the flight altitude when the battery is low. Avoid hitting obstacles due to the low flying altitude when returning home with the second-level low battery.
- The remaining power after returning is related to the return distance, wind speed, and wind direction.

### Lost Signal RTH

- When the remote controller has low battery or is turned off or loses signal for 10 seconds, the aircraft will enter the auto-return mode and return to the take-off point. If the signal is recovered during the return home process, you can press the return button to cancel the return, and the remote control can control the aircraft again at this time.

## Automatically Return to Home:

1. Aircraft stores its position when taking off after the GPS signal is successfully received, and records it as the home point.
2. Loss of signal will trigger RTH 10 seconds later. (triggered by low battery of remote controller, signal loss, etc.).
3. After triggering the Return-to-Home function, the aircraft adjusts the nose direction and starts to return home.
4. The aircraft automatically flies over the home point, then starts to land, and completes the home return.

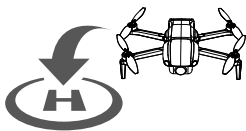

### Note:

- When out of control, the aircraft cannot avoid obstacles.
- When the GPS signal is weak, the aircraft cannot return to home automatically

### 3.4 Optical Flow Positioning /TOF (Indoor Attitude Mode)

- The underside of the aircraft is equipped with a downlook optical flow system and a TOF altitude sensor, which allows the aircraft to better adapt to its environment.
- The downlook optical flow system, consisting of downlook vision camera sensors, enables the drone to hover stably at low altitude in indoor attitude mode without GPS.

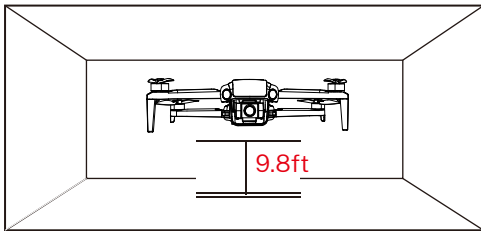

#### Note:

1. The optical flow vision system can only assist flight when the surrounding environment is well lit and rich in texture, can not completely replace the user's judgement, please pay attention to the aircraft situation and APP tips, do not over-rely on optical flow vision system.
2. Optical flow vision system in the environment light is too bright, too dark, mirror, solid colour smooth ground, water, poor or ineffective effect in scenes such as reflective surfaces and sparsely textured surfaces.

3. The optimal working range of the optical flow vision system is below 0.5-3 meters, beyond the range, the positioning of the optical flow vision system may be poor, please fly carefully.
4. Please make sure that the optical flow vision system lens is clear, and do not block or interfere with the optical flow vision system.
5. The optical flow vision system can only be used in the attitude mode, and the GPS fixed point mode can be used after the drone successfully searches the GPS signal in the outdoor GPS mode.



- If the GPS signal is weak and you are flying indoors, you will need to manually turn off the GPS and switch to the indoor attitude mode before take-off.
- Once GPS is turned off, the drone will not be able to return automatically, and the smart flight feature will not be used.

## 3.5 Intelligent Flight Mode

- U11MINI has 5 intelligent flight modes to meet the user's shooting needs: Route Rules, GPS Follow, Point of Interest, Ges Quickshot/Ges Record and Image Follow. According to the user's shooting needs, the operation can be completed by one click, which is simple and fast.



- **Route Rules:** In this mode, aircraft flies along paths marked with way points.



- **GPS Follow:** In this mode, the aircraft will lock on to the user and automatically follow the operator's movement trajectory to capture and shoot.



- **Point of Interest:** In this mode, the aircraft is centered on the location set on the app, flying around at a specific distance to shoot.



- **Ges Quickshot/Ges Record:** The aircraft takes pictures or videos according to the steering instructions of different gestures.



- **Image Follow:** Image Follow function enables the drone to follow the object's in circle movement to rotate.

## Route Rules





1. Ensure that you have downloaded the RUKO U11 APP on your phone;
2. Connect the phone with the remote control via the data cable and open the APP.
3. After the aircraft takes off, in GPS mode, tap the icon (  );
4. Mark interested of points (up to 16) which you plan to fly on app map's within red circle (limited flight range).
5. Tap "Delete Single Point" or "Delete All" to reset the marked point.
6. Make sure the marks are correct, click "Send", The aircraft will start waypoint flight.

Note: Push right joystick to cancel waypoint flight function.



## GPS Follow



1. Ensure that you have downloaded the RUKO U11 APP on your phone;
2. Turn on the smartphone' s GPS location; connect the phone with the remote control via the data cable and open the APP;
3. After the aircraft takes off, the best effect is to ensure that the flight range is within 10-50 meters in an open environment with good GPS signal;
4. Tap the (  ) icon on the app interface to start the (  ) mode.
5. "GPS Follow"(  )will be displayed on the app interface and try to fly. The aircraft will track your movements to fly.
6. Tap the icon on the app interface again to exit the GPS Follow mode.

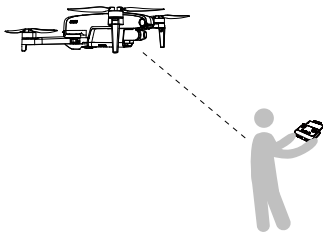

- The GPS Follow function only works when the GPS signal is strong. Please avoid high buildings, trees, and areas where Wi-Fi signal might be interfered.
- Aircraft is not equipped with obstacle avoidance function. Please use it in open areas free of obstacles.



## Point of Interest

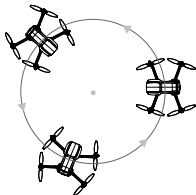



1. Ensure that you have downloaded the RUKO U11 APP on your phone;
2. Turn on the smartphone' s GPS location; connect the phone with the remote control via the data cable and open the APP;
3. Launch the aircraft and make it hover around the target center point. Fly to the target point where you want the aircraft to fly around.
4. Tap the (  ) icon on the app to activate Fly Around mode.
5. Move the right rocker forward and backward to set the radius of the drone to fly (within 5-50 meters);
6. The aircraft begins to orbit according to the radius set in step 5.
7. Tap the icon on the app interface again to exit the Point of Interest.



- The default minimum surround mode radius is 16 feet (5m).
- Move the right direction bar left and right to adjust the circling speed and direction.

## Ges Quickshot/Ges Record



1. Ensure that you have downloaded the RUKO U11 APP on your phone; Turn on the smartphone's GPS location; connect the phone with the remote control via the data cable and open the APP;
2. After the drone takes off, use it in GPS mode;
3. Open the APP, tap the Multi-function icon on the APP interface, and tap the (  ) icon. In this mode, raise the right hand and pose (  ) at the same height of the shoulder to take photos;
4. Tap the (  ) icon. In this mode, raise your right hand and show your palm at the same height of the shoulder to open the recording mode.



- Use in a well-lit environment. Tap the icon again to exit Ges Quickshot/Ges Record mode.
- Ges Quickshot/Ges Record mode can only be activated with the right hand.

## Image Follow





1. Launch aircraft and ensure flight height is higher than the nearby obstructions, access to the app CONTROL interface.

2. Click(  ), slide to start and tap on the object or person plans to track, tap to confirm the selection, drone rotates following the object's in circle movement.

Note: Make sure the size of the frame isn't too large, so as to ensure the recognition is achievable.

### 3.6 Propeller

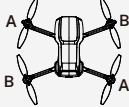
- The adjacent propellers on the motors of the U11MINI are forward and reverse propellers. The two propellers on the same motor are the same, and the propellers are marked with A and B respectively.
- The rotation directions of the propellers with the same mark are the same.

Propellers	Mark A	Mark B
		
Installation location	Installed to the motor with A mark on the arm	Installed to the motor with B mark on the arm

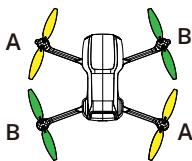
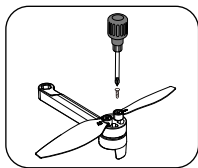

Installation location

## Attaching the Propellers

- Taking the camera direction as the front, the left front arm and right rear arm must be equipped with propellers marked with A; the right front arm and left rear arm must be equipped with propellers marked with B. Use a screwdriver to install and make sure the screws are tightened.

## Detaching the Propellers

- Use the screwdriver to detach the propellers from the motors.



- Please use the propellers provided by Ruko, and do not mix propellers of different types.
- Please check whether the propeller is installed correctly and tightly before each flight.
- Before each flight, please check to make sure that the propellers are in good condition.

## 3.7 Intelligent Flight Battery

- The U11MINI intelligent flight battery has a capacity of 2200mAh, a rated voltage of 7.6V, and with charge and discharge management functions. This battery uses high-energy and large-capacity batteries to increase the flight time of the aircraft.

### Battery Features

1. Balance Protection: Automatically balance the internal battery cell voltage to protect the battery.
2. Overcharge Protection: Overcharge will seriously damage the battery. When the battery is full, remove the charger device in time.
3. Over-discharge Protection: Over-discharge will seriously damage the battery. When the battery is not used for flight, the battery will automatically discharge to protect the battery life.
4. Short Circuit Protection: When the battery detects a short circuit, the output will be cut off to protect the battery.
5. Easy Charging: No need for a dedicated power adapter, just Android charger and USB charging head.



- Please read carefully and strictly abide by Ruko's Requirements in this User Manual, Quick Guide & Safety Disclaimer, and stickers on the battery surface before using the battery. The user shall bear the consequences caused by failure to use it as required.

## Using the Battery

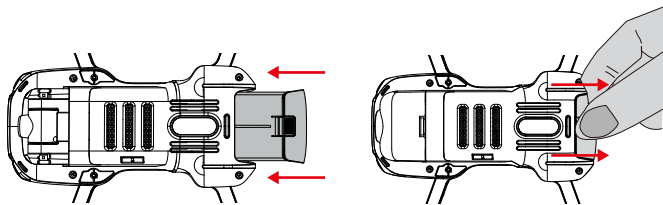

- Install the intelligent flight battery into the battery compartment and push it down until you hear a "click" from the battery buckle, indicating that it pops up and locks. Make sure the battery is in place.
- To remove the battery, press the buckles on both sides of the battery and pull it out of the battery compartment.



- Do not install the battery into the aircraft or remove the battery from the aircraft when the battery power is turned on. Otherwise, the poor contact of the battery interface during the operation may cause the battery to short-circuit and burn the aircraft.
- The battery must be installed or removed with the battery power turned off.

## Checking Battery Power

- Turn on the power and check the current battery.

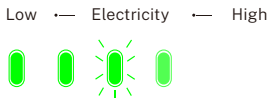
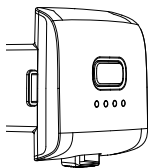

## Powering On

- Press and hold the power button, after the indicator light turns on to the fourth, release the power button to check the current battery power.

## Powering Off

- Press and hold the power button until all lights are off and release the power button. After closing, the indicators are off.

## Low Temperature Notice

1. When using the battery in a low-temperature environment ( $0^{\circ}\text{C}$  -  $5^{\circ}\text{C}$ ), make sure that the battery is fully charged. The discharge capacity of the battery will be reduced when working in a low-temperature environment.
2. In a low-temperature environment, due to the battery output power limitation, the aircraft's wind resistance and flight performance will be reduced. Please be careful.
3. You need to be extra cautious when flying in low-temperature and high-altitude environments.

## Charging the Battery

- Before using the intelligent flight battery, be sure to fully charge it.
1. Please use a 5V/2A or 5V/3A USB charging plug.
  2. In the charging state, the battery power indicator will flash and indicate the current charge level; when the fourth indicator light is always on, it indicates that the charging is complete.
  3. After charging is complete, please remove the charger in time.

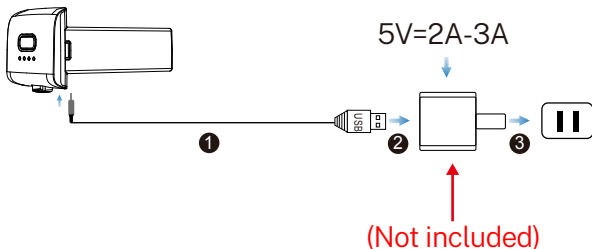



---

**Daily Preservation Advice:**

1. It is recommended to charge and discharge it once a month, do not store with a full charge, keep 50%-60% of the power, the storage temperature is 50°F-104°F(10°C-40°C), and the best storage temperature is 66.2°F-69.8°F(19°C-21°C).
2. If water enters the battery and the battery protection board fails, the battery cannot be used normally. Do not use the battery in rain or in a humid environment, as this may cause the battery to self-ignite or even explode.
3. If the battery is squeezed, deformed and dropped from a high altitude, it is forbidden to use it again.
4. Prolonged exposure to high temperatures is forbidden. High temperatures will cause the internal pressure of the battery to become too high and cause an explosion.
5. The positive and negative poles are short-circuited for a long time (such as the battery contacts have water, short-circuit caused by hair or foreign objects, etc.). If it exceeds 30 minutes, the protection board IC will fail and disconnect, and the battery cannot be used normally.
6. It is forbidden to use fast chargers that exceed the battery's rated power for charging. It is recommended to use a 5V/2A or 5V/3A charger.
7. If the aircraft has not been used for a month, the battery must be removed to prevent the battery from being discharged for a long time.

## 3.8 Camera Overview

- The camera uses an upgraded 5GHz Wi-Fi FPV real-time transmission function, equipped with a 120°FOV lens and a 90°adjustable camera, which can stably shoot 4K HD video and 4K ultra-clear images, providing you with a broad field of vision for unforgettable moments.

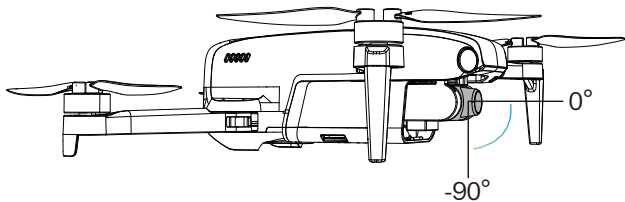

### Storing Photos and Videos

- U11MINI is equipped with a micro SD card slot for storage space expansion.
  - 1.Card speed: 10M/s.
  - 2.File format: support FAT32 format.
  - 3.Memory capacity: a memory card with a memory capacity of 64G or less.
- The mobile phone and the memory card store photos and videos at the same time. If you want clearer videos, please download the video file on the memory card.

Devices	Storage Method		Resolution	Frame Rate
U11MINI	App	Picture	3840×2160P	/
		Video	1280X720P	20fps
	SD card	Picture	3840×2160P	/
		Video	3840×2160P	20fps
			2976×1680P	30fps



1. Check whether the capacity of the memory card is sufficient. If the capacity of the memory card is insufficient, videos and pictures cannot be stored.
2. If you cannot save pictures or videos, try formatting the memory card.
3. After the memory card is installed, the photo and video files will be stored in the memory card, and the photos and videos will not be stored on the mobile phone.
4. You must turn on the aircraft and connect APP to copy or download the photos or videos stored in the aircraft memory card to the phone.
5. Please turn off the aircraft correctly, otherwise the camera parameters will not be saved and the video being recorded will be damaged. Ruko is not responsible for any damage caused by the inability to read videos and photos.

## 4 Remote Controller

### 4.1 Remote Controller Profile

- U11MINI remote controller uses the 5 GHz frequency band, and the remote controller distance is up to 9842FT (unobstructed and interference-free environment). The folding handle can stably place the mobile phone, and the maximum adjustable width is 6.7 inches.
- Remote controller built-in 3000mAh capacity battery, charging time is 4 hours, the longest working time is about 3.3 hours.

### 4.2 Using the Remote Controller

#### Install rocker

- When leaving the factory, the rocker is placed in the packaging bag of the product. When using, the rocker should be installed on the remote control as shown below.

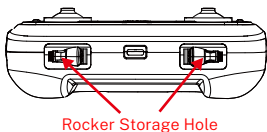

- Unfold the phone clip and install the phone.

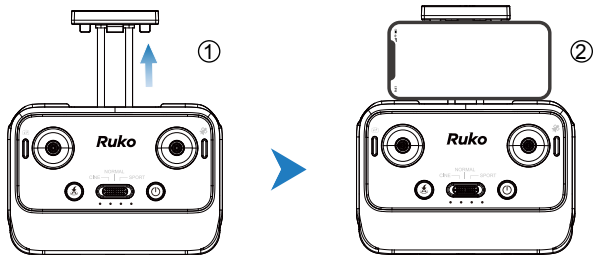

- Connect the phone with remote control via data cable.

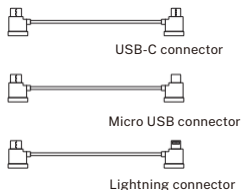
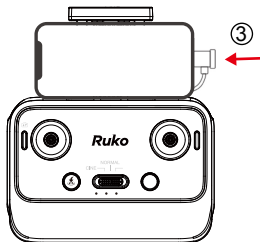

- **Note:** Equipped with 3 different models of data cable, please choose the data cable suitable for your phone to connect.

Please correctly set the USB Settings option that pops up. Select "Transterring tiles" for Android phones, and "Trust" for iPhones. Some USB Settings of Android phones are hidden in the "Developer options" , you need to change the "Default USB configuration" to "Transferring files" after opening the developer mode.

### Powering On/Off

- Turn on the remote control: Press the power button for 3 seconds to turn it on.
- Turn off the remote control: Press the power button for another 3 seconds to turn it off.

## Charging the Controller Battery

- Connect the remote controller Micro USB interface to the charger for charging. Do not use a fast charger that exceeds the rated power. A 5V/2A or 5V/3A charger is recommended.

1. Charging: The four lights flash in turn.
2. Charging is completed: 4 indicators are on.



## Controlling the Camera

1. Photo/Video Button:  
Tap once to take a picture.  
Press and hold 3 seconds to start/stop recording.
2. Gimbal adjustment:  
Turn the gimbal dial to adjust the Angle.  
Quick down or up with one click.

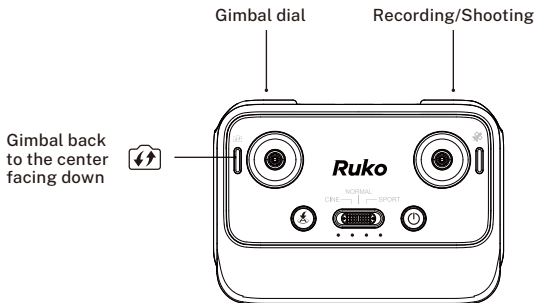

## Joystick Control Aircraft





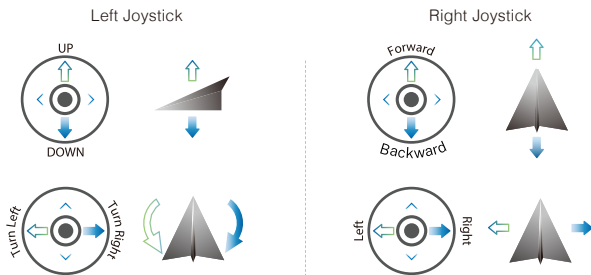

- The control method of the remote controller joystick is as follows:  
American hand's control (Mode 2)

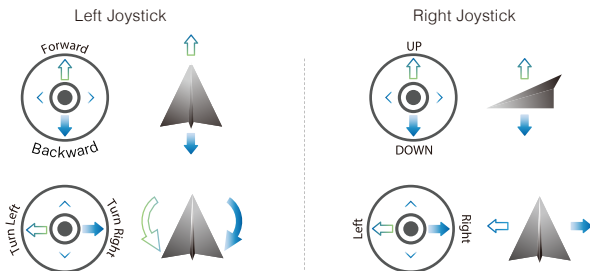
### American hand's control (Mode2)

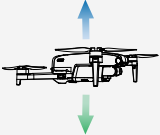

- Switching to Japanese Hand's Control Stick:
  1. Turn on the aircraft.
  2. Press and hold the record button to turn on the power of the remote controller.

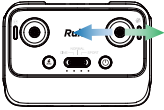

Remote Controller (American hand's control)	Aircraft Direction	Remarks
		<p>Push up/pull down the throttle rocker to control the aircraft up and down. Push the lever up to raise the aircraft. Pull down the lever to lower the aircraft. When released, the joystick is in the middle position and the aircraft remains hovering. When the aircraft takes off, the throttle lever must be pushed upward, and the aircraft will leave the ground and take off (please push the lever slowly to prevent the aircraft from suddenly and rapidly going up).</p>
		<p>Push the throttle lever left/right to control the aircraft's heading. Push the stick to the left, the aircraft rotates counterclockwise. Push the lever to the right, the aircraft rotates clockwise. The rotation angular speed is zero at neutral position, and the aircraft does not rotate. The amount of rocker offset corresponds to the angular speed of flight rotation, the larger the offset, the larger the angular speed of rotation.</p>
		<p>Push up/pull down the directional stick to control the forward and backward flight of the aircraft. Push up the stick to tilt the aircraft forward and fly forward. Pull down the stick, the aircraft tilts backward and flies backward. In neutral position, the forward and backward direction of the aircraft remains horizontal. The amount of rocker offset corresponds to the angle of tilt back and forth, the larger the offset, the larger the angle of tilt, and the faster the flight speed.</p>
		<p>Push left / push right directional stick is used to control the flying machine to fly left and right. Push the stick to the left, the aircraft tilts to the left and flies to the left. When the stick is pushed to the right, the aircraft tilts to the right and flies to the right. In neutral position, the left and right direction of the aircraft remains horizontal. The stick offset corresponds to the angle of the left and right tilt of the aircraft, the larger the offset, the larger the tilt angle, and the faster the flight speed.</p>

- Note: The forward direction of the aircraft is based on the direction of the nose.



## Smart RTH Button

- Tap the smart RTH button on the remote controller, and the aircraft will activate the automatic return function. Tap it again to exit the smart return . The aircraft is hovering in the mid-air of the return. At this time, you can operate the joystick to control the aircraft.

## 4.3 Communication Range of remote controller

- When controlling the aircraft, the position and distance between the remote controller and the aircraft should be adjusted in time, and the antenna position should be adjusted to ensure that the aircraft is always within the best communication range.

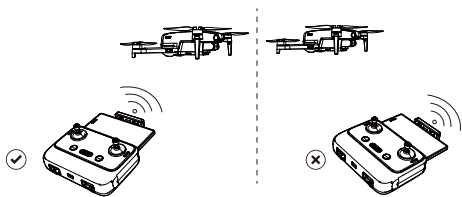

- Install the mobile phone into the remote controller bracket, refer to the aircraft flight direction of the Attitude Indicator in the app, and the attitude Indicator points straight ahead (perpendicular to the coordinates), indicating that the remote controller is facing the aircraft.



## 4.4 Matching the remote controller

- Each time drone flights, it needs to be matched with the remote control. The flight of the drone can be controlled only after the frequency pairing is successful. The steps for the pairing are as follows:
  1. Turn on aircraft.
  2. Turn on remote controller.
  3. The drone and remote control will automatically complete the frequency pair, and the frequency alignment time is about 50 seconds.
  4. Connect the mobile phone with the remote control to enter the APP control interface; The phone displays information such as the power signal of the remote control and the camera screen indicates that the frequency is successfully matched.



- The remote controller pairs with aircraft successfully :
  1. The drone lights will change from red to green,
  2. The green light of the remote control changes from blinking to steady on.



- The drone and the remote control will automatically connect, the connection time is about 50 seconds. Please check the remote control power before each flight. The remote control will sound a tone when the battery is low.
- The remote control will automatically shut down after being idle for 10 minutes, and the remote control can be restored to normal working state by flipping the joystick or pressing any key.
- When using the remote control handle to grip the mobile device, be sure to press tightly to avoid the mobile device slipping.
- Keep the battery at around 3.8-3.9V, and recharge it every month or so to keep the battery active.

## 5 RUKO U11 App

### 5.1 Home

- After running RUKO U11 App, enter the homepage.



#### Control

- Operate the aircraft through the app page buttons to realize the functions of the aircraft.

#### Guide

- Click to view the Help manual, Instructions videos and Quick start.

#### Feedback

- Click to call customer support.

#### Support

- Click to access technical support, after-sales service.