

T-221

3000mA移动电源蓝牙耳机

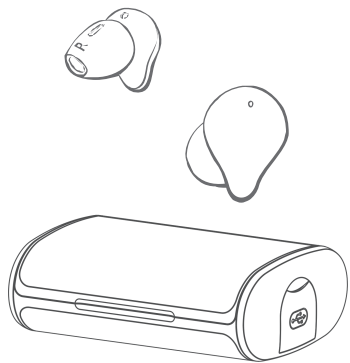

用户手册

简述

感谢您使用本公司蓝牙5.0真无线耳机。本产品具有稳定的连接、清晰的通话质量以及优秀的音乐表现。本产品根据人体工程学设计，佩戴稳固舒适、续航持久；充电盒支持移动电源功能3000mA，可以给其它电子产品充电。

*本公司保留不作任何通知的情况下，对本说明书做内容修改的权利，恕不另行通知。

包装清单

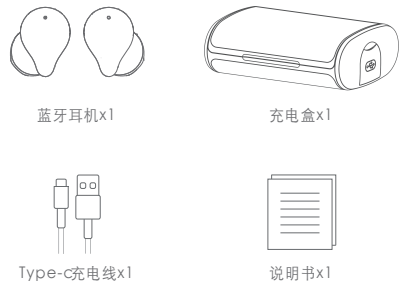

蓝牙耳机x1

充电盒x1

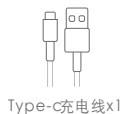

Type-c充电线x1



说明书x1

产品概览

- 1.多功能触摸面板
- 2.磁吸充电触点
- 3.通气孔
- 4.Type-c充电接口
- 5.USB-A充电接口
- 6.电池仓电量显示
- 7.L/R耳机充电状态指示灯

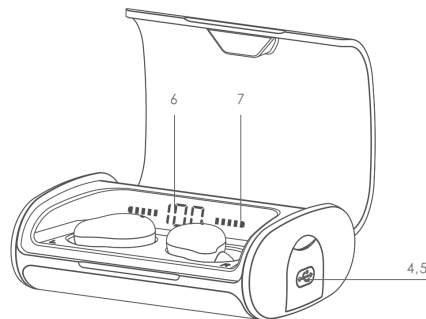
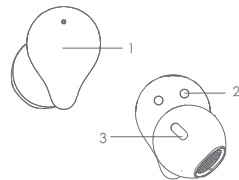

首次使用说明

首次打开包装使用时，请至少充电10分钟。

开盖：耳机自动开机
合盖：耳机关机

蓝牙配对

- 1.从充电盒取出两个耳机；
- 2.两个耳机会自然开机（蓝灯闪烁），然后自动组队，组队好之后主耳机红蓝灯交替闪烁；
- 3.打开手机蓝牙搜索M-21并点击连接。

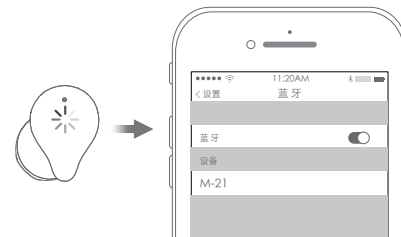

操作方法

	L左耳机	R右耳机
播放/暂停	短按2次(播放中)	短按2次(播放中)
音量+		短按1次
音量-	短按1次	
上一曲	长按2秒	
下一曲		长按2秒
接听/挂断电话	短按1次(通话中)	短按1次(通话中)
拒接电话	长按2秒	长按2秒
语音助手	短按3次	短按3次

指示灯显示状态

耳机充电

开盖状态：耳机放入充电盒中，红灯闪烁，表示正在充电
L耳机充电时，对应电池图案闪烁
R耳机充电时，对应电池图案闪烁



充电盒充电

请通过Type-c接口连接充电线给充电盒充电
请通过USB-A接口连接充电线，可作为充电宝使用给手机等电子产品充电
开盖状态下指示灯显示剩余电量为1%-100%

规格参数

耳机
蓝牙版本：V5.0(EDR)
充电时长：1.5h
使用时间：≈4h
耳机阻抗：32Ω
功率：5mw
频响范围：20Hz-20KHz
灵敏度 (SPL)：104±3dB@1KHz
电池容量：35mA

充电盒
电池容量：350mA
Type-c充电时长：3H
USB充电电流：5V ≈ 1A
电池容量：3000mA

安全规则

- 1.请勿以任何理由拆除或改装耳机，否则可能导致耳机故障及烧毁。
- 2.请勿将设备接触液体弄湿，否则会造成设备严重损坏，由设备进水而造成的损坏，制造商不予保修。
- 3.请勿将设备长时间放置于温度过高或过低(75度以上或零下40度以下)的环境下。
- 4.请避免靠近儿童或动物的眼睛使用设备指示灯。
- 5.请勿在雷雨天气下使用该设备，雷暴可导致设备工作不正常，并增加触电危险。
- 6.废弃时不要将此电子设备作为普通垃圾处理，为减少污染和在最大程度上保护地球的环境，请将其利用回收。

常见问题及其解决方法

故障现象	故障原因	解决方法
不能开机/耳机自动关闭	电池电量不足	对耳机进行充电2-5小时
配对后无声	配对不正确	重新配对
可以通话，但亮红指示灯	电池电量不足 出现红灯提示	请立即对耳机进行充电
充电无指示	充电器无电压输出	检查充电器是否插好 或电源开关是否打开
耳机有回音	音量过大或 环境过于嘈杂	调节音量或换一个场所
通话有杂音	环境干扰造成或耳机 与设备距离过远	换一个场所或将耳机 与设备的距离拉近
双方声音小	耳机佩戴不正确	调整耳机的位置
无法收听音乐	手机不支持	换支持立体声的蓝牙耳机

保修卡

尊敬的用户，本保修卡是申请保修服务的正要凭证，请您配合销售商填写并妥善保管，谢谢！

用户信息	用户姓名	电子邮件	
	联系电话	邮政编码	
	通讯地址		
产品信息	产品名称	产品条码/ 编码/批号	
	产品型号		
销售商信息	名称	邮政编码	
	联系电话	发票号码	
	销售日期		
	地址		
备注			

T-221

Bluetooth 5.0
3000mA Powerbank Bluetooth earbuds

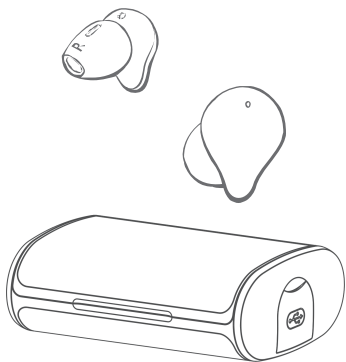

User Manual

Brief

Thank you for using our Bluetooth 5.0 true wireless headset. It has stable connection, clear call quality and excellent performance. It is stable, comfortable and durable according to the ergonomic design; Charging box support powerbank function 3000mA, can charge other electric products.

*Our company reserves the right to modify the contents of this instructions without notice.

Packing list

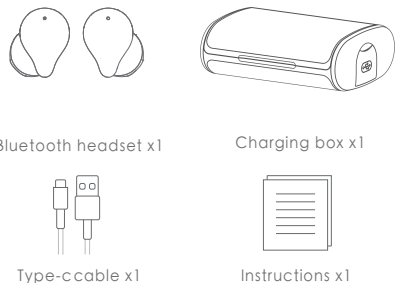

Bluetooth headset x1

Charging box x1

Type-c cable x1

Instructions x1

Product information

1. Multifunctional touch panel
2. Magnetic charging touch point
3. Spiracle
4. Type-c charging interface
5. USB-A charging interface
6. Charging box electric power indicator
7. L/R headset charging status indicator light

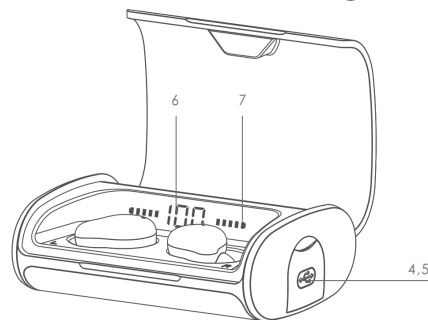
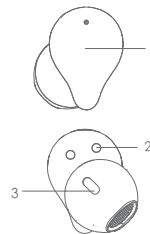

Instructions for first using

When opening the package for use for the first time, please charge for at least 10 minutes.

When opening the package for use for the first time, please charge for at least 10 minutes.

When opening the package for use for the first time, please charge for at least 10 minutes.

Bluetooth pairing

1. Take out two headsets from the charging box;
2. Two headsets will turn on naturally (blue light flashes), and then automatically form a team. After the team is formed the red and blue lights of the main headset flash alternately.
3. Turn on Bluetooth search M-21 on your phone and click Connect

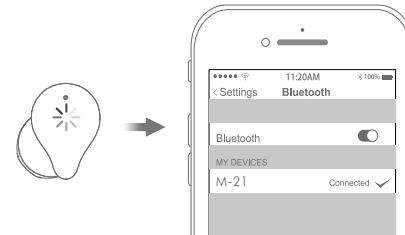

Operation method

	L left headset	R right headset
Play/pause	Short press twice (in play)	Short press twice (in play)
Volume+		Short press 1 time
Volume-	Short press 1 time	
Backward	Long press for 2 seconds	
Forward		Long press for 2 seconds
Answer / end a call	Short press 1 time (during call)	Short press 1 time (during call)
Refuse to answer a call	Long press for 2 seconds	Long press for 2 seconds
Voice assistant	Short press 3 times	Short press 3 times

Indicator light shows status

Earphone charging

Cover opening status: When the headset is put into the charging box, and the red light flashes, indicating that it is charging.

When L headset is charging, corresponding red light flashes.

When R headset is charging, corresponding red light flashes.



Charging by charging box

Please connect charging cable through Type-C interface to charging box.

Please connect charging cable through USB-A interface, can use powerbank to charge for mobile phone electric product etc. Cover opening status the indicator light shows that the remaining power is 1%~100%.

Specifications

Headset
Bluetooth version: V5.0 (EDR)
Charging time: 1.5 hours
Using time: ≈ 4h
Headset impedance: 32Ω
Capacity: 5mw
Frequency range: 20Hz-20KHz
Sensitivity (SPL): 104±3dB@1KHz
Battery capacity 35mA

Charging Box
Battery capacity: 350mA
Type-C charging time: 3 hours
USB charging electric current: 5V=1A
Charging box battery capacity: 3000mA

Safety rules

1. Do not remove or refit headset for any reason, otherwise it may cause headset fault and burning.
2. Do not wet the device in contact with liquid, otherwise it will cause serious damage to the device. The manufacturer will not guarantee the damage caused by water inflow of the device.
3. Do not place the device in the environment with too high or too low temperature (above 75 °C or below -40 °C) for a long time.
4. Please avoid using the device indicator light near the eyes of children or animals.
5. Do not use the device in thunderstorm weather. Thunderstorm may cause abnormal operation of the device and increase the risk of electric shock.
6. Do not treat this electronic device as ordinary garbage when it is discarded. In order to reduce pollution and protect the environment to the greatest extent, please recycle it.

Common problems and Solutions

Fault phenomenon	Fault reason	Solutions
Unable to turn on / off	The battery is power off	Charge the headset for 2-5 hours
No sound after pairing	Incorrect pairing	Repeating
Can make phone call, but the red light is on	Low battery Red light prompt appears	Please charge the headset at once
Charging without indication	Charger no voltage output	Check whether the charger is plugged in properly or whether the power switch is on
The headset has an echo	Excessive volume The environment is too noisy	Adjust the volume or change the place
There is noise in the call	Environmental interference or Headset is too far away from the device	Change a place or close the distance between headset and device
The volume is too low for both side	Headset incorrect wearing	Adjust the position of the headset
Unable to listen to music	Phone unsupported	Change to Bluetooth phone with stereo support

Guarantee

Dear users, this Guarantee is the voucher for applying for warranty service. Please cooperate with the seller to fill in and keep it properly. Thank you!

Users information	User name		Email address	
	Contact number		Post code	
	Address			
Production information	Product name		Product barcode / Code / batch No.	
	Product model			
Dealers information	Name		Post code	
	Contact number		Invoice number	
	Sale date			
	Address			
Remarks				

This device complies with part 15 of the FCC Rules. Operation is subject to the following two conditions: (1) This device may not cause harmful interference, and (2) this device must accept any interference received, including interference that may cause undesired operation.

Any Changes or modifications not expressly approved by the party responsible for compliance could void the user's authority to operate the equipment.

Note: This equipment has been tested and found to comply with the limits for a Class B digital device, pursuant to part 15 of the FCC Rules. These limits are designed to provide reasonable protection against harmful interference in a residential installation. This equipment generates uses and can radiate radio frequency energy and, if not installed and used in accordance with the instructions, may cause harmful interference to radio communications. However, there is no guarantee that interference will not occur in a particular installation. If this equipment does cause harmful interference to radio or television reception, which can be determined by turning the equipment off and on, the user is encouraged to try to correct the interference by one or more of the following measures:

- Reorient or relocate the receiving antenna.
- Increase the separation between the equipment and receiver.
- Connect the equipment into an outlet on a circuit different from that to which the receiver is connected.
- Consult the dealer or an experienced radio/TV technician for help.