

# 3D Antenna Measurement Summary Report

**REPORT NO.:** OR-W7L-P20120005

**PLATFORM  
MANUFACTURER:** Dongguan Chuand Electronics Technology Co., Ltd.

**PLATFORM NAME:** Dongle

**ANTENNA TYPE:** Onboard Antenna

**TESTED DATE:** 2020.12.09

**ISSUED:** 2020.12.11

**APPLICANT:** Dongguan Chuand Electronics Technology Co., Ltd.

**ADDRESS :** Xihe Industrial Area, Shijie Town, Dongguan City,  
Guangdong Province, China

**SSUED BY :** BV 7Layers Communications Technology (Shenzhen)  
Co. Ltd.

**ADDRESS :** No. B102, Dazu Chuangxin Mansion, North of Beihuan  
Avenue, North Area, Hi-Tech Industry Park, Nanshan  
District, Shenzhen, Guangdong, China

This report is for your exclusive use. Any copying or replication of this report to or for any other person or entity, or use of our name or trademark, is permitted only with our prior written permission. This report sets forth our findings solely with respect to the test samples identified herein. The results set forth in this report are not indicative or representative of the quality or characteristics of the lot from which a test sample was taken or any similar or identical product unless specifically and expressly noted. Our report includes all of the tests requested by you and the results thereof based upon the information that you provided to us. You have 60 days from date of issuance of this report to notify us of any material error or omission caused by our negligence, provided, however, that such notice shall be in writing and shall specifically address the issue you wish to raise. A failure to raise such issue within the prescribed time shall constitute your unqualified acceptance of the completeness of this report, the tests conducted and the correctness of the report contents. Unless specific mention, the uncertainty of measurement has been explicitly taken into account to declare the compliance or non-compliance to the specification

## RELEASE CONTROL RECORD

REPORT NO.	REASON FOR CHANGE	DATE ISSUED
OR-W7L-P20120005	Original release	2020.12.11

### Table of Contents

GENERAL INFORMATION.....	3
1. Test Equipment List.....	4
2. Measurement Uncertainty.....	4
3. Characteristics of antenna .....	5
4. Antenna Pattern .....	7
Appendix A. Testing Setup Photo.....	10

## GENERAL INFORMATION

<b>APPLICANT:</b>	Dongguan Chuand Electronics Technology Co., Ltd.
<b>MANUFACTURER:</b>	Dongguan Chuand Electronics Technology Co., Ltd.
<b>MODEL NO.:</b>	Dongle Antenna

Test Standard: ANSI/IEEE Std. 149 1979.

PREPARED BY : Li Bo , DATE : 2020.12.11  
Li Bo / Engineer

APPROVED BY : Luke Lu , DATE : 2020.12.11  
Luke Lu / Manager

## 1. Test Equipment List

TYPE OF EQUIPMENT	MODEL NUMBER	SERIAL NUMBER	CALIBRATION DUE DATE
Network Analyzer	E5071C	MY46214638	2021.06.02
OTA Chamber	ETS AMS8500	N/A	N/A
RF Switch	ETS EMCenter	N/A	N/A
Measurement Antenna	ETS 3165-01	N/A	N/A

## 2. Measurement Uncertainty

Expanded Uncertainty for Measurement (k=2 or 95% Confidence Level) at Passive antenna test over frequency range 780 – 2200MHz is +/- 1.52 dB.

### 3. Characteristics of antenna

#### 3.1. S11-VSWR

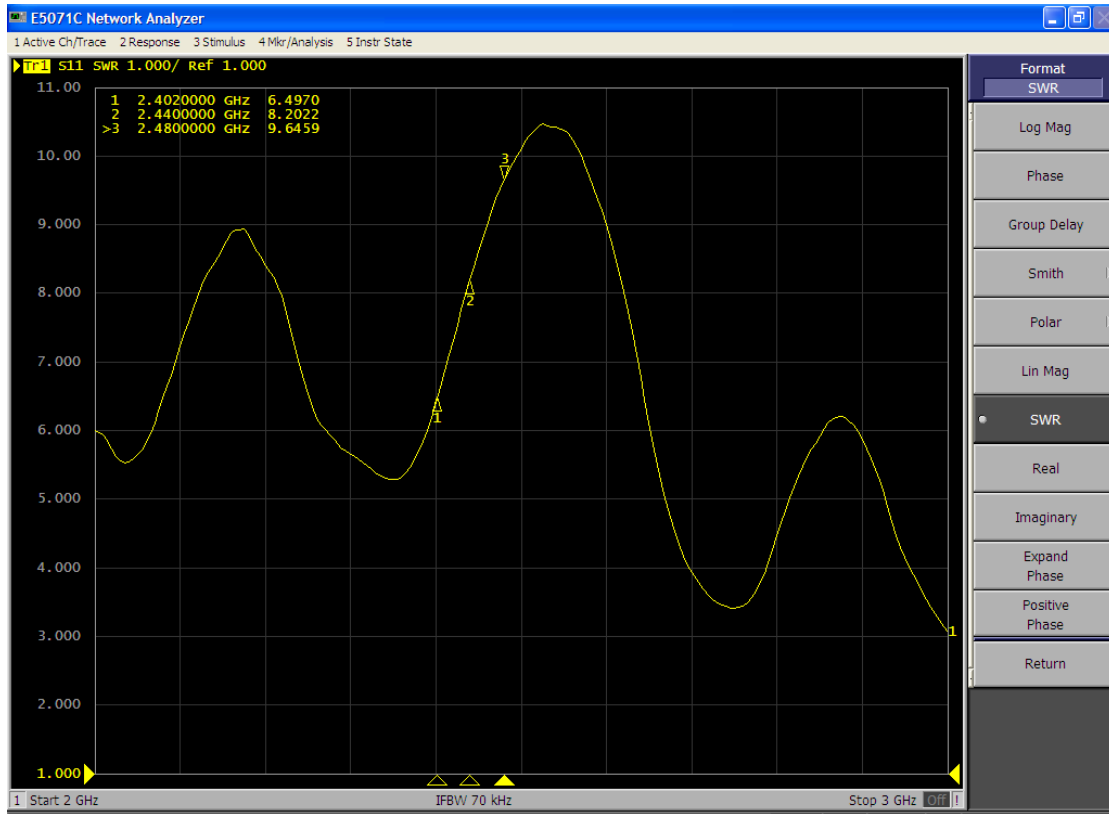

#### 3.2. S11-ReturnLoss

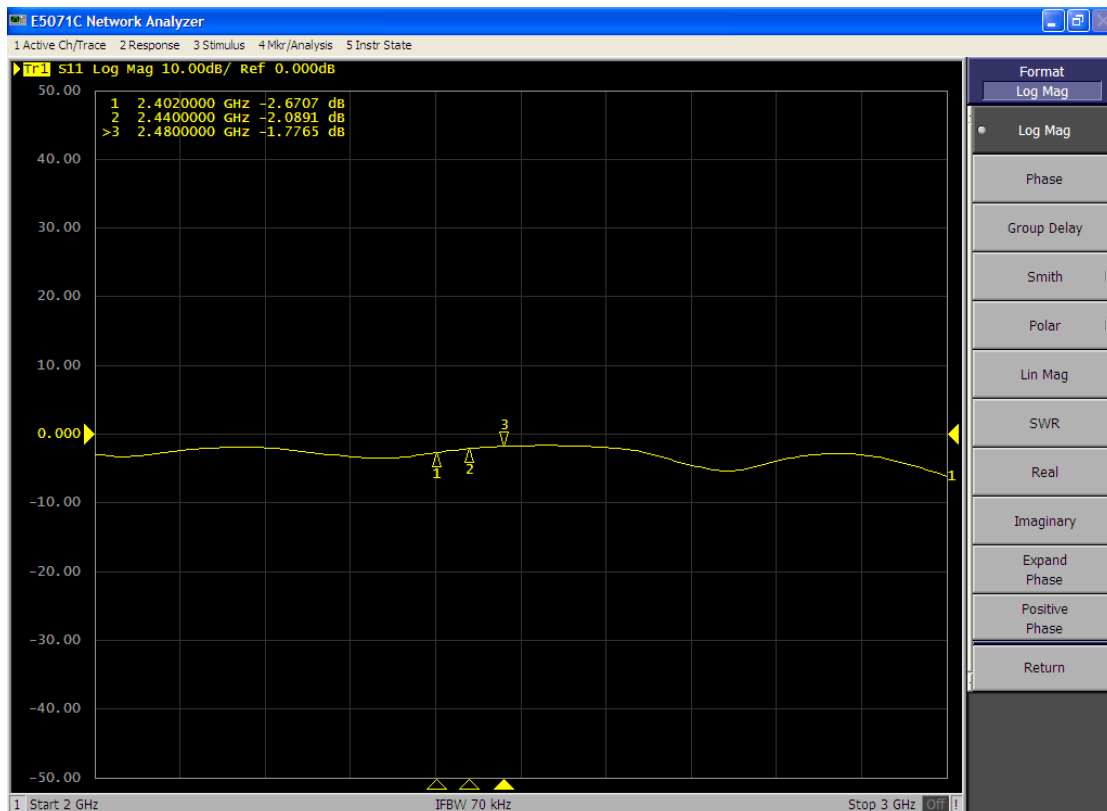



### 3.3. 3D Antenna Gain-Free Space

Frequency (MHz)	Directivity (dBi)	Efficiency (dB)	Efficiency (%)	Gain (dBi)
2402	8.10	-8.87	12.97	-0.77
2404	8.11	-8.86	13.01	-0.75
2406	8.11	-8.88	12.96	-0.76
2408	8.10	-8.91	12.84	-0.81
2410	8.10	-8.91	12.86	-0.80
2412	8.12	-8.94	12.76	-0.83
2414	8.16	-8.92	12.83	-0.76
2416	8.15	-8.96	12.70	-0.82
2418	8.13	-9.02	12.53	-0.89
2420	8.15	-9.04	12.46	-0.90
2422	8.14	-9.09	12.32	-0.95
2424	8.17	-9.18	12.08	-1.01
2426	8.17	-9.18	12.08	-1.01
2428	8.16	-9.22	11.98	-1.05
2430	8.16	-9.34	11.65	-1.18
2432	8.13	-9.35	11.62	-1.21
2434	8.15	-9.42	11.44	-1.26
2436	8.13	-9.55	11.09	-1.42
2438	8.16	-9.55	11.09	-1.39
2440	8.18	-9.60	10.97	-1.41
2442	8.17	-9.73	10.65	-1.56
2444	8.19	-9.69	10.73	-1.50
2446	8.21	-9.77	10.55	-1.56
2448	8.21	-9.83	10.40	-1.62
2450	8.21	-9.87	10.30	-1.66
2452	8.17	-9.94	10.15	-1.77
2454	8.20	-9.91	10.21	-1.71
2456	8.21	-9.94	10.14	-1.73
2458	8.26	-9.98	10.04	-1.72
2460	8.21	-10.07	9.83	-1.86
2462	8.20	-10.15	9.66	-1.95
2464	8.18	-10.23	9.49	-2.04
2466	8.21	-10.28	9.37	-2.07
2468	8.20	-10.25	9.44	-2.05
2470	8.23	-10.24	9.47	-2.01
2472	8.24	-10.23	9.48	-1.99
2474	8.24	-10.23	9.49	-1.99
2476	8.23	-10.20	9.54	-1.98
2478	8.25	-10.21	9.53	-1.95
2480	8.25	-10.23	9.48	-1.98

# Antenna Pattern

2402MHz  
Total

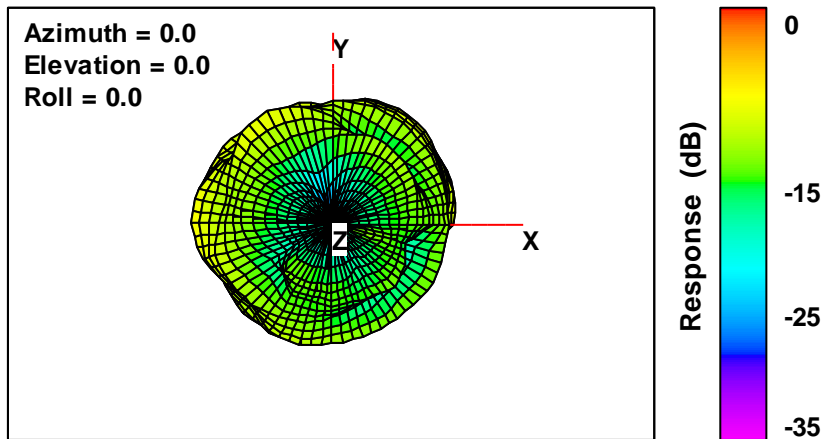

Total

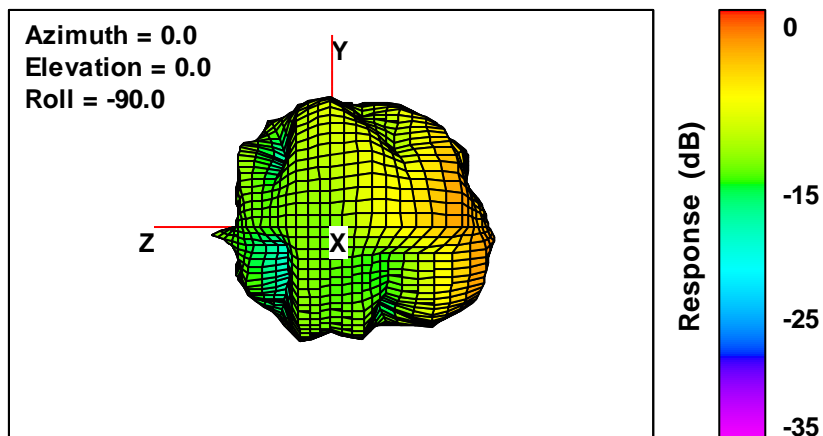

Total

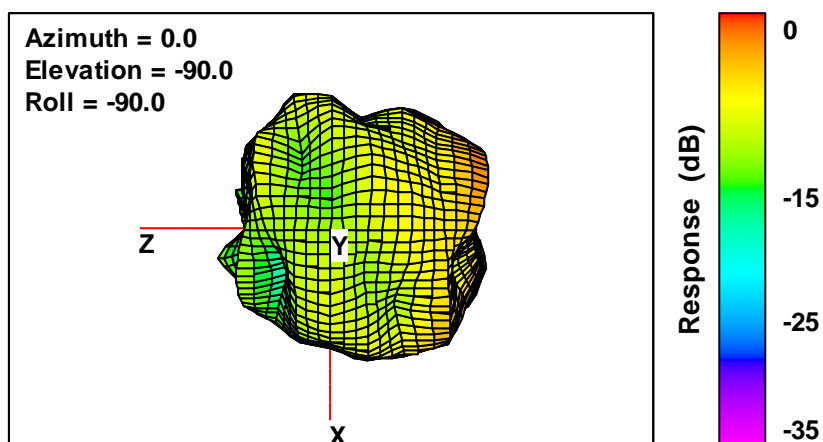

2440MHz

Total

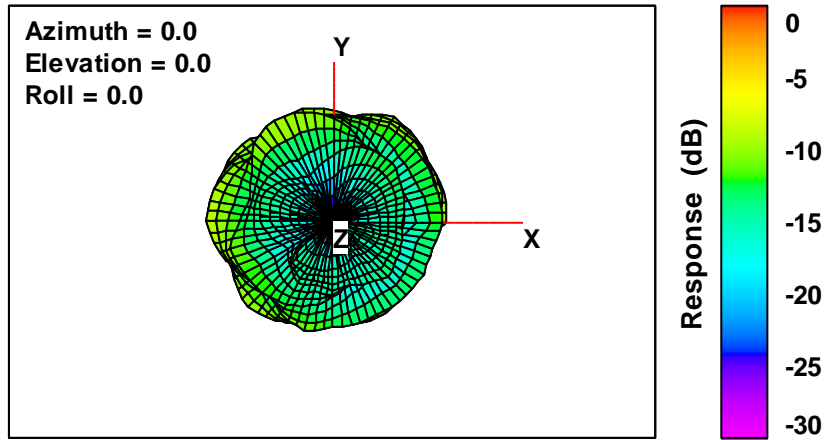

Total

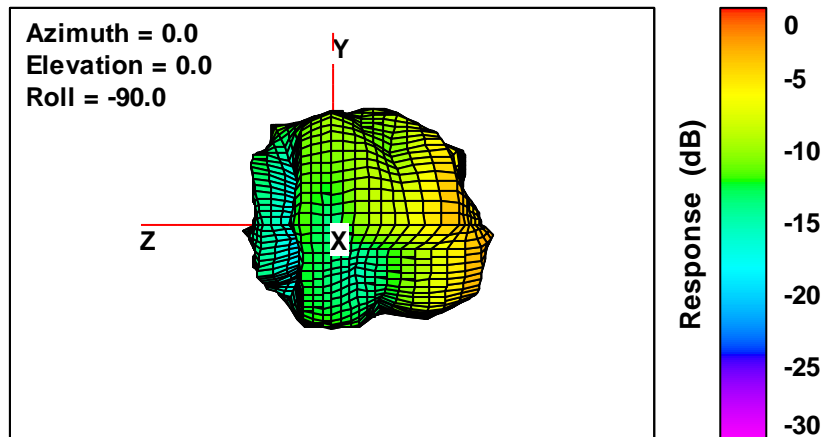

Total

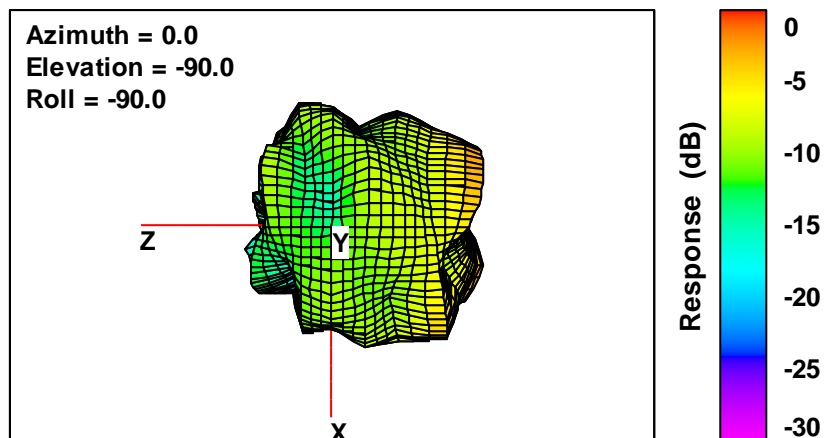



2480MHz

Total

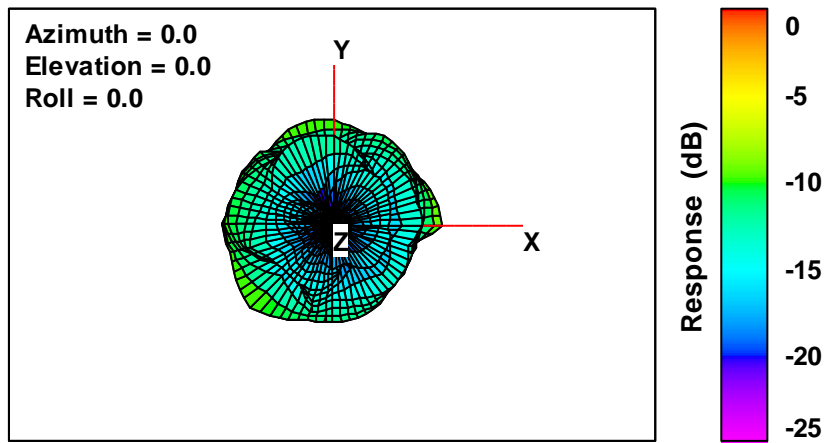

Total

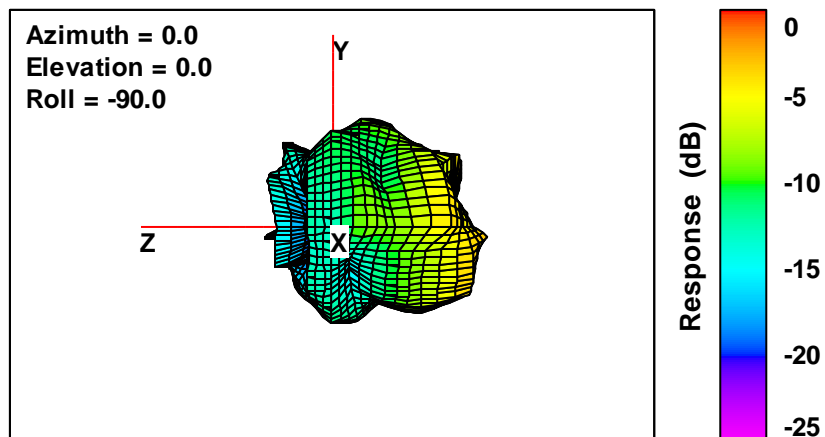

Total

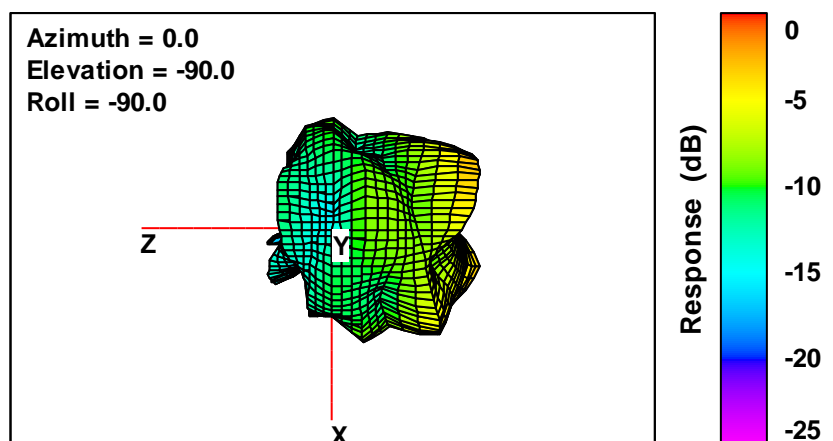

c

### Appendix A. Testing Setup Photo



Free Space

