



TESTING LABORATORY  
CERTIFICATE#4323.01



FCC PART 15.407(H)  
DYNAMIC FREQUENCY SELECTION  
TEST REPORT

For

**Beijing Wiseasy Technology CO., Ltd.**

7th Floor, Block B, Wangxin Mansion, No.28 Xiaoyun Road, Chaoyang District, 100027,  
Beijing, China

**FCC ID: 2AXOJ-WPOS-3**

<b>Report Type:</b> Original Report	<b>Product Type:</b> WPOS Intelligent Business Terminal
<b>Project Engineer:</b>	Jack Jiao <i>Jack Jiao</i>
<b>Report Number:</b>	RKSA200927001-00F
<b>Report Date:</b>	2020-12-02
<b>Reviewed By:</b>	Oscar Ye EMC Manager <i>Oscar Ye</i>
<b>Test Laboratory:</b>	Bay Area Compliance Laboratories Corp. (Kunshan) No.248 Chenghu Road, Kunshan, Jiangsu province, China Tel: +86-0512-86175000 Fax: +86-0512-88934268 <a href="http://www.baclcorp.com.cn">www.baclcorp.com.cn</a>

## TABLE OF CONTENTS

<b>GENERAL INFORMATION.....</b>	<b>3</b>
PRODUCT DESCRIPTION FOR EQUIPMENT UNDER TEST (EUT).....	3
OBJECTIVE.....	3
RELATED SUBMITTAL(S)/GRANT(S).....	3
TEST METHODOLOGY.....	3
TEST FACILITY.....	4
<b>SYSTEM TEST CONFIGURATION.....</b>	<b>5</b>
DESCRIPTION OF TEST CONFIGURATION.....	5
EUT EXERCISE SOFTWARE.....	5
EQUIPMENT MODIFICATIONS.....	5
SUPPORT EQUIPMENT LIST AND DETAILS.....	5
EXTERNAL I/O CABLE.....	5
<b>SUMMARY OF TEST RESULTS.....</b>	<b>6</b>
<b>TEST EQUIPMENT LIST.....</b>	<b>7</b>
<b>APPLICABLE STANDARDS.....</b>	<b>8</b>
DFS REQUIREMENT.....	8
DFS MEASUREMENT SYSTEM.....	12
SYSTEM BLOCK DIAGRAM.....	12
4.5 RADIATED METHOD.....	14
4.6 TEST PROCEDURE.....	14
<b>TEST RESULTS.....</b>	<b>15</b>
DESCRIPTION OF EUT.....	15
TEST ENVIRONMENTAL CONDITIONS.....	15
<b>CHANNEL MOVE TIME AND CHANNEL CLOSING TRANSMISSION TIME.....</b>	<b>17</b>
TEST PROCEDURE.....	17
TEST RESULTS.....	17
<b>NON-OCCUPANCY PERIOD.....</b>	<b>20</b>
TEST PROCEDURE.....	20
TEST RESULT.....	20

## GENERAL INFORMATION

### Product Description for Equipment under Test (EUT)

Applicant	Beijing Wiseasy Technology CO., Ltd.
Tested Model	WPOS-3
Product Type	WPOS Intelligent Business Terminal
Power Supply	DC 5.0V from adapter and DC 3.7V from battery
Antenna Type	FPC Antenna
*Maximum Antenna Gain	1.0 dBi

*Adapter Information:*

*Model: ASSA107a-050200*

*Input: AC 100-240V, 50/60Hz, 0.45A*

*Output: DC 5.0V, 2.0A*

*Note: The antenna gain was provided by the applicant.*

*\*All measurement and test data in this report was gathered from production sample serial number: 20200927001. (Assigned by the BACL. The EUT supplied by the applicant was received on 2020-09-27)*

### Objective

This report is prepared on behalf of *Beijing Wiseasy Technology CO., Ltd.* in accordance with FCC CFR47 §15.407 (h), Dynamic Frequency Selection (DFS) for devices operating in the bands 5250- 5350 MHz and 5470-5725 MHz.

### Related Submittal(s)/Grant(s)

FCC Part 15.247 DSS Submittal with FCC ID: 2AXOJ-WPOS-3

FCC Part 15.247 DTS Submittal with FCC ID: 2AXOJ-WPOS-3

FCC Part 15.225 DXX submissions with FCC ID: 2AXOJ-WPOS-3

FCC Part 22H24E27 PCB submissions with FCC ID: 2AXOJ-WPOS-3

### Test Methodology

FCC CFR 47 Part2, Part15.407 (h)

KDB 905462 D02 UNII DFS Compliance Procedures New Rules v02

905462 D03 Client Without DFS New Rules v01r02

### **Test Facility**

The Test site used by Bay Area Compliance Laboratories Corp. (Kunshan) to collect test data is located on the No.248 Chenghu Road, Kunshan, Jiangsu province, China.

Bay Area Compliance Laboratories Corp. (Kunshan) Lab is accredited to ISO/IEC 17025 by A2LA (Lab code: 4323.01), the FCC designation No. CN1185 under the FCC KDB 974614 D01 and CAB identifier CN0004 under the ISED requirement. The facility also complies with the radiated and AC line conducted test site criteria set forth in ANSI C63.4-2014.

## SYSTEM TEST CONFIGURATION

---

### Description of Test Configuration

The EUT was configured for testing in an engineering mode which was provided by the manufacturer.

### EUT Exercise Software

No exercise software was used.

### Equipment Modifications

N/A

### Support Equipment List and Details

Manufacturer	Description	Model	Serial Number
DELL	Notebook	GX620	D65874152
RUCKUS	Access Point	T300	211404000213

### External I/O Cable

Cable Description	Length (m)	From Port	To
Power Cable	1.0	Baseplate1	Adapter
RJ45 Cable	1.0	Access Point	Notebook

**SUMMARY OF TEST RESULTS**

The following result table represents the list of measurements required under the CFR47 §47 Part15.407 (h), FCC KDB 905462 D02 UNII DFS Compliance Procedures New Rules v02

Items	Description of Test	Result
Detection Bandwidth	UNII Detection Bandwidth	Not applicable
Performance Requirements Check	Initial Channel Availability Check Time (CAC)	Not applicable
	Radar Burst at the Beginning of the CAC	Not applicable
	Radar Burst at the End of the CAC	Not applicable
In-Service Monitoring	Channel Move Time	Compliant
	Channel Closing Transmission Time	Compliant
	Non-Occupancy Period	Compliant
Radar Detection	Statistical Performance Check	Not applicable

Note:

1) Not applicable: the EUT is a client unit without radar detection.

**TEST EQUIPMENT LIST**

Manufacturer	Description	Model	Serial Number	Calibration Date	Calibration Due Date
<b>RF Conducted Test</b>					
Rohde & Schwarz	FSV40 Signal Analyzer	FSV40	101116	2020-07-28	2021-07-27
Rohde & Schwarz	SMBV100A Vector Signal Generator	SMBV100A	261558	2020-07-28	2021-07-27
HP	Attenuator/11dB	8494B	N/A	2020-01-10	2021-01-09
Agilent	Attenuator/110dB	8496B	N/A	2020-01-10	2021-01-09
Beijing Wiseasy	RF Cable	Beijing Wiseasy C01	C01	Each Time	/

\* **Statement of Traceability:** Bay Area Compliance Laboratories Corp. (Kunshan) attests that all calibrations have been performed in accordance to requirements that traceable to National Primary Standards and International System of Units (SI).

**APPLICABLE STANDARDS**

**DFS Requirement**

CFR §47 Part 15.407(h)

FCC KDB 905462 D02 UNII DFS Compliance Procedures New Rules D02 v02

**Table 1: Applicability of DFS Requirements Prior to Use of a Channel**

Requirement	Operational Mode		
	Master	Client Without Radar Detection	Client With Radar Detection
<i>Non-Occupancy Period</i>	Yes	Not required	Yes
<i>DFS Detection Threshold</i>	Yes	Not required	Yes
<i>Channel Availability Check Time</i>	Yes	Not required	Not required
<i>U-NII Detection Bandwidth</i>	Yes	Not required	Yes

**Table 2: Applicability of DFS requirements during normal operation**

Requirement	Operational Mode	
	Master Device or Client with Radar Detection	Client Without Radar Detection
<i>DFS Detection Threshold</i>	Yes	Not required
<i>Channel Closing Transmission Time</i>	Yes	Yes
<i>Channel Move Time</i>	Yes	Yes
<i>U-NII Detection Bandwidth</i>	Yes	Not required

Additional requirements for devices with multiple bandwidth modes	Master Device or Client with Radar Detection	Client Without Radar Detection
<i>U-NII Detection Bandwidth and Statistical Performance Check</i>	All BW modes must be tested	Not required
<i>Channel Move Time and Channel Closing Transmission Time</i>	Test using widest BW mode available	Test using the widest BW mode available for the link
<i>All other tests</i>	Any single BW mode	Not required
<b>Note:</b> Frequencies selected for statistical performance check (Section 7.8.4) should include several frequencies within the radar detection bandwidth and frequencies near the edge of the radar detection bandwidth. For 802.11 devices it is suggested to select frequencies in each of the bonded 20 MHz channels and the channel center frequency.		



**Table 3: DFS Detection Thresholds for Master Devices and Client Devices With Radar Detection**

Maximum Transmit Power	Value (See Notes 1, 2, and 3)
EIRP ≥ 200 milliwatt	-64 dBm
EIRP < 200 milliwatt and power spectral density < 10 dBm/MHz	-62 dBm
EIRP < 200 milliwatt that do not meet the power spectral density requirement	-64 dBm
<p><b>Note 1:</b> This is the level at the input of the receiver assuming a 0 dBi receive antenna.</p> <p><b>Note 2:</b> Throughout these test procedures an additional 1 dB has been added to the amplitude of the test transmission waveforms to account for variations in measurement equipment. This will ensure that the test signal is at or above the detection threshold level to trigger a DFS response.</p> <p><b>Note3:</b> EIRP is based on the highest antenna gain. For MIMO devices refer to KDB Publication 662911 D01.</p>	

**Table 4: DFS Response Requirement Values**

Parameter	Value
<i>Non-occupancy period</i>	Minimum 30 minutes
<i>Channel Availability Check Time</i>	60 seconds
<i>Channel Move Time</i>	10 seconds See Note 1.
<i>Channel Closing Transmission Time</i>	200 milliseconds + an aggregate of 60 milliseconds over remaining 10 second period. See Notes 1 and 2.
<i>U-NII Detection Bandwidth</i>	Minimum 100% of the U-NII 99% transmission power bandwidth. See Note 3.
<p><b>Note 1:</b> <i>Channel Move Time</i> and the <i>Channel Closing Transmission Time</i> should be performed with Radar Type 0. The measurement timing begins at the end of the Radar Type 0 burst.</p> <p><b>Note 2:</b> The <i>Channel Closing Transmission Time</i> is comprised of 200 milliseconds starting at the beginning of the <i>Channel Move Time</i> plus any additional intermittent control signals required to facilitate a <i>Channel</i> move (an aggregate of 60 milliseconds) during the remainder of the 10 second period. The aggregate duration of control signals will not count quiet periods in between transmissions.</p> <p><b>Note 3:</b> During the <i>U-NII Detection Bandwidth</i> detection test, radar type 0 should be used. For each frequency step the minimum percentage of detection is 90 percent. Measurements are performed with no data traffic.</p>	

**Table 5 – Short Pulse Radar Test Waveforms**

Radar Type	Pulse Width (μsec)	PRI (μsec)	Number of Pulses	Minimum Percentage of Successful Detection	Minimum Number of Trials
0	1	1428	18	See Note 1	See Note 1
1	1	Test A: 15 unique PRI values randomly selected from the list of 23 PRI values in Table 5a	Roundup $\left\{ \left( \frac{1}{360} \right) \cdot \left( \frac{19 \cdot 10^6}{\text{PRI}_{\mu\text{sec}}} \right) \right\}$	60%	30
		Test B: 15 unique PRI values randomly selected within the range of 518-3066 μsec, with a minimum increment of 1 μsec, excluding PRI values selected in Test A			
2	1-5	150-230	23-29	60%	30
3	6-10	200-500	16-18	60%	30
4	11-20	200-500	12-16	60%	30
Aggregate (Radar Types 1-4)				80%	120
<b>Note 1:</b> Short Pulse Radar Type 0 should be used for the detection bandwidth test, channel move time, and channel closing time tests.					

A minimum of 30 unique waveforms are required for each of the Short Pulse Radar Types 2 through 4. If more than 30 waveforms are used for Short Pulse Radar Types 2 through 4, then each additional waveform must also be unique and not repeated from the previous waveforms. If more than 30 waveforms are used for Short Pulse Radar Type 1, then each additional waveform is generated with Test B and must also be unique and not repeated from the previous waveforms in Tests A or B.

For example if in Short Pulse Radar Type 1 Test B a PRI of 3066 usec is selected, the number of pulses

would be  $\text{Roundup} \left\{ \left( \frac{1}{360} \right) \cdot \left( \frac{19 \cdot 10^6}{3066} \right) \right\} = \text{Roundup} \{17.2\} = 18.$

**Table 5a - Pulse Repetition Intervals Values for Test A**

<b>Pulse Repetition Frequency Number</b>	<b>Pulse Repetition Frequency (Pulses Per Second)</b>	<b>Pulse Repetition Interval (Microseconds)</b>
1	1930.5	518
2	1858.7	538
3	1792.1	558
4	1730.1	578
5	1672.2	598
6	1618.1	618
7	1567.4	638
8	1519.8	658
9	1474.9	678
10	1432.7	698
11	1392.8	718
12	1355	738
13	1319.3	758
14	1285.3	778
15	1253.1	798
16	1222.5	818
17	1193.3	838
18	1165.6	858
19	1139	878
20	1113.6	898
21	1089.3	918
22	1066.1	938
23	326.2	3066

The aggregate is the average of the percentage of successful detections of Short Pulse Radar Types 1-4. For example, the following table indicates how to compute the aggregate of percentage of successful detections.

<b>Radar Type</b>	<b>Number of Trials</b>	<b>Number of Successful Detections</b>	<b>Minimum Percentage of Successful Detection</b>
1	35	29	82.9%
2	30	18	60%
3	30	27	90%
4	50	44	88%
<b>Aggregate (82.9% + 60% + 90% + 88%)/4 = 80.2%</b>			

**Table 6 – Long Pulse Radar Test Waveform**

Radar Type	Pulse Width (μsec)	Chirp Width (MHz)	PRI (μsec)	Number of Pulses per <i>Burst</i>	Number of <i>Bursts</i>	Minimum Percentage of Successful Detection	Minimum Number of Trials
5	50-100	5-20	1000-2000	1-3	8-20	80%	30

**Table 7 – Frequency Hopping Radar Test Waveform**

Radar Type	Pulse Width (μsec)	PRI (μsec)	Pulses per Hop	Hopping Rate (kHz)	Hopping Sequence Length (msec)	Minimum Percentage of Successful Detection	Minimum Number of Trials
6	1	333	9	0.333	300	70%	30

**DFS Measurement System**

BACL DFS measurement system consists of two subsystems: (1) The radar signal generating subsystem and (2) the traffic monitoring subsystem.

**System Block Diagram**

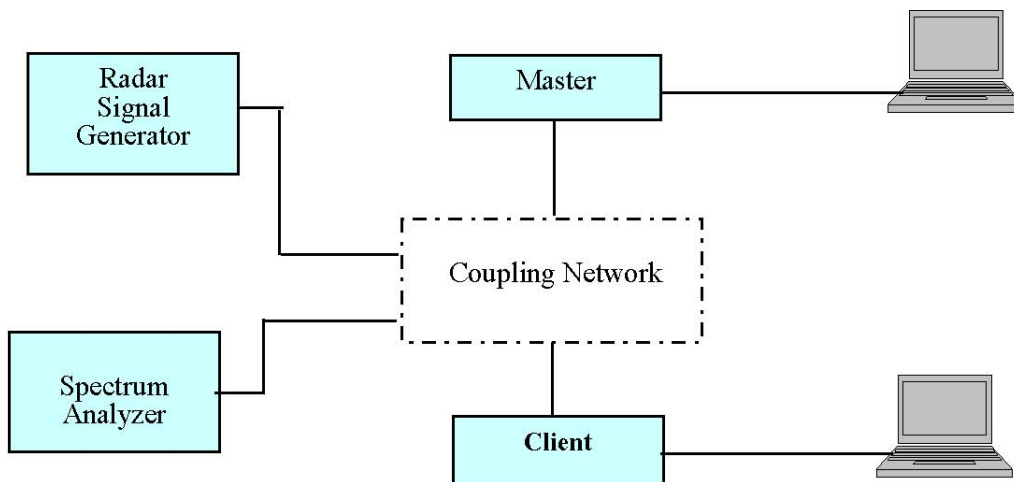

**Conducted Method**

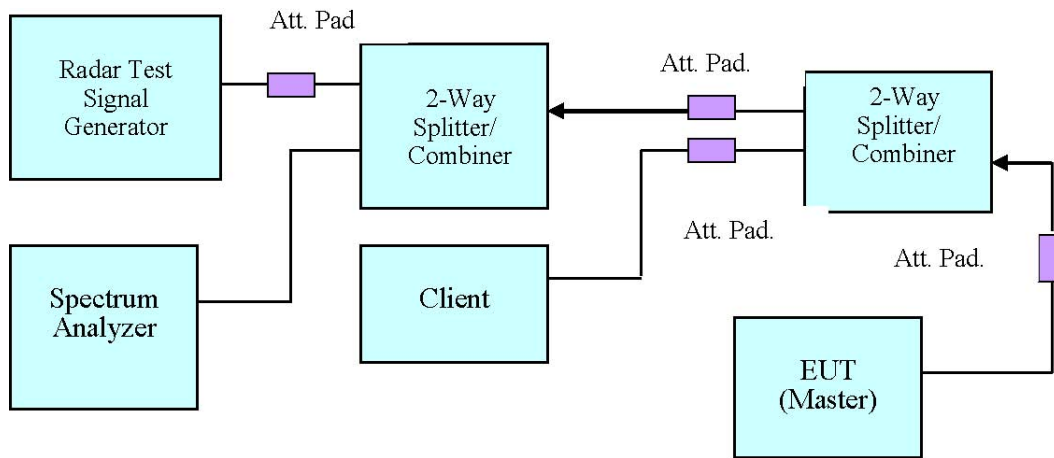

**Setup for Master with injection at the Master**

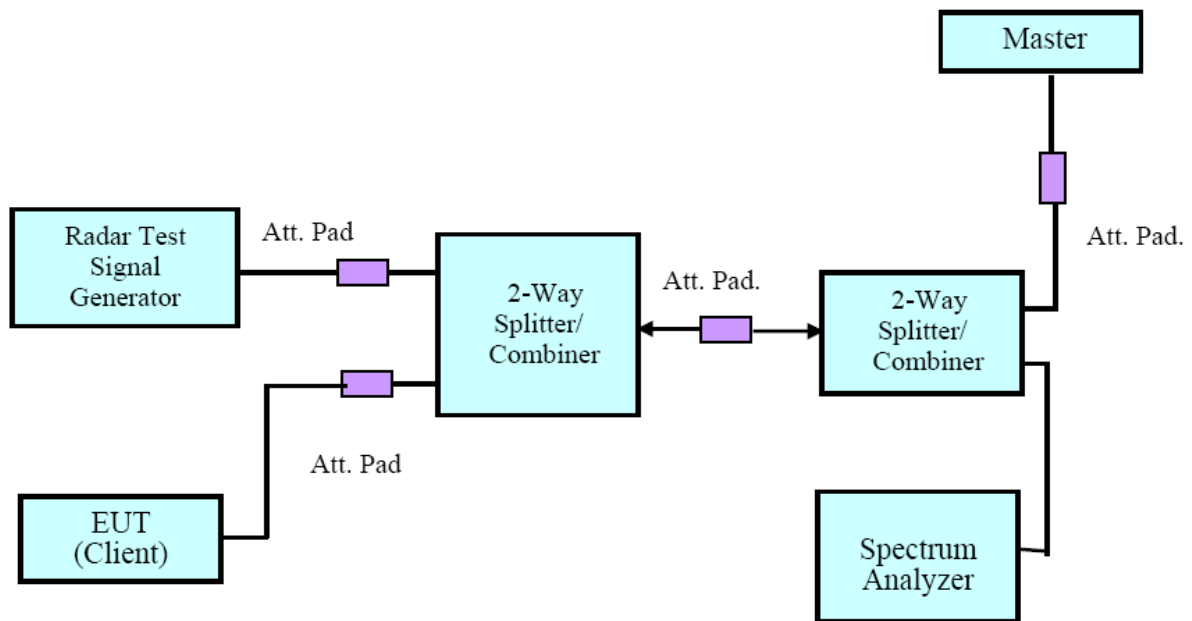

**Setup for Client with injection at the Master**

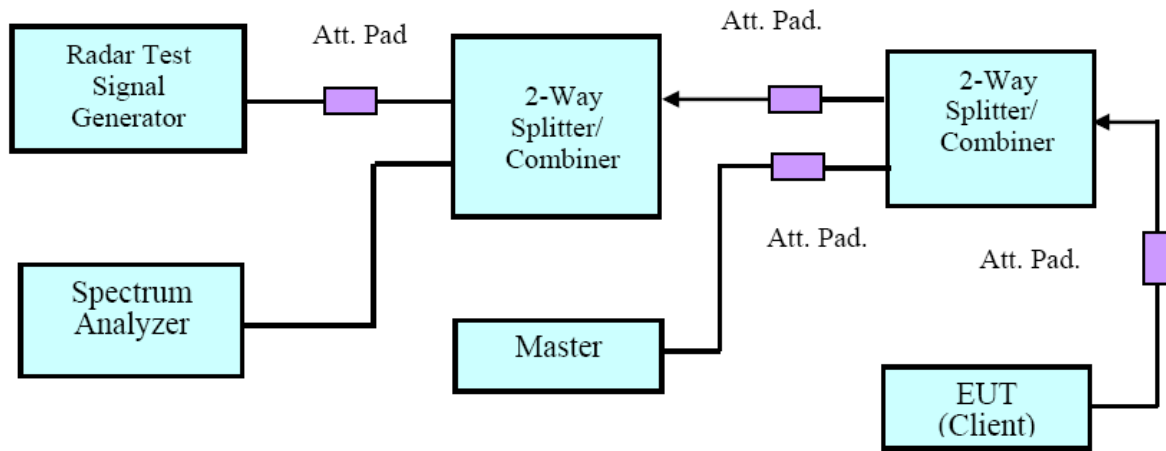

**Setup for Client with injection at the Client**

**4.5 Radiated Method**

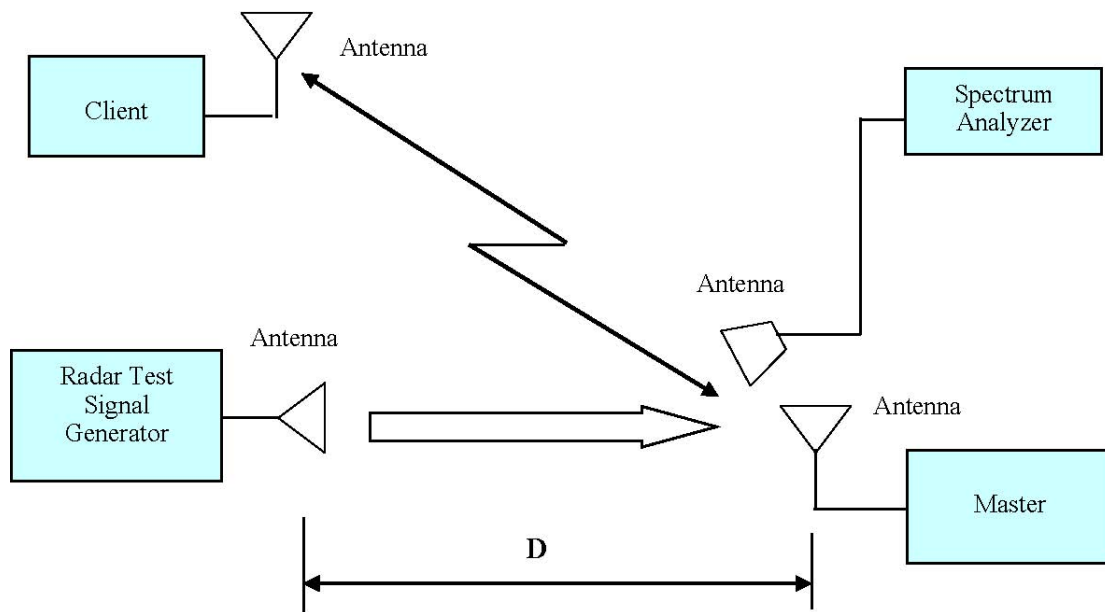

**4.6 Test Procedure**

A spectrum analyzer is used as a monitor verifies that the EUT status including Channel Closing Transmission Time and Channel Move Time, and does not transmit on a Channel during the Non-Occupancy Period after the diction and Channel move. It is also used to monitor EUT transmissions during the Channel Availability Check Time.

## TEST RESULTS

---

### Description of EUT

The EUT operates in 5250-5350 MHz and 5470-5725 MHz range.

The rated output power of client device is 10.71 dBm (EIRP) < 23 dBm and power spectral density < 10 dBm/MHz ,the required radiated threshold at antenna port is -62dBm.The calibrated radiated DFS detection threshold level is set to -62 dBm.

WLAN traffic is generated by streaming the video file TestFile.mpg, this file is used by IP and Frame based systems for loading the test channel during the In-service compliance testing of the U-NII device. The file is streamed from the Access Point to the Client in full motion video mode using the media player with the V2.61 Codec package.

### Test Environmental Conditions

<b>Temperature:</b>	24.3 ° C
<b>Relative Humidity:</b>	54 %
<b>ATM Pressure:</b>	103.2 kPa

*The testing was performed by Jack Jiao on 2020-12-02.*

Plots of Radar Waveforms

5310 MHz:

**Radar Type 0**

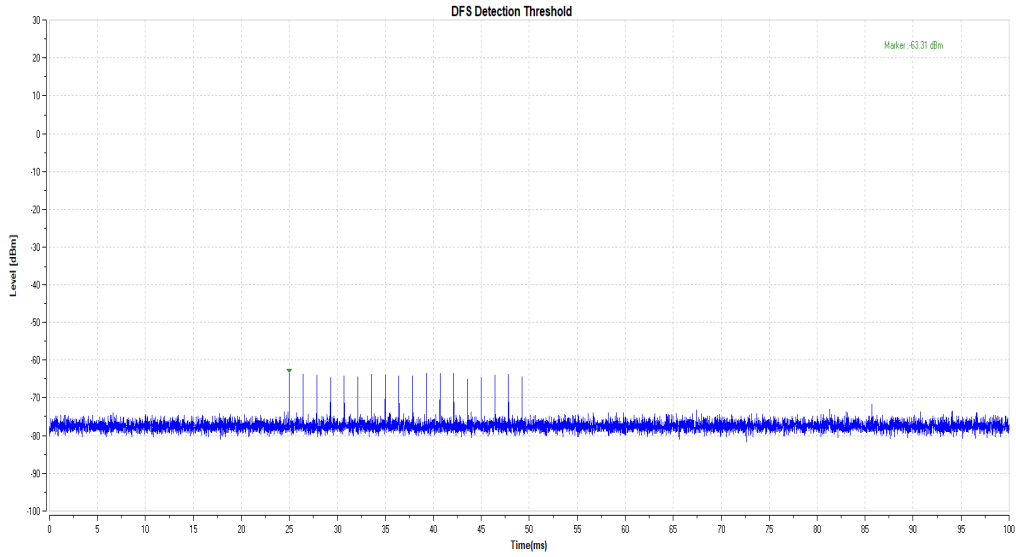

5510 MHz:

**Radar Type 0**

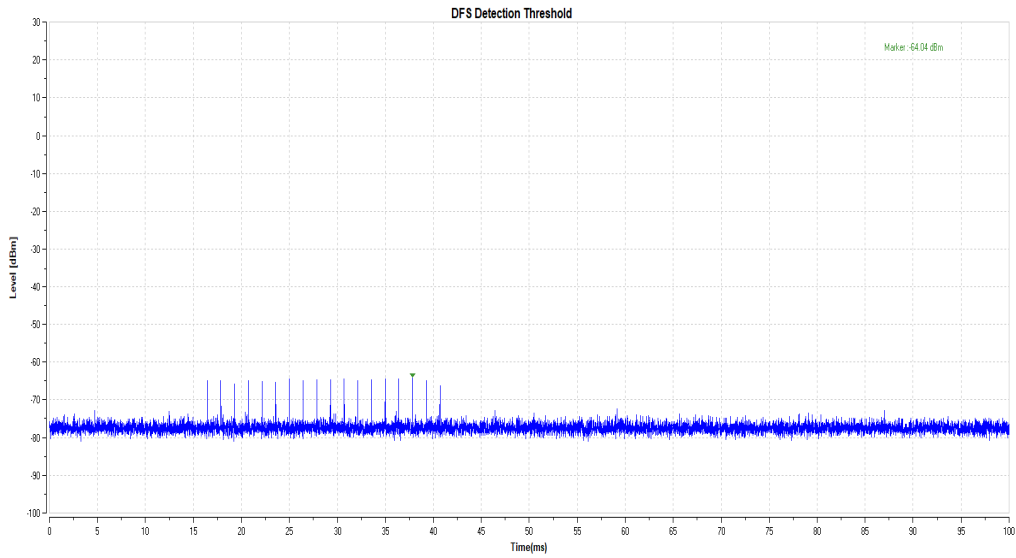



## CHANNEL MOVE TIME AND CHANNEL CLOSING TRANSMISSION TIME

---

### Test Procedure

Perform type 0 short pulse radar waveform,  
The aggregate channel closing transmission time is calculated as follows:

Aggregate Transmission Time = N\*Dwell Time

N is the number of spectrum analyzer bins showing a device transmission Dwell Time is the dwell time per bin (i.e. Dwell Time = S/B, S is the sweep time and B is the number of bin, i.e. 8192)

### Test Results

Frequency (MHz)	Bandwidth (MHz)	Radar Type	Results
5310	40	Type 0	Compliant
5510	40	Type 0	Compliant

Please refer to the following tables and plots.

5310 MHz

Transmission After 200ms	Aggregate Transmission Time After 200ms Delay (ms)	Limit for Aggregate Transmission Time After 200ms Delay (ms)	Result
Yes	31.2	60	Pass

Type 0 radar channel move time & channel closing transmission result:

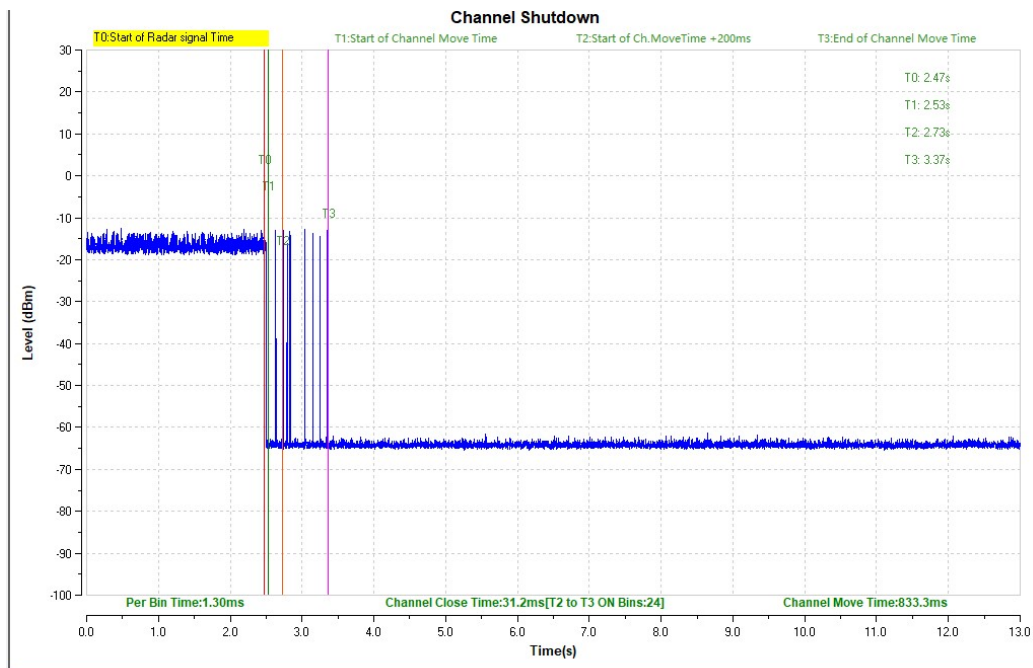

5510 MHz

Transmission After 200ms	Aggregate Transmission Time After 200ms Delay (ms)	Limit for Aggregate Transmission Time After 200ms Delay (ms)	Result
Yes	27.3	60	Pass

Type 0 radar channel move time & channel closing transmission result:

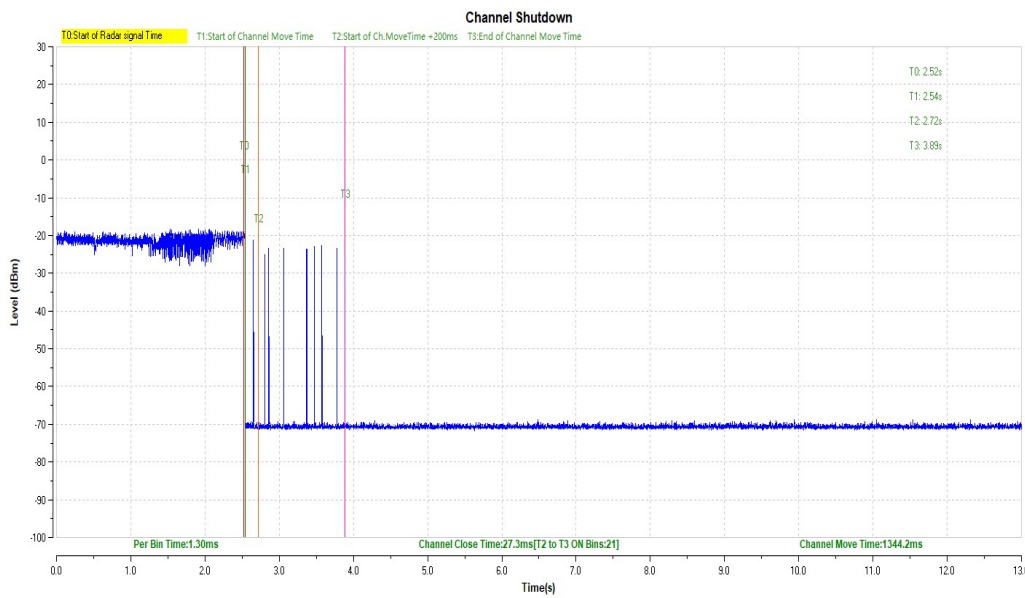

**NON-OCCUPANCY PERIOD****Test Procedure**

Measure the EUT for more than 30 minutes following the channel close/move time to verify that the EUT does not resume any transmissions on this channel. Provide one plot to demonstrate no transmission on the channel for the non-occupancy period (30 minutes observation time)

**Test Result**

Frequency(MHz)	Bandwidth (MHz)	Spectrum Analyzer Display
5310	40	No transmission within 30 minutes
5510	40	No transmission within 30 minutes

Please refer to the following plots.

### 5310 MHz

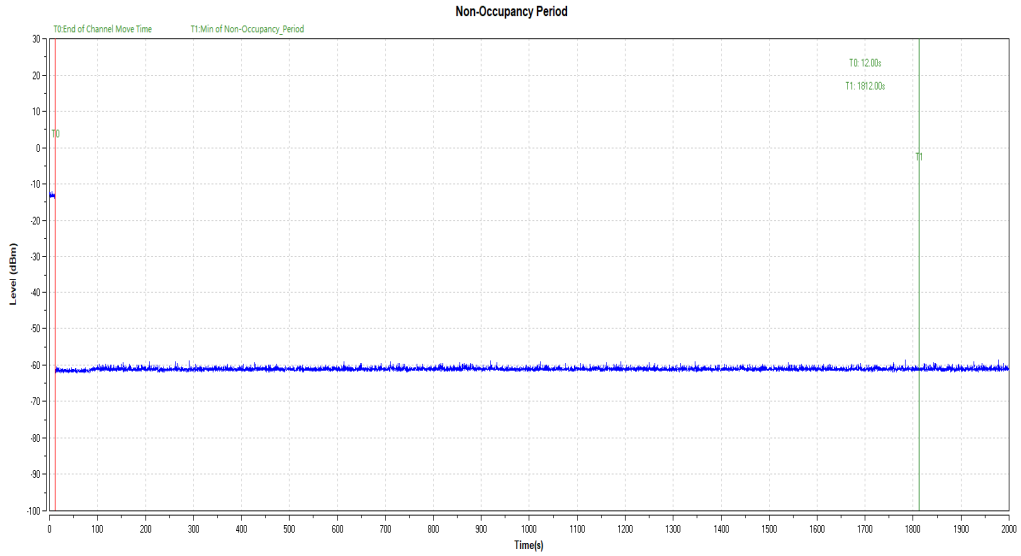

### 5510 MHz

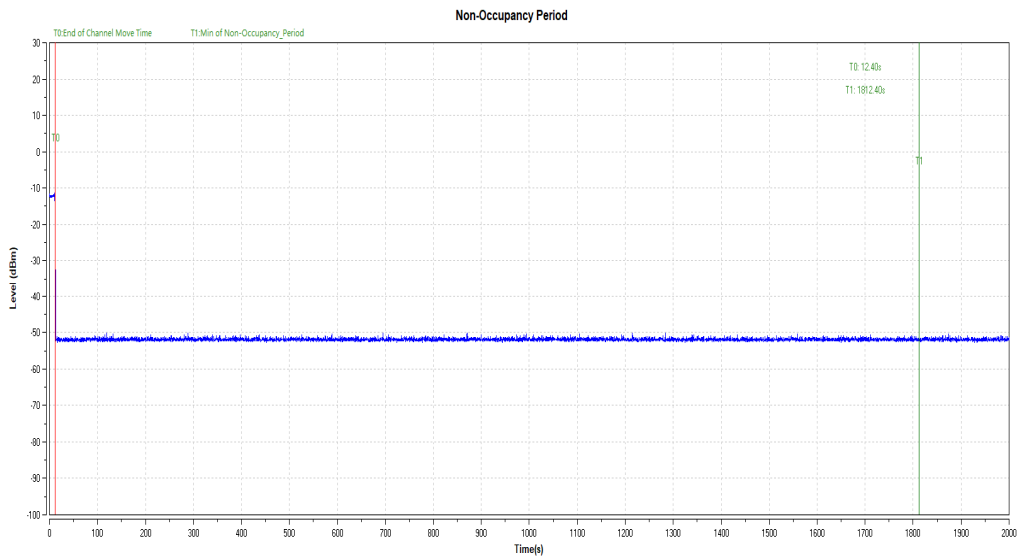

### **Declarations**

- 1: BACL is not responsible for the authenticity of any test data provided by the applicant. Data included from the applicant that may affect test results are marked with an asterisk '\*'. Customer model name, addresses, names, trademarks etc. are not considered data.
- 2: Unless otherwise stated the results shown in this test report refer only to the sample(s) tested.
- 3: Otherwise required by the applicant or Product Regulations, Decision Rule in this report did not consider the uncertainty.
- 4: The extended uncertainty given in this report is obtained by combining the standard uncertainty times the coverage factor K with the 95% confidence interval.
- 5: This report cannot be reproduced except in full, without prior written approval of the Company.
- 6: This report is valid only with a valid digital signature. The digital signature may be available only under the Adobe software above version 7.0.

**\*\*\*\*\* END OF REPORT \*\*\*\*\***