

FCC RADIO TEST REPORT

Applicant..... : ALFATRON ELECTRONICS GmbH
Address..... : Lichweg 12, 53604 Bad Honnef, Germany
Manufacturer..... : ALFATRON ELECTRONICS GmbH
Address..... : Lichweg 12, 53604 Bad Honnef, Germany
EUT : HD Webcam with wireless speaker microphone
Brand Name..... : ALFATRON
Model No. : ALF-CMW102, ALF-CMW101, ALF-CAM100
(For model difference refer to section 2)
FCC ID..... : 2AXMO-ALFCW
Measurement Standard..... : 47 CFR FCC Part 15, Subpart C (Section 15.249)
Receipt Date of Samples.... : September 19, 2020
Date of Tested..... : September 19, 2020 to March 10, 2021
Date of Report..... : May 21, 2021

This report shows that above equipment is technically compliant with the requirements of the standards above. All test results in this report apply only to the tested sample(s). Without prior written approval of Dongguan Nore Testing Center Co., Ltd, this report shall not be reproduced except in full.



Prepared by

Alina Guo / Project Engineer



Iori Fan / Authorized Signatory

Table of Contents

1. Summary of Test Result.....	4
2. General Description of EUT	5
3. Test Channels and Modes Detail.....	7
4. Configuration of EUT.....	7
5. Modification of EUT.....	7
6. Description of Support Device.....	8
7. Test Facility and Location	9
8. Applicable Standards and References.....	9
9. Deviations and Abnormalities from Standard Conditions	10
10. Test Conditions	10
11. Measurement Uncertainty.....	11
12. Sample Calculations	12
13. Test Items and Results	13
13.1 Conducted Emissions Measurement	13
13.2 Radiated Spurious Emissions and Restricted Bands Measurement.....	17
13.3 20dB Bandwidth Measurement.....	25
13.4 Antenna Requirement	27
14. Test Equipment List.....	28

1. Summary of Test Result

FCC Rules	Description of Test	Result	Remarks
§15.207 (a)	AC Power Conducted Emission	PASS	---
§15.249(a)/ 15.209	Radiated Emissions	PASS	---
§15.249(d)/ 15.205	Band Edge	PASS	---
§15.215(c)	20dB Bandwidth	PASS	---
§15.203	Antenna Requirement	PASS	---

2. General Description of EUT

Product Information	
Product name:	HD Webcam with wireless speaker microphone
Main Model Name:	ALF-CMW102
Additional Model Name:	ALF-CMW101, ALF-CAM100
Model Difference:	These models have the same circuit schematic, construction, PCB Layout and critical components. The difference in model number and combination due to trading purpose. ALF-CMW100 is HD Webcam, and ALF-CMW101 consists of one HD Webcam and one wireless speaker, and ALF-CMW102 consists of one HD Webcam and two wireless speakers.
S/N:	2009-3433
Brand Name:	ALFATRON
Hardware version:	ALF-CMW102
Software version:	V1.0
Rating:	DC 5V from USB port
Typical arrangement:	Table-top or wall-mounted
I/O Port:	USB Port*1
Accessories Information	
Adapter:	N/A
Other:	N/A
Additional information	
Note:	According to the model differences, all tests were carried on model ALF-CMW102.
Remark:	<p>1. All the information above are provided by the manufacturer. More detailed feature of the EUT please refers to the user manual.</p> <p>2. The EUT consists of HD Webcam and wireless microphone speaker unit. This report only applies to HD Webcam unit.</p>

Technical Specification (2.4G Function)	
Frequency Range:	2404-2476MHz
Modulation Type:	GFSK
Number of Channel:	19
Channel Space:	4MHz
Antenna Type:	PCB antenna
Antenna Gain:	0 dBi (Declared by manufacturer)

Channel List					
Channel	Frequency (MHz)	Channel	Frequency (MHz)	Channel	Frequency (MHz)
1	2404	8	2432	15	2460
2	2408	9	2436	16	2464
3	2412	10	2440	17	2468
4	2416	11	2444	18	2472
5	2420	12	2448	19	2476
6	2424	13	2452		
7	2428	14	2456		

3. Test Channels and Modes Detail

Mode		Channel		Frequency (MHz)	Modulation	Remark
1	TX	Low	1	2404	GFSK	---
2	TX	Mid	10	2440	GFSK	---
3	TX	High	19	2476	GFSK	---
4.	Normal Mode	---	---	---	---	---

Note: TX mode means that the EUT was programmed to be in continuously transmitting mode.

4. Configuration of EUT

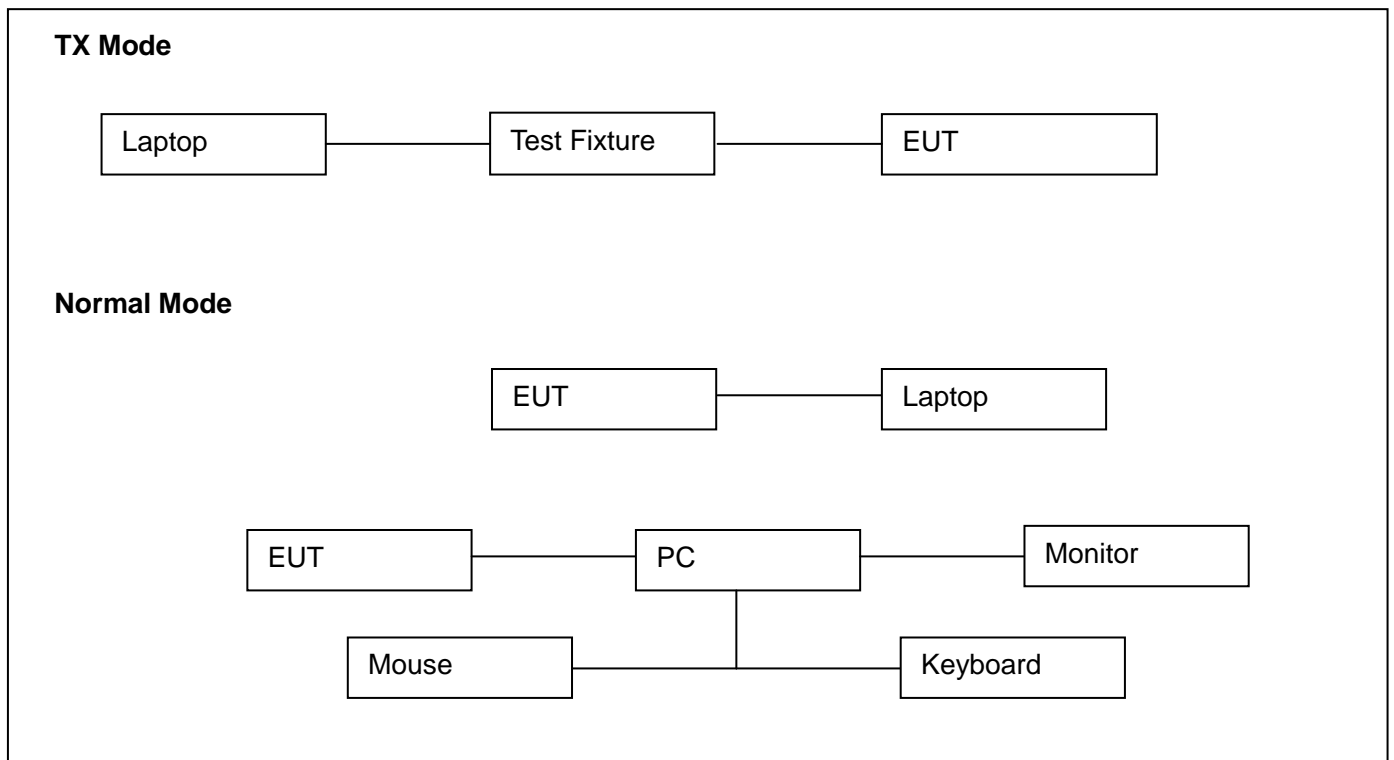

5. Modification of EUT

No modifications are made to the EUT during all test items.

6. Description of Support Device

The EUT has been tested as an independent unit together with other necessary accessories or support units. The following support units or accessories were used to form a representative test configuration during the tests.

No.	Equipment	Brand	M/N	S/N	Cable Specification	Remarks
1.	Test fixture	---	---	---	---	Provided by manufacturer
2.	Laptop	Lenovo	E31	0A33012	---	---
3.	Adapter	DELTA	92P1154	---	AC Line: 1.15m unshielded DC Line: 1.18m unshielded with a core	I/P: AC 100-240V 50-60Hz, 1.5A O/P: DC 20V 3.25A
4	PC	DELL	OptiPlex 7050	116190863	Power Cord: 1.8m Unshielded, with core	PC
5	Monitor	DELL	U2718Q	CN-05DW RH	Power Cord: 1.8m Unshielded, with core	Monitor
6	Keyboard	DELL	KB216d	---	USB Line: 1.21m unshielded	Keyboard

No.	Test Software	Modulation	Power Setting
1.	PurePath Wireless Commander -Texas Instruments	GFSK	-8dBm

7. Test Facility and Location

Test Site	:	Dongguan Nore Testing Center Co., Ltd. (Dongguan NTC Co., Ltd.)
Accreditations and Authorizations	:	<p>The Laboratory has been assessed and proved to be in compliance with CNAS/CL01</p> <p>Listed by CNAS, August 13, 2018</p> <p>The Certificate Registration Number is L5795.</p> <p>The Certificate is valid until August 13, 2024</p> <p>The Laboratory has been assessed and proved to be in compliance with ISO17025</p> <p>Listed by A2LA, November 01, 2017</p> <p>The Certificate Registration Number is 4429.01</p> <p>The Certificate is valid until December 31, 2021</p> <p>Listed by FCC, November 06, 2017</p> <p>Test Firm Registration Number: 907417</p> <p>Listed by Industry Canada, June 08, 2017</p> <p>The Certificate Registration Number. Is 46405-9743A</p>
Test Site Location	:	Building D, Gaosheng Science and Technology Park, Hongtu Road, Nancheng District, Dongguan City, Guangdong Province, China

8. Applicable Standards and References

According to the specifications of the manufacturer, the EUT must comply with the requirements of the following standards:

Test Standards:

47 CFR Part 15, Subpart C, 15.249

ANSI C63.10-2013

References Test Guidance:

N/A

9. Deviations and Abnormalities from Standard Conditions

No additions, deviations and exclusions from the standard.

10. Test Conditions

No.	Test Item	Test Mode	Test Voltage	Tested by	Remarks
1.	AC Power Conducted Emission	4	AC 120V 60Hz	Ray	See note 1
2.	Radiated Emissions	1-4	AC 120V 60Hz	Ray	See note 1
3.	Band Edge	1-3	AC 120V 60Hz	Ray	See note 1
4.	20dB Bandwidth	1-3	AC 120V 60Hz	Ray	See note 1
5.	Antenna Requirement	---	---	---	---

Note:

- The testing climatic conditions for temperature, humidity, and atmospheric pressure are within: 15~35 °C, 30~70%, 86~106kPa
- As the EUT can be operated multiple positions, all X,Y,Z axis were considered during the test and only the worst case X was recorded.
- AC 120V 60Hz is input voltage of the PC.

11. Measurement Uncertainty

No.	Test Item	Frequency	Uncertainty	Remarks
1.	Conducted Emission	150KHz ~ 30MHz	±2.52 dB	---
2.	Radiated Emission Test	9kHz ~ 30MHz	±2.60 dB	---
		30MHz ~ 1GHz	±4.68 dB	---
		1GHz ~ 18GHz	±5.14 dB	---
		18GHz ~ 40GHz	±5.14 dB	---

Note:

1. This uncertainty represents an expanded uncertainty expressed at approximately the 95% confidence level using a coverage factor of k=2.
2. The measurement uncertainty levels above are estimated and calculated according to CISPR 16-4-2.
3. The conformity assessment statement in this report is based solely on the test results, measurement uncertainty is excluded.

12. Sample Calculations

Conducted Emission						
Freq. (MHz)	Reading Level (dBuV)	Correct Factor (dB)	Measurement (dBuV)	Limit (dBuV)	Over (dB)	Detector
0.1900	30.10	10.60	40.70	79.00	-38.30	QP

Where,

Freq. = Emission frequency in MHz
 Reading Level = Uncorrected Analyzer/Receiver reading
 Corrector Factor = Insertion loss of LISN + Cable Loss + RF Switching Unit attenuation
 Measurement = Reading + Corrector Factor
 Limit = Limit stated in standard
 Margin = Measurement - Limit
 Detector = Reading for Quasi-Peak / Average / Peak

Radiated Spurious Emissions and Restricted Bands						
Freq. (MHz)	Reading Level (dBuV)	Correct Factor (dB/m)	Measurement (dBuV/m)	Limit (dBuV/m)	Over (dB)	Detector
60.0700	45.88	-18.38	27.50	49.00	-21.50	QP

Where,

Freq. = Emission frequency in MHz
 Reading Level = Uncorrected Analyzer/Receiver reading
 Corrector Factor = Antenna Factor + Cable Loss - Pre-amplifier
 Measurement = Reading + Corrector Factor
 Limit = Limit stated in standard
 Over = Margin, which calculated by Measurement - Limit
 Detector = Reading for Quasi-Peak / Average / Peak

Note: For all conducted test items, the spectrum analyzer offset or transducer is derived from RF cable loss and attenuator factor. The offset or transducer is equal to the RF cable loss plus attenuator factor.

13. Test Items and Results

13.1 Conducted Emissions Measurement

LIMIT

According to the requirements of FCC PART 15.207, the limits are as follows:

Frequency (MHz)	Quasi-peak	Average
0.15 to 0.5	66 to 56	56 to 46
0.5 to 5	56	46
5 to 30	60	50

Note: 1. If the limits for the average detector are met when using the quasi-peak detector, then the limits for the measurements with the average detector are considered to be met.
 2. The lower limit shall apply at the transition frequencies.
 3. The limit decreases linearly with the logarithm of the frequency in the range 0.15 MHz to 0.5MHz.

BLOCK DIAGRAM OF TEST SETUP

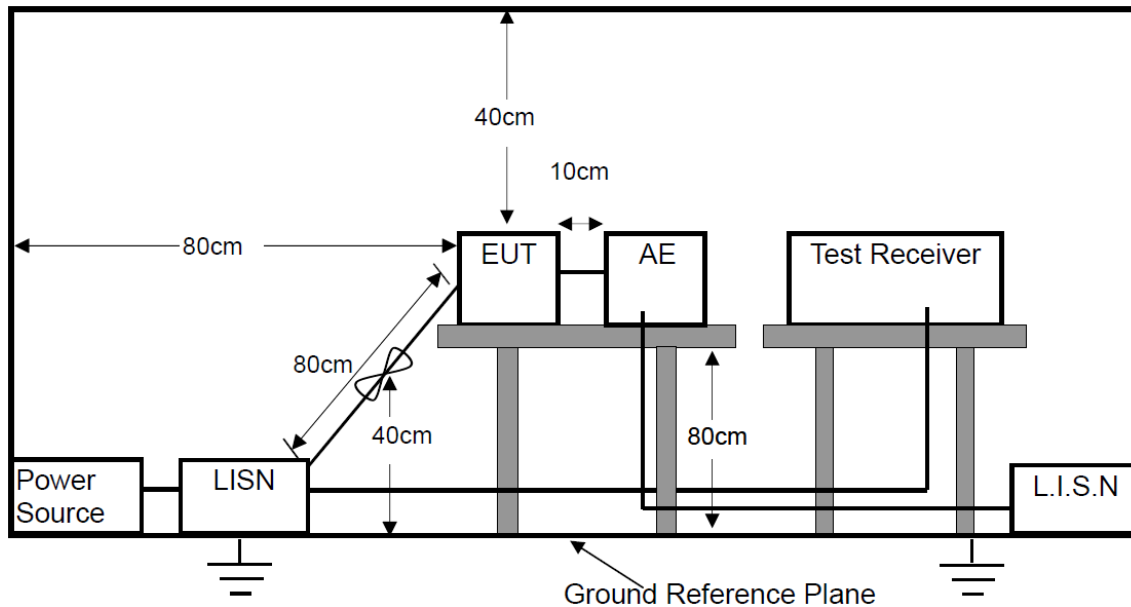

TEST PROCEDURES

- a. The EUT was placed on a wooden table 0.8m height from the metal ground plan and 0.4m from the conducting wall of the shielding room and it was kept at 0.8m from any other grounded conducting surface.
- b. All I/O cables and support devices were positioned as per ANSI C63.10.
- c. Connect mains power port of the EUT to a line impedance stabilization network (LISN).
- d. Connect all support devices to the other LISN and AAN, if needed.
- e. Scan the frequency range from 150KHz to 30MHz at both sides of AC line for maximum conducted interference checking and record the test data.

TEST RESULTS

PASS

Please refer to the following pages.

M/N: ALF-CMW102	Testing Voltage: AC 120V/60Hz
Phase: L1	Detector: QP & AVG
Test Mode: 4	

Conducted Emission Measurement

Date: 2021/2/23

Time: 16:59:40

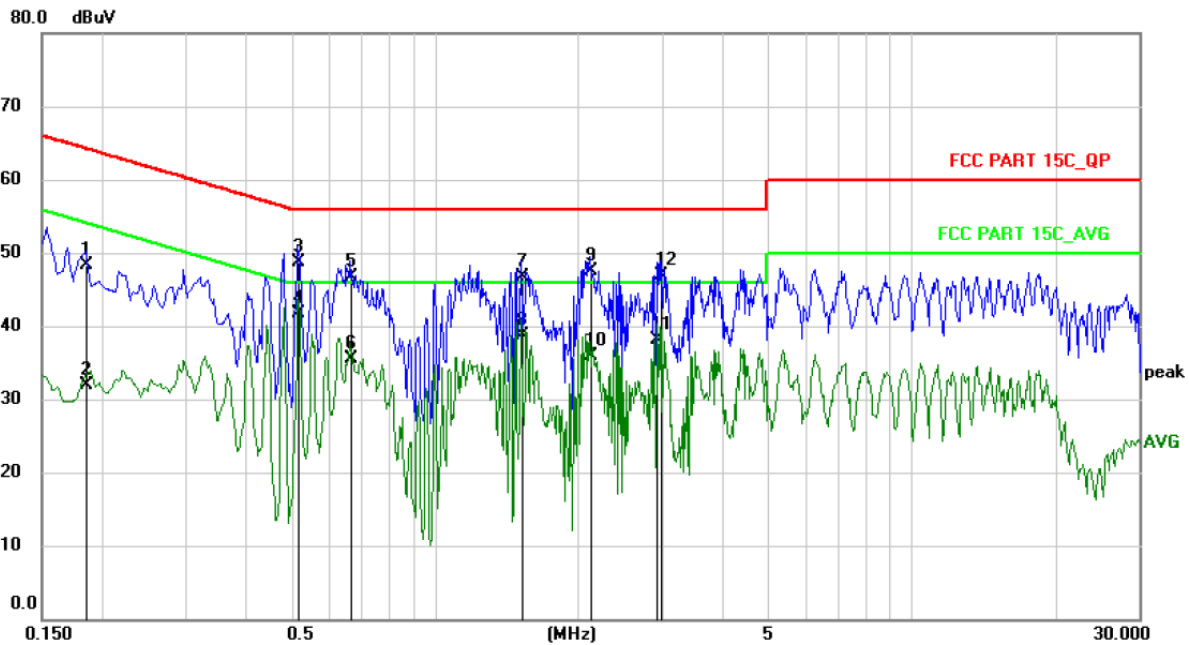

No. Mk.	Freq. MHz	Reading Level dBuV	Correct Factor dB	Measurement dBuV	Limit dBuV	Over dB	Detector	Comment
1	0.1859	37.70	10.60	48.30	64.22	-15.92	QP	
2	0.1859	21.30	10.60	31.90	54.22	-22.32	AVG	
3	0.5180	38.17	10.63	48.80	56.00	-7.20	QP	
4 *	0.5180	31.17	10.63	41.80	46.00	-4.20	AVG	
5	0.6660	36.15	10.65	46.80	56.00	-9.20	QP	
6	0.6660	24.95	10.65	35.60	46.00	-10.40	AVG	
7	1.5220	36.00	10.70	46.70	56.00	-9.30	QP	
8	1.5220	28.10	10.70	38.80	46.00	-7.20	AVG	
9	2.1139	36.80	10.70	47.50	56.00	-8.50	QP	
10	2.1139	25.20	10.70	35.90	46.00	-10.10	AVG	
11	2.9260	27.49	10.71	38.20	46.00	-7.80	AVG	
12	2.9620	36.19	10.71	46.90	56.00	-9.10	QP	

M/N: ALF-CMW102	Testing Voltage: AC 120V/60Hz
Phase: N	Detector: QP & AVG
Test Mode: 4	

Conducted Emission Measurement

Date: 2021/2/23

Time: 16:53:01

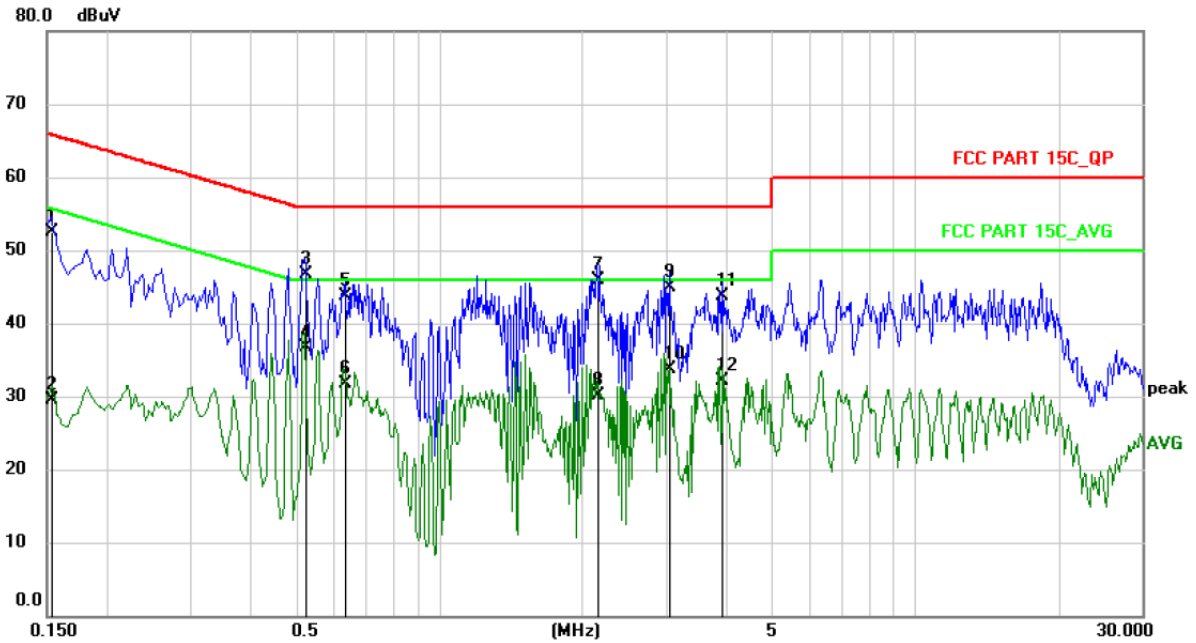

No. Mk.	Freq.	Reading Level	Correct Factor	Measurement	Limit	Over	Detector	Comment
	MHz	dBuV	dB	dBuV	dBuV	dB		
1	0.1539	42.00	10.60	52.60	65.79	-13.19	QP	
2	0.1539	18.90	10.60	29.50	55.79	-26.29	AVG	
3 *	0.5220	36.17	10.63	46.80	56.00	-9.20	QP	
4	0.5220	26.17	10.63	36.80	46.00	-9.20	AVG	
5	0.6340	33.05	10.65	43.70	56.00	-12.30	QP	
6	0.6340	21.05	10.65	31.70	46.00	-14.30	AVG	
7	2.1540	35.30	10.70	46.00	56.00	-10.00	QP	
8	2.1540	19.40	10.70	30.10	46.00	-15.90	AVG	
9	3.0419	34.29	10.71	45.00	56.00	-11.00	QP	
10	3.0419	23.09	10.71	33.80	46.00	-12.20	AVG	
11	3.9340	33.09	10.71	43.80	56.00	-12.20	QP	
12	3.9340	21.39	10.71	32.10	46.00	-13.90	AVG	

13.2 Radiated Spurious Emissions and Restricted Bands Measurement

LIMIT

Frequency range MHz	Distance Meters	Field Strengths Limit (15.209)	
		μV/m	
0.009 ~ 0.490	300	2400/F(kHz)	
0.490 ~ 1.705	30	24000/F(kHz)	
1.705 ~ 30	30	30	
30 ~ 88	3	100	
88 ~ 216	3	150	
216 ~ 960	3	200	
Above 960	3	500	
Frequency range MHz	Distance Meters	Field Strengths Limit (15.249)	
		mV/m (Field strength of fundamental)	μV/m (Field strength of Harmonics)
902 ~ 928	3	50	500
2400 ~ 2483.5	3	50	500
5725 ~ 5875	3	50	500
24000 ~ 2425000	3	250	2500

- Remark: (1) Emission level (dB)μV = 20 log Emission level μV/m
- (2) The smaller limit shall apply at the cross point between two frequency bands.
- (3) As shown in 15.35(b), for frequencies above 1000MHz, the field strength limits are based on average detector, however, the peak field strength of any emission shall not exceed the maximum permitted average limits, specified above by more than 20dB under any condition of modulation.
- (4) The frequency range scanned is from the lowest radio frequency signal generated in the device which is greater than 9 kHz to the tenth harmonic of the highest fundamental frequency or 40 GHz, whichever is lower.
- (5) §15.249(d) specifies that emissions which fall in the restricted bands, as defined in §15.205 comply with radiated emission limits specified in §15.209.

BLOCK DIAGRAM OF TEST SETUP

For Radiated Emission below 30MHz

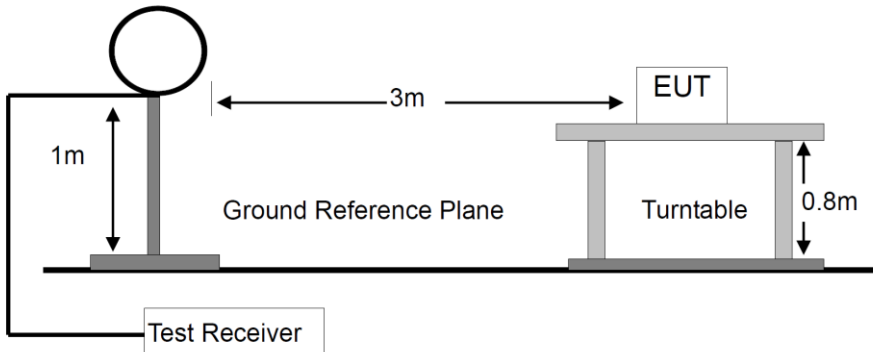

For Radiated Emission 30-1000MHz

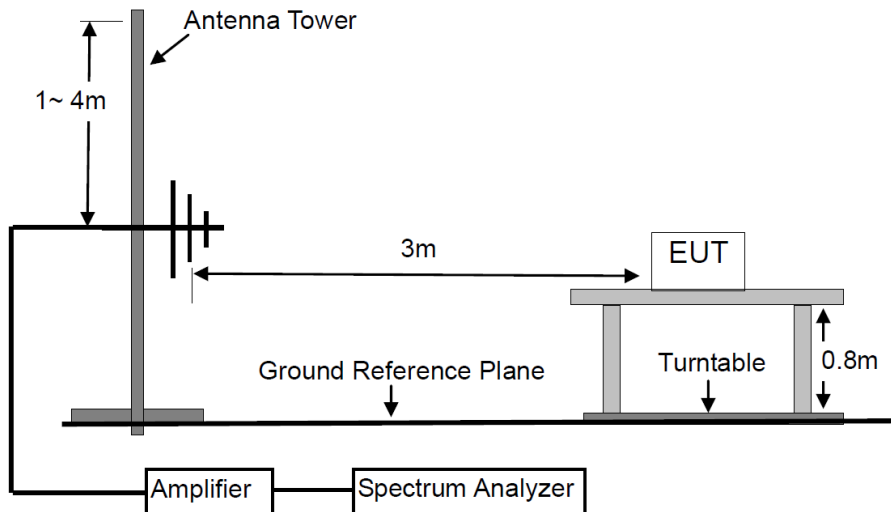

For Radiated Emission Above 1000MHz.

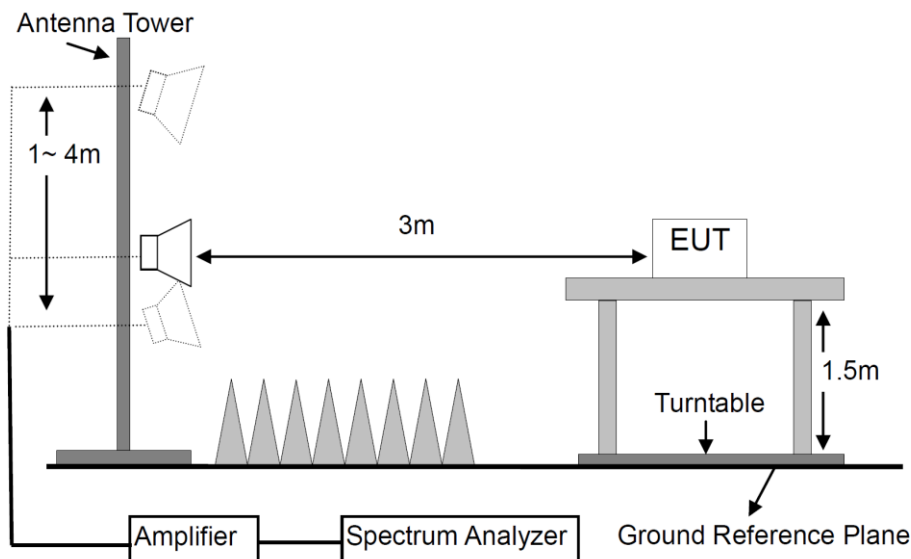

TEST PROCEDURES

- a. Below 1GHz, the EUT was placed on the top of a rotating table 0.8 meters above the ground at a 3 meter semi- anechoic chamber room.
- b. For the radiated emission test above 1GHz:
The EUT was placed on the top of a rotating table 1.5 meters above the ground at a 3 meter full anechoic chamber room. The table was rotated 360 degrees to determine the position of the highest radiation. Place the measurement antenna away from each area of the EUT determined to be a source of emissions at the specified measurement distance, while keeping the measurement antenna aimed at the source of emissions at each frequency of significant emissions, with polarization oriented for maximum response. The measurement antenna may have to be higher or lower than the EUT, depending on the radiation pattern of the emission and staying aimed at the emission source for receiving the maximum signal. The final measurement antenna elevation shall be that which maximizes the emissions. The measurement antenna elevation for maximum emissions shall be restricted to a range of heights of from 1 m to 4 m above the ground or reference ground plane.
- c. The EUT was set 3 meters away from the interference-receiving antenna, which was mounted on the top of a variable-height antenna tower.
- d. The height of antenna is varied from one meter to four meters above the ground to determine the maximum value of the field strength. Both horizontal and vertical polarizations of the antenna are set to make the measurement.
- e. For each suspected emission, the EUT was arranged to its worst case and then the antenna was tuned to heights from 1 meter to 4 meters and the rotatable table was turned from 0 degrees to 360 degrees to find the maximum reading. The test-receiver system was set to peak detect function and specified bandwidth with maximum hold mode.
- f. A Quasi-peak measurement was then made for that frequency point for below 1GHz test. PK and AV for above 1GHz emission test.

During the radiated emission test, the spectrum analyzer was set with the following configurations:

Frequency Band (MHz)	Detector	Resolution Bandwidth	Video Bandwidth
30 to 1000	QP	120 kHz	300 kHz
Above 1000	Peak	1 MHz	3 MHz
	Average	1 MHz	10 Hz

TEST RESULTS

PASS

Please refer to the following pages.

M/N: ALF-CMW102	Testing Voltage: AC 120V/60Hz
Polarization: Horizontal	Detector: QP
Test Mode: 1 (the worst case)	Distance: 3m

Radiated Emission Measurement

Date: 2021/2/24

Time: 11:44:25

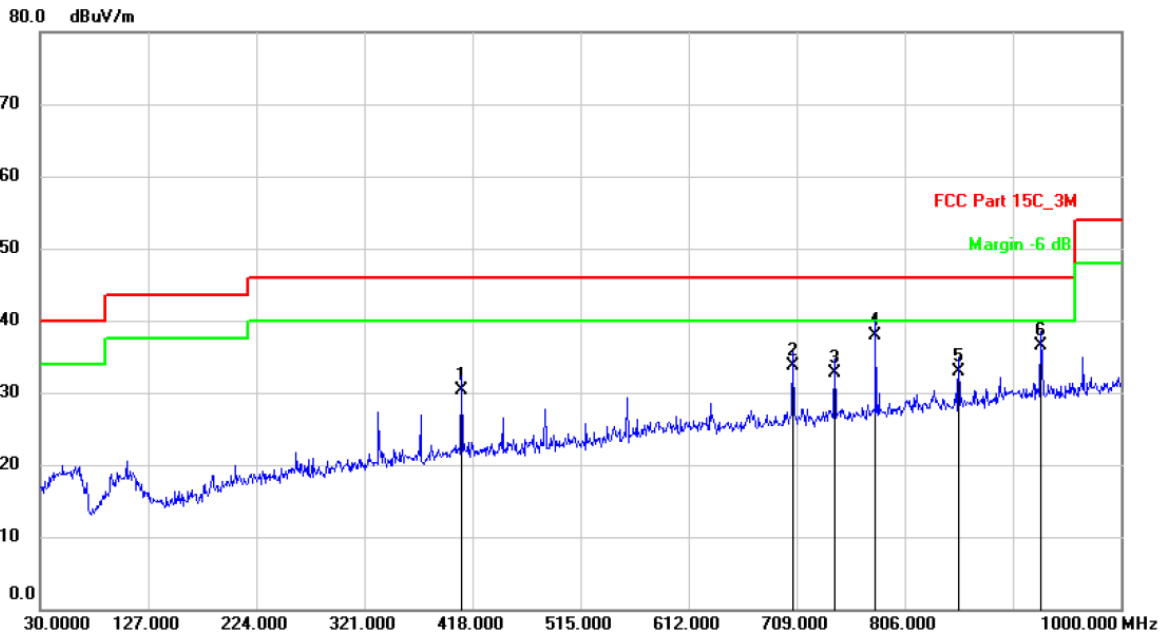

No.	Mk.	Freq. MHz	Reading Level dBuV	Correct Factor dB/m	Measure- ment dBuV/m	Limit dBuV/m	Over dB	Detector	Comment
1		408.3000	33.49	-3.19	30.30	46.00	-15.70	QP	
2		705.1200	31.53	2.27	33.80	46.00	-12.20	QP	
3		742.9500	29.88	2.92	32.80	46.00	-13.20	QP	
4	*	779.8100	34.41	3.59	38.00	46.00	-8.00	QP	
5		854.5000	28.07	4.83	32.90	46.00	-13.10	QP	
6		928.2200	30.36	6.24	36.60	46.00	-9.40	QP	

Note: Below 30MHz, the emissions are lower than 20dB below the allowable limit.

M/N: ALF-CMW102	Testing Voltage: AC 120V/60Hz
Polarization: Vertical	Detector: QP
Test Mode: 1(the worst case)	Distance: 3m

Radiated Emission Measurement

Date: 2021/2/24

Time: 11:51:28

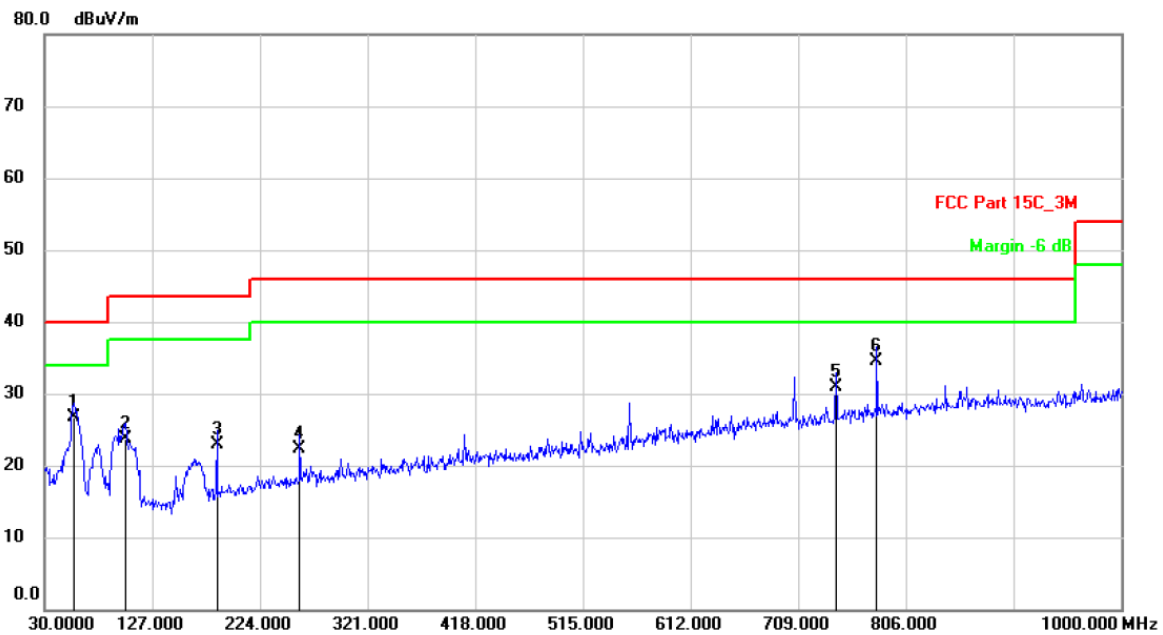

No.	Mk.	Freq. MHz	Reading Level dBuV	Correct Factor dB/m	Measure- ment dBuV/m	Limit dBuV/m	Over dB	Detector	Comment
1		56.1900	34.42	-7.72	26.70	40.00	-13.30	QP	
2		102.7500	32.71	-8.91	23.80	43.50	-19.70	QP	
3		185.2000	32.14	-9.24	22.90	43.50	-20.60	QP	
4		259.8900	29.46	-7.16	22.30	46.00	-23.70	QP	
5		742.9500	27.98	2.92	30.90	46.00	-15.10	QP	
6	*	779.8100	30.91	3.59	34.50	46.00	-11.50	QP	

Note: Below 30MHz, the emissions are lower than 20dB below the allowable limit.

Modulation: GFSK		Test Result: PASS					Test frequency range: 1-25GHz			
Freq. (MHz)	Ant. Pol. (H/V)	Reading Level(dBuV)		Factor (dB/m)	Emission Level (dBuV/m)		Limit 3m (dBuV/m)		Margin (dB)	
		PK	AV		PK	AV	PK	AV	PK	AV
Operation Mode: TX Mode (Low)										
2404	V	95.14	82.04	0.14	95.28	82.18	114.00	94.00	-18.72	-11.82
4808	V	47.90	32.78	6.33	54.23	39.11	74.00	54.00	-19.77	-14.89
7212	V	47.77	34.79	10.44	58.21	45.23	74.00	54.00	-15.79	-8.77

2404	H	103.35	90.04	0.14	103.49	90.18	114.00	94.00	-10.51	-3.82
4808	H	53.36	39.00	6.33	59.69	45.33	74.00	54.00	-14.31	-8.67
7212	H	53.22	40.44	10.44	63.66	50.88	74.00	54.00	-10.34	-3.12

Operation Mode: TX Mode (Mid)										
2440	V	94.30	81.36	0.23	94.53	81.59	114.00	94.00	-19.47	-12.41
4880	V	46.52	32.45	6.60	53.12	39.05	74.00	54.00	-20.88	-14.95
7320	V	46.34	33.58	10.55	56.89	44.13	74.00	54.00	-17.11	-9.87

2440	H	102.33	89.62	0.23	102.56	89.85	114.00	94.00	-11.44	-4.15
4880	H	52.63	37.50	6.60	59.23	44.10	74.00	54.00	-14.77	-9.90
7320	H	52.04	39.97	10.55	62.59	50.52	74.00	54.00	-11.41	-3.48

Operation Mode: TX Mode (High)										
2476	V	94.42	81.04	0.33	94.75	81.37	114.00	94.00	-19.25	-12.63
4952	V	47.31	33.39	6.86	54.17	40.25	74.00	54.00	-19.83	-13.75
7428	V	46.92	33.80	10.59	57.51	44.39	74.00	54.00	-16.49	-9.61

2476	H	101.82	88.80	0.33	102.15	89.13	114.00	94.00	-11.85	-4.87
4952	H	51.50	37.03	6.86	58.36	43.89	74.00	54.00	-15.64	-10.11
7428	H	51.53	39.21	10.59	62.12	49.80	74.00	54.00	-11.88	-4.20

Remark: Data of measurement within this frequency range shown “---” in the table above means the reading of emissions are attenuated more than 10dB below the permissible limits.

Band edge										
2390.000	V	50.56	38.14	0.09	50.65	38.23	74.00	54.00	-23.35	-15.77
2390.000	H	55.62	40.19	0.09	55.71	40.28	74.00	54.00	-18.29	-13.72
2483.500	V	53.35	40.17	0.34	53.69	40.51	74.00	54.00	-20.31	-13.49
2483.500	H	49.93	36.73	0.34	50.27	37.07	74.00	54.00	-23.73	-16.93

Note: Other band edge, the emissions are lower than 20dB below the allowable limit.

Low channel

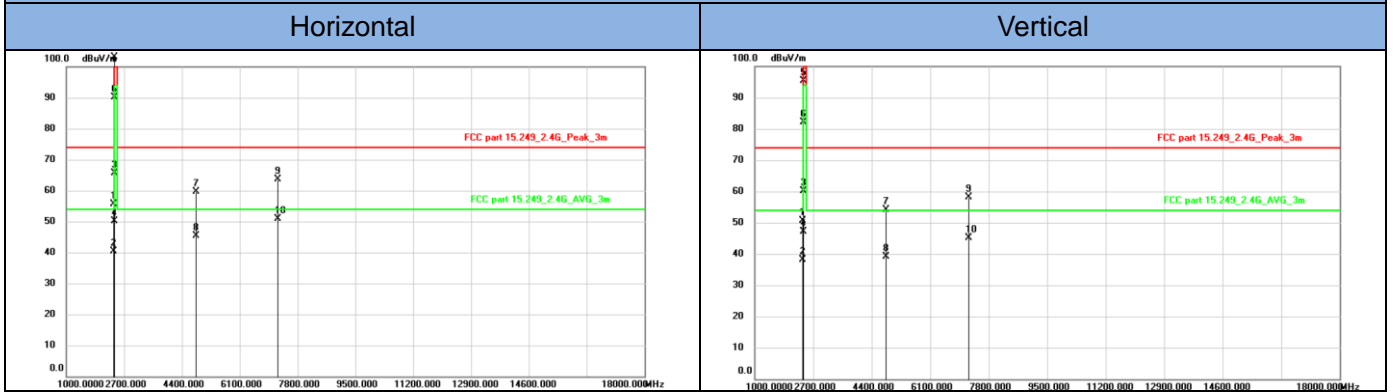

High channel

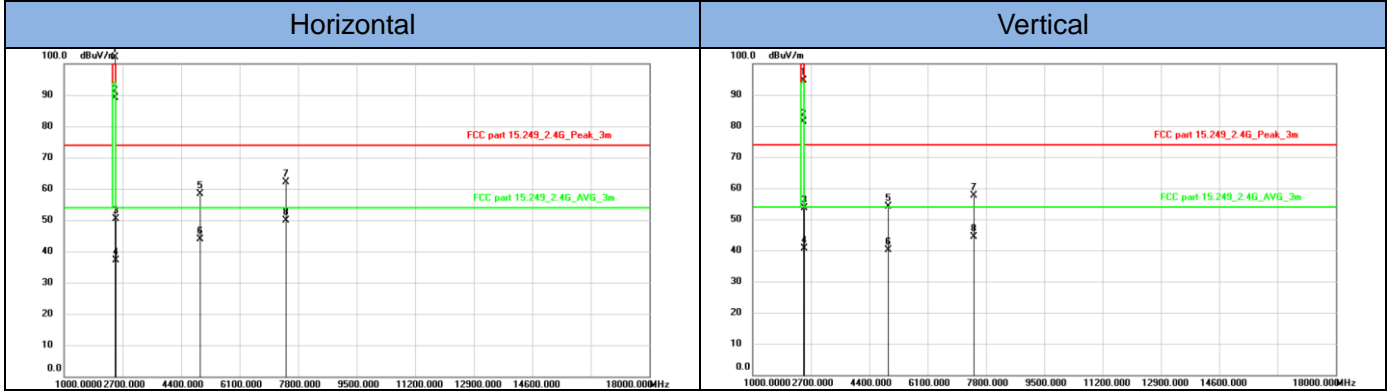

13.3 20dB Bandwidth Measurement

LIMIT

There is no limit.

BLOCK DIAGRAM OF TEST SETUP

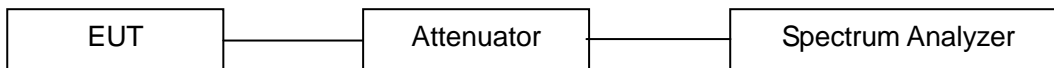

TEST PROCEDURES

The 20dB bandwidth of the emission was contained within the frequency band designated which the EUT operated. The effects, if any, from frequency sweeping, frequency hopping, other modulation techniques and frequency stability over excepted variations in temperature and supply voltage were considered, FCC Rule 15.215(c):

The antenna port of the EUT was connected to the input of a spectrum analyzer. Analyzer RBW was chosen so that the display was a result of the hopping channel modulation. For each RF output channel investigated, the spectrum analyzer center frequency was set to the channel carrier. Use the spectrum 20dB down delta function to measure the bandwidth.

TEST RESULTS

PASS

Please refer to the following table.

GFSK			
Channel	Frequency (MHz)	20dB Bandwidth (MHz)	Result
1	2404	4.307	PASS
10	2440	4.103	PASS
19	2476	4.312	PASS

2404MHz	2440MHz
---------	---------

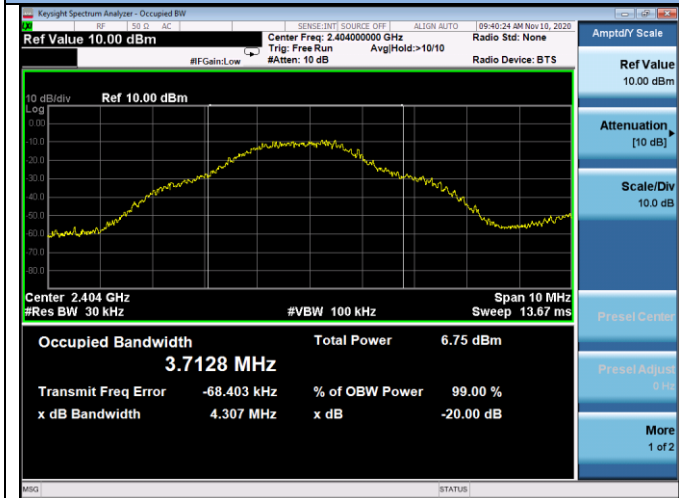

2476MHz	----
---------	------

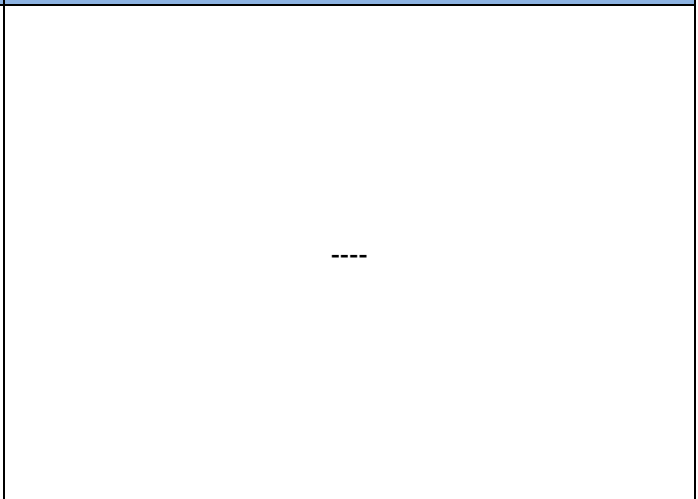

13.4 Antenna Requirement

STANDARD APPLICABLE

According to of FCC part 15C section 15.203 and 15.240:

An intentional radiator shall be designed to ensure that no antenna other than that furnished by the responsible party shall be used with the device. The use of a permanently attached antenna or of an antenna that uses a unique coupling to the intentional radiator, the manufacturer may design the unit so that a broken antenna can be replaced by the user, but the use of a standard antenna jack or electrical connector is prohibited.

Systems operating in the 2400-2483.5MHz band that are used exclusively for fixed, point-to-point operations may employ transmitting antennas with directional gain greater than 6dBi provided the maximum peak output power of the intentional radiator is reduced by 1dB for every 3dB that the directional gain of the antenna exceeds 6dBi.

ANTENNA CONNECTED CONSTRUCTION

The antenna is PCB antenna that no antenna other than furnished by the responsible party shall be used with the device, and the best case gain of the antenna is 0 dBi, Therefore, the antenna is consider meet the requirement.

14. Test Equipment List

Item	Equipment	Manufacturer	Model No.	Serial No.	Last Cal.	Cal. Interval
1.	Test Receiver	Rohde & Schwarz	ESCI7	100837	Mar. 13, 2020	1 Year
2.	Antenna	Schwarzbeck	VULB9162	9162-010	Mar. 23, 2020	1 Year
3.	Spectrum Analyzer	Rohde & Schwarz	FSU26	200409/026	Mar. 13, 2020	1 Year
4.	Spectrum Analyzer	Keysight	N9020A	MY54200831	Mar. 13, 2020	1 Year
5.	Spectrum Analyzer	Rohde & Schwarz	FSV40	101094	Mar. 13, 2020	1 Year
6.	Horn Antenna	Schwarzbeck	BBHA9170	9170-172	Mar. 22, 2019	2 Year
7.	Power Sensor	DARE	RPR3006W	15I00041SNO 64	Mar. 13, 2020	1 Year
8.	Communication Tester	Rohde & Schwarz	CMW500	149004	Mar. 13, 2020	1 Year
9.	Horn Antenna	COM-Power	AH-118	071078	Mar. 23, 2020	1 Year
10.	Pre-Amplifier	HP	HP 8449B	3008A00964	Mar. 13, 2020	1 Year
11.	Pre-Amplifier	HP	HP 8447D	1145A00203	Mar. 13, 2020	1 Year
12.	Loop Antenna	Schwarzbeck	FMZB 1513	1513-272	Mar. 23, 2020	1 Year
13.	Test Receiver	Rohde & Schwarz	ESCI	101152	Mar. 14, 2020	1 Year
14.	L.I.S.N	Rohde & Schwarz	ENV 216	101317	Mar. 13, 2020	1 Year
15.	L.I.S.N	Rohde & Schwarz	ESH2-Z5	893606/014	Mar. 13, 2020	1 Year
16.	RF Switching Unit	Compliance Direction Systems Inc.	RSU-M2	38311	Mar.13, 2020	1 Year
17.	Temperature & Humidity Chamber	REMAFEE	SYHR225L	N/A	Mar. 13, 2020	1 Year
18.	DC Source	Maynuo	MY8811	N/A	Mar. 13, 2020	1 Year
19.	Temporary antenna connector	TESCOM	SS402	N/A	N/A	N/A
20.	Chamber	SAEMC	9*7*7m	N/A	Jun. 20, 2019	2 Year
21.	Test Software	EZ	EZ_EM C	N/A	N/A	N/A

Note: For photographs of EUT and measurement, please refer to appendix in separate documents.

---End---