

RF Test Report

Project Number: 4793973 **Proposal:** SUW-202105000972
Report Number: 4793973EMC01 **Revision Level:** 0
Client: Mueller Systems, LLC.

Equipment Under Test: Smart Hydrant with BG95 4G LTE Module

Model Number: SH-GW-V1

FCC ID: 2AXKR-SH-GW-V1

Contains FCC ID: XMR202005BG95M5

Contains IC ID: 10224A-2020BG95M5

Test Standard: ANSI C63.26:2015

FCC Rule Parts: Part 22(H), Part 24(E), Part 27

IC Specifications: RSS-130 Issue 2, RSS-132 Issue 3; RSS-133 Issue 6

RSS-139 Issue 3; RSS-140 Issue 1; RSS-GEN, Issue 5

Report issued on: 30 September 2021

Test Result: Compliant



FOR THE SCOPE OF ACCREDITATION UNDER CERTIFICATE NUMBER: 3212.01

This report must not be used by the client to claim product certification, approval, or endorsement by A2LA, NIST, or any agency of the Federal Government.

Tested by:

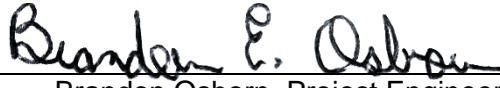
Brandon Osborn, Project Engineer

Reviewed by:

Jeremy Pickens, RF Lab Manager

Remarks: This report details the results of the testing carried out on one sample, the results contained in this test report do not relate to other samples of the same product. The manufacturer should ensure that all products in series production are in conformity with the product sample detailed in this report.

This document is issued by the Company under its General Conditions of Service accessible at <http://www.sgs.com/en/Terms-and-Conditions.aspx>. Attention is drawn to the limitation of liability, indemnification and jurisdiction issues defined therein.

Any holder of this document is advised that information contained hereon reflects the Company's findings at the time of its intervention only and within the limits of Client's instructions, if any. The Company's sole responsibility is to its Client and this document does not exonerate parties to a transaction from exercising all their rights and obligations under the transaction documents. Any unauthorized alteration, forgery or falsification of the content or appearance of this document is unlawful, and offenders may be prosecuted to the fullest extent of the law.

Table of Contents

1	SUMMARY OF TEST RESULTS	3
1.1	MODIFICATIONS REQUIRED TO COMPLIANCE.....	3
2	GENERAL INFORMATION	4
2.1	CLIENT INFORMATION.....	4
2.2	TEST LABORATORY.....	4
2.3	GENERAL INFORMATION OF EUT.....	4
2.4	OPERATING MODES AND CONDITIONS.....	4
2.5	EUT CONNECTION BLOCK DIAGRAM.....	5
2.6	SYSTEM CONFIGURATIONS.....	5
3	RADIATED SPURIOUS EMISSIONS	6
3.1	TEST RESULT.....	6
3.2	TEST METHOD.....	6
3.3	TEST SITE.....	6
3.4	TEST EQUIPMENT.....	7
3.5	TEST SETUP PHOTOGRAPHS.....	8
3.6	TEST DATA 30-1000MHZ.....	9
3.7	TEST DATA ABOVE 1GHZ.....	23
4	REVISION HISTORY	45

1 Summary of Test Results

Reference Sections		Test Description	Test Condition	Test Result
FCC	IC			
2.1046	RSS-GEN (6.12)	Conducted Output Power	Conducted	(see Note 1)
24.232(d) 27.50(d)(5)	RSS-130 (4.6.1) RSS-132 (5.4) RSS-133 (6.4) RSS-139 (6.5)	Peak-to-Average Ratio		(see Note 1)
22.917(b) 24.238(b) 27.53(h)(3)	RSS-GEN (6.7) RSS-133 (2.3)	Occupied Bandwidth Emission Bandwidth		(see Note 1)
22.917 24.238 27.53(c) 27.53(g) 27.53(h)	RSS-130 (4.7) RSS-132 (5.5) RSS-133 (6.5) RSS-139 (6.6)	Band Edge / Conducted Spurious Emissions		(see Note 1)
22.913(a)(5) 27.50(b)(9) 27.50(c)(9)	RSS-130 (4.6.3)	Effective Radiated Power		(see Note 1)
24.232(c) 27.50(d)(4)	RSS-132 (5.4) RSS-133 (6.4) RSS-139 (6.5)	Effective Isotropic Radiated Power	Radiated	(see Note 1)
22.917 24.238 27.53(c) 27.53(g) 27.53(h)	RSS-GEN (6.13) RSS-130 (4.7) RSS-132 (5.5) RSS-133 (6.5) RSS-139 (6.6)	Radiated Spurious Emissions		Compliant
22.355 24.235 27.54	RSS-GEN (6.11) RSS-130 (4.5) RSS-132 (5.3) RSS-133 (6.3) RSS-139 (6.4)	Frequency Stability		Conducted

1) Per KDB 996369 D04 Module Integration v1.01, only Radiated Spurious Emissions is required.
 Sample contains FCC ID: XMR2020BG95M1.

1.1 Modifications Required to Compliance

None

2 General Information

2.1 Client Information

Name: Mueller Systems, LLC.
 Address: 1200 Abernathy Rd NE, Suite 1200
 City, State, Zip, Country: Atlanta, GA 30328, USA

2.2 Test Laboratory

Name: SGS North America, Inc.
 Address: 620 Old Peachtree Road NW, Suite 100
 City, State, Zip, Country: Suwanee, GA 30024, USA

Accrediting Body: A2LA
 Type of lab: Testing Laboratory
 Certificate Number: 3212.01

2.3 General Information of EUT

Equipment Under Test: Smart Hydrant with BG95 4G LTE Module
 Model Number: Smart Hydrant
 Serial Number: Not provided

Contains FCC ID: XMR202005BG95M5
 Contains IC ID: 10224A-2020BG95M5
 Tx Frequency Range: 1850 – 1910 MHz (LTE Band 2)
 1710 – 1755 MHz (LTE Band 4)
 824 – 849 MHz (LTE Band 5)
 699 – 716 MHz (LTE Band 12)
 777 – 787 MHz (LTE Band 13)
 814 – 849 MHz (LTE Band 26)

Antenna Type/Gain: AVX Ethertronics P822601 chip type / 3.5-4.6dBi (698-2690MHz)

Radio Technology: LTE Cat M1
 Channel Bandwidth tested: 1.4 Mhz, 5 MHz
 RB allocation: 1 RB allocated, RB start = 0
 FCC Classification: PCS Licensed Transmitter (PCB)
 Rated Voltage: 3.6 Vdc
 Test Voltage: 3.6 Vdc
 Sample Received Date: 07 July 2021
 Dates of testing: 07 July 2021 to 05 August 2021; Retest on 27 September 2021

2.4 Operating Modes and Conditions

A Rohde & Schwarz test SIM was installed in the EUT. The EUT was powered by a fully charged battery pack. Once the modem established a cellular connection with a Rohde & Schwarz CMW 500 Wideband Radio Communication Tester. The CMW 500 was used to control the radio in the EUT to operate with maximum transmit (uplink) power in LTE Bands 2, 4, 12, 13 & 26. For LTE Cat M1 all using 1 Resource Block with an RB start position of 0. These were found to be the highest power channel configurations based on power measurements covering all configurations.

Band 26 supersedes Band 5 therefore Band 26 was tested.

2.5 EUT Connection Block Diagram

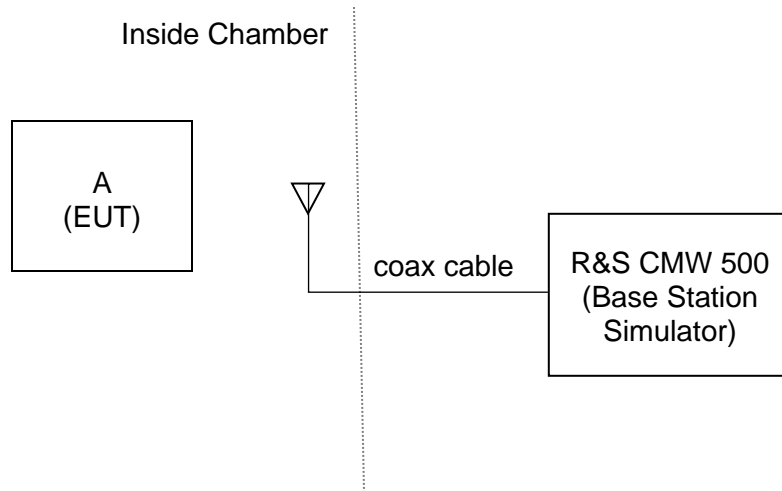

2.6 System Configurations

Device Reference	Manufacturer	Description	Model Number	Serial Number
A	Mueller Systems, LLC.	4G LTE Module (BG95) with a BLE radio	Smart Hydrant	NSN

3 Radiated Spurious Emissions

3.1 Test Result

Test Description	Basic Standards		Test Result
Radiated Spurious Emissions	FCC 22.917(a) FCC 24.238(a) FCC 27.53(c) FCC 27.53(f) FCC 27.53(g) FCC 27.53(h)	RSS-GEN (6.13) RSS-130 (4.7) RSS-132 (5.5) RSS-133 (6.5) RSS-139 (6.6)	Compliant

3.2 Test Method

The radiated power emanating from the EUT of the band edge (out-of-band) and spurious band emissions are measured by means of a calibrated spectrum analyzer. The spectrum is investigated from the lowest radio frequency signal generated in the equipment, without going below 9 kHz, up to at least the tenth harmonic of the highest fundamental frequency or to 40 GHz, whichever is lower. The power of any emissions outside the licensee's frequency band(s) of operation shall be attenuated below the transmitter power (P) measured in watts by at least $43 + 10 \log (P)$ dB.

The EUT was tested in all 3 orthogonal axes and the worst-case data is reported.

The measurement was oriented in both vertical and horizontal polarizations.

A radio link was established between the EUT and a Radio Communications Tester. The output power of the EUT was set to maximum value by using the maximum power setting on the Radio Communications Tester.

The measurements were performed at the middle channel of the lowest and highest band tested.

3.3 Test Site

10m Absorber Lined Shielded Enclosure (ALSE), Suwanee, GA
 3m Absorber Lined Shielded Enclosure (ALSE), Suwanee, GA

30-1000MHz

Environmental Conditions:

Temperature: 23 °C
 Relative Humidity: 52.8 %
 Atmospheric Pressure: 97.70 kPa

1-18GHz

Environmental Conditions:

Temperature: 22.7 °C
 Relative Humidity: 53 %
 Atmospheric Pressure: 97.74 kPa

3.4 Test Equipment

30-1000 MHz

Test End Date: 7-Jul-2021

Tester: ZH

Equipment	Model	Manufacturer	Asset Number	Cal Due Date
ANTENNA, BILOG	JB6	SUNOL	B079689	5-Nov-2022
RF Cable Nm to Nm, 0.01-18GHz	90-195-354	TELEDYNE STORM MICROWAVE	20120	17-Feb-2022
RF Cable Nm to Nf, 0.01-18GHz	90-213-118	TELEDYNE STORM MICROWAVE	20117	17-Feb-2022
RF CABLE, Nm to Nm.	90-195-157	TELEDYNE STORM MICROWAVE	21019	26-Mar-2022
RF CABLE	104PE	HUBER & SUHNER	B079793	3-Sep-2021
LOW NOISE AMPLIFIER	ZKL-2+	Mini-Circuits	B079817	28-Sep-2021
EMI TEST RECEIVER	ESU40	ROHDE & SCHWARZ	B079629	21-Jun-2022
WIDEBAND RADIO COMMUNICATION TESTER	CMW500	ROHDE & SCHWARZ	B094874	17-Jan-2022

1-18 GHz

Test End Date: 8-Jul-2021

Tester: ZH

Equipment	Model	Manufacturer	Asset Number	Cal Due Date
ANTENNA, DRG HORN (MEDIUM)	3117	ETS Lindgren	B079699	15-Jul-2022
RF Cable Nm to Nm, 0.01-18GHz	90-195-354	TELEDYNE STORM MICROWAVE	20120	17-Feb-2022
RF CABLE	104PE	HUBER & SUHNER	B079793	3-Sep-2021
LOW NOISE AMPLIFIER	TS-PR18	ROHDE & SCHWARZ	15003	28-Oct-2021
WIDEBAND RADIO COMMUNICATION TESTER	CMW500	ROHDE & SCHWARZ	B094874	17-Jan-2022
EMI TEST RECEIVER	ESU40	ROHDE & SCHWARZ	B079629	21-Jun-2022

- Unless otherwise noted, equipment is on a 1-year calibration cycle.

3.5 Test Setup Photographs



3.6 Test Data 30-1000MHz

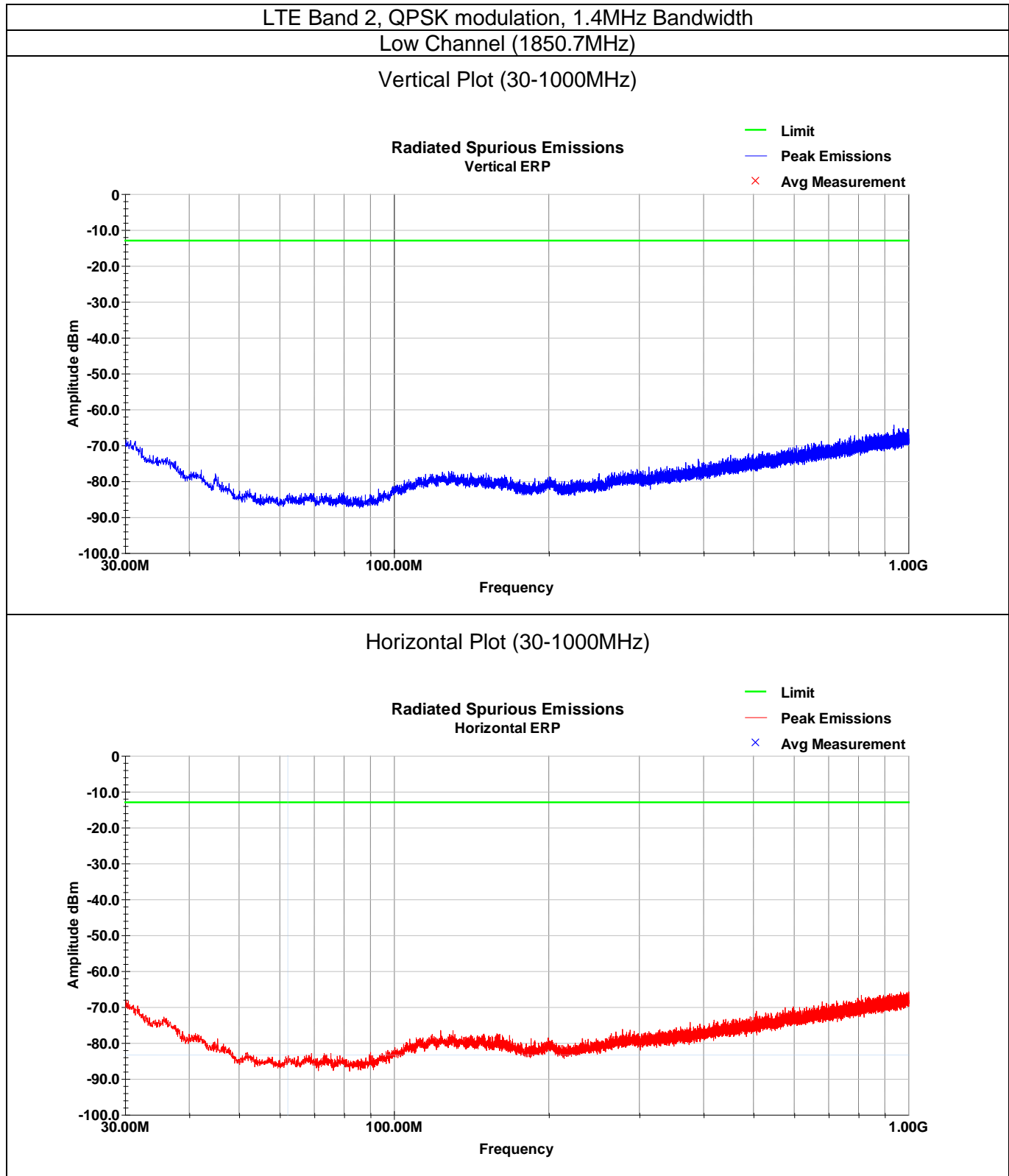

LTE Band 2, QPSK modulation, 1.4MHz Bandwidth

Mid Channel (1880MHz)

Vertical Plot (30-1000MHz)

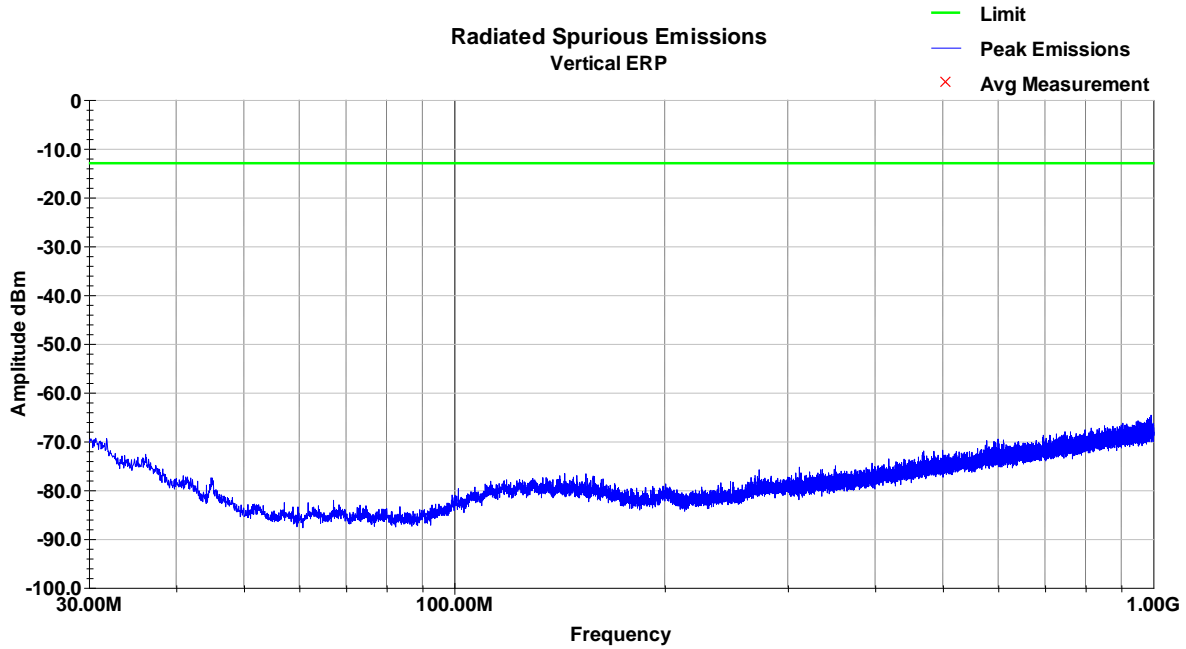

Horizontal Plot (30-1000MHz)

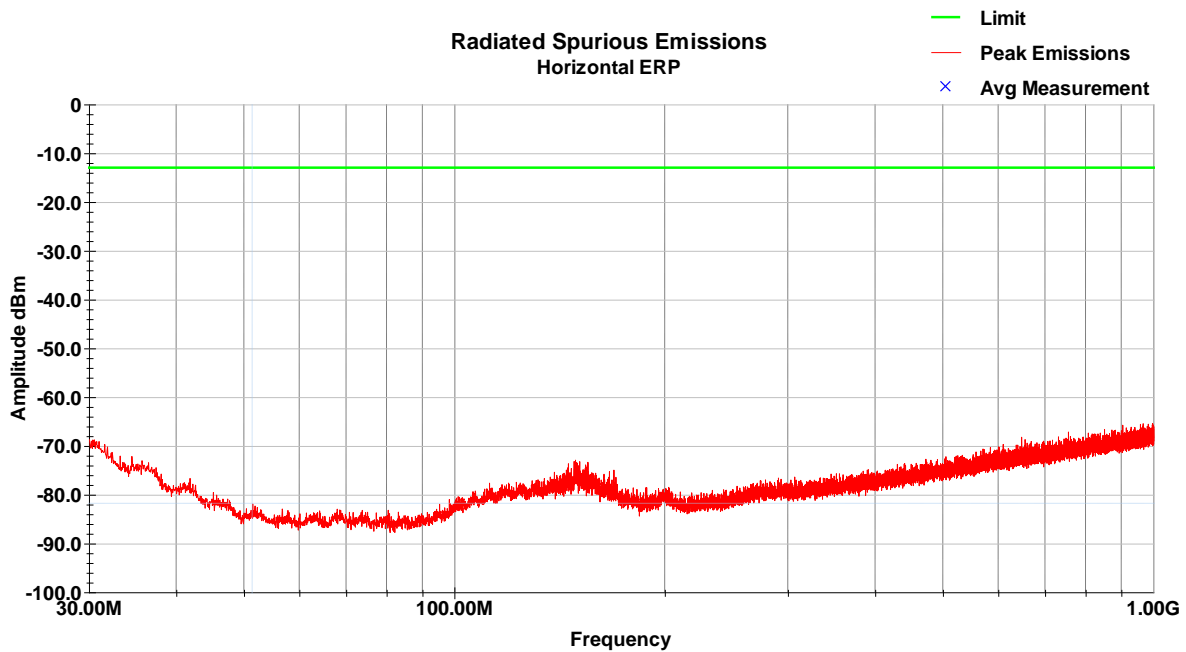

LTE Band 2, QPSK modulation, 1.4MHz Bandwidth

High Channel (1909.3MHz)

Vertical Plot (30-1000MHz)

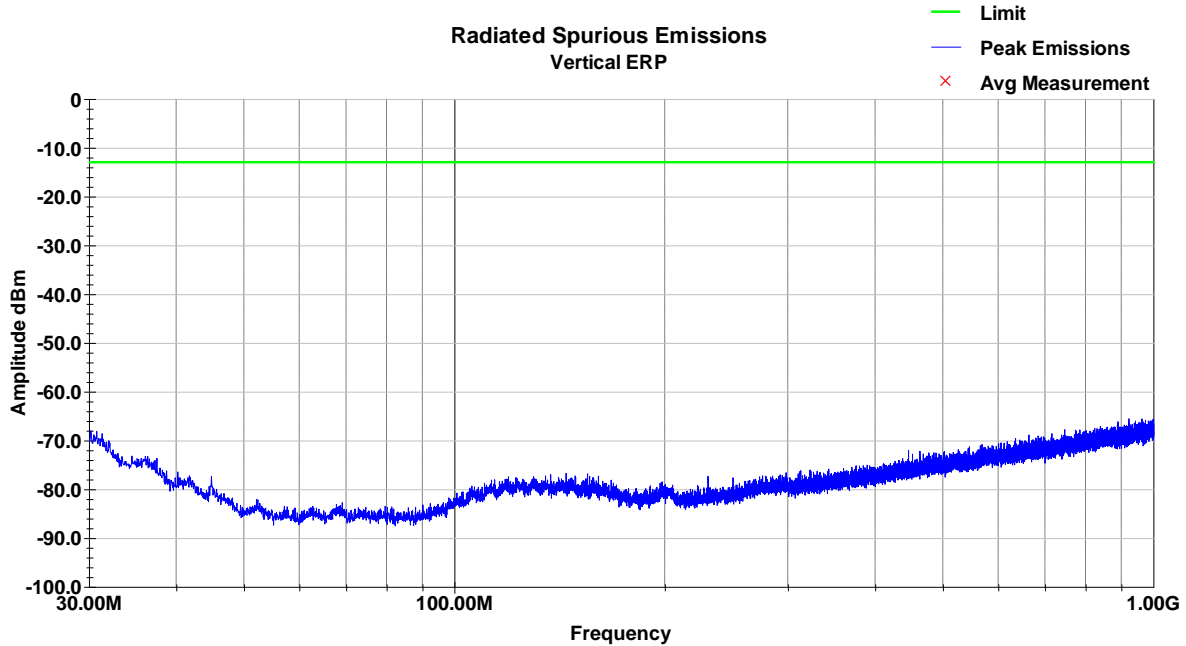

Horizontal Plot (30-1000MHz)

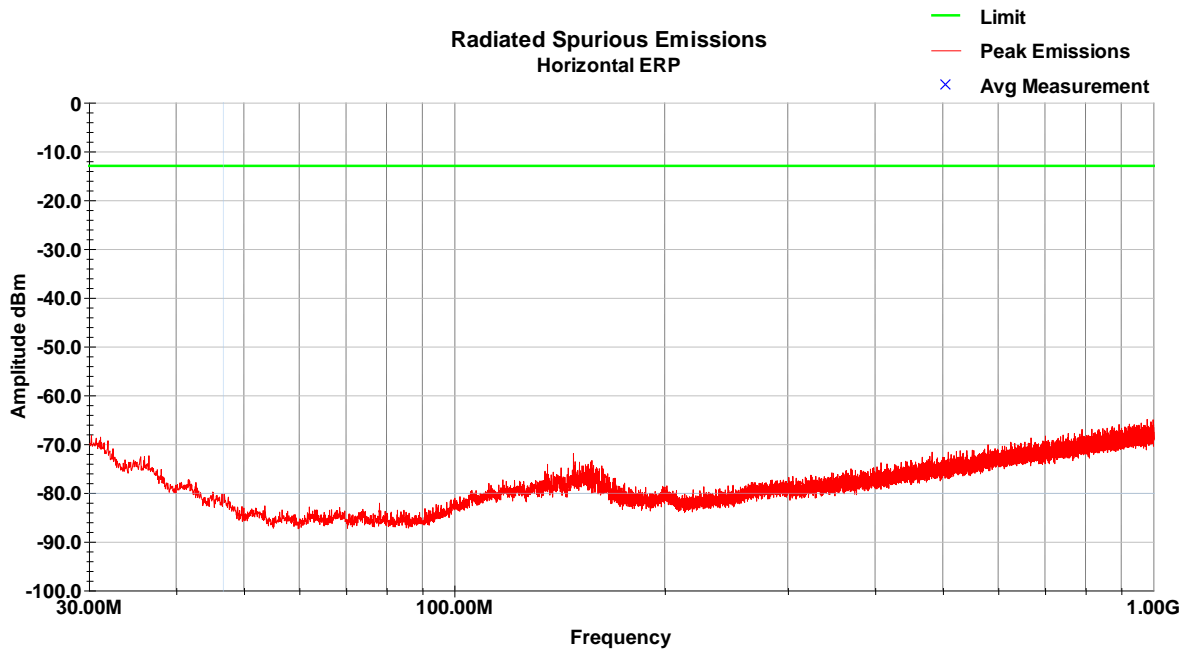

Found no emissions within 20dBm from limit.

LTE Band 4, QPSK modulation, 1.4MHz Bandwidth

Low channel (1710.7MHz)

Vertical Plot (30-1000MHz)

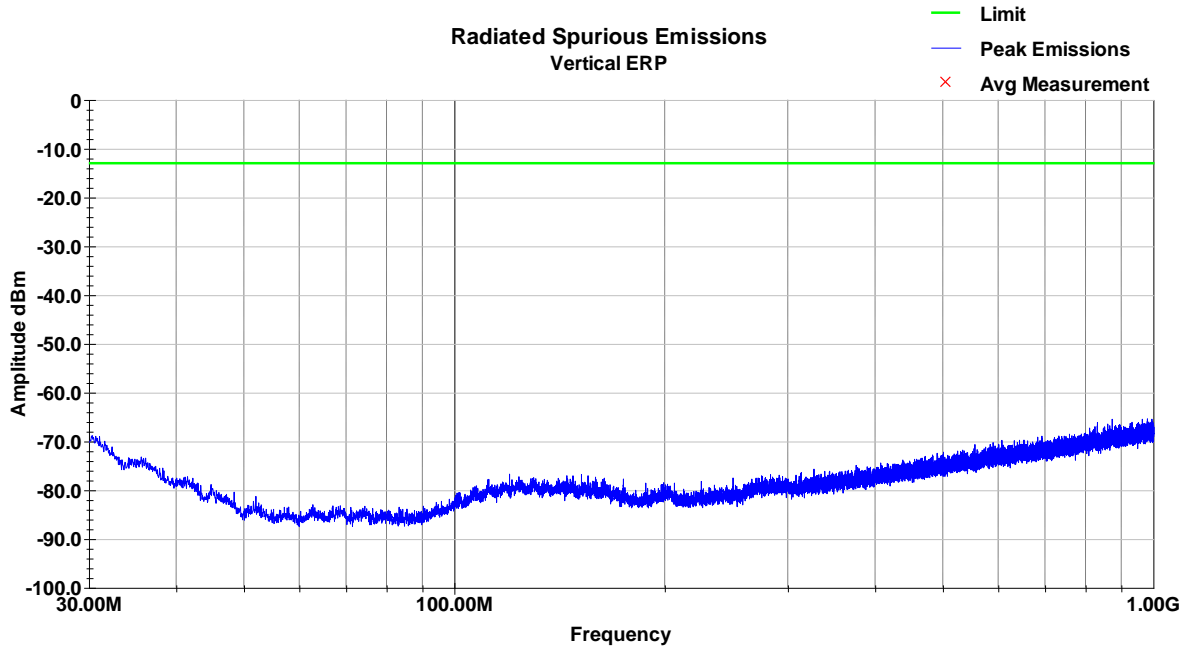

Horizontal Plot (30-1000MHz)

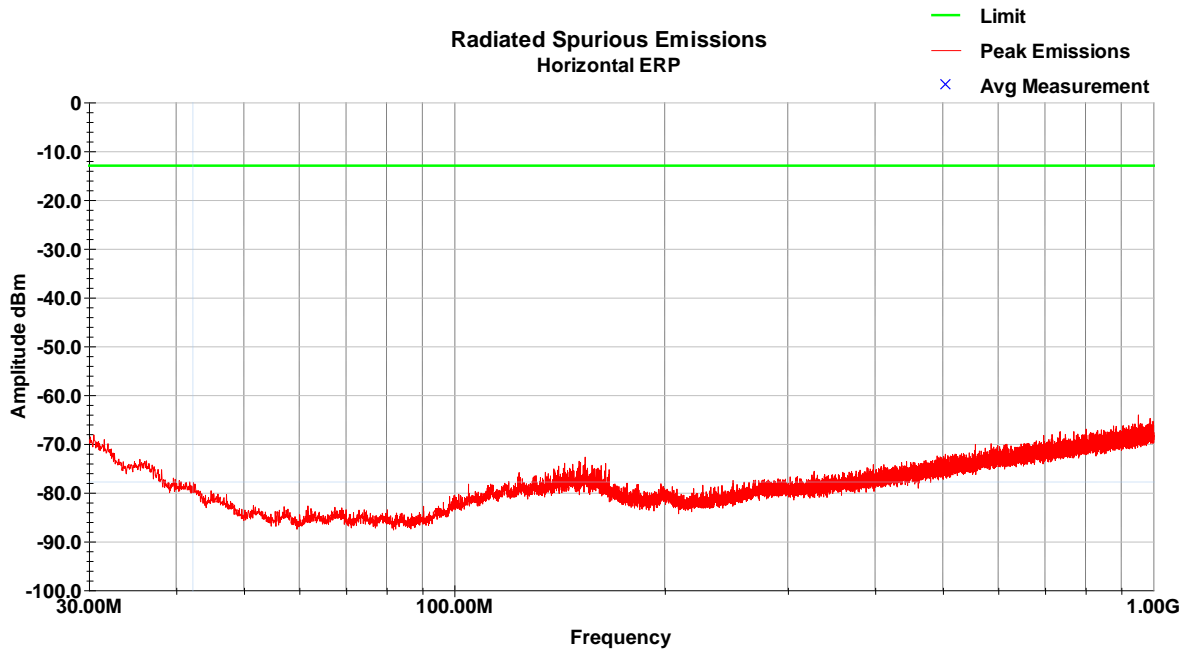

LTE Band 4, QPSK modulation, 1.4MHz Bandwidth

Mid channel (1732.5MHz)

Vertical Plot (30-1000MHz)

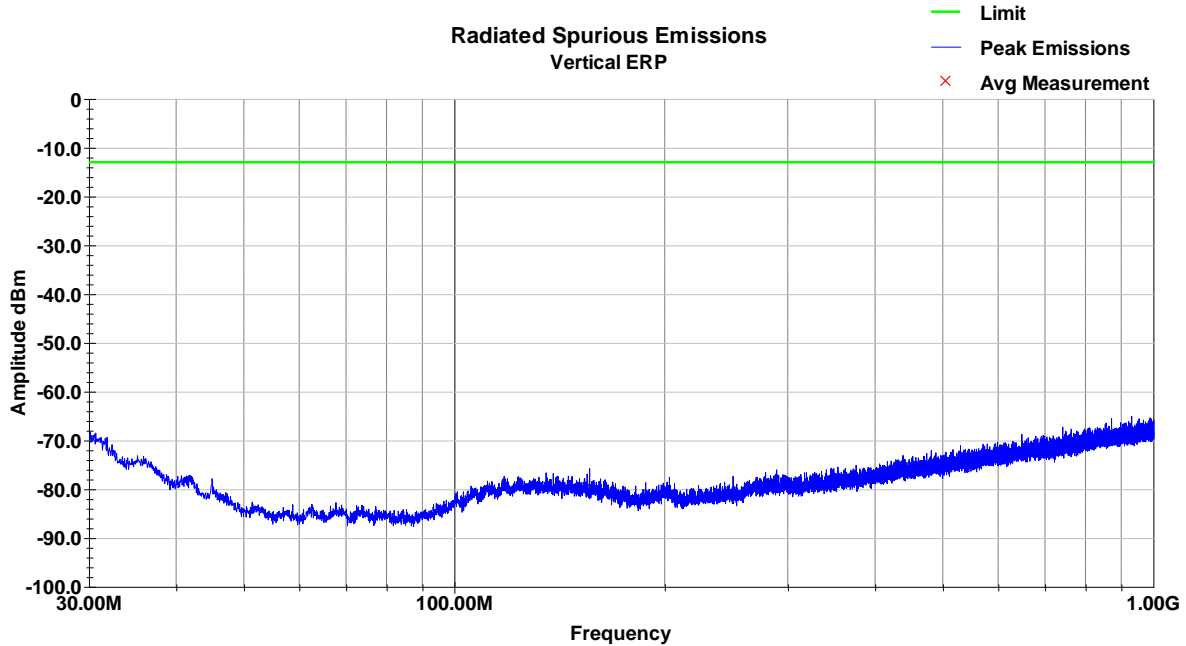

Horizontal Plot (30-1000MHz)

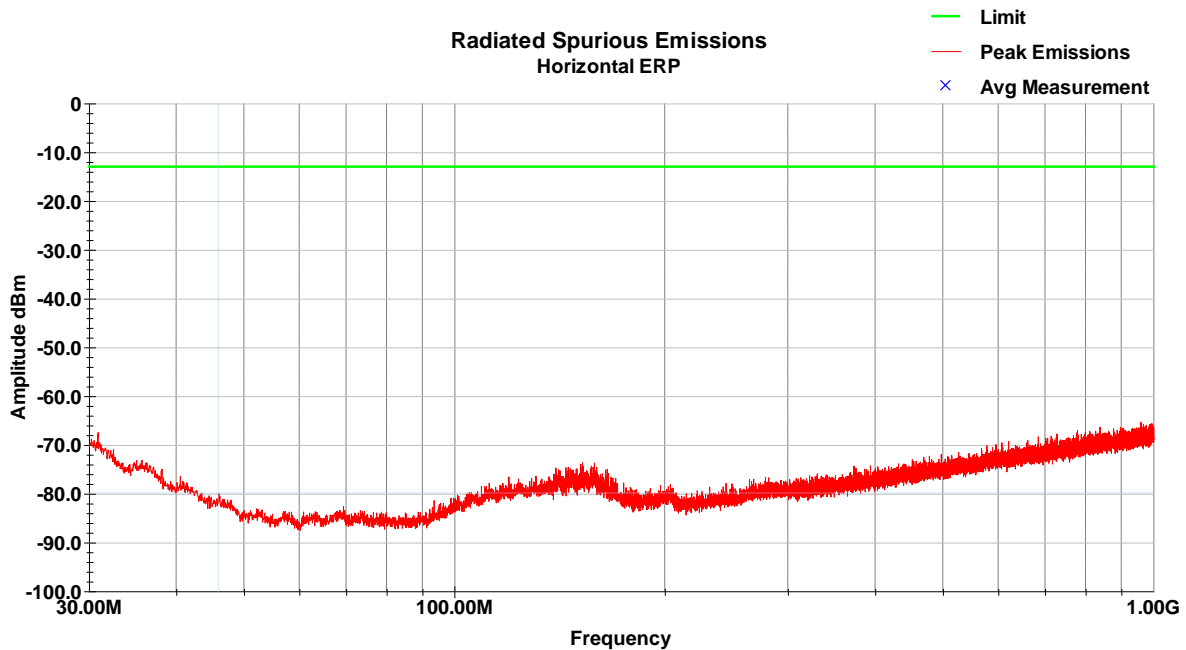

LTE Band 4, QPSK modulation, 1.4MHz Bandwidth

High channel (1754.3MHz)

Vertical Plot (30-1000MHz)

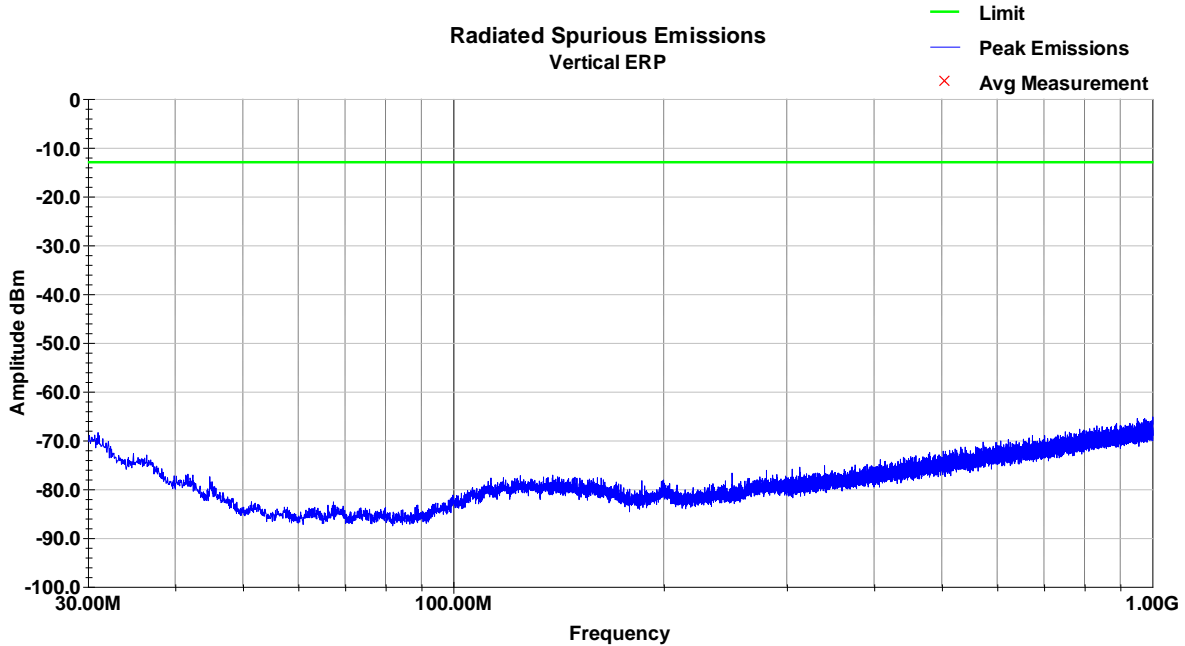

Horizontal Plot (30-1000MHz)

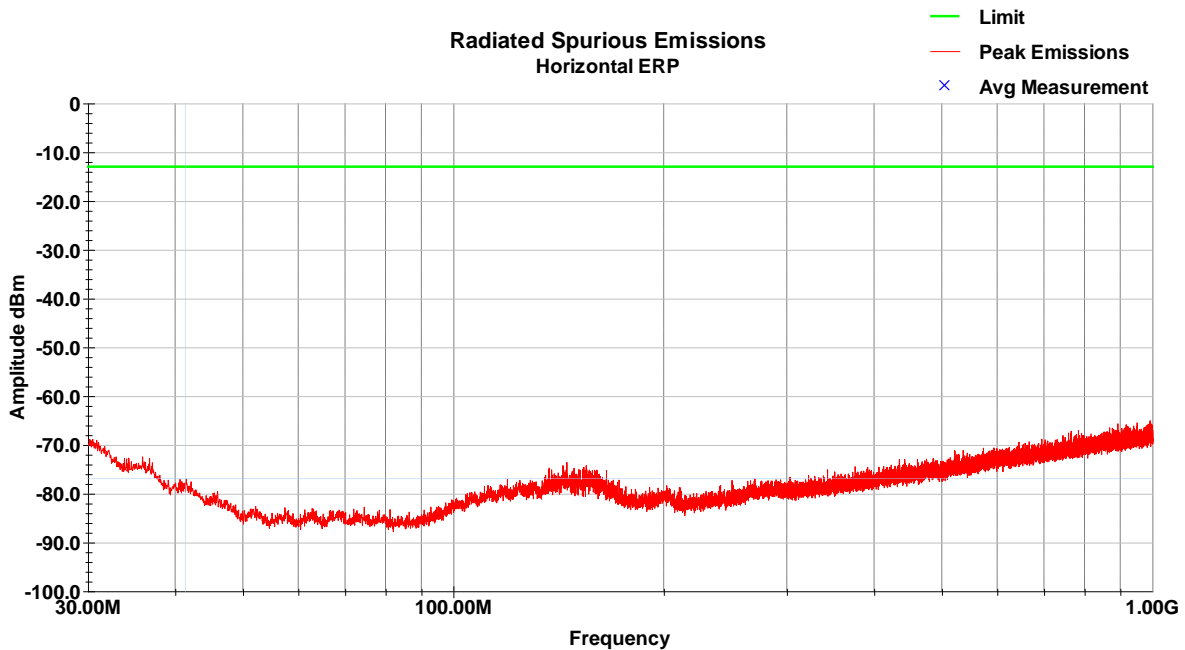

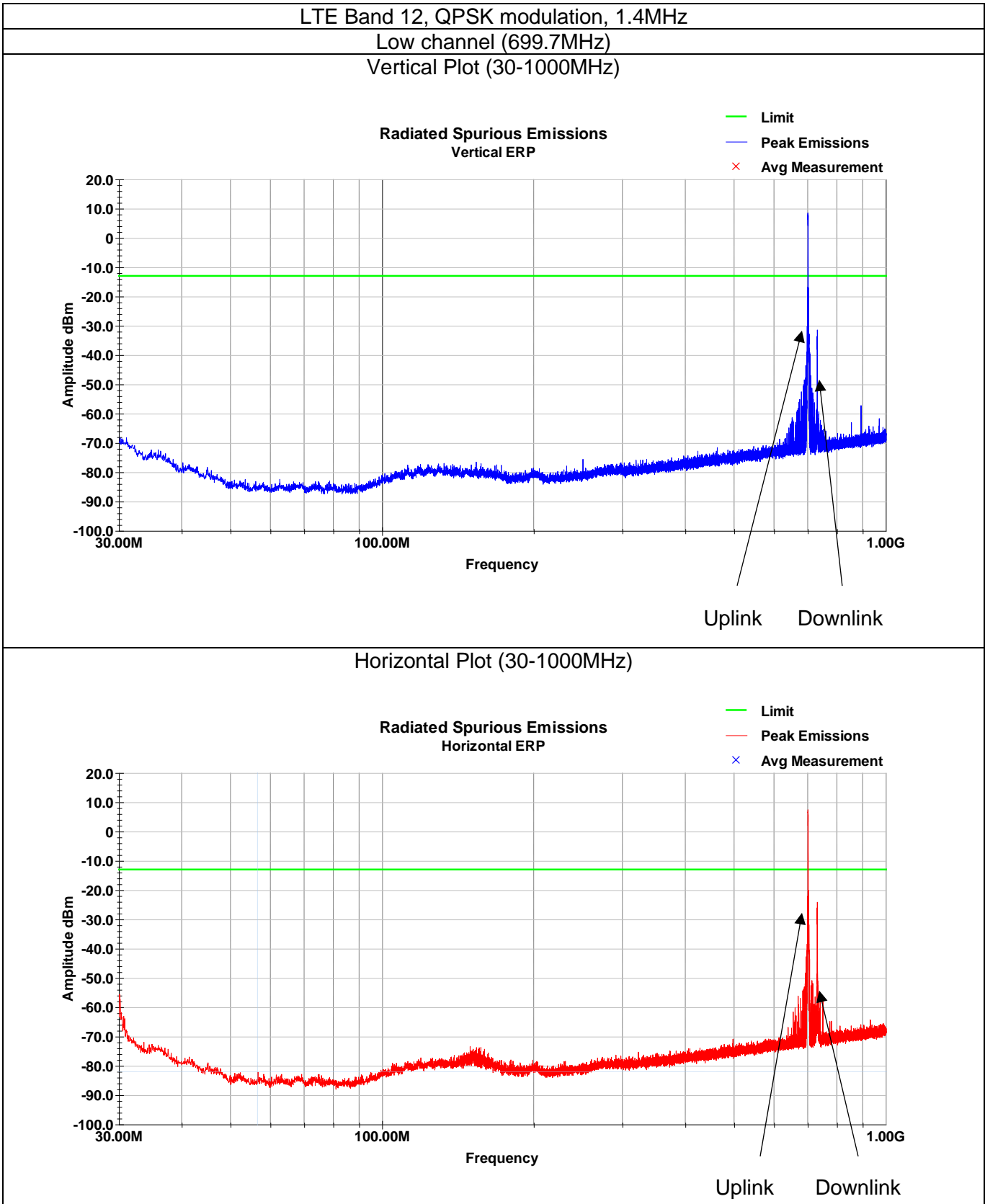

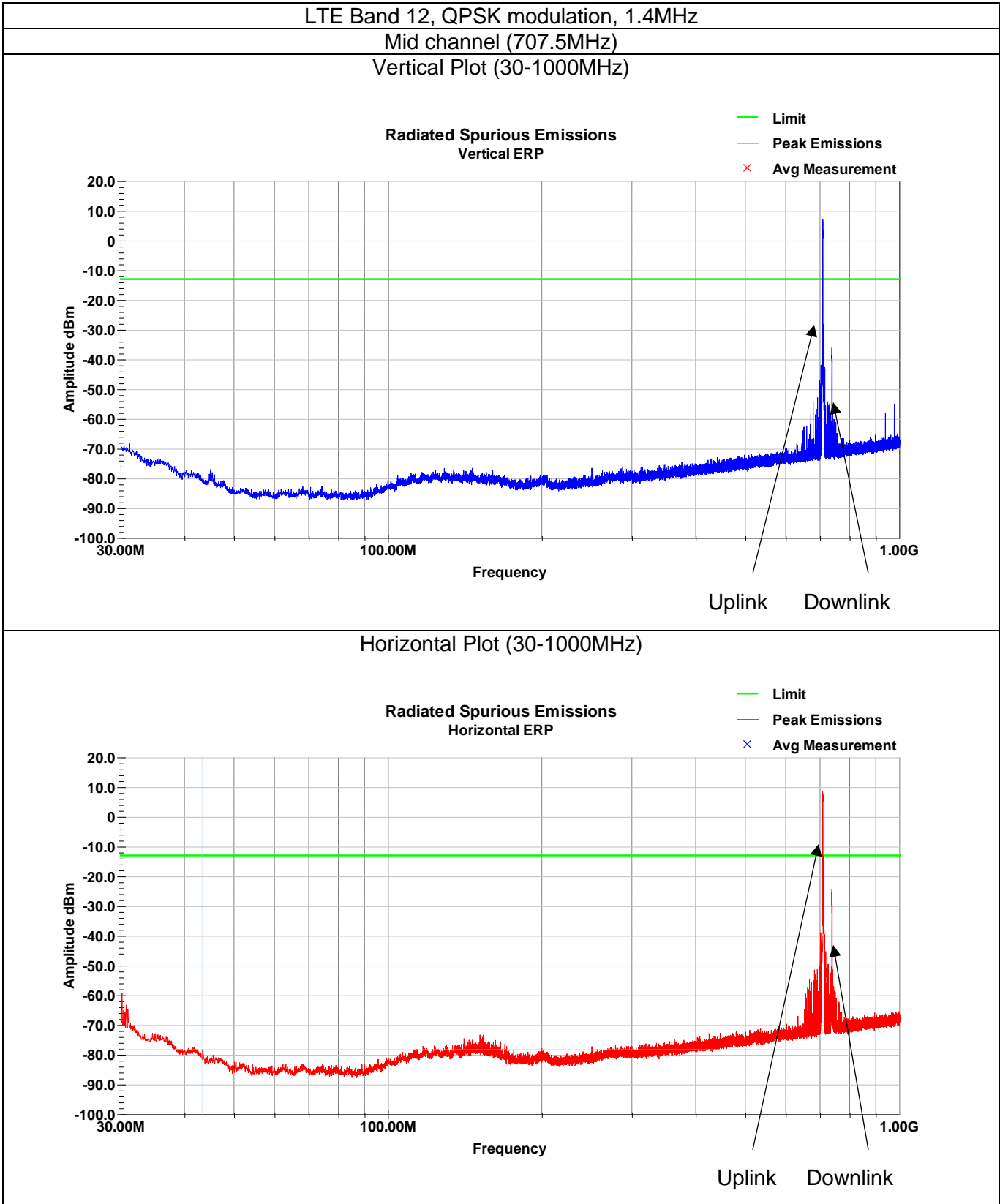

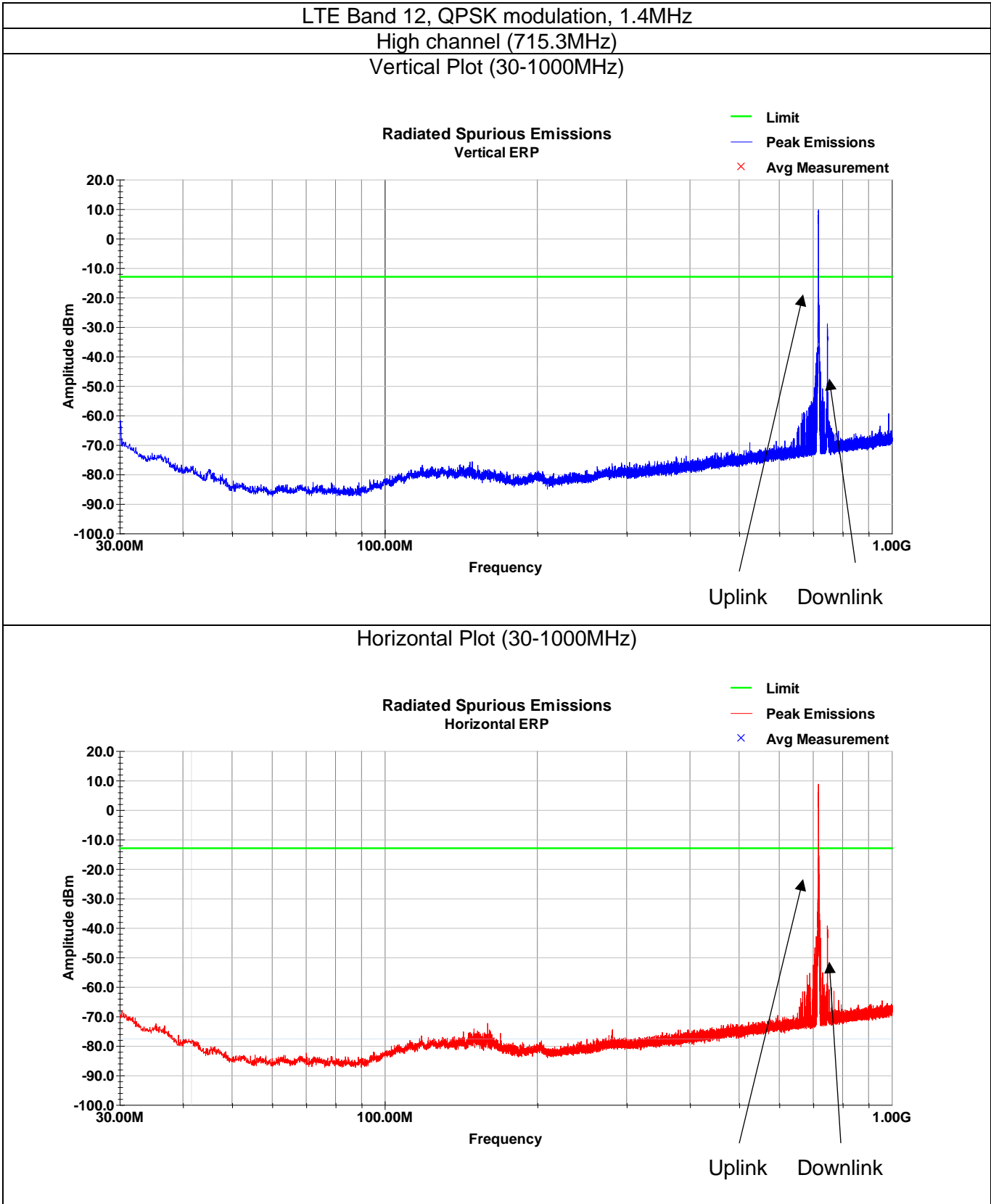

LTE Band 13, QPSK modulation, 5MHz

Low channel (779.5MHz)

Vertical Plot (30-1000MHz)

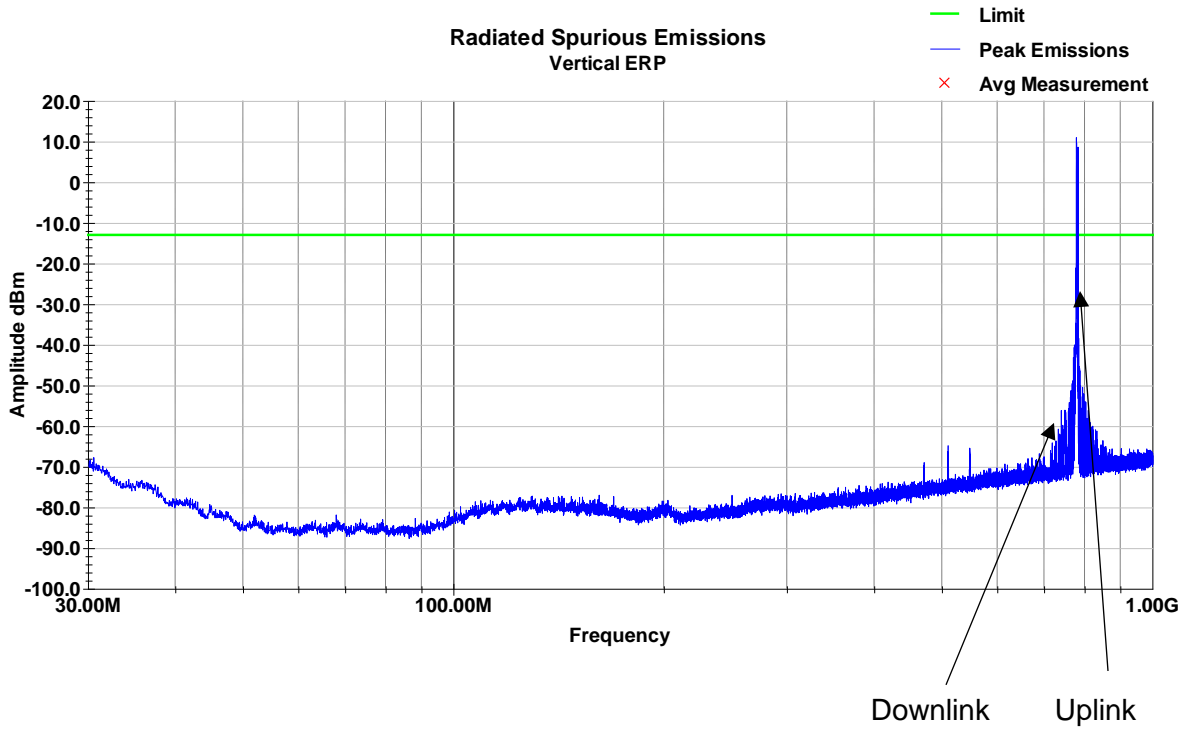

Horizontal Plot (30-1000MHz)

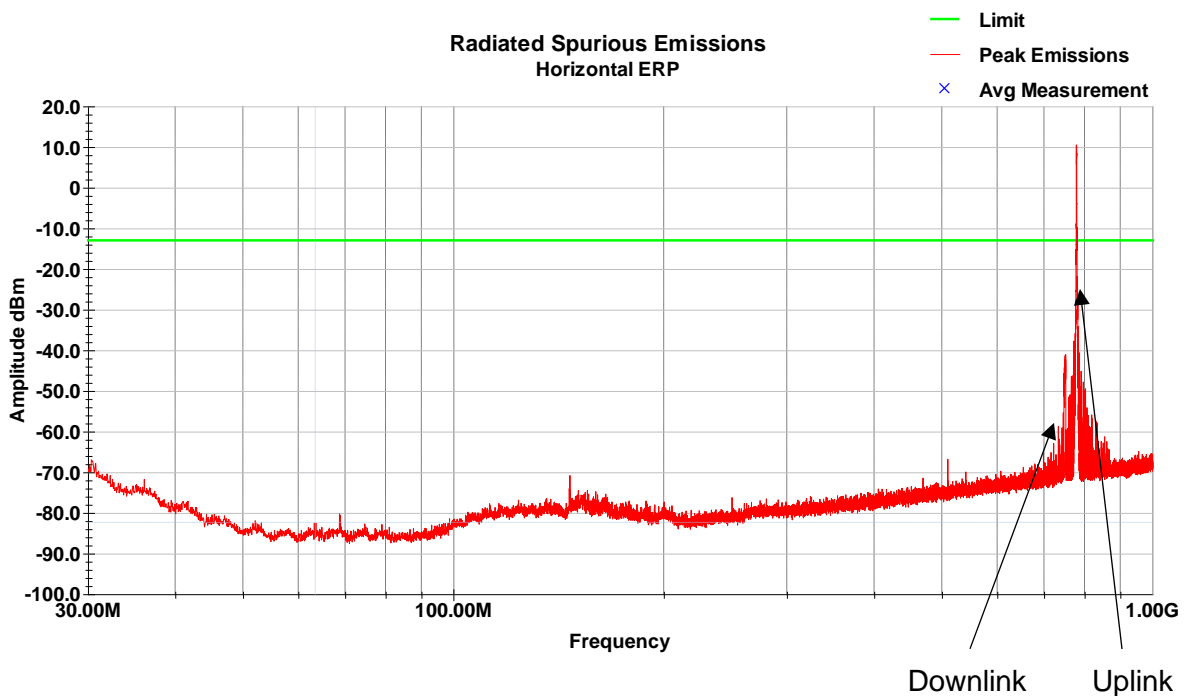

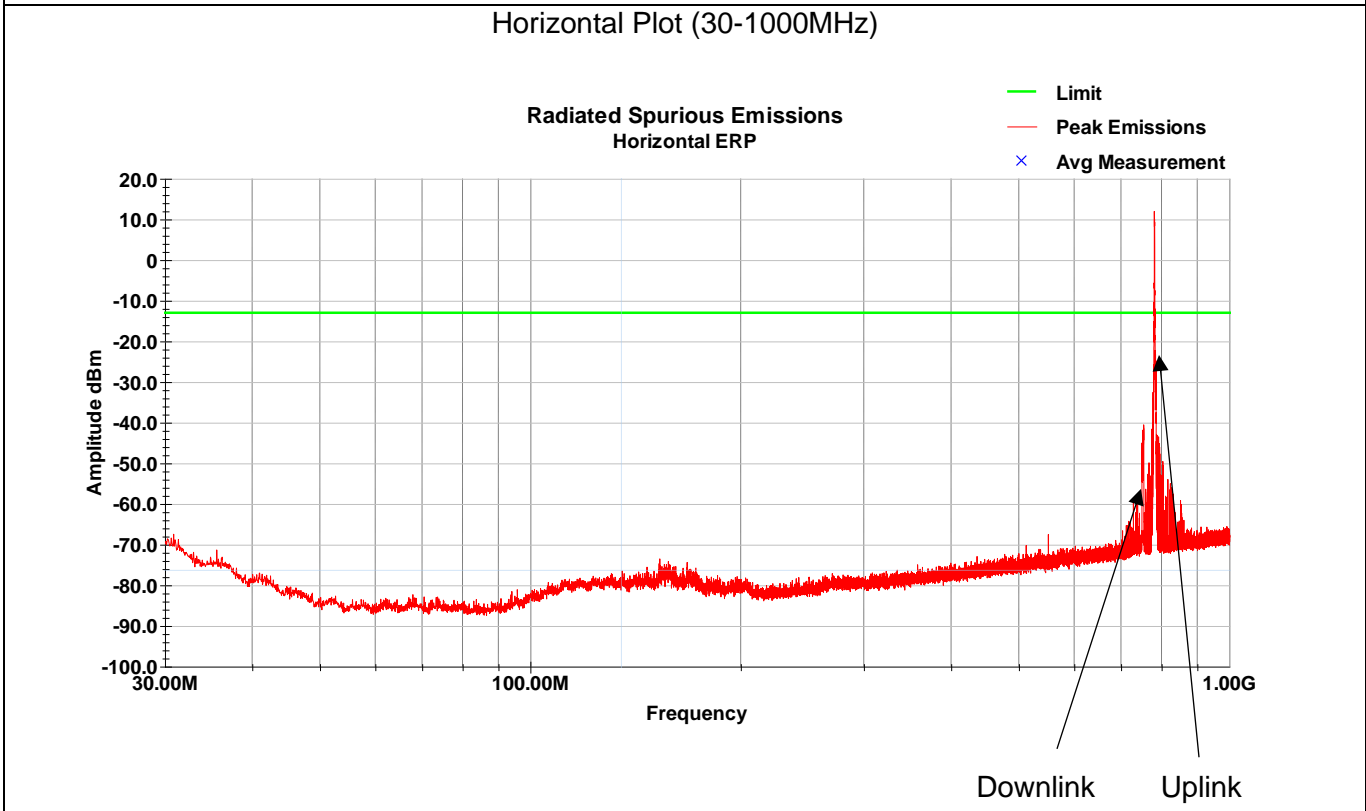
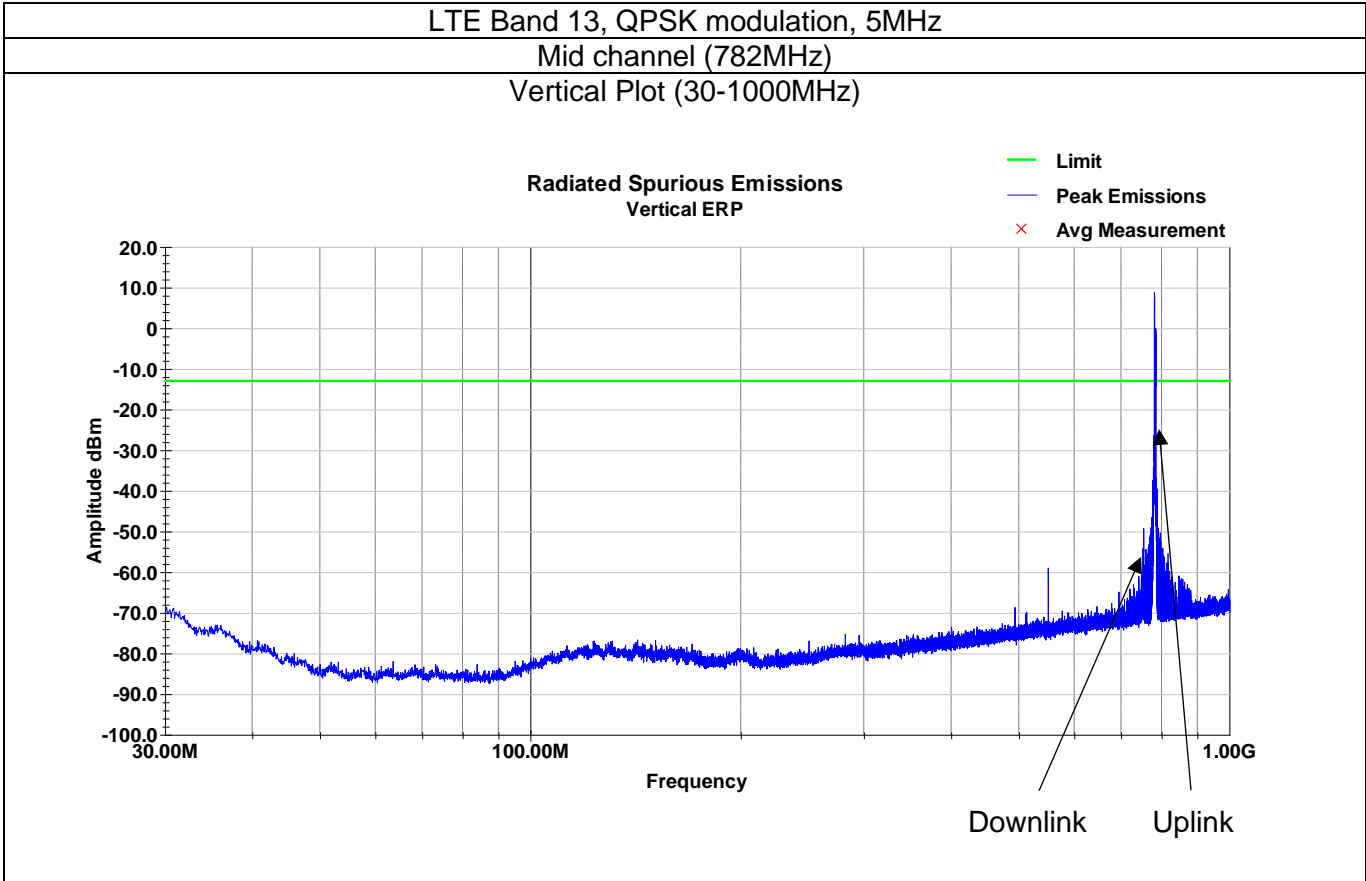

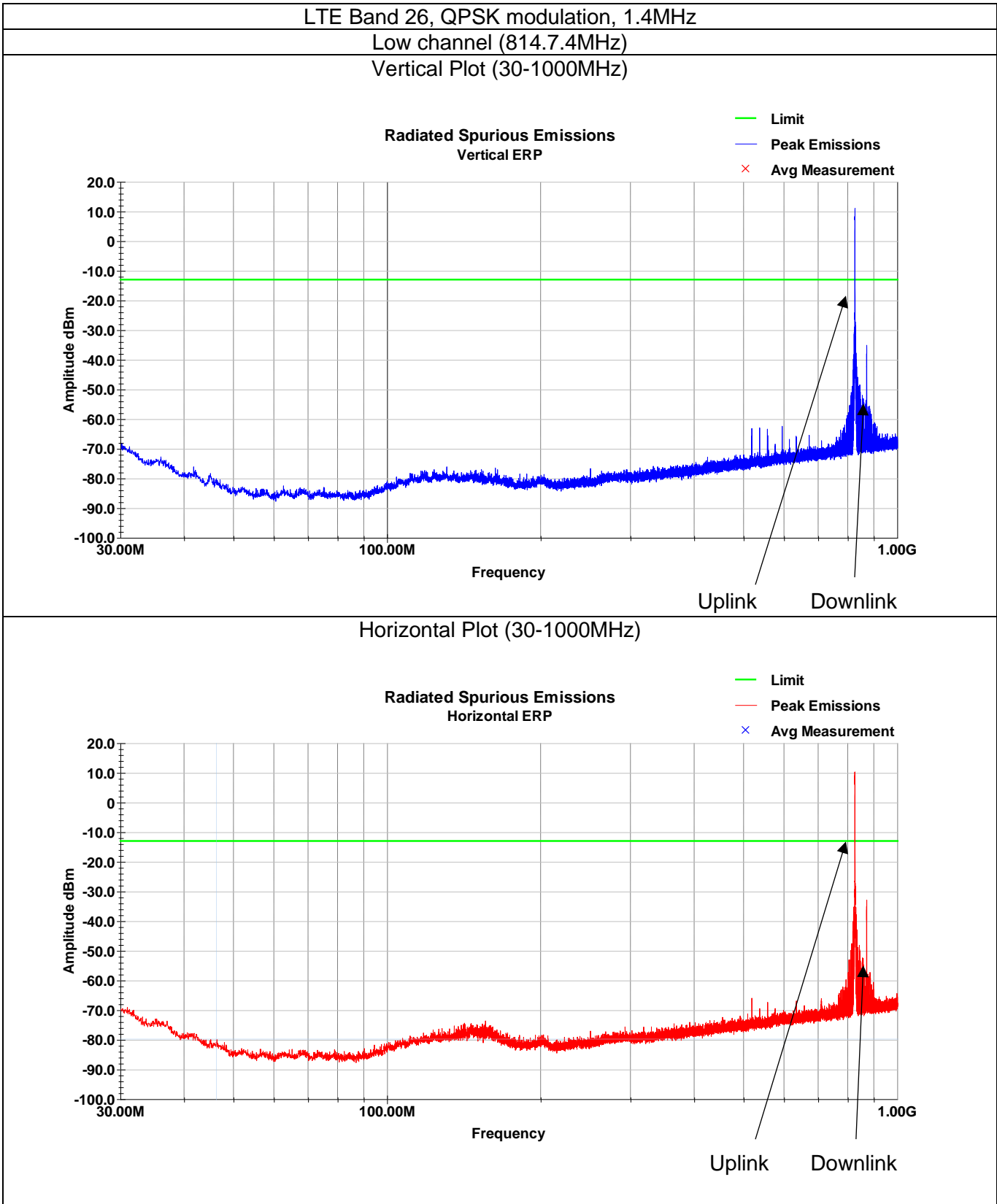

Found no emissions within 20dBm from limit.

LTE Band 26, QPSK modulation, 1.4MHz

Mid channel (836.5MHz)

Vertical Plot (30-1000MHz)

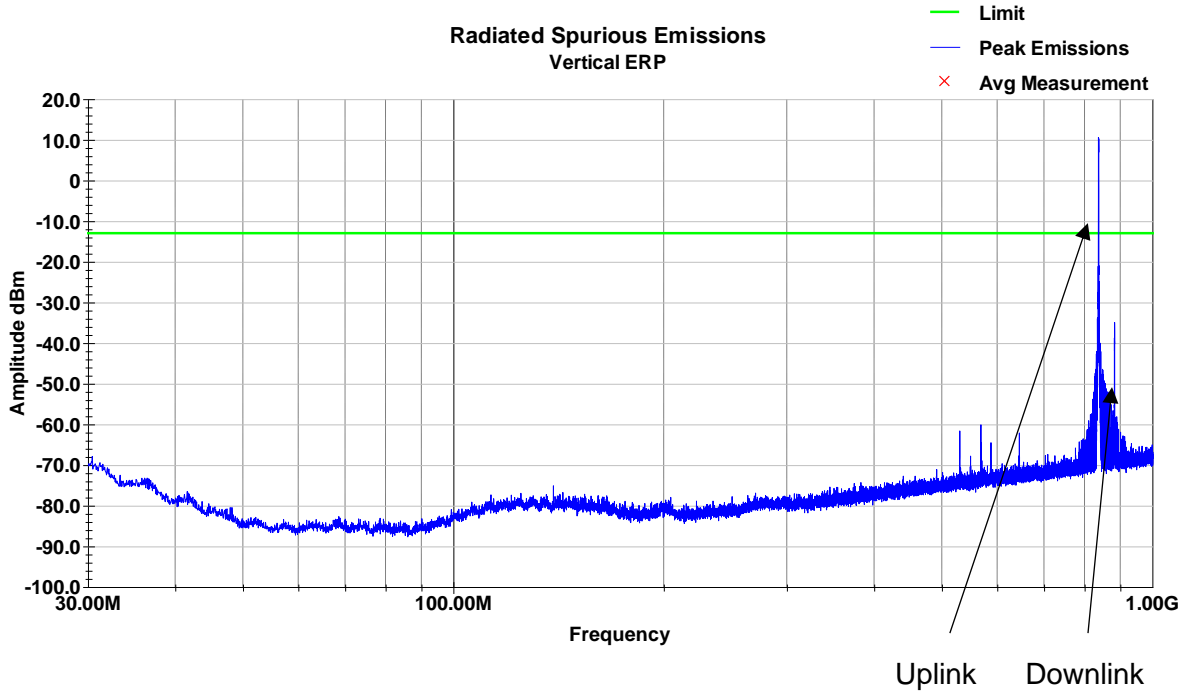

Horizontal Plot (30-1000MHz)

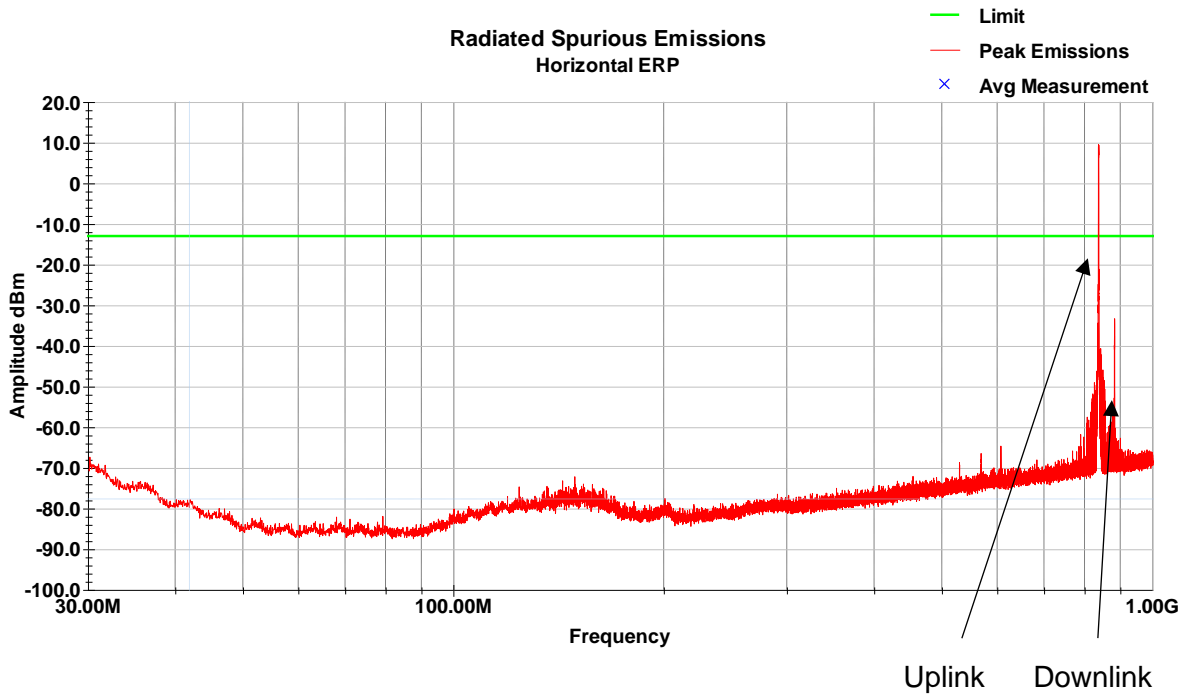

LTE Band 26, QPSK modulation, 1.4MHz

High channel (848.3MHz)

Vertical Plot (30-1000MHz)

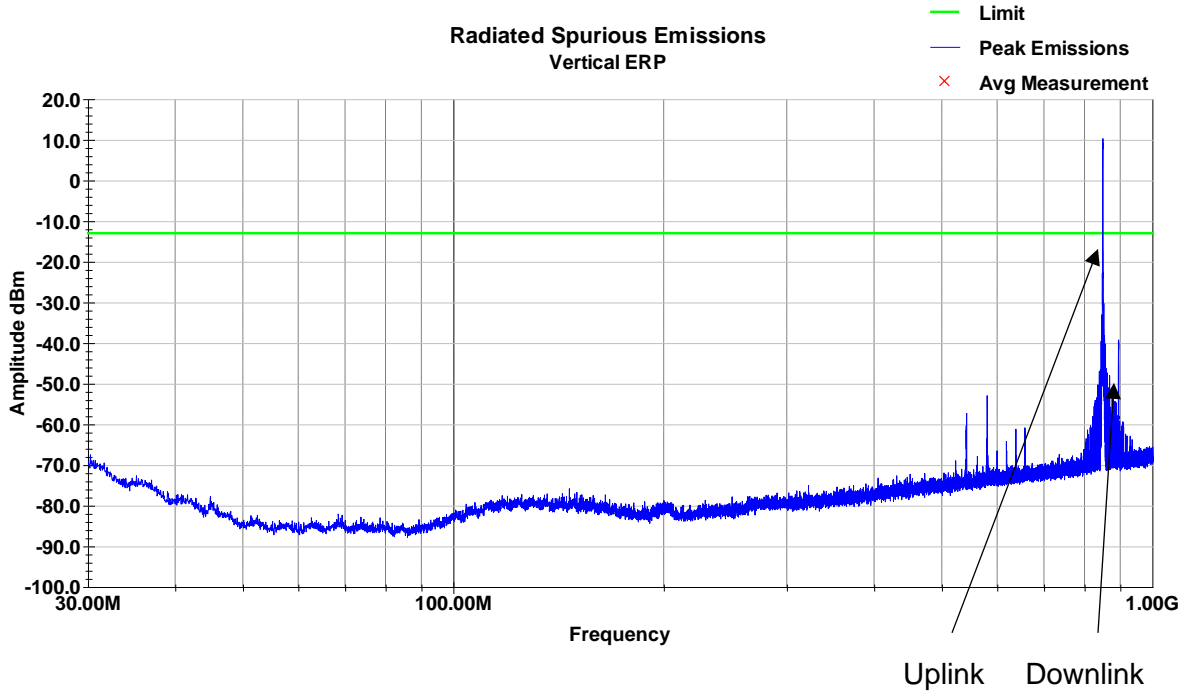

Horizontal Plot (30-1000MHz)

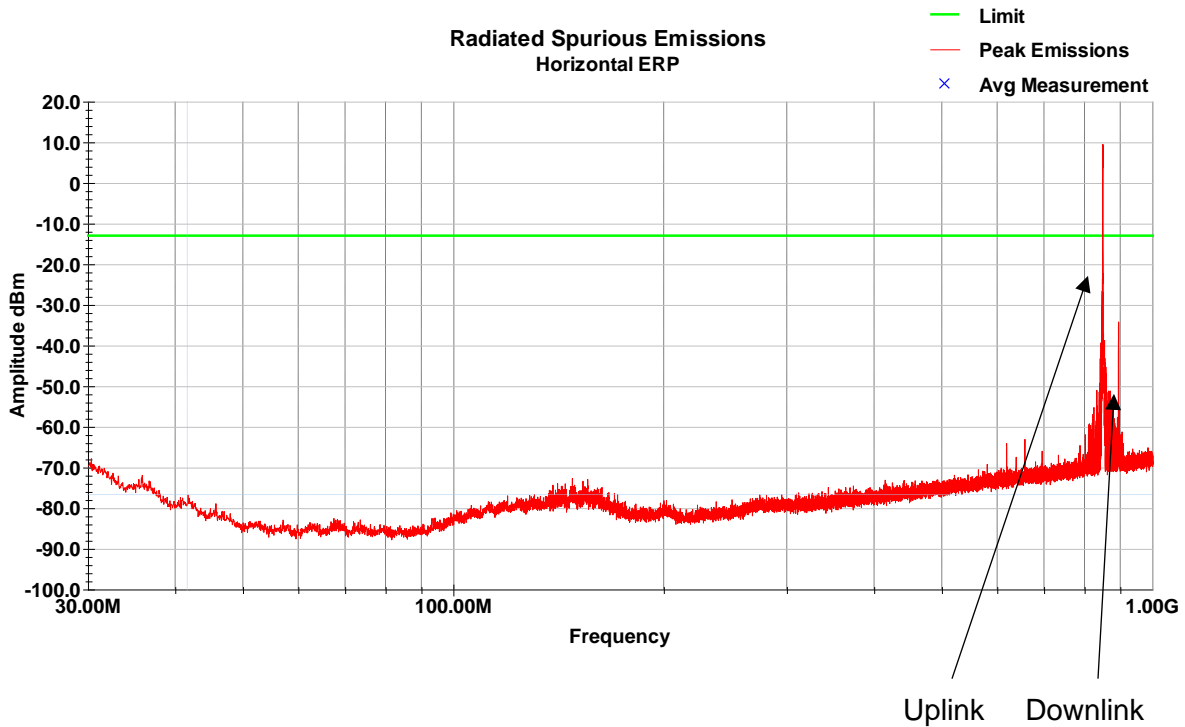

3.7 Test Data Above 1GHz

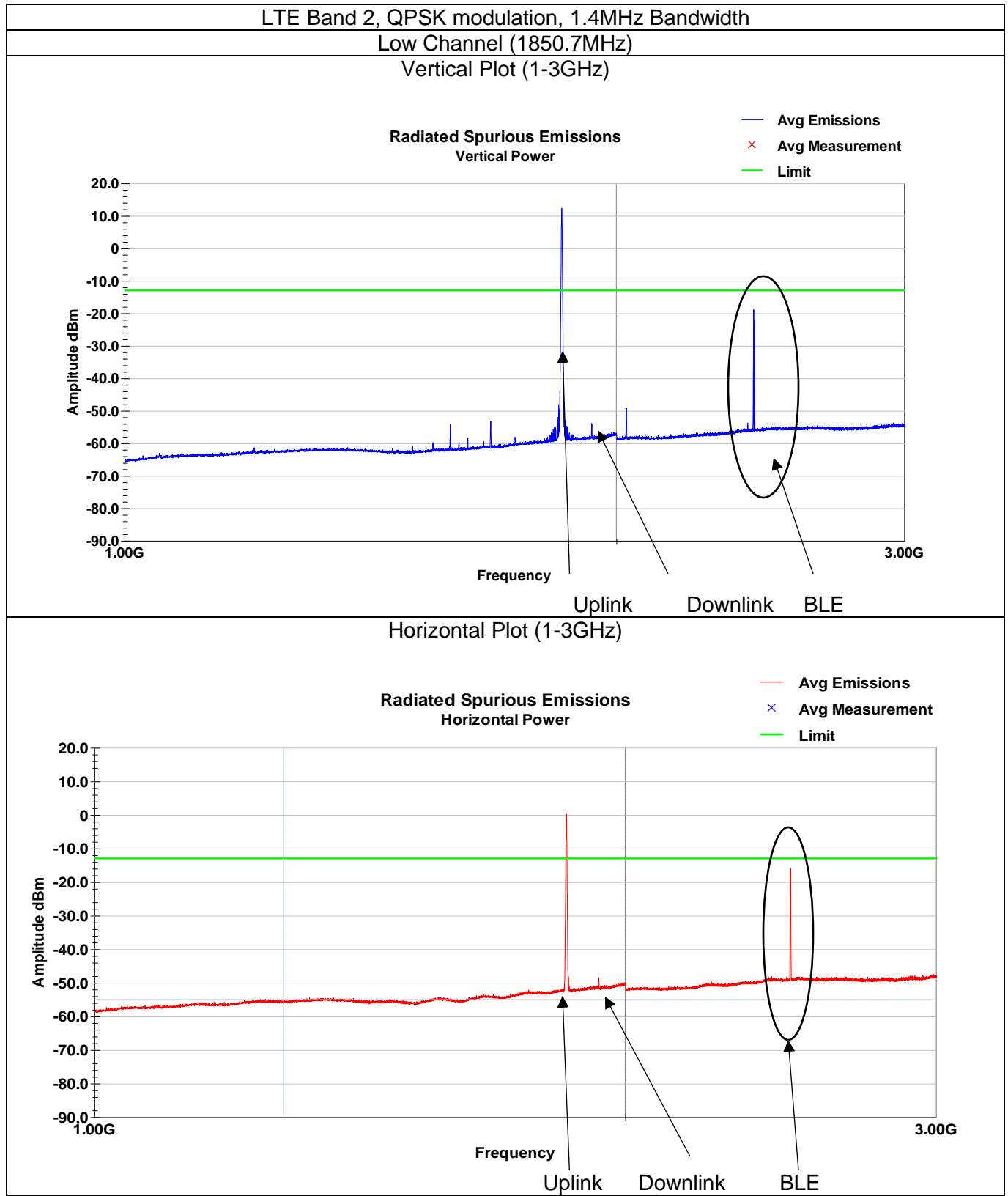

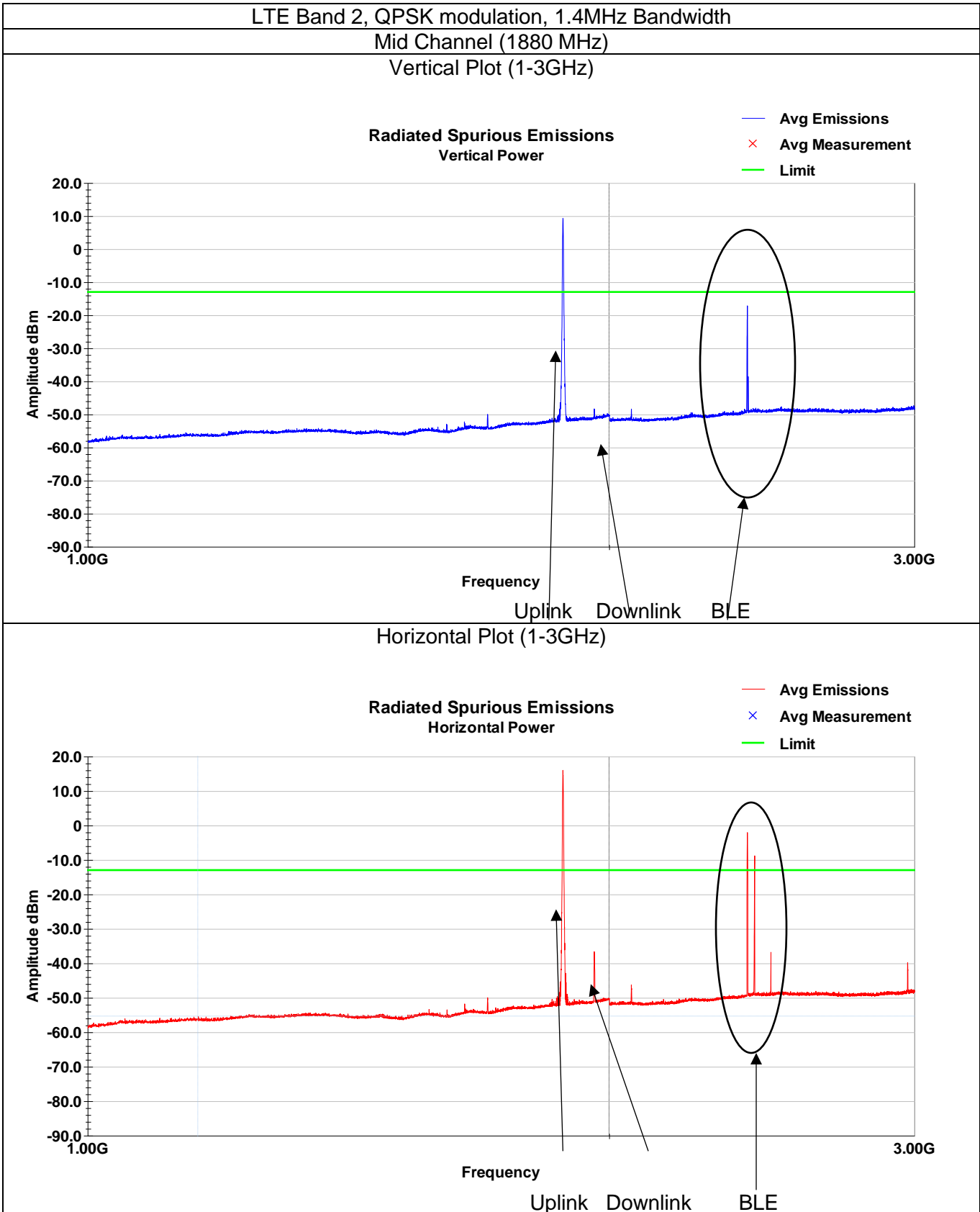

LTE Band 2, QPSK modulation, 1.4MHz Bandwidth

High Channel (1909.3 MHz)

Vertical Plot (1-3GHz)

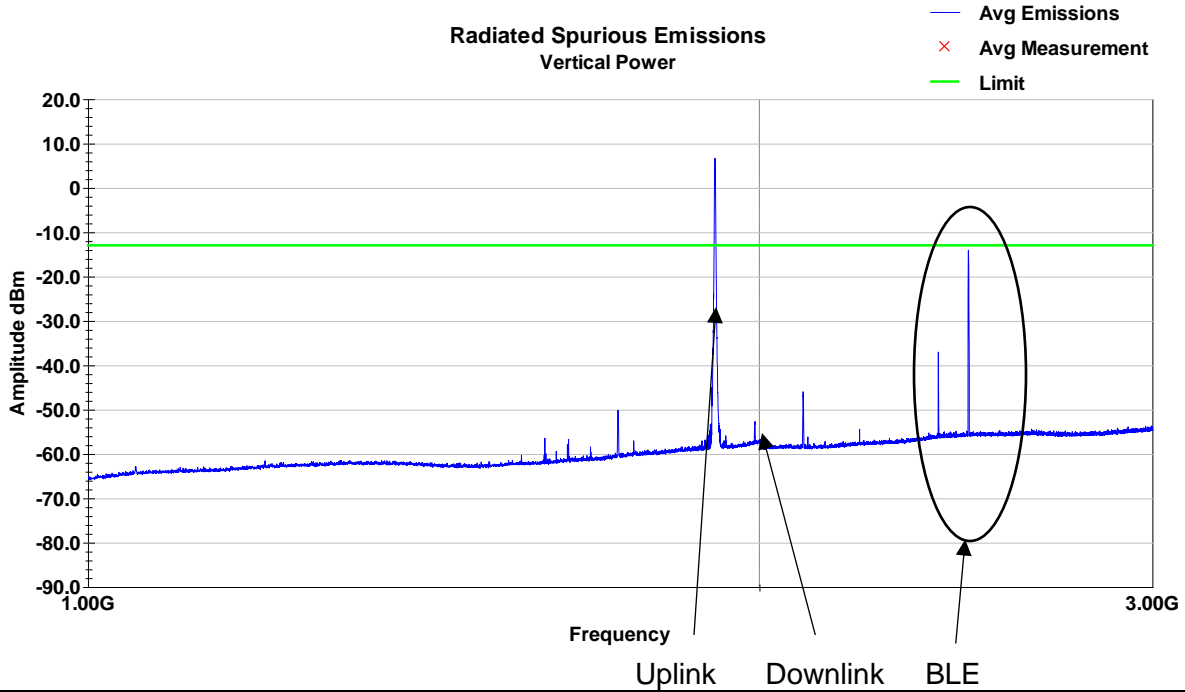

Horizontal Plot (1-3GHz)

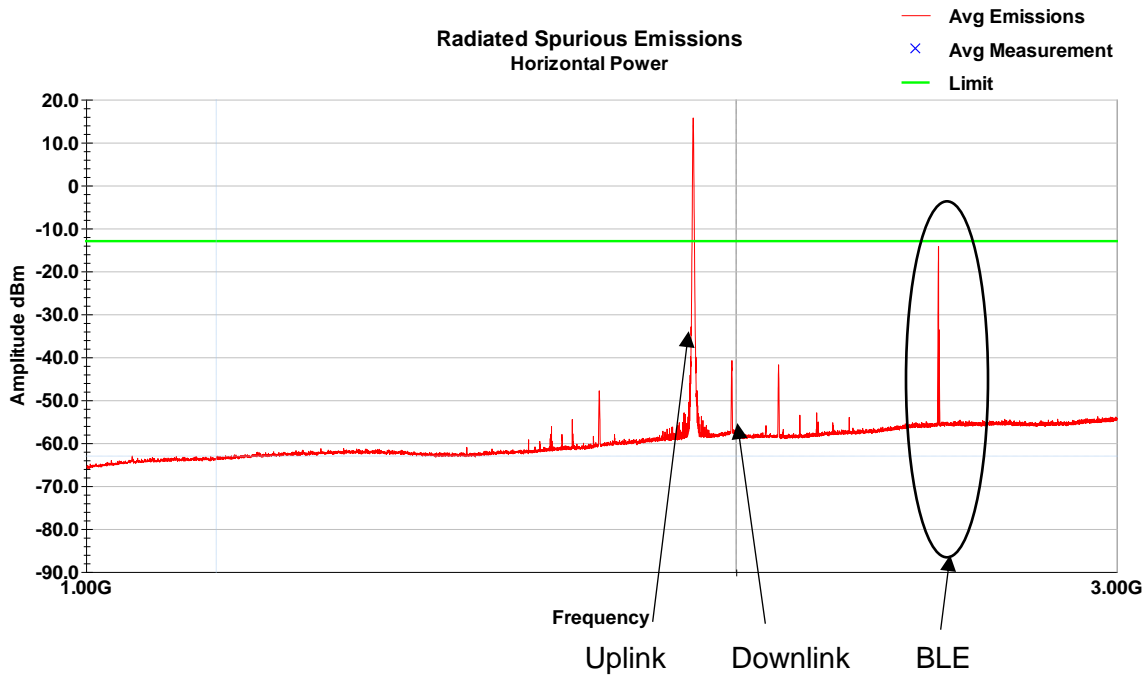

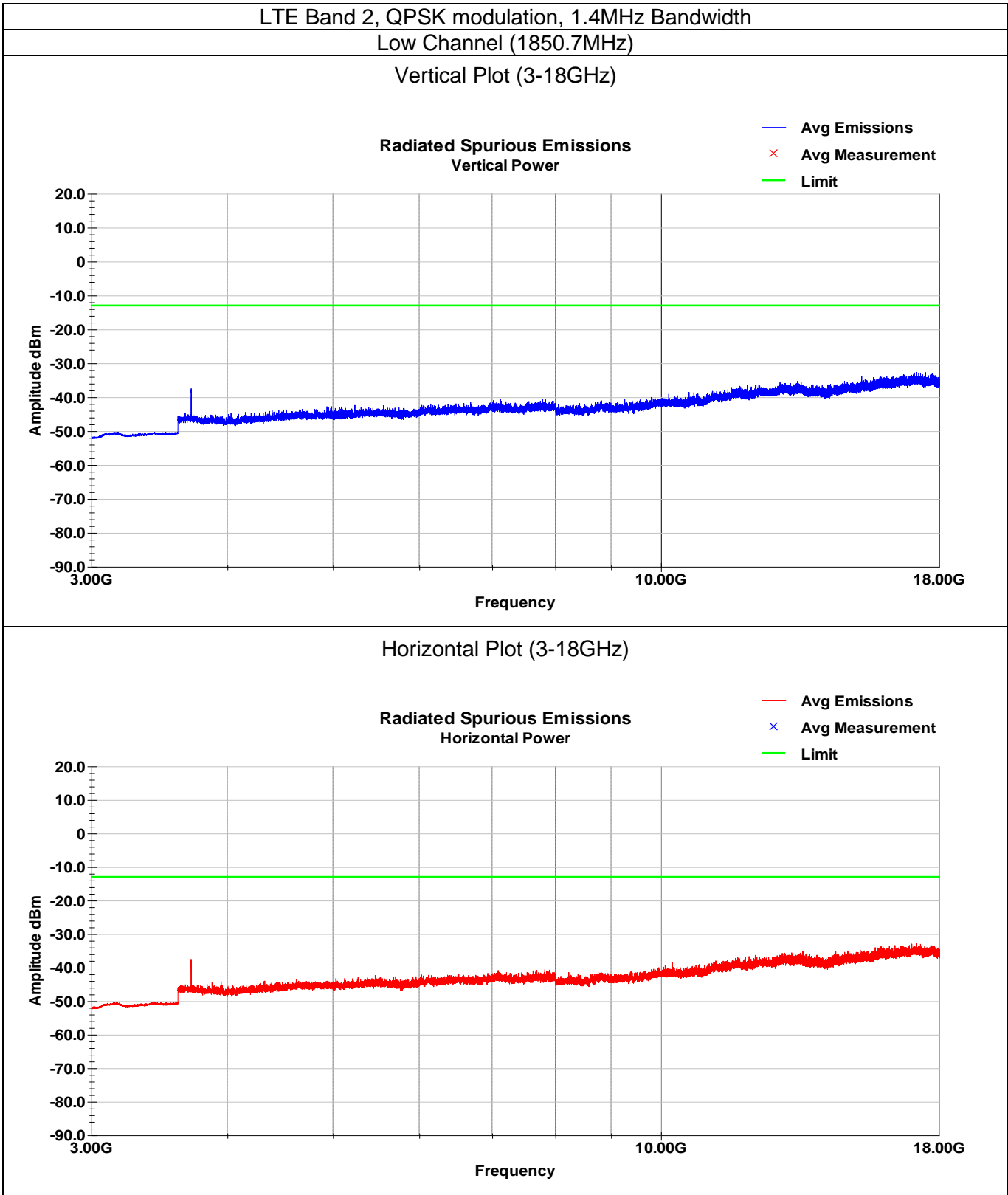

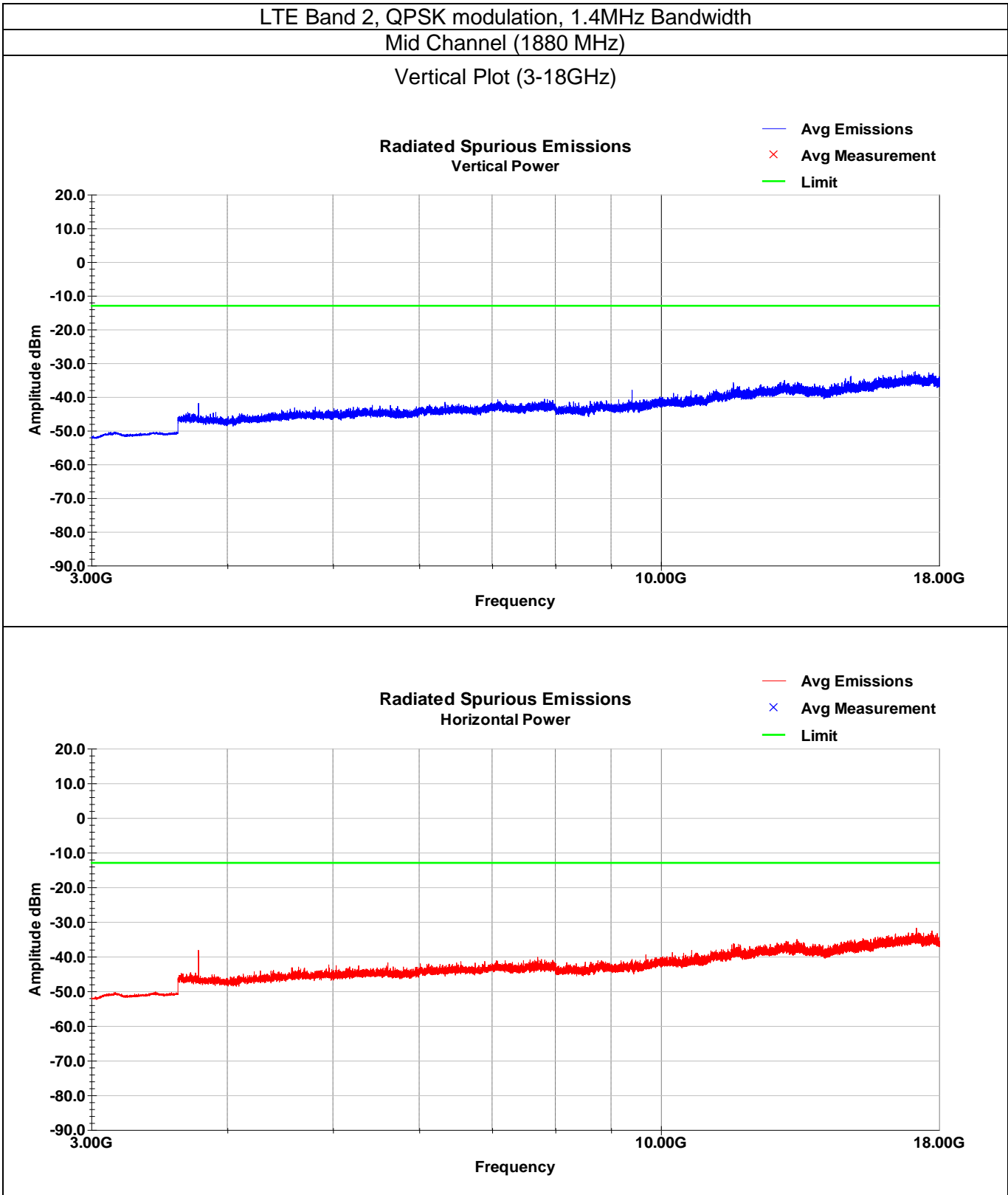

LTE Band 2, QPSK modulation, 1.4MHz Bandwidth
 High Channel (1909.3 MHz)

Vertical Plot (3-18GHz)

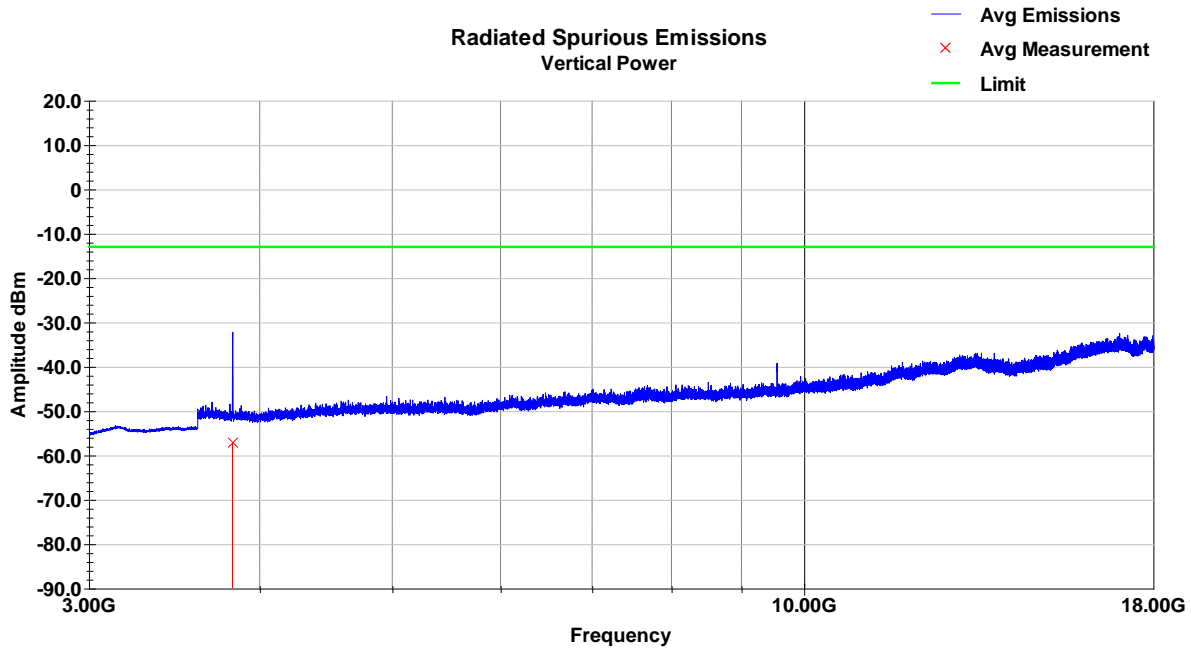

Vertical Data (3-18GHz)

Frequency MHz	Raw Avg dBm	Polarity V/H	Azimuth degrees	Height cm	AF dB/m	Loss dB	Amp dB	Avg Value dBm	Limit dBm	Margin dB
3820.92	-52.9	V	202.0	227.0	33.3	4.4	42.0	-57.2	-13.0	-44.2
QP Value = Level + AF + CL - Amp										
Margin = QP Value - Limit										

LTE Band 2, QPSK modulation, 1.4MHz Bandwidth

High Channel (1909.3 MHz)

Horizontal Plot (3-18GHz)

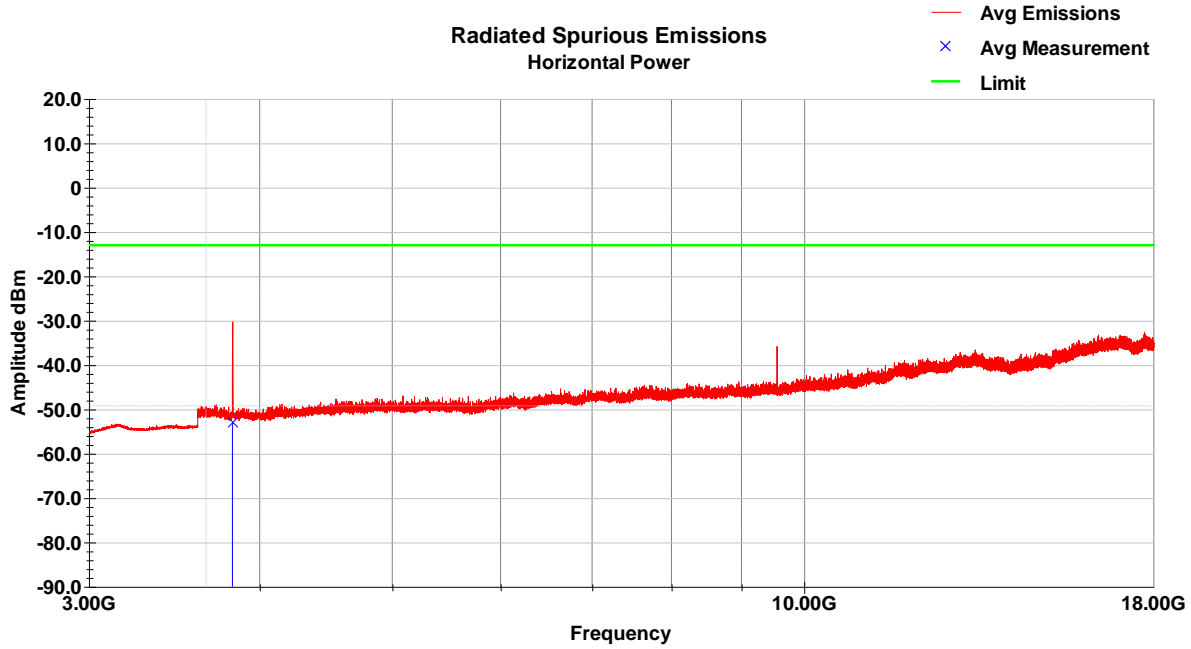

Horizontal Data (3-18GHz)

Frequency MHz	Raw Avg dBm	Polarity V/H	Azimuth degrees	Height cm	AF dB/m	Loss dB	Amp dB	Avg Value dBm	Limit dBm	Margin dB
3820.44	-48.8	H	178.0	206.0	33.3	4.4	42.0	-53.1	-13.0	-40.1
QP Value = Level + AF + CL - Amp										
Margin = QP Value - Limit										

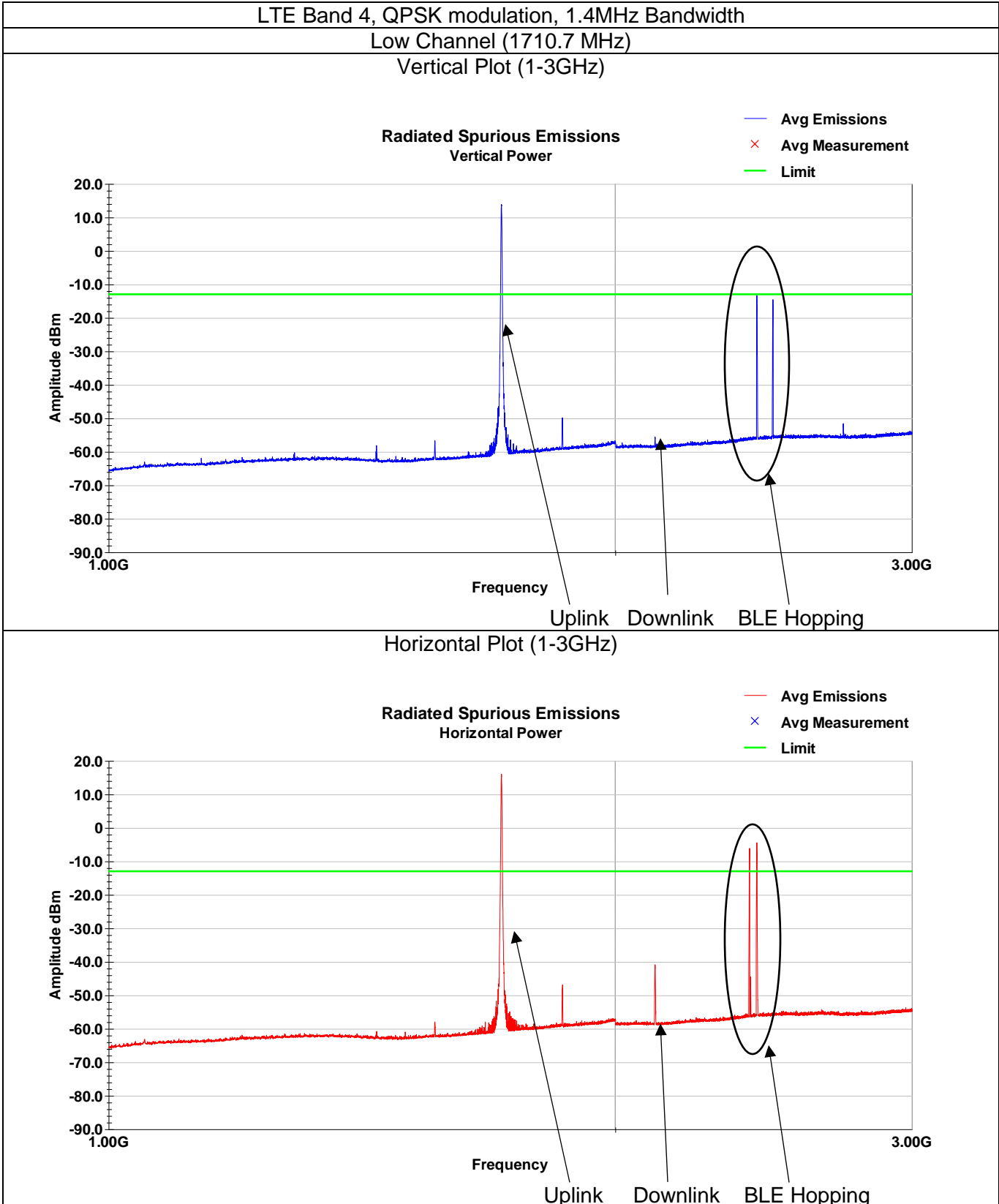

Note: Other than intentional, no emissions were within 20dB of limit.

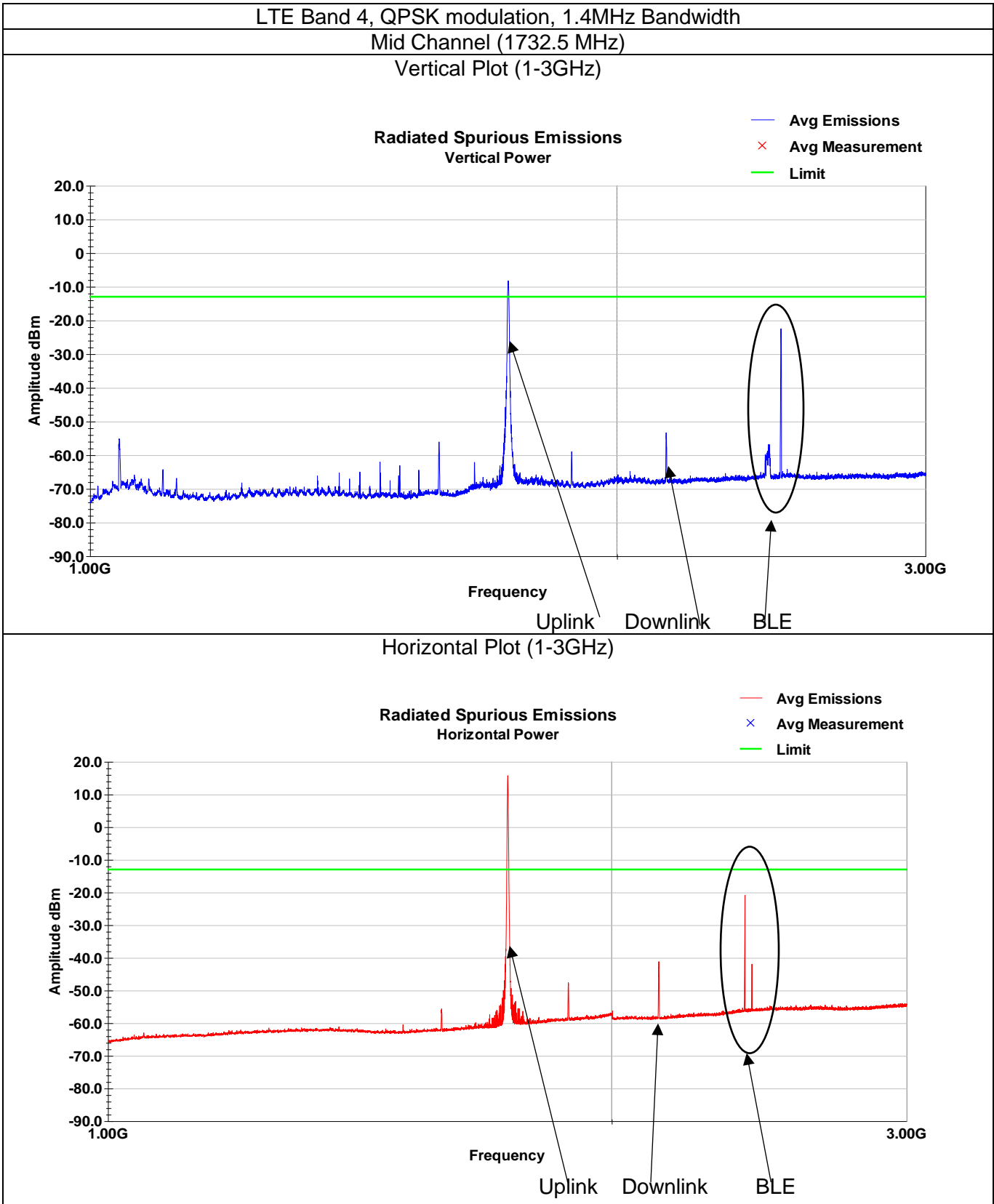

Note: Other than intentional, no emissions were within 20dB of limit.

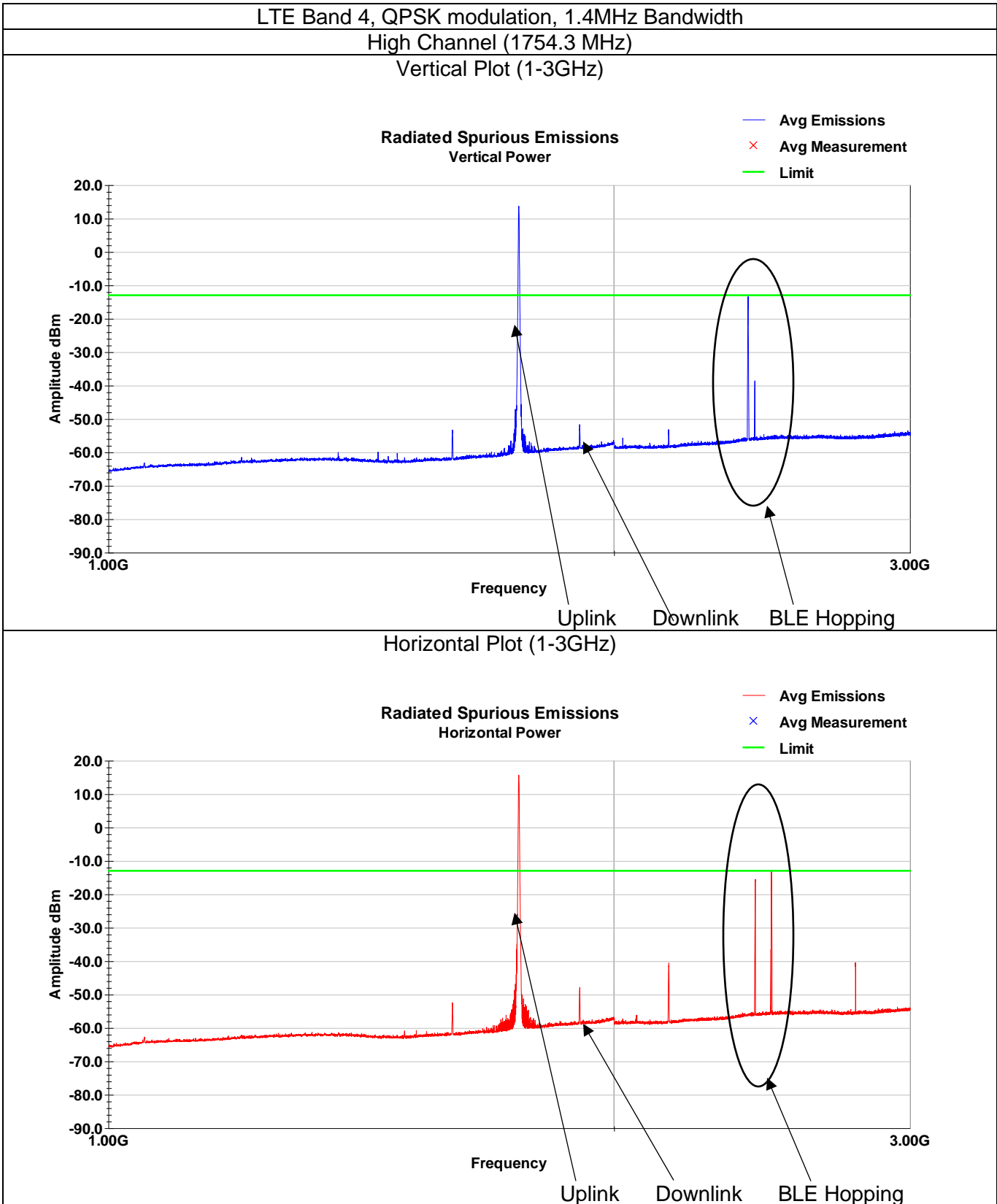

Note: Other than intentional, no other emissions within 20dB of limit.

LTE Band 4, QPSK modulation, 1.4MHz Bandwidth

Low Channel (1710.7 MHz)

Vertical Plot (3-18GHz)

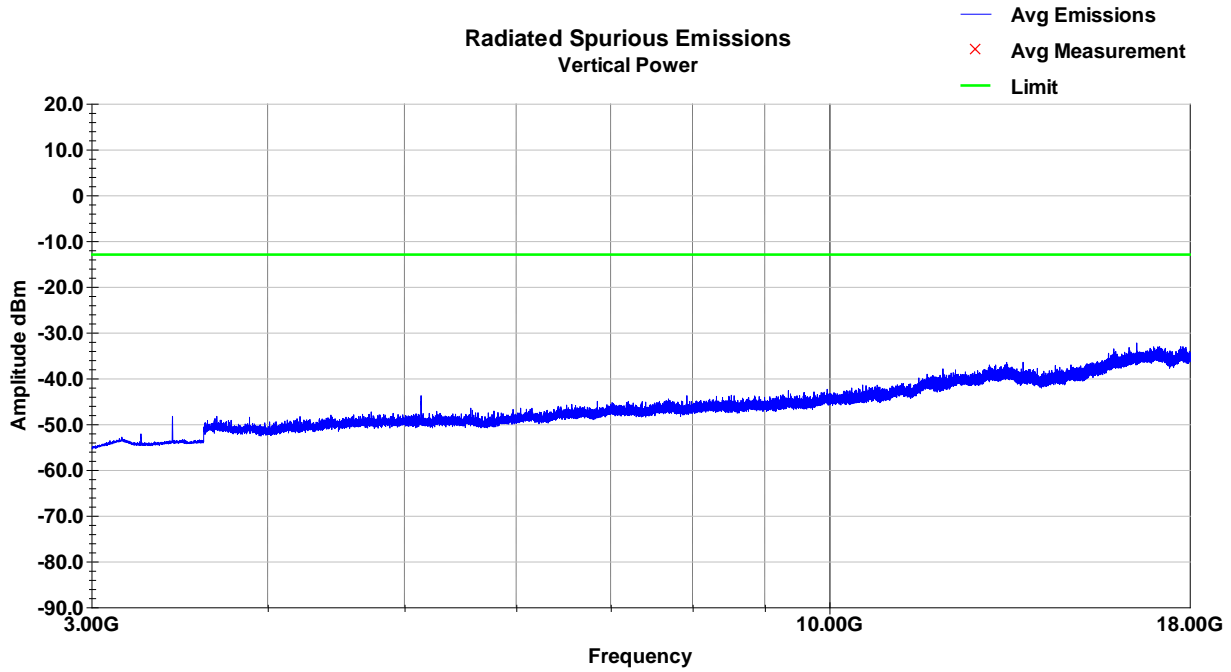

Horizontal Plot (3-18GHz)

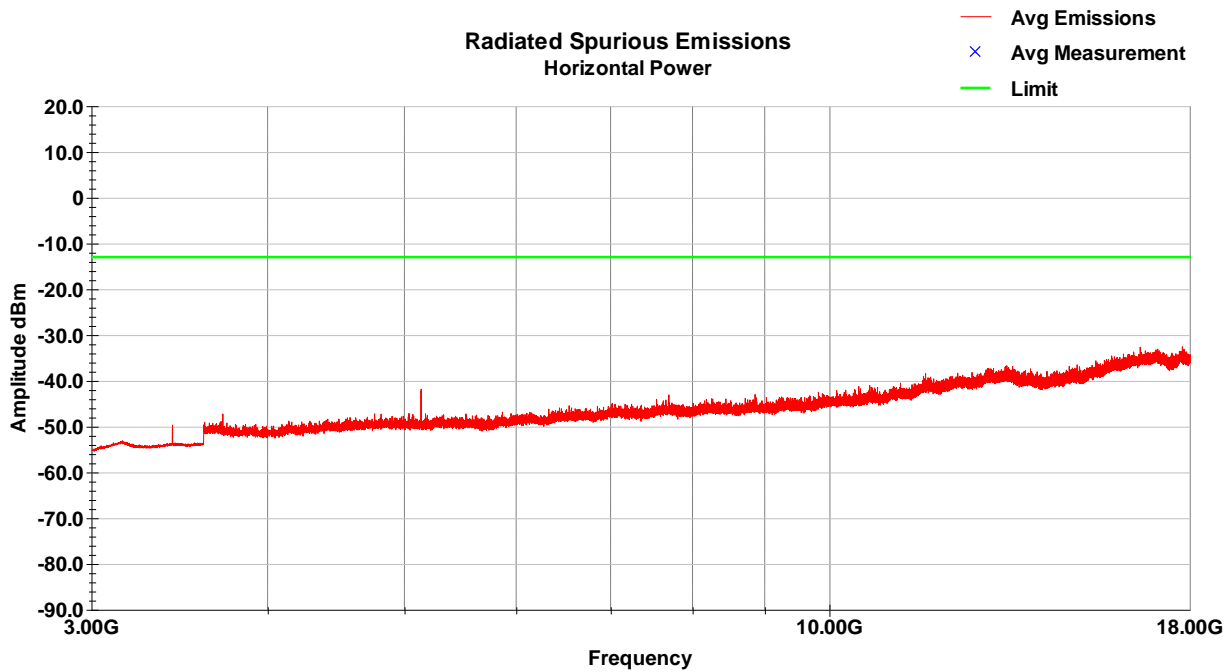

Note: No emissions within 20dB of limit.

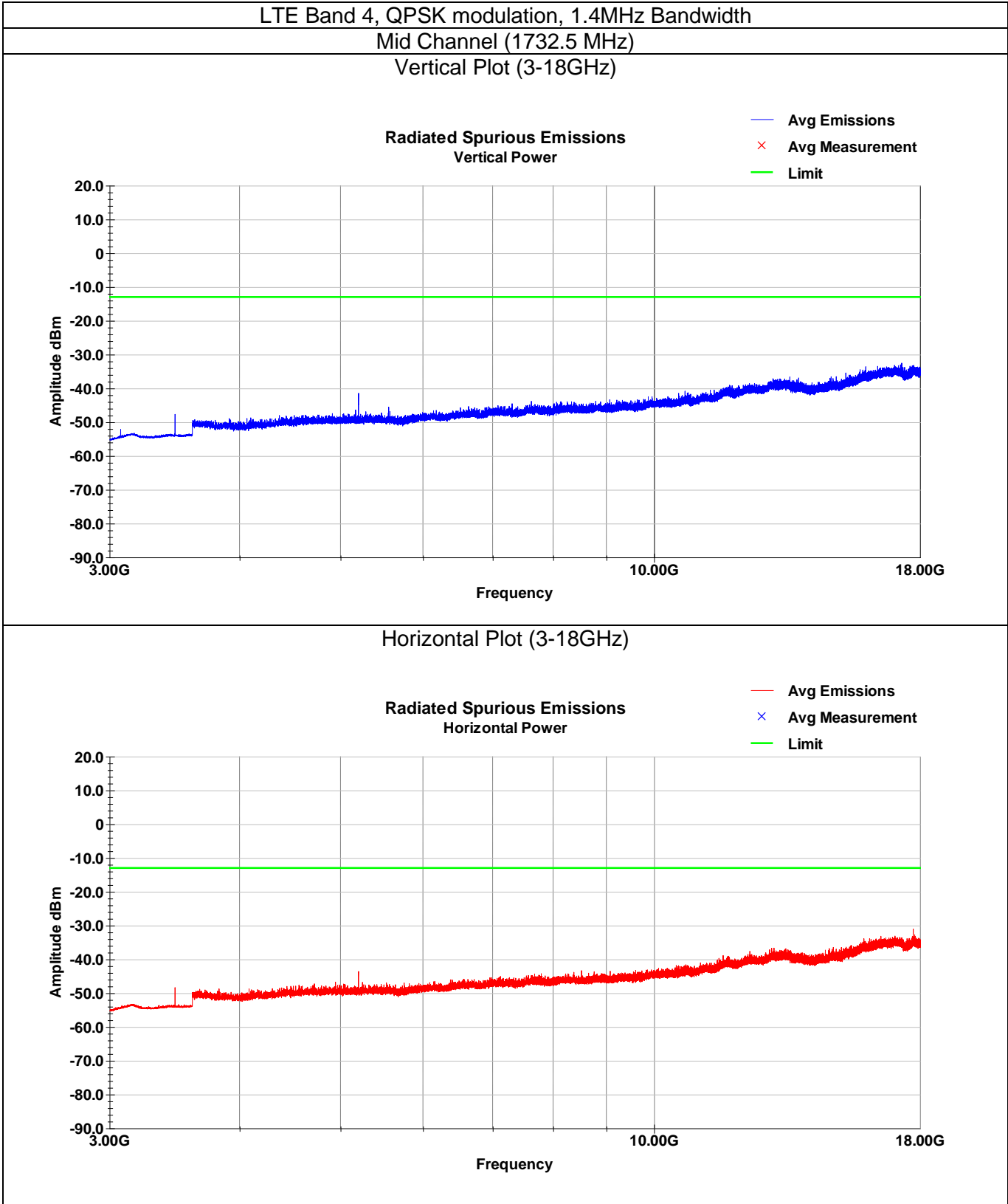

Note: No emissions within 20dB of limit.

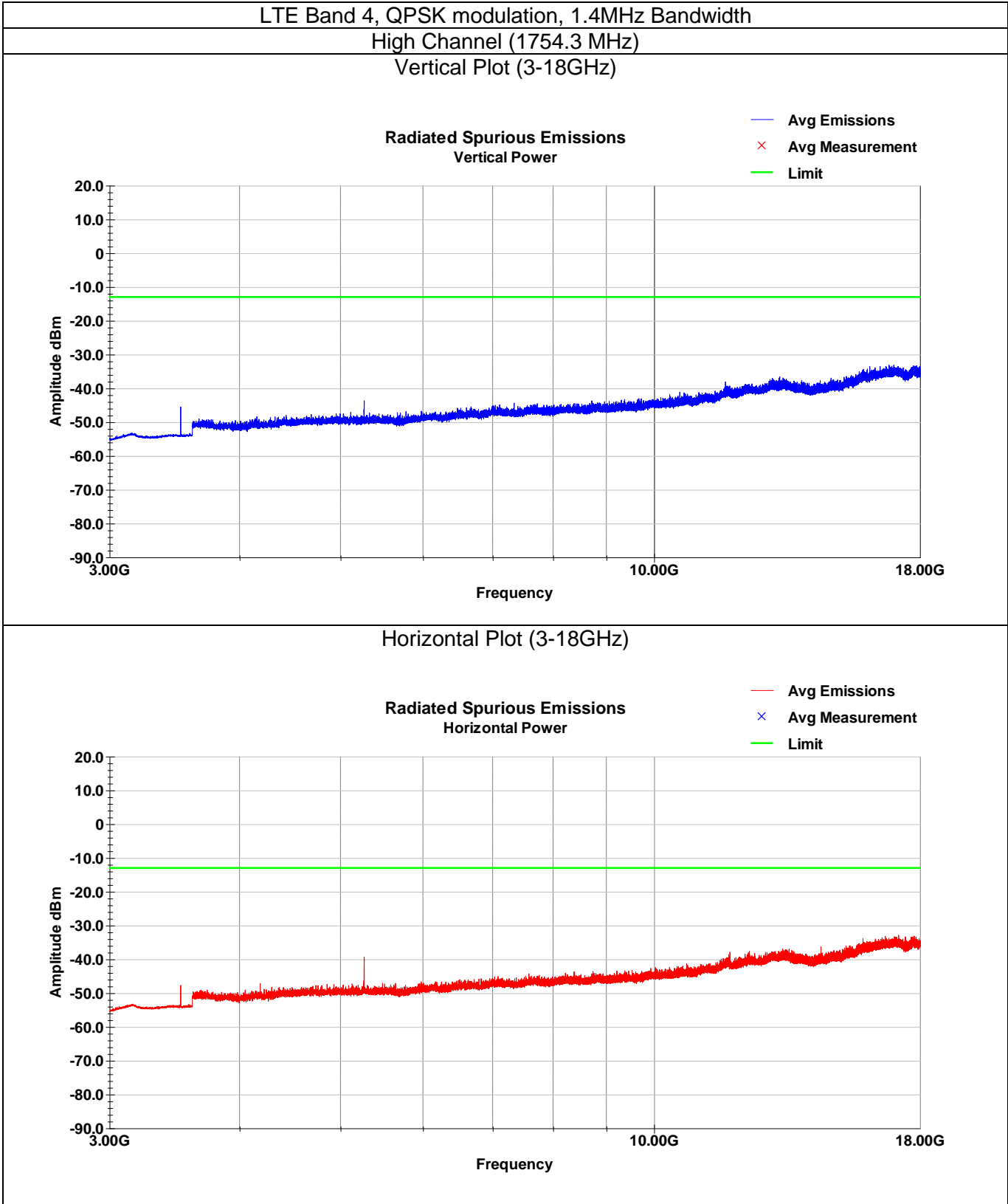

Note: No emissions within 20dB of limit.

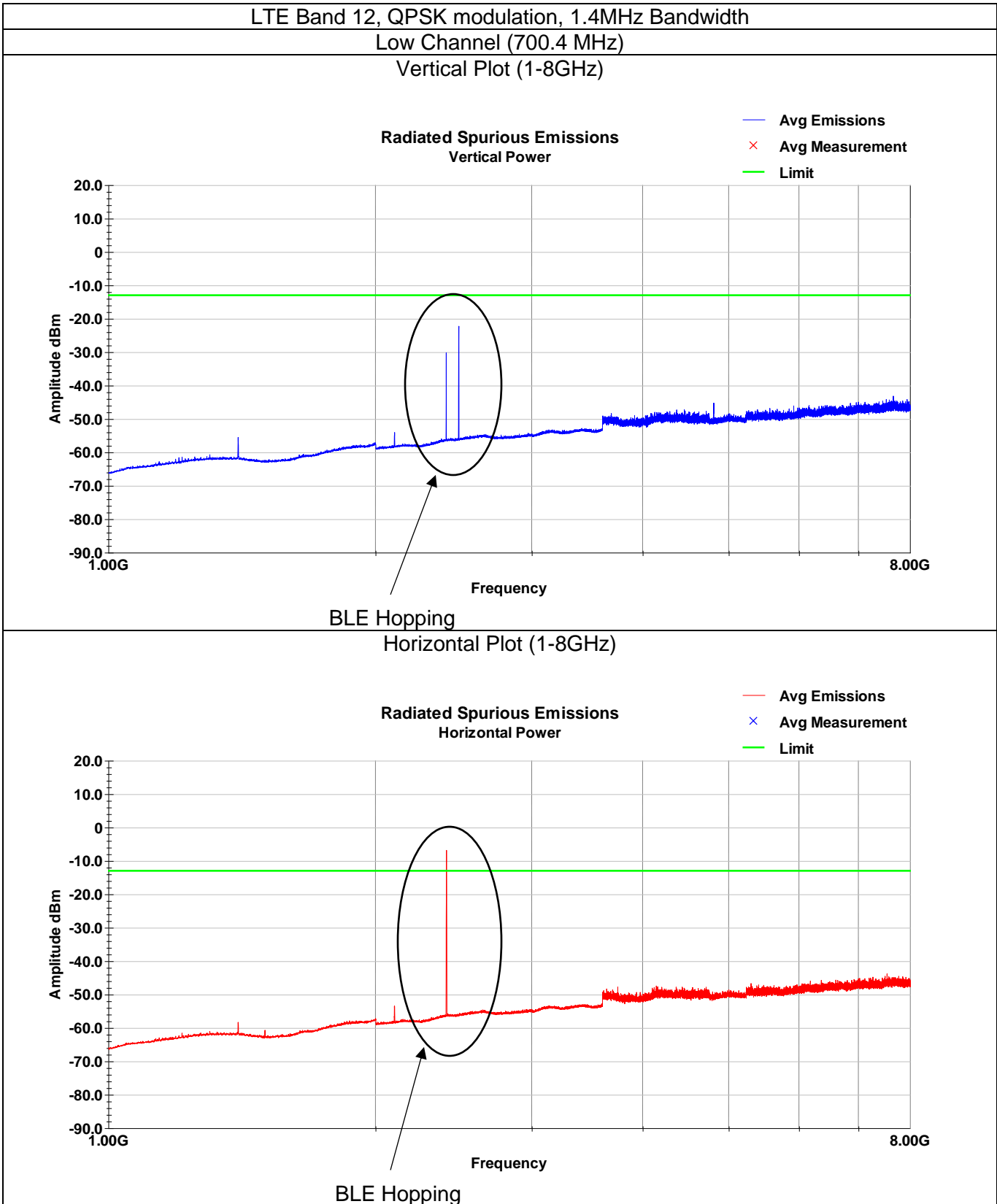

Note: Other than intentional, no emissions within 20dB of limit.

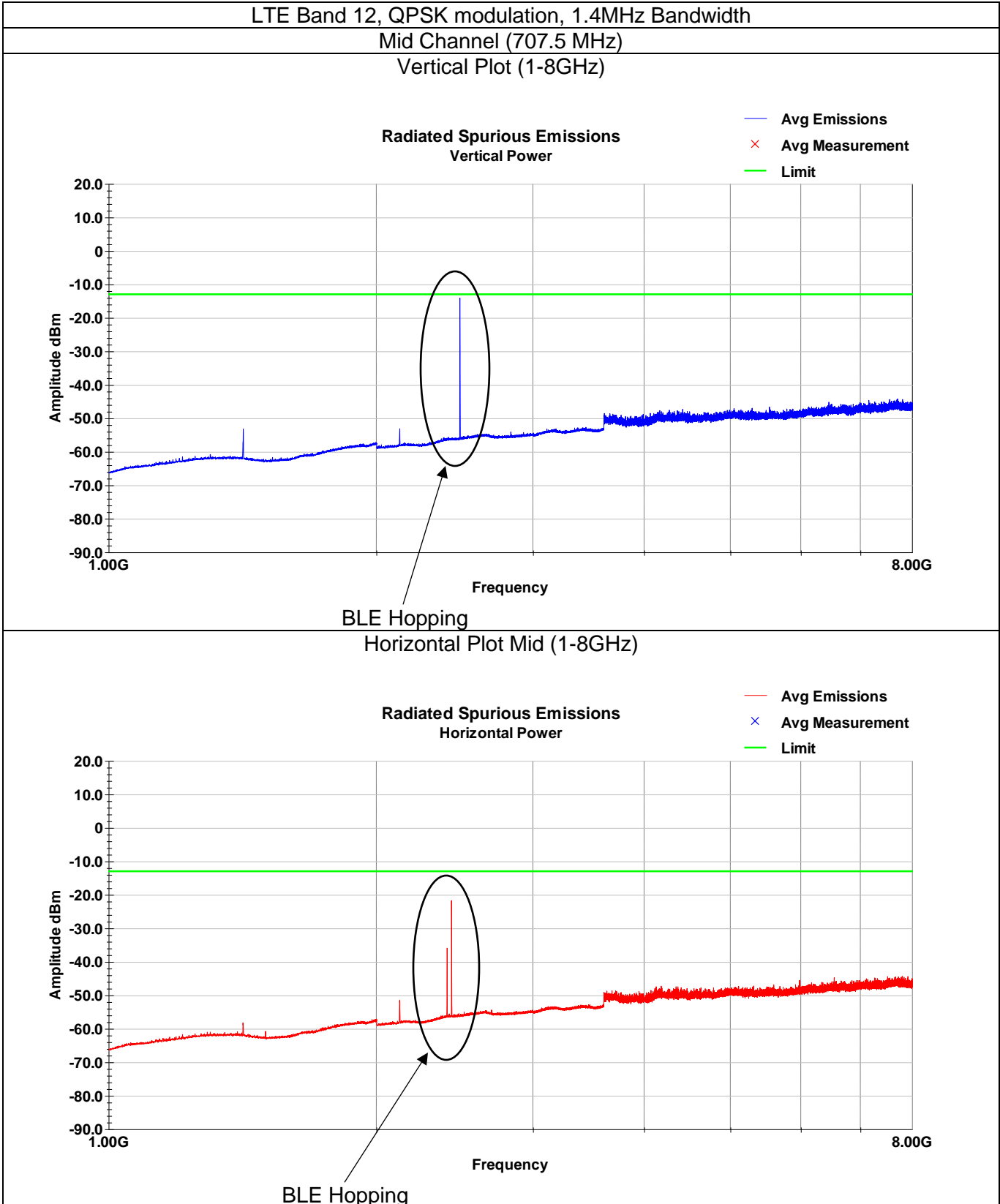

Note: Other than intentional, no emissions within 20dB of limit.

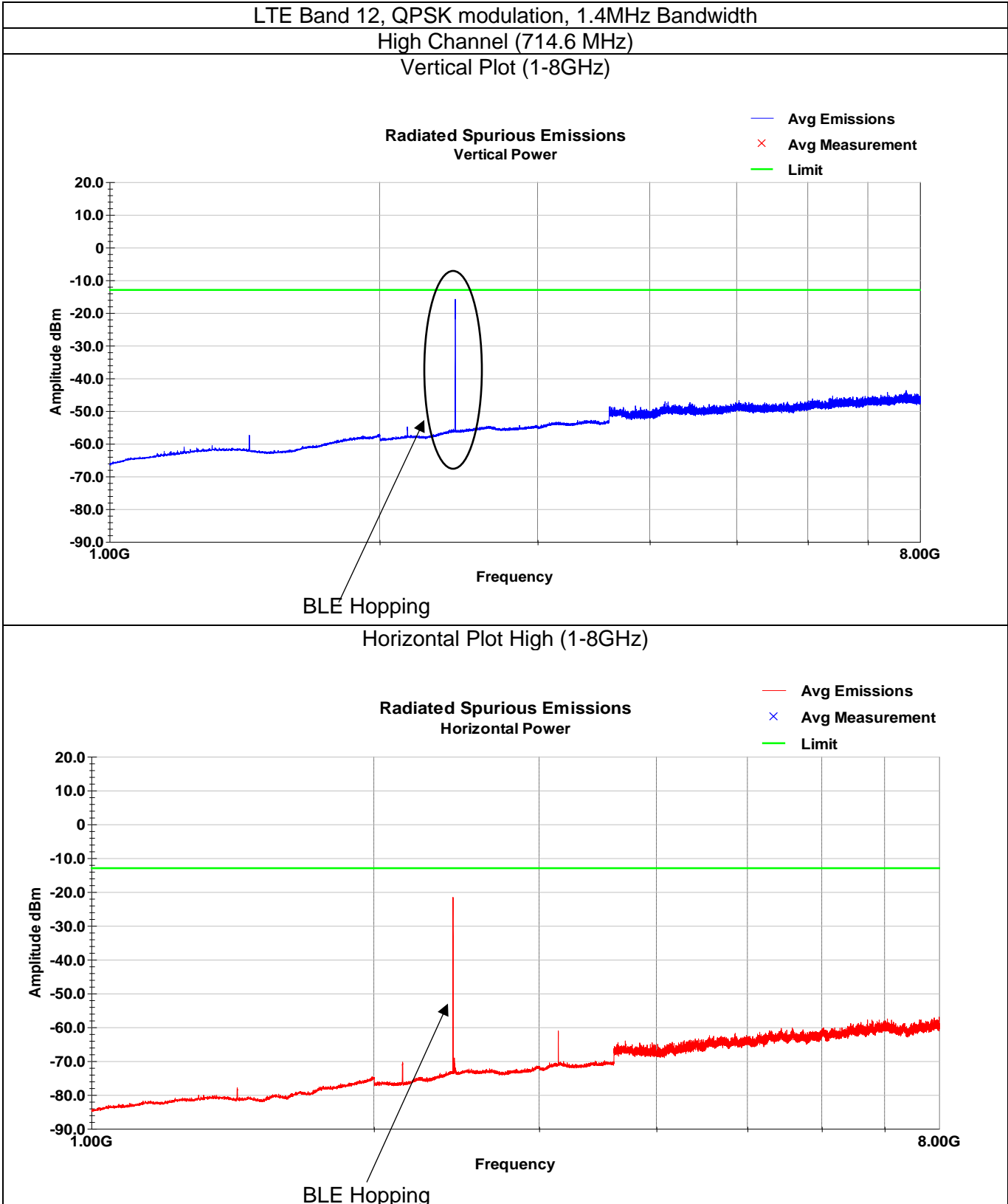

Note: Other than intentional, no emissions within 20dB of limit.

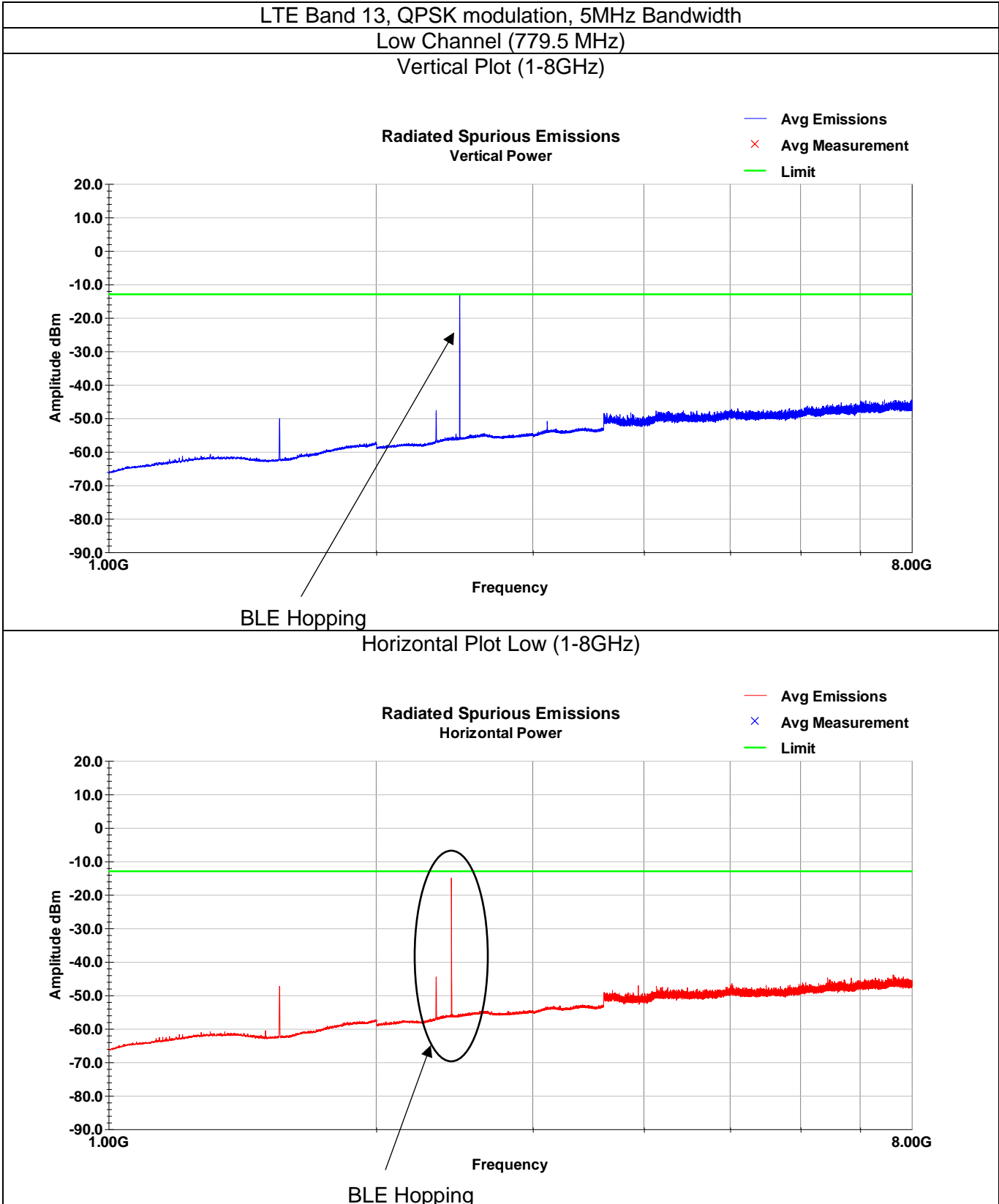

Note: Other than intentional, no emissions within 20dB of limit.

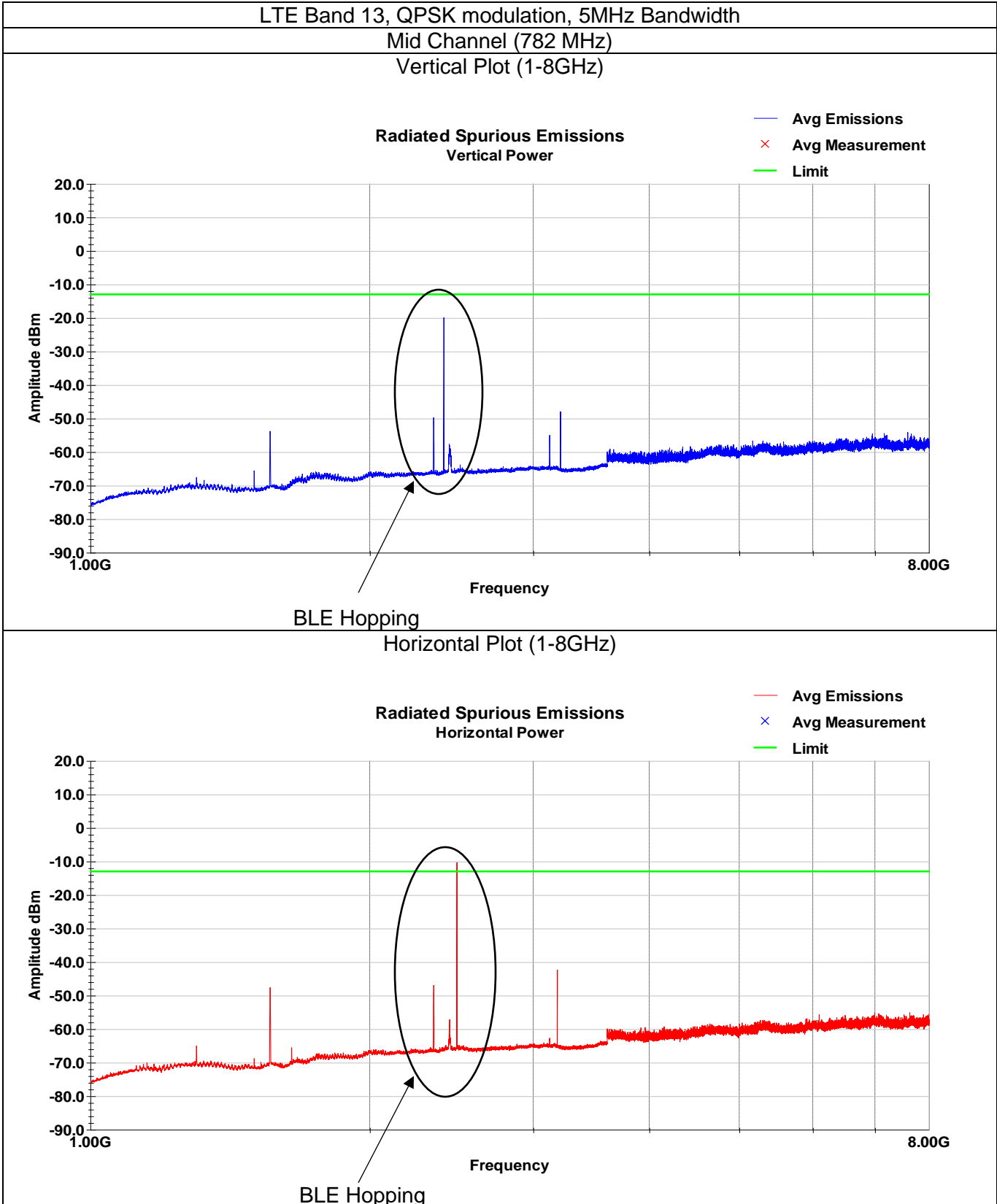

Note: Other than intentional, no emissions within 20dB of limit.

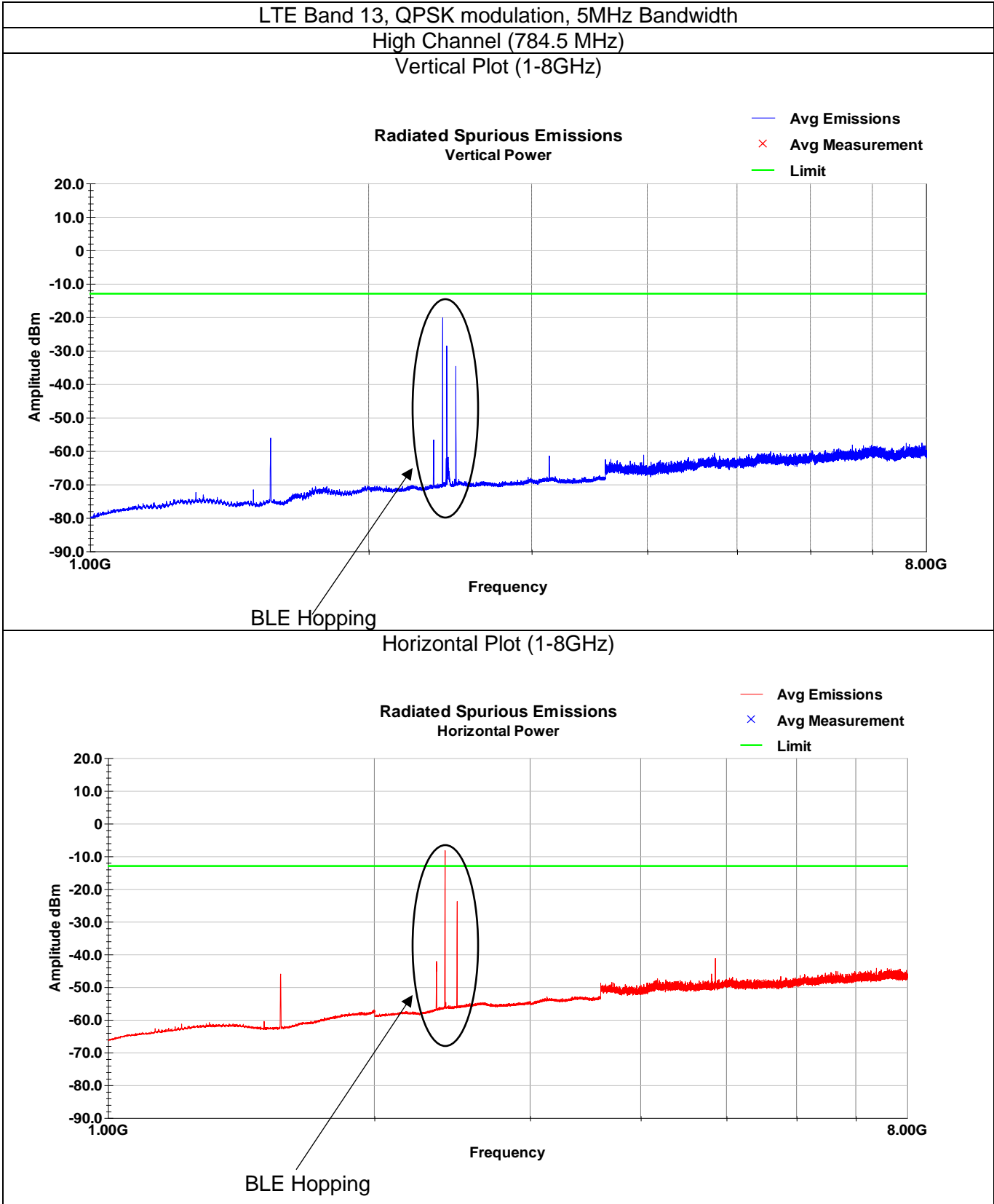

Note: Other than intentional, no emissions within 20dB of limit.

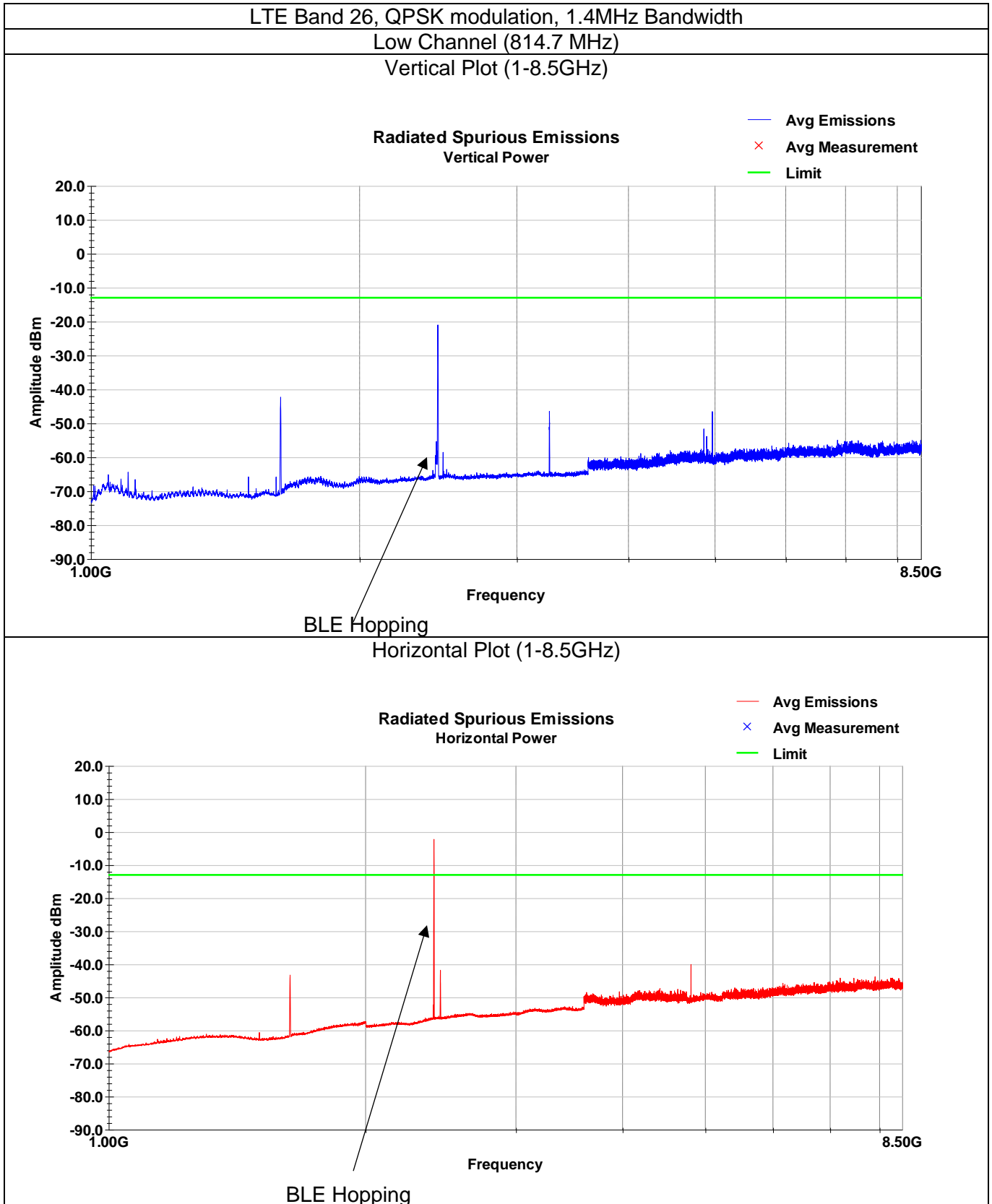

Note: Other than intentional, no emissions within 20dB of limit.

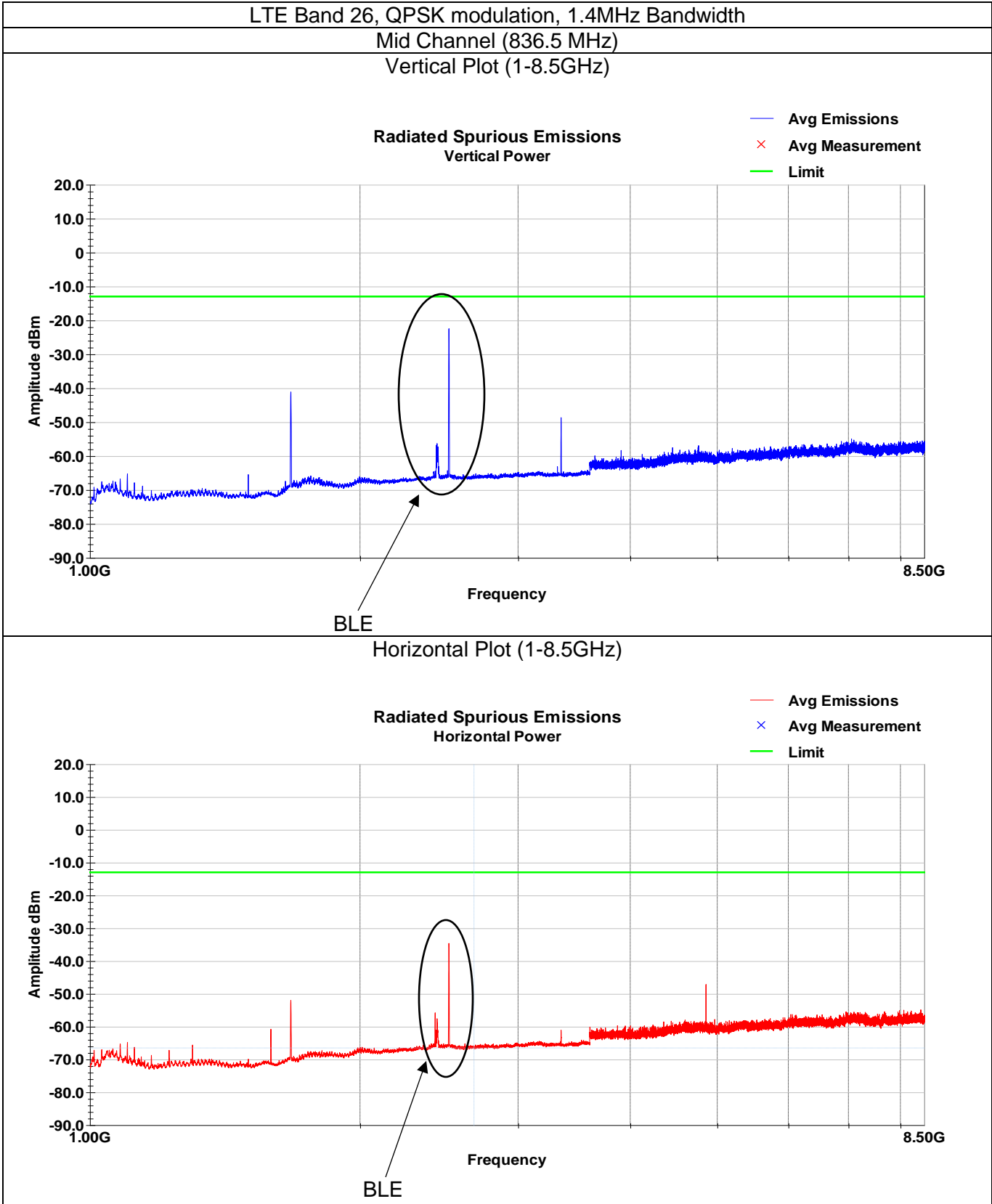

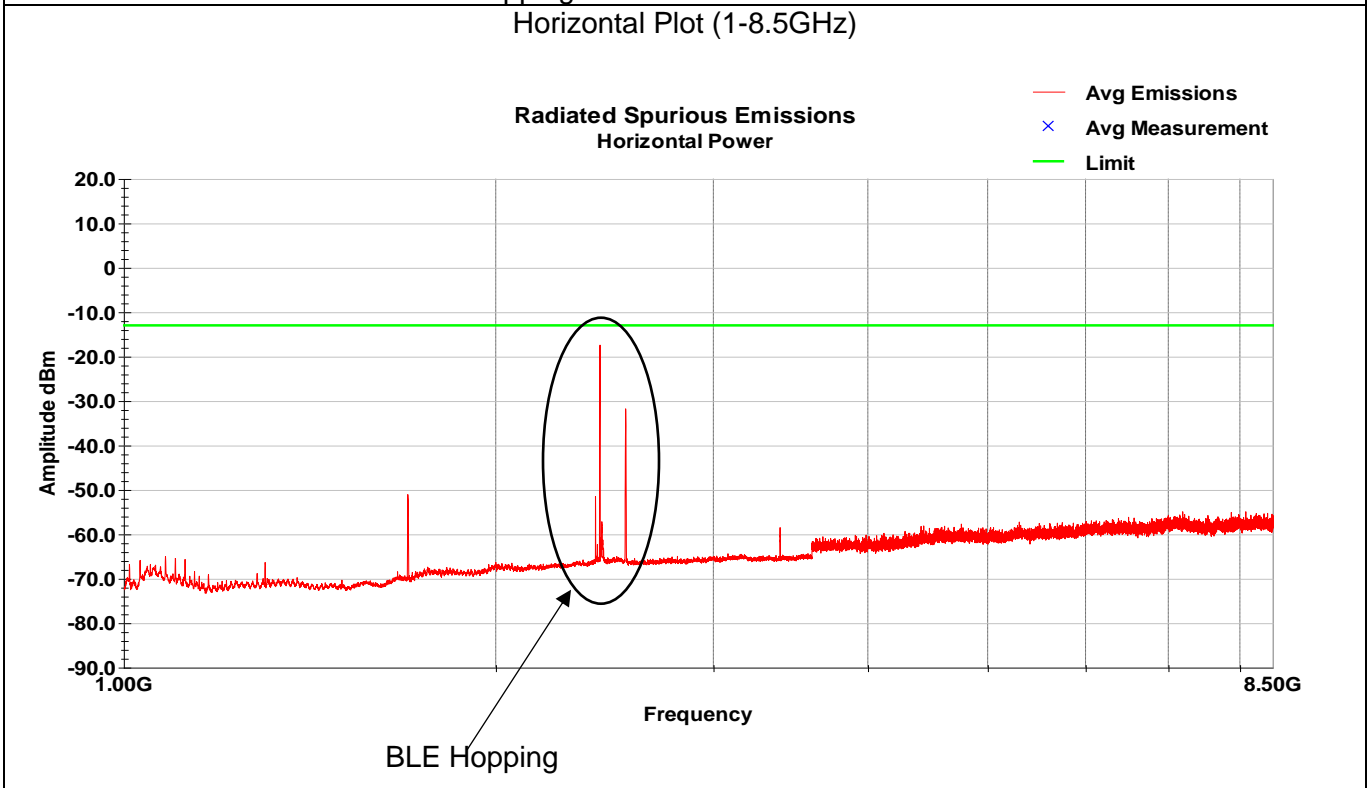
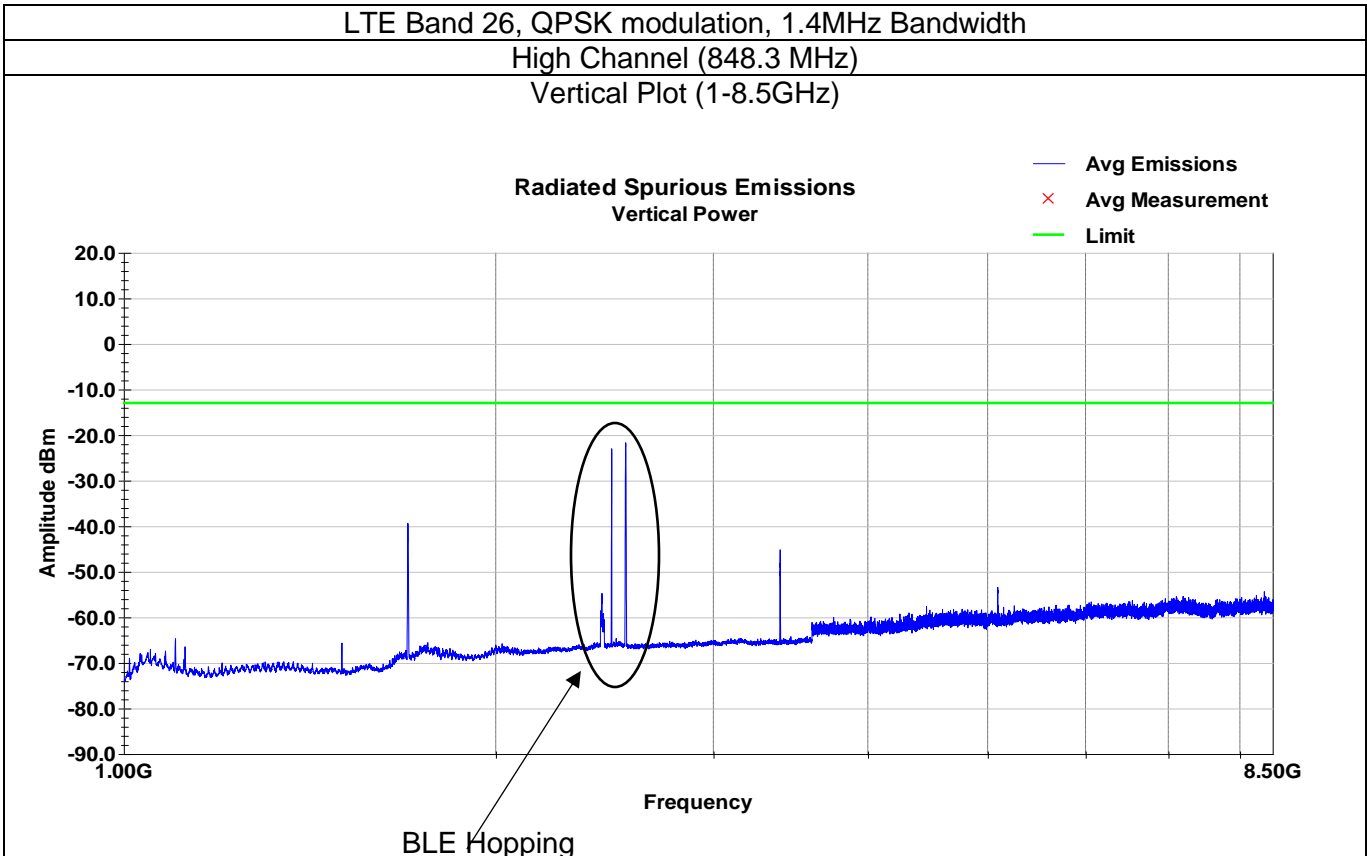

4 Revision History

Revision Level	Description of changes	Revision Date
0	Initial release	30 September 2021