

# 2.0X1.2X0.6 (mm) WiFi/Bluetooth Ceramic Chip Antenna (YF2012-1) Engineering Specification

## 1. Product Number

YF	2012	H2	P	2G45	00
1	2	3	4	5	6



(1)Product Type	Chip Antenna
(2)Size Code	2.0x1.2mm
(3)Type Code	H2
(4)Packing	Paper &Reel
(5)Frequency	2.45GHz
(6)Internal code	00



深圳市迎丰天线技术有限公司

SHEN ZHEN YINGFENG ANTENNA TECHNOLOGYCO.,LTD

Prepared by : **JIEXI**      Designed by : **Jason**      Checked by : **Jason**      Approved by : **MR.FANG**

TITLE : 2.0 x 1.2 x 0.6(mm) WiFi/Bluetooth Ceramic Chip Antenna (YF2012-1) Engineering Specification	DOCUMENT NO.	YF2012H2P2G4500	REV.
			D

## 2. Features

- \*Stable and reliable in performances
- \*Low temperature coefficient of frequency
- \*Low profile, compact size
- \*RoHS compliance
- \*SMT processes compatible

## 3. Applications

- \*Bluetooth earphone systems
- \*Hand-held devices when WiFi /Bluetooth functions are needed, e.g., Smart phone.
- \*IEEE802.11 b/g/n
- \*ZigBee
- \*Wireless PCMCIA cards or USB dongle

## 4. Description

Yingfeng chip antenna series are specially designed for WiFi/Bluetooth applications. Based on yingfeng proprietary design and processes, this chip antenna has excellent stability and sensitivity to consistently provide high signal reception efficiency.

## 5. Electrical Specifications (80 x 40 mm<sup>2</sup> ground plane)

5-1. Electrical Table

Characteristics		Specifications	Unit
Outline Dimensions		2.0x1.2x0.6	mm
Working Frequency		2400~2500	MHz
VSWR		2 Max.	
Impedance		50	Ω
Polarization		Linear Polarization	
Gain	Peak	2.5 (typical)	dBi
	Efficiency	75 (typical)	%



深圳市迎丰天线技术有限公司

SHEN ZHEN YINGFENG ANTENNA TECHNOLOGY CO., LTD

Prepared by : JIEXI

Designed by : Jason

Checked by : Jason

Approved by : MR.FANG

TITLE : 2.0 x 1.2 x 0.6(mm) WiFi/Bluetooth Ceramic Chip  
Antenna (YF2012-1) Engineering Specification

DOCUMENT  
NO.

YF2012H2P2G4500

REV.  
D

## 5-2. Return Loss & VSWR

### Return Loss (S<sub>11</sub>)

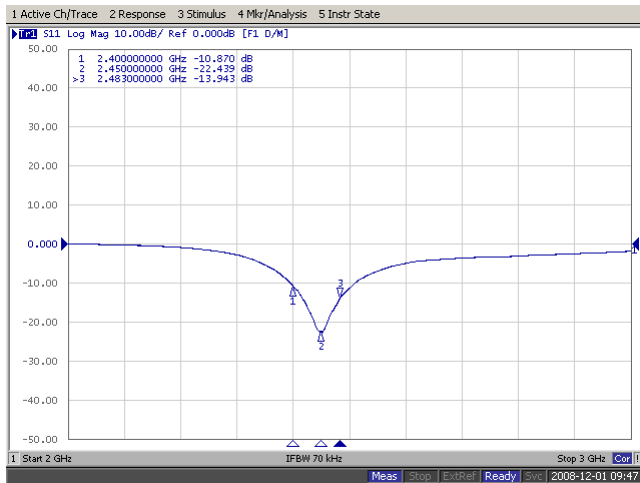

### VSWR(S<sub>11</sub>)

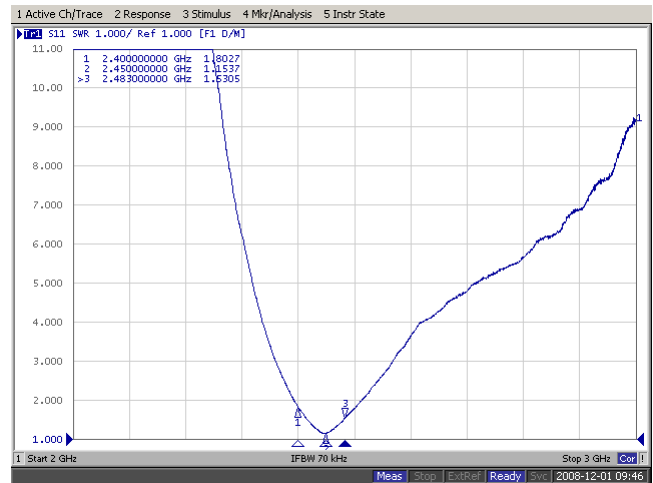

## 6. Antenna Dimensions & Test Board (unit: mm)

### a. Antenna Dimensions

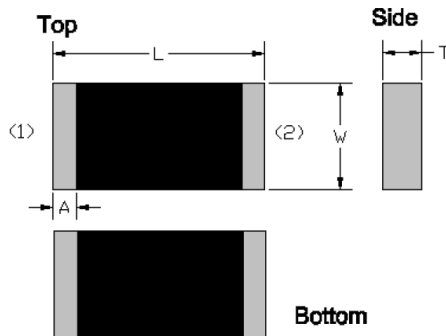

Dimension (mm)	
L	2.05±0.15
W	1.20±0.15
T	0.50±0.10
A	0.20±0.10

No.	Terminal Name
1	Feeding/GNG
2	GND/Feeding

*P.S : Top & down and left & right side are symmetrical, No direction*



深圳市迎丰天线技术有限公司

SHEN ZHEN YINGFENG ANTENNA TECHNOLOGY CO., LTD

Prepared by : JIEXI

Designed by : Jason

Checked by : Jason

Approved by : MR.FANG

TITLE : 2.0 x 1.2 x 0.6(mm) WiFi/Bluetooth Ceramic Chip  
Antenna (YF2012-1) Engineering Specification

DOCUMENT  
NO.

YF2012H2P2G4500

REV.  
D

b. Test Board with Antenna

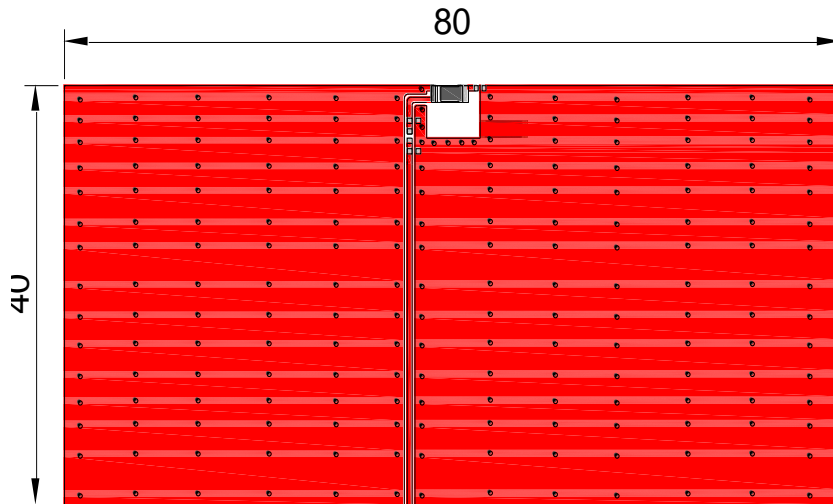

Unit: mm

7. Radiation Pattern (80 x 40 mm<sup>2</sup> ground plane)

7-1. 3D Gain Pattern @ 2442 MHz

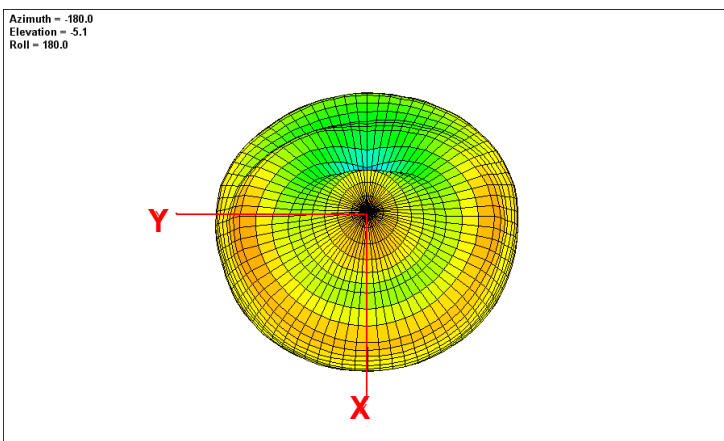
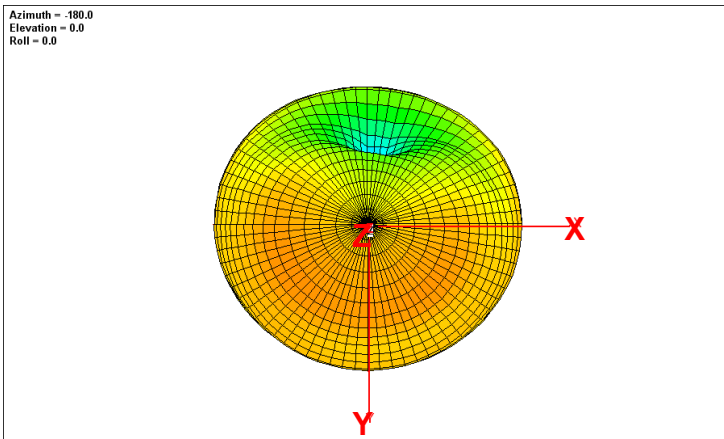

深圳市迎丰天线技术有限公司

SHEN ZHEN YINGFENG ANTENNA TECHNOLOGYCO.,LTD

Prepared by : JIEXI

Designed by : Jason

Checked by : Jason

Approved by : MR.FANG

TITLE : 2.0 x 1.2 x 0.6(mm) WiFi/Bluetooth Ceramic Chip  
Antenna (YF2012-1) Engineering Specification

DOCUMENT  
NO.

YF2012H2P2G4500

REV.  
D

Azimuth = 0.0  
Elevation = -90.0  
Roll = 180.0

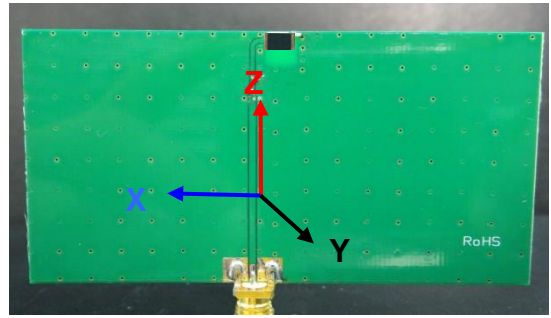
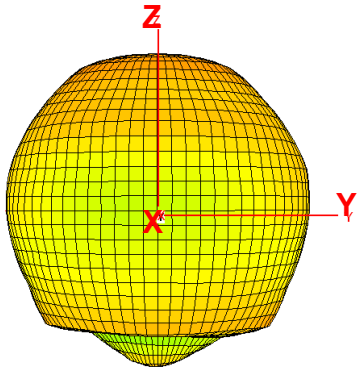

### 7-2. 3D Efficiency Table

Frequency( MHz)	2400	2410	2420	2430	2442	2450	2460	2470	2480	2490	2500
Efficiency (dB)	-1.4	-1.0	-0.9	-0.7	-0.7	-0.8	-0.9	-1.1	-1.2	-1.3	-1.4
Efficiency (%)	72.8	73.7	74.3	74.4	75.5	75.0	74.0	73.6	73.1	72.6	71.5
Gain (dBi)	2.1	2.2	2.3	2.4	2.5	2.5	2.4	1.8	1.7	1.6	1.4

### 7-3. 3D Efficiency vs. Frequency

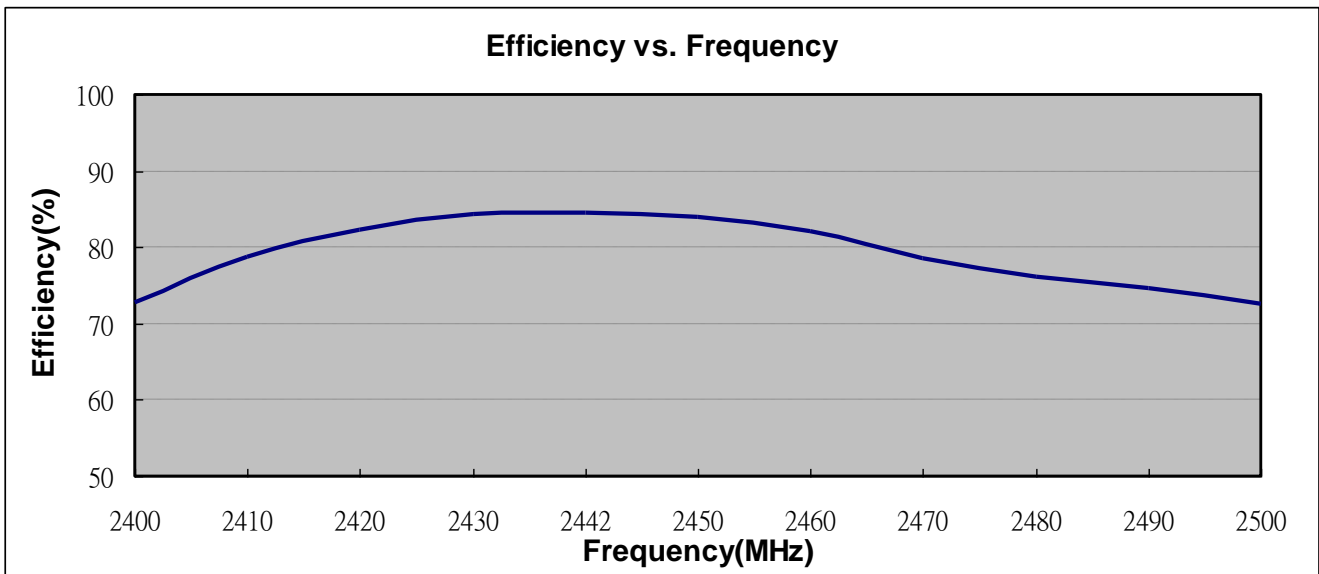

深圳市迎丰天线技术有限公司

SHEN ZHEN YINGFENG ANTENNA TECHNOLOGYCO.,LTD

Prepared by : JIEXI

Designed by : Jason

Checked by : Jason

Approved by : MR.FANG

TITLE : 2.0 x 1.2 x 0.6(mm) WiFi/Bluetooth Ceramic Chip  
Antenna (YF2012-1) Engineering Specification

DOCUMENT  
NO.

YF2012H2P2G4500

REV.  
D

## 8. Layout Guide

### a. Solder Land Pattern:

Land pattern for soldering (gray marking areas) is as shown below. Depending on Customer's requirement, matching circuit as shown below is also recommended.

### 2). PCB Top View :

Type1 :

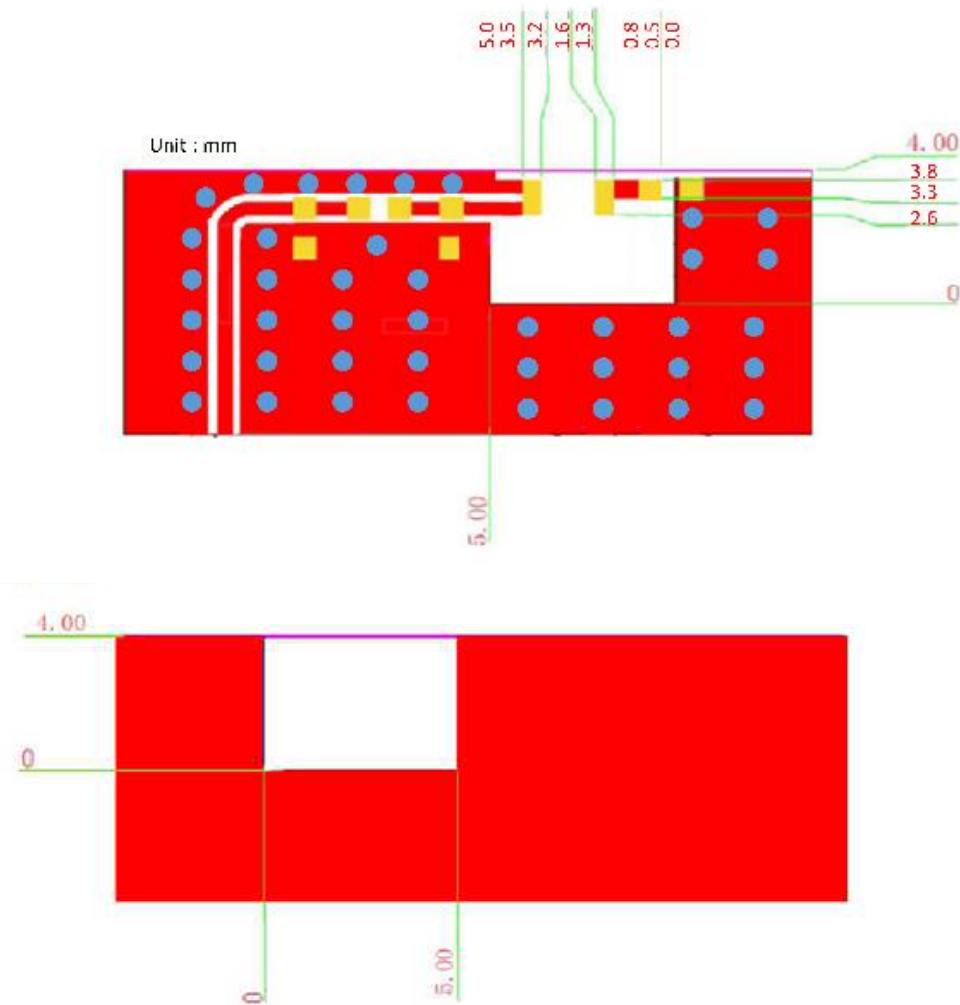

Bottom View



深圳市迎丰天线技术有限公司

SHEN ZHEN YINGFENG ANTENNA TECHNOLOGY CO., LTD

Prepared by : JIEXI

Designed by : Jason

Checked by : Jason

Approved by : MR.FANG

TITLE : 2.0 x 1.2 x 0.6(mm) WiFi/Bluetooth Ceramic Chip  
Antenna (YF2012-1) Engineering Specification

DOCUMENT  
NO.

YF2012H2P2G4500

REV.  
D

## 9. Frequency tuning

a. Chip antenna tuning scenario :

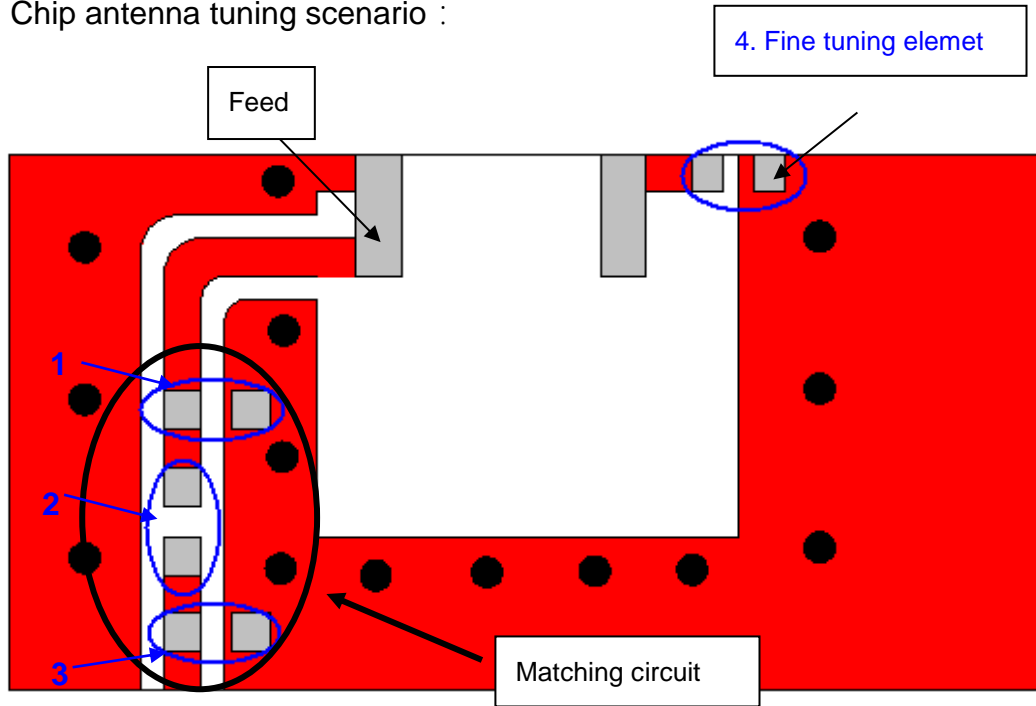

b. Matching circuit : (Center frequency is about 2442 MHz @ 80 x 40 mm<sup>2</sup> ground plane)

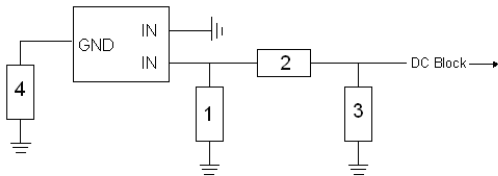

System Matching Circuit Component			
Location	Description	Vendor	Tolerance
1	1.2 pF*	Murata (0402)	±0.1 pF
2	10PF*	Murata(0402)	±0.5 PF
3	N/A*	-	-
Fine tuning element 4	1.5 pF*	Murata (0402)	±0.1 pF

\*Typical reference values which may need to be changed when circuit



深圳市迎丰天线技术有限公司

SHEN ZHEN YINGFENG ANTENNA TECHNOLOGYCO.,LTD

Prepared by : JIEXI

Designed by : Jason

Checked by : Jason

Approved by : MR.FANG

TITLE : 2.0 x 1.2 x 0.6(mm) WiFi/Bluetooth Ceramic Chip Antenna (YF2012-1) Engineering Specification

DOCUMENT NO.

YF2012H2P2G4500

REV. D

boards or part vendors are different.

c. Fine tuning element vs. Center frequency

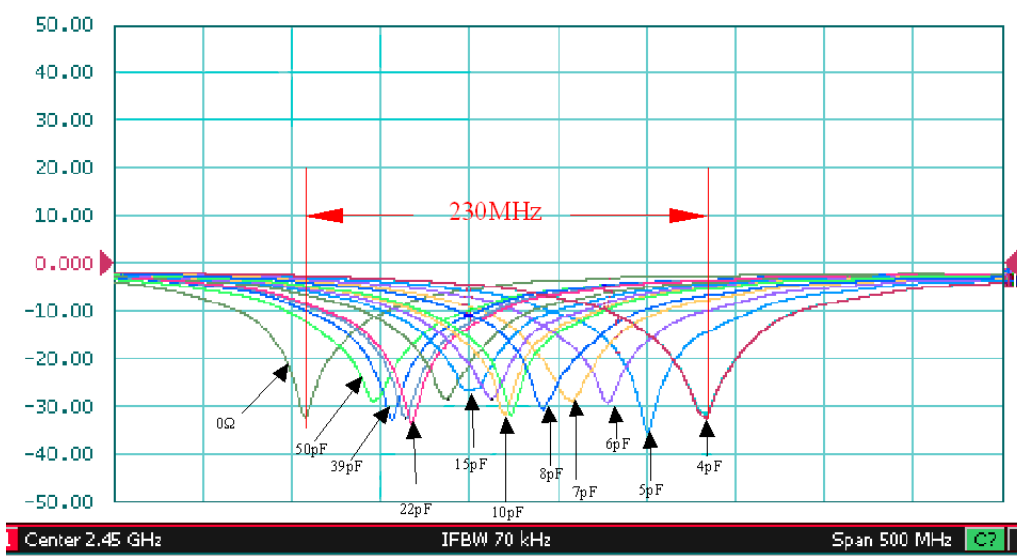

## 10. Soldering Conditions

a. Typical Soldering Profile for Lead-free Process

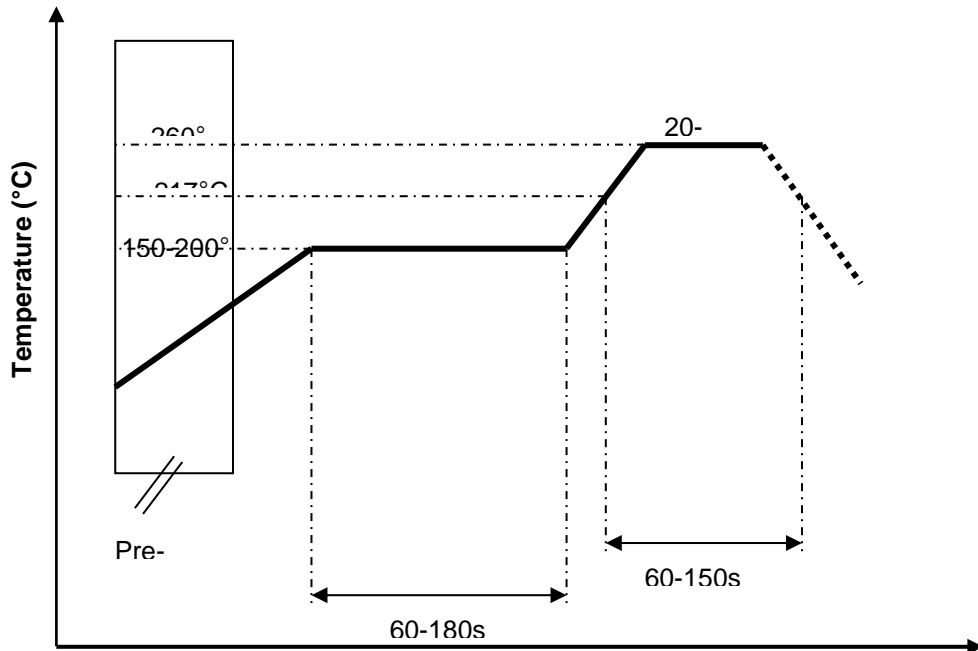

Time  
深圳市迎丰天线技术有限公司

SHEN ZHEN YINGFENG ANTENNA TECHNOLOGY CO., LTD

Prepared by : JIEXI

Designed by : Jason

Checked by : Jason

Approved by : MR.FANG

TITLE : 2.0 x 1.2 x 0.6(mm) WiFi/Bluetooth Ceramic Chip  
Antenna (YF2012-1) Engineering Specification

DOCUMENT  
NO.

YF2012H2P2G4500

REV.  
D



# 11. Packing

- (1) Quantity/Reel: 5000 pcs/Reel
- (2) Plastic tape:

**Reel and Taping Specification**

**Reel Specification**

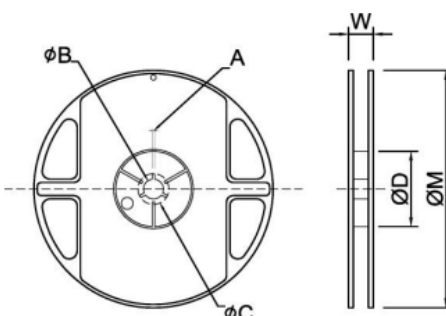

TYPE	SIZE		A	φ B	φ C	φ D	W	φ M
2012	7"	5K/Reel	2.0±0.5	13.5±1.0	21±1.0	60±1.0	11.5±2.0	178±2.0

**Tapping Specification**

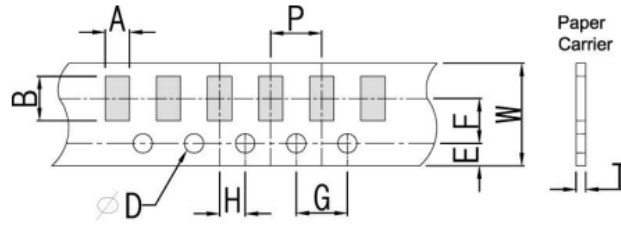

Packaging	Type	A	B	W	E	F	G	H	T	φD	P
Paper Type	2012	1.90±0.20	3.50±0.20	8.0±0.20	1.75±0.10	3.5±0.05	4.0±0.10	2.0±0.05	0.75±0.10	1.50 +0.10 -0	4.0±0.1



深圳市迎丰天线技术有限公司

SHEN ZHEN YINGFENG ANTENNA TECHNOLOGYCO.,LTD

Prepared by : JIEXI

Designed by : Jason

Checked by : Jason

Approved by : MR.FANG

**TITLE : 2.0 x 1.2 x 0.6(mm) WiFi/Bluetooth Ceramic Chip Antenna (YF2012-1) Engineering Specification**

**DOCUMENT NO.**

**YF2012H2P2G4500**

**REV. D**

## Reliability Table

Test Item	Procedure	Requirements Ceramic Type	Remark (Reference)
Electrical Characterization		Fulfill the electrical specification	User Spec.
Thermal Shock	1. Preconditioning: 50 ± 10°C / 1 hr, then keep for 24 ± 1 hrs at room temp. 2. Initial measure: Spec: refer Initial spec. 3. Rapid change of temperature test -30°C to +85°C; 100 cycles; 15 minutes at Lower category temperature; 15 minutes at Upper category temperature.	No Visible Damage. Fulfill the electrical specification.	MIL-STD-202 107
Temperature Cycling	1. Initial measure: Spec: refer Initial spec. 2. 100 Cycles (-30°C to +85°C), Soak Mode=1 (2 Cycle/hours). 3. Measurement at 24 ± 2Hours after test condition.	No Visible Damage. Fulfill the electrical specification.	JESD22 JA104
High Temperature Exposure	1. Initial measure: Spec: refer Initial spec. 2. Unpowered; 500hours @ T=+85°C. 3. Measurement at 24 ± 2 hours after test.	No Visible Damage. Fulfill the electrical specification.	MIL-STD-202 108
Low Temperature Storage	1. Initial measure: Spec: refer Initial spec. 2. Unpowered; 500hours @ T= -30°C. 3. Measurement at 24 ± 2 hours after test.	No Visible Damage. Fulfill the electrical specification.	MIL-STD-202 108
Solderability (SMD Bottom Side)	Dipping method: a. Temperature: 235 ± 5°C b. Dipping time: 3 ± 0.5s	The solder should cover over 95% of the critical area of bottom side.	IEC 60384-21/22 4.10
Soldering Heat Resistance (RSH)	Preheating temperature: 150 ± 10°C. Preheating time: 1~2 min. Solder temperature: 260 ± 5°C. Dipping time: 5 ± 0.5s	No Visible Damage.	IEC 60384-21/22 4.10
Vibration	5g's for 20 min., 12 cycles each of 3 orientations Note: Use 8"x5" PCB .031" thick 7 secure points on, one long side and 2 secure points at corners of opposite sides. Parts mounted within 2" from any secure point. Test from 10-2000 Hz.	No Visible Damage.	MIL-STD-202 Method 204
Mechanical Shock	Three shocks in each direction shall be applied along the three mutually perpendicular axes of the test specimen (18 shocks) Peak value: 1,500g's Duration: 0.5ms Velocity change: 15.4 ft/s Waveform: Half-sine	No Visible Damage.	MIL-STD-202 Method 213
Humidity Bias	1. Humidity: 85% R.H., Temperature: 85 ± 2 °C. 2. Time: 500 ± 24 hours. 3. Measurement at 24 ± 2hrs after test condition.	No Visible Damage. Fulfill the electrical specification.	MIL-STD-202 Method 106



深圳市迎丰天线技术有限公司

SHEN ZHEN YINGFENG ANTENNA TECHNOLOGYCO.,LTD

Prepared by : JIEXI

Designed by : Jason

Checked by : Jason

Approved by : MR.FANG

TITLE : 2.0 x 1.2 x 0.6(mm) WiFi/Bluetooth Ceramic Chip  
Antenna (YF2012-1) Engineering Specification

DOCUMENT  
NO.

YF2012H2P2G4500

REV.  
D

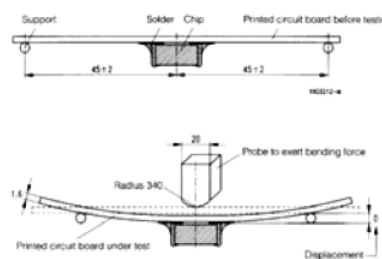
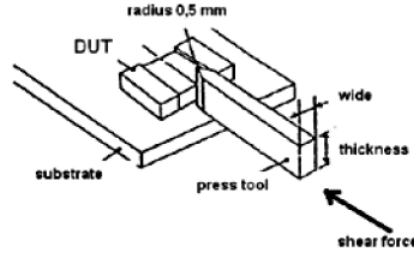
<b>Board Flex (SMD)</b>	<p>1. Mounting method: IR-Reflow. PCB Size (L:100 × W:40 × T:1.6mm)</p> <p>2. Apply the load in direction of the arrow until bending reaches 2 mm.</p> 	No Visible Damage.	AEC-Q200 005
<b>Adhesion</b>	<p>Force of 1.8Kg for 60 seconds.</p> 	No Visible Damage Magnification of 20X or greater may be employed for inspection of the mechanical integrity of the device body terminals and body/terminal junction.	AEC-Q200 006
<b>Physical Dimension</b>	<p>Any applicable method using x10 magnification, micrometers, calipers, gauges, contour projectors, or other measuring equipment, capable of determining the actual specimen dimensions.</p>	In accordance with specification.	JESD22 JB100



深圳市迎丰天线技术有限公司

SHEN ZHEN YINGFENG ANTENNA TECHNOLOGYCO.,LTD

Prepared by : JIEXI

Designed by : Jason

Checked by : Jason

Approved by : MR.FANG

**TITLE : 2.0 x 1.2 x 0.6(mm) WiFi/Bluetooth Ceramic Chip Antenna (YF2012-1) Engineering Specification**

**DOCUMENT NO.**

**YF2012H2P2G4500**

**REV. D**