

# FCC Radio Test Report

## FCC ID: 2AXJ4WA1201V3

This report concerns: **Original Grant**

**Project No.** : 2201C045  
**Equipment** : AC1200 Wireless Gigabit Access Point  
**Brand Name** : tp-link  
**Test Model** : TL-WA1201  
**Series Model** : N/A  
**Applicant** : TP-Link Corporation Limited  
**Address** : Room 901, 9/F. , New East Ocean Centre, 9 Science Museum Road,  
Tsim Sha Tsui, Kowloon, Hong Kong  
**Manufacturer** : TP-Link Corporation Limited  
**Address** : Room 901, 9/F. , New East Ocean Centre, 9 Science Museum Road,  
Tsim Sha Tsui, Kowloon, Hong Kong  
**Date of Receipt** : Jan. 10, 2022  
**Date of Test** : Jan. 11, 2022 ~ Apr. 06, 2022  
**Issued Date** : Apr. 13, 2022  
**Report Version** : R00  
**Test Sample** : Engineering Sample No.: DG20220111132 for conducted,  
DG20220111131 & DG2022032558 for radiated.  
**Standard(s)** : FCC CFR Title 47, Part 15, Subpart E  
FCC KDB 789033 D02 General UNII Test Procedures New Rules v02r01  
FCC KDB 662911 D01 Multiple Transmitter Output v02r01  
ANSI C63.10-2013

The above equipment has been tested and found compliance with the requirement of the relative standards by BTL Inc.



Prepared by : Sheldon Ou



Approved by : Chay Cai



TESTING CERT #5123.02

Add: No. 3 Jinshagang 1st Rd. Shixia, Dalang Town Dongguan City, Guangdong 523792

People's Republic of China

Tel: +86-769-8318-3000

Web: [www.newbtl.com](http://www.newbtl.com)

**Declaration**

**BTL** represents to the client that testing is done in accordance with standard procedures as applicable and that test instruments used has been calibrated with standards traceable to international standard(s) and/or national standard(s).

**BTL's** reports apply only to the specific samples tested under conditions. It is manufacture's responsibility to ensure that additional production units of this model are manufactured with the identical electrical and mechanical components. **BTL** shall have no liability for any declarations, inferences or generalizations drawn by the client or others from **BTL** issued reports.

The report must not be used by the client to claim product certification, approval, or endorsement by NVLAP, NIST, A2LA, or any agency of the U.S. Government.

This report is the confidential property of the client. As a mutual protection to the clients, the public and ourselves, the test report shall not be reproduced, except in full, without our written approval.

**BTL's** laboratory quality assurance procedures are in compliance with the **ISO/IEC 17025** requirements, and accredited by the conformity assessment authorities listed in this test report.

**BTL** is not responsible for the sampling stage, so the results only apply to the sample as received.

The information, data and test plan are provided by manufacturer which may affect the validity of results, so it is manufacturer's responsibility to ensure that the apparatus meets the essential requirements of applied standards and in all the possible configurations as representative of its intended use.

**Limitation**

For the use of the authority's logo is limited unless the Test Standard(s)/Scope(s)/Item(s) mentioned in this test report is (are) included in the conformity assessment authorities acceptance respective.

Please note that the measurement uncertainty is provided for informational purpose only and are not use in determining the Pass/Fail results.

<b>Table of Contents</b>	<b>Page</b>
<b>REPORT ISSUED HISTORY</b>	<b>6</b>
<b>1 . SUMMARY OF TEST RESULTS</b>	<b>7</b>
1.1 TEST FACILITY	8
1.2 MEASUREMENT UNCERTAINTY	8
1.3 TEST ENVIRONMENT CONDITIONS	9
<b>2 . GENERAL INFORMATION</b>	<b>10</b>
2.1 GENERAL DESCRIPTION OF EUT	10
2.2 TEST MODES	12
2.3 PARAMETERS OF TEST SOFTWARE	14
2.4 DUTY CYCLE	15
2.5 BLOCK DIAGRAM SHOWING THE CONFIGURATION OF SYSTEM TESTED	17
2.6 SUPPORT UNITS	17
<b>3 . AC POWER LINE CONDUCTED EMISSIONS</b>	<b>18</b>
3.1 LIMIT	18
3.2 TEST PROCEDURE	18
3.3 DEVIATION FROM TEST STANDARD	18
3.4 TEST SETUP	19
3.5 EUT OPERATION CONDITIONS	19
3.6 TEST RESULTS	19
<b>4 . RADIATED EMISSIONS</b>	<b>20</b>
4.1 LIMIT	20
4.2 TEST PROCEDURE	21
4.3 DEVIATION FROM TEST STANDARD	22
4.4 TEST SETUP	22
4.5 EUT OPERATION CONDITIONS	23
4.6 TEST RESULTS - 9 KHZ TO 30 MHZ	23
4.7 TEST RESULTS - 30 MHZ TO 1000 MHZ	23
4.8 TEST RESULTS - ABOVE 1000 MHZ	23
<b>5 . BANDWIDTH</b>	<b>24</b>
5.1 LIMIT	24
5.2 TEST PROCEDURE	24
5.3 DEVIATION FROM STANDARD	24
5.4 TEST SETUP	25

<b>Table of Contents</b>	<b>Page</b>
5.5 EUT OPERATION CONDITIONS	25
5.6 TEST RESULTS	25
<b>6 . MAXIMUM OUTPUT POWER</b>	<b>26</b>
6.1 LIMIT	26
6.2 TEST PROCEDURE	26
6.3 DEVIATION FROM STANDARD	26
6.4 TEST SETUP	26
6.5 EUT OPERATION CONDITIONS	26
6.6 TEST RESULTS	26
<b>7 . POWER SPECTRAL DENSITY</b>	<b>27</b>
7.1 LIMIT	27
7.2 TEST PROCEDURE	27
7.3 DEVIATION FROM STANDARD	27
7.4 TEST SETUP	28
7.5 EUT OPERATION CONDITIONS	28
7.6 TEST RESULTS	28
<b>8 . FREQUENCY STABILITY</b>	<b>29</b>
8.1 LIMIT	29
8.2 TEST PROCEDURE	29
8.3 DEVIATION FROM STANDARD	29
8.4 TEST SETUP	29
8.5 EUT OPERATION CONDITIONS	29
8.6 TEST RESULTS	29
<b>9 . MEASUREMENT INSTRUMENTS LIST</b>	<b>30</b>
<b>10 . EUT TEST PHOTOS</b>	<b>33</b>
<b>APPENDIX A - AC POWER LINE CONDUCTED EMISSIONS</b>	<b>38</b>
<b>APPENDIX B - RADIATED EMISSION - 9 KHZ TO 30 MHZ</b>	<b>41</b>
<b>APPENDIX C - RADIATED EMISSION - 30 MHZ TO 1000 MHZ</b>	<b>46</b>
<b>APPENDIX D - RADIATED EMISSION - ABOVE 1000 MHZ</b>	<b>49</b>
<b>APPENDIX E - BANDWIDTH</b>	<b>122</b>
<b>APPENDIX F - MAXIMUM OUTPUT POWER</b>	<b>131</b>
<b>APPENDIX G - POWER SPECTRAL DENSITY</b>	<b>146</b>

<b>Table of Contents</b>	<b>Page</b>
<b>APPENDIX H - FREQUENCY STABILITY</b>	<b>159</b>

**REPORT ISSUED HISTORY**

Report Version	Description	Issued Date
R00	Original Issue.	Apr. 13, 2022

## 1. SUMMARY OF TEST RESULTS

Test procedures according to the technical standard(s):

FCC CFR Title 47, Part 15, Subpart E				
Standard(s) Section	Test Item	Test Result	Judgment	Remark
15.207 15.407(b)	AC Power Line Conducted Emissions	APPENDIX A	PASS	-----
15.407(b) 15.205(a) 15.209(a)	Radiated Emissions	APPENDIX B APPENDIX C APPENDIX D	PASS	-----
15.407(a) 15.407(e)	Bandwidth	APPENDIX E	PASS	-----
15.407(a)	Maximum Output Power	APPENDIX F	PASS	-----
15.407(a)	Power Spectral Density	APPENDIX G	PASS	-----
15.407(g)	Frequency Stability	APPENDIX H	PASS	-----
15.203	Antenna Requirements	-----	PASS	NOTE (2)
15.407(c)	Automatically Discontinue Transmission	-----	PASS	NOTE (3)

Note:

- (1) "N/A" denotes test is not applicable in this test report.
- (2) The device what use a permanently attached antenna were considered sufficient to comply with the provisions of 15.203.
- (3) During no any information transmission, the EUT can automatically discontinue transmission and become standby mode for power saving. the EUT can detect the controlling signal of ACK message transmitting from remote device and verify whether it shall resend or discontinue transmission.
- (4) For UNII-1 this device was functioned as a
  - Outdoor access point device
  - Indoor access point device
  - Fixed point-to-point access points device
  - Client device

## 1.1 TEST FACILITY

The test facilities used to collect the test data in this report is at the location of No. 3 Jinshagang 1st Rd. Shixia, Dalang Town Dongguan City, Guangdong 523792 People's Republic of China.

BTL's Registration Number for FCC: 357015

BTL's Designation Number for FCC: CN1240

## 1.2 MEASUREMENT UNCERTAINTY

ISO/IEC 17025 requires that an estimate of the measurement uncertainties associated with the emissions test results be included in the report. The measurement uncertainties given below are based on a 95% confidence level (based on a coverage factor (k=2))

The BTL measurement uncertainty as below table:

### A. AC power line conducted emissions test:

Test Site	Method	Measurement Frequency Range	U,(dB)
DG-C02	CISPR	150kHz ~ 30MHz	2.60

### B. Radiated emissions test:

Test Site	Method	Measurement Frequency Range	U,(dB)
DG-CB01	CISPR	9kHz ~ 30MHz	2.36

Test Site	Method	Measurement Frequency Range	Ant. H / V	U,(dB)
DG-CB03 (3m)	CISPR	30MHz ~ 200MHz	V	4.36
		30MHz ~ 200MHz	H	3.32
		200MHz ~ 1,000MHz	V	4.08
		200MHz ~ 1,000MHz	H	3.96

Test Site	Method	Measurement Frequency Range	U,(dB)
DG-CB02 (3m)	CISPR	1GHz ~ 6GHz	4.04
		6GHz ~ 18GHz	5.10

Test Site	Method	Measurement Frequency Range	U,(dB)
DG-CB02 (1m)	CISPR	18 ~ 26.5 GHz	3.62
		26.5 ~ 40 GHz	4.00

Test Site	Method	Measurement Frequency Range	U,(dB)
DG-CB03 (3m)	CISPR	1GHz ~ 6GHz	3.80
		6GHz ~ 18GHz	4.82

Test Site	Method	Measurement Frequency Range	U,(dB)
DG-CB03 (1m)	CISPR	18 ~ 26.5 GHz	3.62
		26.5 ~ 40 GHz	4.00



## C. Other Measurement test:

Test Item	Uncertainty
Bandwidth	±3.8 %
Maximum Output Power	±0.95 dB
Power Spectral Density	±0.86 dB
Frequency Stability	±0.16 dB
Temperature	±0.08 °C
Humidity	±1.5%

Note: Unless specifically mentioned, the uncertainty of measurement has not been taken into account to declare the compliance or non-compliance to the specification.

**1.3 TEST ENVIRONMENT CONDITIONS**

Test Item	Temperature	Humidity	Test Voltage	Tested By
AC Power Line Conducted Emissions	20°C	53%	AC 120V/60Hz	Rod Tang
Radiated Emissions-9kHz to 30MHz	17°C	59%	AC 120V/60Hz	Torocat Yuan
Radiated Emissions-30MHz to 1000MHz	18°C	59%	AC 120V/60Hz	Lang Chen
Radiated Emissions-Above 1000 MHz	21-26°C	52-58%	AC 120V/60Hz	Kwok Guo Meers Zhang
Bandwidth	22°C	50%	AC 120V/60Hz	Kwok Guo
Maximum Output Power	22.6-24.4°C	50.4-53.8 %	AC 120V/60Hz	Longdage Feng
Power Spectral Density	22°C	50%	AC 120V/60Hz	Kwok Guo
Frequency Stability	Normal & Extreme	50%	Normal & Extreme	Kwok Guo

## 2. GENERAL INFORMATION

### 2.1 GENERAL DESCRIPTION OF EUT

Equipment	AC1200 Wireless Gigabit Access Point
Brand Name	tp-link
Test Model	TL-WA1201
Series Model	N/A
Model Difference(s)	N/A
Power Source	1# DC voltage supplied from AC adapter. Model: T120150-2B1 2# Supplied from Ethernet port.
Power Rating	1# I/P: 100-240V~ 50/60Hz 0.6A O/P: 12V $\equiv$ 1.5A 2# DC 48V
Operation Frequency Band(s)	UNII-1: 5150 MHz ~ 5250 MHz UNII-3: 5725 MHz ~ 5850 MHz
Modulation Type	IEEE 802.11a/n/ac: OFDM
Bit Rate of Transmitter	IEEE 802.11a: 54/48/36/24/18/12/9/6 Mbps IEEE 802.11n: up to 300 Mbps IEEE 802.11ac: up to 866.7 Mbps
Maximum Output Power UNII-1 Non Beamforming	IEEE 802.11ac(VHT20): 23.60 dBm (0.2291 W)
Maximum Output Power UNII-3 Non Beamforming	IEEE 802.11ac(VHT80): 23.60 dBm (0.2291 W)
Maximum Output Power UNII-1 Beamforming	IEEE 802.11ac(VHT20): 23.18 dBm (0.2080 W)
Maximum Output Power UNII-3 Beamforming	IEEE 802.11ac(VHT80): 23.09 dBm (0.2037 W)

Note:

1. For a more detailed features description, please refer to the manufacturer's specifications or the user's manual.

#### 2. Channel List:

IEEE 802.11a IEEE 802.11n(HT20) IEEE 802.11ac(VHT20)		IEEE 802.11n(HT40) IEEE 802.11ac(VHT40)		IEEE 802.11ac(VHT80)	
UNII-1		UNII-1		UNII-1	
Channel	Frequency (MHz)	Channel	Frequency (MHz)	Channel	Frequency (MHz)
36	5180	38	5190	42	5210
40	5200	46	5230		
44	5220				
48	5240				

IEEE 802.11a IEEE 802.11n(HT20) IEEE 802.11ac(VHT20)		IEEE 802.11n(HT40) IEEE 802.11ac(VHT40)		IEEE 802.11ac(VHT80)	
UNII-3		UNII-3		UNII-3	
Channel	Frequency (MHz)	Channel	Frequency (MHz)	Channel	Frequency (MHz)
149	5745	151	5755	155	5775
153	5765	159	5795		
157	5785				
161	5805				
165	5825				

## 3. Antenna Specification:

Ant.	Brand	P/N	Antenna Type	Connector	Gain (dBi)	Note
1	tp-link	3101504484	Omni	Weld	3	TX/RX
2	tp-link	3101504485	Omni	Weld	3	TX/RX
3	tp-link	5G Antenna_TL-WA1201(3.0)	IFA	N/A	2.89	RX

Note:

- 1) This EUT supports CDD, and all antennas have the same gain, Directional gain =  $G_{ANT} + \text{Array Gain}$ .  
 For power measurements, Array Gain=0dB ( $N_{ANT} \leq 4$ ), so the Directional gain=3 dBi.  
 For power spectral density measurements,  $N_{ANT}=2$ ,  $N_{SS} = 1$ .  
 So the Directional gain= $G_{ANT} + \text{Array Gain} = G_{ANT} + 10\log(N_{ANT}/N_{SS})\text{dBi} = 3 + 10\log(2/1)\text{dBi} = 6.01\text{ dBi}$ .  
 Then, the UNII-1 power spectral density limit is  $17 - (6.01 - 6) = 16.99\text{ dBm/MHz}$ , the UNII-3 power spectral density limit is  $30 - (6.01 - 6) = 29.99\text{ dBm/500 kHz}$ .
- 2) Beamforming Gain: 3 dB. so the Directional gain=3+3=6 dBi.
- 3) The antenna gain and beamforming gain are provided by the manufacturer.

## 4. Table for Antenna Configuration:

For Non Beamforming:

Operating Mode	TX Mode	2TX
IEEE 802.11a		V (Ant. 1+Ant. 2)
IEEE 802.11n(HT20)		V (Ant. 1+Ant. 2)
IEEE 802.11n(HT40)		V (Ant. 1+Ant. 2)
IEEE 802.11ac(VHT20)		V (Ant. 1+Ant. 2)
IEEE 802.11ac(VHT40)		V (Ant. 1+Ant. 2)
IEEE 802.11ac(VHT80)		V (Ant. 1+Ant. 2)

For Beamforming:

Operating Mode	TX Mode	2TX
IEEE 802.11n(HT20)		V (Ant. 1+Ant. 2)
IEEE 802.11n(HT40)		V (Ant. 1+Ant. 2)
IEEE 802.11ac(VHT20)		V (Ant. 1+Ant. 2)
IEEE 802.11ac(VHT40)		V (Ant. 1+Ant. 2)
IEEE 802.11ac(VHT80)		V (Ant. 1+Ant. 2)

## 2.2 TEST MODES

The test system was pre-tested based on the consideration of all possible combinations of EUT operation mode.

Pretest Mode	Description
Mode 1	TX A Mode Channel 36/40/48 (UNII-1)
Mode 2	TX AC(VHT20) Mode Channel 36/40/48 (UNII-1)
Mode 3	TX AC(VHT40) Mode Channel 38/46 (UNII-1)
Mode 4	TX AC(VHT80) Mode Channel 42 (UNII-1)
Mode 5	TX A Mode Channel 149/157/165 (UNII-3)
Mode 6	TX AC(VHT20) Mode Channel 149/157/165 (UNII-3)
Mode 7	TX AC(VHT40) Mode Channel 151/159 (UNII-3)
Mode 8	TX AC(VHT80) Mode Channel 155 (UNII-3)
Mode 9	TX AC(VHT20) Mode Channel 48 (UNII-1)

Following mode(s) was (were) found to be the worst case(s) and selected for the final test.

<b>AC power line conducted emissions test</b>	
Final Test Mode	Description
Mode 9	TX AC(VHT20) Mode Channel 48 (UNII-1)

<b>Radiated Emissions Test - Below 1GHz</b>	
Final Test Mode	Description
Mode 9	TX AC(VHT20) Mode Channel 48 (UNII-1)

<b>Radiated Emissions Test - Above 1GHz_Non Beamforming</b>	
Final Test Mode	Description
Mode 1	TX A Mode Channel 36/40/48 (UNII-1)
Mode 2	TX AC(VHT20) Mode Channel 36/40/48 (UNII-1)
Mode 3	TX AC(VHT40) Mode Channel 38/46 (UNII-1)
Mode 4	TX AC(VHT80) Mode Channel 42 (UNII-1)
Mode 5	TX A Mode Channel 149/157/165 (UNII-3)
Mode 6	TX AC(VHT20) Mode Channel 149/157/165 (UNII-3)
Mode 7	TX AC(VHT40) Mode Channel 151/159 (UNII-3)
Mode 8	TX AC(VHT80) Mode Channel 155 (UNII-3)

<b>Maximum Output Power Test_Non Beamforming</b>	
Final Test Mode	Description
Mode 1	TX A Mode Channel 36/40/48 (UNII-1)
Mode 2	TX AC(VHT20) Mode Channel 36/40/48 (UNII-1)
Mode 3	TX AC(VHT40) Mode Channel 38/46 (UNII-1)
Mode 4	TX AC(VHT80) Mode Channel 42 (UNII-1)
Mode 5	TX A Mode Channel 149/157/165 (UNII-3)
Mode 6	TX AC(VHT20) Mode Channel 149/157/165 (UNII-3)
Mode 7	TX AC(VHT40) Mode Channel 151/159 (UNII-3)
Mode 8	TX AC(VHT80) Mode Channel 155 (UNII-3)

<b>Maximum Output Power Test_Beamforming</b>	
Final Test Mode	Description
Mode 2	TX AC(VHT20) Mode Channel 36/40/48 (UNII-1)
Mode 3	TX AC(VHT40) Mode Channel 38/46 (UNII-1)
Mode 4	TX AC(VHT80) Mode Channel 42 (UNII-1)
Mode 6	TX AC(VHT20) Mode Channel 149/157/165 (UNII-3)
Mode 7	TX AC(VHT40) Mode Channel 151/159 (UNII-3)
Mode 8	TX AC(VHT80) Mode Channel 155 (UNII-3)

<b>Other Conducted Test_Non Beamforming</b>	
Final Test Mode	Description
Mode 1	TX A Mode Channel 36/40/48 (UNII-1)
Mode 2	TX AC(VHT20) Mode Channel 36/40/48 (UNII-1)
Mode 3	TX AC(VHT40) Mode Channel 38/46 (UNII-1)
Mode 4	TX AC(VHT80) Mode Channel 42 (UNII-1)
Mode 5	TX A Mode Channel 149/157/165 (UNII-3)
Mode 6	TX AC(VHT20) Mode Channel 149/157/165 (UNII-3)
Mode 7	TX AC(VHT40) Mode Channel 151/159 (UNII-3)
Mode 8	TX AC(VHT80) Mode Channel 155 (UNII-3)

**Note:**

- (1) For AC power line conducted emissions and radiated emission below 1 GHz test, the TX AC(VHT20) Mode Channel 48 (UNII-1) is found to be the worst case and recorded.
- (2) For radiated emission above 1 GHz test, the spurious points of 1GHz~26.5GHz and 26.5GHz~40GHz have been pre-tested and in this report only recorded the worst case. The remaining spurious points are all below the limit value of 20dB.
- (3) All the bit rate of transmitter have been tested and found the lowest rate is found to be the worst case and recorded.
- (4) VHT20/VHT40 covers HT20/HT40, due to same modulation. The power setting for 802.11n HT20 and HT40 are the same or lower than 802.11ac VHT20 and VHT40.
- (5) The measurements for Output Power are tested, the Non Beamforming and Beamforming are recorded in the report. The worst case is Non Beamforming and only the worst case is documented for other test items.

**2.3 PARAMETERS OF TEST SOFTWARE**

Test Software Version	IPOP_V4.0
-----------------------	-----------

## 2.4 DUTY CYCLE

If duty cycle is  $\geq 98\%$ , duty factor is not required.

If duty cycle is  $< 98\%$ , duty factor shall be considered.

The output power = measured power + duty factor.

The power spectral density = measured power spectral density + duty factor.

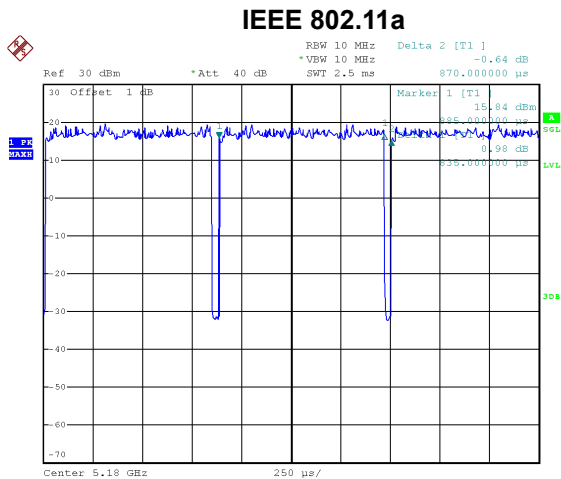

Date: 20.JAN.2022 00:36:01

Duty cycle =  $0.835 \text{ ms} / 0.870 \text{ ms} = 95.98\%$   
 Duty Factor =  $10 \log(1 / \text{Duty cycle}) = 0.18$

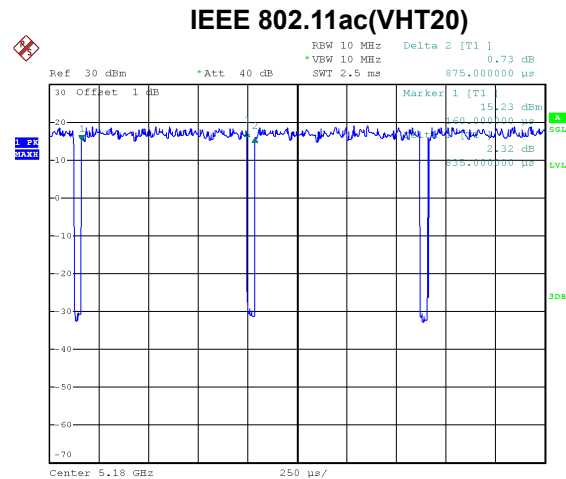

Date: 20.JAN.2022 00:37:16

Duty cycle =  $0.835 \text{ ms} / 0.875 \text{ ms} = 95.43\%$   
 Duty Factor =  $10 \log(1 / \text{Duty cycle}) = 0.20$

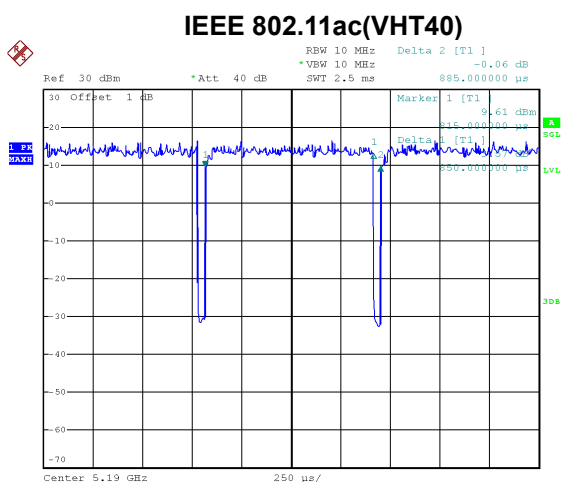

Date: 20.JAN.2022 00:38:06

Duty cycle =  $0.850 \text{ ms} / 0.885 \text{ ms} = 96.05\%$   
 Duty Factor =  $10 \log(1 / \text{Duty cycle}) = 0.18$

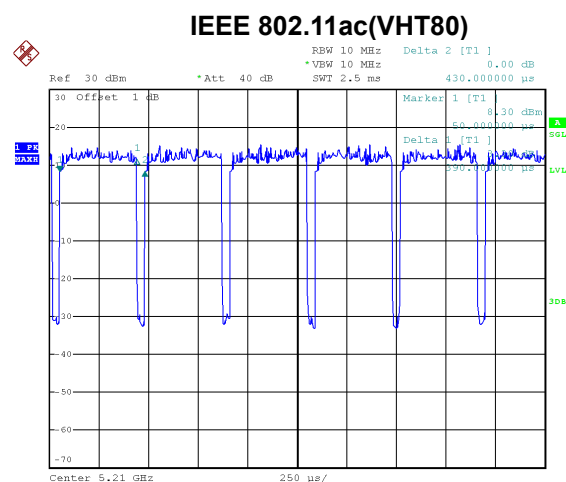

Date: 20.JAN.2022 00:42:34

Duty cycle =  $0.390 \text{ ms} / 0.430 \text{ ms} = 90.70\%$   
 Duty Factor =  $10 \log(1 / \text{Duty cycle}) = 0.42$

**NOTE:**

For IEEE 802.11a:

For radiated emissions frequency above 1 GHz, the resolution bandwidth of test receiver/spectrum analyzer is 1 MHz and the video bandwidth is 1198 Hz (Duty cycle < 98%).

For IEEE 802.11ac(VHT20):

For radiated emissions frequency above 1 GHz, the resolution bandwidth of test receiver/spectrum analyzer is 1 MHz and the video bandwidth is 1198 Hz (Duty cycle < 98%).

For IEEE 802.11ac(VHT40):

For radiated emissions frequency above 1 GHz, the resolution bandwidth of test receiver/spectrum analyzer is 1 MHz and the video bandwidth is 1176 Hz (Duty cycle < 98%).

For IEEE 802.11ac(VHT80):

For radiated emissions frequency above 1 GHz, the resolution bandwidth of test receiver/spectrum analyzer is 1 MHz and the video bandwidth is 2564 Hz (Duty cycle < 98%).



## 2.5 BLOCK DIAGRAM SHOWING THE CONFIGURATION OF SYSTEM TESTED

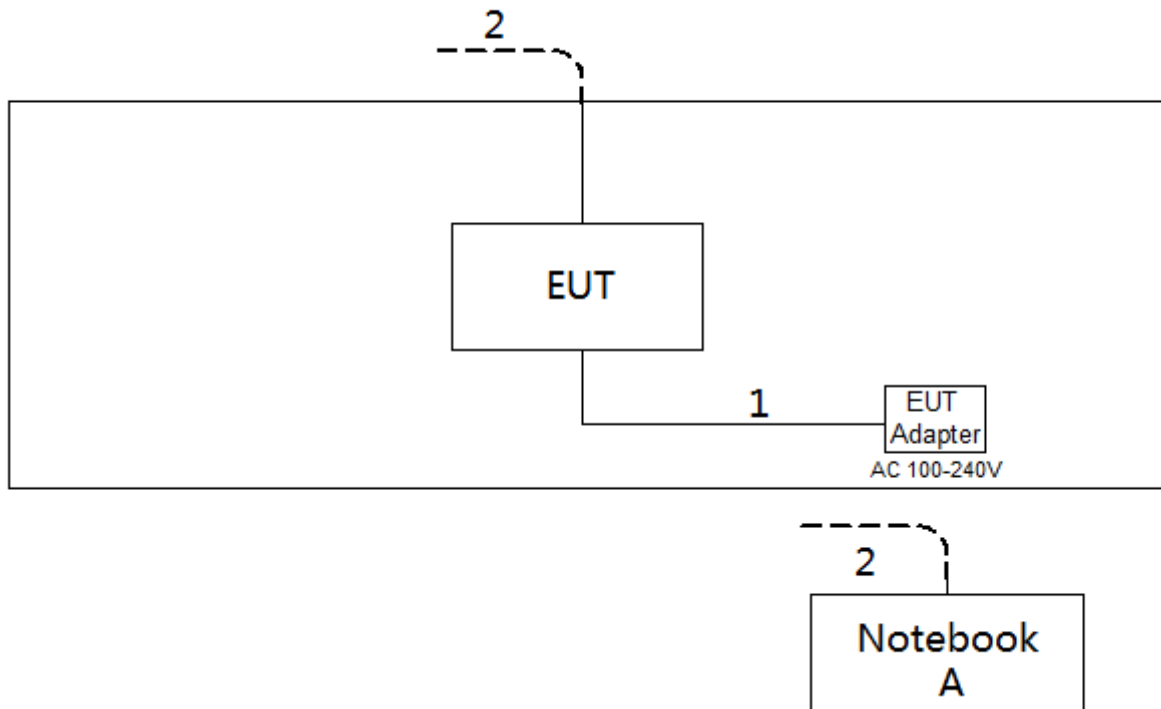

## 2.6 SUPPORT UNITS

Item	Equipment	Brand	Model No.	Series No.
A	Notebook	Dell	Inspiron 15-7559	N/A

Item	Cable Type	Shielded Type	Ferrite Core	Length
1	DC Cable	NO	NO	1.5m
2	RJ45 Cable	NO	NO	10m

### 3. AC POWER LINE CONDUCTED EMISSIONS

#### 3.1 LIMIT

Frequency (MHz)	Limit (dB $\mu$ V)	
	Quasi-peak	Average
0.15 - 0.5	66 to 56*	56 to 46*
0.5 - 5.0	56	46
5.0 - 30.0	60	50

**NOTE:**

- (1) The tighter limit applies at the band edges.
- (2) The limit of " \* " marked band means the limitation decreases linearly with the logarithm of the frequency in the range.

#### 3.2 TEST PROCEDURE

- a. The EUT was placed 0.8 meters from the horizontal ground plane with EUT being connected to the power mains through a line impedance stabilization network (LISN). All other support equipment powered from additional LISN(s). The LISN provide 50 Ohm/ 50uH of coupling impedance for the measuring instrument.
- b. Interconnecting cables that hang closer than 40 cm to the ground plane shall be folded back and forth in the center forming a bundle 30 to 40 cm long.
- c. I/O cables that are not connected to a peripheral shall be bundled in the center. The end of the cable may be terminated, if required, using the correct terminating impedance. The overall length shall not exceed 1 m.
- d. LISN at least 80 cm from nearest part of EUT chassis.
- e. For the actual test configuration, please refer to the related Item -EUT Test Photos.

The following table is the setting of the receiver:

Receiver Parameter	Setting
Start Frequency	0.15 MHz
Stop Frequency	30 MHz
IF Bandwidth	9 kHz

#### 3.3 DEVIATION FROM TEST STANDARD

No deviation

### 3.4 TEST SETUP

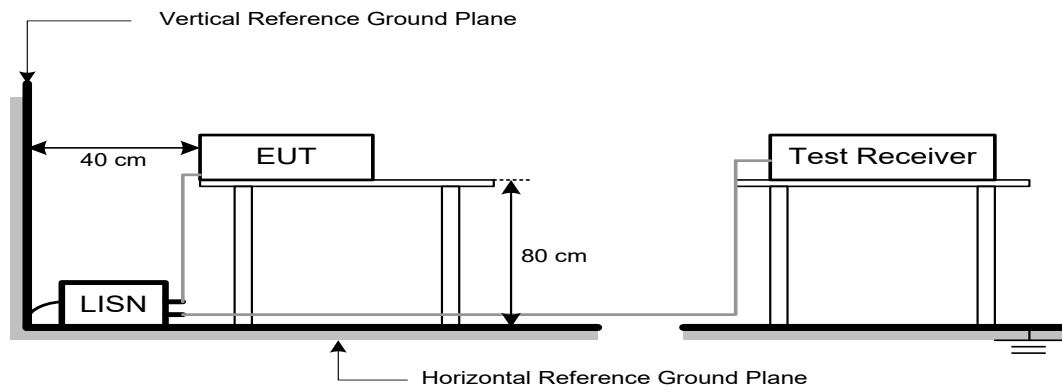

### 3.5 EUT OPERATION CONDITIONS

The EUT was configured for testing in a typical fashion (as a customer would normally use it). The EUT has been programmed to continuously transmit during test. This operating condition was tested and used to collect the included data.

The EUT was programmed to be in continuously transmitting/TX mode.

### 3.6 TEST RESULTS

Please refer to the APPENDIX A.

## 4. RADIATED EMISSIONS

### 4.1 LIMIT

In case the emission fall within the restricted band specified on 15.205(a), then the 15.209(a) limit in the table below has to be followed.

#### LIMITS OF RADIATED EMISSIONS MEASUREMENT (9 kHz to 1000 MHz)

Frequency (MHz)	Field Strength (microvolts/meter)	Measurement Distance (meters)
0.009-0.490	2400/F(kHz)	300
0.490-1.705	24000/F(kHz)	30
1.705-30.0	30	30
30-88	100	3
88-216	150	3
216-960	200	3
Above 960	500	3

#### LIMITS OF UNWANTED EMISSION OUT OF THE RESTRICTED BANDS (Above 1000 MHz)

Frequency (MHz)	EIRP Limit (dBm/MHz)	Equivalent Field Strength at 3m (dBμV/m)
5150-5250	-27	68.2
5725-5850 NOTE (2)	-27	68.2
	10	105.2
	15.6	110.8
	27	122.2

#### NOTE:

- (1) The following formula is used to convert the equipment isotropic radiated power (eirp) to field strength:

$$E = \frac{1000000\sqrt{30P}}{3} \mu\text{V/m, where P is the eirp (Watts)}$$

- (2) According to 15.407(b)(4)(i), all emissions shall be limited to a level of -27 dBm/MHz at 75 MHz or more above or below the band edge increasing linearly to 10 dBm/MHz at 25 MHz above or below the band edge, and from 25 MHz above or below the band edge increasing linearly to a level of 15.6 dBm/MHz at 5 MHz above or below the band edge, and from 5 MHz above or below the band edge increasing linearly to a level of 27 dBm/MHz at the band edge.

## 4.2 TEST PROCEDURE

- a. The measuring distance of 3 m shall be used for measurements. The EUT was placed on the top of a rotating table 0.8 meter above the ground at a 3 meter semi-anechoic chamber. The table was rotated 360 degrees to determine the position of the highest radiation.(below 1GHz)
- b. The measuring distance of 3 m shall be used for measurements. The EUT was placed on the top of a rotating table 1.5 meter above the ground at a 3 meter semi-anechoic chamber. The table was rotated 360 degrees to determine the position of the highest radiation.(above 1GHz)
- c. The height of the equipment or of the substitution antenna shall be 0.8m or 1.5m; the height of the test antenna shall vary between 1 m to 4 m. Both horizontal and vertical polarizations of the antenna are set to make the measurement.
- d. For each suspected emission, the EUT was arranged to its worst case and then the antenna was tuned to heights find the maximum reading (used Bore sight function).
- e. The receiver system was set to peak and average detect function and specified bandwidth with maximum hold mode when the test frequency is above 1 GHz.
- f. The initial step in collecting radiated emission data is a receiver peak detector mode pre-scanning the measurement frequency range. Significant peaks are then marked and then Quasi Peak detector mode re-measured.
- g. All readings are Peak unless otherwise stated QP in column of Note. Peak denotes that the Peak reading compliance with the QP Limits and then QP Mode measurement didn't perform. (below 1 GHz)
- h. All readings are Peak Mode value unless otherwise stated AVG in column of Note. If the Peak Mode Measured value compliance with the Peak Limits and lower than AVG Limits, the EUT shall be deemed to meet both Peak & AVG Limits and then only Peak Mode was measured, but AVG Mode didn't perform. (above 1 GHz)
- i. For the actual test configuration, please refer to the related Item –EUT Test Photos.

The following table is the setting of the receiver:

Spectrum Parameters	Setting
Start ~ Stop Frequency	9 kHz~150 kHz for RBW 200 Hz
Start ~ Stop Frequency	0.15 MHz~30 MHz for RBW 9 kHz
Start ~ Stop Frequency	30 MHz~1000 MHz for RBW 100 kHz

Spectrum Parameters	Setting
Start Frequency	1000 MHz
Stop Frequency	10th carrier harmonic or 40 GHz, whichever is lower
RBW / VBW (Emission in restricted band)	1 MHz / 3 MHz for PK value 1 MHz / 1/T Hz for AVG value

Receiver Parameters	Setting
Start ~ Stop Frequency	9 kHz~90 kHz for PK/AVG detector
Start ~ Stop Frequency	90 kHz~110 kHz for QP detector
Start ~ Stop Frequency	110 kHz~490 kHz for PK/AVG detector
Start ~ Stop Frequency	490 kHz~30 MHz for QP detector
Start ~ Stop Frequency	30 MHz~1000 MHz for QP detector
Start ~ Stop Frequency	1 GHz~40 GHz for PK/AVG detector

### 4.3 DEVIATION FROM TEST STANDARD

No deviation.

### 4.4 TEST SETUP

#### 9 kHz to 30 MHz

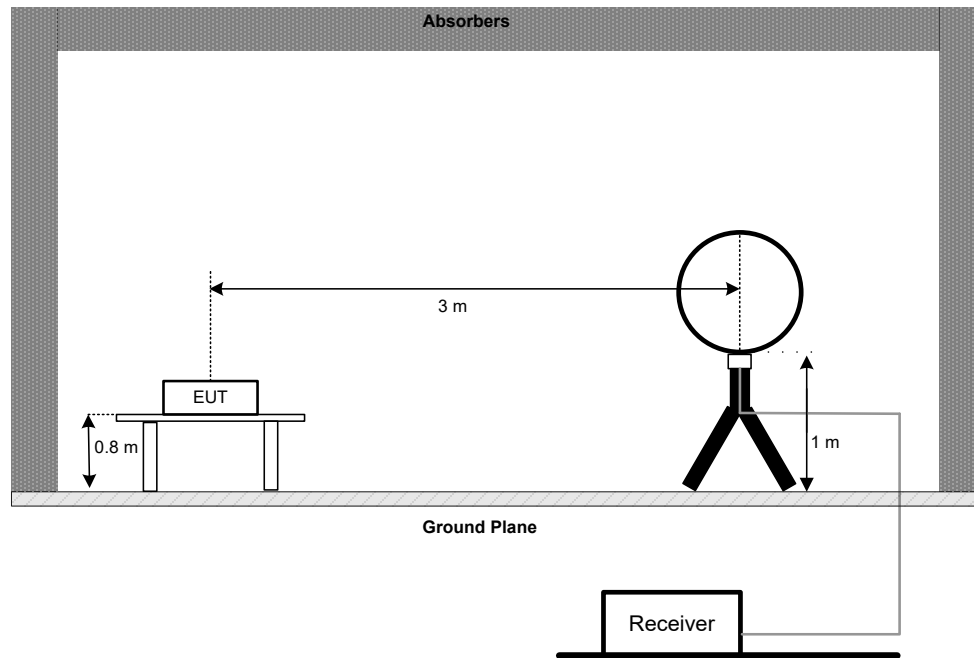

#### 30 MHz to 1 GHz

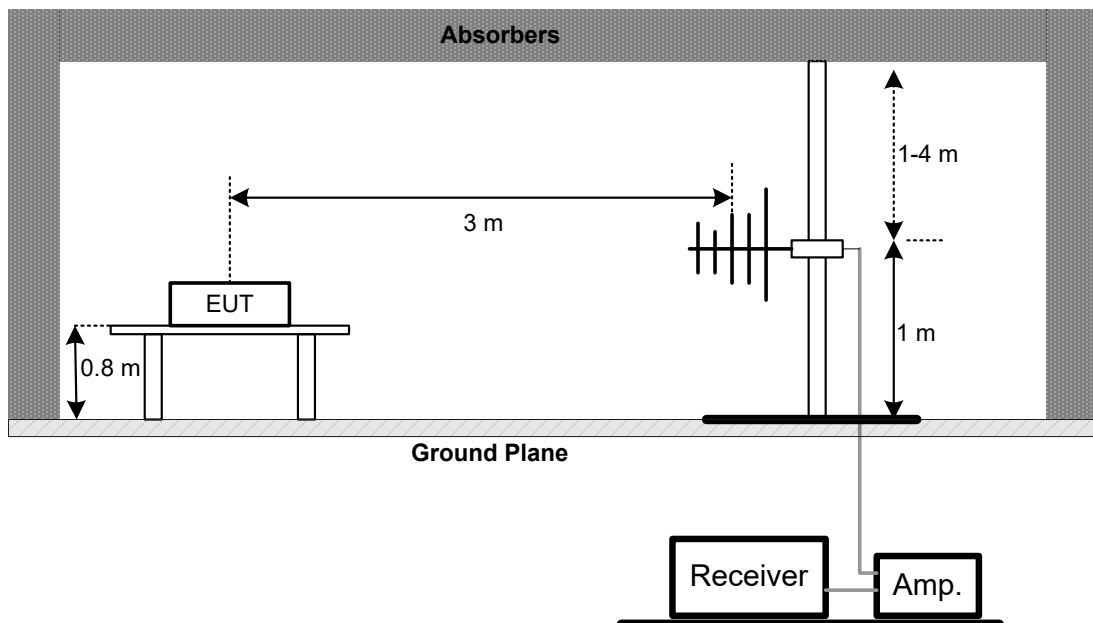

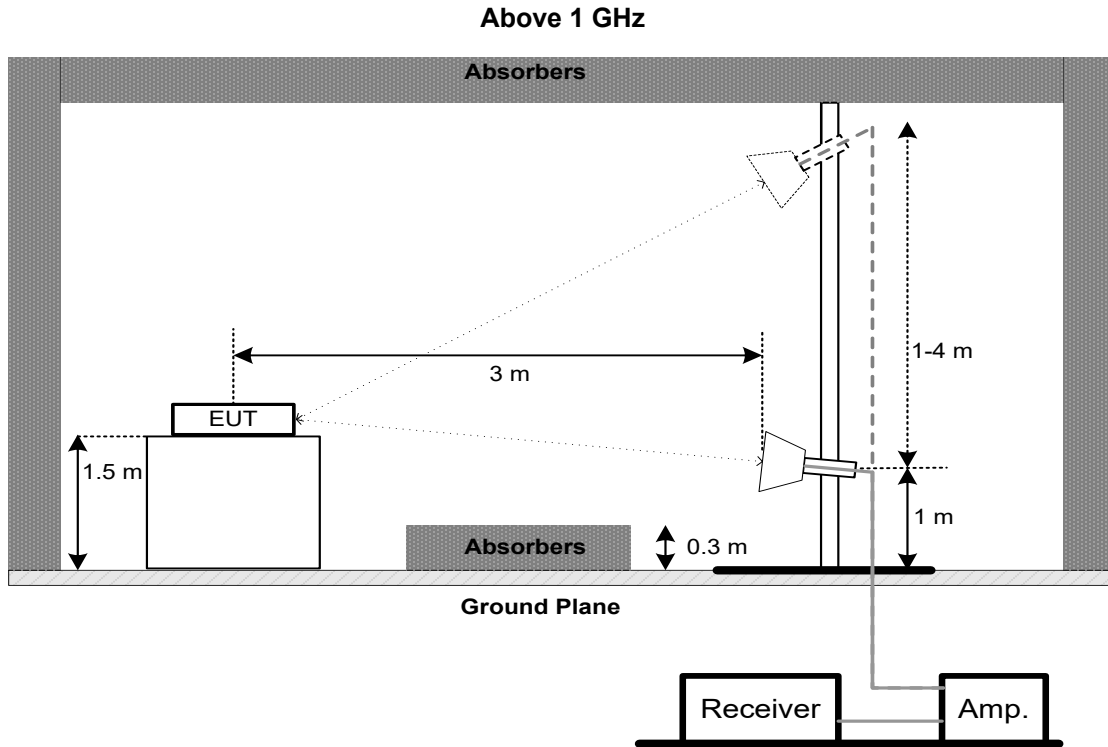

#### 4.5 EUT OPERATION CONDITIONS

The EUT tested system was configured as the statements of 3.5 unless otherwise a special operating condition is specified in the follows during the testing.

#### 4.6 TEST RESULTS - 9 KHZ TO 30 MHZ

Please refer to the APPENDIX B.

Remark:

- (1) Distance extrapolation factor =  $40 \log (\text{specific distance} / \text{test distance})$  (dB).
- (2) Limit line = specific limits (dBuV) + distance extrapolation factor.

#### 4.7 TEST RESULTS - 30 MHZ TO 1000 MHZ

Please refer to the APPENDIX C.

#### 4.8 TEST RESULTS - ABOVE 1000 MHZ

Please refer to the APPENDIX D.

Remark:

- (1) No limit: This is fundamental signal, the judgment is not applicable.  
For fundamental signal judgment was referred to Peak output test.

## 5. BANDWIDTH

### 5.1 LIMIT

Section	Test Item	Limit	Frequency Range (MHz)
FCC 15.407(a)	26 dB Bandwidth	-	5150-5250
FCC 15.407(e)	6 dB Bandwidth	Minimum 500 kHz	5725-5850

### 5.2 TEST PROCEDURE

a. The EUT was directly connected to the spectrum analyzer and antenna output port as show in the block diagram below

b. Spectrum Setting:

For UNII-1:

Spectrum Parameter	Setting
Span Frequency	> 26 dB Bandwidth
RBW	Appromiximately 1% of the emission bandwidth
VBW	> RBW
Detector	Peak
Trace	Max Hold
Sweep Time	Auto

For UNII-3:

Spectrum Parameter	Setting
Span Frequency	> 6 dB Bandwidth
RBW	100 kHz
VBW	300 kHz
Detector	Peak
Trace	Max Hold
Sweep Time	Auto

For 99% Occupied Bandwidth:

Spectrum Parameter	Setting
Span Frequency	1.5 times to 5 times the OBW
RBW	1% to 5% of the OBW
VBW	$\geq 3 \cdot \text{RBW}$
Detector	Peak
Trace	Max Hold
Sweep Time	Auto

c. Measured the spectrum width with power higher than 26 dB / 6 dB below carrier.

### 5.3 DEVIATION FROM STANDARD

No deviation.

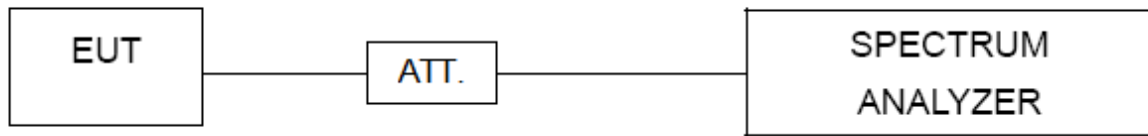

**5.4 TEST SETUP****5.5 EUT OPERATION CONDITIONS**

The EUT was programmed to be in continuously transmitting mode.

**5.6 TEST RESULTS**

Please refer to the APPENDIX E.

## 6. MAXIMUM OUTPUT POWER

### 6.1 LIMIT

Section	Test Item	Limit	Frequency Range (MHz)
FCC 15.407(a)	Maximum Output Power	AP device: 1 Watt (30 dBm) Client device: 250 mW (23.98 dBm)	5150-5250
		1 Watt (30dBm)	5725-5850

Note:

- a. For an indoor access point operating in the band 5.15-5.25 GHz, the maximum conducted output power over the frequency band of operation shall not exceed 1 W provided the maximum antenna gain does not exceed 6 dBi. In addition, the maximum power spectral density shall not exceed 17 dBm in any 1 megahertz band. If transmitting antennas of directional gain greater than 6 dBi are used, both the maximum conducted output power and the maximum power spectral density shall be reduced by the amount in dB that the directional gain of the antenna exceeds 6 dBi.

### 6.2 TEST PROCEDURE

- a. The EUT was directly connected to the power meter and antenna output port as show in the block diagram below.
- b. Test test was performed in accordance with method of FCC KDB 789033 D02 General UNII Test Procedures New Rules v02r01.

### 6.3 DEVIATION FROM STANDARD

No deviation.

### 6.4 TEST SETUP

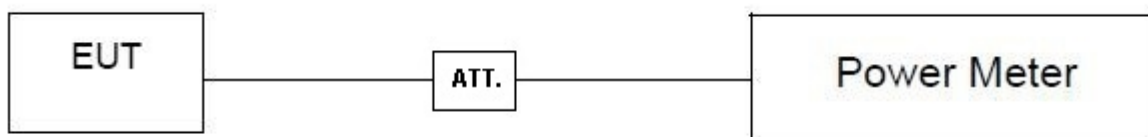

### 6.5 EUT OPERATION CONDITIONS

The EUT was programmed to be in continuously transmitting mode.

### 6.6 TEST RESULTS

Please refer to the APPENDIX F.

## 7. POWER SPECTRAL DENSITY

### 7.1 LIMIT

Section	Test Item	Limit	Frequency Range (MHz)
FCC 15.407(a)	Power Spectral Density	AP device: 17 dBm/MHz Client device: 11 dBm/MHz	5150-5250
		30 dBm/500 kHz	5725-5850

### 7.2 TEST PROCEDURE

- a. The EUT was directly connected to the spectrum analyzer and antenna output port as show in the block diagram below.
- b. Spectrum Setting:

For UNII-1:

Spectrum Parameter	Setting
Span Frequency	Encompass the entire emissions bandwidth (EBW) of the signal
RBW	1 MHz.
VBW	3 MHz.
Detector	RMS
Trace average	100 trace
Sweep Time	Auto

For UNII-3:

Spectrum Parameter	Setting
Span Frequency	Encompass the entire emissions bandwidth (EBW) of the signal
RBW	100 kHz.
VBW	300 kHz.
Detector	RMS
Trace average	100 trace
Sweep Time	Auto

Note:

1. For UNII-3, according to KDB publication 789033 D02 General UNII Test Procedures New Rules v02r01, section II.F.5., it is acceptable to set RBW at 100kHz and VBW at 300kHz if the spectrum analyzer does not have 500 kHz RBW. Then, add  $10 \log (500 \text{ kHz}/100 \text{ kHz})$  to the measured result, i.e. 7 dB.
2. During the test of U-NII 3 PSD, the measurement result with RBW=100kHz has been added 7 dB by compensating offset. For example, the cable loss is 13 dB, and the final offset is  $13 + 7 = 20 \text{ dB}$  when RBW=100kHz is used.

### 7.3 DEVIATION FROM STANDARD

No deviation.

#### 7.4 TEST SETUP



#### 7.5 EUT OPERATION CONDITIONS

The EUT was programmed to be in continuously transmitting mode.

#### 7.6 TEST RESULTS

Please refer to the APPENDIX G.

## 8. FREQUENCY STABILITY

### 8.1 LIMIT

Section	Test Item	Limit	Frequency Range (MHz)
FCC 15.407(g)	Frequency Stability	An emission is maintained within the band of operation under all conditions of normal operation as specified in the users manual.	5150-5250
			5725-5850

### 8.2 TEST PROCEDURE

- a. The EUT was directly connected to the spectrum analyzer and antenna output port as show in the block diagram below.
- b. Spectrum Setting:

Spectrum Parameter	Setting
Span Frequency	Entire absence of modulation emissions bandwidth
RBW	10 kHz
VBW	10 kHz
Detector	Peak
Trace	Max Hold
Sweep Time	Auto

- c. The test extreme voltage is to change the primary supply voltage from 85 to 115 percent of the nominal value.
- d. User manual temperature is 0°C~40°C.

### 8.3 DEVIATION FROM STANDARD

No deviation.

### 8.4 TEST SETUP

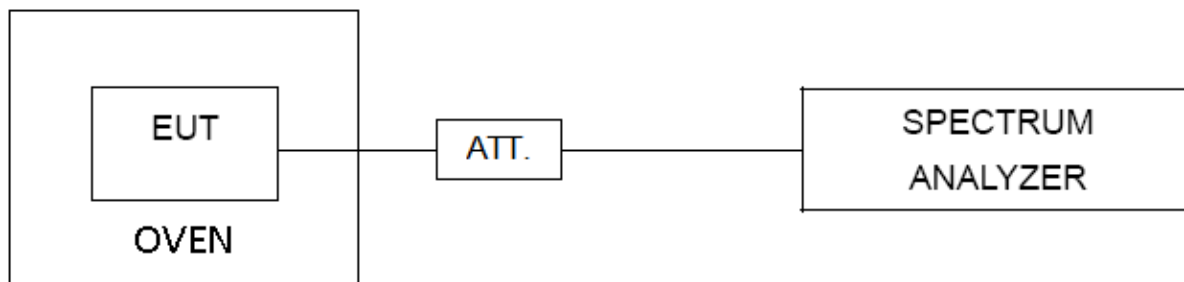

### 8.5 EUT OPERATION CONDITIONS

The EUT was programmed to be in continuously transmitting mode.

### 8.6 TEST RESULTS

Please refer to the APPENDIX H.

**9. MEASUREMENT INSTRUMENTS LIST**

AC Power Line Conducted Emissions					
Item	Kind of Equipment	Manufacturer	Type No.	Serial No.	Calibrated until
1	EMI Test Receiver	R&S	ESCI	100382	Jan. 22, 2022 Jan. 22, 2023
2	LISN	EMCO	3816/2	52765	Jan. 23, 2022 Jan. 23, 2023
3	TWO-LINE V-NETWORK	R&S	ENV216	101447	Jan. 23, 2022 Jan. 23, 2023
4	50Ω Terminator	SHX	TF5-3	15041305	N/A
5	Measurement Software	Farad	EZ-EMC Ver.NB-03A1-01	N/A	N/A
6	Cable	N/A	RG223	12m	Mar. 08, 2022 Mar. 08, 2023
7	643 Shield Room	ETS	6*4*3	N/A	N/A

Radiated Emissions - 9 kHz to 30 MHz					
Item	Kind of Equipment	Manufacturer	Type No.	Serial No.	Calibrated until
1	MXE EMI Receiver	Keysight	N9038A	MY56400091	Jan. 22, 2022 Jan. 22, 2023
2*	Active Loop Antenna	R&S	HFH2-Z2	830749/020	Aug. 23, 2024
3	Cable	N/A	RG 213/U(9kHz~1GHz)	N/A	May 27, 2022
4	Measurement Software	Farad	EZ-EMC Ver.NB-03A1-01	N/A	N/A
5	966 Chamber Room	ETS	9*6*6	N/A	Jul. 17, 2022

Radiated Emissions - 30 MHz to 1 GHz					
Item	Kind of Equipment	Manufacturer	Type No.	Serial No.	Calibrated until
1	Antenna	Schwarzbeck	VULB9160	9160-3232	Mar. 03, 2022 Mar. 03, 2023
2	Amplifier	HP	8447D	2944A08742	Jan. 22, 2022 Jan. 22, 2023
3	Cable	emci	LMR-400	N/A	Nov. 30, 2022
4	Controller	CT	SC100	N/A	N/A
5	Controller	MF	MF-7802	MF780208416	N/A
6	Receiver	Agilent	N9038A	MY52130039	Jan. 22, 2022 Jan. 22, 2023
7	Measurement Software	Farad	EZ-EMC Ver.NB-03A1-01	N/A	N/A
8	966 Chamber Room	RM	9*6*6	N/A	Jul. 24, 2022

Radiated Emissions - Above 1 GHz					
Item	Kind of Equipment	Manufacturer	Type No.	Serial No.	Calibrated until
1	Double Ridged Guide Antenna	ETS	3115	75789	May 10, 2022
2	Amplifier	Agilent	8449B	3008A02334	Jan. 22, 2022 Jan. 22, 2023
3	Cable	mitron	RWLP50-4.0A-KJ-S MSM-12M	N/A	Sep. 23, 2022
4	Controller	MF	MF-7802BS	N/A	N/A
5	Broad-Band Horn Antenna	Schwarzbeck	BBHA 9170	9170319	Jun. 30, 2022
6	Low Noise Amplifier	CONNPHY	CLN-18G40G-4330 -K	619413	Jul. 16, 2022
7	Cable	Talent microwave	A40-2.92M2.92M-2.5M	N/A	Nov. 30, 2022
8	EXA Spectrum Analyzer	Keysight	N9010A	MY56480488	Jan. 22, 2022 Jan. 22, 2023
9*	Band Reject Filter	Micro-Tronics	BRC50703-01	7	Feb. 27, 2024
10*	Band Reject Filter	Micro-Tronics	BRC50705-01	10	Feb. 27, 2024
11	Measurement Software	Farad	EZ-EMC Ver.NB-03A1-01	N/A	N/A
12	1266 Chamber Room	RM	12*6*6	N/A	Jul. 03, 2022

Radiated Emissions - Above 1 GHz					
Item	Kind of Equipment	Manufacturer	Type No.	Serial No.	Calibrated until
1	Double Ridged Horn Antenna	ARA	DRG-118A	16554	Apr. 21, 2022
2	Broad-Band Horn Antenna	Schwarzbeck	BBHA 9170	9170319	Jun. 30, 2022
3	Amplifier	Agilent	8449B	3008A02584	Jul. 10, 2022
4	Controller	CT	SC100	N/A	N/A
5	Controller	MF	MF-7802	MF780208416	N/A
6	Receiver	Agilent	N9038A	MY52130039	Jan. 22, 2022 Jan. 22, 2023
7	EXA Spectrum Analyzer	Keysight	N9010A	MY56480488	Jan. 22, 2022 Jan. 22, 2023
8	Low Noise Amplifier	CONNPHY	CLN-18G40G-4330 -K	619413	Jul. 16, 2022
9	Cable	Talent microwave	A81-SMAMSMAM-12.5M	N/A	Oct. 15, 2022
10	Cable	Talent microwave	A40-2.92M2.92M-2.5M	N/A	Nov. 30, 2022
11*	Band Reject Filter	Micro-Tronics	BRC50703-01	7	Feb. 27, 2024
12*	Band Reject Filter	Micro-Tronics	BRC50705-01	10	Feb. 27, 2024
13	Measurement Software	Farad	EZ-EMC Ver.NB-03A1-01	N/A	N/A
14	966 Chamber Room	RM	9*6*6	N/A	Jul. 24, 2022

Bandwidth & Power Spectral Density					
Item	Kind of Equipment	Manufacturer	Type No.	Serial No.	Calibrated until
1	Spectrum Analyzer	R&S	FSP40	100185	Jul. 10, 2022
2	Attenuator	WOKEN	6SM3502	VAS1214NL	N/A
3	RF Cable	Tongkaichuan	N/A	N/A	N/A
4	DC Block	Mini	N/A	N/A	N/A

Maximum Output Power					
Item	Kind of Equipment	Manufacturer	Type No.	Serial No.	Calibrated until
1	Peak Power Analyzer	Keysight	8990B	MY51000506	Jul. 10, 2022
2	Wideband power sensor	Keysight	N1923A	MY58310004	Jul. 10, 2022
3	Attenuator	WOKEN	6SM3502	VAS1214NL	N/A
4	RF Cable	Tongkaichuan	N/A	N/A	N/A

Frequency Stability					
Item	Kind of Equipment	Manufacturer	Type No.	Serial No.	Calibrated until
1	Spectrum Analyzer	R&S	FSP40	100185	Jul. 10, 2022
2	Precision Oven Tester	CEPREI	CEEC-M64T-40	15-008	Jan. 22, 2022 Jan. 22, 2023
3	Attenuator	WOKEN	6SM3502	VAS1214NL	N/A
4	RF Cable	Tongkaichuan	N/A	N/A	N/A
5	DC Block	Mini	N/A	N/A	N/A

Remark: "N/A" denotes no model name, serial no. or calibration specified.

"\*" calibration period of equipment list is three year.

Except \* item, all calibration period of equipment list is one year.

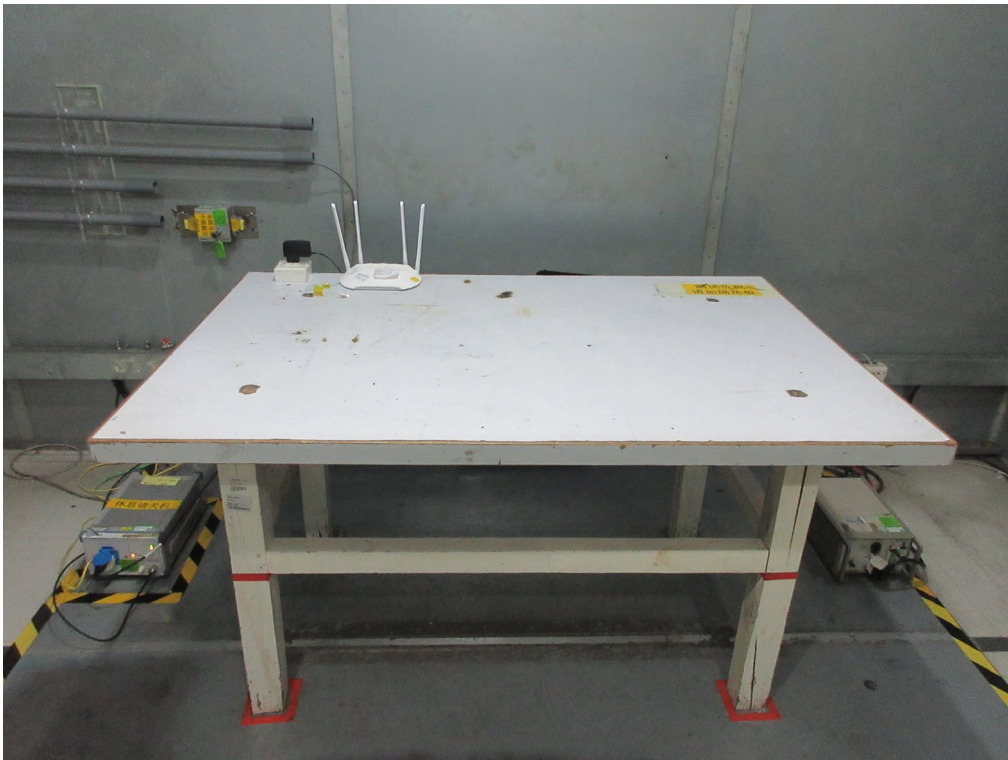

**10. EUT TEST PHOTOS****AC Power Line Conducted Emissions Test Photos**

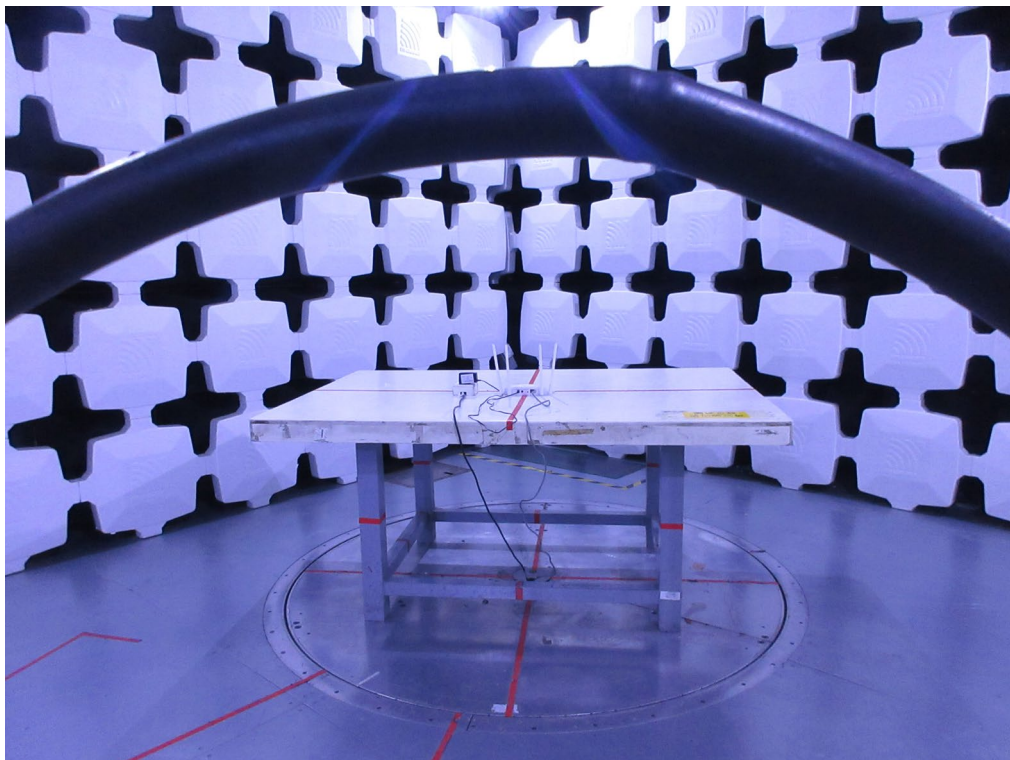
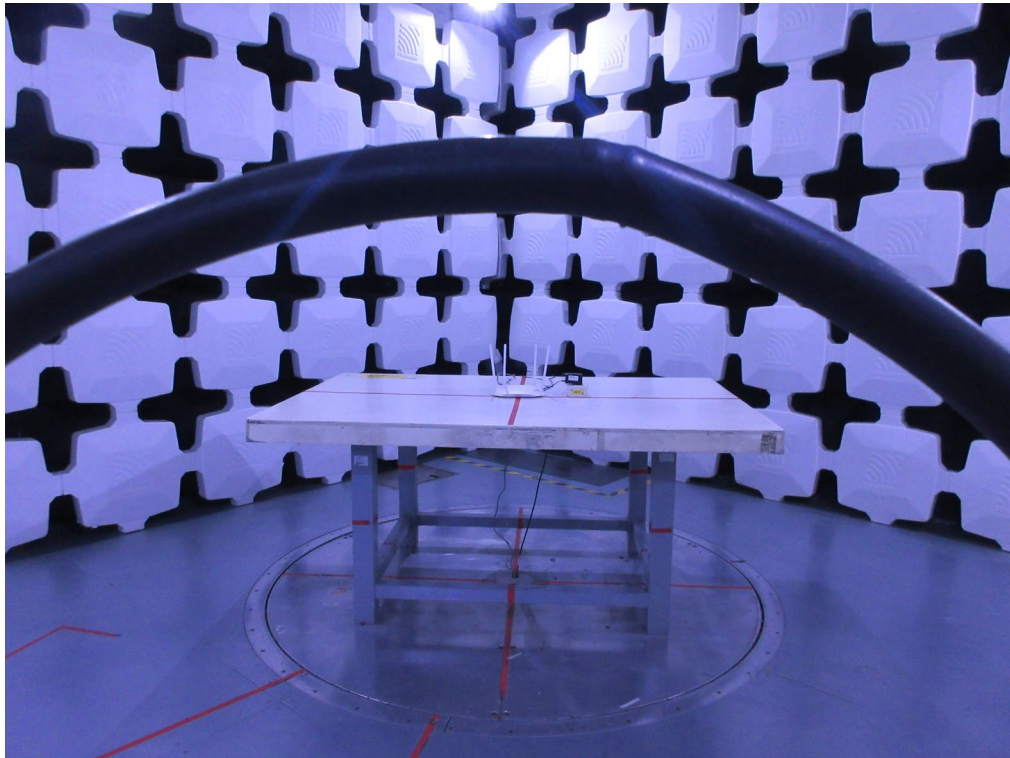
**Radiated Emissions Test Photos****9 kHz to 30 MHz**

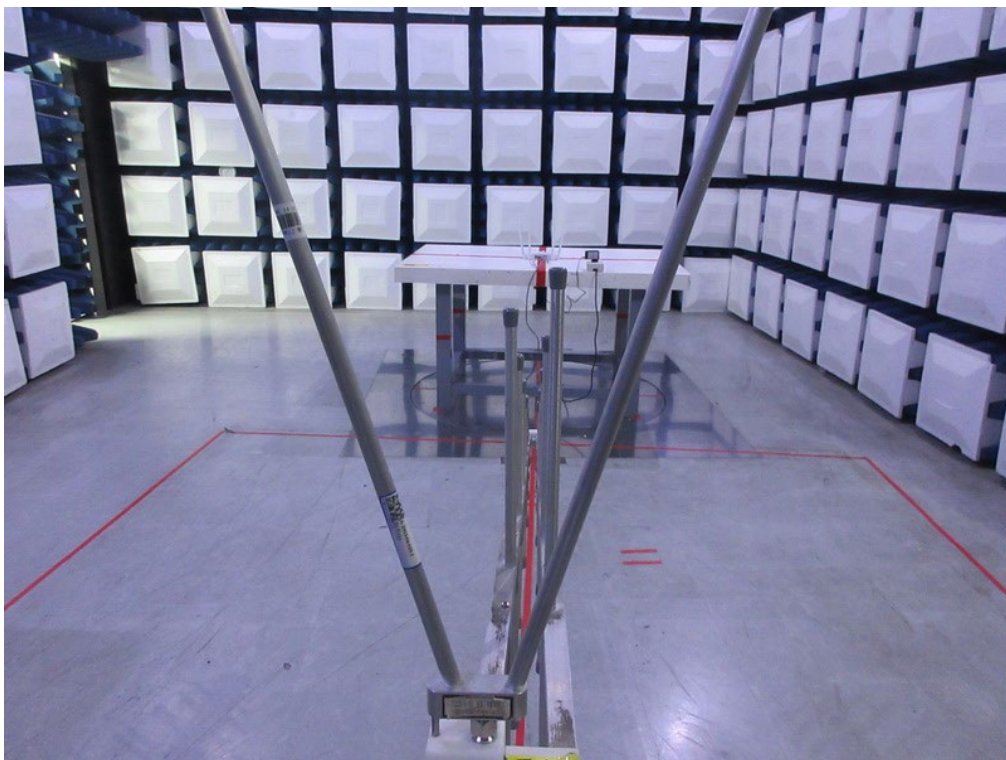
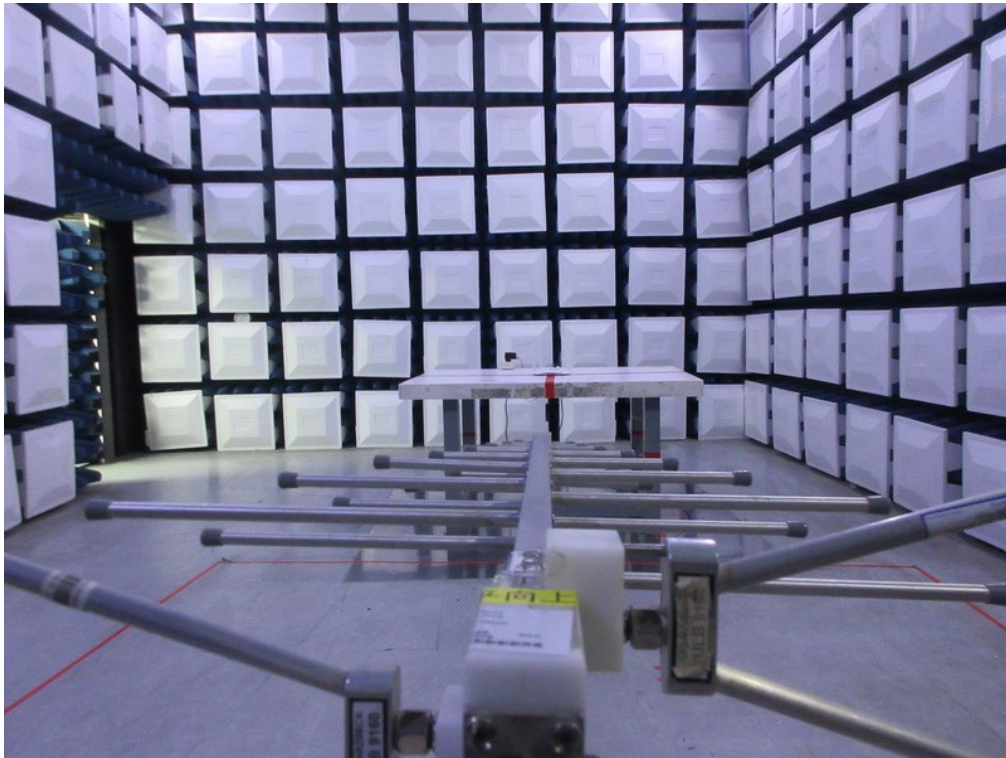
**Radiated Emissions Test Photos****30 MHz to 1 GHz**

**Radiated Emissions Test Photos****Above 1 GHz**

**Conducted Test Photos**

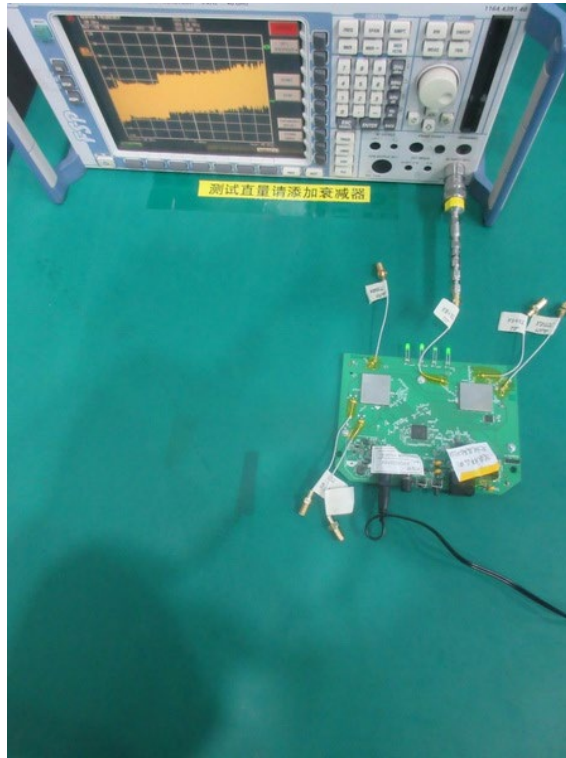

## **APPENDIX A - AC POWER LINE CONDUCTED EMISSIONS**

Test Mode	TX AC(VHT20) Mode Channel 48 (UNII-1)	Phase	Line
-----------	---------------------------------------	-------	------

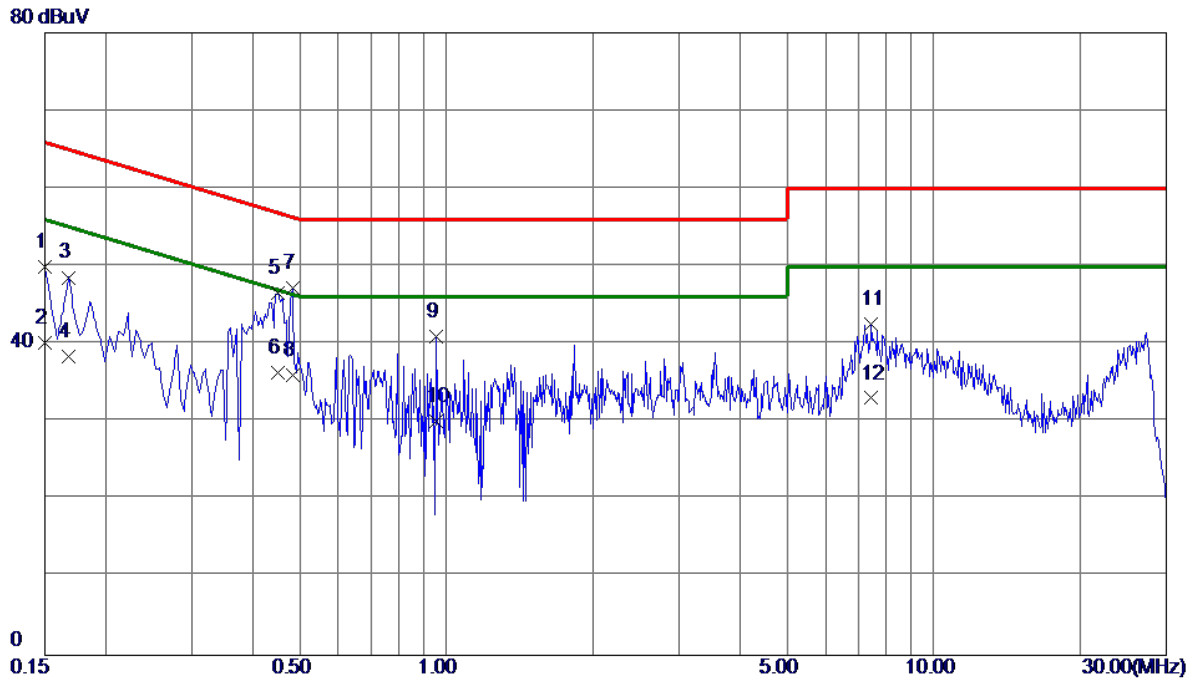

No.	Freq. MHz	Reading Level dBuV	Correct Factor dB	Measure ment dBuV	Limit dBuV	Margin dB	Detector	Comment
1	0.1500	40.06	9.78	49.84	66.00	-16.16	QP	
2	0.1500	30.40	9.78	40.18	56.00	-15.82	AVG	
3	0.1680	38.77	9.79	48.56	65.06	-16.50	QP	
4	0.1680	28.60	9.79	38.39	55.06	-16.67	AVG	
5	0.4515	36.68	9.86	46.54	56.85	-10.31	QP	
6	0.4515	26.40	9.86	36.26	46.85	-10.59	AVG	
7 *	0.4830	37.33	9.86	47.19	56.29	-9.10	QP	
8	0.4830	26.10	9.86	35.96	46.29	-10.33	AVG	
9	0.9510	30.95	10.01	40.96	56.00	-15.04	QP	
10	0.9510	20.10	10.01	30.11	46.00	-15.89	AVG	
11	7.4535	32.15	10.44	42.59	60.00	-17.41	QP	
12	7.4535	22.60	10.44	33.04	50.00	-16.96	AVG	

**REMARKS:**

- (1) Measurement Value = Reading Level + Correct Factor.
- (2) Margin Level = Measurement Value - Limit Value.
- (3) The test result has included the cable loss.

Test Mode	TX AC(VHT20) Mode Channel 48 (UNII-1)	Phase	Neutral
-----------	---------------------------------------	-------	---------

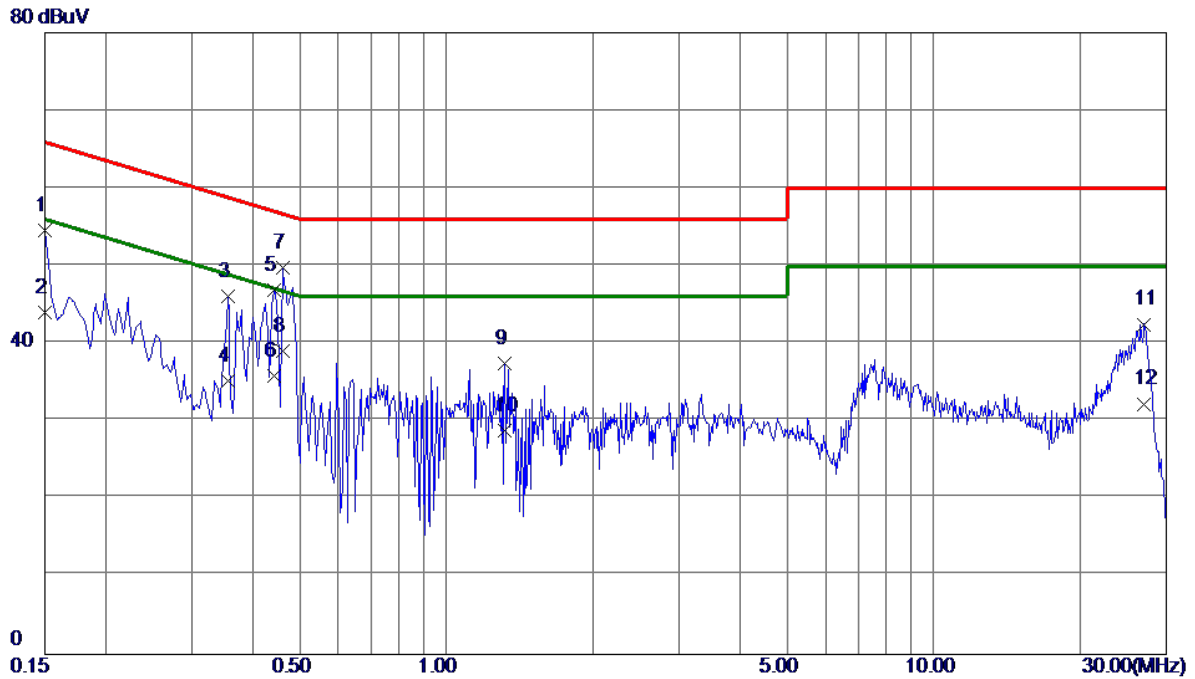

No.	Freq. MHz	Reading Level dBuV	Correct Factor dB	Measure ment dBuV	Limit dBuV	Margin dB	Detector	Comment
1	0.1500	44.76	9.82	54.58	66.00	-11.42	QP	
2	0.1500	34.20	9.82	44.02	56.00	-11.98	AVG	
3	0.3570	36.15	9.91	46.06	58.80	-12.74	QP	
4	0.3570	25.30	9.91	35.21	48.80	-13.59	AVG	
5	0.4425	36.98	9.93	46.91	57.01	-10.10	QP	
6	0.4425	25.99	9.93	35.92	47.01	-11.09	AVG	
7 *	0.4605	39.88	9.93	49.81	56.68	-6.87	QP	
8	0.4605	29.11	9.93	39.04	46.68	-7.64	AVG	
9	1.3200	27.26	10.19	37.45	56.00	-18.55	QP	
10	1.3200	18.60	10.19	28.79	46.00	-17.21	AVG	
11	27.0330	31.24	11.24	42.48	60.00	-17.52	QP	
12	27.0330	21.00	11.24	32.24	50.00	-17.76	AVG	

**REMARKS:**

- (1) Measurement Value = Reading Level + Correct Factor.
- (2) Margin Level = Measurement Value - Limit Value.
- (3) The test result has included the cable loss.



**APPENDIX B - RADIATED EMISSION - 9 KHZ TO 30 MHZ**

Test Mode	TX AC(VHT20) Mode Channel 48 (UNII-1)	Polarization	Ant 0°
-----------	---------------------------------------	--------------	--------

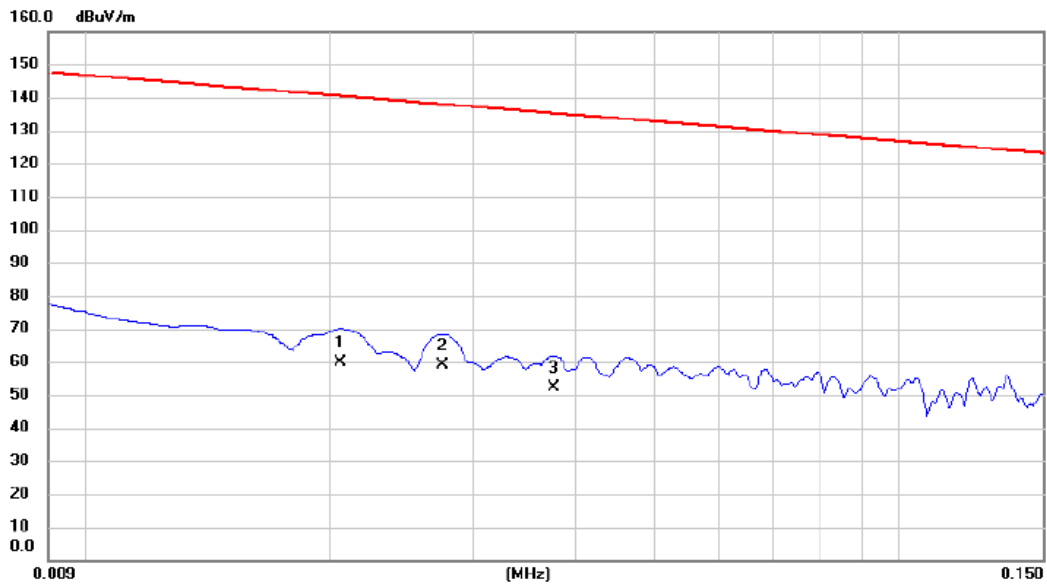

No.	Mk.	Freq. MHz	Reading Level dBuV	Correct Factor dB	Measure- ment dBuV/m	Limit dBuV/m	Margin dB	Detector	Antenna Height cm	Table Degree	Comment
1		0.0206	45.63	14.28	59.91	140.41	-80.50	AVG			
2	*	0.0275	44.85	14.12	58.97	137.90	-78.93	AVG			
3		0.0376	38.24	13.89	52.13	135.18	-83.05	AVG			

**REMARKS:**

(1) Measurement Value = Reading Level + Correct Factor.

(2) Margin Level = Measurement Value - Limit Value.

Test Mode	TX AC(VHT20) Mode Channel 48 (UNII-1)	Polarization	Ant 0°
-----------	---------------------------------------	--------------	--------

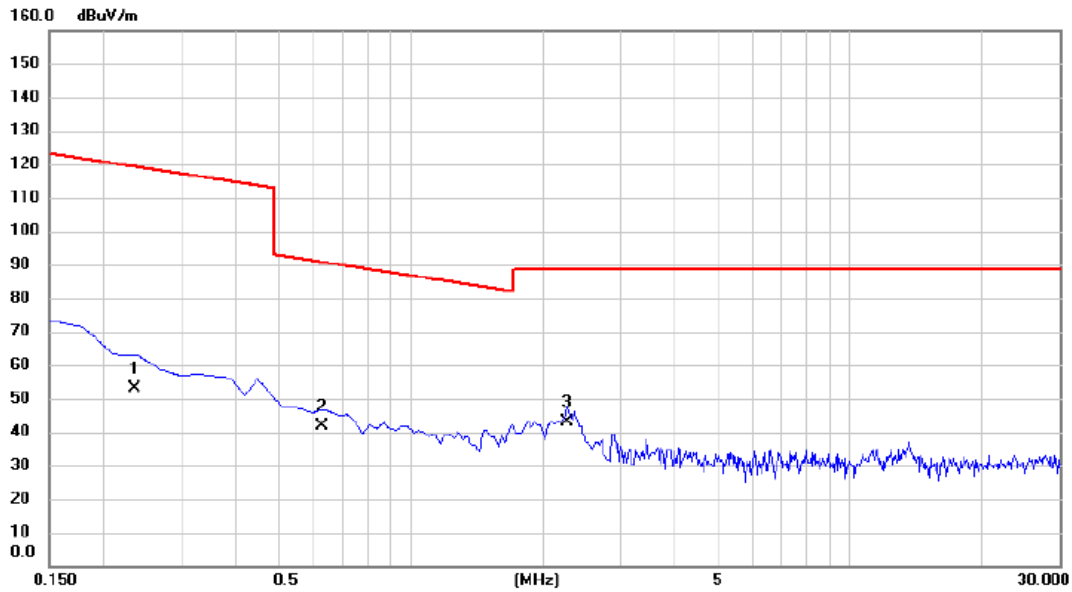

No.	Mk.	Freq.	Reading Level	Correct Factor	Measurement	Limit	Margin	Antenna Height	Table Degree	
		MHz	dBuV	dB	dBuV/m	dBuV/m	dB	cm	degree	Comment
1		0.2341	39.25	13.62	52.87	119.30	-66.43			AVG
2		0.6276	28.63	13.21	41.84	90.74	-48.90			QP
3	*	2.2694	30.88	11.98	42.86	88.63	-45.77			QP

REMARKS:

- (1) Measurement Value = Reading Level + Correct Factor.
- (2) Margin Level = Measurement Value - Limit Value.

Test Mode	TX AC(VHT20) Mode Channel 48 (UNII-1)	Polarization	Ant 90°
-----------	---------------------------------------	--------------	---------

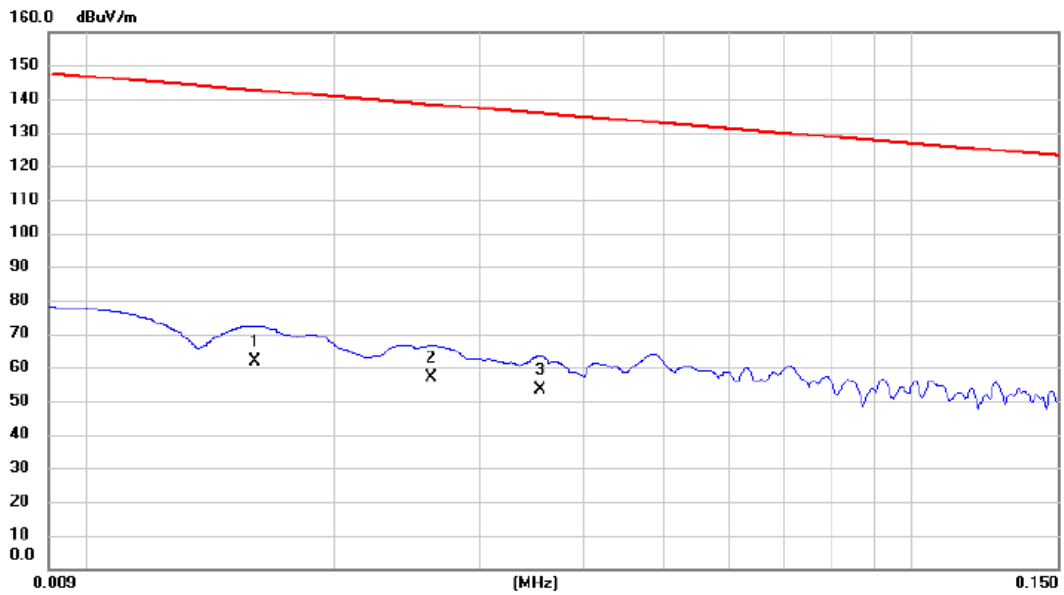

No.	Mk.	Freq. MHz	Reading Level dBuV	Correct Factor dB	Measure- ment dBuV/m	Limit dBuV/m	Margin dB	Detector	Antenna Height cm	Table Degree	Comment
1	*	0.0160	46.35	15.55	61.90	142.60	-80.70	AVG			
2		0.0262	42.88	14.15	57.03	138.32	-81.29	AVG			
3		0.0354	39.62	13.94	53.56	135.70	-82.14	AVG			

**REMARKS:**

- (1) Measurement Value = Reading Level + Correct Factor.
- (2) Margin Level = Measurement Value - Limit Value.

Test Mode	TX AC(VHT20) Mode Channel 48 (UNII-1)	Polarization	Ant 90°
-----------	---------------------------------------	--------------	---------

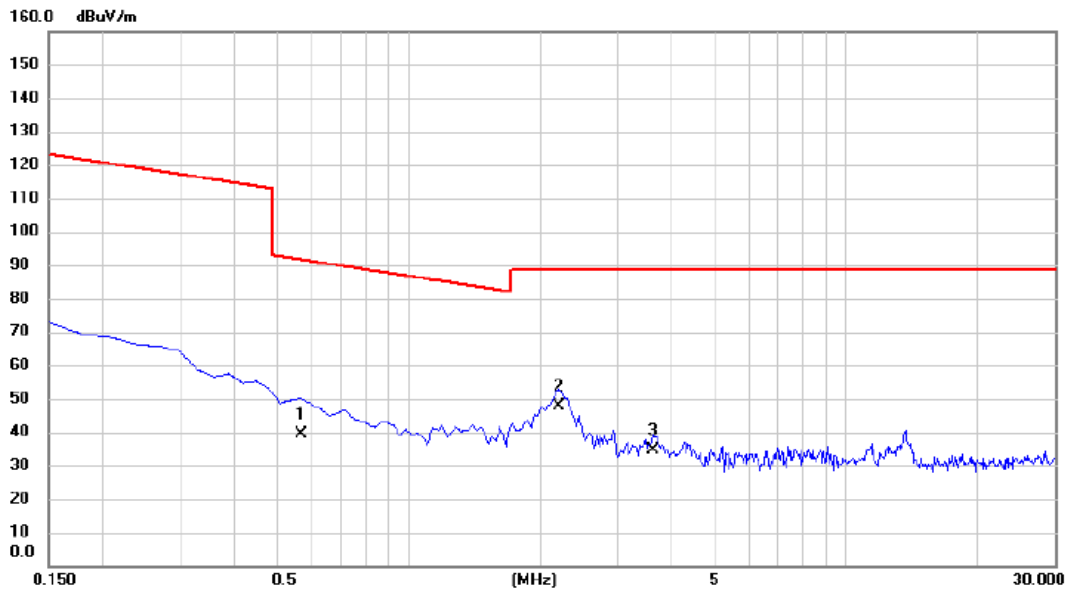

No. Mk.	Freq. MHz	Reading Level dBuV	Correct Factor dB	Measure- ment dBuV/m	Limit dBuV/m	Margin dB	Detector	Antenna Height cm	Table Degree degree	Comment
1	0.5680	26.12	13.28	39.40	91.61	-52.21	AVG			
2 *	2.2096	35.85	12.01	47.86	88.63	-40.77	QP			
3	3.6126	22.96	11.72	34.68	88.63	-53.95	QP			

**REMARKS:**

- (1) Measurement Value = Reading Level + Correct Factor.
- (2) Margin Level = Measurement Value - Limit Value.

**APPENDIX C - RADIATED EMISSION - 30 MHZ TO 1000 MHZ**

Test Mode	TX AC(VHT20) Mode Channel 48 (UNII-1)	Polarization	Vertical
-----------	---------------------------------------	--------------	----------

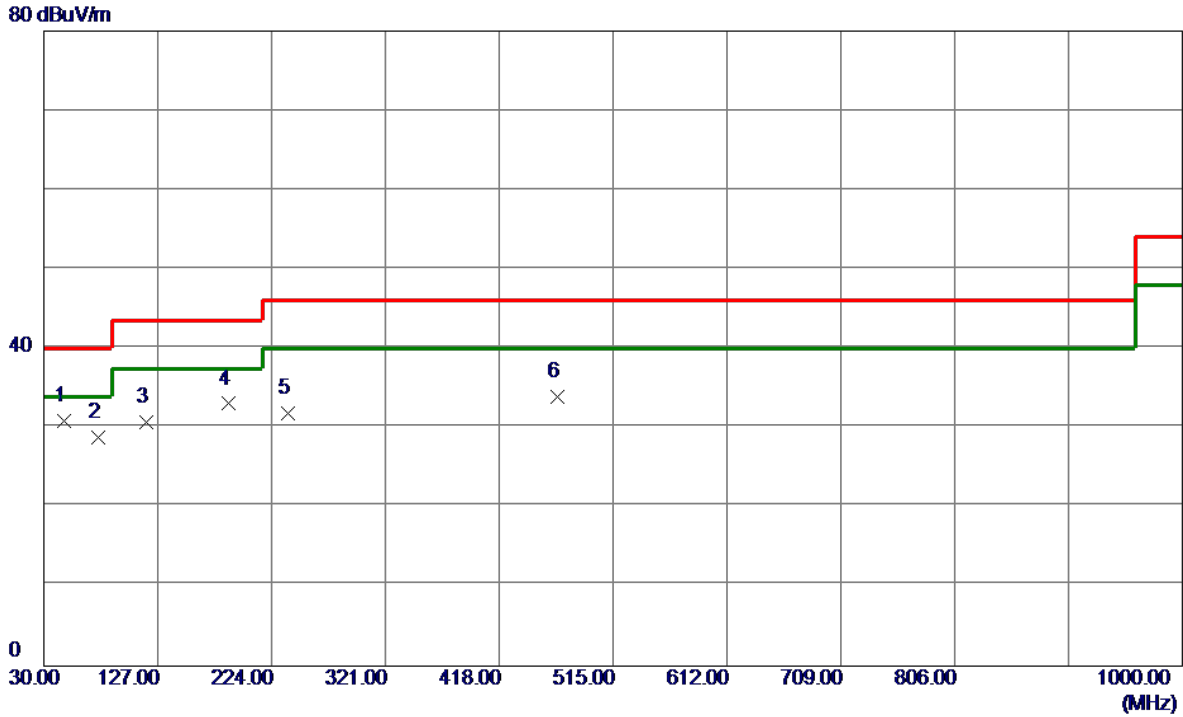

No.	Freq. MHz	Reading Level dBuV/m	Correct Factor dB	Measure ment dBuV/m	Limit dBuV/m	Margin dB	Detector	Comment
1 *	47.4600	44.77	-13.83	30.94	40.00	-9.06	Peak	
2	76.5600	46.49	-17.67	28.82	40.00	-11.18	Peak	
3	117.3000	45.15	-14.45	30.70	43.50	-12.80	Peak	
4	187.1400	47.68	-14.64	33.04	43.50	-10.46	Peak	
5	237.5800	45.46	-13.61	31.85	46.00	-14.15	Peak	
6	467.4700	41.23	-7.32	33.91	46.00	-12.09	Peak	

**REMARKS:**

- (1) Measurement Value = Reading Level + Correct Factor.
- (2) Margin Level = Measurement Value - Limit Value.

Test Mode	TX AC(VHT20) Mode Channel 48 (UNII-1)	Polarization	Horizontal
-----------	---------------------------------------	--------------	------------

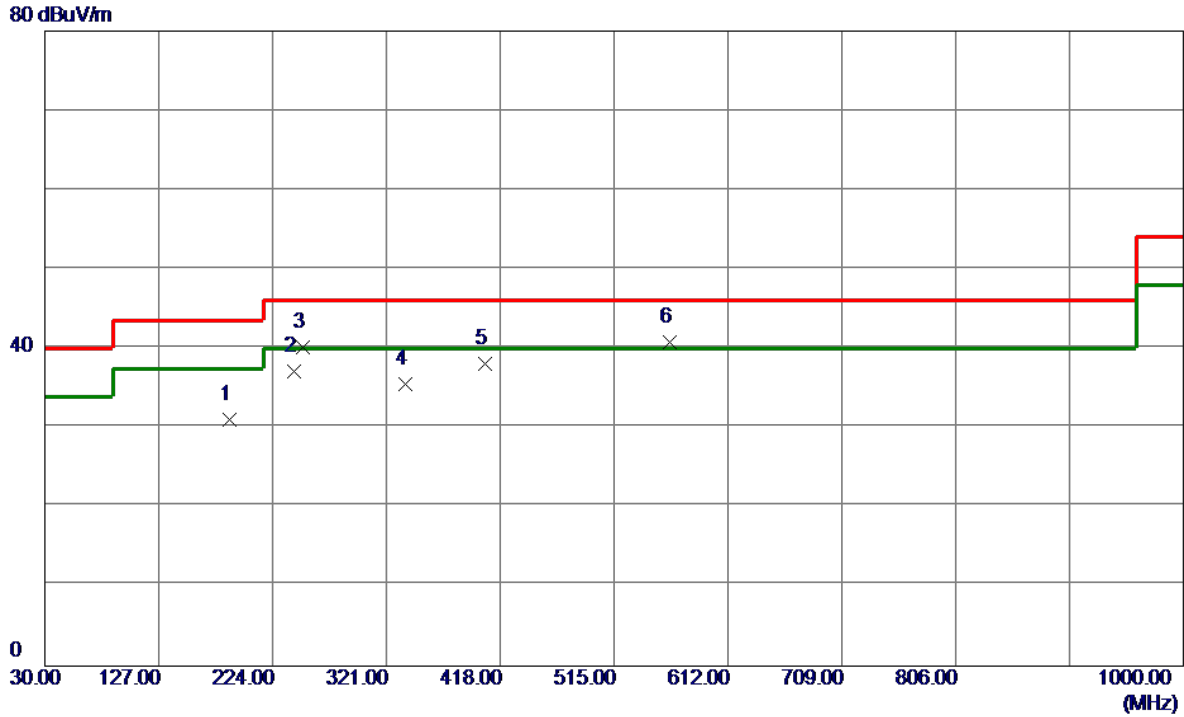

No.	Freq. MHz	Reading Level dBuV/m	Correct Factor dB	Measure ment dBuV/m	Limit dBuV/m	Margin dB	Detector	Comment
1	187.1400	45.72	-14.64	31.08	43.50	-12.42	Peak	
2	242.4300	50.43	-13.37	37.06	46.00	-8.94	Peak	
3	250.1900	53.15	-13.02	40.13	46.00	-5.87	Peak	
4	337.4900	45.89	-10.33	35.56	46.00	-10.44	Peak	
5	405.3900	46.84	-8.81	38.03	46.00	-7.97	Peak	
6 *	562.5300	46.68	-5.84	40.84	46.00	-5.16	Peak	

**REMARKS:**

- (1) Measurement Value = Reading Level + Correct Factor.
- (2) Margin Level = Measurement Value - Limit Value.



**APPENDIX D - RADIATED EMISSION - ABOVE 1000 MHZ**

Test Mode	UNII-1_TX A Mode 5180 MHz	Polarization	Vertical
-----------	---------------------------	--------------	----------

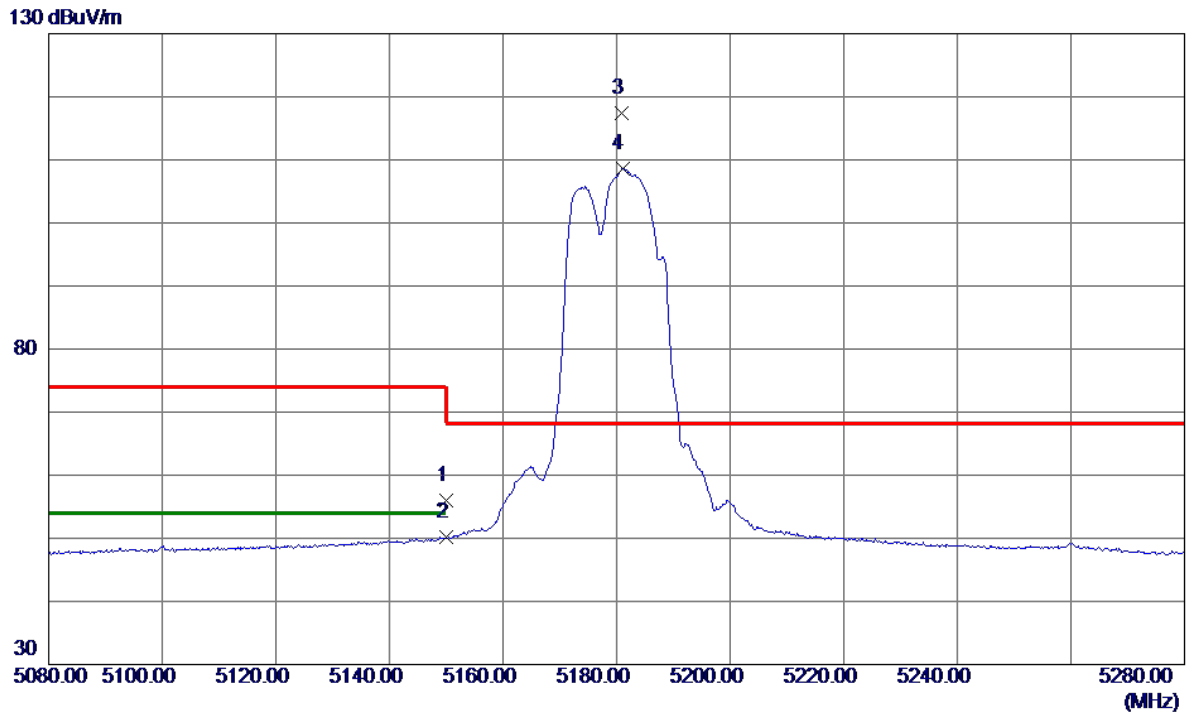

No.	Freq. MHz	Reading Level dBuV/m	Correct Factor dB	Measure ment dBuV/m	Limit dBuV/m	Margin dB	Detector	Comment
1	5150.0000	38.03	17.90	55.93	74.00	-18.07	Peak	
2	5150.0000	32.28	17.90	50.18	54.00	-3.82	AVG	
3 *	5180.9000	99.45	18.02	117.47	68.20	49.27	Peak	No Limit
4	5181.0000	90.57	18.02	108.59	999.00	-890.41	AVG	No Limit

**REMARKS:**

- (1) Measurement Value = Reading Level + Correct Factor.
- (2) Margin Level = Measurement Value - Limit Value.

Test Mode	UNII-1_TX A Mode 5180 MHz	Polarization	Vertical
-----------	---------------------------	--------------	----------

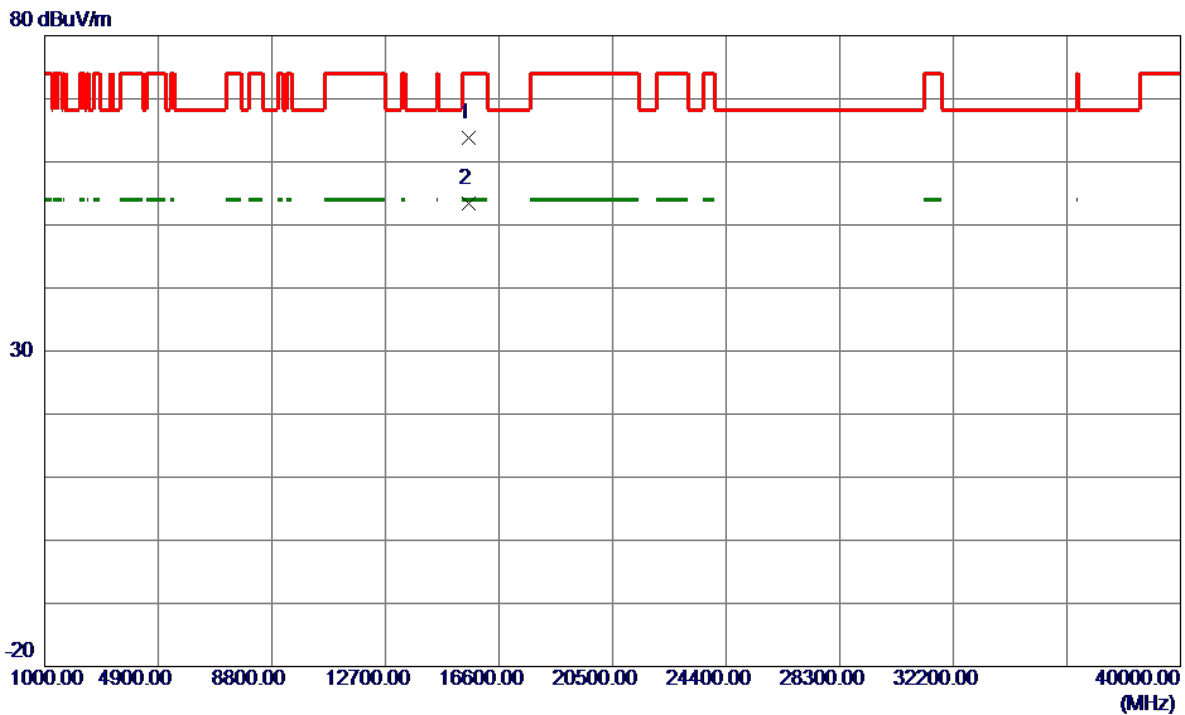

No.	Freq. MHz	Reading Level dBuV/m	Correct Factor dB	Measure ment dBuV/m	Limit dBuV/m	Margin dB	Detector	Comment
1	15540.3400	47.68	16.03	63.71	74.00	-10.29	Peak	
2 *	15540.5200	37.28	16.03	53.31	54.00	-0.69	AVG	

**REMARKS:**

- (1) Measurement Value = Reading Level + Correct Factor.
- (2) Margin Level = Measurement Value - Limit Value.

Test Mode	UNII-1_TX A Mode 5180 MHz	Polarization	Horizontal
-----------	---------------------------	--------------	------------

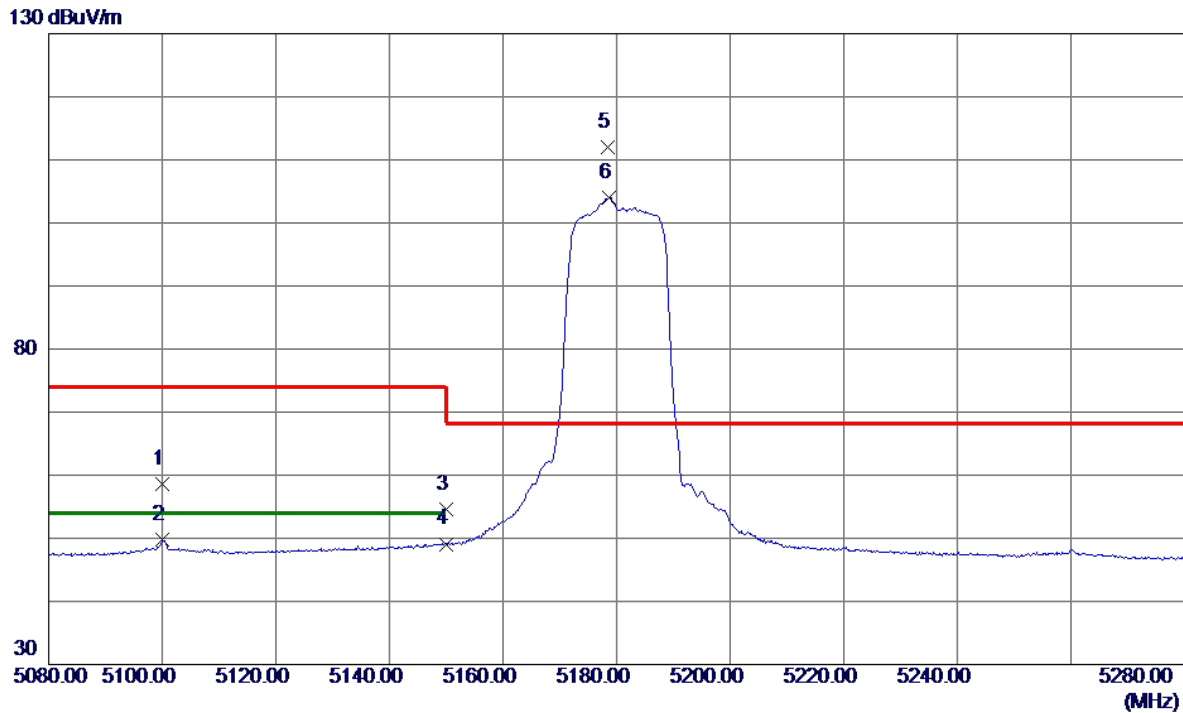

No.	Freq. MHz	Reading Level dBuV/m	Correct Factor dB	Measure ment dBuV/m	Limit dBuV/m	Margin dB	Detector	Comment
1	5100.1000	40.83	17.71	58.54	74.00	-15.46	Peak	
2	5100.1000	32.03	17.71	49.74	54.00	-4.26	AVG	
3	5150.0000	36.64	17.90	54.54	74.00	-19.46	Peak	
4	5150.0000	31.20	17.90	49.10	54.00	-4.90	AVG	
5 *	5178.5000	94.01	18.01	112.02	68.20	43.82	Peak	No Limit
6	5178.6000	86.01	18.01	104.02	999.00	-894.98	AVG	No Limit

**REMARKS:**

- (1) Measurement Value = Reading Level + Correct Factor.
- (2) Margin Level = Measurement Value - Limit Value.

Test Mode	UNII-1_TX A Mode 5180 MHz	Polarization	Horizontal
-----------	---------------------------	--------------	------------

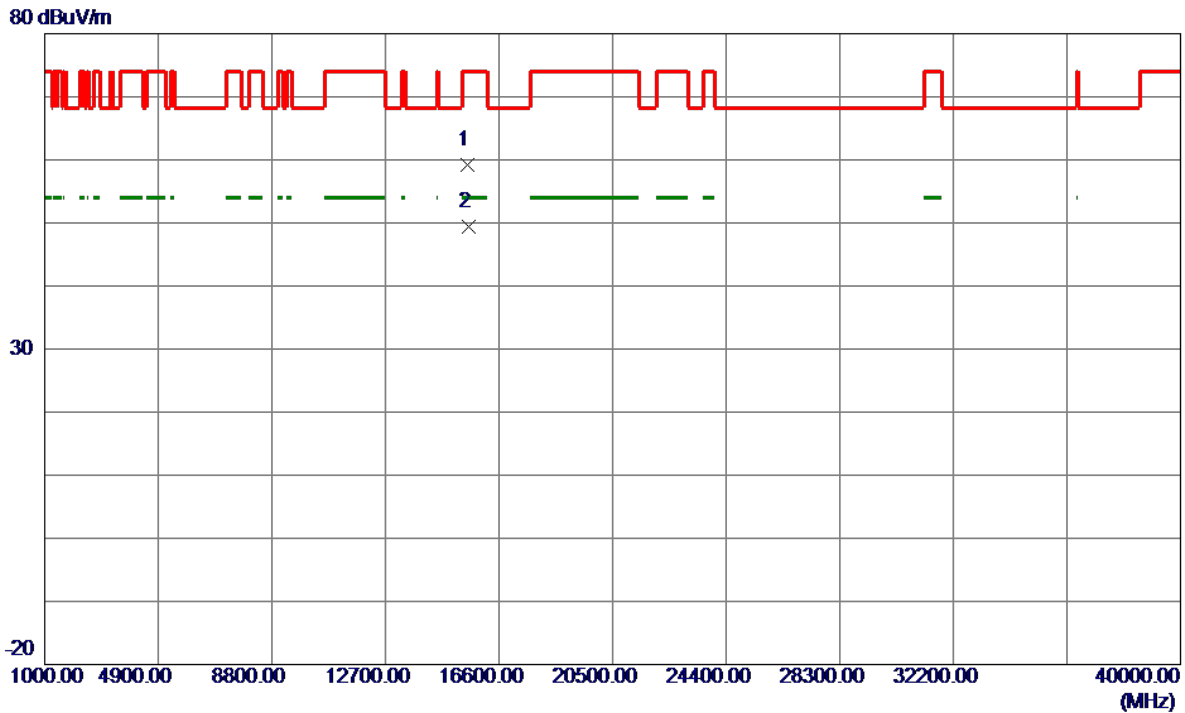

No.	Freq. MHz	Reading Level dBuV/m	Correct Factor dB	Measure ment dBuV/m	Limit dBuV/m	Margin dB	Detector	Comment
1	15537.5500	43.19	16.03	59.22	74.00	-14.78	Peak	
2 *	15543.4000	33.43	16.03	49.46	54.00	-4.54	AVG	

**REMARKS:**

- (1) Measurement Value = Reading Level + Correct Factor.
- (2) Margin Level = Measurement Value - Limit Value.

Test Mode	UNII-1_TX A Mode 5200 MHz	Polarization	Vertical
-----------	---------------------------	--------------	----------

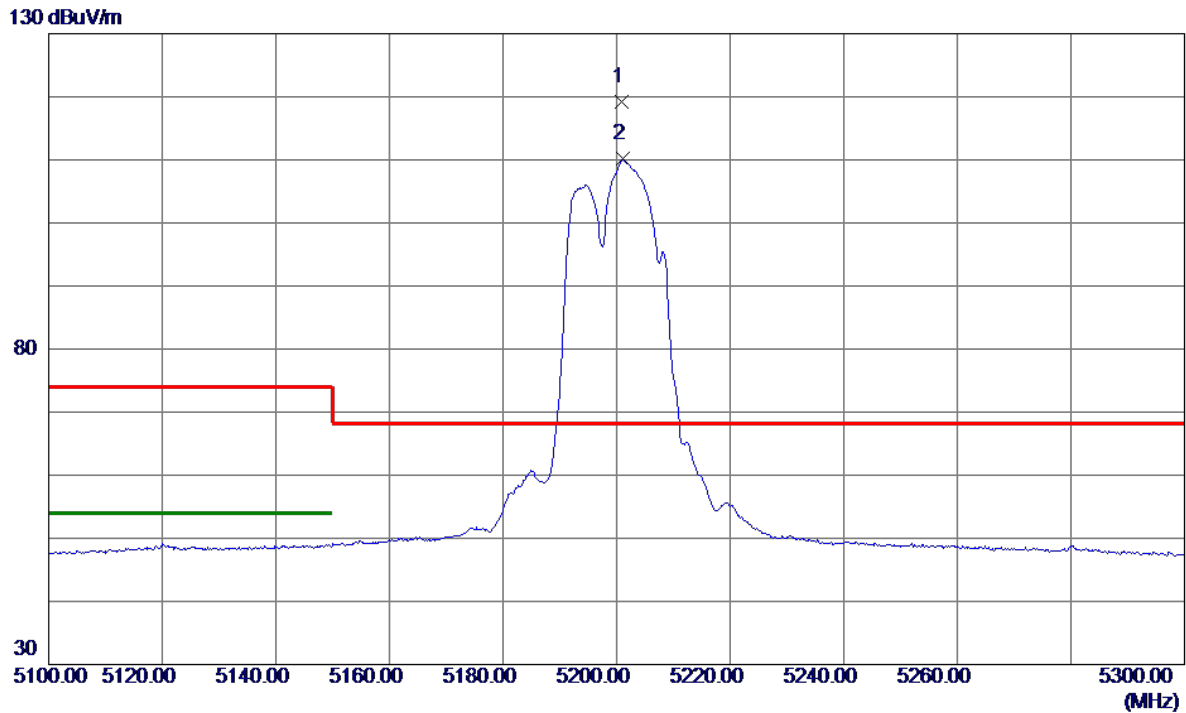

No.	Freq. MHz	Reading Level dBuV/m	Correct Factor dB	Measure ment dBuV/m	Limit dBuV/m	Margin dB	Detector	Comment
1 *	5200.9000	101.16	18.10	119.26	68.20	51.06	Peak	No Limit
2	5201.1000	92.01	18.10	110.11	999.00	-888.89	AVG	No Limit

REMARKS:

- (1) Measurement Value = Reading Level + Correct Factor.
- (2) Margin Level = Measurement Value - Limit Value.

Test Mode	UNII-1_TX A Mode 5200 MHz	Polarization	Vertical
-----------	---------------------------	--------------	----------



No.	Freq. MHz	Reading Level dBuV/m	Correct Factor dB	Measure ment dBuV/m	Limit dBuV/m	Margin dB	Detector	Comment
1 *	15603.7200	37.18	16.04	53.22	54.00	-0.78	AVG	
2	15603.9000	50.38	16.04	66.42	74.00	-7.58	Peak	

**REMARKS:**

- (1) Measurement Value = Reading Level + Correct Factor.
- (2) Margin Level = Measurement Value - Limit Value.

Test Mode	UNII-1_TX A Mode 5200 MHz	Polarization	Horizontal
-----------	---------------------------	--------------	------------

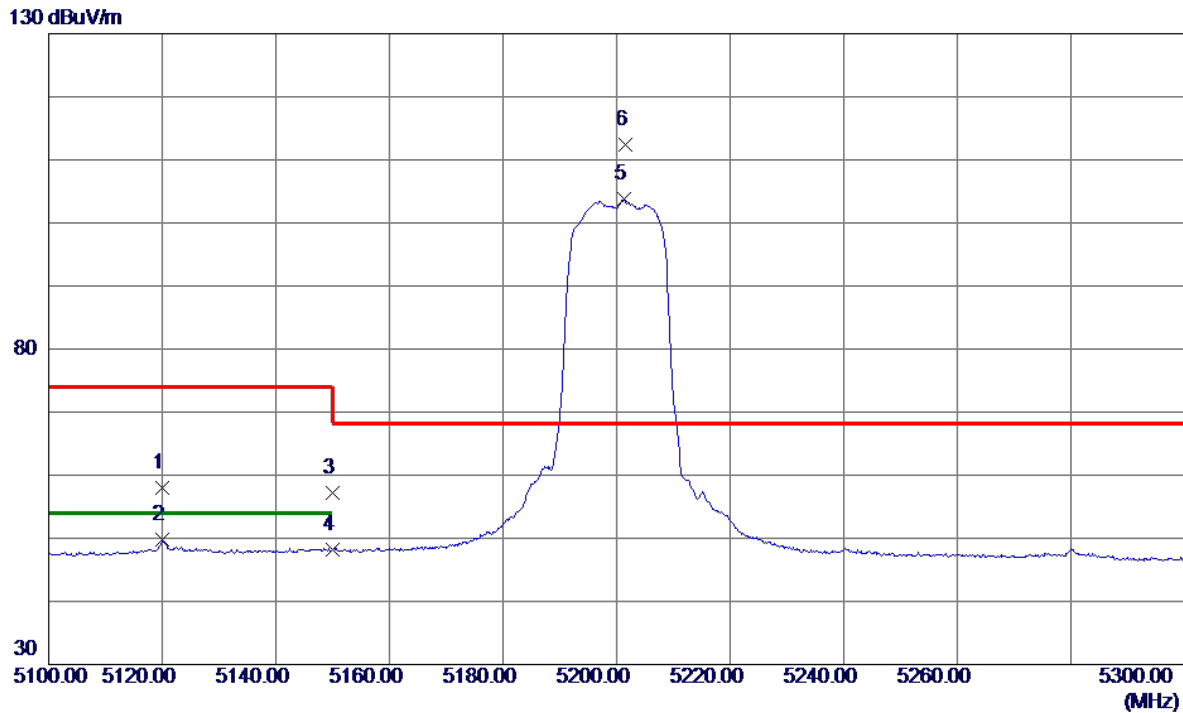

No.	Freq. MHz	Reading Level dBuV/m	Correct Factor dB	Measure ment dBuV/m	Limit dBuV/m	Margin dB	Detector	Comment
1	5120.1000	40.24	17.79	58.03	74.00	-15.97	Peak	
2	5120.1000	32.07	17.79	49.86	54.00	-4.14	AVG	
3	5150.0000	39.23	17.90	57.13	74.00	-16.87	Peak	
4	5150.0000	30.29	17.90	48.19	54.00	-5.81	AVG	
5	5201.4000	85.62	18.10	103.72	999.00	-895.28	AVG	No Limit
6 *	5201.5000	94.21	18.10	112.31	68.20	44.11	Peak	No Limit

**REMARKS:**

- (1) Measurement Value = Reading Level + Correct Factor.
- (2) Margin Level = Measurement Value - Limit Value.



Test Mode	UNII-1_TX A Mode 5200 MHz	Polarization	Horizontal
-----------	---------------------------	--------------	------------

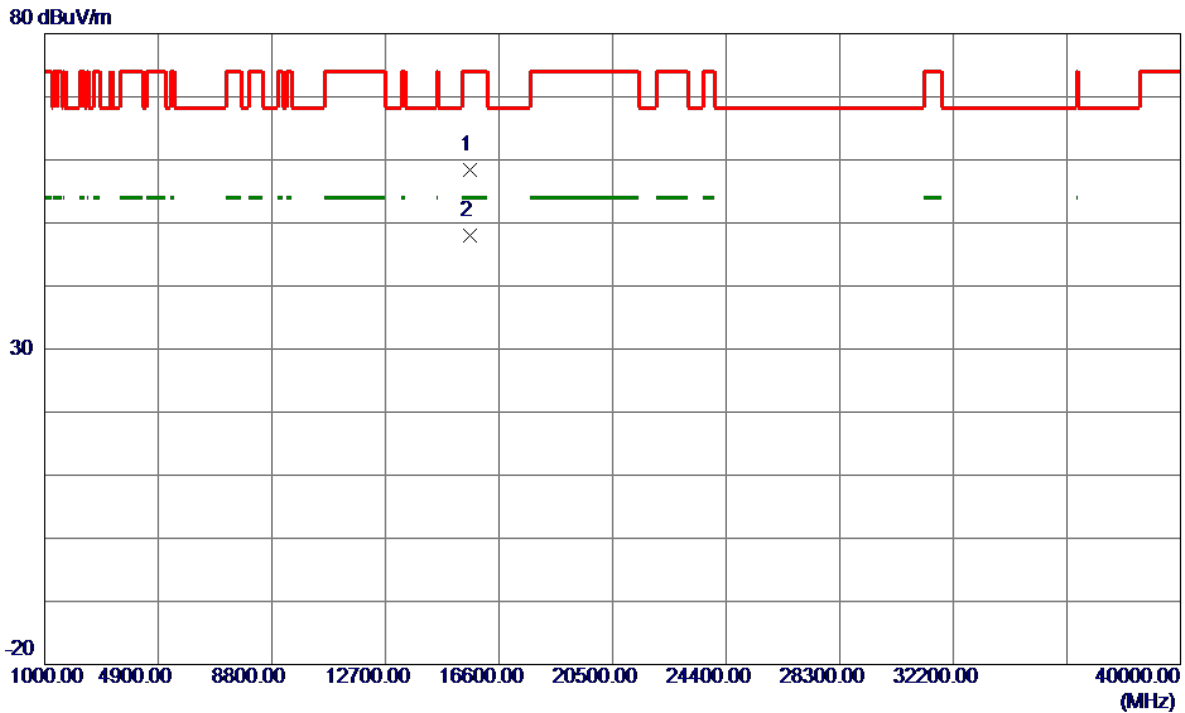

No.	Freq. MHz	Reading Level dBuV/m	Correct Factor dB	Measure ment dBuV/m	Limit dBuV/m	Margin dB	Detector	Comment
1	15602.8000	42.40	16.04	58.44	74.00	-15.56	Peak	
2 *	15603.3500	31.98	16.04	48.02	54.00	-5.98	AVG	

REMARKS:

- (1) Measurement Value = Reading Level + Correct Factor.
- (2) Margin Level = Measurement Value - Limit Value.

Test Mode	UNII-1_TX A Mode 5240 MHz	Polarization	Vertical
-----------	---------------------------	--------------	----------

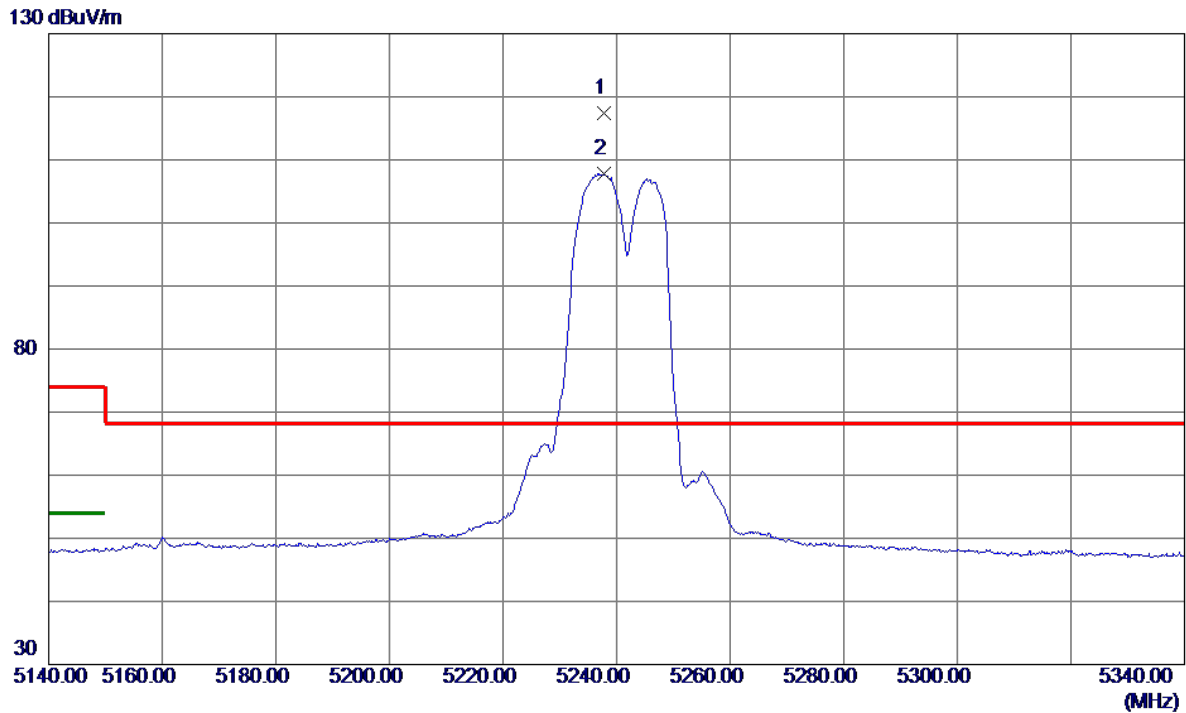

No.	Freq. MHz	Reading Level dBuV/m	Correct Factor dB	Measure ment dBuV/m	Limit dBuV/m	Margin dB	Detector	Comment
1 *	5237.7000	99.18	18.24	117.42	68.20	49.22	Peak	No Limit
2	5237.8000	89.59	18.24	107.83	999.00	-891.17	AVG	No Limit

**REMARKS:**

- (1) Measurement Value = Reading Level + Correct Factor.
- (2) Margin Level = Measurement Value - Limit Value.

Test Mode	UNII-1_TX A Mode 5240 MHz	Polarization	Vertical
-----------	---------------------------	--------------	----------



No.	Freq. MHz	Reading Level dBuV/m	Correct Factor dB	Measure ment dBuV/m	Limit dBuV/m	Margin dB	Detector	Comment
1 *	15720.9600	37.66	16.06	53.72	54.00	-0.28	AVG	
2	15721.5400	48.40	16.06	64.46	74.00	-9.54	Peak	

**REMARKS:**

- (1) Measurement Value = Reading Level + Correct Factor.
- (2) Margin Level = Measurement Value - Limit Value.

Test Mode	UNII-1_TX A Mode 5240 MHz	Polarization	Horizontal
-----------	---------------------------	--------------	------------

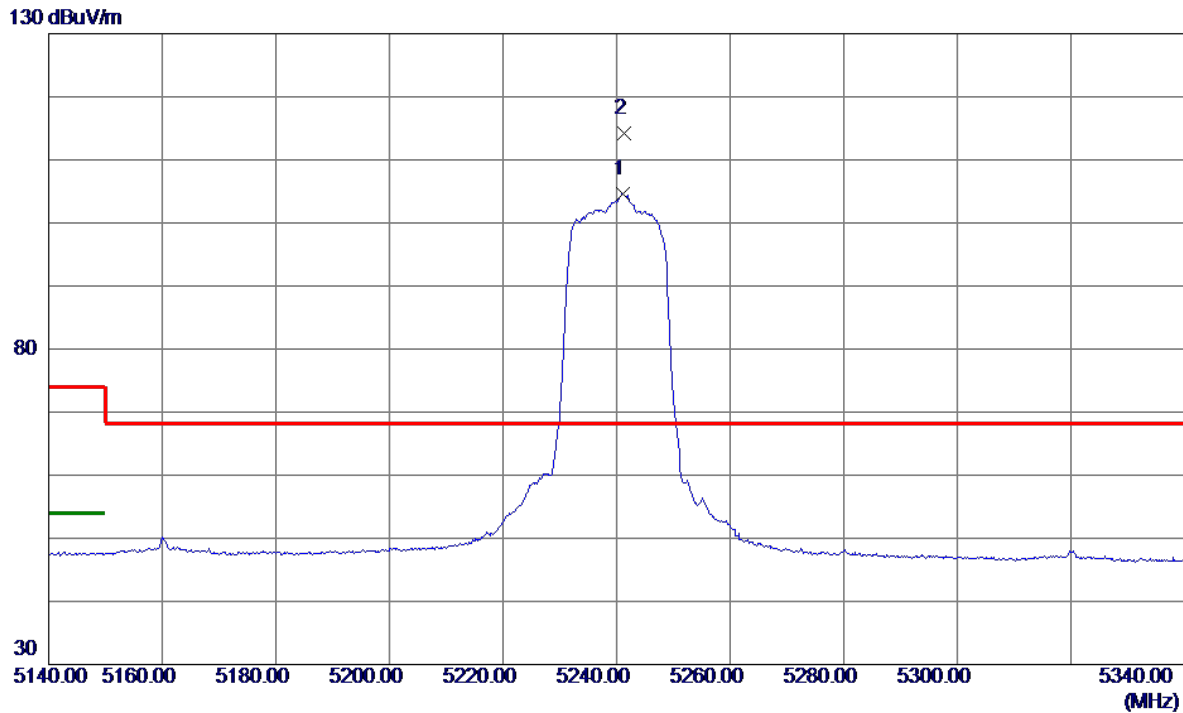

No.	Freq. MHz	Reading Level dBuV/m	Correct Factor dB	Measure ment dBuV/m	Limit dBuV/m	Margin dB	Detector	Comment
1	5241.1000	86.37	18.25	104.62	999.00	-894.38	AVG	No Limit
2 *	5241.3000	95.86	18.26	114.12	68.20	45.92	Peak	No Limit

**REMARKS:**

- (1) Measurement Value = Reading Level + Correct Factor.
- (2) Margin Level = Measurement Value - Limit Value.

Test Mode	UNII-1_TX A Mode 5240 MHz	Polarization	Horizontal
-----------	---------------------------	--------------	------------

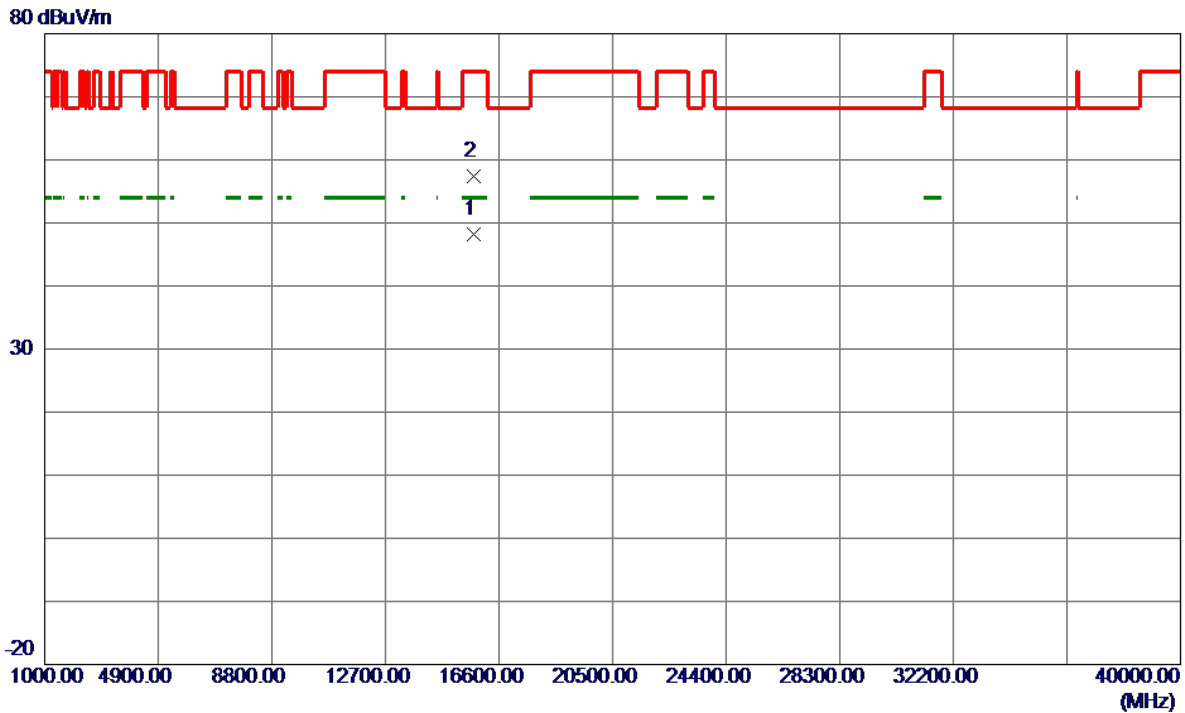

No.	Freq. MHz	Reading Level dBuV/m	Correct Factor dB	Measure ment dBuV/m	Limit dBuV/m	Margin dB	Detector	Comment
1 *	15720.2000	32.22	16.06	48.28	54.00	-5.72	AVG	
2	15720.3500	41.28	16.06	57.34	74.00	-16.66	Peak	

**REMARKS:**

- (1) Measurement Value = Reading Level + Correct Factor.
- (2) Margin Level = Measurement Value - Limit Value.

Test Mode	UNII-1_TX AC(VHT20) Mode 5180 MHz	Polarization	Vertical
-----------	-----------------------------------	--------------	----------

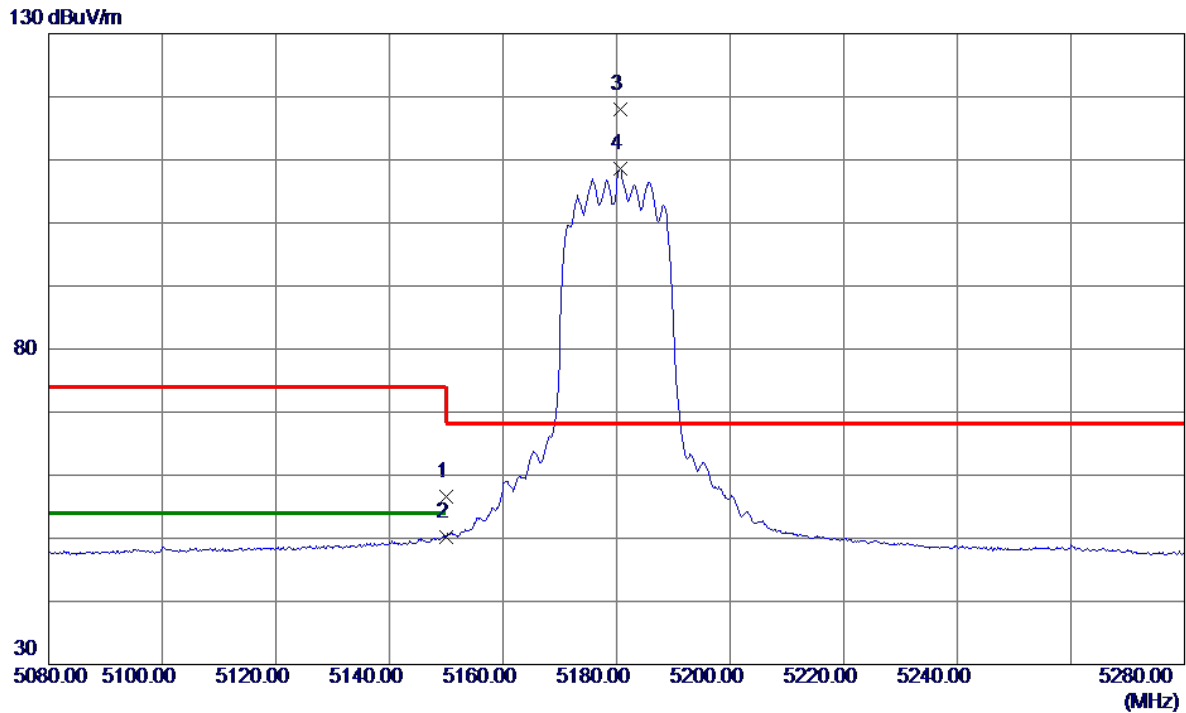

No.	Freq. MHz	Reading Level dBuV/m	Correct Factor dB	Measure ment dBuV/m	Limit dBuV/m	Margin dB	Detector	Comment
1	5150.0000	38.75	17.90	56.65	74.00	-17.35	Peak	
2	5150.0000	32.34	17.90	50.24	54.00	-3.76	AVG	
3 *	5180.6000	100.08	18.02	118.10	68.20	49.90	Peak	No Limit
4	5180.7000	90.56	18.02	108.58	999.00	-890.42	AVG	No Limit

**REMARKS:**

- (1) Measurement Value = Reading Level + Correct Factor.
- (2) Margin Level = Measurement Value - Limit Value.

Test Mode	UNII-1_TX AC(VHT20) Mode 5180 MHz	Polarization	Vertical
-----------	-----------------------------------	--------------	----------

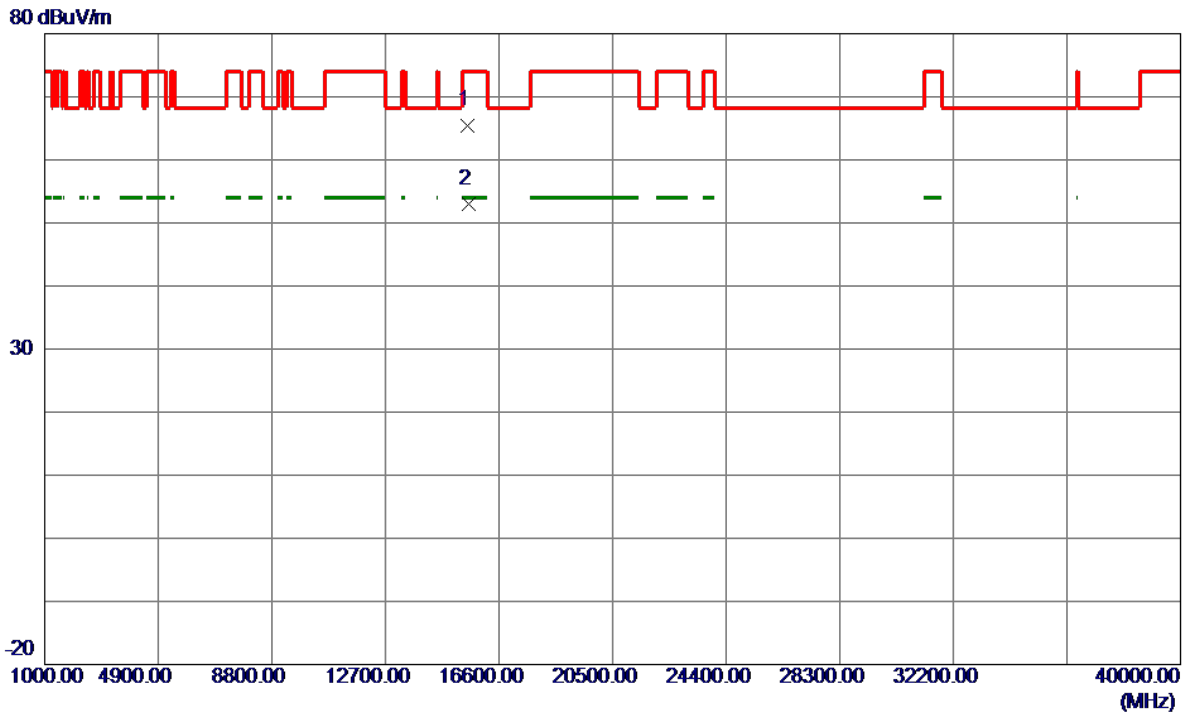

No.	Freq. MHz	Reading Level dBuV/m	Correct Factor dB	Measure ment dBuV/m	Limit dBuV/m	Margin dB	Detector	Comment
1	15536.6600	49.47	16.03	65.50	74.00	-8.50	Peak	
2 *	15539.6400	36.97	16.03	53.00	54.00	-1.00	AVG	

REMARKS:

- (1) Measurement Value = Reading Level + Correct Factor.
- (2) Margin Level = Measurement Value - Limit Value.

Test Mode	UNII-1_TX AC(VHT20) Mode 5180 MHz	Polarization	Horizontal
-----------	-----------------------------------	--------------	------------

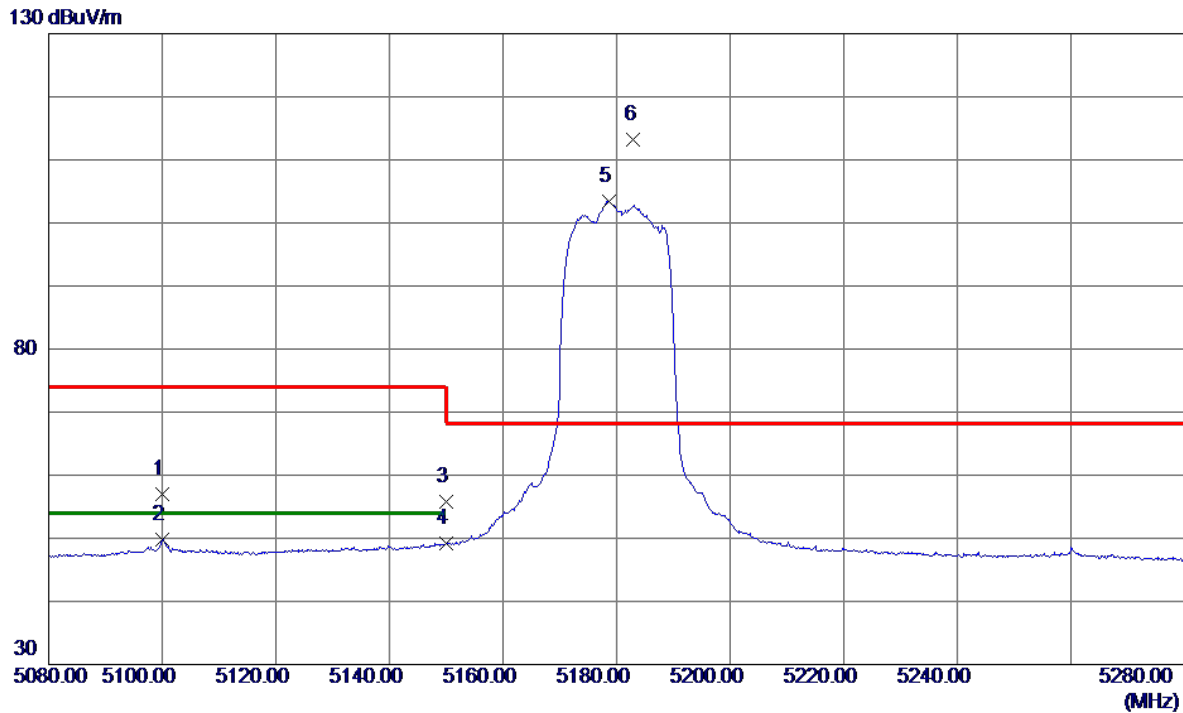

No.	Freq. MHz	Reading Level dBuV/m	Correct Factor dB	Measure ment dBuV/m	Limit dBuV/m	Margin dB	Detector	Comment
1	5100.0000	39.32	17.71	57.03	74.00	-16.97	Peak	
2	5100.0000	32.13	17.71	49.84	54.00	-4.16	AVG	
3	5150.0000	37.95	17.90	55.85	74.00	-18.15	Peak	
4	5150.0000	31.32	17.90	49.22	54.00	-4.78	AVG	
5	5178.6000	85.41	18.01	103.42	999.00	-895.58	AVG	No Limit
6 *	5183.0000	95.18	18.03	113.21	68.20	45.01	Peak	No Limit

**REMARKS:**

- (1) Measurement Value = Reading Level + Correct Factor.
- (2) Margin Level = Measurement Value - Limit Value.



Test Mode	UNII-1_TX AC(VHT20) Mode 5180 MHz	Polarization	Horizontal
-----------	-----------------------------------	--------------	------------

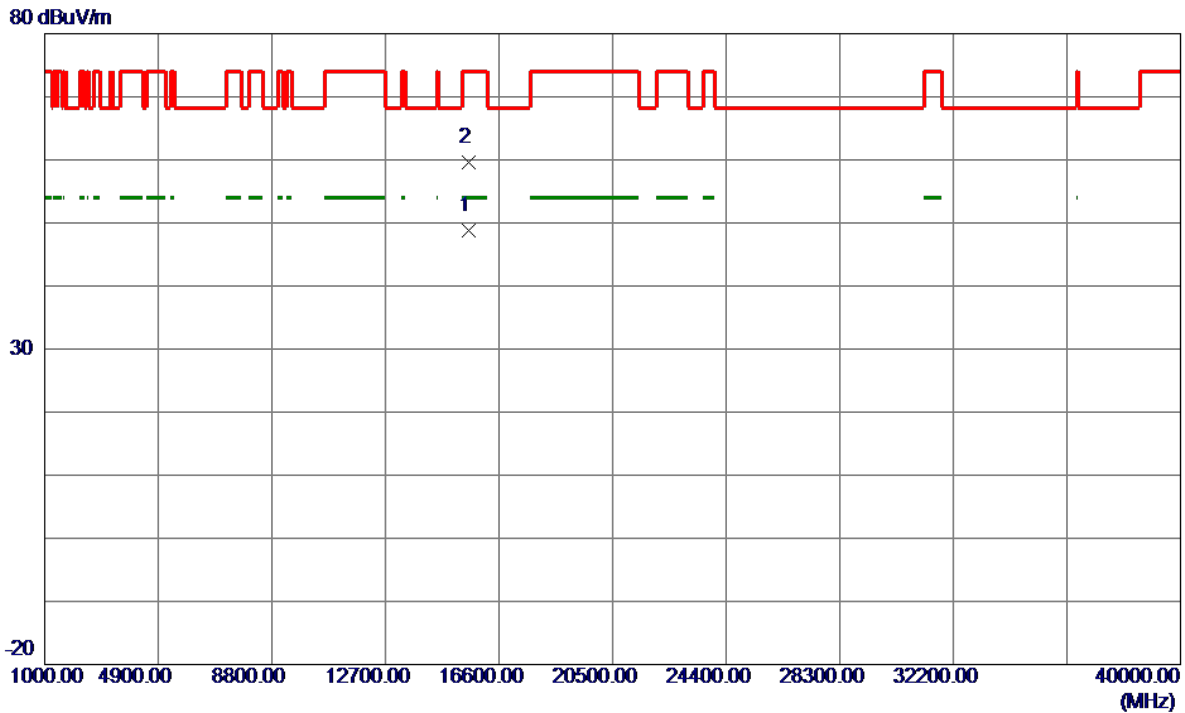

No.	Freq. MHz	Reading Level dBuV/m	Correct Factor dB	Measure ment dBuV/m	Limit dBuV/m	Margin dB	Detector	Comment
1 *	15541.5000	32.79	16.03	48.82	54.00	-5.18	AVG	
2	15546.7000	43.51	16.03	59.54	74.00	-14.46	Peak	

**REMARKS:**

- (1) Measurement Value = Reading Level + Correct Factor.
- (2) Margin Level = Measurement Value - Limit Value.

Test Mode	UNII-1_TX AC(VHT20) Mode 5200 MHz	Polarization	Vertical
-----------	-----------------------------------	--------------	----------

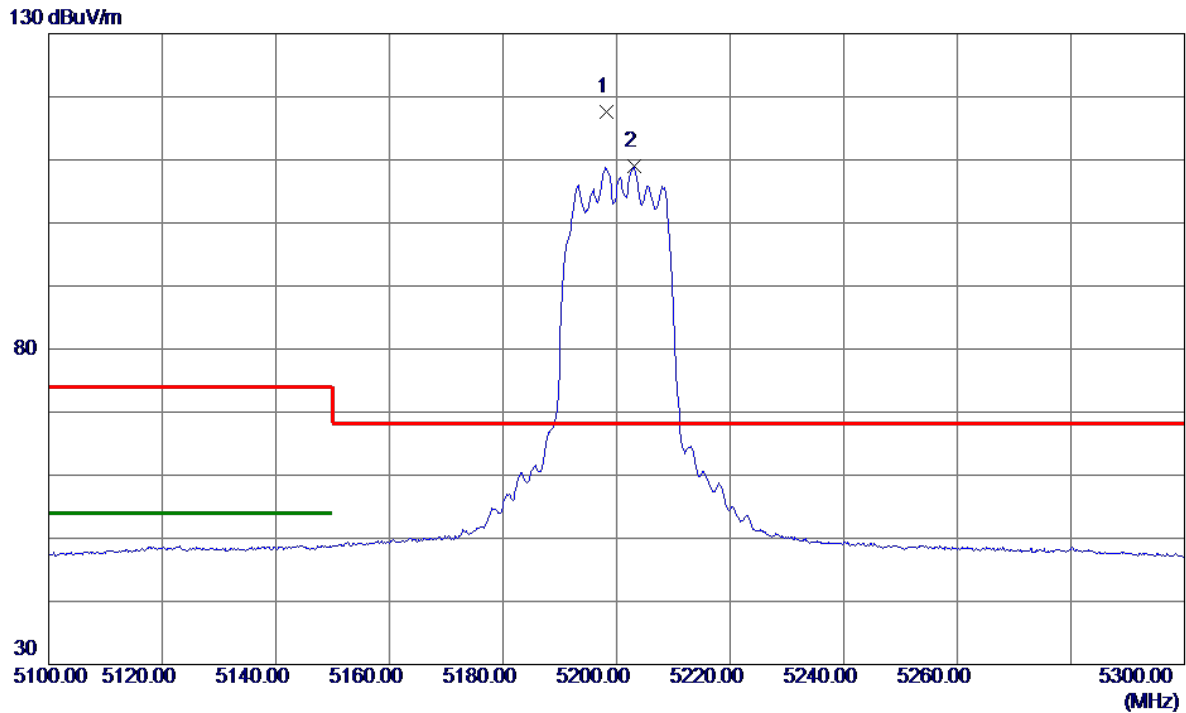

No.	Freq. MHz	Reading Level dBuV/m	Correct Factor dB	Measure ment dBuV/m	Limit dBuV/m	Margin dB	Detector	Comment
1 *	5198.2000	99.44	18.09	117.53	68.20	49.33	Peak	No Limit
2	5203.1000	90.96	18.11	109.07	999.00	-889.93	AVG	No Limit

**REMARKS:**

- (1) Measurement Value = Reading Level + Correct Factor.
- (2) Margin Level = Measurement Value - Limit Value.

Test Mode	UNII-1_TX AC(VHT20) Mode 5200 MHz	Polarization	Vertical
-----------	-----------------------------------	--------------	----------

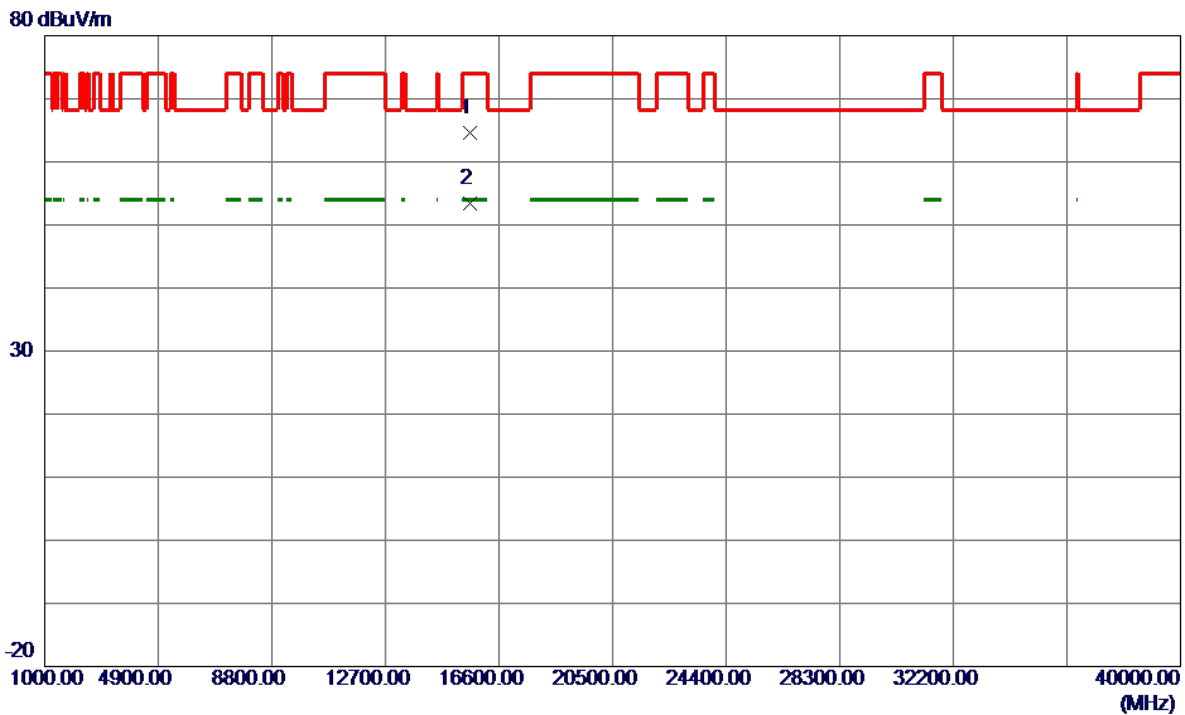

No.	Freq. MHz	Reading Level dBuV/m	Correct Factor dB	Measure ment dBuV/m	Limit dBuV/m	Margin dB	Detector	Comment
1	15596.2400	48.57	16.04	64.61	74.00	-9.39	Peak	
2 *	15600.8900	37.44	16.04	53.48	54.00	-0.52	AVG	

**REMARKS:**

- (1) Measurement Value = Reading Level + Correct Factor.
- (2) Margin Level = Measurement Value - Limit Value.

Test Mode	UNII-1_TX AC(VHT20) Mode 5200 MHz	Polarization	Horizontal
-----------	-----------------------------------	--------------	------------

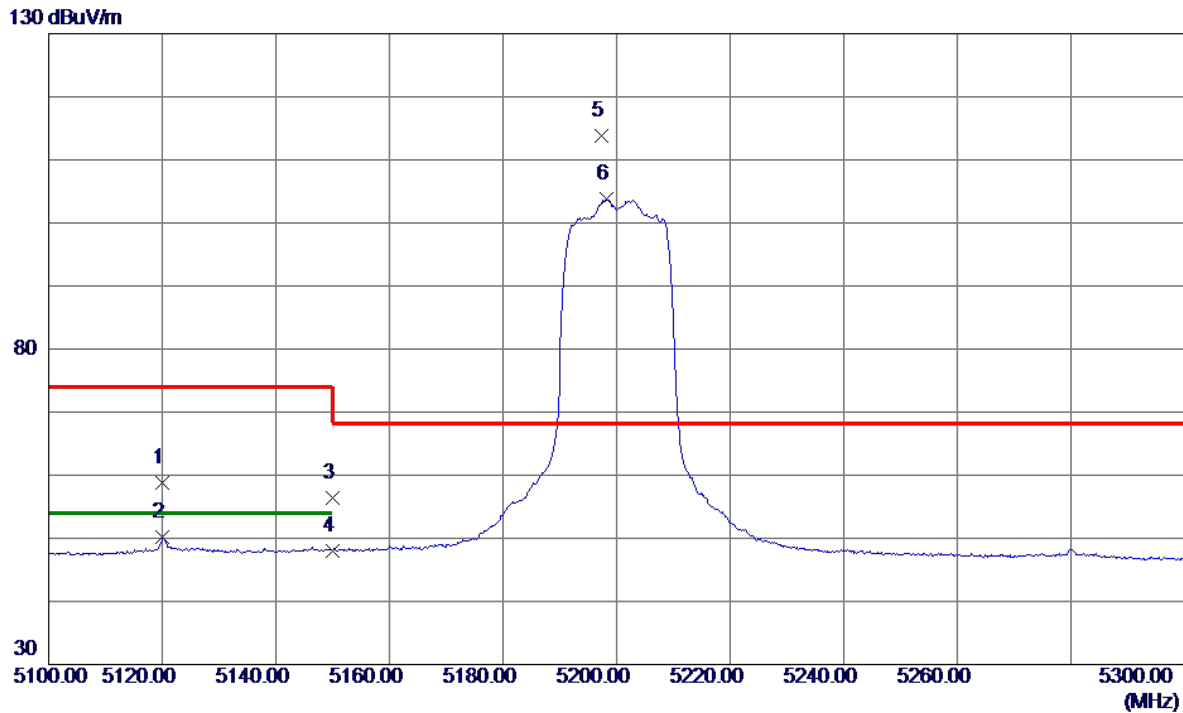

No.	Freq. MHz	Reading Level dBuV/m	Correct Factor dB	Measure ment dBuV/m	Limit dBuV/m	Margin dB	Detector	Comment
1	5120.1000	41.05	17.79	58.84	74.00	-15.16	Peak	
2	5120.1000	32.36	17.79	50.15	54.00	-3.85	AVG	
3	5150.0000	38.51	17.90	56.41	74.00	-17.59	Peak	
4	5150.0000	30.16	17.90	48.06	54.00	-5.94	AVG	
5 *	5197.4000	95.68	18.09	113.77	68.20	45.57	Peak	No Limit
6	5198.3000	85.66	18.09	103.75	999.00	-895.25	AVG	No Limit

**REMARKS:**

- (1) Measurement Value = Reading Level + Correct Factor.
- (2) Margin Level = Measurement Value - Limit Value.

Test Mode	UNII-1_TX AC(VHT20) Mode 5200 MHz	Polarization	Horizontal
-----------	-----------------------------------	--------------	------------

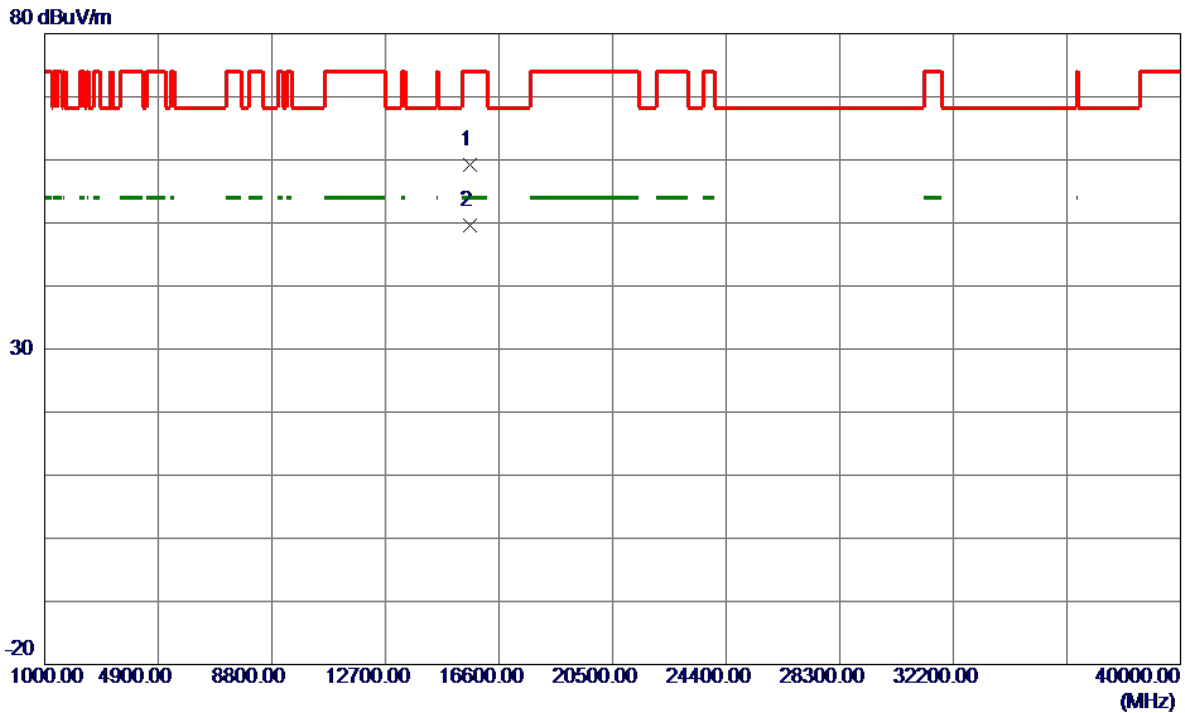

No.	Freq. MHz	Reading Level dBuV/m	Correct Factor dB	Measure ment dBuV/m	Limit dBuV/m	Margin dB	Detector	Comment
1	15591.7500	43.22	16.04	59.26	74.00	-14.74	Peak	
2 *	15596.4000	33.65	16.04	49.69	54.00	-4.31	AVG	

**REMARKS:**

- (1) Measurement Value = Reading Level + Correct Factor.
- (2) Margin Level = Measurement Value - Limit Value.

Test Mode	UNII-1_TX AC(VHT20) Mode 5240 MHz	Polarization	Vertical
-----------	-----------------------------------	--------------	----------

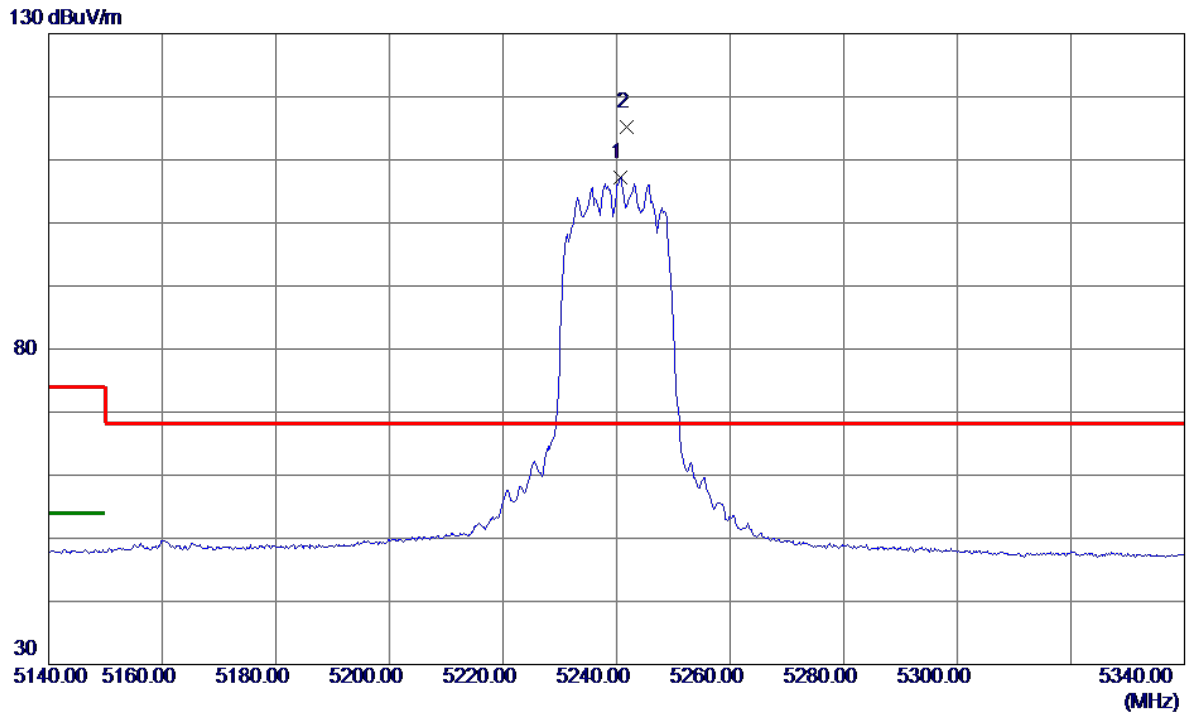

No.	Freq. MHz	Reading Level dBuV/m	Correct Factor dB	Measure ment dBuV/m	Limit dBuV/m	Margin dB	Detector	Comment
1	5240.7000	89.02	18.25	107.27	999.00	-891.73	AVG	No Limit
2 *	5241.8000	97.03	18.26	115.29	68.20	47.09	Peak	No Limit

**REMARKS:**

- (1) Measurement Value = Reading Level + Correct Factor.
- (2) Margin Level = Measurement Value - Limit Value.

Test Mode	UNII-1_TX AC(VHT20) Mode 5240 MHz	Polarization	Vertical
-----------	-----------------------------------	--------------	----------



No.	Freq. MHz	Reading Level dBuV/m	Correct Factor dB	Measure ment dBuV/m	Limit dBuV/m	Margin dB	Detector	Comment
1 *	15719.5700	37.11	16.06	53.17	54.00	-0.83	AVG	
2	15722.1900	47.16	16.06	63.22	74.00	-10.78	Peak	

**REMARKS:**

- (1) Measurement Value = Reading Level + Correct Factor.
- (2) Margin Level = Measurement Value - Limit Value.

Test Mode	UNII-1_TX AC(VHT20) Mode 5240 MHz	Polarization	Horizontal
-----------	-----------------------------------	--------------	------------

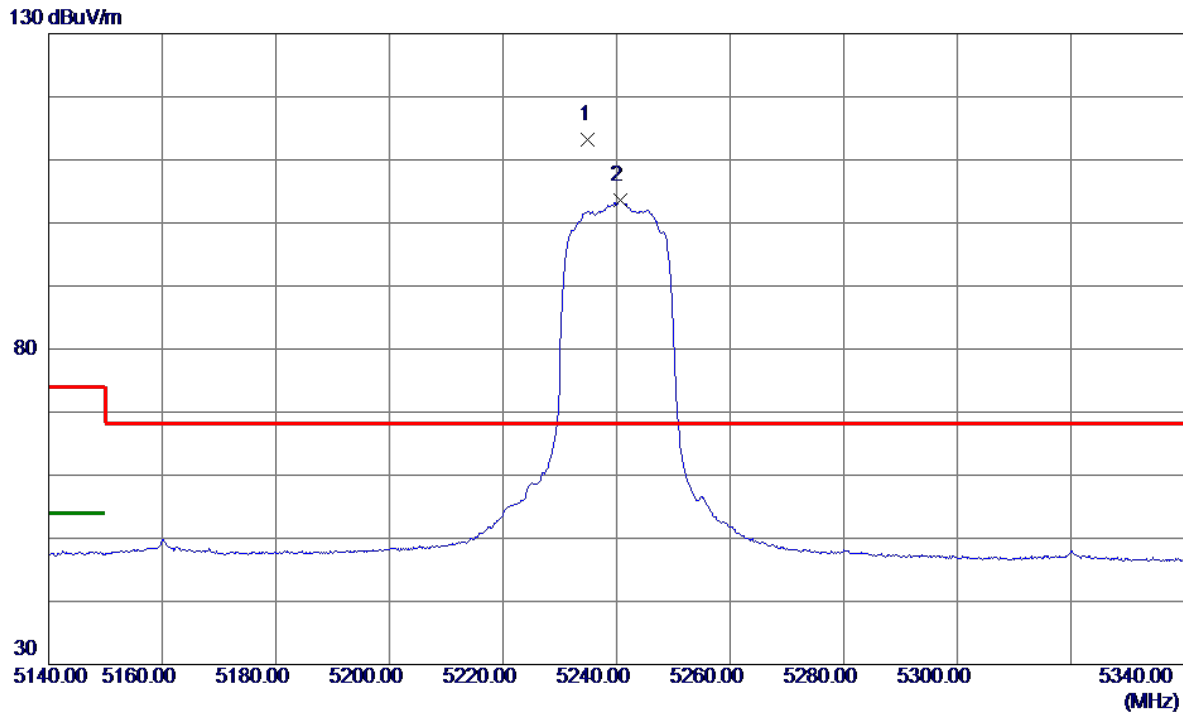

No.	Freq. MHz	Reading Level dBuV/m	Correct Factor dB	Measure ment dBuV/m	Limit dBuV/m	Margin dB	Detector	Comment
1 *	5235.0000	94.97	18.23	113.20	68.20	45.00	Peak	No Limit
2	5240.6000	85.29	18.25	103.54	999.00	-895.46	AVG	No Limit

REMARKS:

- (1) Measurement Value = Reading Level + Correct Factor.
- (2) Margin Level = Measurement Value - Limit Value.



Test Mode	UNII-1_TX AC(VHT20) Mode 5240 MHz	Polarization	Horizontal
-----------	-----------------------------------	--------------	------------



No.	Freq. MHz	Reading Level dBuV/m	Correct Factor dB	Measure ment dBuV/m	Limit dBuV/m	Margin dB	Detector	Comment
1	15717.1500	43.90	16.06	59.96	74.00	-14.04	Peak	
2 *	15722.6500	34.62	16.06	50.68	54.00	-3.32	AVG	

**REMARKS:**

- (1) Measurement Value = Reading Level + Correct Factor.
- (2) Margin Level = Measurement Value - Limit Value.

Test Mode	UNII-1_TX AC(VHT40) Mode 5190 MHz	Polarization	Vertical
-----------	-----------------------------------	--------------	----------

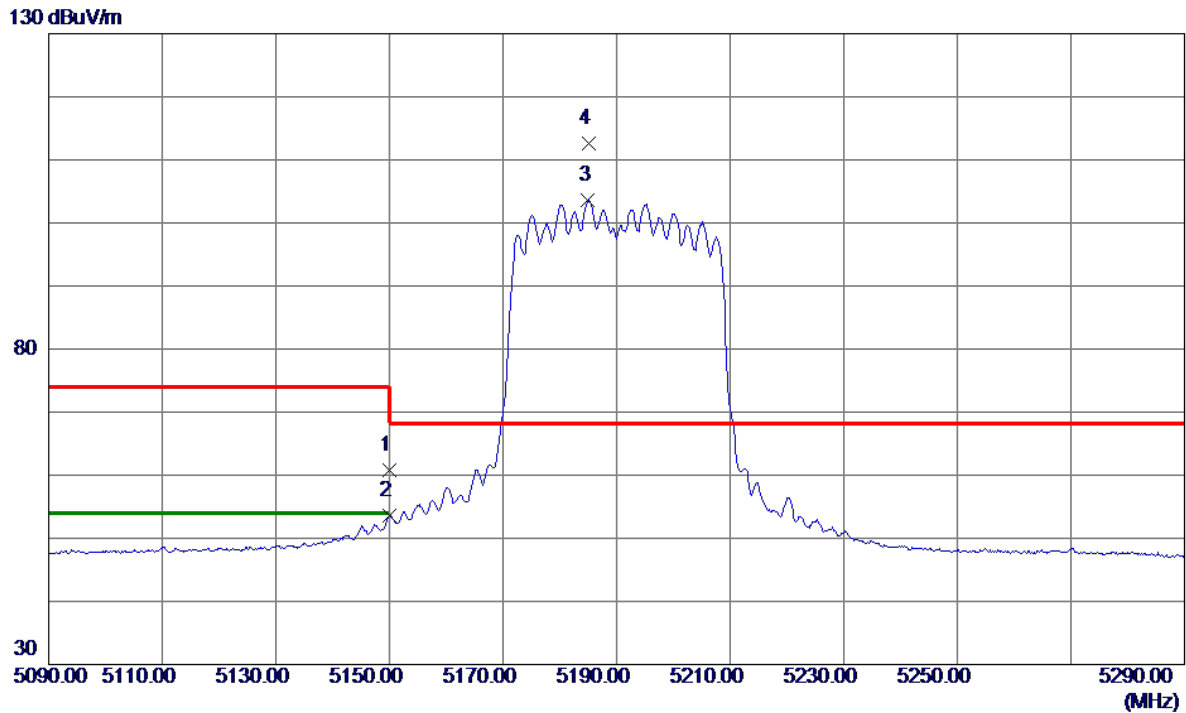

No.	Freq. MHz	Reading Level dBuV/m	Correct Factor dB	Measure ment dBuV/m	Limit dBuV/m	Margin dB	Detector	Comment
1	5150.0000	42.98	17.90	60.88	74.00	-13.12	Peak	
2	5150.0000	35.66	17.90	53.56	54.00	-0.44	AVG	
3	5185.0000	85.60	18.04	103.64	999.00	-895.36	AVG	No Limit
4 *	5185.2000	94.57	18.04	112.61	68.20	44.41	Peak	No Limit

**REMARKS:**

- (1) Measurement Value = Reading Level + Correct Factor.
- (2) Margin Level = Measurement Value - Limit Value.

Test Mode	UNII-1_TX AC(VHT40) Mode 5190 MHz	Polarization	Vertical
-----------	-----------------------------------	--------------	----------

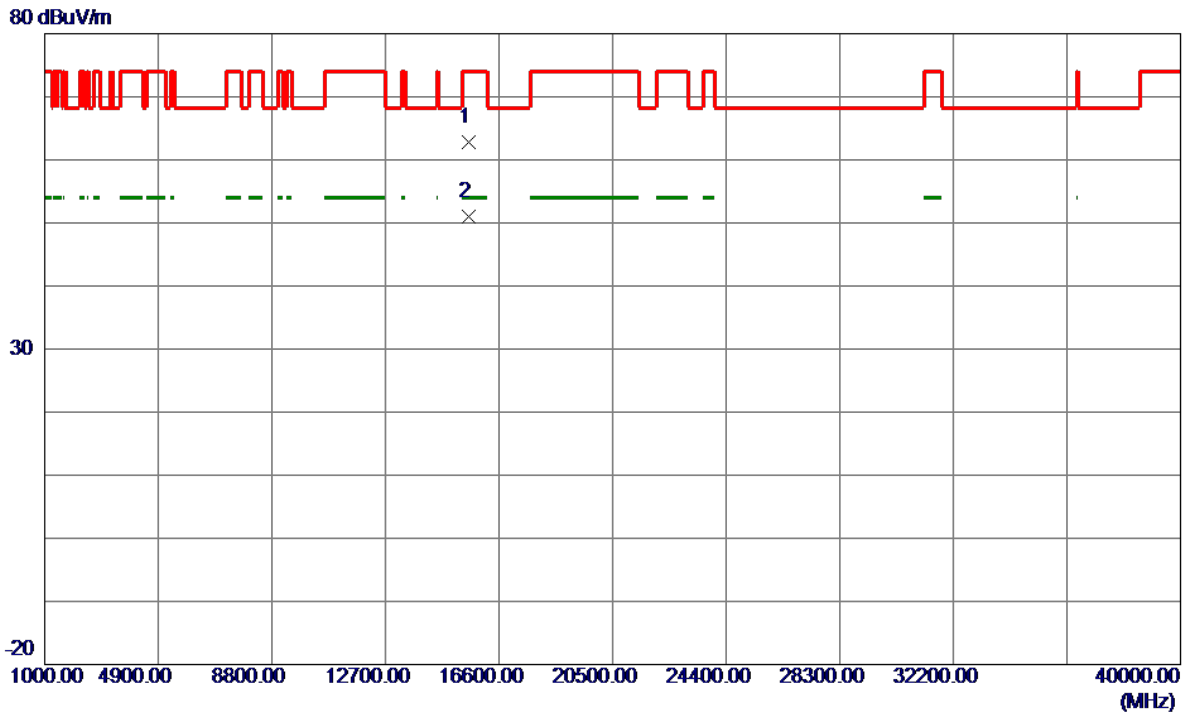

No.	Freq. MHz	Reading Level dBuV/m	Correct Factor dB	Measure ment dBuV/m	Limit dBuV/m	Margin dB	Detector	Comment
1	15565.6400	46.69	16.03	62.72	74.00	-11.28	Peak	
2 *	15570.5100	34.97	16.03	51.00	54.00	-3.00	AVG	

**REMARKS:**

- (1) Measurement Value = Reading Level + Correct Factor.
- (2) Margin Level = Measurement Value - Limit Value.

Test Mode	UNII-1_TX AC(VHT40) Mode 5190 MHz	Polarization	Horizontal
-----------	-----------------------------------	--------------	------------

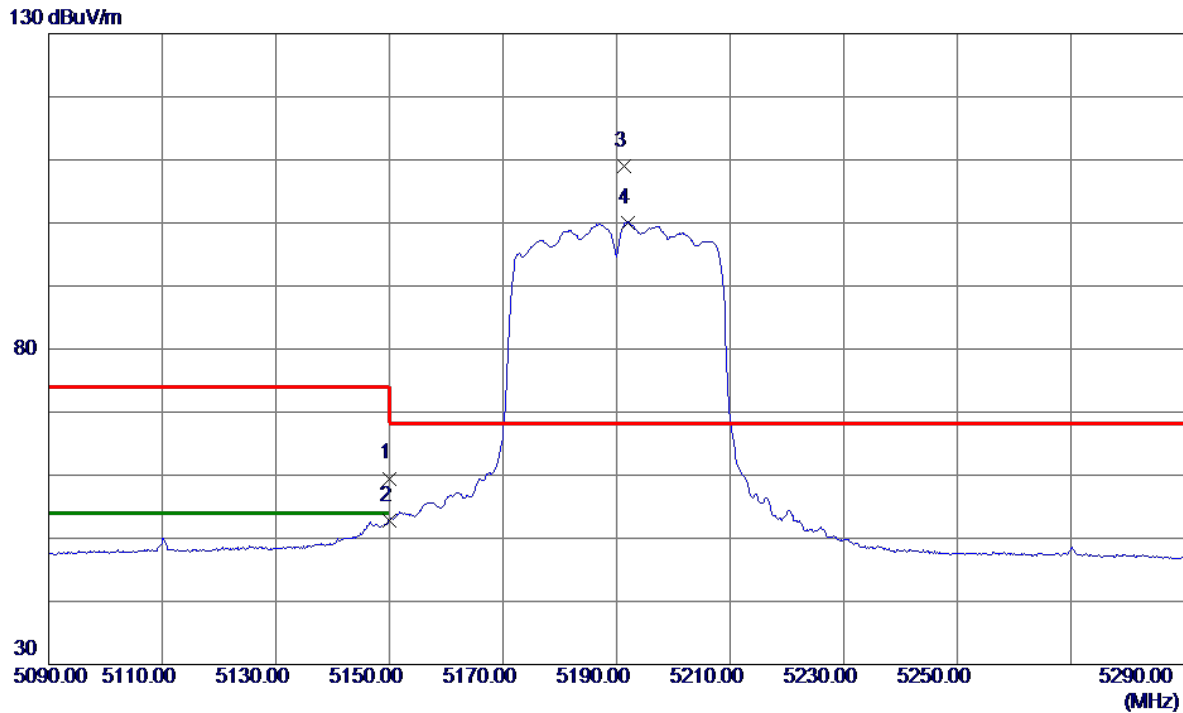

No.	Freq. MHz	Reading Level dBuV/m	Correct Factor dB	Measure ment dBuV/m	Limit dBuV/m	Margin dB	Detector	Comment
1	5150.0000	41.60	17.90	59.50	74.00	-14.50	Peak	
2	5150.0000	34.99	17.90	52.89	54.00	-1.11	AVG	
3 *	5191.3000	90.97	18.06	109.03	68.20	40.83	Peak	No Limit
4	5192.1000	82.03	18.07	100.10	999.00	-898.90	AVG	No Limit

REMARKS:

- (1) Measurement Value = Reading Level + Correct Factor.
- (2) Margin Level = Measurement Value - Limit Value.

Test Mode	UNII-1_TX AC(VHT40) Mode 5190 MHz	Polarization	Horizontal
-----------	-----------------------------------	--------------	------------



No.	Freq. MHz	Reading Level dBuV/m	Correct Factor dB	Measure ment dBuV/m	Limit dBuV/m	Margin dB	Detector	Comment
1	15578.5500	36.90	16.03	52.93	74.00	-21.07	Peak	
2 *	15580.7000	26.89	16.03	42.92	54.00	-11.08	AVG	

**REMARKS:**

- (1) Measurement Value = Reading Level + Correct Factor.
- (2) Margin Level = Measurement Value - Limit Value.

Test Mode	UNII-1_TX AC(VHT40) Mode 5230 MHz	Polarization	Vertical
-----------	-----------------------------------	--------------	----------

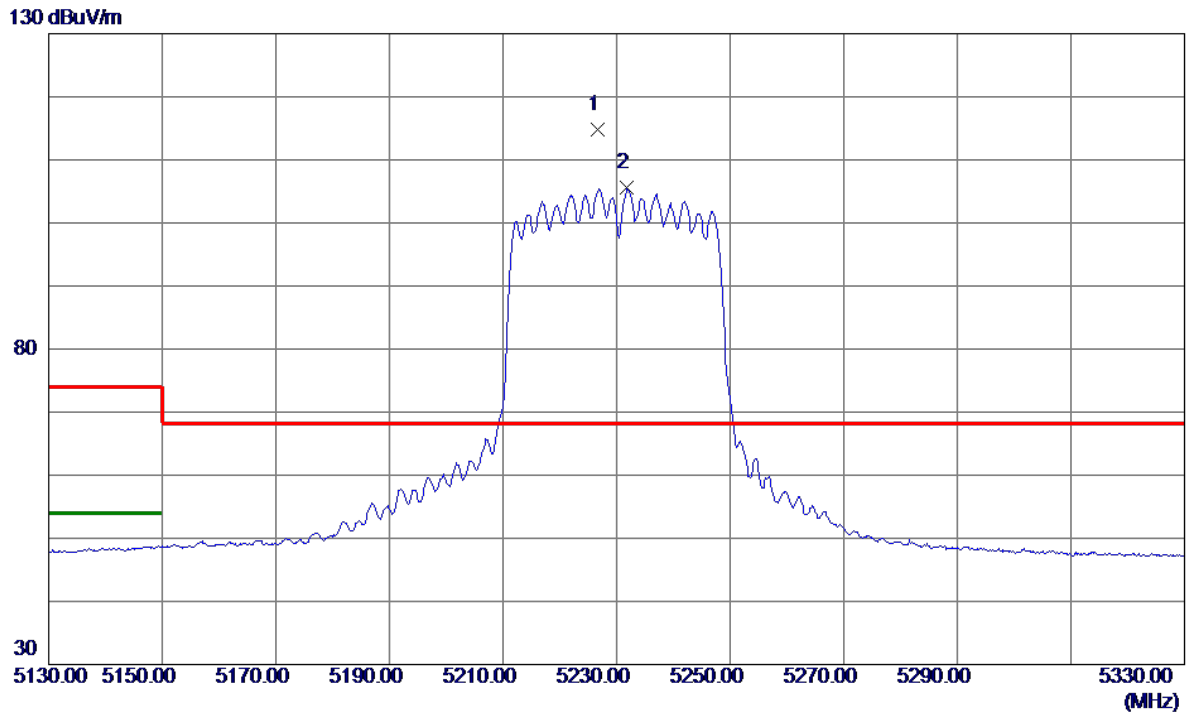

No.	Freq. MHz	Reading Level dBuV/m	Correct Factor dB	Measure ment dBuV/m	Limit dBuV/m	Margin dB	Detector	Comment
1 *	5226.7000	96.61	18.20	114.81	68.20	46.61	Peak	No Limit
2	5231.8000	87.35	18.22	105.57	999.00	-893.43	AVG	No Limit

**REMARKS:**

- (1) Measurement Value = Reading Level + Correct Factor.
- (2) Margin Level = Measurement Value - Limit Value.

Test Mode	UNII-1_TX AC(VHT40) Mode 5230 MHz	Polarization	Vertical
-----------	-----------------------------------	--------------	----------

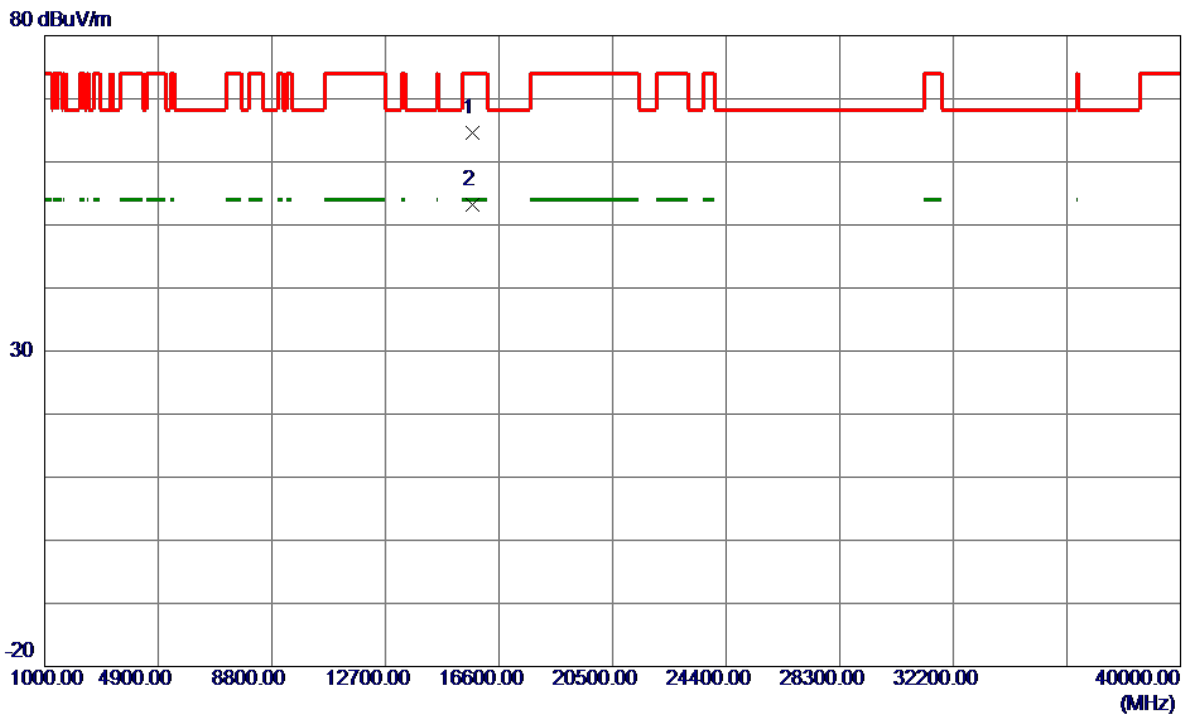

No.	Freq. MHz	Reading Level dBuV/m	Correct Factor dB	Measure ment dBuV/m	Limit dBuV/m	Margin dB	Detector	Comment
1	15685.6700	48.57	16.05	64.62	74.00	-9.38	Peak	
2 *	15693.2800	37.18	16.05	53.23	54.00	-0.77	AVG	

**REMARKS:**

- (1) Measurement Value = Reading Level + Correct Factor.
- (2) Margin Level = Measurement Value - Limit Value.

Test Mode	UNII-1_TX AC(VHT40) Mode 5230 MHz	Polarization	Horizontal
-----------	-----------------------------------	--------------	------------

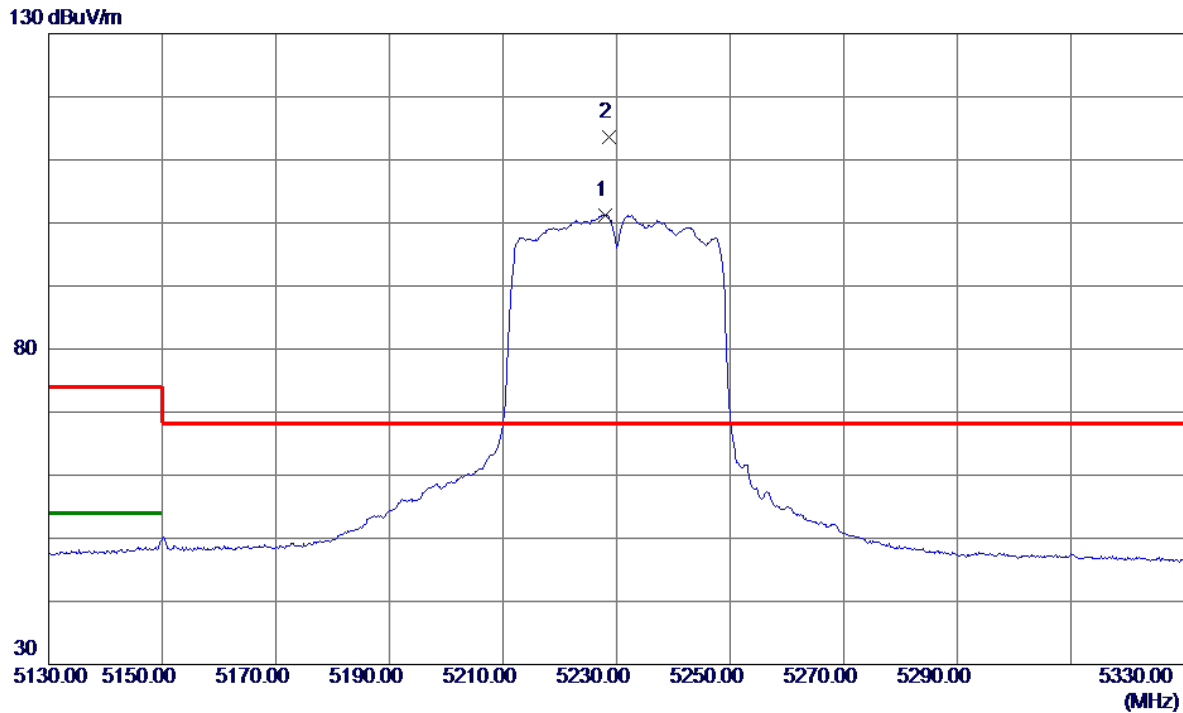

No.	Freq. MHz	Reading Level dBuV/m	Correct Factor dB	Measure ment dBuV/m	Limit dBuV/m	Margin dB	Detector	Comment
1	5228.0000	83.05	18.20	101.25	999.00	-897.75	AVG	No Limit
2 *	5228.7000	95.31	18.21	113.52	68.20	45.32	Peak	No Limit

**REMARKS:**

- (1) Measurement Value = Reading Level + Correct Factor.
- (2) Margin Level = Measurement Value - Limit Value.



Test Mode	UNII-1_TX AC(VHT40) Mode 5230 MHz	Polarization	Horizontal
-----------	-----------------------------------	--------------	------------

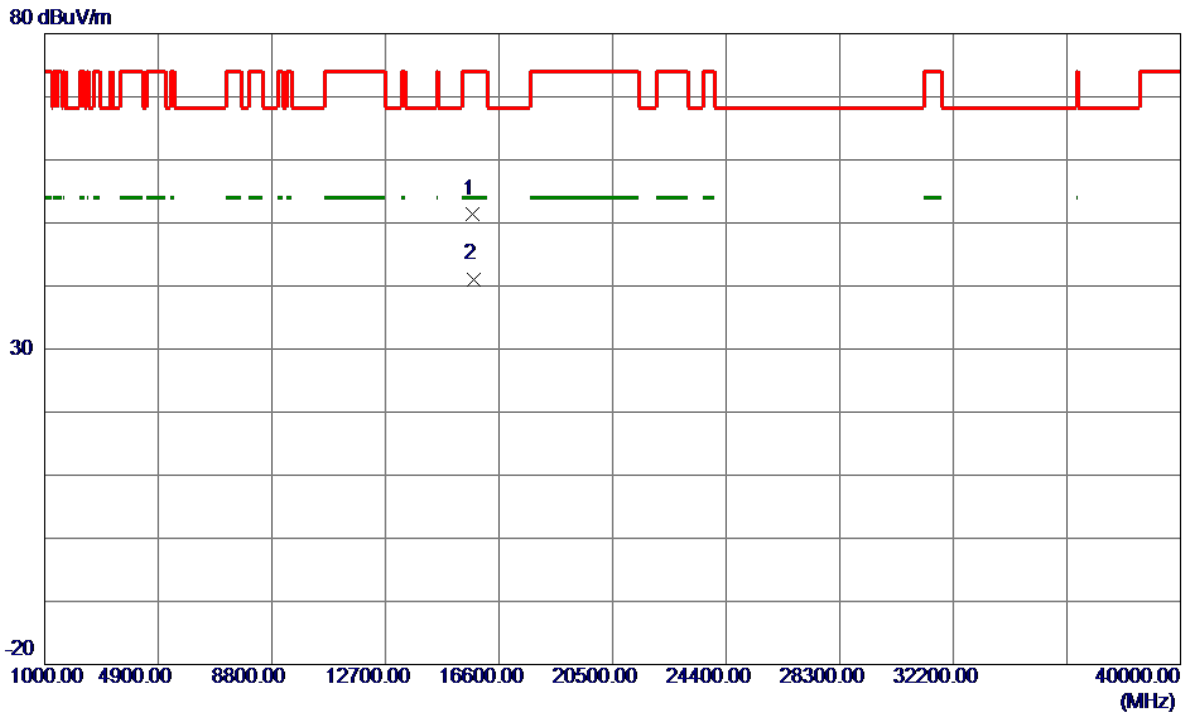

No.	Freq. MHz	Reading Level dBuV/m	Correct Factor dB	Measure ment dBuV/m	Limit dBuV/m	Margin dB	Detector	Comment
1	15679.3500	35.42	16.05	51.47	74.00	-22.53	Peak	
2 *	15711.9500	25.04	16.06	41.10	54.00	-12.90	AVG	

**REMARKS:**

- (1) Measurement Value = Reading Level + Correct Factor.
- (2) Margin Level = Measurement Value - Limit Value.

Test Mode	UNII-1_TX AC(VHT80) Mode 5210 MHz	Polarization	Vertical
-----------	-----------------------------------	--------------	----------

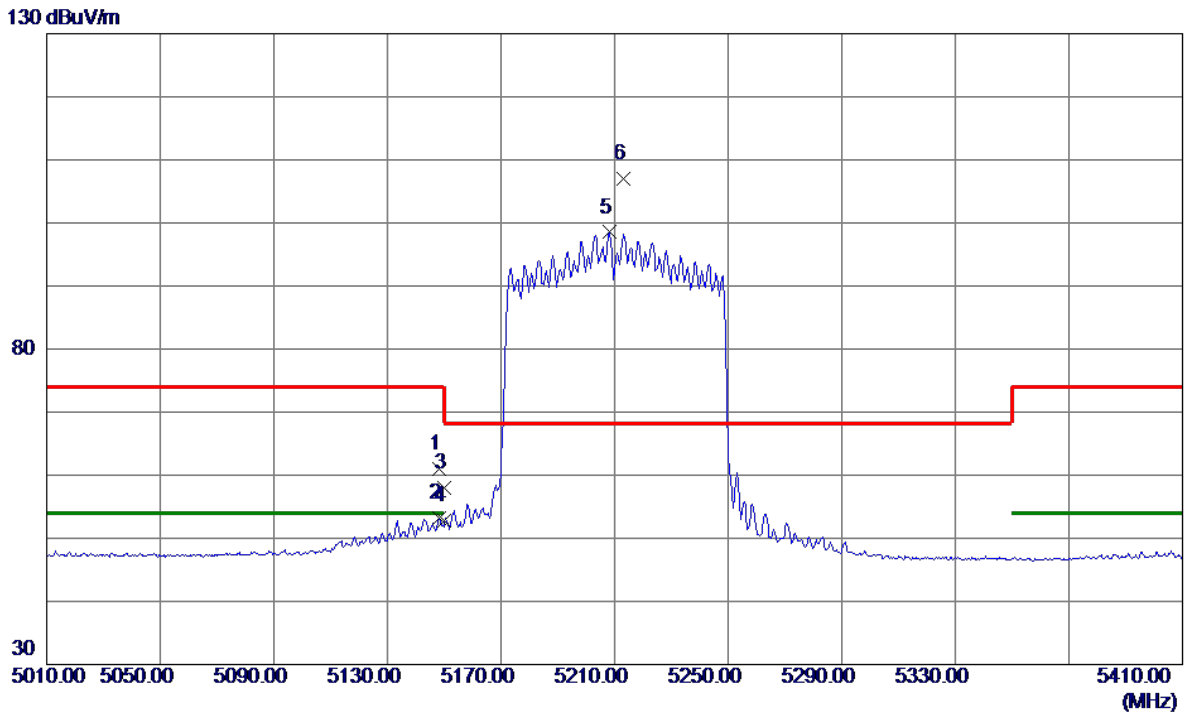

No.	Freq. MHz	Reading Level dBuV/m	Correct Factor dB	Measure ment dBuV/m	Limit dBuV/m	Margin dB	Detector	Comment
1	5148.2000	43.08	17.90	60.98	74.00	-13.02	Peak	
2	5148.2000	35.35	17.90	53.25	54.00	-0.75	AVG	
3	5150.0000	40.14	17.90	58.04	74.00	-15.96	Peak	
4	5150.0000	34.86	17.90	52.76	54.00	-1.24	AVG	
5	5208.2000	80.37	18.13	98.50	999.00	-900.50	AVG	No Limit
6 *	5213.2000	88.81	18.15	106.96	68.20	38.76	Peak	No Limit

**REMARKS:**

- (1) Measurement Value = Reading Level + Correct Factor.
- (2) Margin Level = Measurement Value - Limit Value.

Test Mode	UNII-1_TX AC(VHT80) Mode 5210 MHz	Polarization	Vertical
-----------	-----------------------------------	--------------	----------

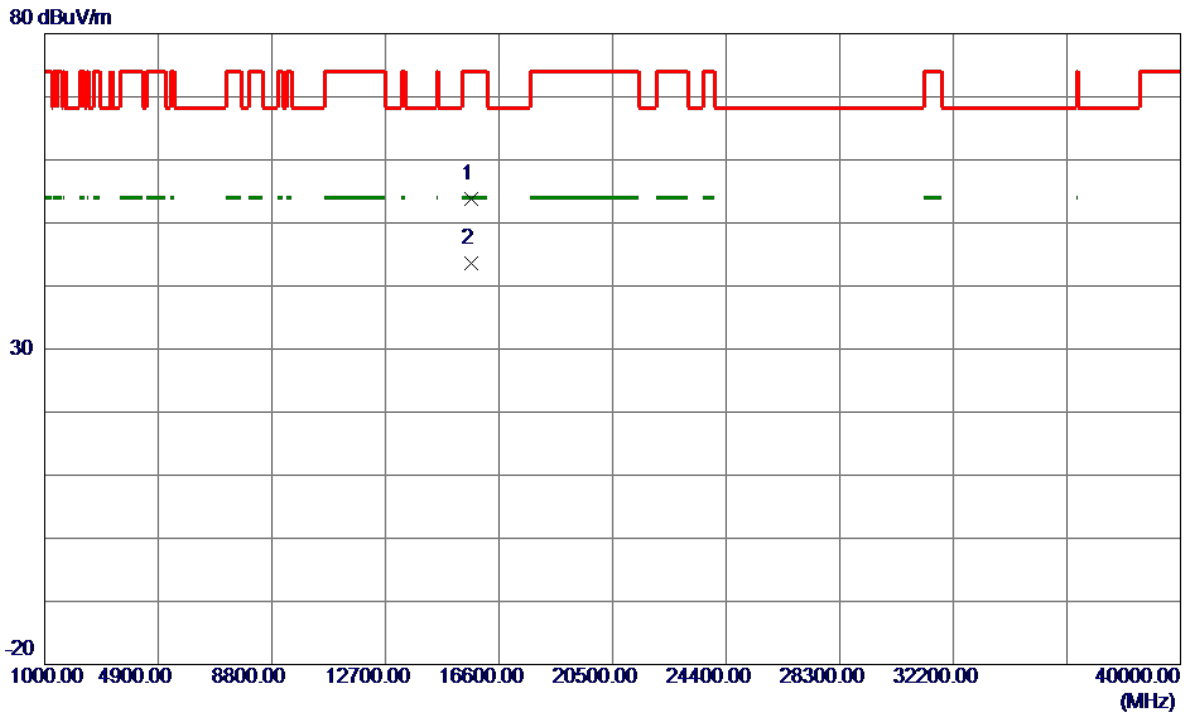

No.	Freq. MHz	Reading Level dBuV/m	Correct Factor dB	Measure ment dBuV/m	Limit dBuV/m	Margin dB	Detector	Comment
1	15631.4600	37.80	16.04	53.84	74.00	-20.16	Peak	
2 *	15638.4600	27.53	16.04	43.57	54.00	-10.43	AVG	

**REMARKS:**

- (1) Measurement Value = Reading Level + Correct Factor.
- (2) Margin Level = Measurement Value - Limit Value.

Test Mode	UNII-1_TX AC(VHT80) Mode 5210 MHz	Polarization	Horizontal
-----------	-----------------------------------	--------------	------------

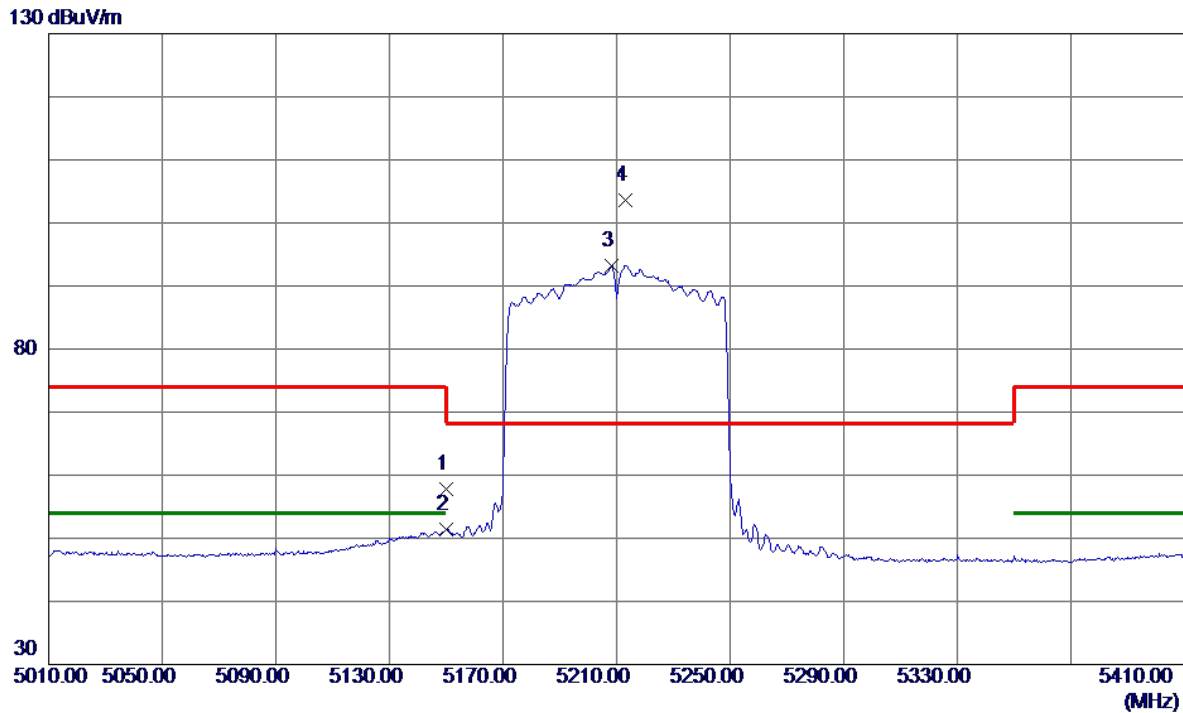

No.	Freq. MHz	Reading Level dBuV/m	Correct Factor dB	Measure ment dBuV/m	Limit dBuV/m	Margin dB	Detector	Comment
1	5150.0000	39.88	17.90	57.78	74.00	-16.22	Peak	
2	5150.0000	33.55	17.90	51.45	54.00	-2.55	AVG	
3	5208.2000	75.09	18.13	93.22	999.00	-905.78	AVG	No Limit
4 *	5213.2000	85.52	18.15	103.67	68.20	35.47	Peak	No Limit

REMARKS:

- (1) Measurement Value = Reading Level + Correct Factor.
- (2) Margin Level = Measurement Value - Limit Value.

Test Mode	UNII-1_TX AC(VHT80) Mode 5210 MHz	Polarization	Horizontal
-----------	-----------------------------------	--------------	------------

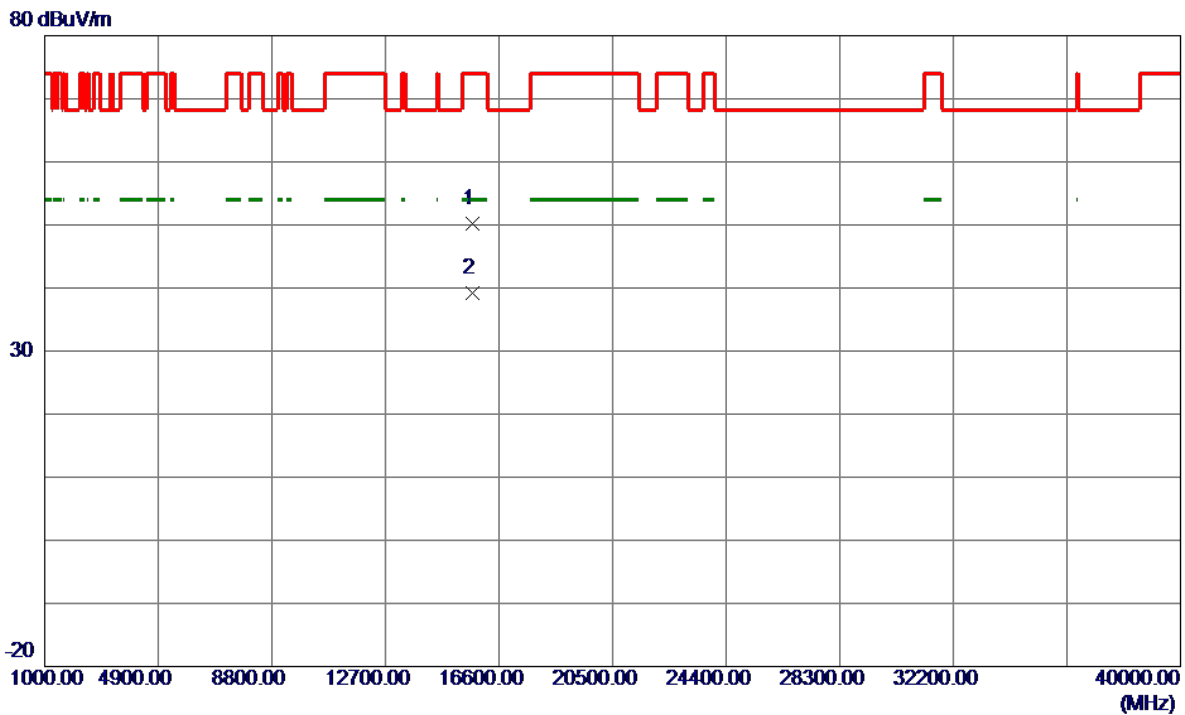

No.	Freq. MHz	Reading Level dBuV/m	Correct Factor dB	Measure ment dBuV/m	Limit dBuV/m	Margin dB	Detector	Comment
1	15709.8600	34.19	16.06	50.25	74.00	-23.75	Peak	
2 *	15710.1450	23.13	16.06	39.19	54.00	-14.81	AVG	

**REMARKS:**

- (1) Measurement Value = Reading Level + Correct Factor.
- (2) Margin Level = Measurement Value - Limit Value.

Test Mode	UNII-3_TX A Mode 5745 MHz	Polarization	Vertical
-----------	---------------------------	--------------	----------

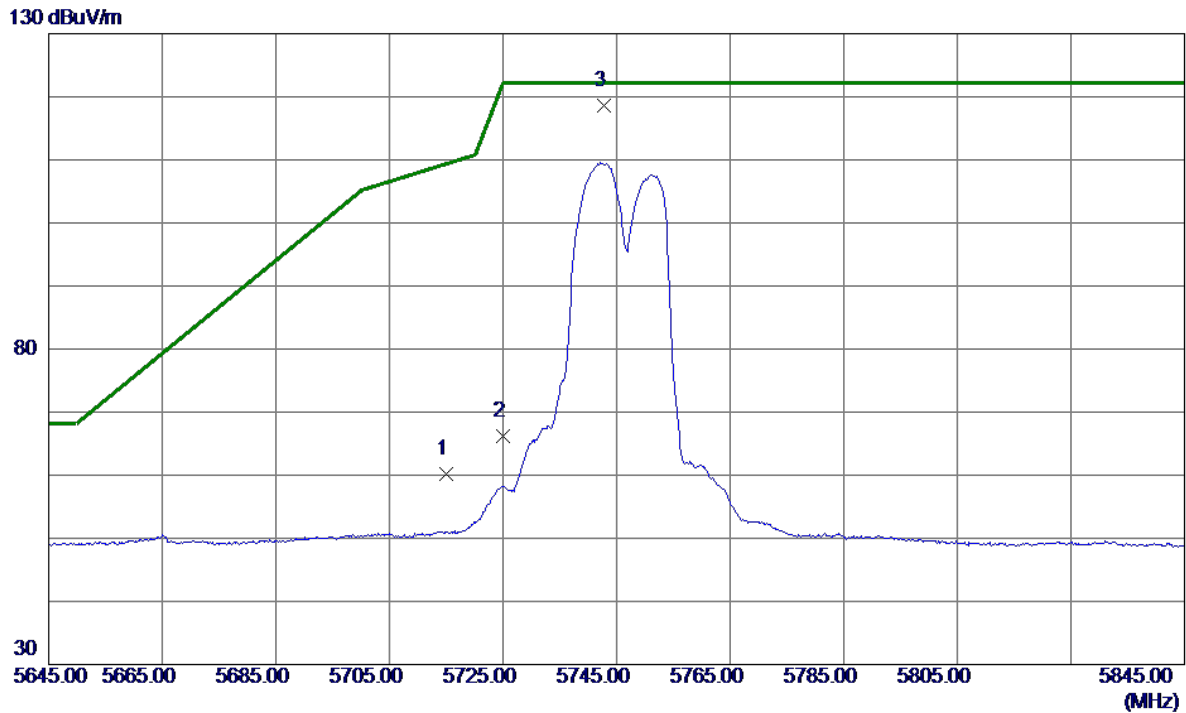

No.	Freq. MHz	Reading Level dBuV/m	Correct Factor dB	Measure ment dBuV/m	Limit dBuV/m	Margin dB	Detector	Comment
1	5715.0000	40.26	19.85	60.11	109.40	-49.29	Peak	
2	5725.0000	46.35	19.88	66.23	122.20	-55.97	Peak	
3 *	5742.7000	98.62	19.93	118.55	122.20	-3.65	Peak	No Limit

**REMARKS:**

- (1) Measurement Value = Reading Level + Correct Factor.
- (2) Margin Level = Measurement Value - Limit Value.

Test Mode	UNII-3_TX A Mode 5745 MHz	Polarization	Vertical
-----------	---------------------------	--------------	----------

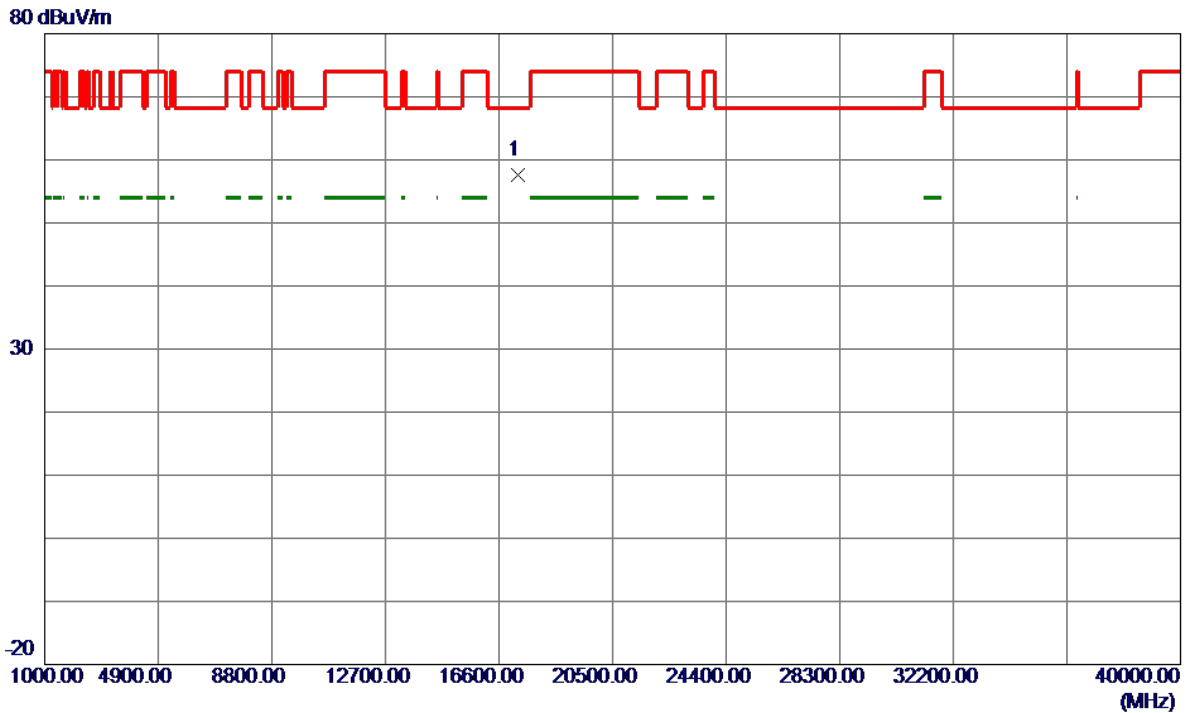

No.	Freq. MHz	Reading Level dBuV/m	Correct Factor dB	Measure ment dBuV/m	Limit dBuV/m	Margin dB	Detector	Comment
1 *	17236.0700	37.11	20.48	57.59	68.20	-10.61	Peak	

**REMARKS:**

- (1) Measurement Value = Reading Level + Correct Factor.
- (2) Margin Level = Measurement Value - Limit Value.

Test Mode	UNII-3_TX A Mode 5745 MHz	Polarization	Horizontal
-----------	---------------------------	--------------	------------

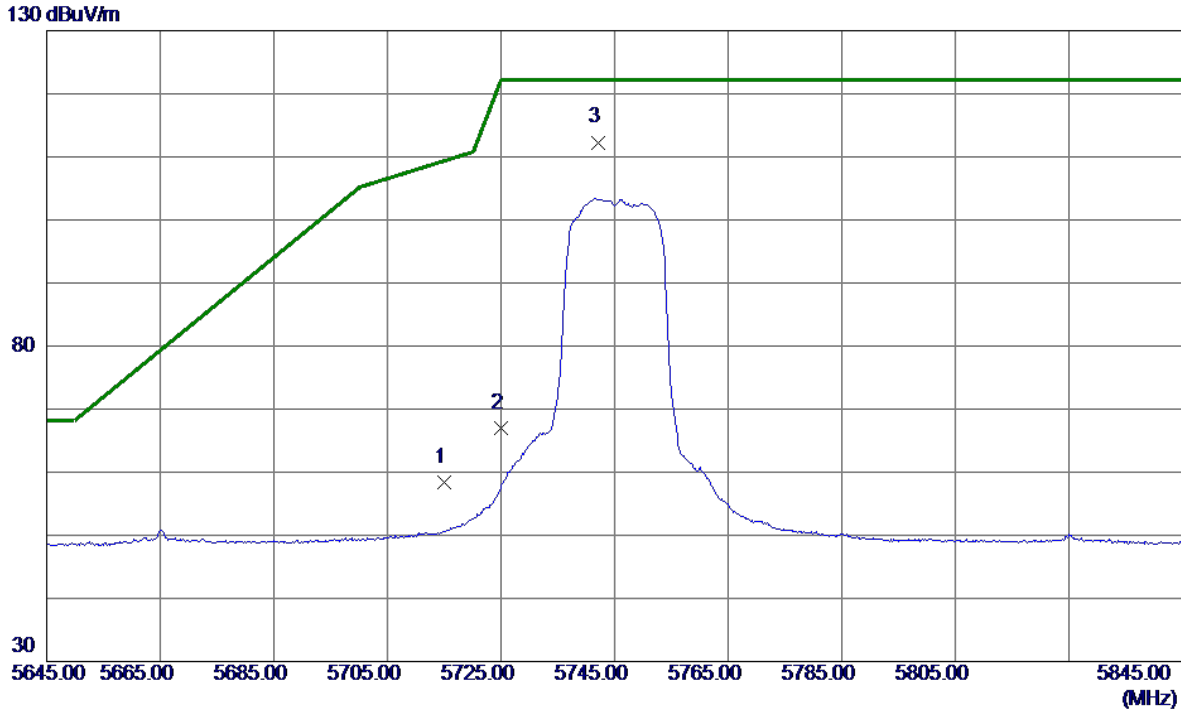

No.	Freq. MHz	Reading Level dBuV/m	Correct Factor dB	Measure ment dBuV/m	Limit dBuV/m	Margin dB	Detector	Comment
1	5715.0000	38.56	19.85	58.41	109.40	-50.99	Peak	
2	5725.0000	47.14	19.88	67.02	122.20	-55.18	Peak	
3 *	5742.2000	92.37	19.93	112.30	122.20	-9.90	Peak	No Limit

**REMARKS:**

- (1) Measurement Value = Reading Level + Correct Factor.
- (2) Margin Level = Measurement Value - Limit Value.



Test Mode	UNII-3_TX A Mode 5745 MHz	Polarization	Horizontal
-----------	---------------------------	--------------	------------

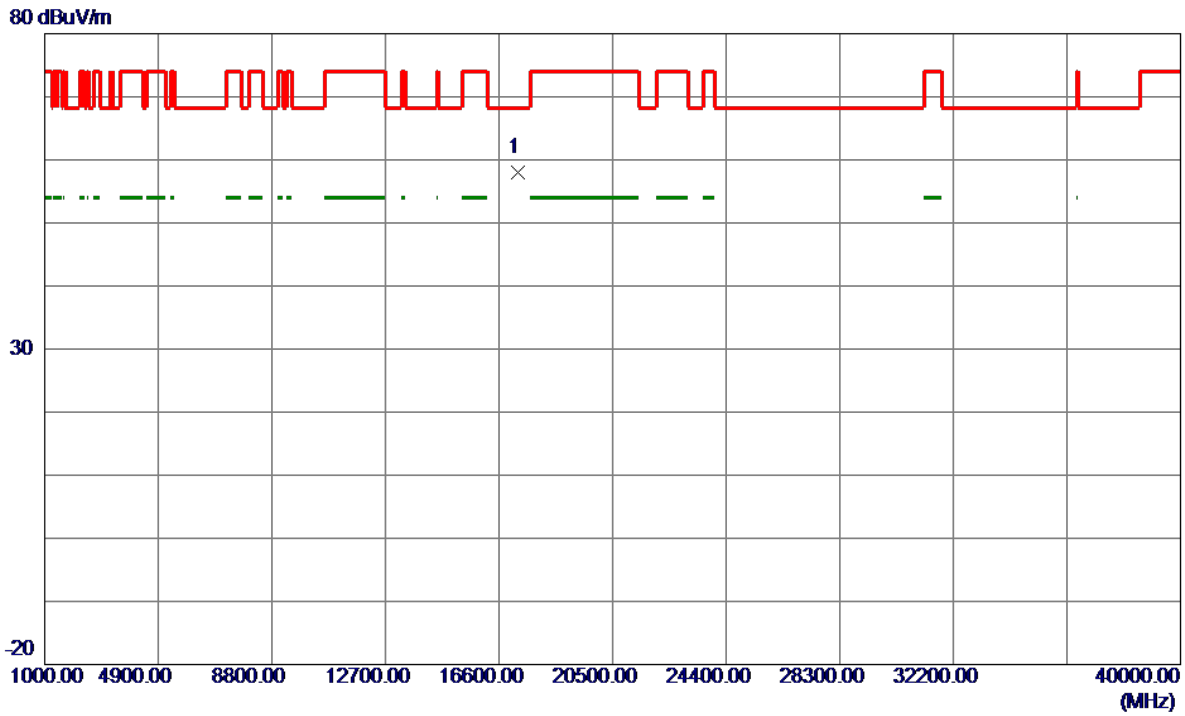

No.	Freq. MHz	Reading Level dBuV/m	Correct Factor dB	Measure ment dBuV/m	Limit dBuV/m	Margin dB	Detector	Comment
1 *	17237.3400	37.56	20.49	58.05	68.20	-10.15	Peak	

**REMARKS:**

- (1) Measurement Value = Reading Level + Correct Factor.
- (2) Margin Level = Measurement Value - Limit Value.

Test Mode	UNII-3_TX A Mode 5785 MHz	Polarization	Vertical
-----------	---------------------------	--------------	----------

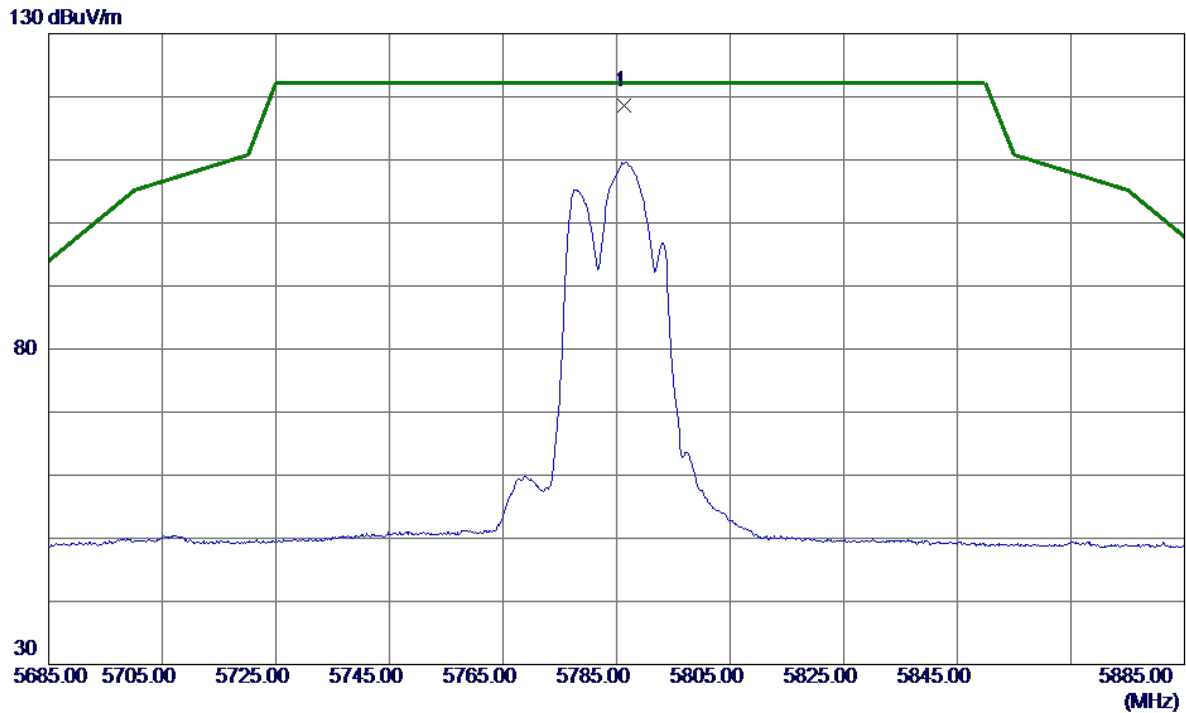

No.	Freq. MHz	Reading Level dBuV/m	Correct Factor dB	Measure ment dBuV/m	Limit dBuV/m	Margin dB	Detector	Comment
1 *	5786.3000	98.55	20.05	118.60	122.20	-3.60	Peak	No Limit

**REMARKS:**

- (1) Measurement Value = Reading Level + Correct Factor.
- (2) Margin Level = Measurement Value - Limit Value.

Test Mode	UNII-3_TX A Mode 5785 MHz	Polarization	Vertical
-----------	---------------------------	--------------	----------

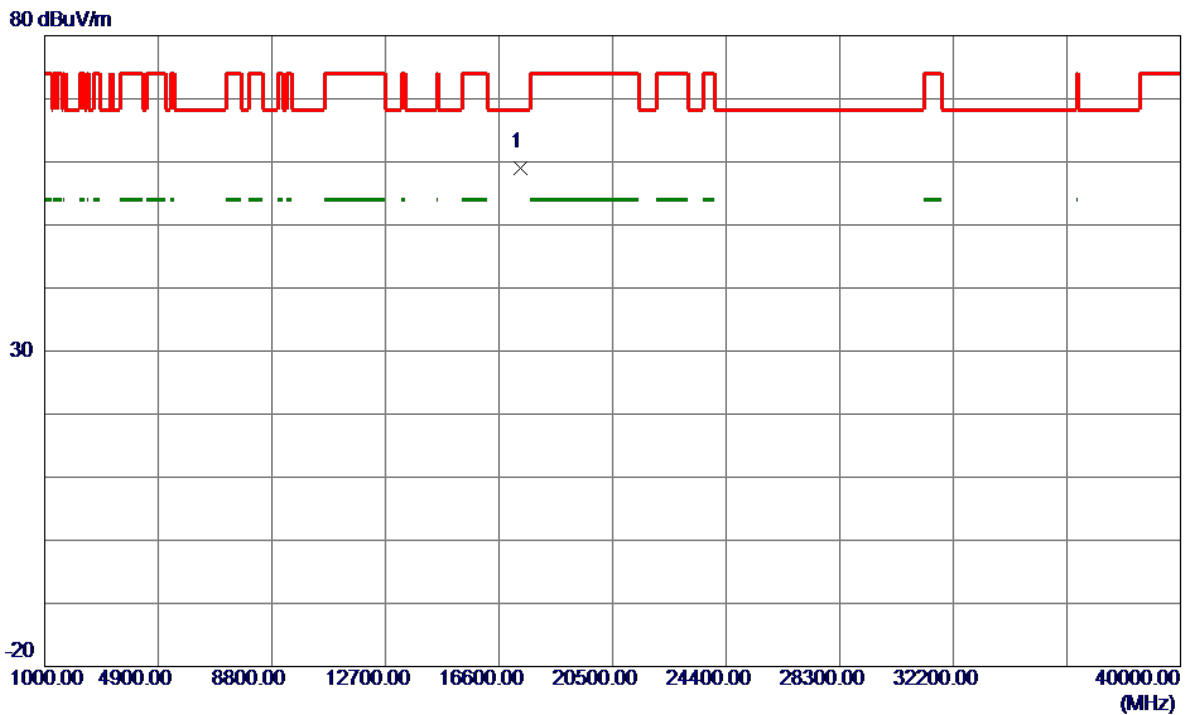

No.	Freq. MHz	Reading Level dBuV/m	Correct Factor dB	Measure ment dBuV/m	Limit dBuV/m	Margin dB	Detector	Comment
1 *	17356.8600	38.15	20.95	59.10	68.20	-9.10	Peak	

**REMARKS:**

- (1) Measurement Value = Reading Level + Correct Factor.
- (2) Margin Level = Measurement Value - Limit Value.

Test Mode	UNII-3_TX A Mode 5785 MHz	Polarization	Horizontal
-----------	---------------------------	--------------	------------

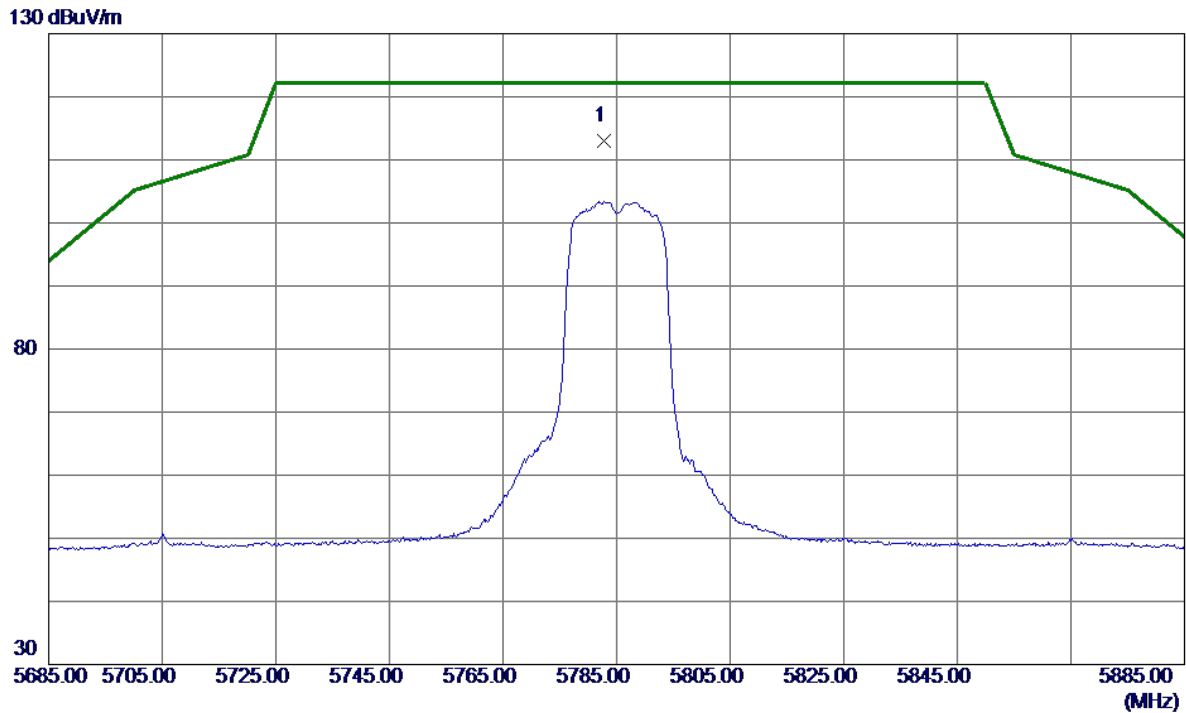

No.	Freq. MHz	Reading Level dBuV/m	Correct Factor dB	Measure ment dBuV/m	Limit dBuV/m	Margin dB	Detector	Comment
1 *	5782.8000	92.86	20.04	112.90	122.20	-9.30	Peak	No Limit

**REMARKS:**

- (1) Measurement Value = Reading Level + Correct Factor.
- (2) Margin Level = Measurement Value - Limit Value.

Test Mode	UNII-3_TX A Mode 5785 MHz	Polarization	Horizontal
-----------	---------------------------	--------------	------------

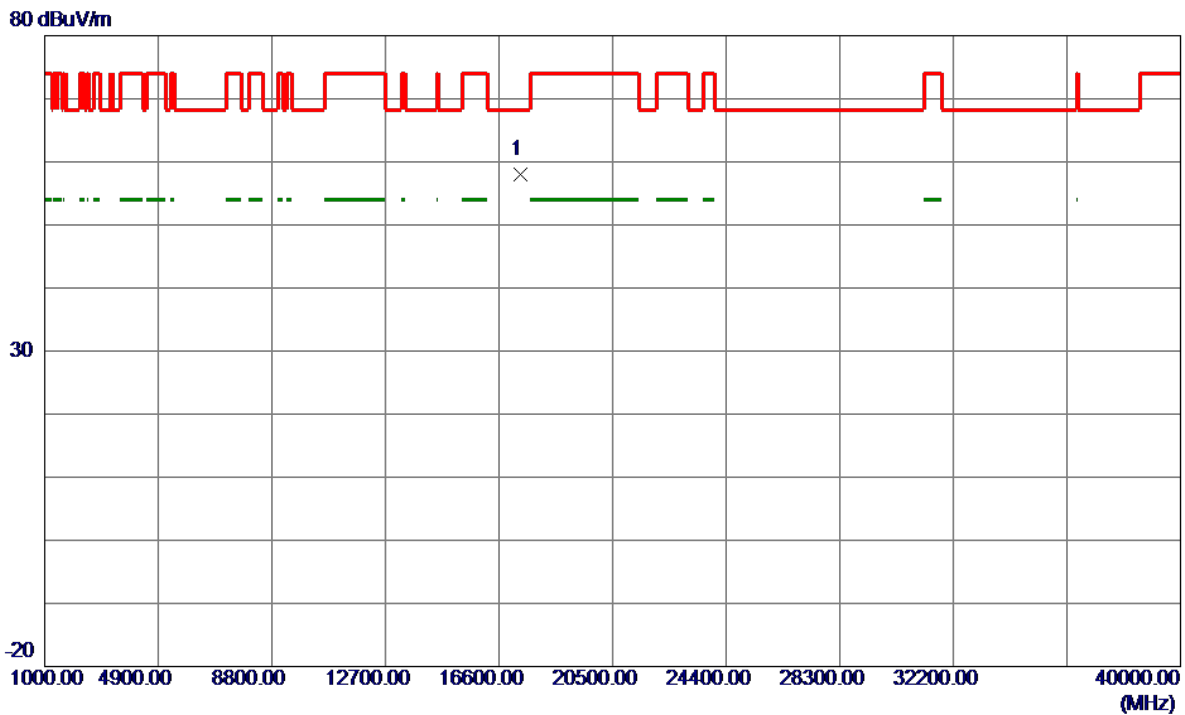

No.	Freq. MHz	Reading Level dBuV/m	Correct Factor dB	Measure ment dBuV/m	Limit dBuV/m	Margin dB	Detector	Comment
1 *	17357.8200	37.14	20.95	58.09	68.20	-10.11	Peak	

**REMARKS:**

- (1) Measurement Value = Reading Level + Correct Factor.
- (2) Margin Level = Measurement Value - Limit Value.

Test Mode	UNII-3_TX A Mode 5825 MHz	Polarization	Vertical
-----------	---------------------------	--------------	----------

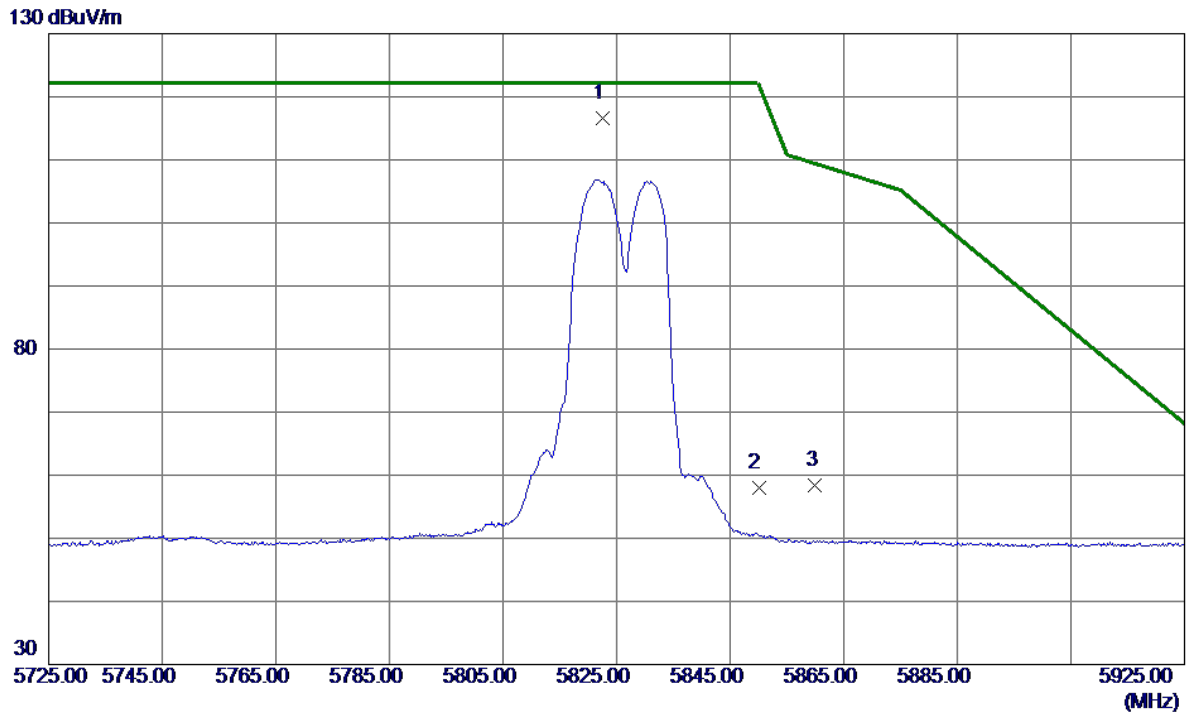

No.	Freq. MHz	Reading Level dBuV/m	Correct Factor dB	Measure ment dBuV/m	Limit dBuV/m	Margin dB	Detector	Comment
1 *	5822.6000	96.36	20.15	116.51	122.20	-5.69	Peak	No Limit
2	5850.0000	37.82	20.23	58.05	122.20	-64.15	Peak	
3	5860.0000	38.08	20.26	58.34	109.40	-51.06	Peak	

**REMARKS:**

- (1) Measurement Value = Reading Level + Correct Factor.
- (2) Margin Level = Measurement Value - Limit Value.

Test Mode	UNII-3_TX A Mode 5825 MHz	Polarization	Vertical
-----------	---------------------------	--------------	----------

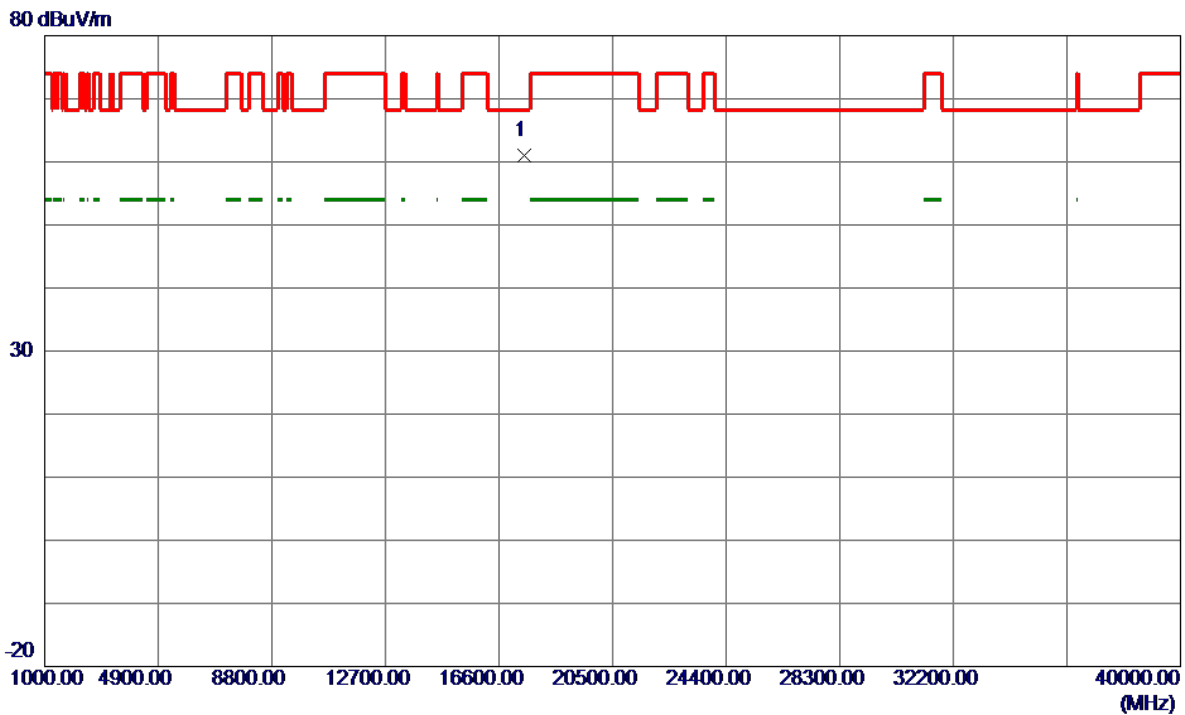

No.	Freq. MHz	Reading Level dBuV/m	Correct Factor dB	Measure ment dBuV/m	Limit dBuV/m	Margin dB	Detector	Comment
1 *	17476.4800	39.57	21.41	60.98	68.20	-7.22	Peak	

**REMARKS:**

- (1) Measurement Value = Reading Level + Correct Factor.
- (2) Margin Level = Measurement Value - Limit Value.

Test Mode	UNII-3_TX A Mode 5825 MHz	Polarization	Horizontal
-----------	---------------------------	--------------	------------

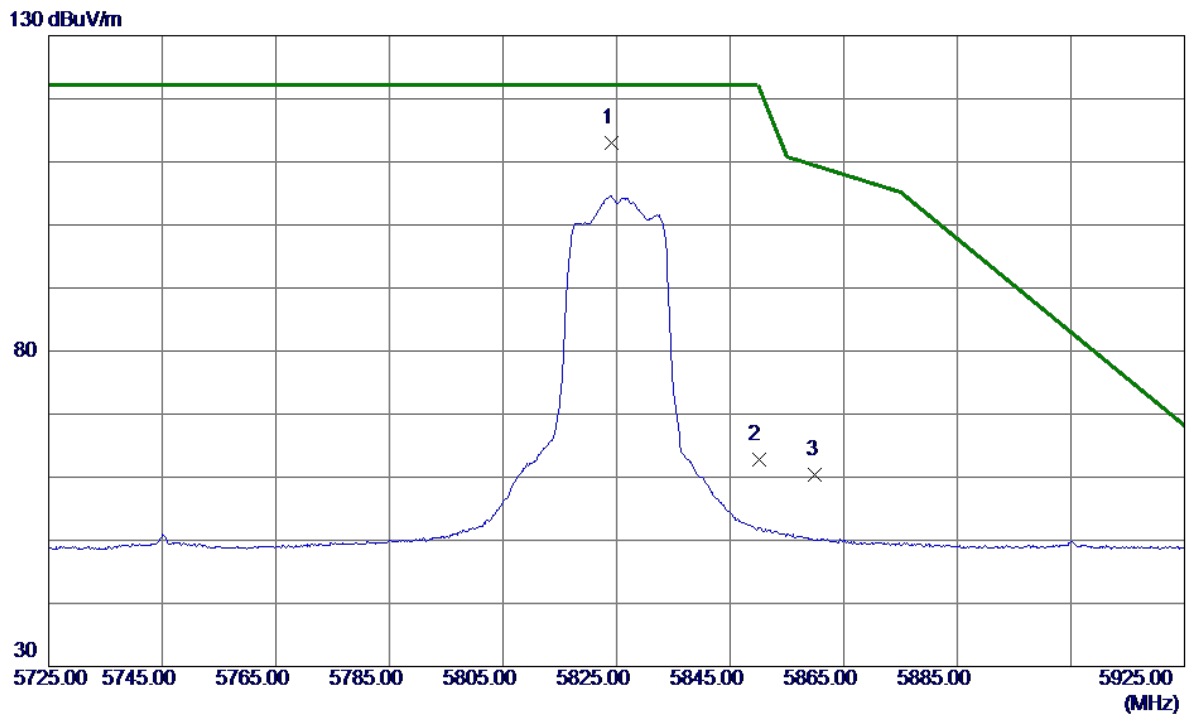

No.	Freq. MHz	Reading Level dBuV/m	Correct Factor dB	Measure ment dBuV/m	Limit dBuV/m	Margin dB	Detector	Comment
1 *	5824.1000	92.78	20.16	112.94	122.20	-9.26	Peak	No Limit
2	5850.0000	42.58	20.23	62.81	122.20	-59.39	Peak	
3	5860.0000	40.21	20.26	60.47	109.40	-48.93	Peak	

REMARKS:

- (1) Measurement Value = Reading Level + Correct Factor.
- (2) Margin Level = Measurement Value - Limit Value.



Test Mode	UNII-3_TX A Mode 5825 MHz	Polarization	Horizontal
-----------	---------------------------	--------------	------------

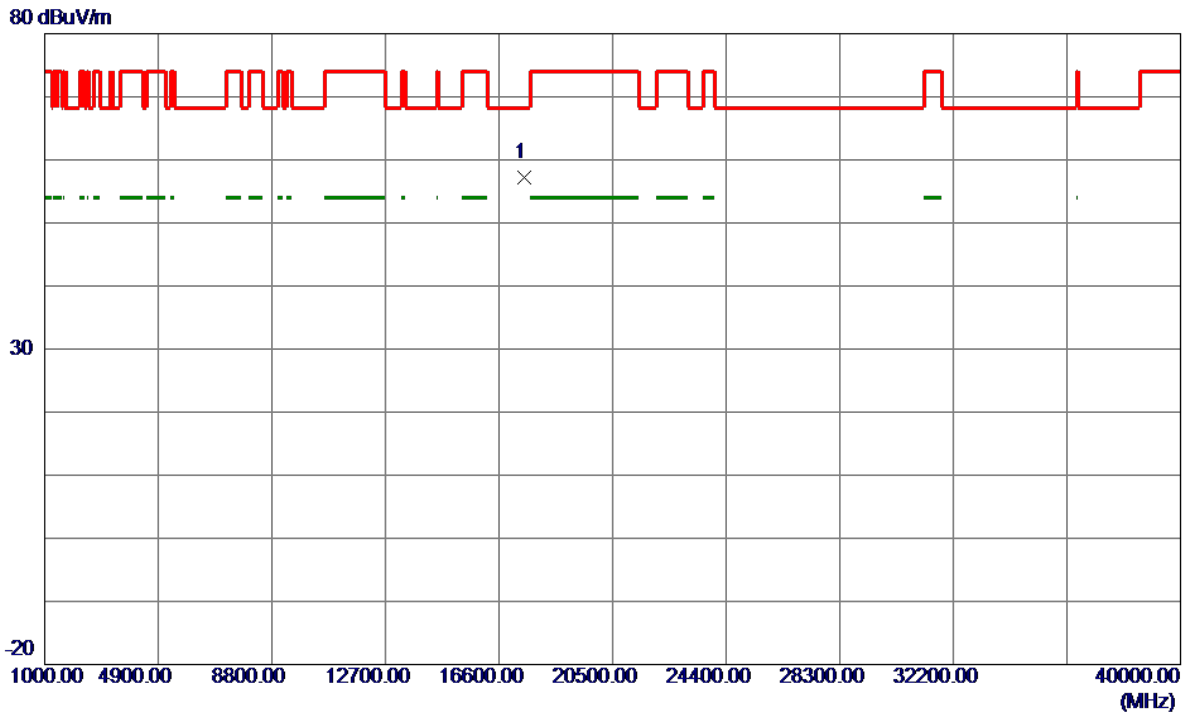

No.	Freq. MHz	Reading Level dBuV/m	Correct Factor dB	Measure ment dBuV/m	Limit dBuV/m	Margin dB	Detector	Comment
1 *	17475.7500	35.82	21.41	57.23	68.20	-10.97	Peak	

**REMARKS:**

- (1) Measurement Value = Reading Level + Correct Factor.
- (2) Margin Level = Measurement Value - Limit Value.

Test Mode	UNII-3_TX AC(VHT20) Mode 5745 MHz	Polarization	Vertical
-----------	-----------------------------------	--------------	----------

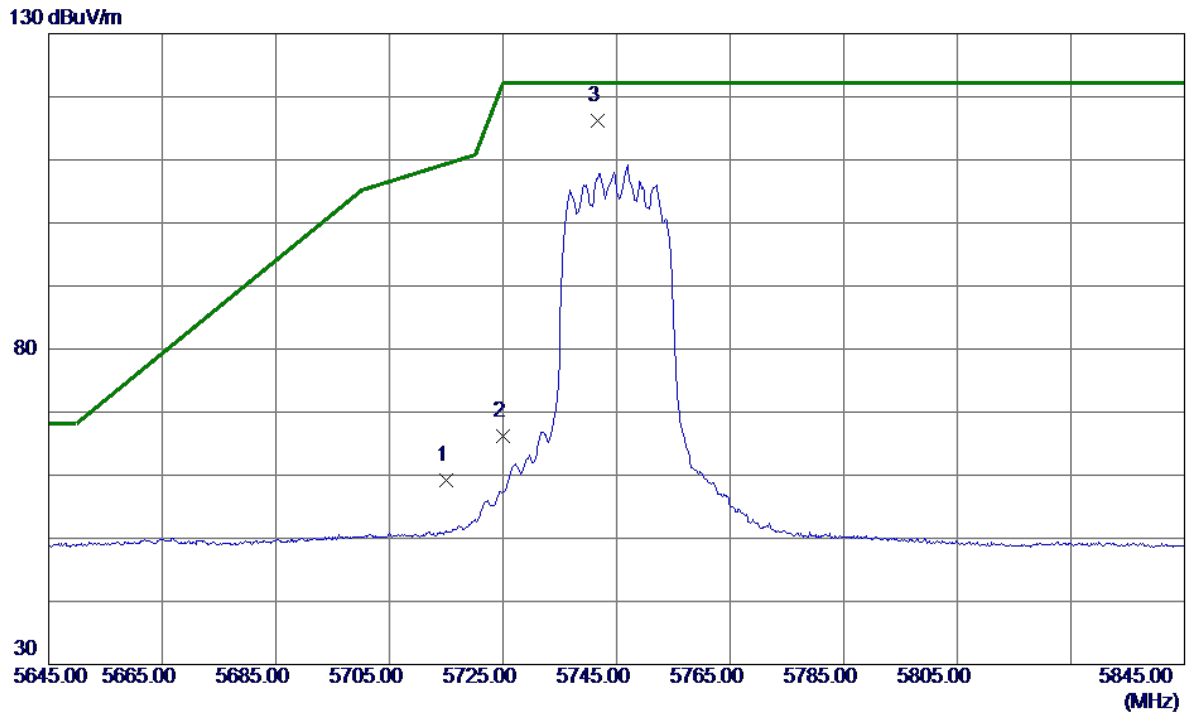

No.	Freq. MHz	Reading Level dBuV/m	Correct Factor dB	Measure ment dBuV/m	Limit dBuV/m	Margin dB	Detector	Comment
1	5715.0000	39.39	19.85	59.24	109.40	-50.16	Peak	
2	5725.0000	46.24	19.88	66.12	122.20	-56.08	Peak	
3 *	5741.7000	96.31	19.93	116.24	122.20	-5.96	Peak	No Limit

REMARKS:

- (1) Measurement Value = Reading Level + Correct Factor.
- (2) Margin Level = Measurement Value - Limit Value.

Test Mode	UNII-3_TX AC(VHT20) Mode 5745 MHz	Polarization	Vertical
-----------	-----------------------------------	--------------	----------

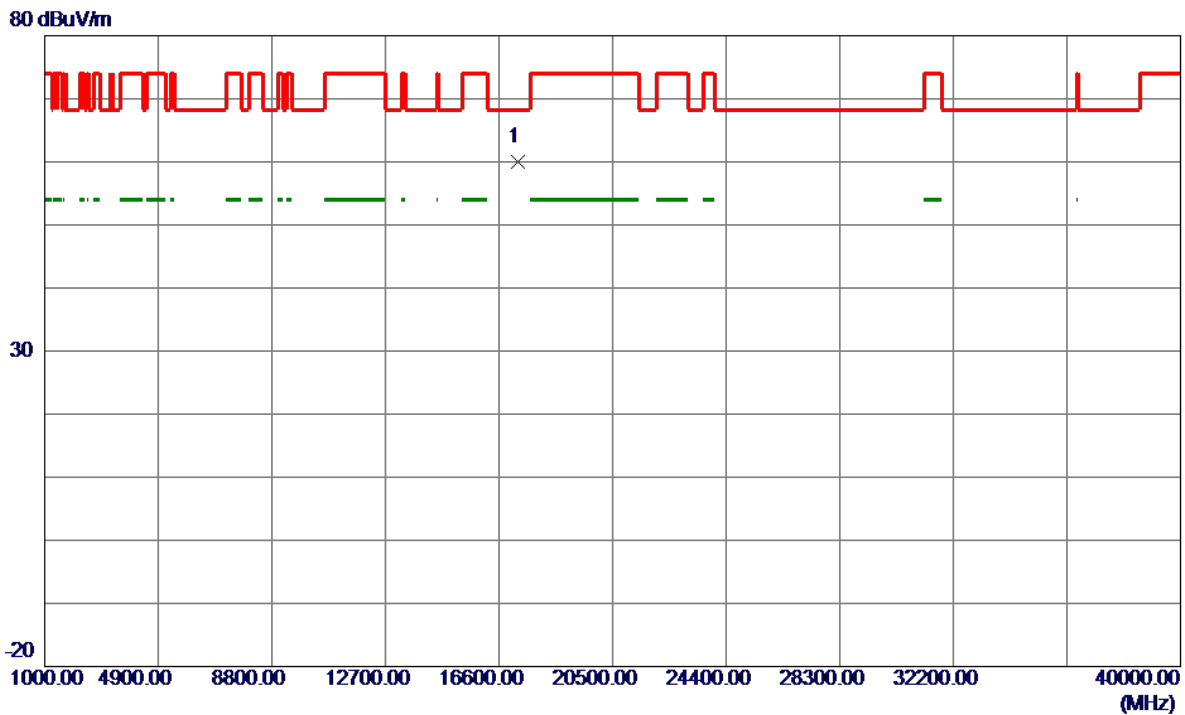

No.	Freq. MHz	Reading Level dBuV/m	Correct Factor dB	Measure ment dBuV/m	Limit dBuV/m	Margin dB	Detector	Comment
1 *	17240.0800	39.54	20.50	60.04	68.20	-8.16	Peak	

**REMARKS:**

- (1) Measurement Value = Reading Level + Correct Factor.
- (2) Margin Level = Measurement Value - Limit Value.

Test Mode	UNII-3_TX AC(VHT20) Mode 5745 MHz	Polarization	Horizontal
-----------	-----------------------------------	--------------	------------

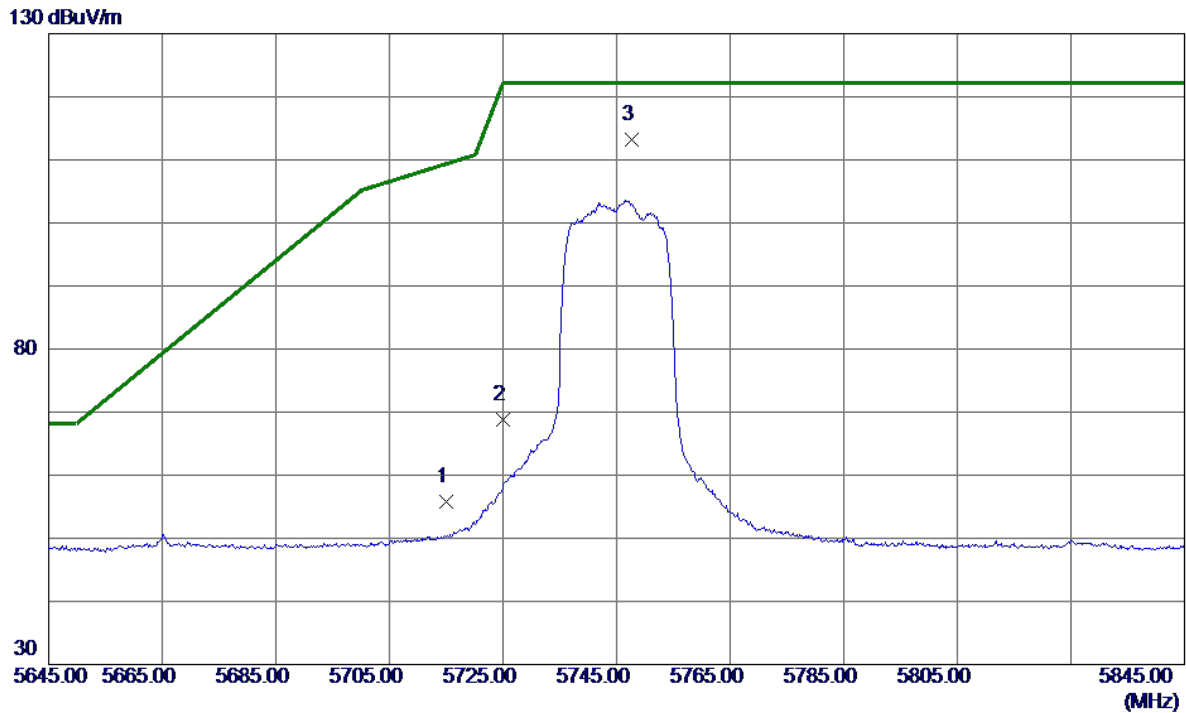

No.	Freq. MHz	Reading Level dBuV/m	Correct Factor dB	Measure ment dBuV/m	Limit dBuV/m	Margin dB	Detector	Comment
1	5715.0000	35.99	19.85	55.84	109.40	-53.56	Peak	
2	5725.0000	48.92	19.88	68.80	122.20	-53.40	Peak	
3 *	5747.6000	93.26	19.94	113.20	122.20	-9.00	Peak	No Limit

**REMARKS:**

- (1) Measurement Value = Reading Level + Correct Factor.
- (2) Margin Level = Measurement Value - Limit Value.

Test Mode	UNII-3_TX AC(VHT20) Mode 5745 MHz	Polarization	Horizontal
-----------	-----------------------------------	--------------	------------

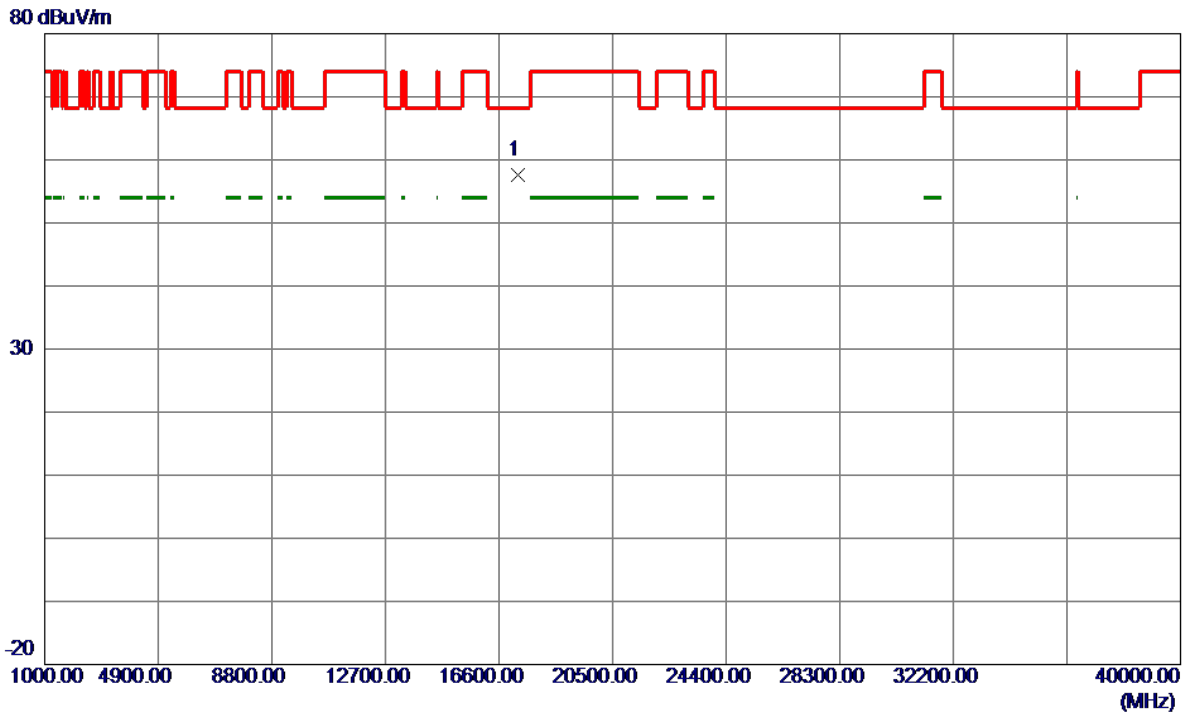

No.	Freq. MHz	Reading Level dBuV/m	Correct Factor dB	Measure ment dBuV/m	Limit dBuV/m	Margin dB	Detector	Comment
1 *	17241.3600	37.03	20.50	57.53	68.20	-10.67	Peak	

**REMARKS:**

- (1) Measurement Value = Reading Level + Correct Factor.
- (2) Margin Level = Measurement Value - Limit Value.

Test Mode	UNII-3_TX AC(VHT20) Mode 5785 MHz	Polarization	Vertical
-----------	-----------------------------------	--------------	----------

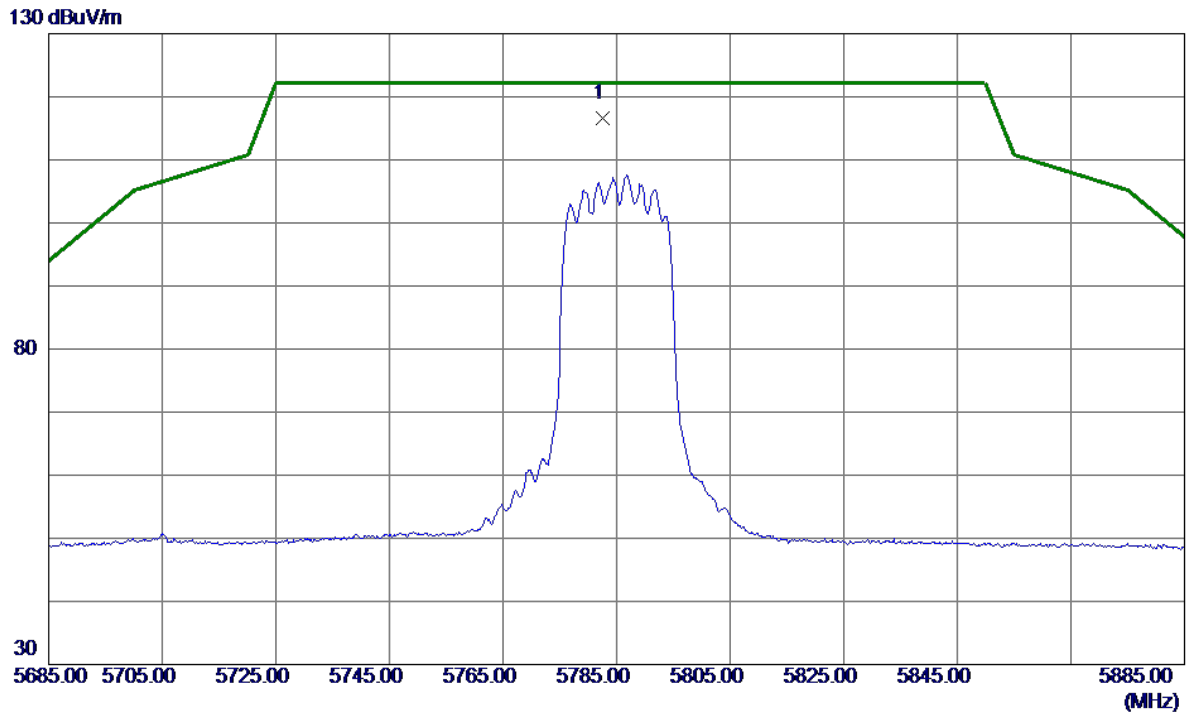

No.	Freq. MHz	Reading Level dBuV/m	Correct Factor dB	Measure ment dBuV/m	Limit dBuV/m	Margin dB	Detector	Comment
1 *	5782.6000	96.59	20.04	116.63	122.20	-5.57	Peak	No Limit

**REMARKS:**

- (1) Measurement Value = Reading Level + Correct Factor.
- (2) Margin Level = Measurement Value - Limit Value.

Test Mode	UNII-3_TX AC(VHT20) Mode 5785 MHz	Polarization	Vertical
-----------	-----------------------------------	--------------	----------

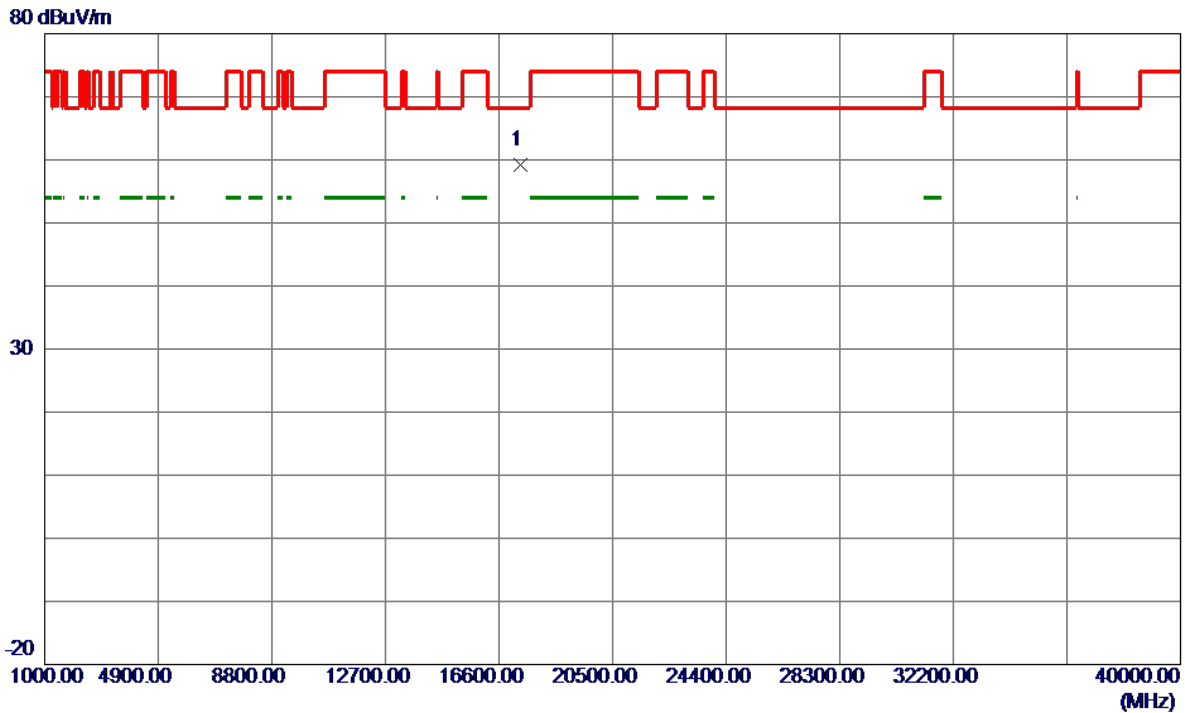

No.	Freq. MHz	Reading Level dBuV/m	Correct Factor dB	Measure ment dBuV/m	Limit dBuV/m	Margin dB	Detector	Comment
1 *	17356.4600	38.21	20.95	59.16	68.20	-9.04	Peak	

REMARKS:

- (1) Measurement Value = Reading Level + Correct Factor.
- (2) Margin Level = Measurement Value - Limit Value.

Test Mode	UNII-3_TX AC(VHT20) Mode 5785 MHz	Polarization	Horizontal
-----------	-----------------------------------	--------------	------------

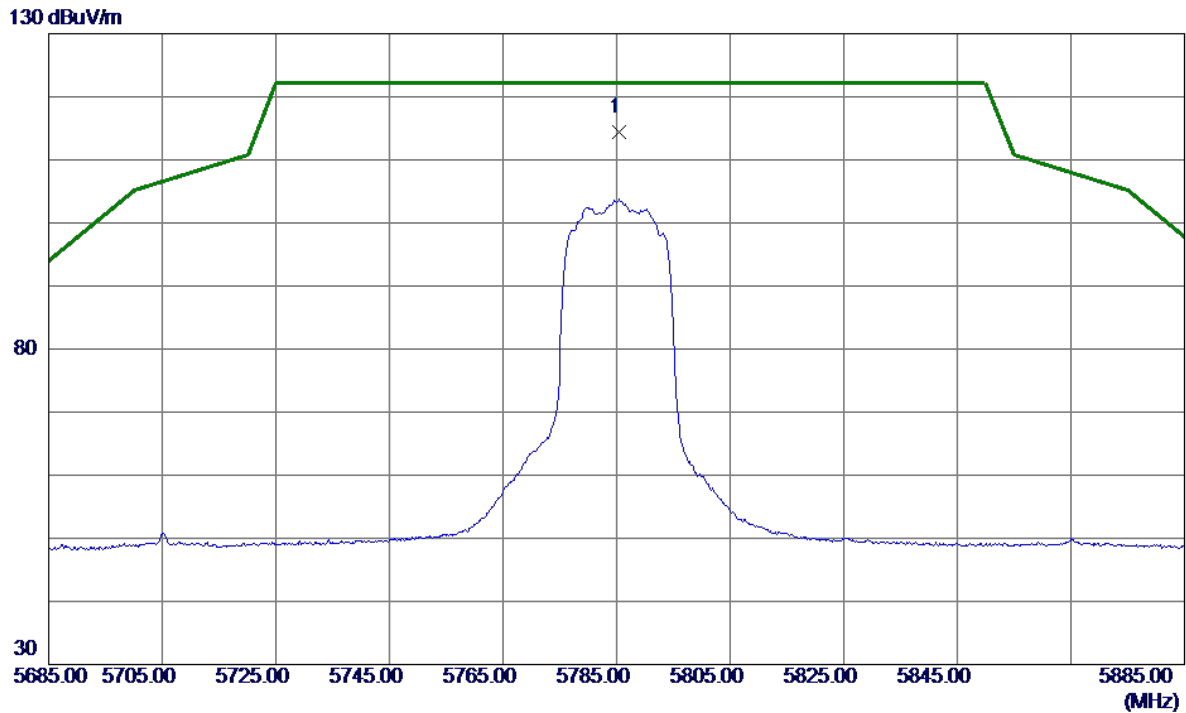

No.	Freq. MHz	Reading Level dBuV/m	Correct Factor dB	Measure ment dBuV/m	Limit dBuV/m	Margin dB	Detector	Comment
1 *	5785.4000	94.26	20.05	114.31	122.20	-7.89	Peak	No Limit

**REMARKS:**

- (1) Measurement Value = Reading Level + Correct Factor.
- (2) Margin Level = Measurement Value - Limit Value.



Test Mode	UNII-3_TX AC(VHT20) Mode 5785 MHz	Polarization	Horizontal
-----------	-----------------------------------	--------------	------------

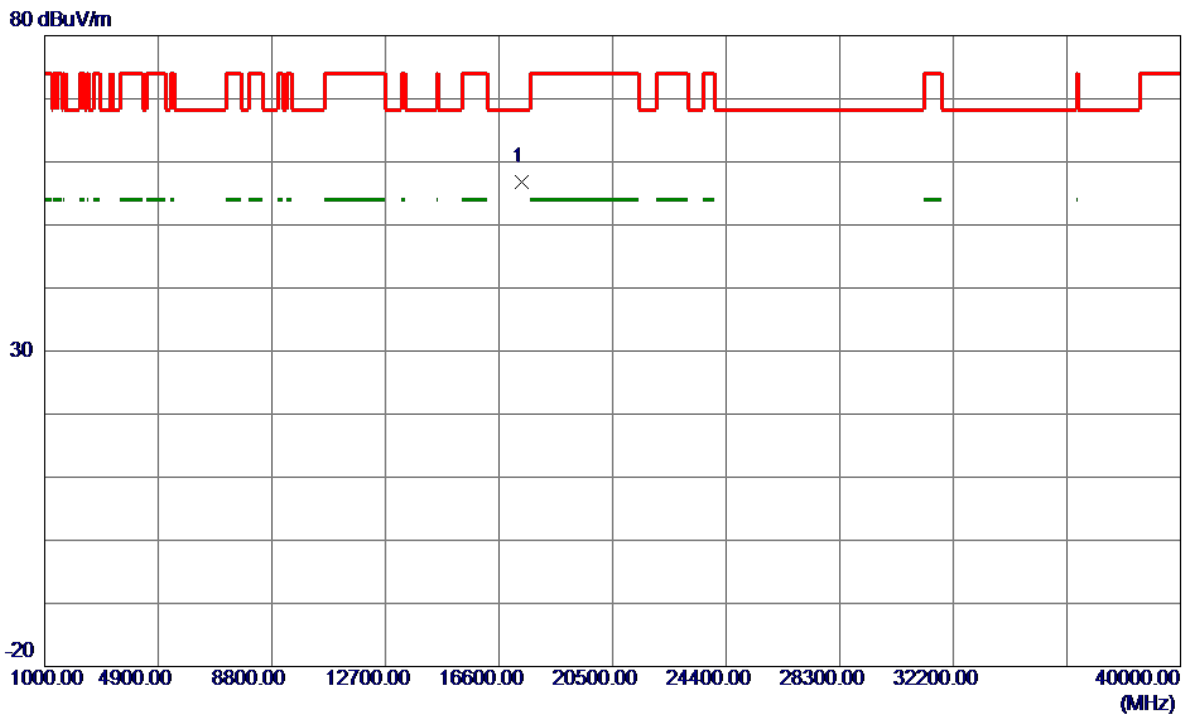

No.	Freq. MHz	Reading Level dBuV/m	Correct Factor dB	Measure ment dBuV/m	Limit dBuV/m	Margin dB	Detector	Comment
1 *	17361.5100	35.85	20.97	56.82	68.20	-11.38	Peak	

**REMARKS:**

- (1) Measurement Value = Reading Level + Correct Factor.
- (2) Margin Level = Measurement Value - Limit Value.

Test Mode	UNII-3_TX AC(VHT20) Mode 5825 MHz	Polarization	Vertical
-----------	-----------------------------------	--------------	----------

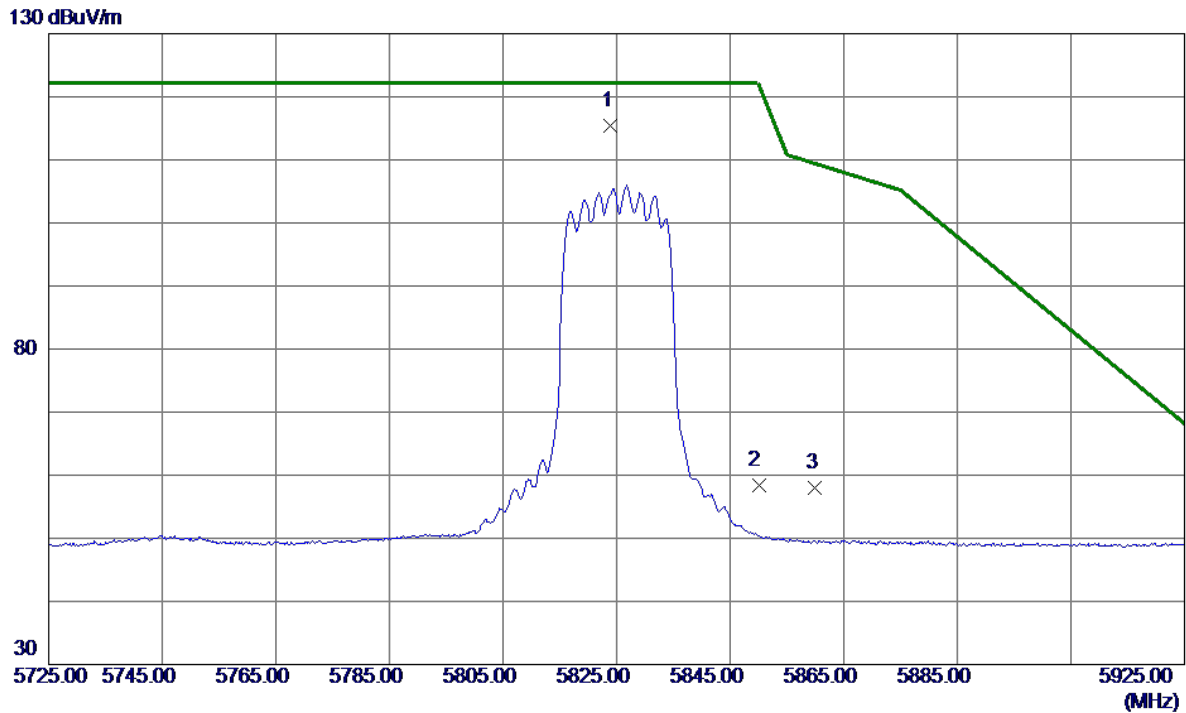

No.	Freq. MHz	Reading Level dBuV/m	Correct Factor dB	Measure ment dBuV/m	Limit dBuV/m	Margin dB	Detector	Comment
1 *	5824.0000	95.28	20.16	115.44	122.20	-6.76	Peak	No Limit
2	5850.0000	38.21	20.23	58.44	122.20	-63.76	Peak	
3	5860.0000	37.75	20.26	58.01	109.40	-51.39	Peak	

**REMARKS:**

- (1) Measurement Value = Reading Level + Correct Factor.
- (2) Margin Level = Measurement Value - Limit Value.

Test Mode	UNII-3_TX AC(VHT20) Mode 5825 MHz	Polarization	Vertical
-----------	-----------------------------------	--------------	----------



No.	Freq. MHz	Reading Level dBuV/m	Correct Factor dB	Measure ment dBuV/m	Limit dBuV/m	Margin dB	Detector	Comment
1 *	17476.9600	39.79	21.41	61.20	68.20	-7.00	Peak	

**REMARKS:**

- (1) Measurement Value = Reading Level + Correct Factor.
- (2) Margin Level = Measurement Value - Limit Value.

Test Mode	UNII-3_TX AC(VHT20) Mode 5825 MHz	Polarization	Horizontal
-----------	-----------------------------------	--------------	------------

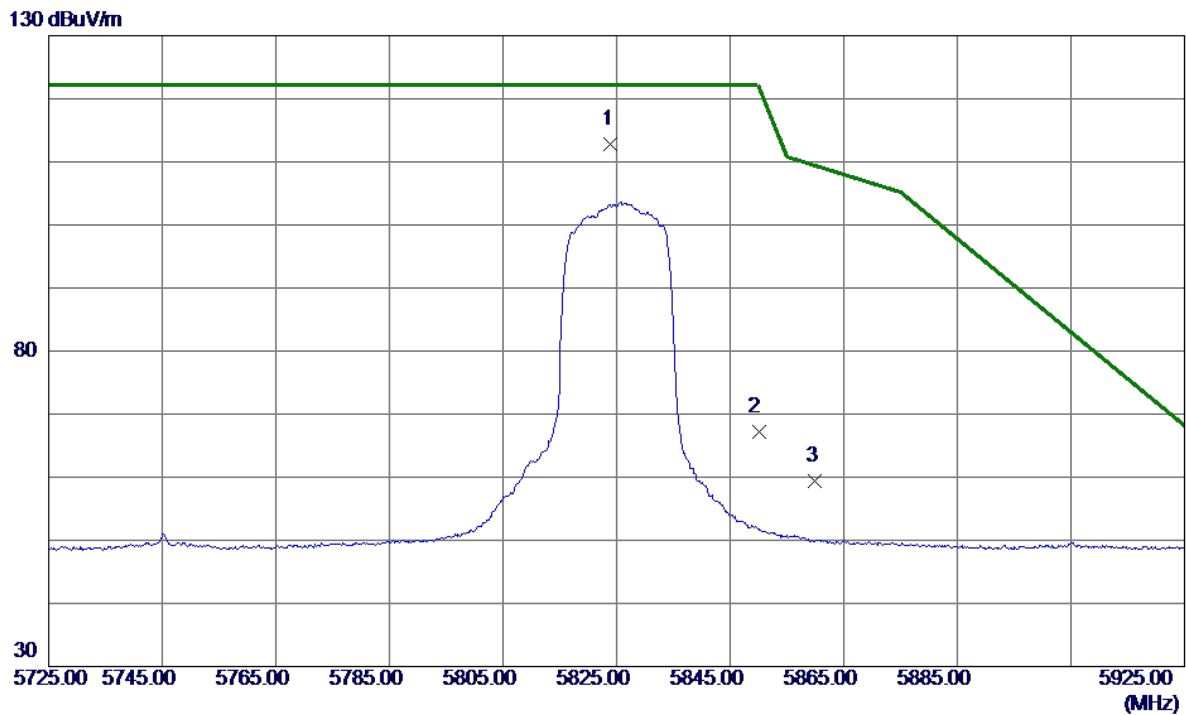

No.	Freq. MHz	Reading Level dBuV/m	Correct Factor dB	Measure ment dBuV/m	Limit dBuV/m	Margin dB	Detector	Comment
1 *	5824.0000	92.58	20.16	112.74	122.20	-9.46	Peak	No Limit
2	5850.0000	47.00	20.23	67.23	122.20	-54.97	Peak	
3	5860.0000	39.17	20.26	59.43	109.40	-49.97	Peak	

**REMARKS:**

- (1) Measurement Value = Reading Level + Correct Factor.
- (2) Margin Level = Measurement Value - Limit Value.

Test Mode	UNII-3_TX AC(VHT20) Mode 5825 MHz	Polarization	Horizontal
-----------	-----------------------------------	--------------	------------

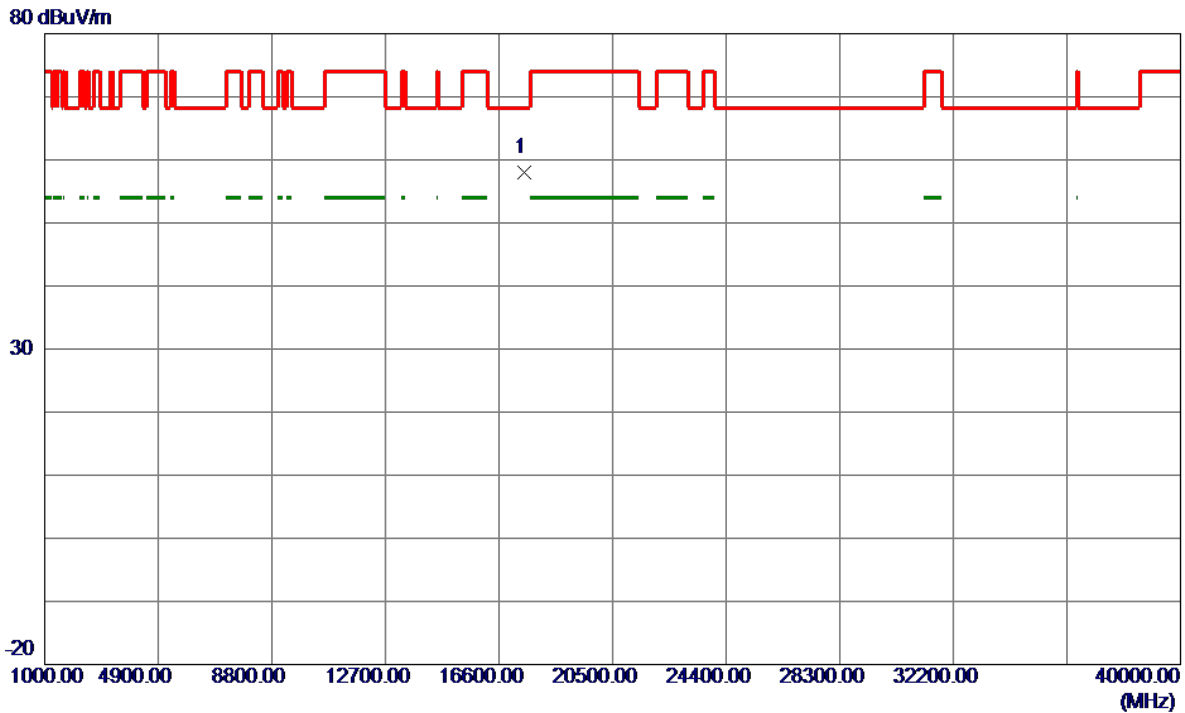

No.	Freq. MHz	Reading Level dBuV/m	Correct Factor dB	Measure ment dBuV/m	Limit dBuV/m	Margin dB	Detector	Comment
1 *	17479.8150	36.54	21.42	57.96	68.20	-10.24	Peak	

**REMARKS:**

- (1) Measurement Value = Reading Level + Correct Factor.
- (2) Margin Level = Measurement Value - Limit Value.

Test Mode	UNII-3_TX AC(VHT40) Mode 5755 MHz	Polarization	Vertical
-----------	-----------------------------------	--------------	----------

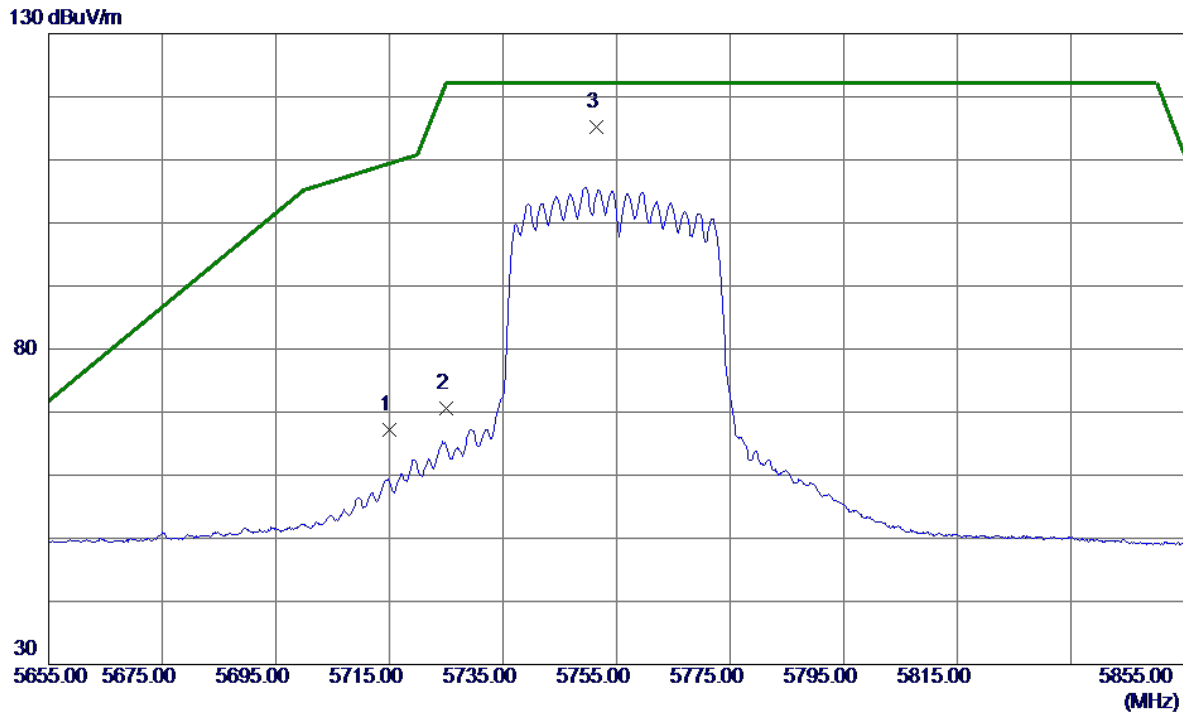

No.	Freq. MHz	Reading Level dBuV/m	Correct Factor dB	Measure ment dBuV/m	Limit dBuV/m	Margin dB	Detector	Comment
1	5715.0000	47.32	19.85	67.17	109.40	-42.23	Peak	
2	5725.0000	50.65	19.88	70.53	122.20	-51.67	Peak	
3 *	5751.5000	95.15	19.96	115.11	122.20	-7.09	Peak	No Limit

**REMARKS:**

- (1) Measurement Value = Reading Level + Correct Factor.
- (2) Margin Level = Measurement Value - Limit Value.

Test Mode	UNII-3_TX AC(VHT40) Mode 5755 MHz	Polarization	Vertical
-----------	-----------------------------------	--------------	----------

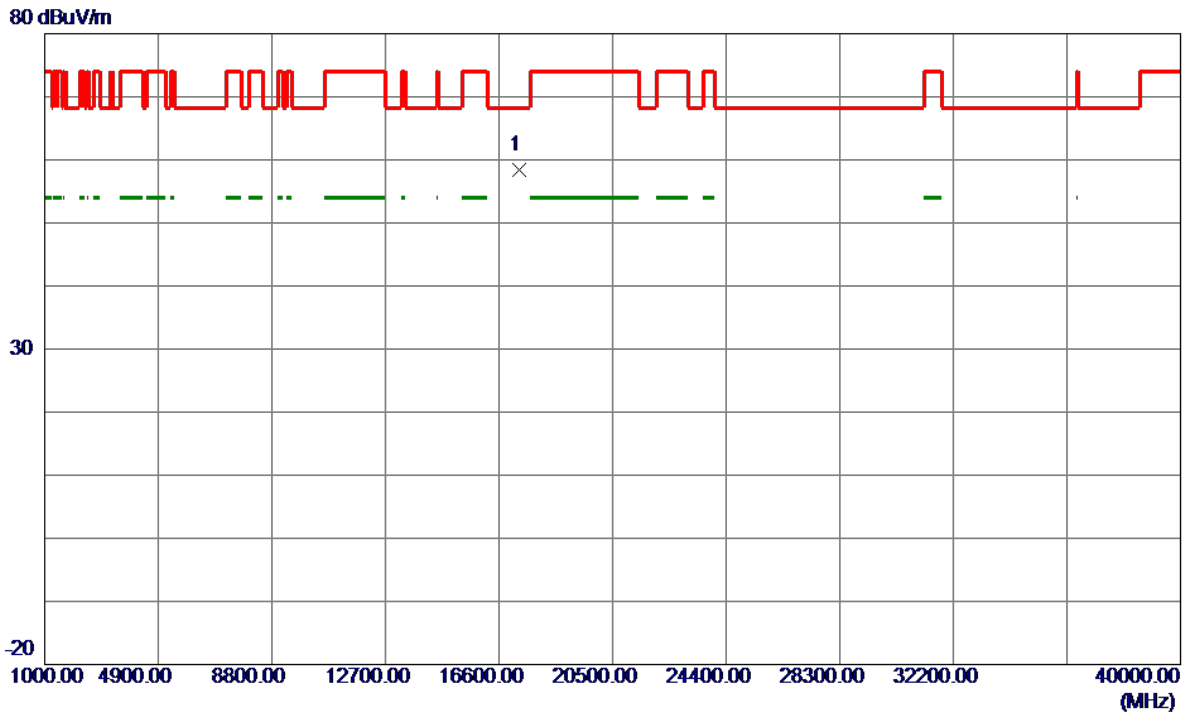

No.	Freq. MHz	Reading Level dBuV/m	Correct Factor dB	Measure ment dBuV/m	Limit dBuV/m	Margin dB	Detector	Comment
1 *	17271.8000	37.78	20.62	58.40	68.20	-9.80	Peak	

**REMARKS:**

- (1) Measurement Value = Reading Level + Correct Factor.
- (2) Margin Level = Measurement Value - Limit Value.

Test Mode	UNII-3_TX AC(VHT40) Mode 5755 MHz	Polarization	Horizontal
-----------	-----------------------------------	--------------	------------

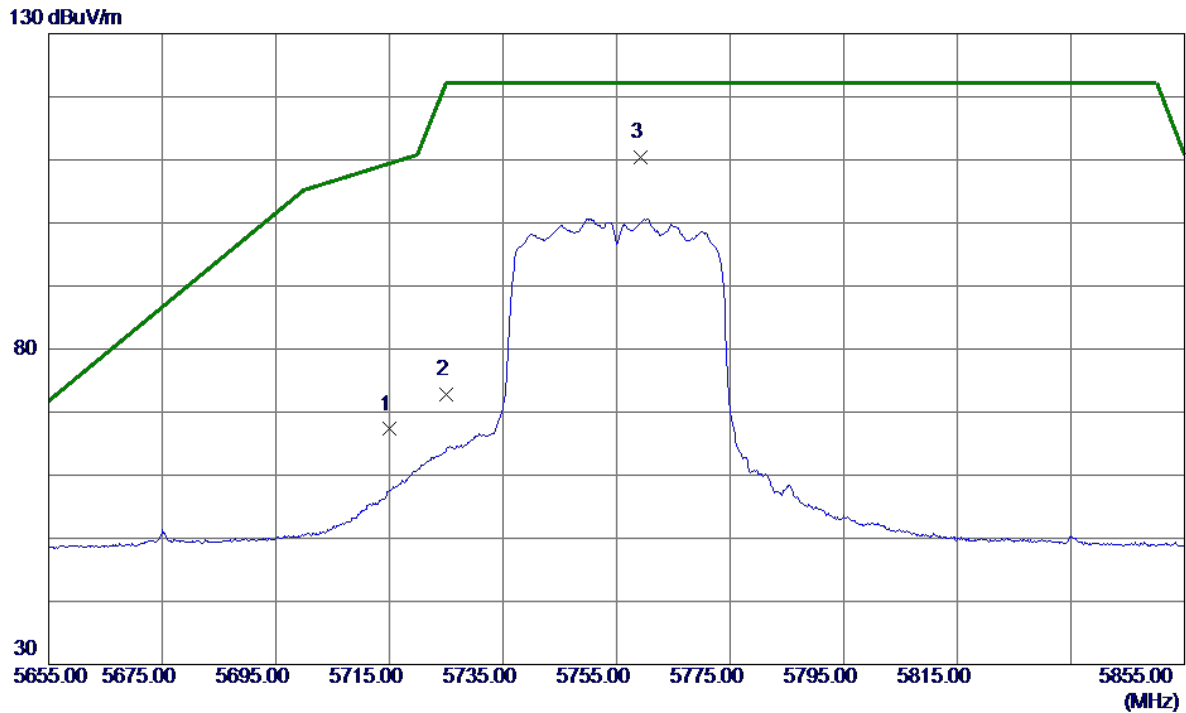

No.	Freq. MHz	Reading Level dBuV/m	Correct Factor dB	Measure ment dBuV/m	Limit dBuV/m	Margin dB	Detector	Comment
1	5715.0000	47.45	19.85	67.30	109.40	-42.10	Peak	
2	5725.0000	52.98	19.88	72.86	122.20	-49.34	Peak	
3 *	5759.2000	90.33	19.98	110.31	122.20	-11.89	Peak	No Limit

**REMARKS:**

- (1) Measurement Value = Reading Level + Correct Factor.
- (2) Margin Level = Measurement Value - Limit Value.



Test Mode	UNII-3_TX AC(VHT40) Mode 5755 MHz	Polarization	Horizontal
-----------	-----------------------------------	--------------	------------

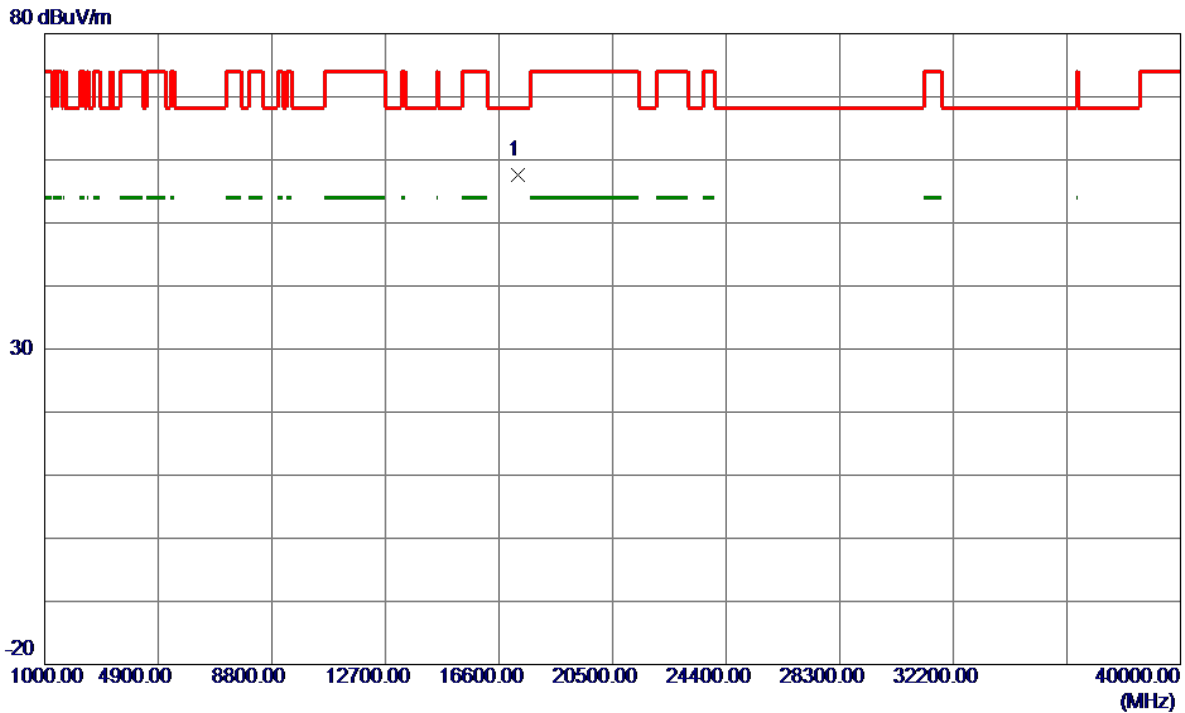

No.	Freq. MHz	Reading Level dBuV/m	Correct Factor dB	Measure ment dBuV/m	Limit dBuV/m	Margin dB	Detector	Comment
1 *	17269.1100	36.93	20.61	57.54	68.20	-10.66	Peak	

**REMARKS:**

- (1) Measurement Value = Reading Level + Correct Factor.
- (2) Margin Level = Measurement Value - Limit Value.

Test Mode	UNII-3_TX AC(VHT40) Mode 5795 MHz	Polarization	Vertical
-----------	-----------------------------------	--------------	----------

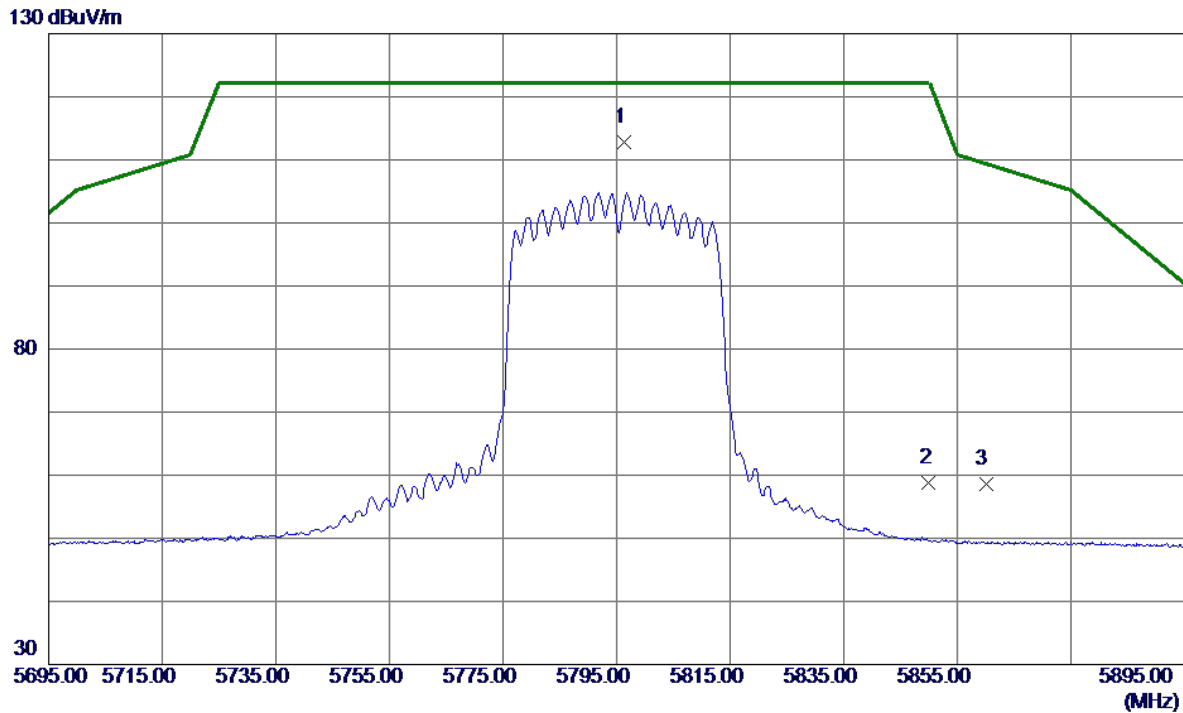

No.	Freq. MHz	Reading Level dBuV/m	Correct Factor dB	Measure ment dBuV/m	Limit dBuV/m	Margin dB	Detector	Comment
1 *	5796.4000	92.73	20.08	112.81	122.20	-9.39	Peak	No Limit
2	5850.0000	38.58	20.23	58.81	122.20	-63.39	Peak	
3	5860.0000	38.29	20.26	58.55	109.40	-50.85	Peak	

**REMARKS:**

- (1) Measurement Value = Reading Level + Correct Factor.
- (2) Margin Level = Measurement Value - Limit Value.

Test Mode	UNII-3_TX AC(VHT40) Mode 5795 MHz	Polarization	Vertical
-----------	-----------------------------------	--------------	----------

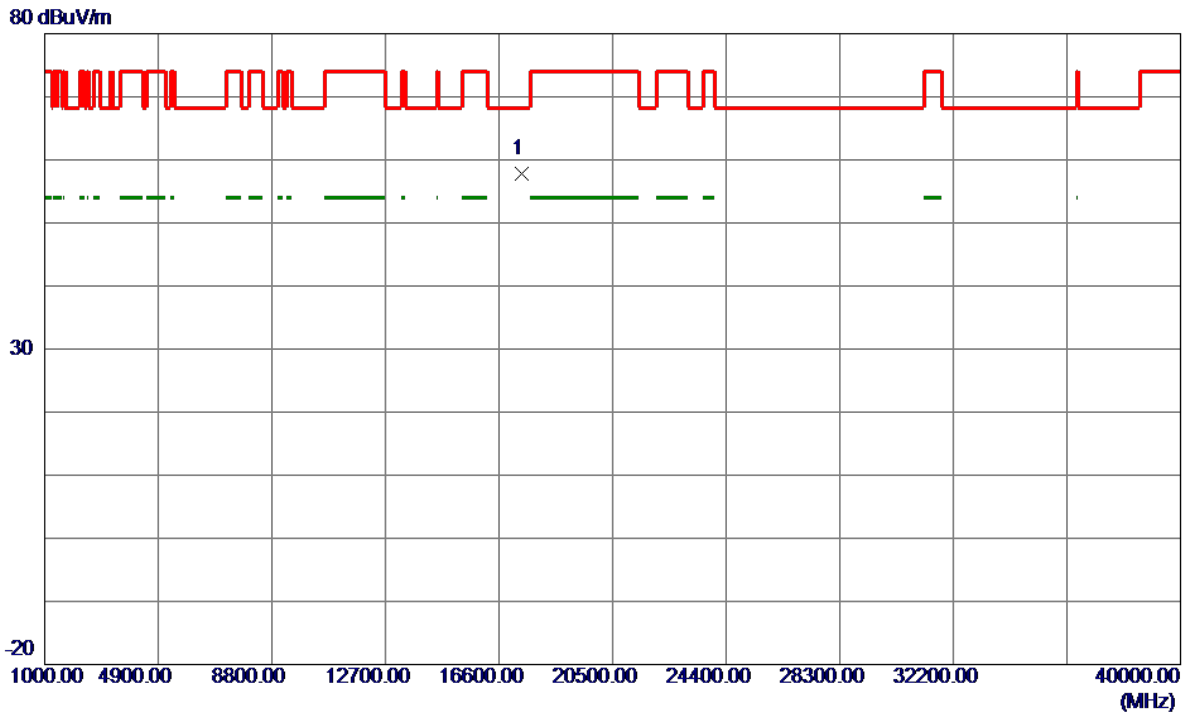

No.	Freq. MHz	Reading Level dBuV/m	Correct Factor dB	Measure ment dBuV/m	Limit dBuV/m	Margin dB	Detector	Comment
1 *	17385.5800	36.75	21.06	57.81	68.20	-10.39	Peak	

**REMARKS:**

- (1) Measurement Value = Reading Level + Correct Factor.
- (2) Margin Level = Measurement Value - Limit Value.

Test Mode	UNII-3_TX AC(VHT40) Mode 5795 MHz	Polarization	Horizontal
-----------	-----------------------------------	--------------	------------

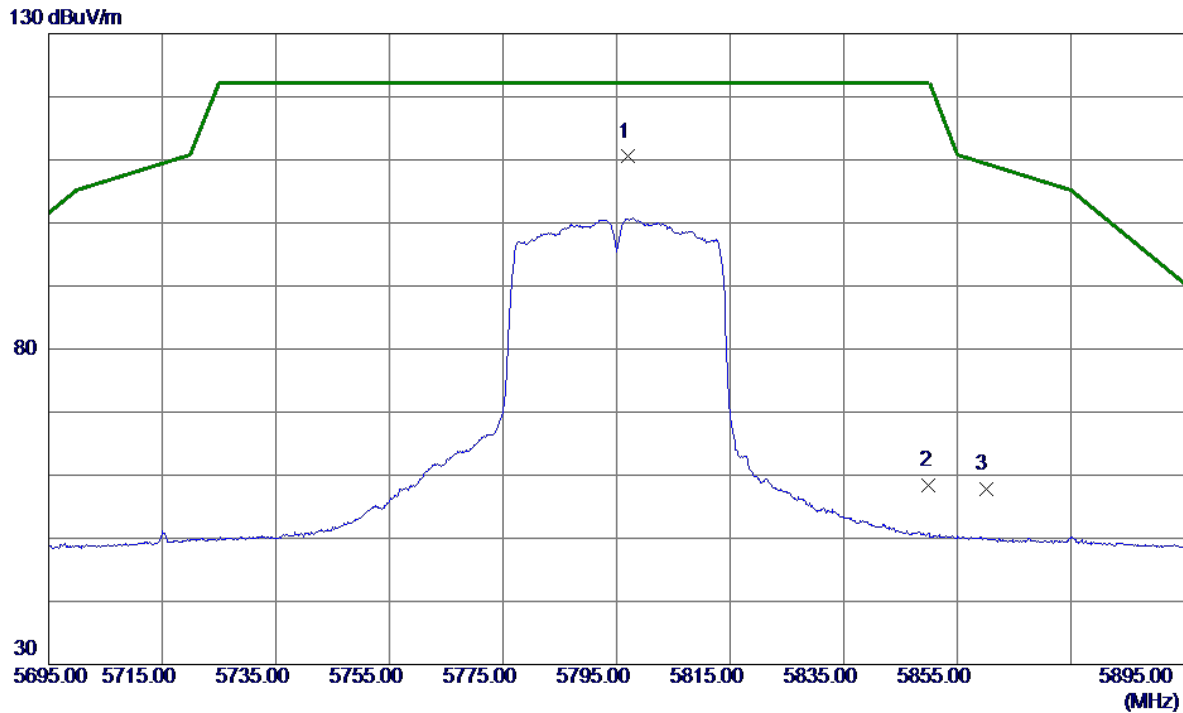

No.	Freq. MHz	Reading Level dBuV/m	Correct Factor dB	Measure ment dBuV/m	Limit dBuV/m	Margin dB	Detector	Comment
1 *	5796.9000	90.42	20.08	110.50	122.20	-11.70	Peak	No Limit
2	5850.0000	38.14	20.23	58.37	122.20	-63.83	Peak	
3	5860.0000	37.58	20.26	57.84	109.40	-51.56	Peak	

**REMARKS:**

- (1) Measurement Value = Reading Level + Correct Factor.
- (2) Margin Level = Measurement Value - Limit Value.

Test Mode	UNII-3_TX AC(VHT40) Mode 5795 MHz	Polarization	Horizontal
-----------	-----------------------------------	--------------	------------

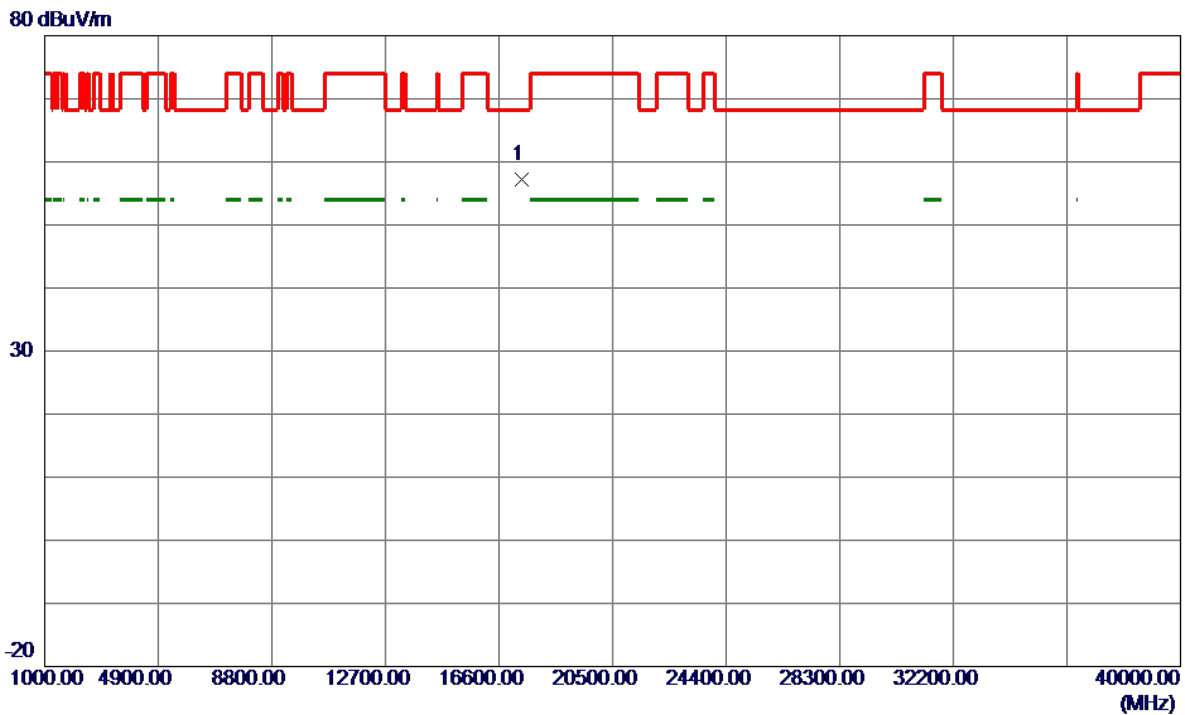

No.	Freq. MHz	Reading Level dBuV/m	Correct Factor dB	Measure ment dBuV/m	Limit dBuV/m	Margin dB	Detector	Comment
1 *	17389.2300	36.15	21.07	57.22	68.20	-10.98	Peak	

**REMARKS:**

- (1) Measurement Value = Reading Level + Correct Factor.
- (2) Margin Level = Measurement Value - Limit Value.

Test Mode	UNII-3_TX AC(VHT80) Mode 5775 MHz	Polarization	Vertical
-----------	-----------------------------------	--------------	----------

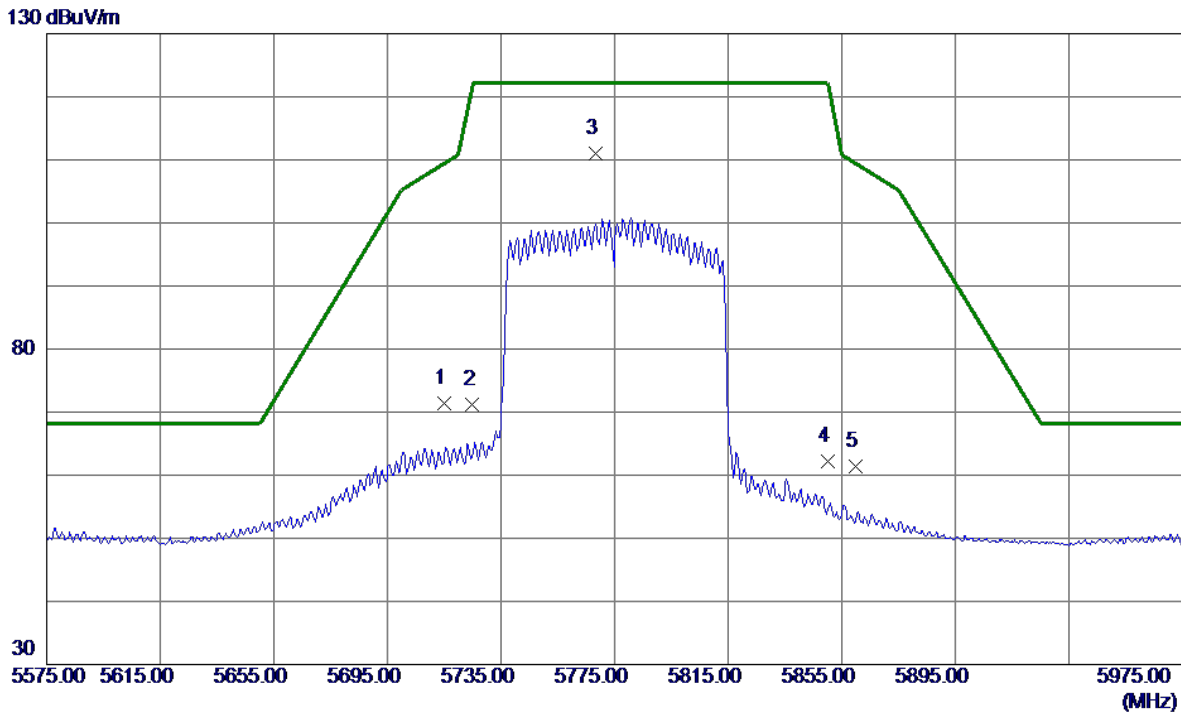

No.	Freq. MHz	Reading Level dBuV/m	Correct Factor dB	Measure ment dBuV/m	Limit dBuV/m	Margin dB	Detector	Comment
1	5715.0000	51.52	19.85	71.37	109.40	-38.03	Peak	
2	5725.0000	51.38	19.88	71.26	122.20	-50.94	Peak	
3 *	5768.2000	91.10	20.00	111.10	122.20	-11.10	Peak	No Limit
4	5850.0000	41.95	20.23	62.18	122.20	-60.02	Peak	
5	5860.0000	41.13	20.26	61.39	109.40	-48.01	Peak	

**REMARKS:**

- (1) Measurement Value = Reading Level + Correct Factor.
- (2) Margin Level = Measurement Value - Limit Value.

Test Mode	UNII-3_TX AC(VHT80) Mode 5775 MHz	Polarization	Vertical
-----------	-----------------------------------	--------------	----------

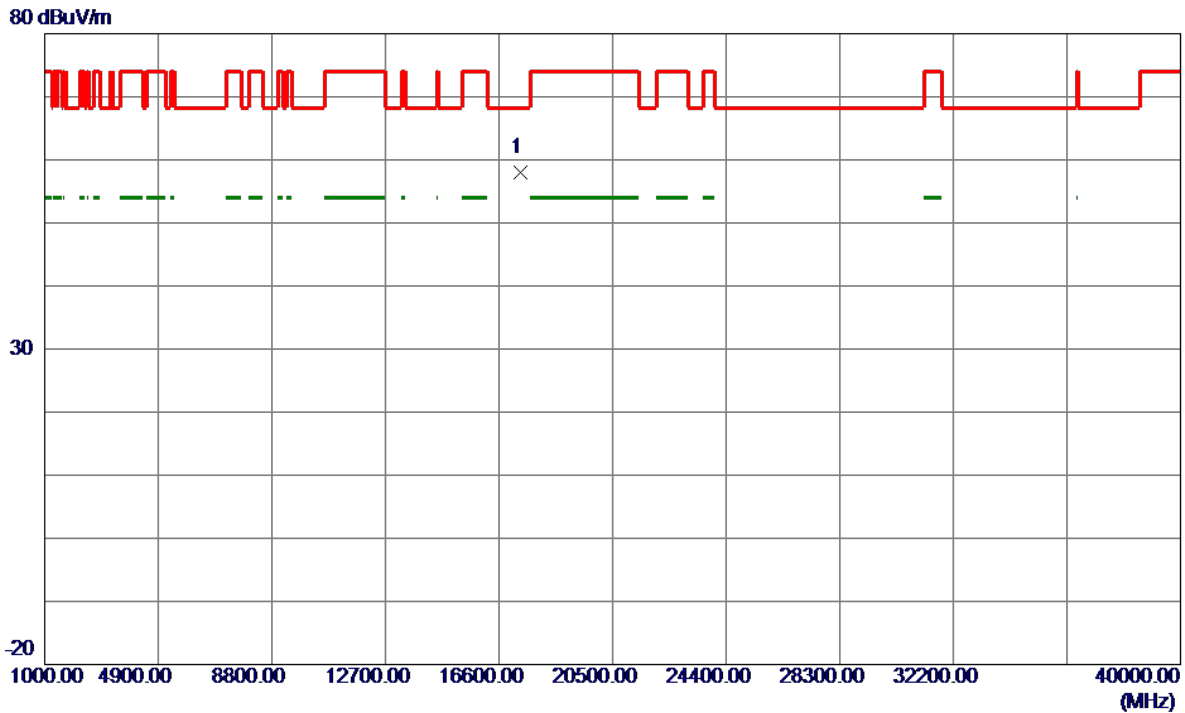

No.	Freq. MHz	Reading Level dBuV/m	Correct Factor dB	Measure ment dBuV/m	Limit dBuV/m	Margin dB	Detector	Comment
1 *	17319.8000	37.20	20.80	58.00	68.20	-10.20	Peak	

**REMARKS:**

- (1) Measurement Value = Reading Level + Correct Factor.
- (2) Margin Level = Measurement Value - Limit Value.

Test Mode	UNII-3_TX AC(VHT80) Mode 5775 MHz	Polarization	Horizontal
-----------	-----------------------------------	--------------	------------

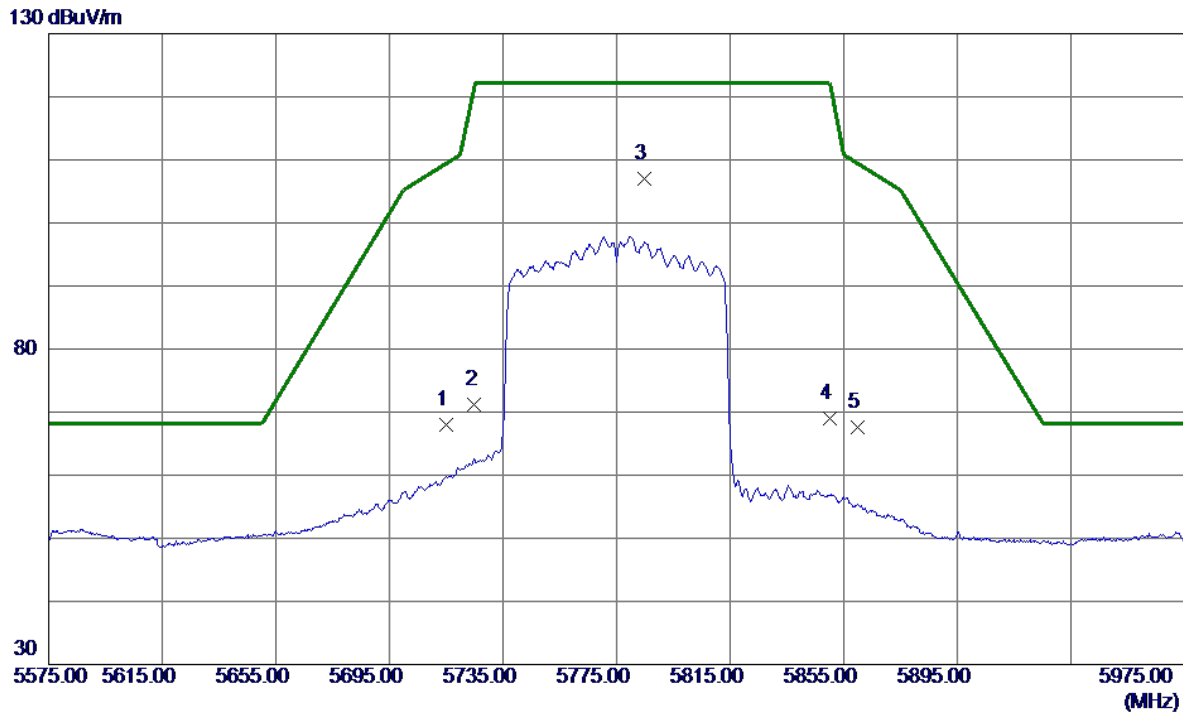

No.	Freq. MHz	Reading Level dBuV/m	Correct Factor dB	Measure ment dBuV/m	Limit dBuV/m	Margin dB	Detector	Comment
1	5715.0000	48.19	19.85	68.04	109.40	-41.36	Peak	
2	5725.0000	51.35	19.88	71.23	122.20	-50.97	Peak	
3 *	5784.8000	86.86	20.05	106.91	122.20	-15.29	Peak	No Limit
4	5850.0000	48.69	20.23	68.92	122.20	-53.28	Peak	
5	5860.0000	47.35	20.26	67.61	109.40	-41.79	Peak	

**REMARKS:**

- (1) Measurement Value = Reading Level + Correct Factor.
- (2) Margin Level = Measurement Value - Limit Value.



Test Mode	UNII-3_TX AC(VHT80) Mode 5775 MHz	Polarization	Horizontal
-----------	-----------------------------------	--------------	------------

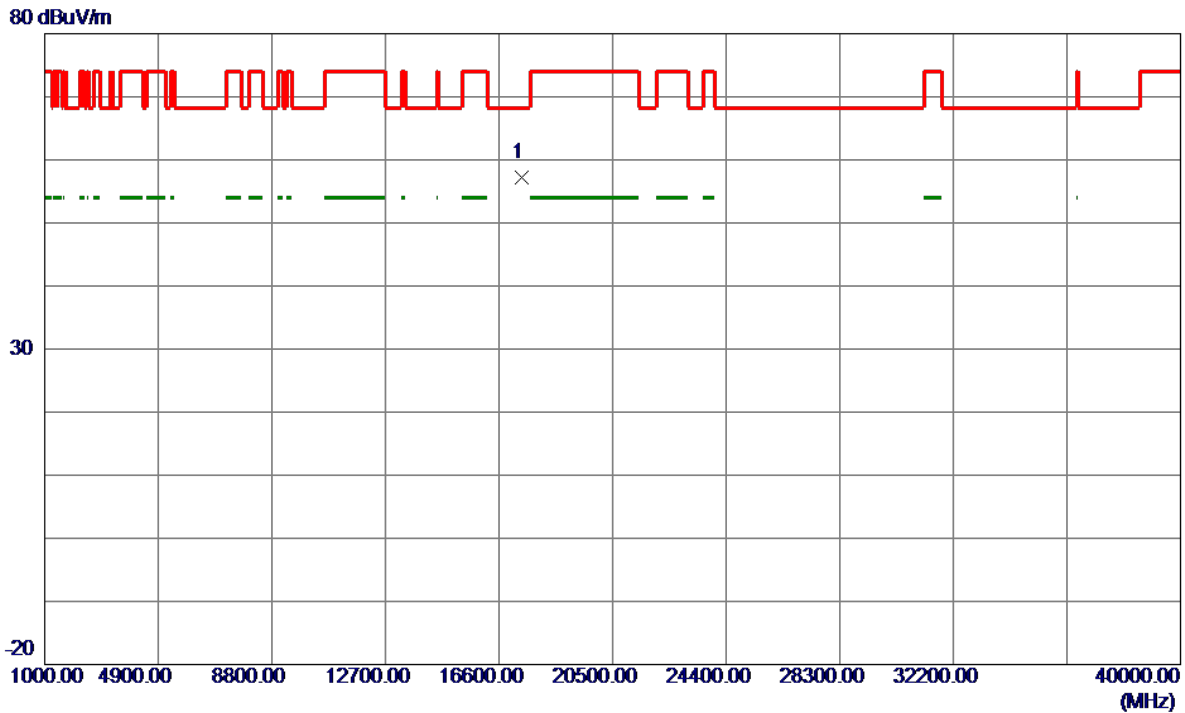

No.	Freq. MHz	Reading Level dBuV/m	Correct Factor dB	Measure ment dBuV/m	Limit dBuV/m	Margin dB	Detector	Comment
1 *	17383.0650	36.15	21.05	57.20	68.20	-11.00	Peak	

**REMARKS:**

- (1) Measurement Value = Reading Level + Correct Factor.
- (2) Margin Level = Measurement Value - Limit Value.

## **APPENDIX E - BANDWIDTH**

Test Mode	UNII-1_TX A Mode
-----------	------------------

Channel	Frequency (MHz)	26 dB Bandwidth (MHz)	99 % Occupied Bandwidth (MHz)
36	5180	20.587	16.800
40	5200	23.389	16.800
48	5240	24.789	16.800

### CH36

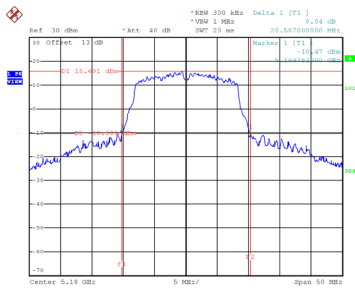

Date: 20\_JAN\_2022 00:19:55

### CH40 26 dB Bandwidth

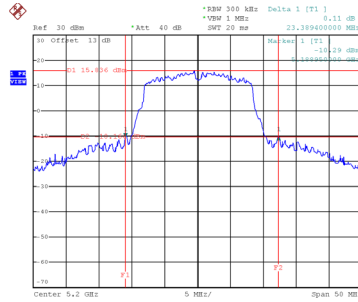

Date: 20\_JAN\_2022 00:20:53

### CH48

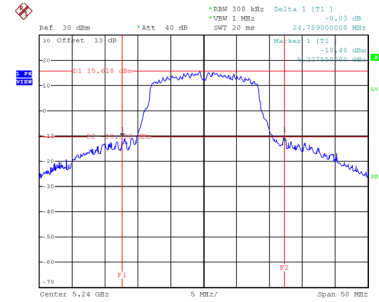

Date: 20\_JAN\_2022 00:22:07

### 99 % Occupied Bandwidth

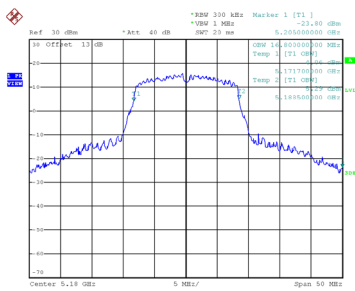

Date: 20\_JAN\_2022 00:19:50

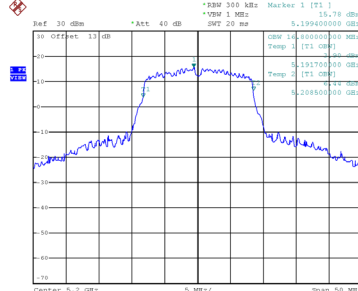

Date: 20\_JAN\_2022 00:20:35

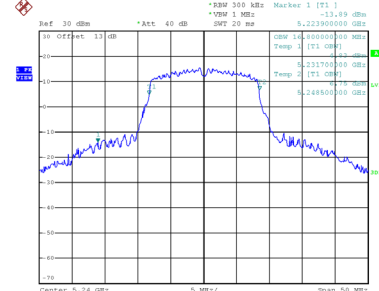

Date: 20\_JAN\_2022 00:21:48

Test Mode	UNII-1_TX AC(VHT20) Mode
-----------	--------------------------

Channel	Frequency (MHz)	26 dB Bandwidth (MHz)	99 % Occupied Bandwidth (MHz)
36	5180	20.490	18.100
40	5200	20.650	18.100
48	5240	20.650	18.200

### CH36

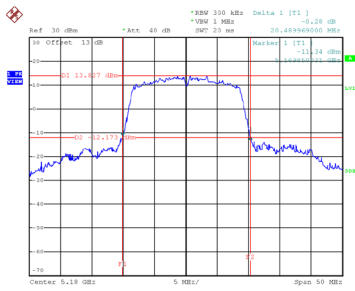

Date: 12.FEB.2022 11:25:19

### CH40 26 dB Bandwidth

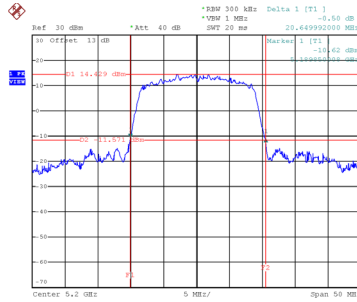

Date: 25.JAN.2022 11:38:38

### CH48

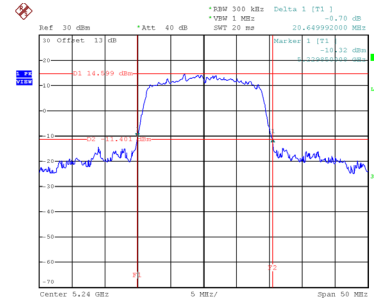

Date: 25.JAN.2022 11:41:13

### 99 % Occupied Bandwidth

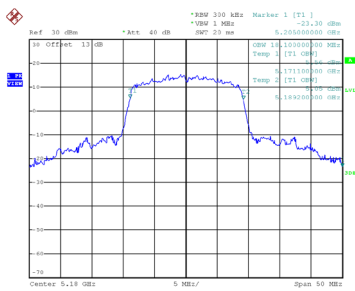

Date: 20.JAN.2022 00:12:52

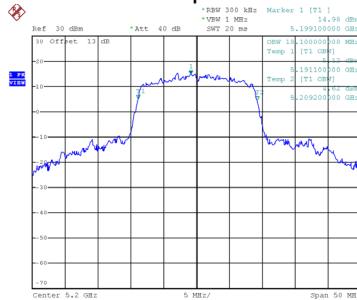

Date: 20.JAN.2022 00:13:55

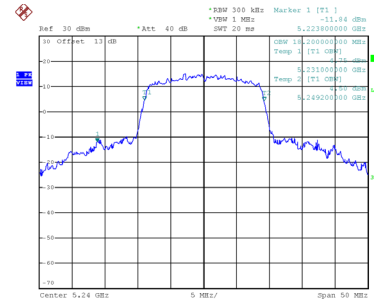

Date: 20.JAN.2022 00:14:42

Test Mode	UNII-1_TX AC(VHT40) Mode
-----------	--------------------------

Channel	Frequency (MHz)	26 dB Bandwidth (MHz)	99 % Occupied Bandwidth (MHz)
38	5190	40.388	37.000
46	5230	40.900	37.400

### CH38

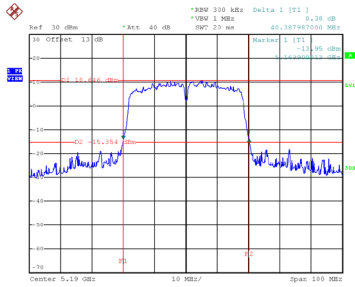

### CH46 26 dB Bandwidth

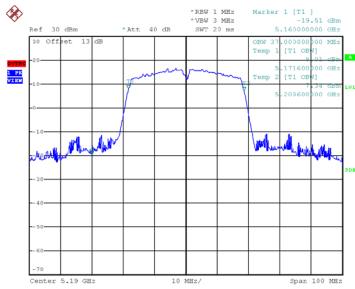
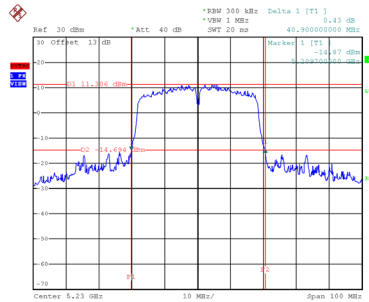

### 99 % Occupied Bandwidth

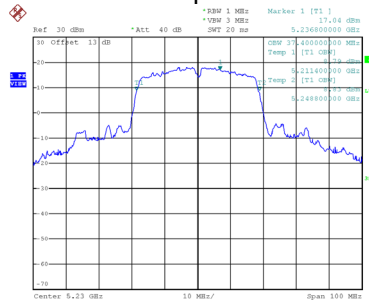

Test Mode	UNII-1_TX AC(VHT80) Mode
-----------	--------------------------

Channel	Frequency (MHz)	26 dB Bandwidth (MHz)	99 % Occupied Bandwidth (MHz)
42	5210	81.600	75.600

### CH42 26 dB Bandwidth

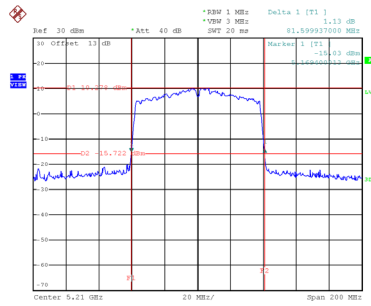

Date: 20.JAN.2022 00:10:31

### 99 % Occupied Bandwidth

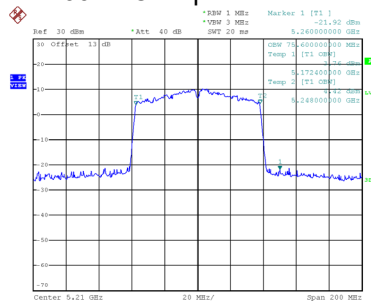

Date: 20.JAN.2022 00:10:07

Test Mode	UNII-3_TX A Mode
-----------	------------------

Channel	Frequency (MHz)	6 dB Bandwidth (MHz)	99 % Occupied Bandwidth (MHz)	6 dB Bandwidth Min. Limit (MHz)	Result
149	5745	15.199	16.900	0.5	Complies
157	5785	15.200	16.900	0.5	Complies
165	5825	15.300	16.800	0.5	Complies

**CH149**

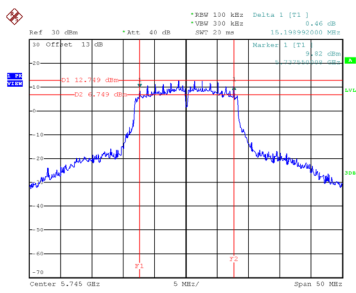

Date: 20\_JAN\_2022 00:23:04

**CH157**

**6 dB Bandwidth**

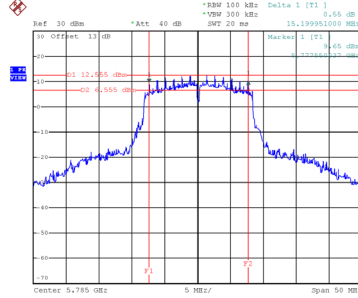

Date: 20\_JAN\_2022 00:24:01

**CH165**

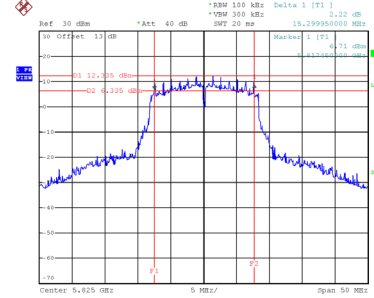

Date: 20\_JAN\_2022 00:24:52

**99 % Occupied Bandwidth**

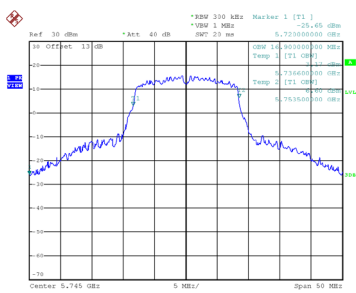

Date: 20\_JAN\_2022 00:22:41

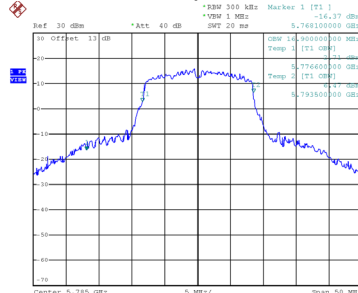

Date: 20\_JAN\_2022 00:23:36

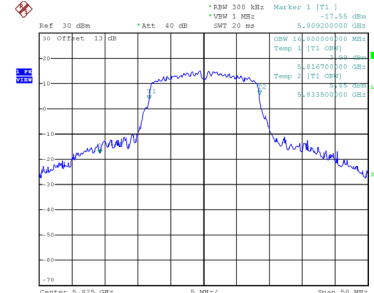

Date: 20\_JAN\_2022 00:24:30

Test Mode UNII-3\_TX AC(VHT20) Mode

Channel	Frequency (MHz)	6 dB Bandwidth (MHz)	99 % Occupied Bandwidth (MHz)	6 dB Bandwidth Min. Limit (MHz)	Result
149	5745	15.208	18.200	0.5	Complies
157	5785	15.200	18.300	0.5	Complies
165	5825	15.090	18.200	0.5	Complies

**CH149**

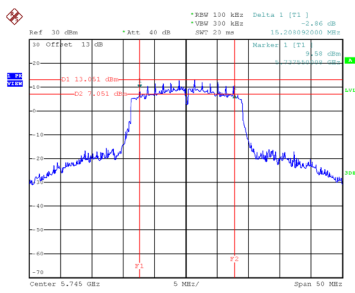

Date: 20.JAN.2022 00:15:56

**CH157**

**6 dB Bandwidth**

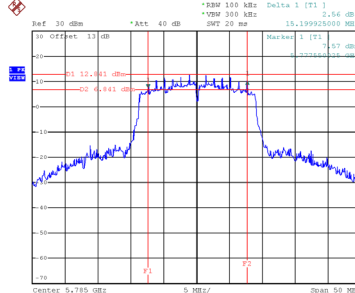

Date: 20.JAN.2022 00:16:45

**CH165**

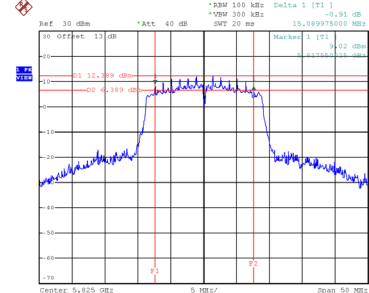

Date: 20.JAN.2022 00:17:57

**99 % Occupied Bandwidth**

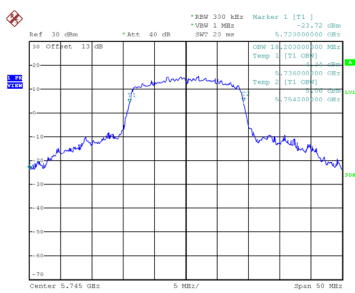

Date: 20.JAN.2022 00:15:33

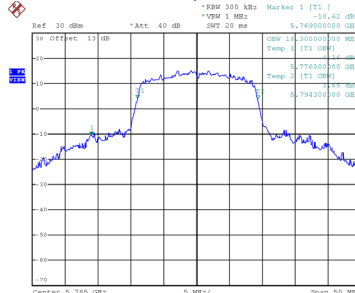

Date: 20.JAN.2022 00:16:21

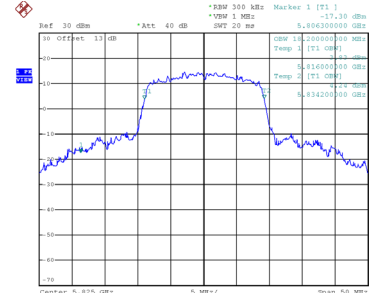

Date: 20.JAN.2022 00:17:33



Test Mode UNII-3\_TX AC(VHT40) Mode

Channel	Frequency (MHz)	6 dB Bandwidth (MHz)	99 % Occupied Bandwidth (MHz)	6 dB Bandwidth Min. Limit (MHz)	Result
151	5755	34.200	38.000	0.5	Complies
159	5795	35.300	38.200	0.5	Complies

**CH151**

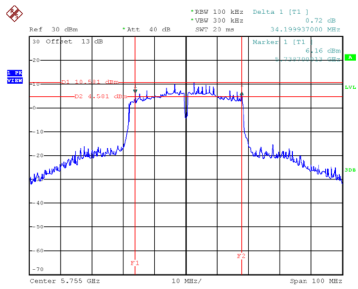

Date: 20\_JAN\_2022 00:07:58

**CH159  
6 dB Bandwidth**

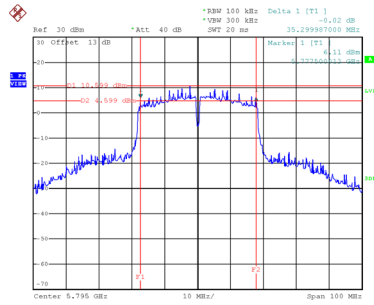

Date: 20\_JAN\_2022 00:08:51

**99 % Occupied Bandwidth**

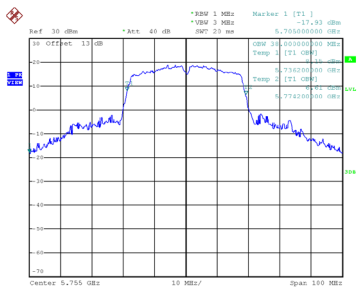

Date: 20\_JAN\_2022 00:07:29

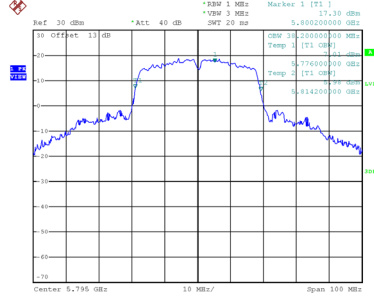

Date: 20\_JAN\_2022 00:08:23

Test Mode	UNII-3_TX AC(VHT80) Mode
-----------	--------------------------

Channel	Frequency (MHz)	6 dB Bandwidth (MHz)	99 % Occupied Bandwidth (MHz)	6 dB Bandwidth Min. Limit (MHz)	Result
155	5775	75.400	80.400	0.5	Complies

### CH155 6 dB Bandwidth

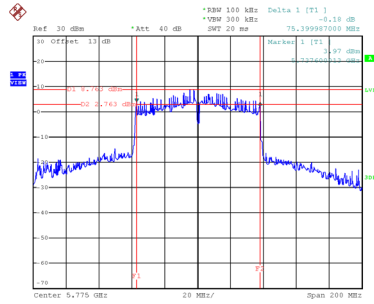

Date: 20.JAN.2022 00:11:23

### 99 % Occupied Bandwidth

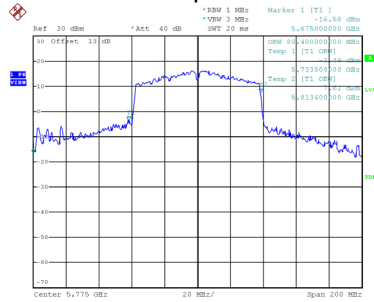

Date: 20.JAN.2022 00:10:56

## **APPENDIX F - MAXIMUM OUTPUT POWER**

**Non Beamforming**

Test Mode	UNII-1_TX A Mode_Ant. 1
-----------	-------------------------

Channel	Frequency (MHz)	Output Power (dBm)	Duty Factor	Output Power + Duty Factor (dBm)	Max. Limit (dBm)	Max. Limit (W)	Result
36	5180	20.12	0.18	20.30	30.00	1.0000	Complies
40	5200	19.74	0.18	19.92	30.00	1.0000	Complies
48	5240	18.94	0.18	19.12	30.00	1.0000	Complies

Test Mode	UNII-1_TX A Mode_Ant. 2
-----------	-------------------------

Channel	Frequency (MHz)	Output Power (dBm)	Duty Factor	Output Power + Duty Factor (dBm)	Max. Limit (dBm)	Max. Limit (W)	Result
36	5180	20.03	0.18	20.21	30.00	1.0000	Complies
40	5200	19.35	0.18	19.53	30.00	1.0000	Complies
48	5240	18.80	0.18	18.98	30.00	1.0000	Complies

Test Mode	UNII-1_TX A Mode_Total
-----------	------------------------

Channel	Frequency (MHz)	Output Power (dBm)	Max. Limit (dBm)	Max. Limit (W)	Result
36	5180	23.26	30.00	1.0000	Complies
40	5200	22.74	30.00	1.0000	Complies
48	5240	22.06	30.00	1.0000	Complies

Test Mode	UNII-1_TX AC(VHT20) Mode_Ant. 1
-----------	---------------------------------

Channel	Frequency (MHz)	Output Power (dBm)	Duty Factor	Output Power + Duty Factor (dBm)	Max. Limit (dBm)	Max. Limit (W)	Result
36	5180	19.92	0.20	20.12	30.00	1.0000	Complies
40	5200	20.31	0.20	20.51	30.00	1.0000	Complies
48	5240	20.30	0.20	20.50	30.00	1.0000	Complies

Test Mode	UNII-1_TX AC(VHT20) Mode_Ant. 2
-----------	---------------------------------

Channel	Frequency (MHz)	Output Power (dBm)	Duty Factor	Output Power + Duty Factor (dBm)	Max. Limit (dBm)	Max. Limit (W)	Result
36	5180	19.84	0.20	20.04	30.00	1.0000	Complies
40	5200	20.38	0.20	20.58	30.00	1.0000	Complies
48	5240	20.48	0.20	20.68	30.00	1.0000	Complies

Test Mode	UNII-1_TX AC(VHT20) Mode_Total
-----------	--------------------------------

Channel	Frequency (MHz)	Output Power (dBm)	Max. Limit (dBm)	Max. Limit (W)	Result
36	5180	23.09	30.00	1.0000	Complies
40	5200	23.56	30.00	1.0000	Complies
48	5240	23.60	30.00	1.0000	Complies

Test Mode	UNII-1_TX AC(VHT40) Mode_Ant. 1
-----------	---------------------------------

Channel	Frequency (MHz)	Output Power (dBm)	Duty Factor	Output Power + Duty Factor (dBm)	Max. Limit (dBm)	Max. Limit (W)	Result
38	5190	12.85	0.18	13.03	30.00	1.0000	Complies
46	5230	18.42	0.18	18.60	30.00	1.0000	Complies

Test Mode	UNII-1_TX AC(VHT40) Mode_Ant. 2
-----------	---------------------------------

Channel	Frequency (MHz)	Output Power (dBm)	Duty Factor	Output Power + Duty Factor (dBm)	Max. Limit (dBm)	Max. Limit (W)	Result
38	5190	12.77	0.18	12.95	30.00	1.0000	Complies
46	5230	18.35	0.18	18.53	30.00	1.0000	Complies

Test Mode	UNII-1_TX AC(VHT40) Mode_Total
-----------	--------------------------------

Channel	Frequency (MHz)	Output Power (dBm)	Max. Limit (dBm)	Max. Limit (W)	Result
38	5190	16.00	30.00	1.0000	Complies
46	5230	21.57	30.00	1.0000	Complies

Test Mode	UNII-1_TX AC(VHT80) Mode_Ant. 1
-----------	---------------------------------

Channel	Frequency (MHz)	Output Power (dBm)	Duty Factor	Output Power + Duty Factor (dBm)	Max. Limit (dBm)	Max. Limit (W)	Result
42	5210	11.56	0.42	11.98	30.00	1.0000	Complies

Test Mode	UNII-1_TX AC(VHT80) Mode_Ant. 2
-----------	---------------------------------

Channel	Frequency (MHz)	Output Power (dBm)	Duty Factor	Output Power + Duty Factor (dBm)	Max. Limit (dBm)	Max. Limit (W)	Result
42	5210	11.62	0.42	12.04	30.00	1.0000	Complies

Test Mode	UNII-1_TX AC(VHT80) Mode_Total
-----------	--------------------------------

Channel	Frequency (MHz)	Output Power (dBm)	Max. Limit (dBm)	Max. Limit (W)	Result
42	5210	15.02	30.00	1.0000	Complies

Test Mode	UNII-3_TX A Mode_Ant. 1
-----------	-------------------------

Channel	Frequency (MHz)	Output Power (dBm)	Duty Factor	Output Power + Duty Factor (dBm)	Max. Limit (dBm)	Max. Limit (W)	Result
149	5745	20.15	0.18	20.33	30.00	1.0000	Complies
157	5785	20.05	0.18	20.23	30.00	1.0000	Complies
165	5825	20.26	0.18	20.44	30.00	1.0000	Complies

Test Mode	UNII-3_TX A Mode_Ant. 2
-----------	-------------------------

Channel	Frequency (MHz)	Output Power (dBm)	Duty Factor	Output Power + Duty Factor (dBm)	Max. Limit (dBm)	Max. Limit (W)	Result
149	5745	19.98	0.18	20.16	30.00	1.0000	Complies
157	5785	20.08	0.18	20.26	30.00	1.0000	Complies
165	5825	20.04	0.18	20.22	30.00	1.0000	Complies

Test Mode	UNII-3_TX A Mode_Total
-----------	------------------------

Channel	Frequency (MHz)	Output Power (dBm)	Max. Limit (dBm)	Max. Limit (W)	Result
149	5745	23.25	30.00	1.0000	Complies
157	5785	23.25	30.00	1.0000	Complies
165	5825	23.34	30.00	1.0000	Complies



Test Mode	UNII-3_TX AC(VHT20) Mode_Ant. 1
-----------	---------------------------------

Channel	Frequency (MHz)	Output Power (dBm)	Duty Factor	Output Power + Duty Factor (dBm)	Max. Limit (dBm)	Max. Limit (W)	Result
149	5745	19.91	0.20	20.11	30.00	1.0000	Complies
157	5785	19.94	0.20	20.14	30.00	1.0000	Complies
165	5825	19.91	0.20	20.11	30.00	1.0000	Complies

Test Mode	UNII-3_TX AC(VHT20) Mode_Ant. 2
-----------	---------------------------------

Channel	Frequency (MHz)	Output Power (dBm)	Duty Factor	Output Power + Duty Factor (dBm)	Max. Limit (dBm)	Max. Limit (W)	Result
149	5745	20.17	0.20	20.37	30.00	1.0000	Complies
157	5785	20.16	0.20	20.36	30.00	1.0000	Complies
165	5825	19.92	0.20	20.12	30.00	1.0000	Complies

Test Mode	UNII-3_TX AC(VHT20) Mode_Total
-----------	--------------------------------

Channel	Frequency (MHz)	Output Power (dBm)	Max. Limit (dBm)	Max. Limit (W)	Result
149	5745	23.26	30.00	1.0000	Complies
157	5785	23.26	30.00	1.0000	Complies
165	5825	23.13	30.00	1.0000	Complies

Test Mode	UNII-3_TX AC(VHT40) Mode_Ant. 1
-----------	---------------------------------

Channel	Frequency (MHz)	Output Power (dBm)	Duty Factor	Output Power + Duty Factor (dBm)	Max. Limit (dBm)	Max. Limit (W)	Result
151	5755	20.19	0.18	20.37	30.00	1.0000	Complies
159	5795	20.15	0.18	20.33	30.00	1.0000	Complies

Test Mode	UNII-3_TX AC(VHT40) Mode_Ant. 2
-----------	---------------------------------

Channel	Frequency (MHz)	Output Power (dBm)	Duty Factor	Output Power + Duty Factor (dBm)	Max. Limit (dBm)	Max. Limit (W)	Result
151	5755	20.14	0.18	20.32	30.00	1.0000	Complies
159	5795	20.13	0.18	20.31	30.00	1.0000	Complies

Test Mode	UNII-3_TX AC(VHT40) Mode_Total
-----------	--------------------------------

Channel	Frequency (MHz)	Output Power (dBm)	Max. Limit (dBm)	Max. Limit (W)	Result
151	5755	23.35	30.00	1.0000	Complies
159	5795	23.33	30.00	1.0000	Complies

Test Mode	UNII-3_TX AC(VHT80) Mode_Ant. 1
-----------	---------------------------------

Channel	Frequency (MHz)	Output Power (dBm)	Duty Factor	Output Power + Duty Factor (dBm)	Max. Limit (dBm)	Max. Limit (W)	Result
155	5775	20.14	0.42	20.56	30.00	1.0000	Complies

Test Mode	UNII-3_TX AC(VHT80) Mode_Ant. 2
-----------	---------------------------------

Channel	Frequency (MHz)	Output Power (dBm)	Duty Factor	Output Power + Duty Factor (dBm)	Max. Limit (dBm)	Max. Limit (W)	Result
155	5775	20.20	0.42	20.62	30.00	1.0000	Complies

Test Mode	UNII-3_TX AC(VHT80) Mode_Total
-----------	--------------------------------

Channel	Frequency (MHz)	Output Power (dBm)	Max. Limit (dBm)	Max. Limit (W)	Result
155	5775	23.60	30.00	1.0000	Complies

### Beamforming

<b>Test Mode</b>	UNII-1_TX AC(VHT20) Mode_Ant. 1
------------------	---------------------------------

Channel	Frequency (MHz)	Output Power (dBm)	Duty Factor	Output Power + Duty Factor (dBm)	Max. Limit (dBm)	Max. Limit (W)	Result
36	5180	19.48	0.20	19.68	30.00	1.0000	Complies
40	5200	19.75	0.20	19.95	30.00	1.0000	Complies
48	5240	19.87	0.20	20.07	30.00	1.0000	Complies

<b>Test Mode</b>	UNII-1_TX AC(VHT20) Mode_Ant. 2
------------------	---------------------------------

Channel	Frequency (MHz)	Output Power (dBm)	Duty Factor	Output Power + Duty Factor (dBm)	Max. Limit (dBm)	Max. Limit (W)	Result
36	5180	19.34	0.20	19.54	30.00	1.0000	Complies
40	5200	19.62	0.20	19.82	30.00	1.0000	Complies
48	5240	20.06	0.20	20.26	30.00	1.0000	Complies

<b>Test Mode</b>	UNII-1_TX AC(VHT20) Mode_Total
------------------	--------------------------------

Channel	Frequency (MHz)	Output Power (dBm)	Max. Limit (dBm)	Max. Limit (W)	Result
36	5180	22.62	30.00	1.0000	Complies
40	5200	22.90	30.00	1.0000	Complies
48	5240	23.18	30.00	1.0000	Complies

Test Mode	UNII-1_TX AC(VHT40) Mode_Ant. 1
-----------	---------------------------------

Channel	Frequency (MHz)	Output Power (dBm)	Duty Factor	Output Power + Duty Factor (dBm)	Max. Limit (dBm)	Max. Limit (W)	Result
38	5190	12.01	0.18	12.19	30.00	1.0000	Complies
46	5230	17.88	0.18	18.06	30.00	1.0000	Complies

Test Mode	UNII-1_TX AC(VHT40) Mode_Ant. 2
-----------	---------------------------------

Channel	Frequency (MHz)	Output Power (dBm)	Duty Factor	Output Power + Duty Factor (dBm)	Max. Limit (dBm)	Max. Limit (W)	Result
38	5190	11.94	0.18	12.12	30.00	1.0000	Complies
46	5230	17.76	0.18	17.94	30.00	1.0000	Complies

Test Mode	UNII-1_TX AC(VHT40) Mode_Total
-----------	--------------------------------

Channel	Frequency (MHz)	Output Power (dBm)	Max. Limit (dBm)	Max. Limit (W)	Result
38	5190	15.16	30.00	1.0000	Complies
46	5230	21.01	30.00	1.0000	Complies

Test Mode	UNII-1_TX AC(VHT80) Mode_Ant. 1
-----------	---------------------------------

Channel	Frequency (MHz)	Output Power (dBm)	Duty Factor	Output Power + Duty Factor (dBm)	Max. Limit (dBm)	Max. Limit (W)	Result
42	5210	10.94	0.42	11.36	30.00	1.0000	Complies

Test Mode	UNII-1_TX AC(VHT80) Mode_Ant. 2
-----------	---------------------------------

Channel	Frequency (MHz)	Output Power (dBm)	Duty Factor	Output Power + Duty Factor (dBm)	Max. Limit (dBm)	Max. Limit (W)	Result
42	5210	11.04	0.42	11.46	30.00	1.0000	Complies

Test Mode	UNII-1_TX AC(VHT80) Mode_Total
-----------	--------------------------------

Channel	Frequency (MHz)	Output Power (dBm)	Max. Limit (dBm)	Max. Limit (W)	Result
42	5210	14.42	30.00	1.0000	Complies

Test Mode	UNII-3_TX AC(VHT20) Mode_Ant. 1
-----------	---------------------------------

Channel	Frequency (MHz)	Output Power (dBm)	Duty Factor	Output Power + Duty Factor (dBm)	Max. Limit (dBm)	Max. Limit (W)	Result
149	5745	19.53	0.20	19.73	30.00	1.0000	Complies
157	5785	19.47	0.20	19.67	30.00	1.0000	Complies
165	5825	19.45	0.20	19.65	30.00	1.0000	Complies

Test Mode	UNII-3_TX AC(VHT20) Mode_Ant. 2
-----------	---------------------------------

Channel	Frequency (MHz)	Output Power (dBm)	Duty Factor	Output Power + Duty Factor (dBm)	Max. Limit (dBm)	Max. Limit (W)	Result
149	5745	19.68	0.20	19.88	30.00	1.0000	Complies
157	5785	19.58	0.20	19.78	30.00	1.0000	Complies
165	5825	19.55	0.20	19.75	30.00	1.0000	Complies

Test Mode	UNII-3_TX AC(VHT20) Mode_Total
-----------	--------------------------------

Channel	Frequency (MHz)	Output Power (dBm)	Max. Limit (dBm)	Max. Limit (W)	Result
149	5745	22.82	30.00	1.0000	Complies
157	5785	22.74	30.00	1.0000	Complies
165	5825	22.71	30.00	1.0000	Complies

Test Mode	UNII-3_TX AC(VHT40) Mode_Ant. 1
-----------	---------------------------------

Channel	Frequency (MHz)	Output Power (dBm)	Duty Factor	Output Power + Duty Factor (dBm)	Max. Limit (dBm)	Max. Limit (W)	Result
151	5755	19.71	0.18	19.89	30.00	1.0000	Complies
159	5795	19.63	0.18	19.81	30.00	1.0000	Complies

Test Mode	UNII-3_TX AC(VHT40) Mode_Ant. 2
-----------	---------------------------------

Channel	Frequency (MHz)	Output Power (dBm)	Duty Factor	Output Power + Duty Factor (dBm)	Max. Limit (dBm)	Max. Limit (W)	Result
151	5755	19.64	0.18	19.82	30.00	1.0000	Complies
159	5795	19.57	0.18	19.75	30.00	1.0000	Complies

Test Mode	UNII-3_TX AC(VHT40) Mode_Total
-----------	--------------------------------

Channel	Frequency (MHz)	Output Power (dBm)	Max. Limit (dBm)	Max. Limit (W)	Result
151	5755	22.86	30.00	1.0000	Complies
159	5795	22.79	30.00	1.0000	Complies



Test Mode	UNII-3_TX AC(VHT80) Mode_Ant. 1
-----------	---------------------------------

Channel	Frequency (MHz)	Output Power (dBm)	Duty Factor	Output Power + Duty Factor (dBm)	Max. Limit (dBm)	Max. Limit (W)	Result
155	5775	19.62	0.42	20.04	30.00	1.0000	Complies

Test Mode	UNII-3_TX AC(VHT80) Mode_Ant. 2
-----------	---------------------------------

Channel	Frequency (MHz)	Output Power (dBm)	Duty Factor	Output Power + Duty Factor (dBm)	Max. Limit (dBm)	Max. Limit (W)	Result
155	5775	19.69	0.42	20.11	30.00	1.0000	Complies

Test Mode	UNII-3_TX AC(VHT80) Mode_Total
-----------	--------------------------------

Channel	Frequency (MHz)	Output Power (dBm)	Max. Limit (dBm)	Max. Limit (W)	Result
155	5775	23.09	30.00	1.0000	Complies

## **APPENDIX G - POWER SPECTRAL DENSITY**