

FCC Radio Test Report

FCC ID: 2AXJ4T2E

This report concerns: Original Grant

Project No. : 2012C099
Equipment : AC600 Wireless Dual Band PCI Express Adapter
Brand Name : tp-link
Test Model : Archer T2E
Series Model : N/A
Applicant : TP-Link Corporation Limited
Address : Room 901, 9/F. , New East Ocean Centre, 9 Science Museum Road, Tsim Sha Tsui, Kowloon, Hong Kong
Manufacturer : TP-Link Corporation Limited
Address : Room 901, 9/F. , New East Ocean Centre, 9 Science Museum Road, Tsim Sha Tsui, Kowloon, Hong Kong
Date of Receipt : Dec. 26, 2020
Date of Test : Dec. 28, 2020 ~ Feb. 08, 2021
Issued Date : Mar. 03, 2021
Report Version : R01
Test Sample : Engineering Sample No.:DG2028121656 for radiated, DG2028121658 for conducted.
Standard(s) : FCC CFR Title 47, Part 15, Subpart E
ANSI C63.10-2013
FCC KDB 789033 D02 General UNII Test Procedures New Rules v02r01
FCC KDB 662911 D01 Multiple Transmitter Output v02r01

The above equipment has been tested and found compliance with the requirement of the relative standards by BTL Inc.



Prepared by : Sheldon Ou



Approved by : Ethan Ma



Certificate #5123.02

Add: No.3, Jinshagang 1st Road, Shixia, Dalang Town, Dongguan, Guangdong, China.

Tel: +86-769-8318-3000

Web: www.newbtl.com

Declaration

BTL represents to the client that testing is done in accordance with standard procedures as applicable and that test instruments used has been calibrated with standards traceable to international standard(s) and/or national standard(s).

BTL's reports apply only to the specific samples tested under conditions. It is manufacture's responsibility to ensure that additional production units of this model are manufactured with the identical electrical and mechanical components. **BTL** shall have no liability for any declarations, inferences or generalizations drawn by the client or others from **BTL** issued reports.

The report must not be used by the client to claim product certification, approval, or endorsement by NVLAP, NIST, A2LA, or any agency of the U.S. Government.

This report is the confidential property of the client. As a mutual protection to the clients, the public and ourselves, the test report shall not be reproduced, except in full, without our written approval.

BTL's laboratory quality assurance procedures are in compliance with the **ISO/IEC 17025** requirements, and accredited by the conformity assessment authorities listed in this test report.

BTL is not responsible for the sampling stage, so the results only apply to the sample as received.

The information, data and test plan are provided by manufacturer which may affect the validity of results, so it is manufacturer's responsibility to ensure that the apparatus meets the essential requirements of applied standards and in all the possible configurations as representative of its intended use.

Limitation

For the use of the authority's logo is limited unless the Test Standard(s)/Scope(s)/Item(s) mentioned in this test report is (are) included in the conformity assessment authorities acceptance respective.

Please note that the measurement uncertainty is provided for informational purpose only and are not use in determining the Pass/Fail results.

Table of Contents	Page
REPORT ISSUED HISTORY	6
1 . SUMMARY OF TEST RESULTS	7
1.1 TEST FACILITY	8
1.2 MEASUREMENT UNCERTAINTY	8
1.3 TEST ENVIRONMENT CONDITIONS	9
2 . GENERAL INFORMATION	10
2.1 GENERAL DESCRIPTION OF EUT	10
2.2 TEST MODES	13
2.3 PARAMETERS OF TEST SOFTWARE	15
2.4 DUTY CYCLE	16
2.5 BLOCK DIAGRAM SHOWING THE CONFIGURATION OF SYSTEM TESTED	17
2.6 SUPPORT UNITS	17
3 . AC POWER LINE CONDUCTED EMISSIONS TEST	18
3.1 LIMIT	18
3.2 TEST PROCEDURE	18
3.3 DEVIATION FROM TEST STANDARD	18
3.4 TEST SETUP	19
3.5 EUT OPERATION CONDITIONS	19
3.6 TEST RESULTS	19
4 . RADIATED EMISSIONS TEST	20
4.1 LIMIT	20
4.2 TEST PROCEDURE	21
4.3 DEVIATION FROM TEST STANDARD	21
4.4 TEST SETUP	22
4.5 EUT OPERATION CONDITIONS	23
4.6 TEST RESULTS - 9 KHZ to 30 MHZ	23
4.7 TEST RESULTS - 30 MHz TO 1000 MHz	23
4.8 TEST RESULTS - ABOVE 1000 MHz	23
5 . BANDWIDTH TEST	24
5.1 LIMIT	24
5.2 TEST PROCEDURE	24
5.3 TEST PROCEDURE	24
5.4 TEST SETUP	24

Table of Contents	Page
5.5 EUT OPERATION CONDITIONS	25
5.6 TEST RESULTS	25
6 . MAXIMUM OUTPUT POWER TEST	26
6.1 LIMIT	26
6.2 TEST PROCEDURE	26
6.3 DEVIATION FROM STANDARD	26
6.4 TEST SETUP	26
6.5 EUT OPERATION CONDITIONS	26
6.6 TEST RESULTS	26
7 . POWER SPECTRAL DENSITY TEST	27
7.1 LIMIT	27
7.2 TEST PROCEDURE	27
7.3 DEVIATION FROM STANDARD	27
7.4 TEST SETUP	28
7.5 EUT OPERATION CONDITIONS	28
7.6 TEST RESULTS	28
8 . FREQUENCY STABILITY MEASUREMENT	29
8.1 LIMIT	29
8.2 TEST PROCEDURE	29
8.3 DEVIATION FROM STANDARD	29
8.4 TEST SETUP	29
8.5 EUT OPERATION CONDITIONS	29
8.6 TEST RESULTS	29
9 . MEASUREMENT INSTRUMENTS LIST	30
10 . EUT TEST PHOTOS	32
APPENDIX A - AC POWER LINE CONDUCTED EMISSIONS	37
APPENDIX B - RADIATED EMISSION - 9 KHZ TO 30 MHZ	40
APPENDIX C - RADIATED EMISSION - 30 MHZ TO 1 GHZ	45
APPENDIX D - RADIATED EMISSION - ABOVE 1000 MHZ	48
APPENDIX E - BANDWIDTH	201
APPENDIX F - MAXIMUM OUTPUT POWER	218
APPENDIX G - POWER SPECTRAL DENSITY	224

Table of Contents**Page****APPENDIX H - FREQUENCY STABILITY****233**

REPORT ISSUED HISTORY

Report Version	Description	Issued Date
R00	Original Issue.	Feb. 25, 2021
R01	Added EUT test photos of conducted emission.	Mar. 03, 2021

1. SUMMARY OF TEST RESULTS

Test procedures according to the technical standard(s):

FCC Part15, Subpart E(15.407)				
Standard(s) Section	Test Item	Test Result	Judgement	Remark
15.207 15.407(b)	AC Power Line Conducted Emissions	APPENDIX A	PASS	-----
15.407(b) 15.205(a) 15.209(a)	Radiated Emissions	APPENDIX B APPENDIX C APPENDIX D	PASS	-----
15.407(a) 15.407(e)	Spectrum Bandwidth	APPENDIX E	PASS	-----
15.407(a)	Maximum Output Power	APPENDIX F	PASS	-----
15.407(a)	Power Spectral Density	APPENDIX G	PASS	-----
15.407(g)	Frequency Stability	APPENDIX H	PASS	-----
15.203	Antenna Requirements	-----	PASS	NOTE (2)
15.407(c)	Automatically Discontinue Transmission	-----	PASS	NOTE (3)

Note:

- (1) "N/A" denotes test is not applicable in this test report.
- (2) The device what use a permanently attached antenna were considered sufficient to comply with the provisions of 15.203.
- (3) During no any information transmission, the EUT can automatically discontinue transmission and become standby mode for power saving. the EUT can detect the controlling signal of ACK message transmitting from remote device and verify whether it shall resend or discontinue transmission.
- (4) For UNII-1 this device was functioned as a
 Access point device Client device

1.1 TEST FACILITY

The test facilities used to collect the test data in this report is at the location of No.3,Jinshagang 1st Road, Shixia, Dalang Town, Dongguan, Guangdong, China.

BTL's Test Firm Registration Number for FCC: 357015

BTL's Designation Number for FCC: CN1240

1.2 MEASUREMENT UNCERTAINTY

ISO/IEC 17025 requires that an estimate of the measurement uncertainties associated with the emissions test results be included in the report. The measurement uncertainties given below are based on a 95% confidence level (based on a coverage factor (k=2))

The BTL measurement uncertainty as below table:

A. AC power line conducted emissions test:

Test Site	Method	Measurement Frequency Range	U, (dB)
DG-C02	CISPR	150kHz ~ 30MHz	2.68

B. Radiated emissions test:

Test Site	Method	Measurement Frequency Range	Ant. H / V	U, (dB)
DG-CB03	CISPR	9kHz ~ 30MHz	-	3.02
		30MHz ~ 200MHz	V	4.26
		30MHz ~ 200MHz	H	3.38
		200MHz ~ 1,000MHz	V	3.98
		200MHz ~ 1,000MHz	H	3.94
		1GHz ~ 6GHz	-	3.96
		6GHz ~ 18GHz	-	5.24
		18GHz ~ 26.5GHz	-	3.62
		26.5GHz ~ 40GHz	-	4.00

C. Other Measurement test:

Test Item	Uncertainty
Bandwidth	±3.8 %
Maximum Output Power	±0.95 dB
Power Spectral Density	±0.86 dB
Frequency Stability	±0.16 dB
Temperature	±0.08 °C
Humidity	±1.5%

Note: Unless specifically mentioned, the uncertainty of measurement has not been taken into account to declare the compliance or non-compliance to the specification.

1.3 TEST ENVIRONMENT CONDITIONS

Test Item	Temperature	Humidity	Test Voltage	Tested By
AC Power Line Conducted Emissions	25°C	53%	DC 3.3V	Gerry Zhao
Radiated Emissions-9K-30MHz	25°C	60%	DC 3.3V	Kwok Guo
Radiated Emissions-30 MHz to 1GHz	26°C	52%	DC 3.3V	Kwok Guo
Radiated Emissions-Above 1000 MHz	26°C	52%	DC 3.3V	Kwok Guo
Spectrum Bandwidth	24°C	49%	DC 3.3V	Kwok Guo
Maximum Output Power	24°C	49%	DC 3.3V	Hand Huang
Power Spectral Density	24°C	49%	DC 3.3V	Kwok Guo
Frequency Stability	Normal & Extreme	49%	Normal & Extreme	Kwok Guo

2. GENERAL INFORMATION

2.1 GENERAL DESCRIPTION OF EUT

Equipment	AC600 Wireless Dual Band PCI Express Adapter
Brand Name	tp-link
Test Model	Archer T2E
Series Model	N/A
Model Difference(s)	N/A
Software Version	2020,2024.0.10.127
Hardware Version	1.0
Power Source	DC voltage supplied from external power supply
Power Rating	DC 3.3V
Operation Frequency Bands	UNII-1: 5150 MHz ~ 5250 MHz UNII-2A: 5250 MHz ~ 5350 MHz UNII-2C: 5470 MHz ~ 5725 MHz UNII-3: 5725 MHz ~ 5850 MHz
Modulation Type	IEEE 802.11a/n/ac: OFDM
Bit Rate of Transmitter	IEEE 802.11a: 54/48/36/24/18/12/9/6 Mbps IEEE 802.11n: up to 150 Mbps IEEE 802.11ac: up to 433.3 Mbps
Maximum Conducted Output Power for UNII-1	IEEE 802.11a: 19.79 dBm (0.0953 W) IEEE 802.11ac (VHT20): 19.49 dBm (0.0889 W) IEEE 802.11ac (VHT40): 17.63 dBm (0.0579 W) IEEE 802.11ac (VHT80): 12.87 dBm (0.0194 W)
Maximum Conducted Output Power for UNII-2A	IEEE 802.11a: 18.73 dBm (0.0746 W) IEEE 802.11ac (VHT20): 18.82 dBm (0.0762 W) IEEE 802.11ac (VHT40): 17.94 dBm (0.0622 W) IEEE 802.11ac (VHT80): 12.36 dBm (0.0172 W)
Maximum Conducted Output Power for UNII-2C	IEEE 802.11a: 18.60 dBm (0.0724 W) IEEE 802.11ac (VHT20): 18.59 dBm (0.0723 W) IEEE 802.11ac (VHT40): 18.13 dBm (0.0650 W) IEEE 802.11ac (VHT80): 16.35 dBm (0.0432 W)
Maximum Conducted Output Power for UNII-3	IEEE 802.11a: 18.39 dBm (0.0690 W) IEEE 802.11ac (VHT20): 18.34 dBm (0.0682 W) IEEE 802.11ac (VHT40): 18.28 dBm (0.0673 W) IEEE 802.11ac (VHT80): 17.75 dBm (0.0596 W)

Note:

1. For a more detailed features description, please refer to the manufacturer's specifications or the user's manual.

2. Channel List:

IEEE 802.11a IEEE 802.11n(HT20) IEEE 802.11ac (VHT20)		IEEE 802.11n(HT40) IEEE 802.11ac (VHT40)		IEEE 802.11ac (VHT80)	
UNII-1		UNII-1		UNII-1	
Channel	Frequency (MHz)	Channel	Frequency (MHz)	Channel	Frequency (MHz)
36	5180	38	5190	42	5210
40	5200	46	5230		
44	5220				
48	5240				

IEEE 802.11a IEEE 802.11n(HT20) IEEE 802.11ac (VHT20)		IEEE 802.11n(HT40) IEEE 802.11ac (VHT40)		IEEE 802.11ac (VHT80)	
UNII-2A		UNII-2A		UNII-2A	
Channel	Frequency (MHz)	Channel	Frequency (MHz)	Channel	Frequency (MHz)
52	5260	54	5270	58	5290
56	5280	62	5310		
60	5300				
64	5320				

IEEE 802.11a IEEE 802.11n(HT20) IEEE 802.11ac (VHT20)		IEEE 802.11n(HT40) IEEE 802.11ac (VHT40)		IEEE 802.11ac (VHT80)	
UNII-2C		UNII-2C		UNII-2C	
Channel	Frequency (MHz)	Channel	Frequency (MHz)	Channel	Frequency (MHz)
100	5500	102	5510	106	5530
104	5520	110	5550	122	5610
108	5540	118	5590		
112	5560	126	5630		
116	5580	134	5670		
120	5600				
124	5620				
128	5640				
132	5660				
136	5680				
140	5700				

IEEE 802.11a IEEE 802.11n(HT20) IEEE 802.11ac (VHT20)		IEEE 802.11n(HT40) IEEE 802.11ac (VHT40)		IEEE 802.11ac (VHT80)	
UNII-3		UNII-3		UNII-3	
Channel	Frequency (MHz)	Channel	Frequency (MHz)	Channel	Frequency (MHz)
149	5745	151	5755	155	5775
153	5765	159	5795		
157	5785				
161	5805				
165	5825				

3. Antenna Specification:

Ant.	Brand	P/N	Antenna Type	Connector	Gain (dBi)	Note
1	tp-link	3101503058	Dipole	RP-SMA-F	4.52	Band 1
1	tp-link	3101503058	Dipole	RP-SMA-F	4.72	Band 2
1	tp-link	3101503058	Dipole	RP-SMA-F	4.83	Band 3
1	tp-link	3101503058	Dipole	RP-SMA-F	3.96	Band 4

Note:

The antenna gain is provided by the manufacturer.

2.2 TEST MODES

The test system was pre-tested based on the consideration of all possible combinations of EUT operation mode.

Pretest Mode	Description
Mode 1	TX A Mode / CH36, CH40, CH48 (UNII-1)
Mode 2	TX AC (VHT20) Mode / CH36, CH40, CH48 (UNII-1)
Mode 3	TX AC (VHT40) Mode / CH38, CH46 (UNII-1)
Mode 4	TX AC (VHT80) Mode / CH42 (UNII-1)
Mode 5	TX A Mode / CH52, CH60, CH64 (UNII-2A)
Mode 6	TX AC (VHT20) Mode / CH52, CH60, CH64 (UNII-2A)
Mode 7	TX AC (VHT40) Mode / CH54, CH62 (UNII-2A)
Mode 8	TX AC (VHT80) Mode / CH58 (UNII-2A)
Mode 9	TX A Mode / CH100, CH116, CH140 (UNII-2C)
Mode 10	TX AC (VHT20) Mode / CH100, CH116, CH140 (UNII-2C)
Mode 11	TX AC (VHT40) Mode / CH102, CH110, CH134 (UNII-2C)
Mode 12	TX AC (VHT80) Mode / CH106, CH122 (UNII-2C)
Mode 13	TX A Mode / CH149,CH157,CH165 (UNII-3)
Mode 14	TX AC (VHT20) Mode / CH149,CH157,CH165 (UNII-3)
Mode 15	TX AC (VHT40) Mode / CH151,CH159 (UNII-3)
Mode 16	TX AC (VHT80) Mode / CH155 (UNII-3)
Mode 17	TX A Mode / CH40 (UNII-1)

Following mode(s) was (were) found to be the worst case(s) and selected for the final test.

AC power line conducted emissions test	
Final Test Mode	Description
Mode 17	TX A Mode / CH40 (UNII-1)

Radiated Emissions Test - Below 1GHz	
Final Test Mode	Description
Mode 17	TX A Mode / CH40 (UNII-1)

Radiated emissions test - Above 1GHz	
Final Test Mode	Description
Mode 1	TX A Mode / CH36, CH40, CH48 (UNII-1)
Mode 2	TX AC (VHT20) Mode / CH36, CH40, CH48 (UNII-1)
Mode 3	TX AC (VHT40) Mode / CH38, CH46 (UNII-1)
Mode 4	TX AC (VHT80) Mode / CH42 (UNII-1)
Mode 5	TX A Mode / CH52, CH60, CH64 (UNII-2A)
Mode 6	TX AC (VHT20) Mode / CH52, CH60, CH64 (UNII-2A)
Mode 7	TX AC (VHT40) Mode / CH54, CH62 (UNII-2A)
Mode 8	TX AC (VHT80) Mode / CH58 (UNII-2A)
Mode 9	TX A Mode / CH100, CH116, CH140 (UNII-2C)
Mode 10	TX AC (VHT20) Mode / CH100, CH116, CH140 (UNII-2C)
Mode 11	TX AC (VHT40) Mode / CH102, CH110, CH134 (UNII-2C)
Mode 12	TX AC (VHT80) Mode / CH106, CH122 (UNII-2C)
Mode 13	TX A Mode / CH149,CH157,CH165 (UNII-3)
Mode 14	TX AC (VHT20) Mode / CH149,CH157,CH165 (UNII-3)
Mode 15	TX AC (VHT40) Mode / CH151,CH159 (UNII-3)
Mode 16	TX AC (VHT80) Mode / CH155 (UNII-3)

Conducted test	
Test Mode	Description
Mode 1	TX A Mode / CH36, CH40, CH48 (UNII-1)
Mode 2	TX AC (VHT20) Mode / CH36, CH40, CH48 (UNII-1)
Mode 3	TX AC (VHT40) Mode / CH38, CH46 (UNII-1)
Mode 4	TX AC (VHT80) Mode / CH42 (UNII-1)
Mode 5	TX A Mode / CH52, CH60, CH64 (UNII-2A)
Mode 6	TX AC (VHT20) Mode / CH52, CH60, CH64 (UNII-2A)
Mode 7	TX AC (VHT40) Mode / CH54, CH62 (UNII-2A)
Mode 8	TX AC (VHT80) Mode / CH58 (UNII-2A)
Mode 9	TX A Mode / CH100, CH116, CH140 (UNII-2C)
Mode 10	TX AC (VHT20) Mode / CH100, CH116, CH140 (UNII-2C)
Mode 11	TX AC (VHT40) Mode / CH102, CH110, CH134 (UNII-2C)
Mode 12	TX AC (VHT80) Mode / CH106, CH122 (UNII-2C)
Mode 13	TX A Mode / CH149,CH157,CH165 (UNII-3)
Mode 14	TX AC (VHT20) Mode / CH149,CH157,CH165 (UNII-3)
Mode 15	TX AC (VHT40) Mode / CH151,CH159 (UNII-3)
Mode 16	TX AC (VHT80) Mode / CH155 (UNII-3)

Note:

- (1) For radiated emission below 1 GHz test, the IEEE 802.11a channel 40 is found to be the worst case and recorded.
- (2) For radiated emission above 1 GHz test, 1GHz~26.5GHz and 26.5GHz~40GHz have been pre-tested and in this report only recorded the worst case. The remaining spurious points are all below the limit value of 20dB.
- (3) VHT20/VHT40 covers HT20/HT40, due to same modulation. The power setting for 802.11n HT20 and HT40 are the same or lower than 802.11ac VHT20 and VHT40.

2.3 PARAMETERS OF TEST SOFTWARE

Test Software	MP_Kit_RTL11ac_8821CE_PCIE V8.00
---------------	----------------------------------

2.4 DUTY CYCLE

If duty cycle is $\geq 98\%$, duty factor is not required.

If duty cycle is $< 98\%$, duty factor shall be considered.

The output power = measured power + duty factor.

The power spectral density = measured power spectral density + duty factor.

IEEE 802.11a

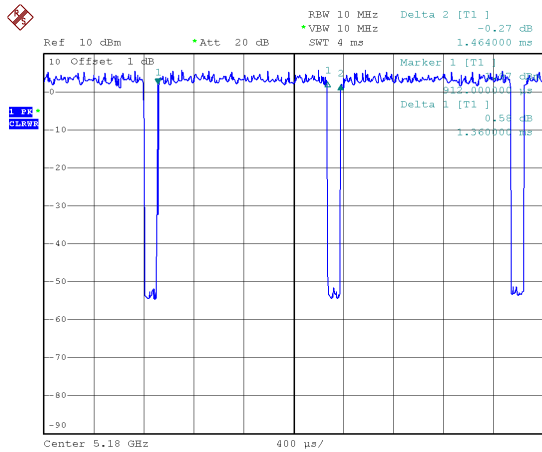

IEEE 802.11ac (VHT20)

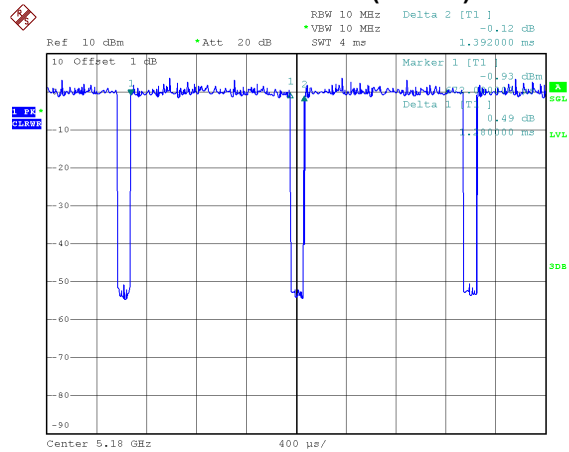

Date: 21.DEC.2020 14:10:32

Duty cycle = 1.360 ms / 1.464 ms = 92.90%
Duty Factor = $10 * \log(1 / \text{Duty cycle}) = 0.32$

Date: 21.DEC.2020 14:11:36

Duty cycle = 1.280 ms / 1.392 ms = 91.95%
Duty Factor = $10 * \log(1 / \text{Duty cycle}) = 0.36$

IEEE 802.11ac (VHT40)

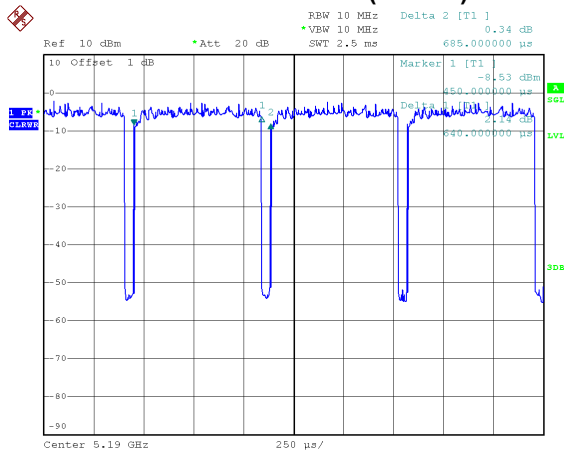

IEEE 802.11ac (VHT80)

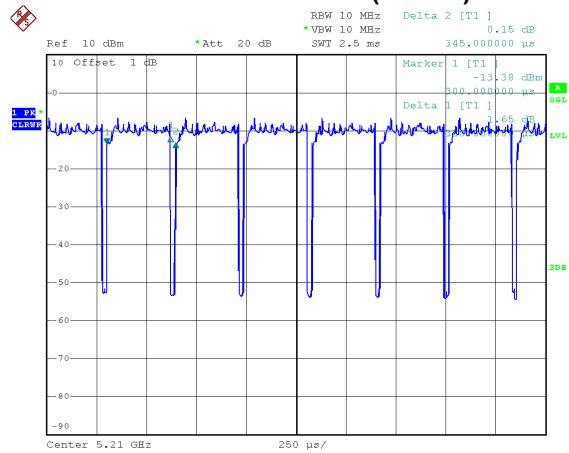

Date: 21.DEC.2020 14:12:25

Duty cycle = 0.640 ms / 0.685 ms = 93.43%
Duty Factor = $10 * \log(1 / \text{Duty cycle}) = 0.30$

Date: 21.DEC.2020 14:12:48

Duty cycle = 0.320 ms / 0.345 ms = 92.75%
Duty Factor = $10 * \log(1 / \text{Duty cycle}) = 0.33$

NOTE:

For IEEE 802.11a and IEEE 802.11ac (VHT20):

For radiated emissions frequency above 1 GHz, the resolution bandwidth of test receiver/spectrum analyzer is 1 MHz and the video bandwidth is 1 kHz (Duty cycle $< 98\%$).

For IEEE 802.11ac (VHT40):

For radiated emissions frequency above 1 GHz, the resolution bandwidth of test receiver/spectrum analyzer is 1 MHz and the video bandwidth is 2 kHz (Duty cycle $< 98\%$).

For IEEE 802.11ac (VHT80):

For radiated emissions frequency above 1 GHz, the resolution bandwidth of test receiver/spectrum analyzer is 1 MHz and the video bandwidth is 3 kHz (Duty cycle $< 98\%$).

2.5 BLOCK DIAGRAM SHOWING THE CONFIGURATION OF SYSTEM TESTED

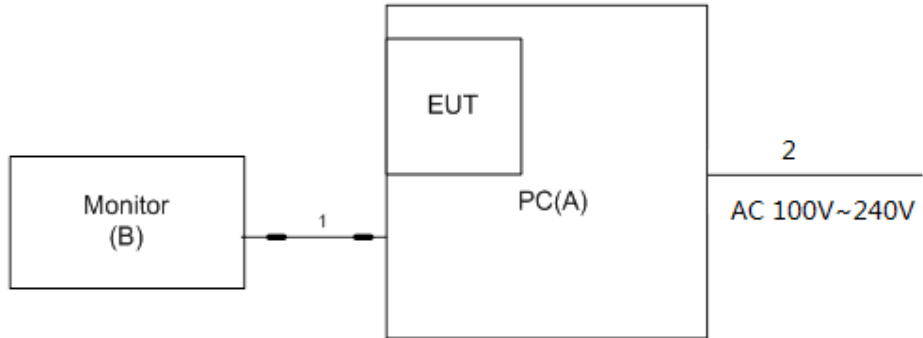

2.6 SUPPORT UNITS

Item	Equipment	Brand	Model/Type No.	Series No.
A	PC	DELL	DELL XPS	8920-D15N8
B	Monitor	DELL	IPS234TA	202NDPHD6032

Item	Cable Type	Shielded Type	Ferrite Core	Length
1	AC Cable	NO	NO	1.5m
2	D-SUB Cable	NO	NO	1.5m

3. AC POWER LINE CONDUCTED EMISSIONS TEST

3.1 LIMIT

Frequency (MHz)	Limit (dB μ V)	
	Quasi-peak	Average
0.15 - 0.5	66 to 56*	56 to 46*
0.5 - 5.0	56	46
5.0 - 30.0	60	50

NOTE:

- (1) The tighter limit applies at the band edges.
- (2) The limit of " * " marked band means the limitation decreases linearly with the logarithm of the frequency in the range.

The following table is the setting of the receiver

Receiver Parameter	Setting
Attenuation	10 dB
Start Frequency	0.15 MHz
Stop Frequency	30 MHz
IF Bandwidth	9 KHz

3.2 TEST PROCEDURE

- a. The EUT was placed 0.8 meters from the horizontal ground plane with EUT being connected to the power mains through a line impedance stabilization network (LISN). All other support equipment powered from additional LISN(s). The LISN provide 50 Ohm/ 50uH of coupling impedance for the measuring instrument.
- b. Interconnecting cables that hang closer than 40 cm to the ground plane shall be folded back and forth in the center forming a bundle 30 to 40 cm long.
- c. I/O cables that are not connected to a peripheral shall be bundled in the center. The end of the cable may be terminated, if required, using the correct terminating impedance. The overall length shall not exceed 1 m.
- d. LISN at least 80 cm from nearest part of EUT chassis.
- e. For the actual test configuration, please refer to the related Item -EUT Test Photos.

3.3 DEVIATION FROM TEST STANDARD

No deviation

3.4 TEST SETUP

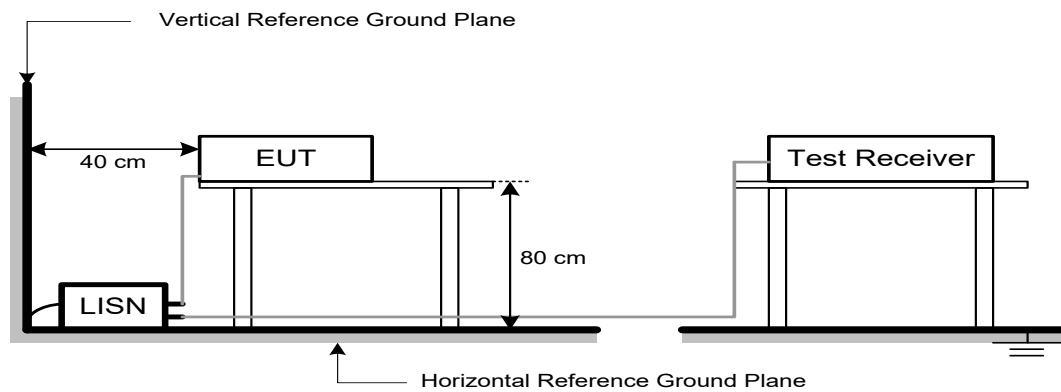

3.5 EUT OPERATION CONDITIONS

The EUT was configured for testing in a typical fashion (as a customer would normally use it). The EUT has been programmed to continuously transmit during test. This operating condition was tested and used to collect the included data.

The EUT was programmed to be in continuously transmitting/TX mode.

3.6 TEST RESULTS

Please refer to the APPENDIX A.

4. RADIATED EMISSIONS TEST

4.1 LIMIT

In case the emission fall within the restricted band specified on 15.205(a), then the 15.209(a) limit in the table below has to be followed.

LIMITS OF RADIATED EMISSION MEASUREMENT (9 kHz-1000 MHz)

Frequency (MHz)	Field Strength (microvolts/meter)	Measurement Distance (meters)
0.009-0.490	2400/F(kHz)	300
0.490-1.705	24000/F(kHz)	30
1.705-30.0	30	30
30-88	100	3
88-216	150	3
216-960	200	3
Above 960	500	3

LIMITS OF RADIATED EMISSION MEASUREMENT (Above 1000 MHz)

Frequency (MHz)	EIRP Limit (dBm/MHz)	Equivalent Field Strength at 3m (dBμV/m)
5150-5250	-27	68.2
5250-5350	-27	68.2
5470-5725	-27	68.2
5725-5850 NOTE (2)	-27	68.2
	10	105.2
	15.6	110.8
	27	122.2

NOTE:

- (1) The following formula is used to convert the equipment isotropic radiated power (eirp) to field strength:

$$E = \frac{1000000\sqrt{30P}}{3} \mu\text{V/m, where P is the eirp (Watts)}$$

- (2) According to 15.407(b)(4)(i), all emissions shall be limited to a level of -27 dBm/MHz at 75 MHz or more above or below the band edge increasing linearly to 10 dBm/MHz at 25 MHz above or below the band edge, and from 25 MHz above or below the band edge increasing linearly to a level of 15.6 dBm/MHz at 5 MHz above or below the band edge, and from 5 MHz above or below the band edge increasing linearly to a level of 27 dBm/MHz at the band edge.

4.2 TEST PROCEDURE

- a. The measuring distance of 3 m shall be used for measurements. The EUT was placed on the top of a rotating table 0.8 meter above the ground at a 3 meter semi-anechoic chamber. The table was rotated 360 degrees to determine the position of the highest radiation.(below 1GHz)
- b. The measuring distance of 3 m shall be used for measurements. The EUT was placed on the top of a rotating table 1.5 meter above the ground at a 3 meter semi-anechoic chamber. The table was rotated 360 degrees to determine the position of the highest radiation.(above 1GHz)
- c. The height of the equipment or of the substitution antenna shall be 0.8m or 1.5m; the height of the test antenna shall vary between 1 m to 4 m. Both horizontal and vertical polarizations of the antenna are set to make the measurement.
- d. For each suspected emission, the EUT was arranged to its worst case and then the antenna was tuned to heights find the maximum reading (used Bore sight function).
- e. The receiver system was set to peak and average detect function and specified bandwidth with maximum hold mode when the test frequency is above 1 GHz.
- f. The initial step in collecting radiated emission data is a receiver peak detector mode pre-scanning the measurement frequency range. Significant peaks are then marked and then Quasi Peak detector mode re-measured.
- g. All readings are Peak unless otherwise stated QP in column of Note. Peak denotes that the Peak reading compliance with the QP Limits and then QP Mode measurement didn't perform. (below 1 GHz)
- h. All readings are Peak Mode value unless otherwise stated AVG in column of Note. If the Peak Mode Measured value compliance with the Peak Limits and lower than AVG Limits, the EUT shall be deemed to meet both Peak & AVG Limits and then only Peak Mode was measured, but AVG Mode didn't perform. (above 1 GHz)
- i. For the actual test configuration, please refer to the related Item –EUT Test Photos.

The following table is the setting of the receiver:

Spectrum Parameters	Setting
Start ~ Stop Frequency	9 kHz~150 kHz for RBW 200 Hz
Start ~ Stop Frequency	0.15 MHz~30 MHz for RBW 9 kHz
Start ~ Stop Frequency	30 MHz~1000 MHz for RBW 100 kHz

Spectrum Parameters	Setting
Start Frequency	1000 MHz
Stop Frequency	10th carrier harmonic or 40 GHz, whichever is lower
RBW / VBW (Emission in restricted band)	1 MHz / 3 MHz for PK value 1 MHz / 1/T Hz for AVG value

Receiver Parameters	Setting
Start ~ Stop Frequency	9 kHz~90 kHz for PK/AVG detector
Start ~ Stop Frequency	90 kHz~110 kHz for QP detector
Start ~ Stop Frequency	110 kHz~490 kHz for PK/AVG detector
Start ~ Stop Frequency	490 kHz~30 MHz for QP detector
Start ~ Stop Frequency	30 MHz~1000 MHz for QP detector
Start ~ Stop Frequency	1 GHz~40 GHz for PK/AVG detector

4.3 DEVIATION FROM TEST STANDARD

No deviation

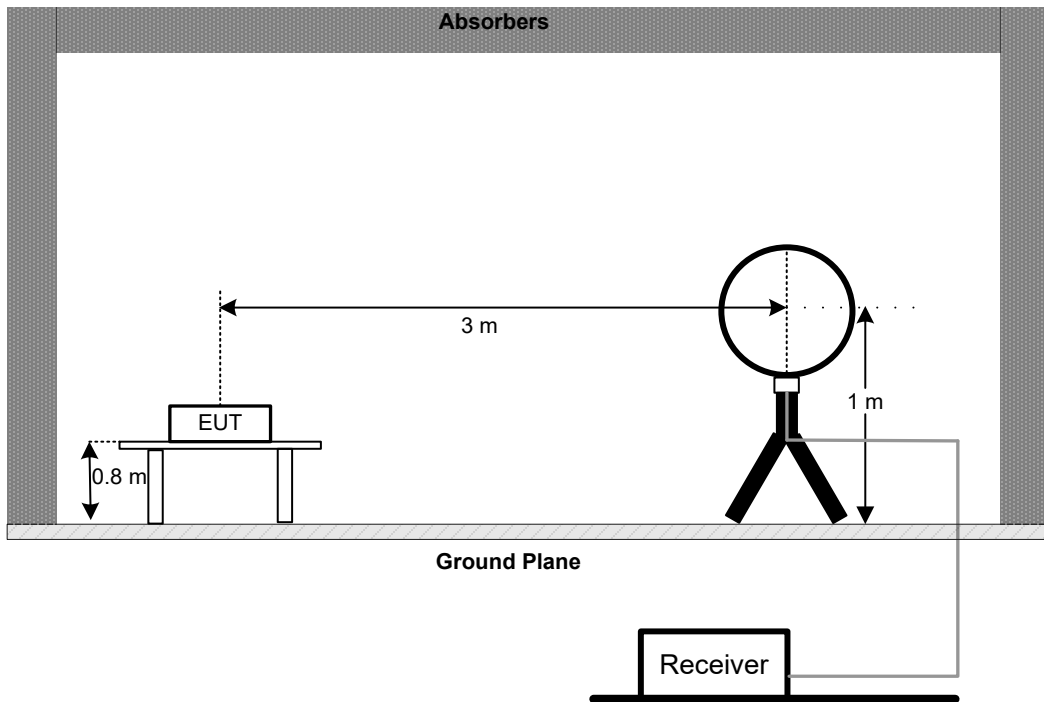
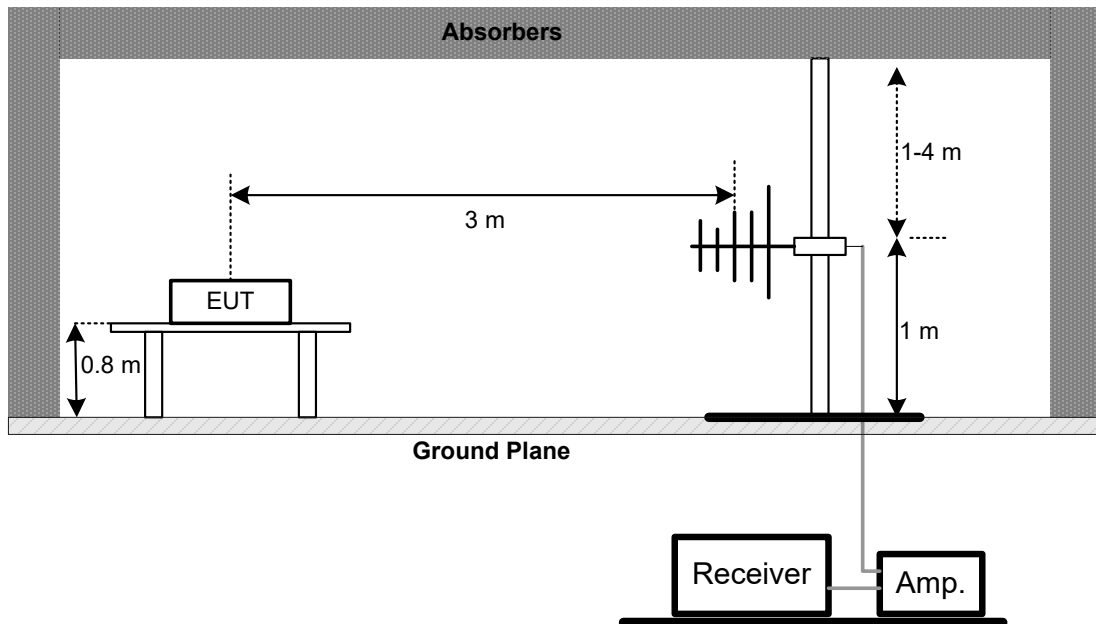
4.4 TEST SETUP**9 kHz to 30 MHz****30 MHz to 1 GHz**

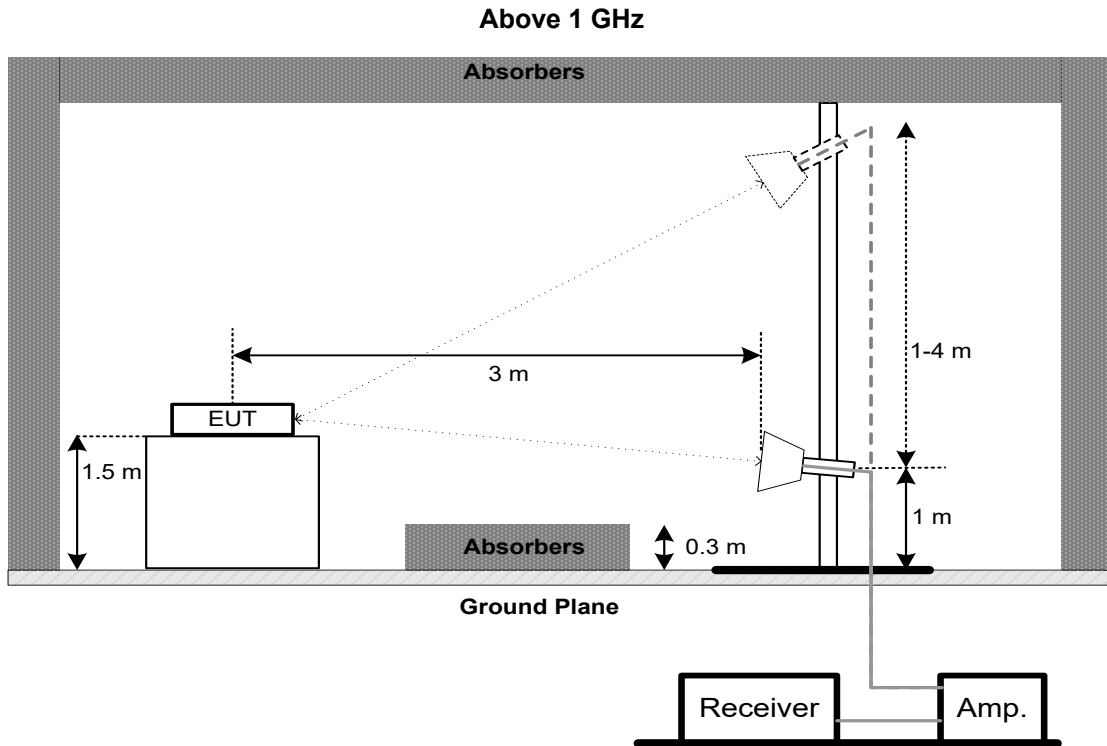

4.5 EUT OPERATION CONDITIONS

The EUT tested system was configured as the statements of 3.5 unless otherwise a special operating condition is specified in the follows during the testing.

4.6 TEST RESULTS - 9 KHZ to 30 MHZ

Please refer to the APPENDIX B

Remark:

- (1) The amplitude of spurious emissions which are attenuated by more than 20 dB below the permissible value has no need to be reported.
- (2) Distance extrapolation factor = $40 \log (\text{specific distance} / \text{test distance})$ (dB).
- (3) Limit line = specific limits (dBuV) + distance extrapolation factor.

4.7 TEST RESULTS - 30 MHZ TO 1000 MHZ

Please refer to the APPENDIX C.

4.8 TEST RESULTS - ABOVE 1000 MHZ

Please refer to the APPENDIX D.

Remark:

- (1) No limit: This is fundamental signal, the judgment is not applicable.
For fundamental signal judgment was referred to Peak output test.

5. BANDWIDTH TEST

5.1 LIMIT

Section	Test Item	Limit	Frequency Range (MHz)
FCC 15.407(a) FCC 15.407(e)	26 dB Bandwidth	-	5150-5250
	26 dB Bandwidth	-	5250-5350
	26 dB Bandwidth	-	5470-5725
	6 dB Bandwidth	Minimum 500 kHz	5725-5850

5.2 TEST PROCEDURE

- a. The EUT was directly connected to the spectrum analyzer and antenna output port as show in the block diagram below
- b. Spectrum Setting:
For UNII-1, UNII-2A, UNII-2C:

Spectrum Parameter	Setting
Attenuation	Auto
Span Frequency	> 26 dB Bandwidth
RBW	300 kHz (Bandwidth 20 MHz) 1 MHz (Bandwidth 40 MHz and 80 MHz)
VBW	1 MHz (Bandwidth 20 MHz) 3 MHz (Bandwidth 40 MHz and 80 MHz)
Detector	Peak
Trace	Max Hold
Sweep Time	Auto

For UNII-3:

Spectrum Parameter	Setting
Attenuation	Auto
Span Frequency	6 dB Bandwidth
RBW	100 kHz
VBW	300 kHz
Detector	Peak
Trace	Max Hold
Sweep Time	Auto

- c. Measured the spectrum width with power higher than 26 dB / 6 dB below carrier.

5.3 TEST PROCEDURE

No deviation.

5.4 TEST SETUP

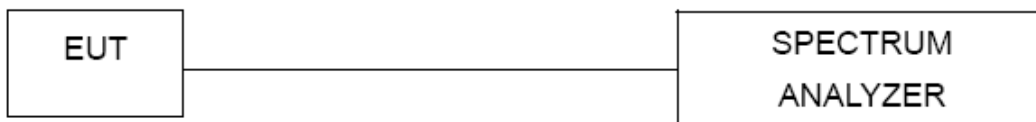

5.5 EUT OPERATION CONDITIONS

The EUT was programmed to be in continuously transmitting mode.

5.6 TEST RESULTS

Please refer to the APPENDIX E.

6. MAXIMUM OUTPUT POWER TEST

6.1 LIMIT

FCC Part15, Subpart E (15.407)			
Section	Test Item	Limit	Frequency Range (MHz)
15.407(a)	Conducted Output Power	AP device: 1 Watt (30 dBm) Client device: 250 mW (24 dBm)	5150-5250
		250 mW (24 dBm)	5250-5350
		250 mW (24 dBm)	5470-5725
		1 Watt (30dBm)	5725-5850

Note:

- a. For client devices in the 5.15-5.25 GHz band, the maximum conducted output power over the frequency band of operation shall not exceed 250 mW provided the maximum antenna gain does not exceed 6 dBi. In addition, the maximum power spectral density shall not exceed 11 dBm in any 1 megahertz band. If transmitting antennas of directional gain greater than 6 dBi are used, both the maximum conducted output power and the maximum power spectral density shall be reduced by the amount in dB that the directional gain of the antenna exceeds 6 dBi.
- b. For the 5.25-5.35 GHz and 5.47-5.725 GHz bands, the maximum conducted output power over the frequency bands of operation shall not exceed the lesser of 250 mW or 11 dBm + 10log B, where B is the 26dB Bandwidth in megahertz.

6.2 TEST PROCEDURE

- a. The EUT was directly connected to the power meter and antenna output port as show in the block diagram below.
- b. Test test was performed in accordance with method of FCC KDB 789033 D02 General UNII Test Procedures New Rules v02r01.

6.3 DEVIATION FROM STANDARD

No deviation.

6.4 TEST SETUP



6.5 EUT OPERATION CONDITIONS

The EUT was programmed to be in continuously transmitting mode.

6.6 TEST RESULTS

Please refer to the APPENDIX F.

7. POWER SPECTRAL DENSITY TEST

7.1 LIMIT

FCC Part15, Subpart E (15.407)			
Section	Test Item	Limit	Frequency Range (MHz)
15.407(a)	Power Spectral Density	AP device: 17 dBm/MHz Client device: 11 dBm/MHz	5150-5250
		11 dBm/MHz	5250-5350
		11 dBm/MHz	5470-5725
		30 dBm/500 kHz	5725-5850

7.2 TEST PROCEDURE

- a. The EUT was directly connected to the spectrum analyzer and antenna output port as show in the block diagram below.
- b. Spectrum Setting

Spectrum Parameter	Setting
Attenuation	Auto
Span Frequency	Encompass the entire emissions bandwidth (EBW) of the signal
RBW	= 1 MHz.
VBW	≥ 3 MHz.
Detector	RMS
Trace average	100 trace
Sweep Time	Auto

Note:

1. For UNII-3, according to KDB publication 789033 D02 General UNII Test Procedures New Rules v02r01, section II.F.5., it is acceptable to set RBW at 1 MHz and VBW at 3 MHz if the spectrum analyzer does not have 500 kHz RBW.
2. The value measured with RBW=1 MHz is to be added with $10\log(500 \text{ kHz}/1 \text{ MHz})$ which is -3 dB. For example, if the measured value is +10dBm using RBW=1 MHz (that is +10 dBm/MHz), then the converted value will be +7dBm/500kHz.

7.3 DEVIATION FROM STANDARD

No deviation.

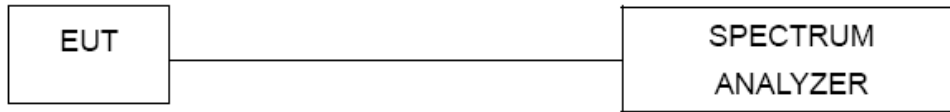
7.4 TEST SETUP**7.5 EUT OPERATION CONDITIONS**

The EUT was programmed to be in continuously transmitting mode.

7.6 TEST RESULTS

Please refer to the APPENDIX G.

8. FREQUENCY STABILITY MEASUREMENT

8.1 LIMIT

FCC Part15, Subpart E (15.407)			
Section	Test Item	Limit	Frequency Range (MHz)
15.407(g)	Frequency Stability	An emission is maintained within the band of operation under all conditions of normal operation as specified in the users manual.	5150-5250
			5250-5350
			5470-5725
			5725-5850

8.2 TEST PROCEDURE

- a. The EUT was directly connected to the spectrum analyzer and antenna output port as show in the block diagram below.
- b. Spectrum Setting:

Spectrum Parameter	Setting
Attenuation	Auto
Span Frequency	Entire absence of modulation emissions bandwidth
RBW	10 kHz
VBW	10 kHz
Sweep Time	Auto

- c. The test extreme voltage is to change the primary supply voltage from 85 to 115 percent of the nominal value.
- d. User manual temperature is 0°C~40°C.

8.3 DEVIATION FROM STANDARD

No deviation.

8.4 TEST SETUP

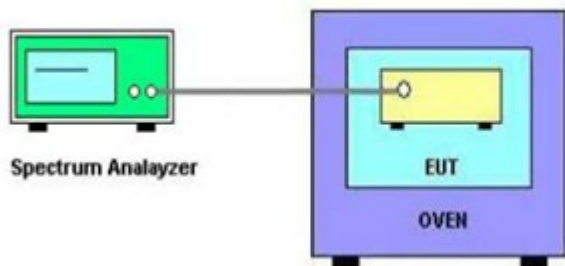

8.5 EUT OPERATION CONDITIONS

The EUT was programmed to be in continuously transmitting mode.

8.6 TEST RESULTS

Please refer to the APPENDIX H.

9. MEASUREMENT INSTRUMENTS LIST

AC Power Line Conducted Emissions					
Item	Kind of Equipment	Manufacturer	Type No.	Serial No.	Calibrated until
1	EMI Test Receiver	R&S	ESCI	100382	Feb. 28, 2021
2	LISN	EMCO	3816/2	52765	Mar. 01, 2021
3	TWO-LINE V-NETWORK	R&S	ENV216	101447	Feb. 28, 2021
4	50Ω Terminator	SHX	TF5-3	15041305	Mar. 01, 2021
5	Measurement Software	Farad	EZ-EMC Ver.NB-03A1-01	N/A	N/A
6	Cable	N/A	RG223	12m	Mar. 10, 2021
7	643 Shield Room	ETS	6*4*3m	N/A	N/A

Radiated Emissions - 9 kHz to 30 MHz					
Item	Kind of Equipment	Manufacturer	Type No.	Serial No.	Calibrated until
1	Antenna	EM	EM-6876-1	230	Apr. 16, 2021
2	Cable	N/A	RG 213/U	N/A	May 29, 2021
3	EMI Test Receiver	R&S	ESCI	100895	Feb. 28, 2021
4	Measurement Software	Farad	EZ-EMC Ver.NB-03A1-01	N/A	N/A
5	966 Chambe Room	RM	9*6*6m	N/A	Jul. 25, 2021

Radiated Emissions - 30 MHz to 1 GHz					
Item	Kind of Equipment	Manufacturer	Type No.	Serial No.	Calibrated until
1	Antenna	Schwarzbeck	VULB9160	9160-3232	Mar. 09, 2021
2*	Amplifier	HP	8447D	2944A09673	Aug. 11, 2021
3	Receiver	Agilent	N9038A	MY52130039	Jul. 25, 2021
4	Cable	emci	LMR-400(30MHz-1 GHz)(8m+5m)	N/A	May 22, 2021
5	Controller	CT	SC100	N/A	N/A
6	Controller	MF	MF-7802	MF780208416	N/A
7	Measurement Software	Farad	EZ-EMC Ver.NB-03A1-01	N/A	N/A
8	966 Chambe Room	RM	9*6*6m	N/A	Jul. 25, 2021

Radiated Emissions - Above 1 GHz					
Item	Kind of Equipment	Manufacturer	Type No.	Serial No.	Calibrated until
1	Double Ridged Guide Antenna	ETS	3115	75789	May 12, 2021
2	Broad-Band Horn Antenna	Schwarzbeck	BBHA 9170	9170319	Jul. 07, 2021
3	Amplifier	Agilent	8449B	3008A02333	Mar. 01, 2021
4	Microwave Preamplifier With Adaptor	EMC INSTRUMENT	EMC2654045	980039 & HA01	Mar. 07, 2021
5	Receiver	Agilent	N9038A	MY52130039	Jul. 25, 2021
6	Controller	CT	SC100	N/A	N/A
7	Controller	MF	MF-7802	MF780208416	N/A
8	Cable	N/A	EMC104-SM-SM-6000	N/A	May 09, 2021
9	Measurement Software	Farad	EZ-EMC Ver.NB-03A1-01	N/A	N/A
10	Band Reject Filter	Micro-Tronics	BRC50705-01	10	Feb. 28, 2021
11	Band Reject Filter	Micro-Tronics	BRC50704-01	8	Feb. 28, 2021
12	Band Reject Filter	Micro-Tronics	BRC50703-01	7	Feb. 28, 2021
13	966 Chambe Room	RM	9*6*6m	N/A	Jul. 25, 2021

Bandwidth					
Item	Kind of Equipment	Manufacturer	Type No.	Serial No.	Calibrated until
1	Spectrum Analyzer	R&S	FSP40	100185	Jul. 25, 2021
2	RF Cable	Tongkaichuan	N/A	N/A	N/A
3	DC Block	Mini	N/A	N/A	N/A
4	Attenuator	WOKEN	6SM3502	VAS1214NL	Feb. 07, 2022

Power Spectral Density					
Item	Kind of Equipment	Manufacturer	Type No.	Serial No.	Calibrated until
1	RF Cable	Tongkaichuan	N/A	N/A	N/A
2	DC Block	Mini	N/A	N/A	N/A
3	Attenuator	WOKEN	6SM3502	VAS1214NL	Feb. 07, 2022
4	EXA Spectrum Analyzer	Agilent	N9010A	MY50520044	Mar. 01, 2021

Maximum Output Power					
Item	Kind of Equipment	Manufacturer	Type No.	Serial No.	Calibrated until
1	Peak Power Analyzer	Keysight	8990B	MY51000506	Aug. 07, 2021
2	Wideband power sensor	Keysight	N1923A	MY58310004	Jul. 25, 2021
3	Attenuator	WOKEN	6SM3502	VAS1214NL	Feb. 11, 2021
4	RF Cable	Tongkaichuan	N/A	N/A	N/A

Frequency Stability					
Item	Kind of Equipment	Manufacturer	Type No.	Serial No.	Calibrated until
1	Spectrum Analyzer	R&S	FSP40	100185	Jul. 25, 2021
2	Precision Oven Tester	CEPREI	CEEC-M64T-40	15-008	Feb. 28, 2021
3	RF Cable	Tongkaichuan	N/A	N/A	N/A
4	DC Block	Mini	N/A	N/A	N/A
5	Attenuator	WOKEN	6SM3502	VAS1214NL	Feb. 07, 2022

Remark: "N/A" denotes no model name, serial no. or calibration specified.

"**" calibration period of equipment list is three year.

Except * item, all calibration period of equipment list is one year.

10. EUT TEST PHOTOS**AC Power Line Conducted Emissions Test Photos**

Radiated Emissions Test Photos**9 kHz to 30 MHz**

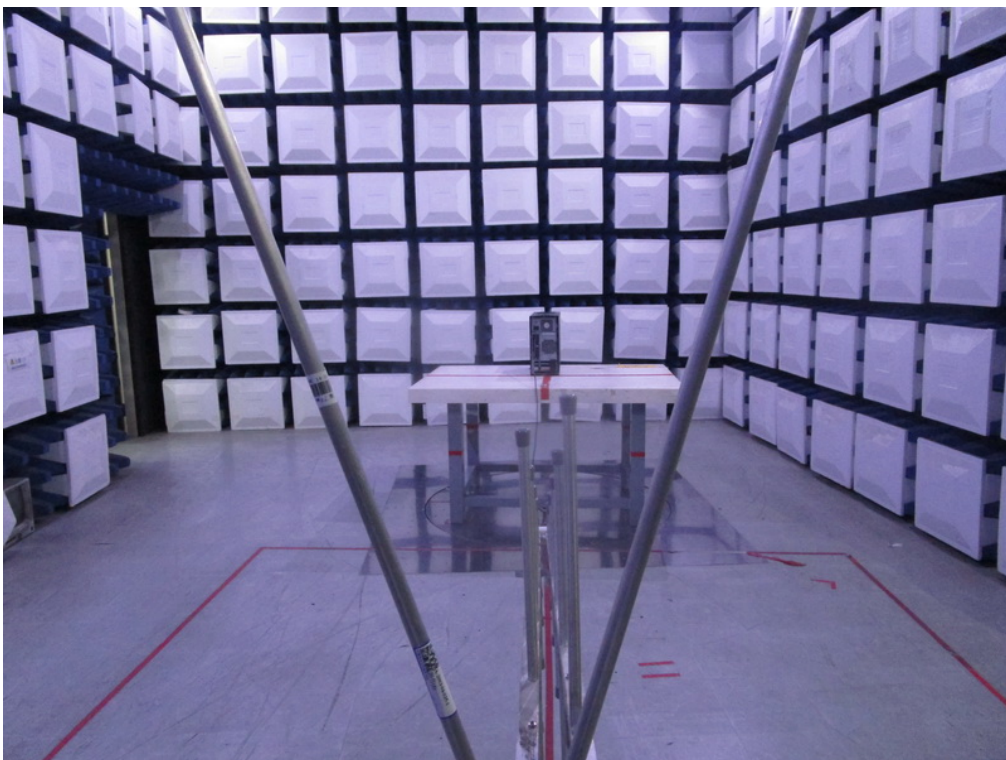
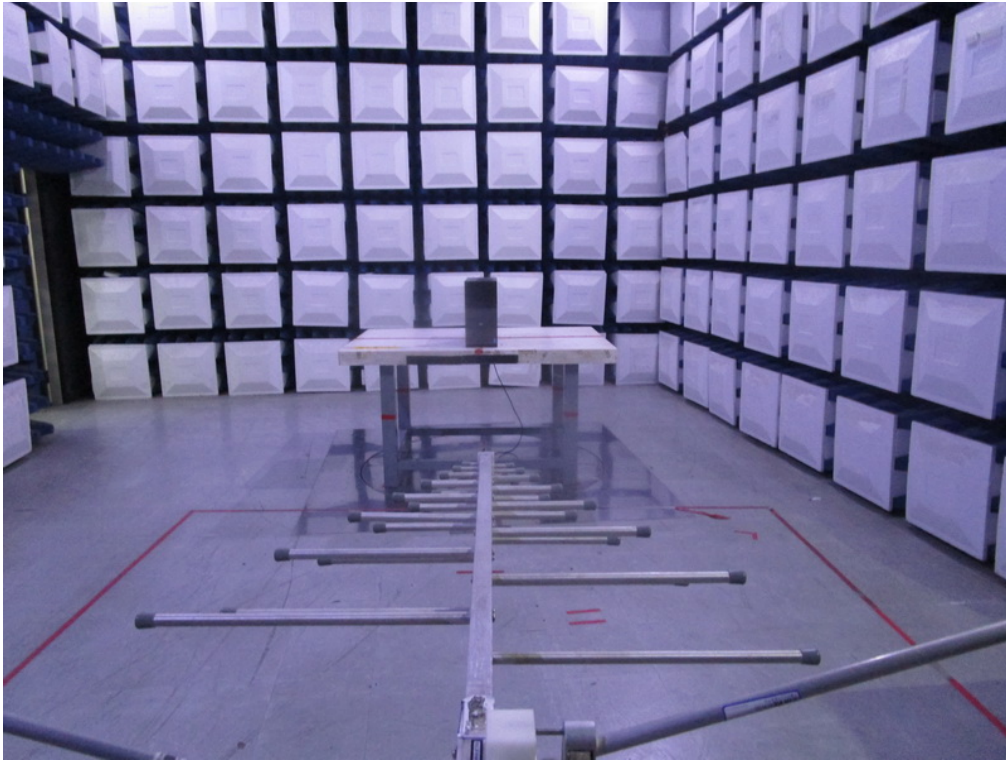
Radiated Emissions Test Photos**30 MHz to 1 GHz**

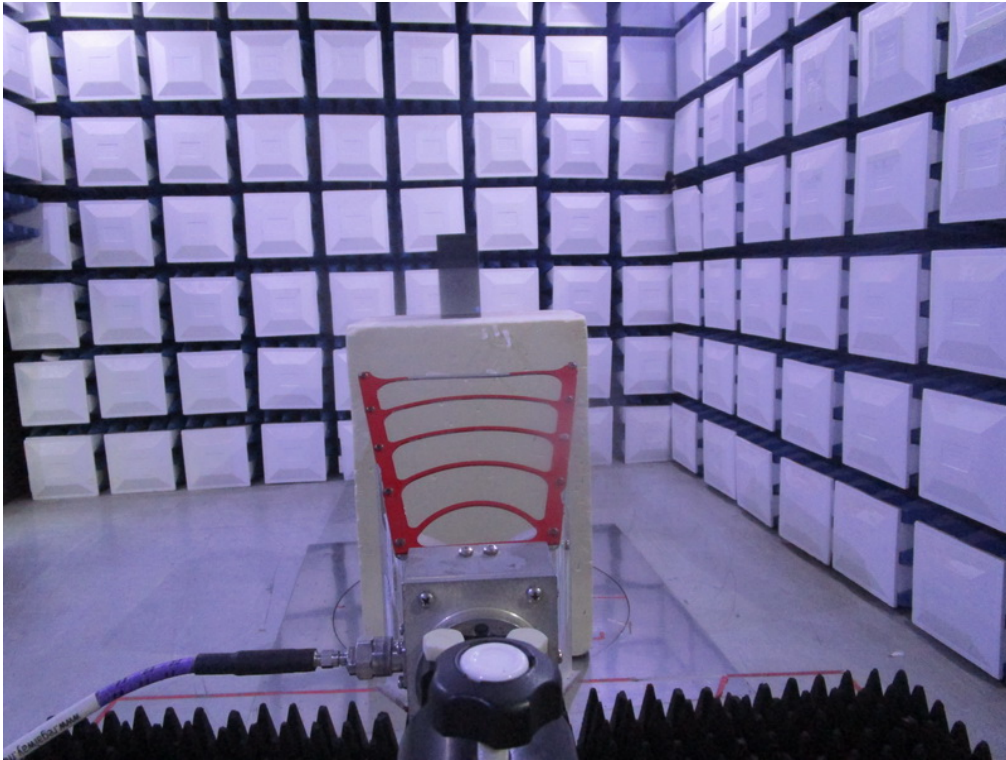
Radiated Emissions Test Photos**Above 1 GHz**

Conducted Test Photos



APPENDIX A - AC POWER LINE CONDUCTED EMISSIONS

Test Mode	TX A Mode Channel 40	Phase	Line
-----------	----------------------	-------	------

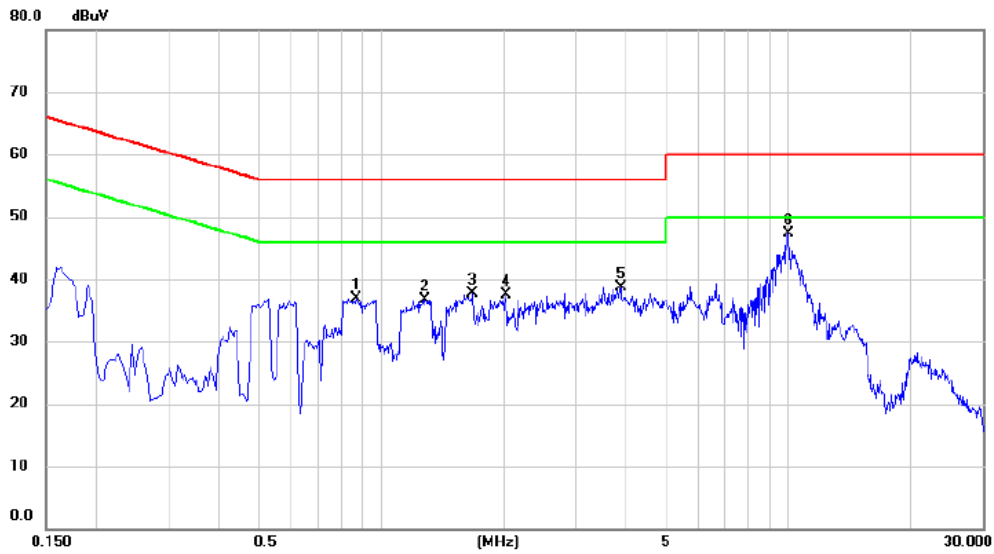

No. Mk.	Freq. MHz	Reading Level dBuV	Correct Factor dB	Measurement dBuV	Limit dBuV	Margin dB	Detector	Comment
1	0.8655	26.98	9.97	36.95	56.00	-19.05	peak	
2	1.2840	26.76	10.00	36.76	56.00	-19.24	peak	
3	1.6755	27.74	10.02	37.76	56.00	-18.24	peak	
4	2.0264	27.44	10.05	37.49	56.00	-18.51	peak	
5	3.8805	28.56	10.20	38.76	56.00	-17.24	peak	
6 *	9.9915	36.65	10.65	47.30	60.00	-12.70	peak	

REMARKS:

- (1) Measurement Value = Reading Level + Correct Factor.
- (2) Margin Level = Measurement Value - Limit Value.
- (3) The test result has included the cable loss.

Test Mode	TX A Mode Channel 40	Phase	Neutral
-----------	----------------------	-------	---------

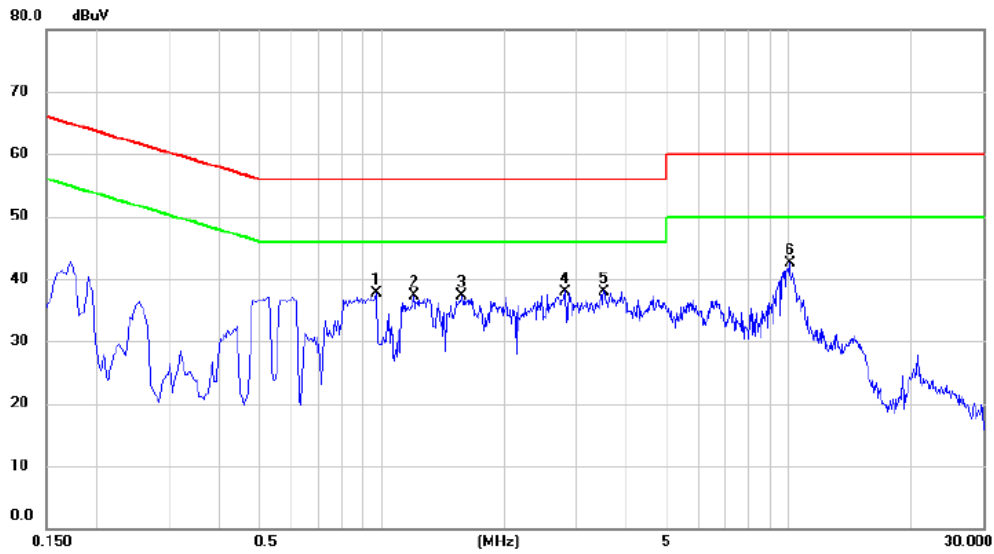

No.	Mk.	Freq. MHz	Reading Level dBuV	Correct Factor dB	Measure- ment dBuV	Limit dBuV	Margin dB	Detector	Comment
1		0.9690	27.47	10.26	37.73	56.00	-18.27	peak	
2		1.2030	27.00	10.29	37.29	56.00	-18.71	peak	
3		1.5765	26.94	10.33	37.27	56.00	-18.73	peak	
4		2.8184	27.54	10.46	38.00	56.00	-18.00	peak	
5		3.5250	27.48	10.52	38.00	56.00	-18.00	peak	
6	*	10.0680	31.45	11.02	42.47	60.00	-17.53	peak	

REMARKS:

- (1) Measurement Value = Reading Level + Correct Factor.
- (2) Margin Level = Measurement Value - Limit Value.
- (3) The test result has included the cable loss.

APPENDIX B - RADIATED EMISSION - 9 KHZ TO 30 MHZ

Test Mode	TX A Mode Channel 40	Polarization	Ant 0°
-----------	----------------------	--------------	--------

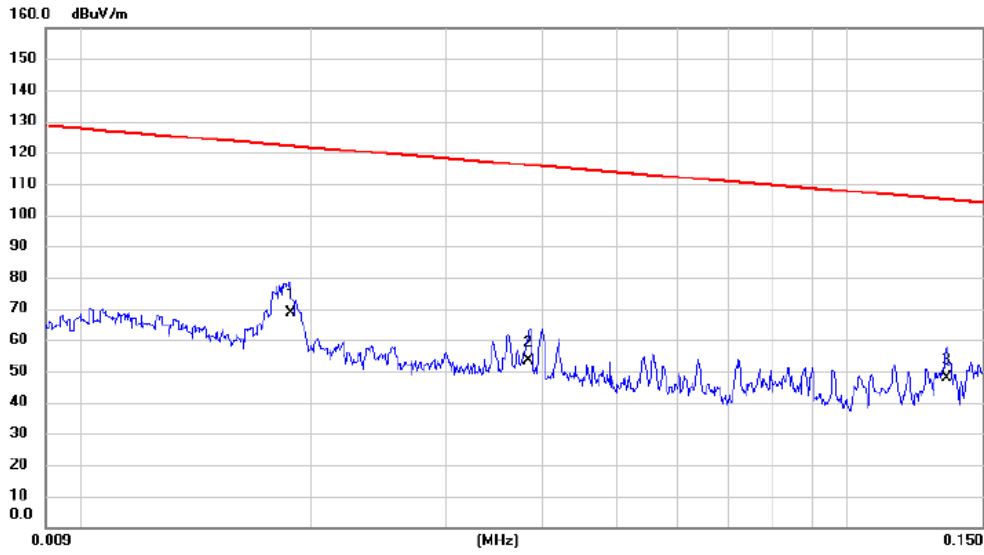

No. Mk.	Freq. MHz	Reading Level dBuV	Correct Factor dB	Measurement dBuV/m	Limit dBuV/m	Margin dB	Detector	Antenna Height cm	Table Degree	Comment
1 *	0.0188	55.05	13.59	68.64	122.12	-53.48	AVG			
2	0.0384	40.77	12.73	53.50	115.92	-62.42	AVG			
3	0.1348	35.03	12.73	47.76	105.01	-57.25	AVG			

REMARKS:

- (1) Measurement Value = Reading Level + Correct Factor.
- (2) Margin Level = Measurement Value - Limit Value.

Test Mode	TX A Mode Channel 40	Polarization	Ant 0°
-----------	----------------------	--------------	--------

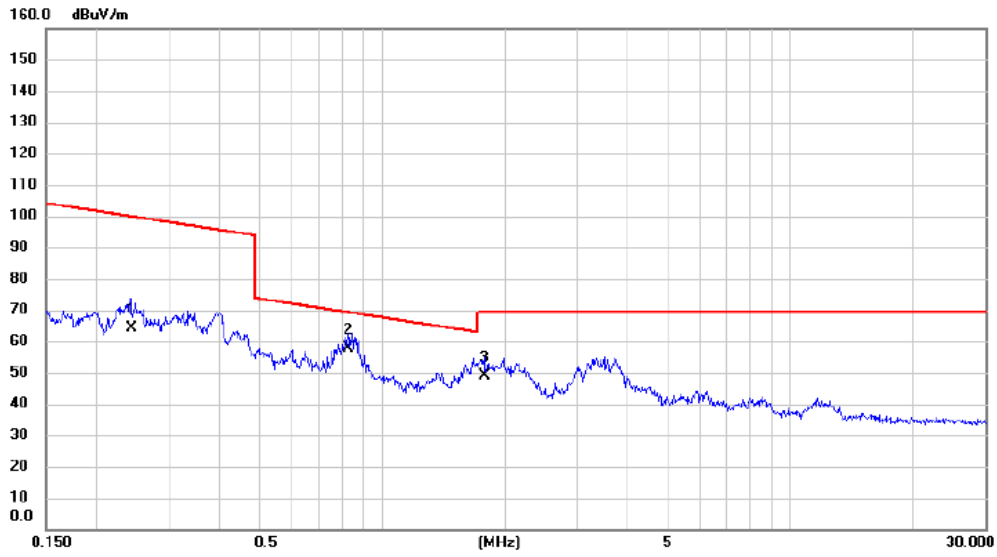

No. Mk.	Freq. MHz	Reading Level dBuV	Correct Factor dB	Measurement dBuV/m	Limit dBuV/m	Margin dB	Detector	Antenna Height cm	Table Degree	Comment
1	0.2430	51.62	12.66	64.28	99.89	-35.61	AVG			
2 *	0.8261	45.88	11.87	57.75	69.26	-11.51	QP			
3	1.7810	37.58	11.41	48.99	69.54	-20.55	QP			

REMARKS:

- (1) Measurement Value = Reading Level + Correct Factor.
- (2) Margin Level = Measurement Value - Limit Value.

Test Mode	TX A Mode Channel 40	Polarization	Ant 90°
-----------	----------------------	--------------	---------

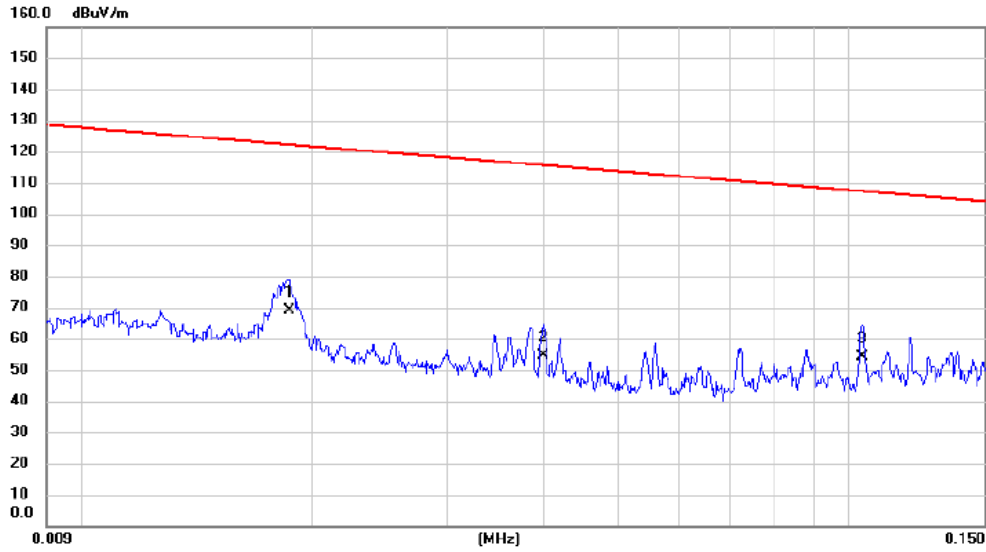

No.	Mk.	Freq.	Reading Level	Correct Factor	Measurement	Limit	Margin	Antenna Height	Table Degree	
		MHz	dBuV	dB	dBuV/m	dBuV/m	dB	cm	degree	Comment
1	*	0.0187	55.57	13.62	69.19	122.17	-52.98	AVG		
2		0.0400	41.72	12.69	54.41	115.56	-61.15	AVG		
3		0.1041	41.33	12.72	54.05	107.26	-53.21	AVG		

REMARKS:

- (1) Measurement Value = Reading Level + Correct Factor.
- (2) Margin Level = Measurement Value - Limit Value.

Test Mode	TX A Mode Channel 40	Polarization	Ant 90°
-----------	----------------------	--------------	---------

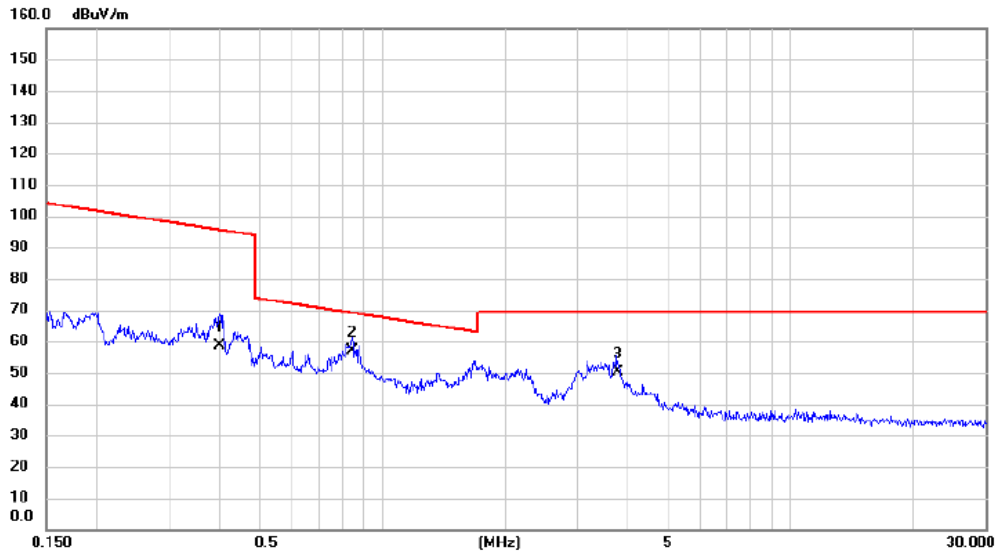

No. Mk.	Freq. MHz	Reading Level dBuV	Correct Factor dB	Measure- ment dBuV/m	Limit dBuV/m	Margin dB	Detector	Antenna Height cm	Table Degree	Comment
1	0.3997	46.42	12.26	58.68	95.57	-36.89	AVG			
2 *	0.8438	45.25	11.86	57.11	69.08	-11.97	QP			
3	3.7594	39.35	10.91	50.26	69.54	-19.28	QP			

REMARKS:

- (1) Measurement Value = Reading Level + Correct Factor.
- (2) Margin Level = Measurement Value - Limit Value.

APPENDIX C - RADIATED EMISSION - 30 MHZ TO 1 GHZ

Orthogonal Axis	X
Test Mode:	TX A MODE CHANNEL 40

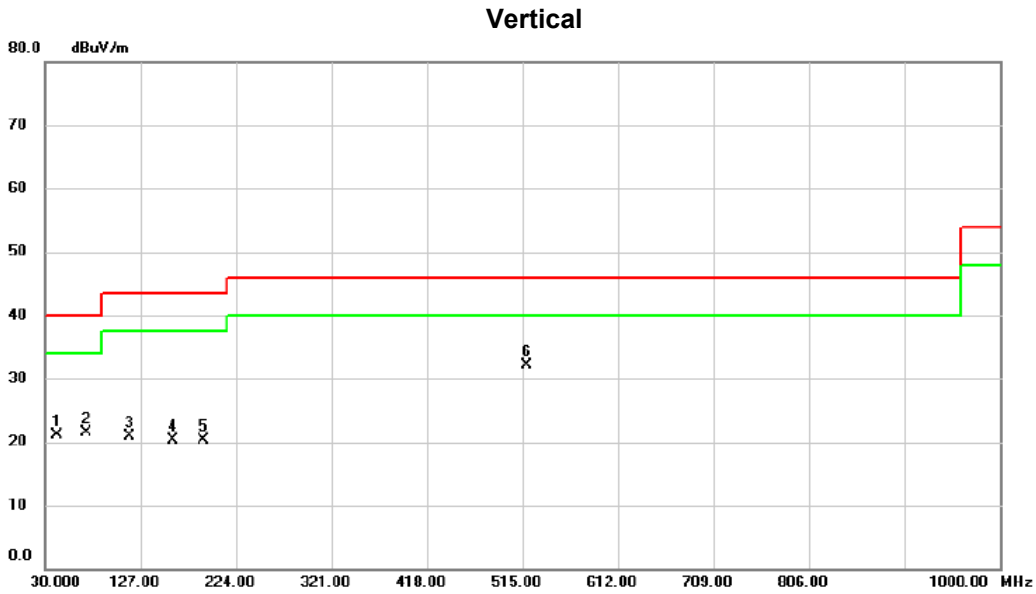

No.	Mk.	Freq. MHz	Reading Level dBuV	Correct Factor dB	Measure- ment dBuV/m	Limit dBuV/m	Margin dB	Detector	Comment
1		42.610	35.32	-14.18	21.14	40.00	-18.86	peak	
2		71.710	37.83	-16.23	21.60	40.00	-18.40	peak	
3		115.360	34.31	-13.43	20.88	43.50	-22.62	peak	
4		159.980	31.01	-10.67	20.34	43.50	-23.16	peak	
5		191.020	34.45	-14.16	20.29	43.50	-23.21	peak	
6	*	519.850	39.16	-7.08	32.08	46.00	-13.92	peak	

REMARKS:

- (1) Measurement Value = Reading Level + Correct Factor.
- (2) Margin Level = Measurement Value - Limit Value.

Orthogonal Axis	X
Test Mode:	TX A MODE CHANNEL 40

Horizontal

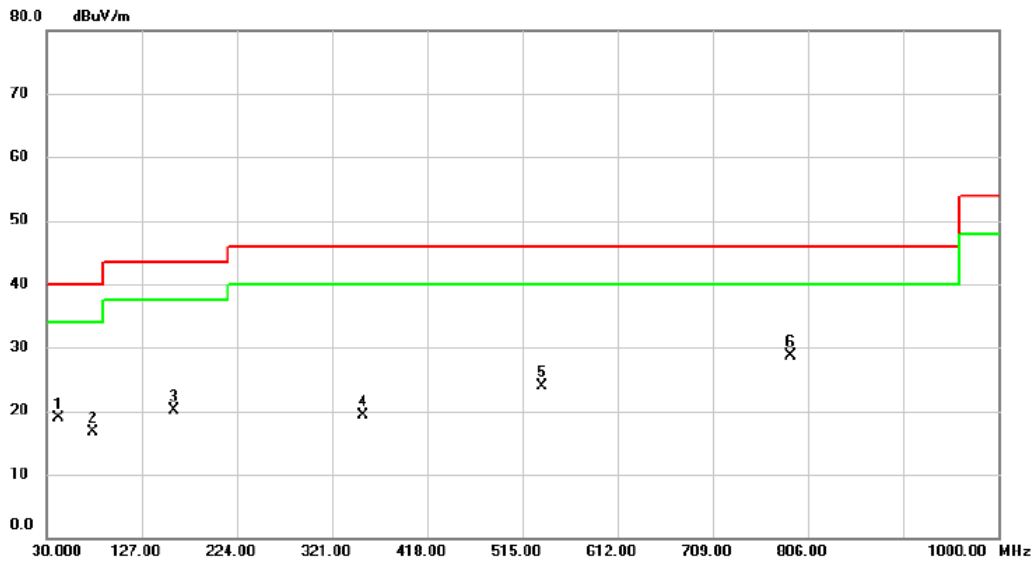

No.	Mk.	Freq. MHz	Reading Level dBuV	Correct Factor dB	Measure- ment dBuV/m	Limit dBuV/m	Margin dB	Detector	Comment
1		42.610	33.12	-14.18	18.94	40.00	-21.06	peak	
2		77.530	33.90	-17.29	16.61	40.00	-23.39	peak	
3		159.980	30.79	-10.67	20.12	43.50	-23.38	peak	
4		352.040	29.37	-10.16	19.21	46.00	-26.79	peak	
5		535.370	30.84	-6.94	23.90	46.00	-22.10	peak	
6	*	788.540	31.39	-2.68	28.71	46.00	-17.29	peak	

REMARKS:

- (1) Measurement Value = Reading Level + Correct Factor.
- (2) Margin Level = Measurement Value - Limit Value.

APPENDIX D - RADIATED EMISSION - ABOVE 1000 MHZ

Orthogonal Axis	X
Test Mode	UNII-1_TX A Mode 5180 MHz

Vertical

130 dBuV/m

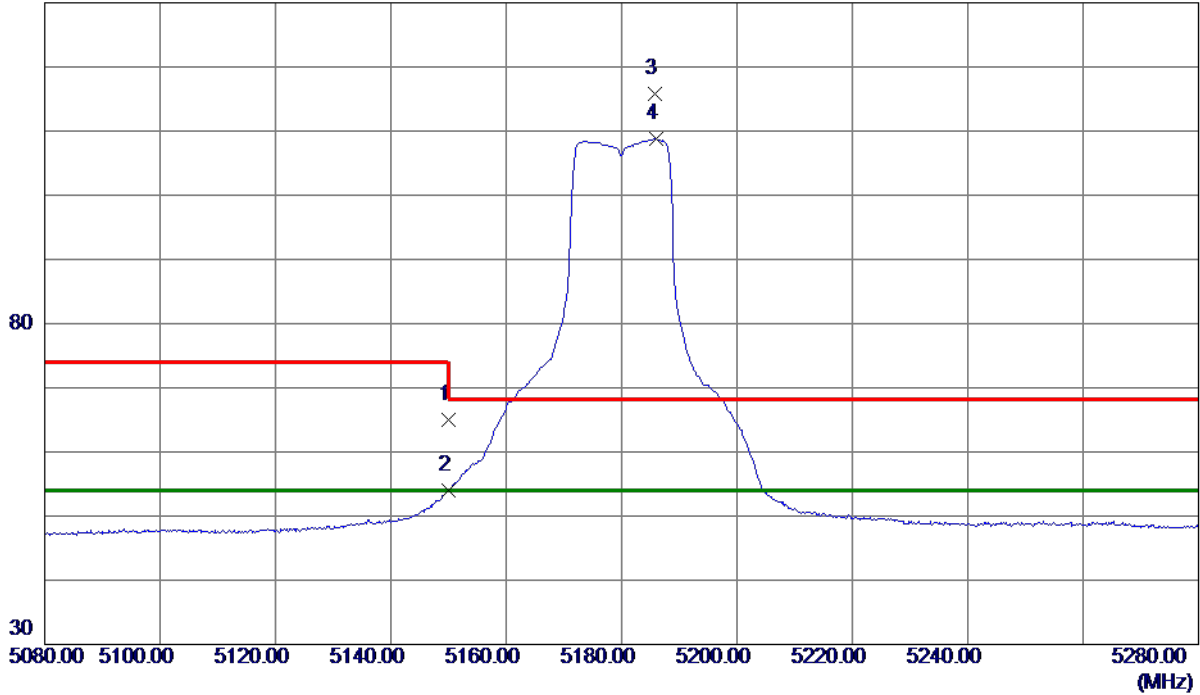

No.	Freq. MHz	Reading Level dBuV/m	Correct Factor dB	Measure ment dBuV/m	Limit dBuV/m	Margin dB	Detector	Comment
1	5150.0000	49.71	15.26	64.97	74.00	-9.03	Peak	
2	5150.0000	38.69	15.26	53.95	54.00	-0.05	AVG	
3	5185.8000	100.47	15.35	115.82	68.30	47.52	Peak	No Limit
4 *	5185.9000	93.45	15.35	108.80	54.00	54.80	AVG	No Limit

REMARKS:

- (1) Measurement Value = Reading Level + Correct Factor.
- (2) Margin Level = Measurement Value - Limit Value.

Orthogonal Axis	X
Test Mode	UNII-1_TX A Mode 5180 MHz

Vertical

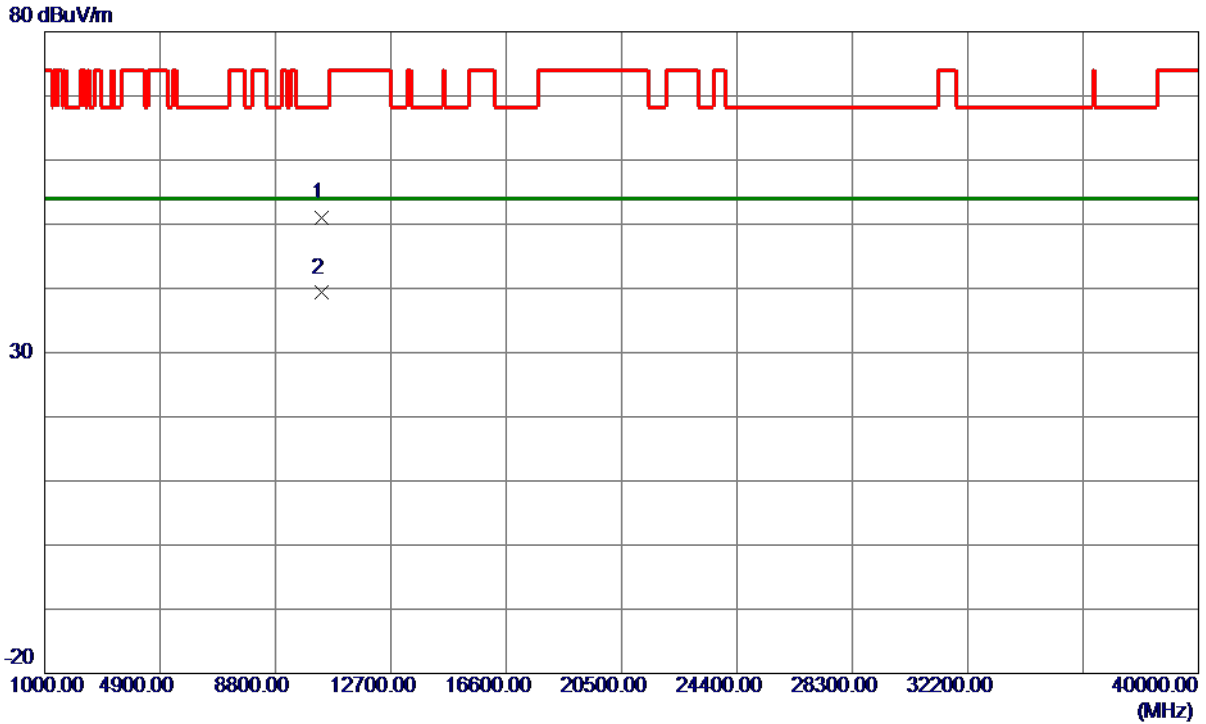

No.	Freq. MHz	Reading Level dBuV/m	Correct Factor dB	Measure ment dBuV/m	Limit dBuV/m	Margin dB	Detector	Comment
1	10352.6800	38.63	12.28	50.91	68.30	-17.39	Peak	
2 *	10356.2600	27.02	12.28	39.30	54.00	-14.70	AVG	

REMARKS:

- (1) Measurement Value = Reading Level + Correct Factor.
- (2) Margin Level = Measurement Value - Limit Value.

Orthogonal Axis	X
Test Mode	UNII-1_TX A Mode 5180 MHz

Horizontal

130 dBuV/m

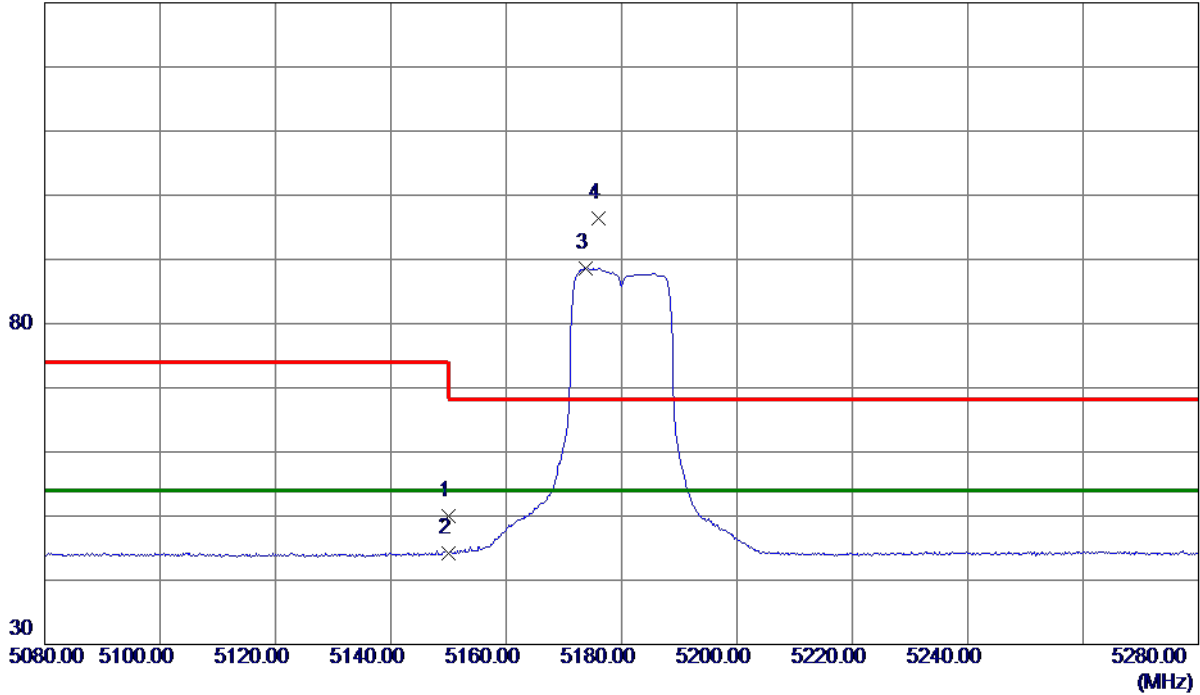

No.	Freq. MHz	Reading Level dBuV/m	Correct Factor dB	Measure ment dBuV/m	Limit dBuV/m	Margin dB	Detector	Comment
1	5150.0000	34.75	15.26	50.01	74.00	-23.99	Peak	
2	5150.0000	28.93	15.26	44.19	54.00	-9.81	AVG	
3 *	5173.8000	73.25	15.32	88.57	54.00	34.57	AVG	No Limit
4	5176.0000	81.13	15.32	96.45	68.30	28.15	Peak	No Limit

REMARKS:

- (1) Measurement Value = Reading Level + Correct Factor.
- (2) Margin Level = Measurement Value - Limit Value.

Orthogonal Axis	X
Test Mode	UNII-1_TX A Mode 5180 MHz

Horizontal

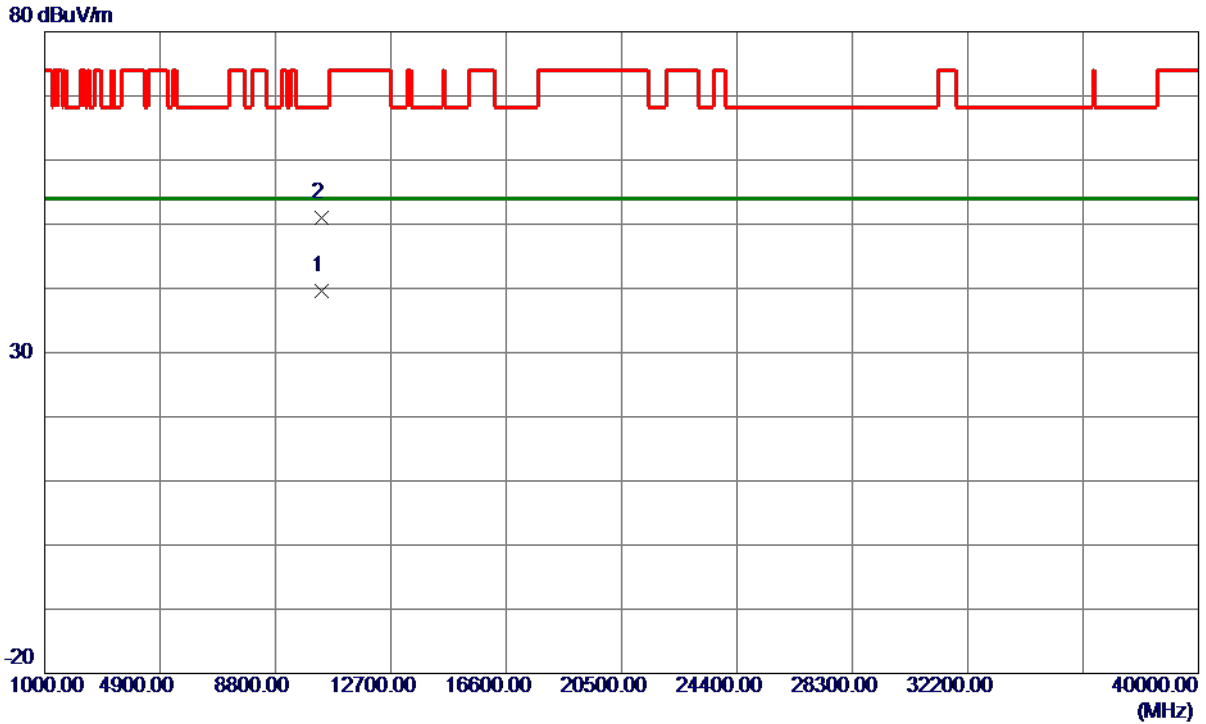

No.	Freq. MHz	Reading Level dBuV/m	Correct Factor dB	Measure ment dBuV/m	Limit dBuV/m	Margin dB	Detector	Comment
1 *	10354.4000	27.29	12.28	39.57	54.00	-14.43	AVG	
2	10369.8000	38.69	12.29	50.98	68.30	-17.32	Peak	

REMARKS:

- (1) Measurement Value = Reading Level + Correct Factor.
- (2) Margin Level = Measurement Value - Limit Value.

Orthogonal Axis	X
Test Mode	UNII-1_TX A Mode 5200 MHz

Vertical

130 dBuV/m

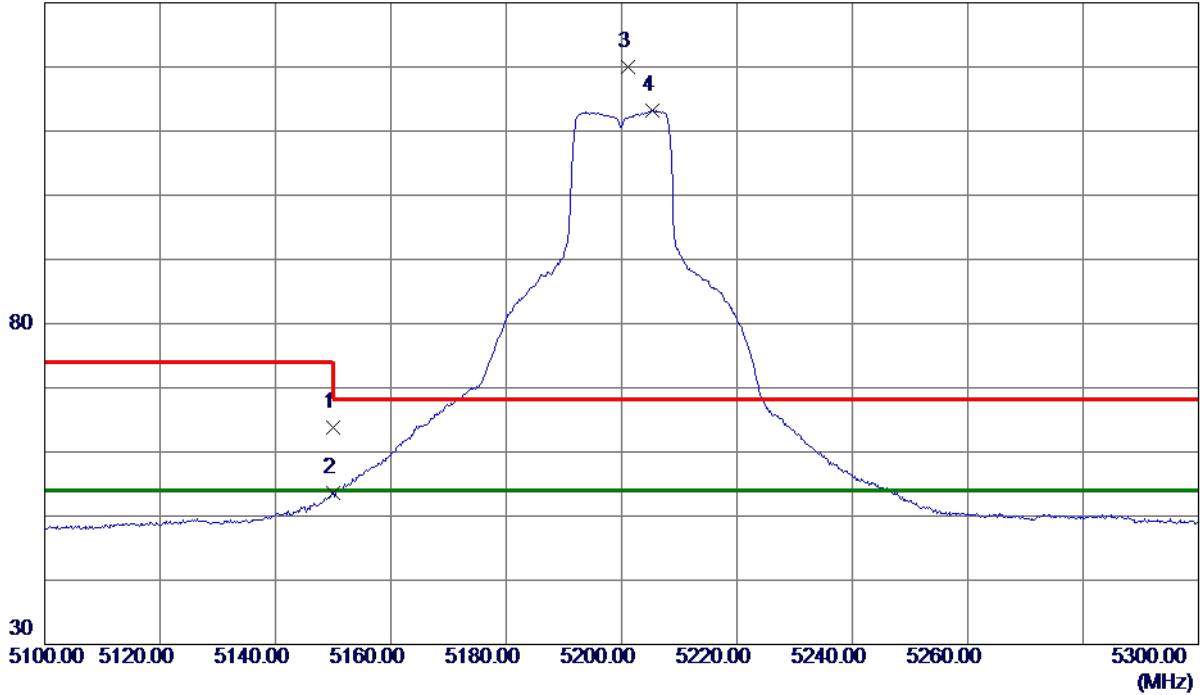

No.	Freq. MHz	Reading Level dBuV/m	Correct Factor dB	Measure ment dBuV/m	Limit dBuV/m	Margin dB	Detector	Comment
1	5150.0000	48.53	15.26	63.79	74.00	-10.21	Peak	
2	5150.0000	38.38	15.26	53.64	54.00	-0.36	AVG	
3	5201.1000	104.61	15.38	119.99	68.30	51.69	Peak	No Limit
4 *	5205.3000	97.80	15.39	113.19	54.00	59.19	AVG	No Limit

REMARKS:

- (1) Measurement Value = Reading Level + Correct Factor.
- (2) Margin Level = Measurement Value - Limit Value.

Orthogonal Axis	X
Test Mode	UNII-1_TX A Mode 5200 MHz

Vertical

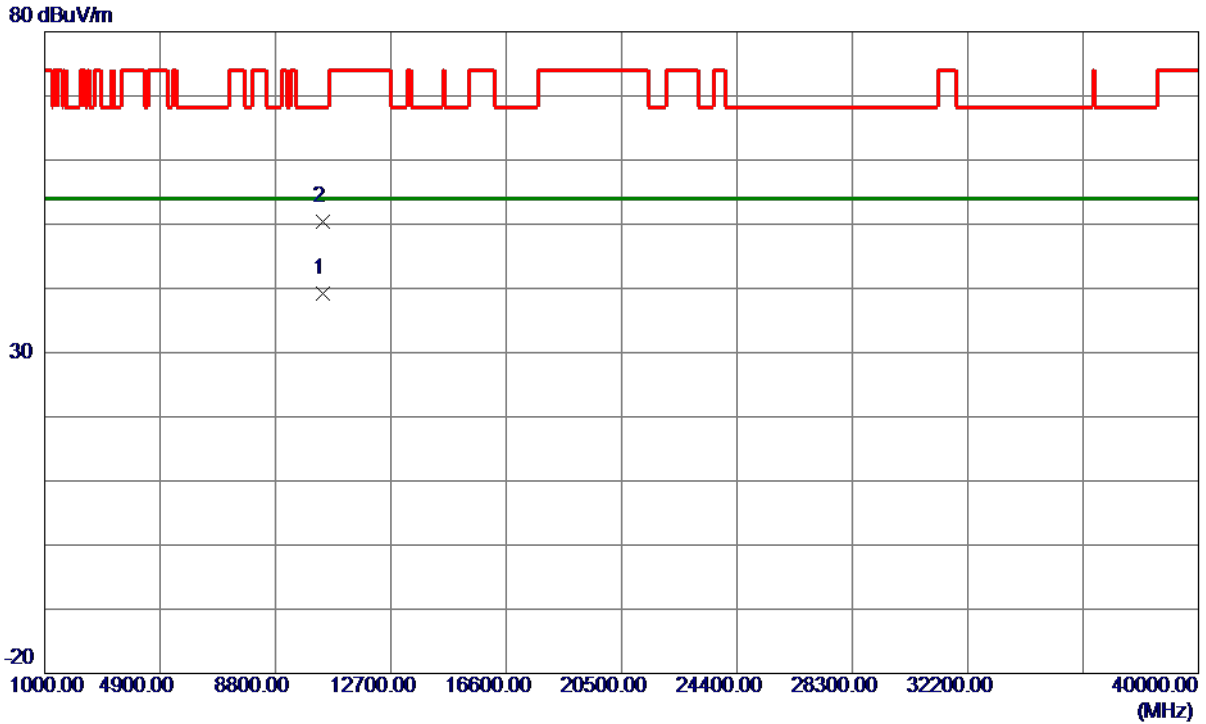

No.	Freq. MHz	Reading Level dBuV/m	Correct Factor dB	Measure ment dBuV/m	Limit dBuV/m	Margin dB	Detector	Comment
1 *	10404.7600	26.83	12.31	39.14	54.00	-14.86	AVG	
2	10405.5400	38.11	12.32	50.43	68.30	-17.87	Peak	

REMARKS:

- (1) Measurement Value = Reading Level + Correct Factor.
- (2) Margin Level = Measurement Value - Limit Value.

Orthogonal Axis	X
Test Mode	UNII-1_TX A Mode 5200 MHz

Horizontal

130 dBuV/m

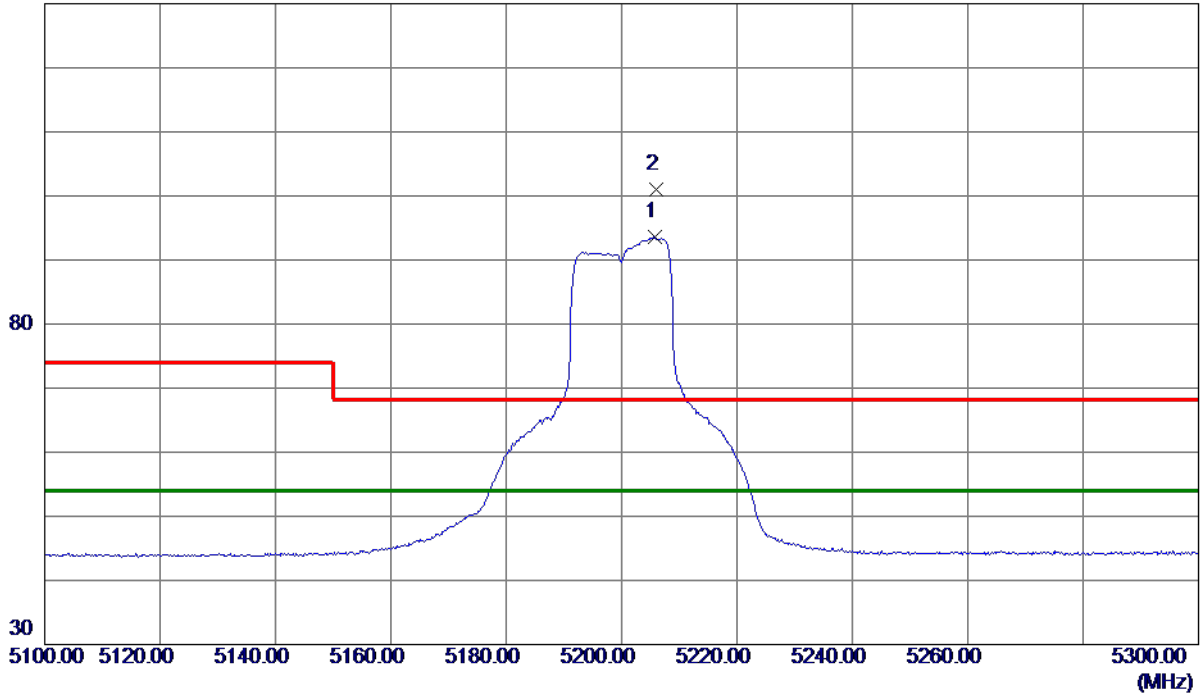

No.	Freq. MHz	Reading Level dBuV/m	Correct Factor dB	Measure ment dBuV/m	Limit dBuV/m	Margin dB	Detector	Comment
1 *	5205.8000	78.15	15.39	93.54	54.00	39.54	AVG	No Limit
2	5206.0000	85.51	15.39	100.90	68.30	32.60	Peak	No Limit

REMARKS:

- (1) Measurement Value = Reading Level + Correct Factor.
- (2) Margin Level = Measurement Value - Limit Value.

Orthogonal Axis	X
Test Mode	UNII-1_TX A Mode 5200 MHz

Horizontal

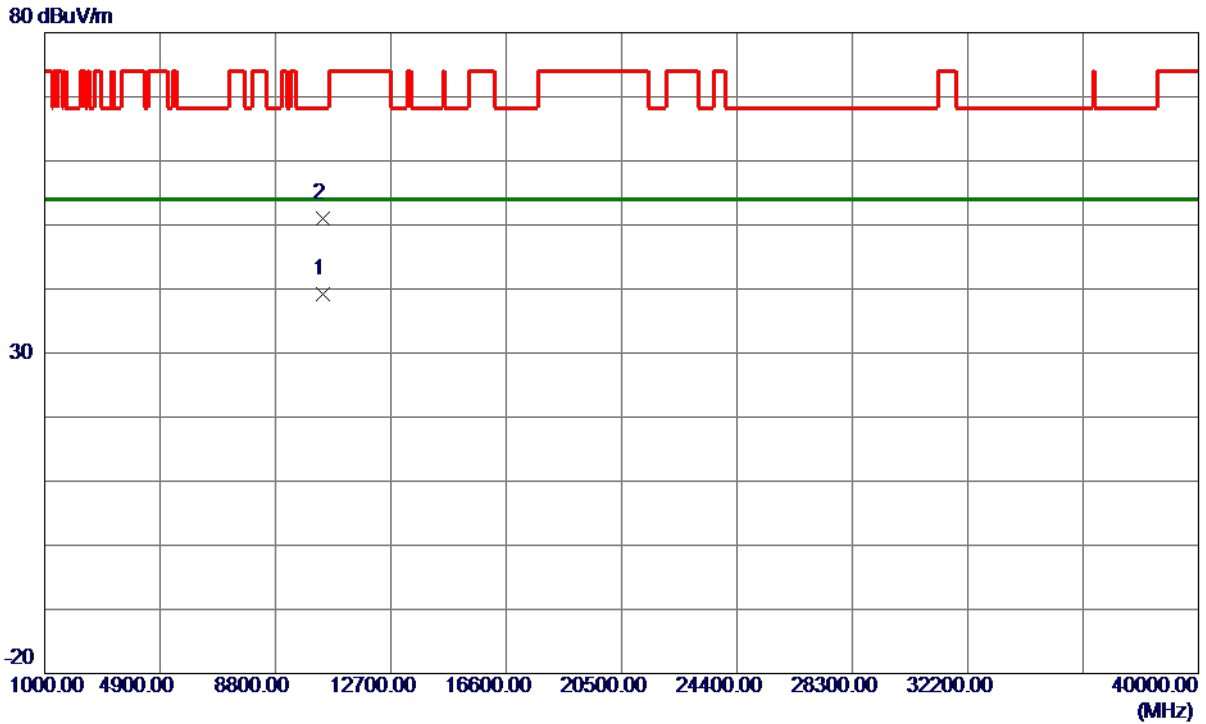

No.	Freq. MHz	Reading Level dBuV/m	Correct Factor dB	Measure ment dBuV/m	Limit dBuV/m	Margin dB	Detector	Comment
1 *	10393.0400	26.93	12.31	39.24	54.00	-14.76	AVG	
2	10394.6000	38.77	12.31	51.08	68.30	-17.22	Peak	

REMARKS:

- (1) Measurement Value = Reading Level + Correct Factor.
- (2) Margin Level = Measurement Value - Limit Value.

Orthogonal Axis	X
Test Mode	UNII-1_TX A Mode 5240 MHz

Vertical

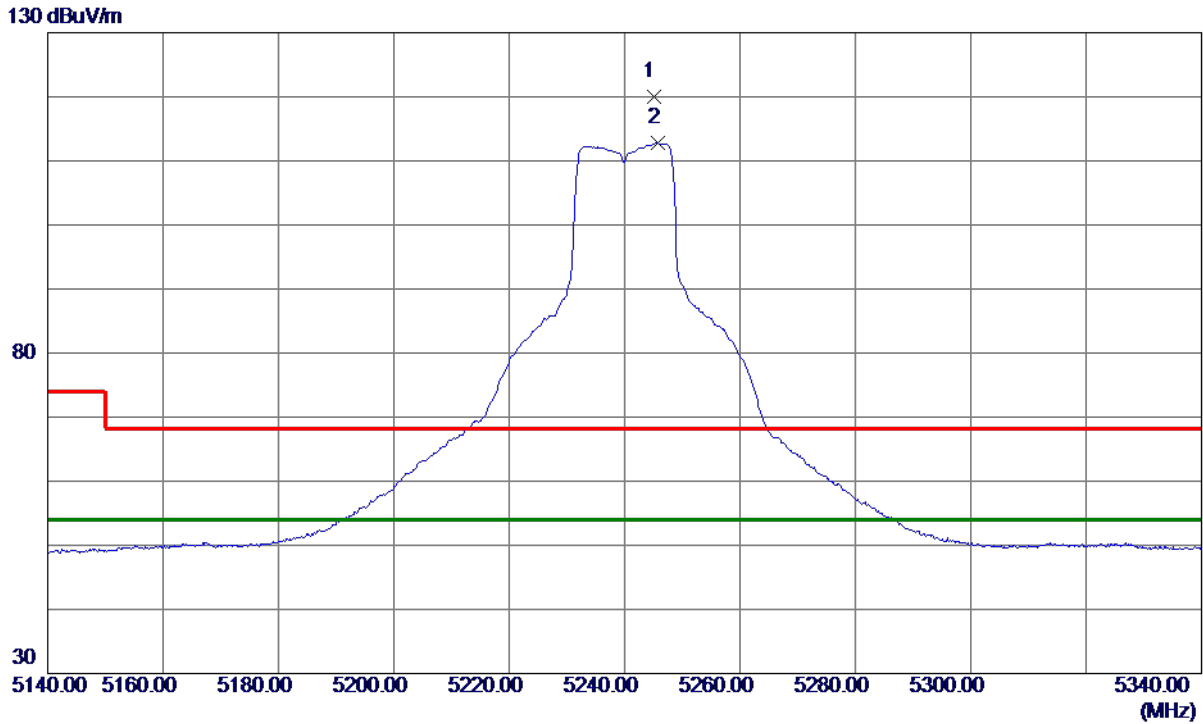

No.	Freq. MHz	Reading Level dBuV/m	Correct Factor dB	Measure ment dBuV/m	Limit dBuV/m	Margin dB	Detector	Comment
1	5245.0000	104.45	15.48	119.93	68.30	51.63	Peak	No Limit
2 *	5245.8000	97.38	15.48	112.86	54.00	58.86	AVG	No Limit

REMARKS:

- (1) Measurement Value = Reading Level + Correct Factor.
- (2) Margin Level = Measurement Value - Limit Value.

Orthogonal Axis	X
Test Mode	UNII-1_TX A Mode 5240 MHz

Vertical

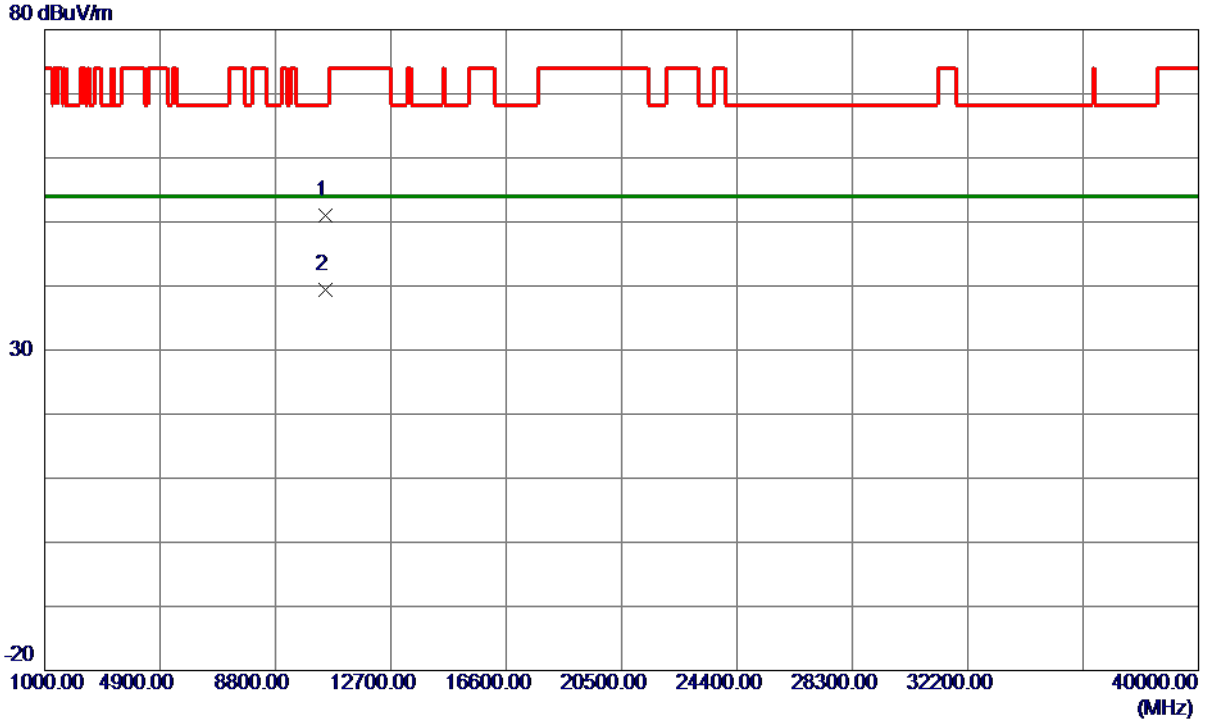

No.	Freq. MHz	Reading Level dBuV/m	Correct Factor dB	Measure ment dBuV/m	Limit dBuV/m	Margin dB	Detector	Comment
1	10483.1800	38.60	12.36	50.96	68.30	-17.34	Peak	
2 *	10489.5199	27.11	12.37	39.48	54.00	-14.52	AVG	

REMARKS:

- (1) Measurement Value = Reading Level + Correct Factor.
- (2) Margin Level = Measurement Value - Limit Value.

Orthogonal Axis	X
Test Mode	UNII-1_TX A Mode 5240 MHz

Horizontal

130 dBuV/m

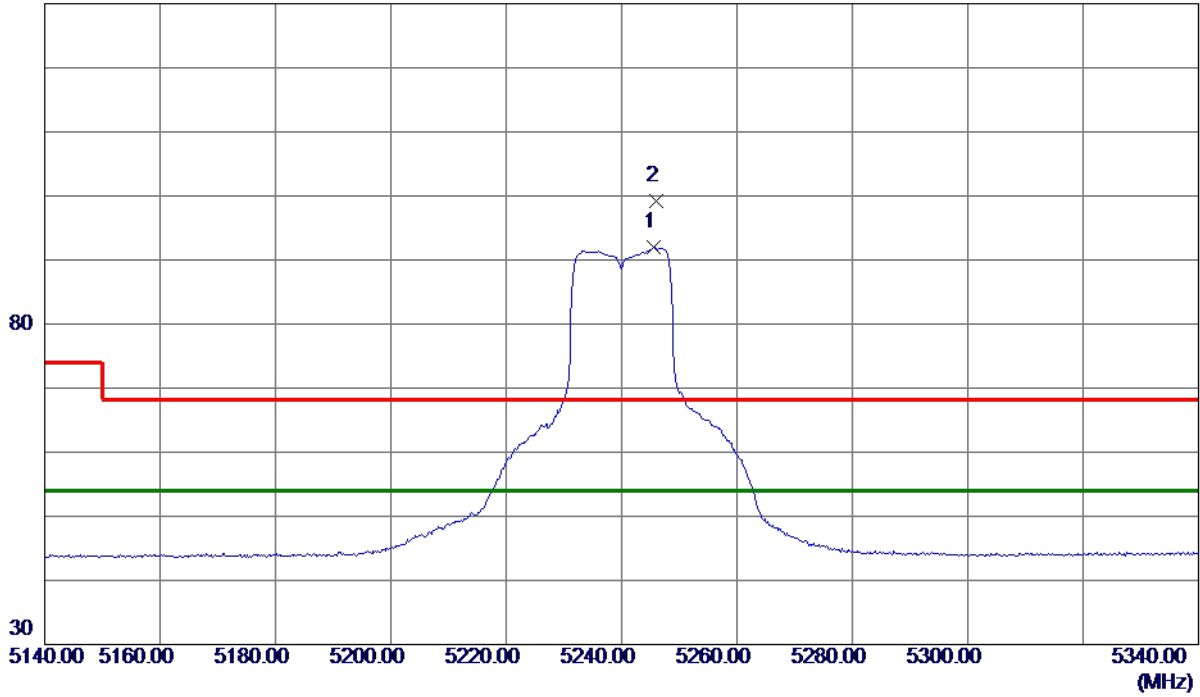

No.	Freq. MHz	Reading Level dBuV/m	Correct Factor dB	Measure ment dBuV/m	Limit dBuV/m	Margin dB	Detector	Comment
1 *	5245.6000	76.44	15.48	91.92	54.00	37.92	AVG	No Limit
2	5246.0000	83.77	15.48	99.25	68.30	30.95	Peak	No Limit

REMARKS:

- (1) Measurement Value = Reading Level + Correct Factor.
- (2) Margin Level = Measurement Value - Limit Value.

Orthogonal Axis	X
Test Mode	UNII-1_TX A Mode 5240 MHz

Horizontal

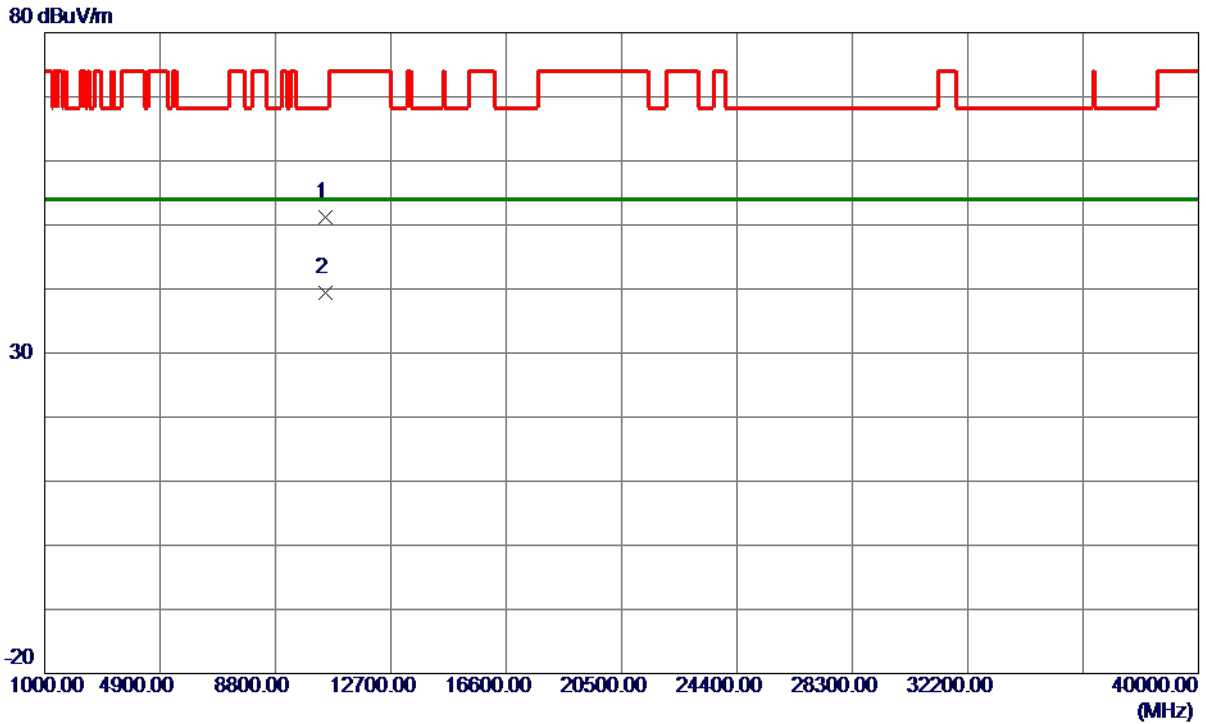

No.	Freq. MHz	Reading Level dBuV/m	Correct Factor dB	Measure ment dBuV/m	Limit dBuV/m	Margin dB	Detector	Comment
1	10478.6600	38.82	12.36	51.18	68.30	-17.12	Peak	
2 *	10489.8200	27.12	12.37	39.49	54.00	-14.51	AVG	

REMARKS:

- (1) Measurement Value = Reading Level + Correct Factor.
- (2) Margin Level = Measurement Value - Limit Value.

Orthogonal Axis	X
Test Mode	UNII-2A_TX A Mode 5260 MHz

Vertical

130 dBuV/m

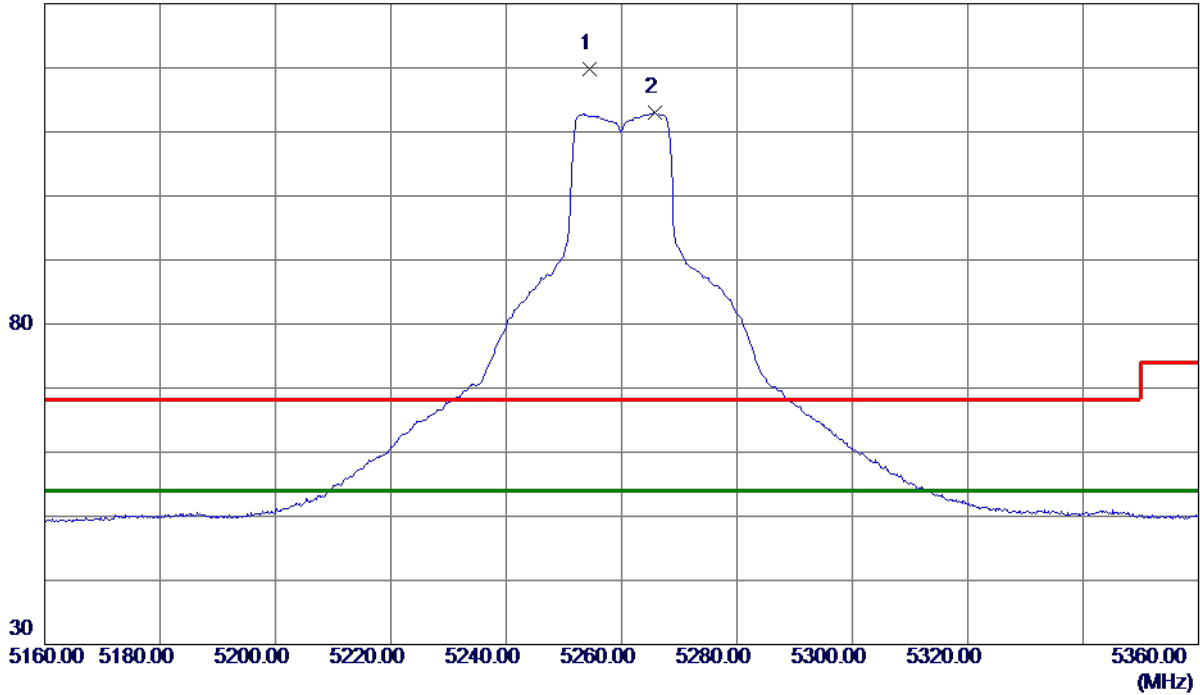

No.	Freq. MHz	Reading Level dBuV/m	Correct Factor dB	Measure ment dBuV/m	Limit dBuV/m	Margin dB	Detector	Comment
1	5254.4000	104.21	15.50	119.71	68.30	51.41	Peak	No Limit
2 *	5265.7000	97.44	15.53	112.97	54.00	58.97	AVG	No Limit

REMARKS:

- (1) Measurement Value = Reading Level + Correct Factor.
- (2) Margin Level = Measurement Value - Limit Value.

Orthogonal Axis	X
Test Mode	UNII-2A_TX A Mode 5260 MHz

Vertical

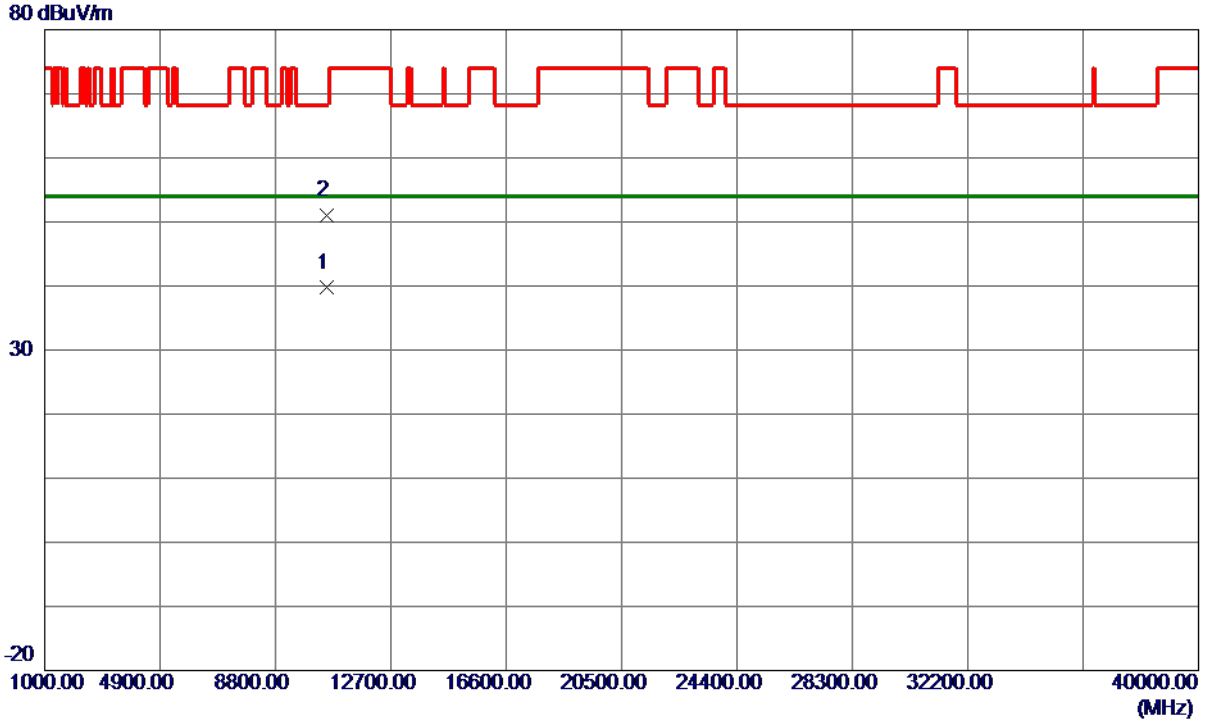

No.	Freq. MHz	Reading Level dBuV/m	Correct Factor dB	Measure ment dBuV/m	Limit dBuV/m	Margin dB	Detector	Comment
1 *	10513.2000	27.31	12.39	39.70	54.00	-14.30	AVG	
2	10514.7800	38.69	12.39	51.08	68.30	-17.22	Peak	

REMARKS:

- (1) Measurement Value = Reading Level + Correct Factor.
- (2) Margin Level = Measurement Value - Limit Value.

Orthogonal Axis	X
Test Mode	UNII-2A_TX A Mode 5260 MHz

Horizontal

130 dBuV/m

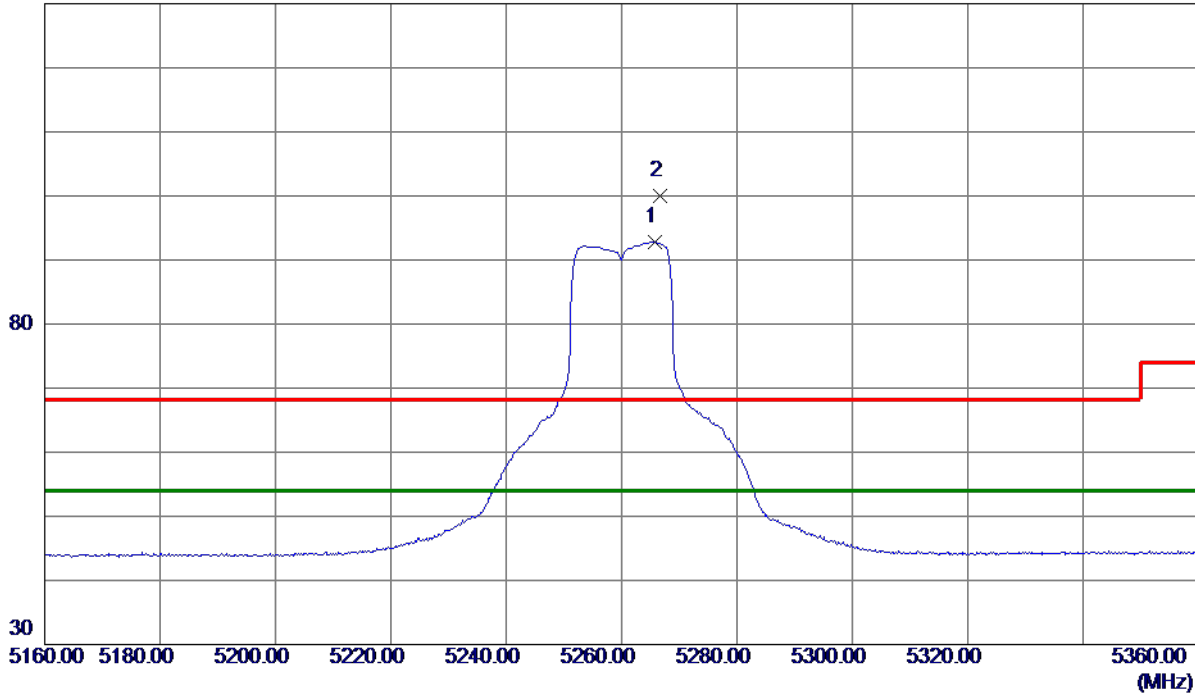

No.	Freq. MHz	Reading Level dBuV/m	Correct Factor dB	Measure ment dBuV/m	Limit dBuV/m	Margin dB	Detector	Comment
1 *	5265.8000	77.31	15.53	92.84	54.00	38.84	AVG	No Limit
2	5266.6000	84.47	15.53	100.00	68.30	31.70	Peak	No Limit

REMARKS:

- (1) Measurement Value = Reading Level + Correct Factor.
- (2) Margin Level = Measurement Value - Limit Value.

Orthogonal Axis	X
Test Mode	UNII-2A_TX A Mode 5260 MHz

Horizontal

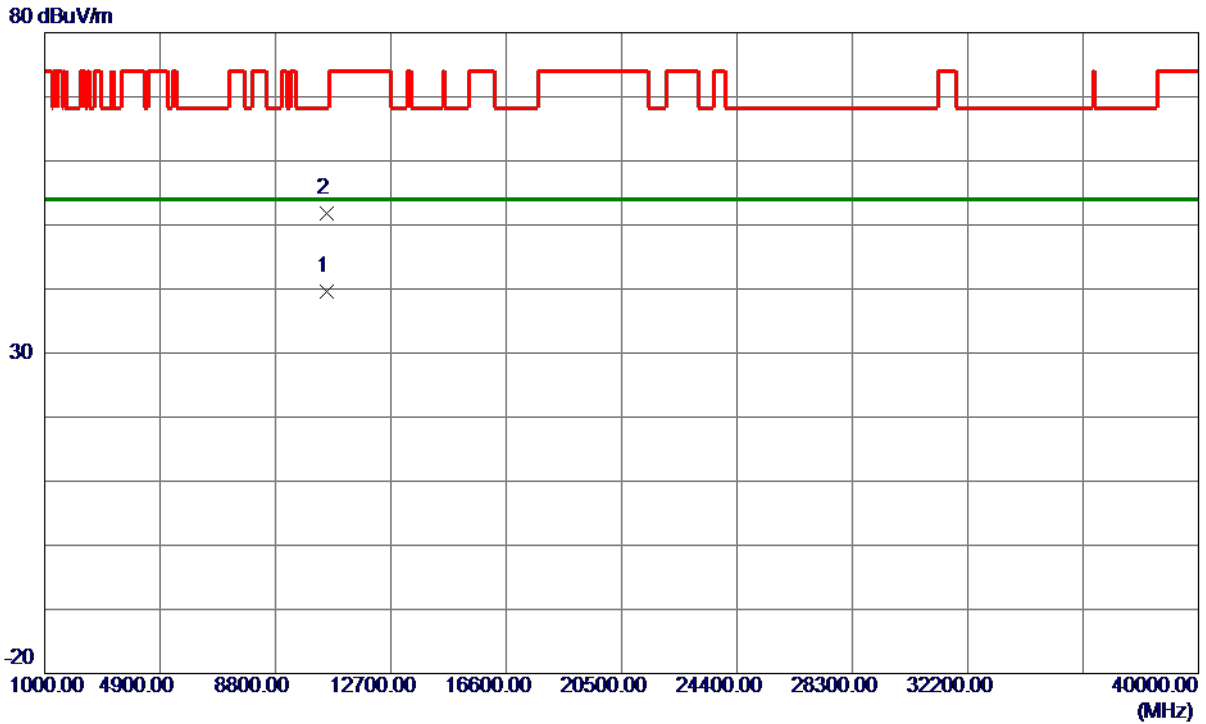

No.	Freq. MHz	Reading Level dBuV/m	Correct Factor dB	Measure ment dBuV/m	Limit dBuV/m	Margin dB	Detector	Comment
1 *	10517.0599	27.30	12.39	39.69	54.00	-14.31	AVG	
2	10520.8200	39.44	12.39	51.83	68.30	-16.47	Peak	

REMARKS:

- (1) Measurement Value = Reading Level + Correct Factor.
- (2) Margin Level = Measurement Value - Limit Value.

Orthogonal Axis	X
Test Mode	UNII-2A_TX A Mode 5300 MHz

Vertical

130 dBuV/m

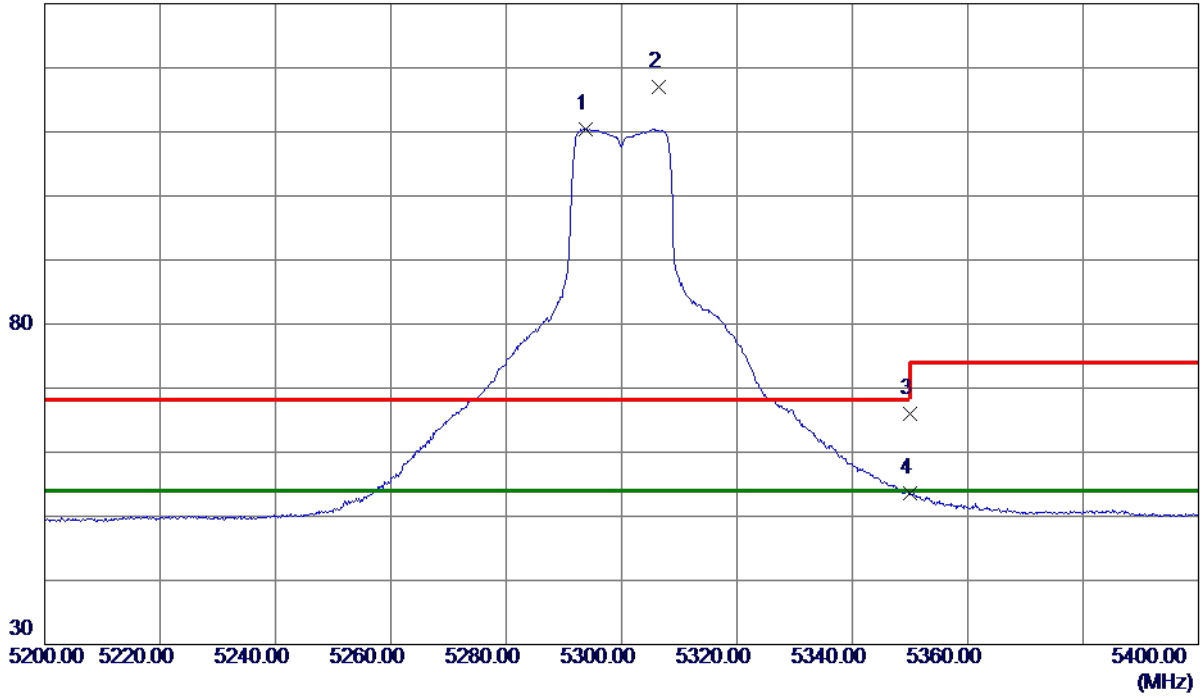

No.	Freq. MHz	Reading Level dBuV/m	Correct Factor dB	Measure ment dBuV/m	Limit dBuV/m	Margin dB	Detector	Comment
1 *	5293.7000	94.86	15.59	110.45	54.00	56.45	AVG	No Limit
2	5306.5000	101.38	15.62	117.00	68.30	48.70	Peak	No Limit
3	5350.0000	50.36	15.72	66.08	74.00	-7.92	Peak	
4	5350.0000	37.82	15.72	53.54	54.00	-0.46	AVG	

REMARKS:

- (1) Measurement Value = Reading Level + Correct Factor.
- (2) Margin Level = Measurement Value - Limit Value.

Orthogonal Axis	X
Test Mode	UNII-2A_TX A Mode 5300 MHz

Vertical

80 dBuV/m

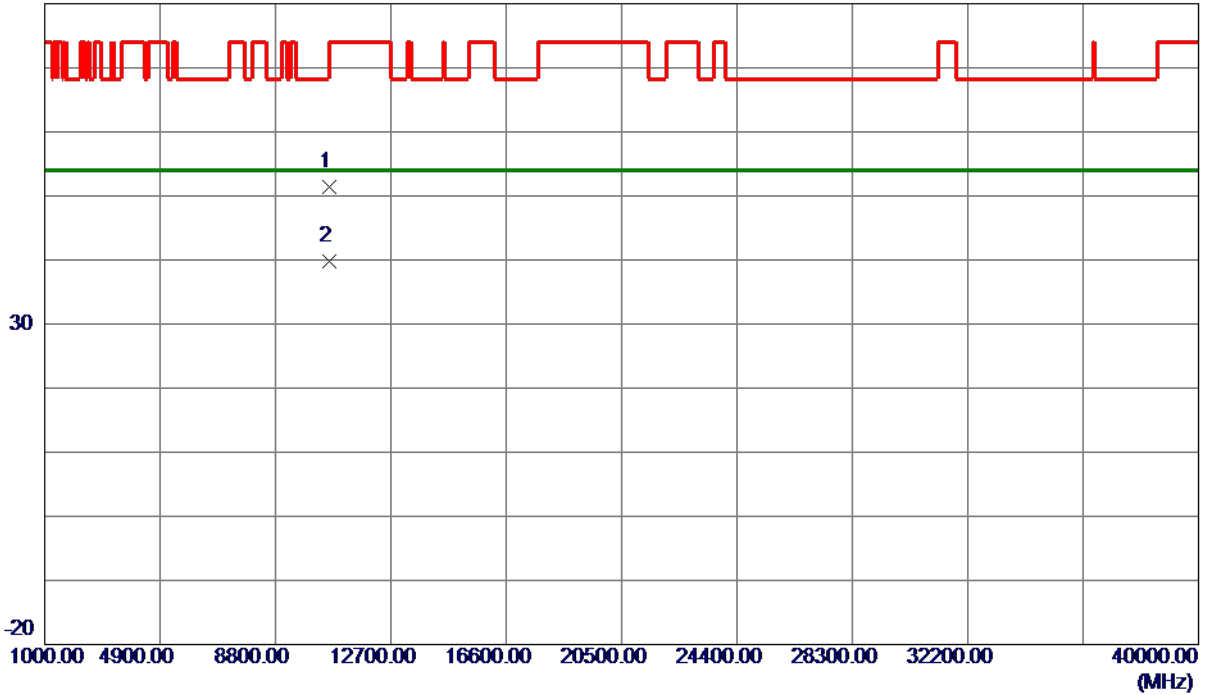

No.	Freq. MHz	Reading Level dBuV/m	Correct Factor dB	Measure ment dBuV/m	Limit dBuV/m	Margin dB	Detector	Comment
1	10598.4400	38.91	12.45	51.36	68.30	-16.94	Peak	
2 *	10609.3600	27.42	12.46	39.88	54.00	-14.12	AVG	

REMARKS:

- (1) Measurement Value = Reading Level + Correct Factor.
- (2) Margin Level = Measurement Value - Limit Value.

Orthogonal Axis	X
Test Mode	UNII-2A_TX A Mode 5300 MHz

Horizontal

130 dBuV/m

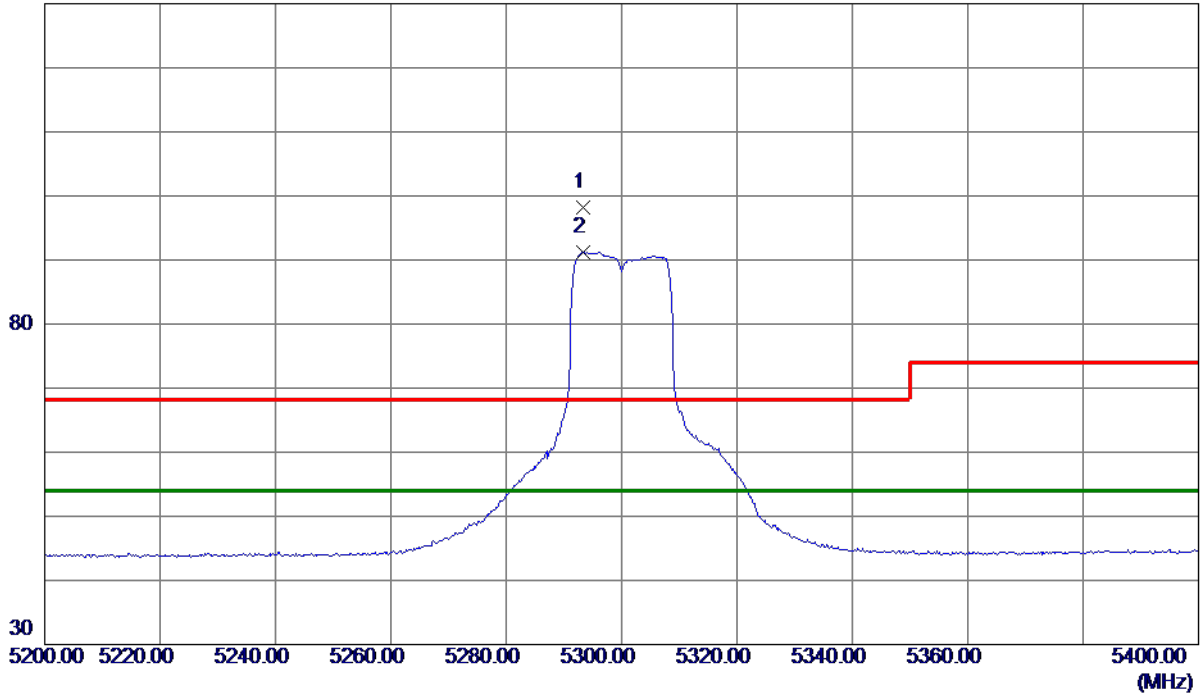

No.	Freq. MHz	Reading Level dBuV/m	Correct Factor dB	Measure ment dBuV/m	Limit dBuV/m	Margin dB	Detector	Comment
1	5293.4000	82.68	15.59	98.27	68.30	29.97	Peak	No Limit
2 *	5293.4000	75.61	15.59	91.20	54.00	37.20	AVG	No Limit

REMARKS:

- (1) Measurement Value = Reading Level + Correct Factor.
- (2) Margin Level = Measurement Value - Limit Value.

Orthogonal Axis	X
Test Mode	UNII-2A_TX A Mode 5300 MHz

Horizontal

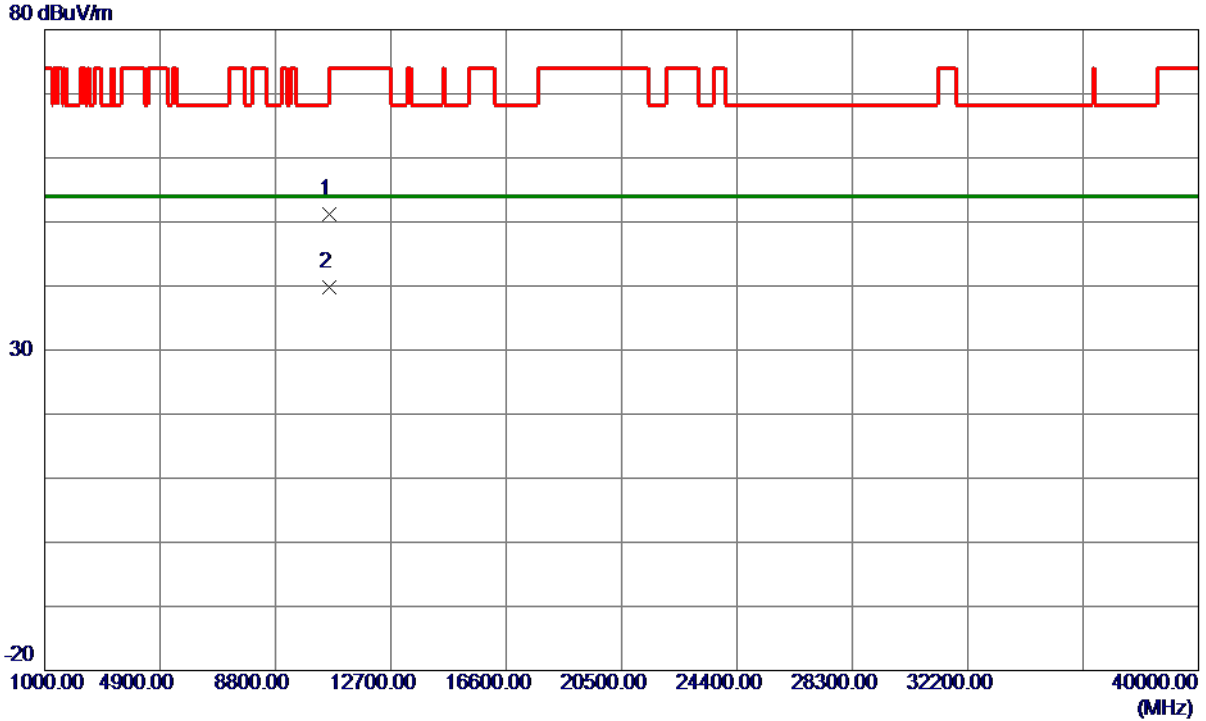

No.	Freq. MHz	Reading Level dBuV/m	Correct Factor dB	Measure ment dBuV/m	Limit dBuV/m	Margin dB	Detector	Comment
1	10609.0400	38.81	12.46	51.27	74.00	-22.73	Peak	
2 *	10609.1400	27.36	12.46	39.82	54.00	-14.18	AVG	

REMARKS:

- (1) Measurement Value = Reading Level + Correct Factor.
- (2) Margin Level = Measurement Value - Limit Value.

Orthogonal Axis	X
Test Mode	UNII-2A_TX A Mode 5320 MHz

Vertical

130 dBuV/m

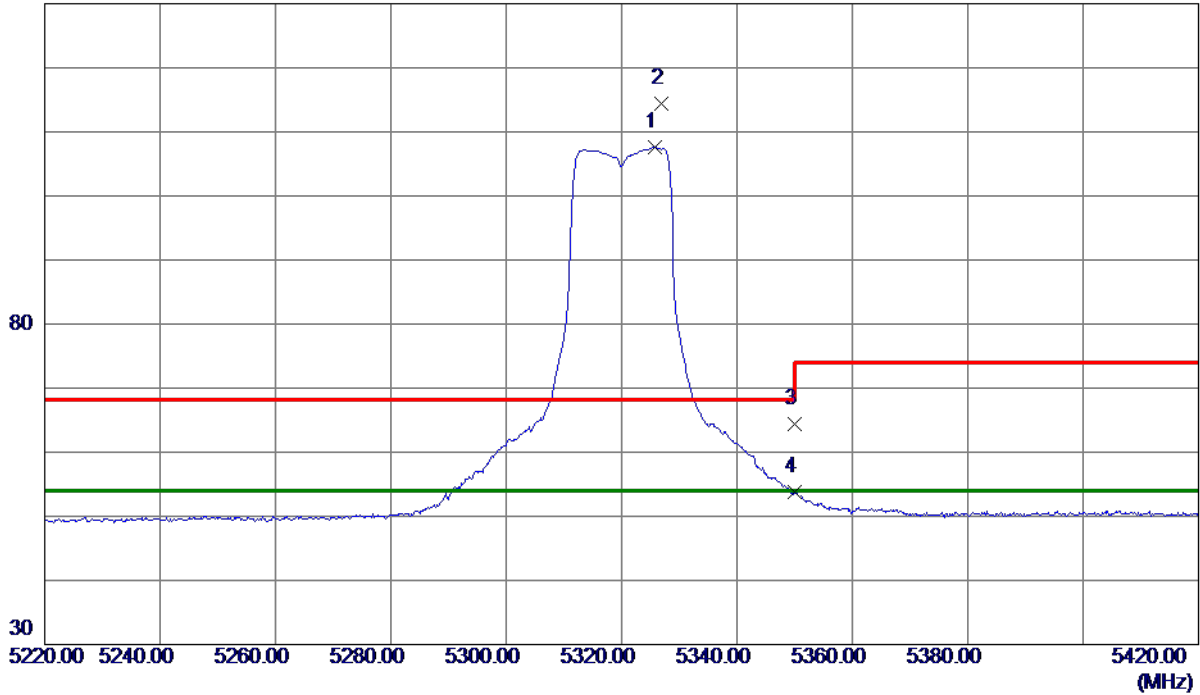

No.	Freq. MHz	Reading Level dBuV/m	Correct Factor dB	Measure ment dBuV/m	Limit dBuV/m	Margin dB	Detector	Comment
1 *	5325.8000	92.00	15.67	107.67	54.00	53.67	AVG	No Limit
2	5326.8000	98.65	15.67	114.32	68.30	46.02	Peak	No Limit
3	5350.0000	48.74	15.72	64.46	74.00	-9.54	Peak	
4	5350.0000	38.00	15.72	53.72	54.00	-0.28	AVG	

REMARKS:

- (1) Measurement Value = Reading Level + Correct Factor.
- (2) Margin Level = Measurement Value - Limit Value.

Orthogonal Axis	X
Test Mode	UNII-2A_TX A Mode 5320 MHz

Vertical

80 dBuV/m

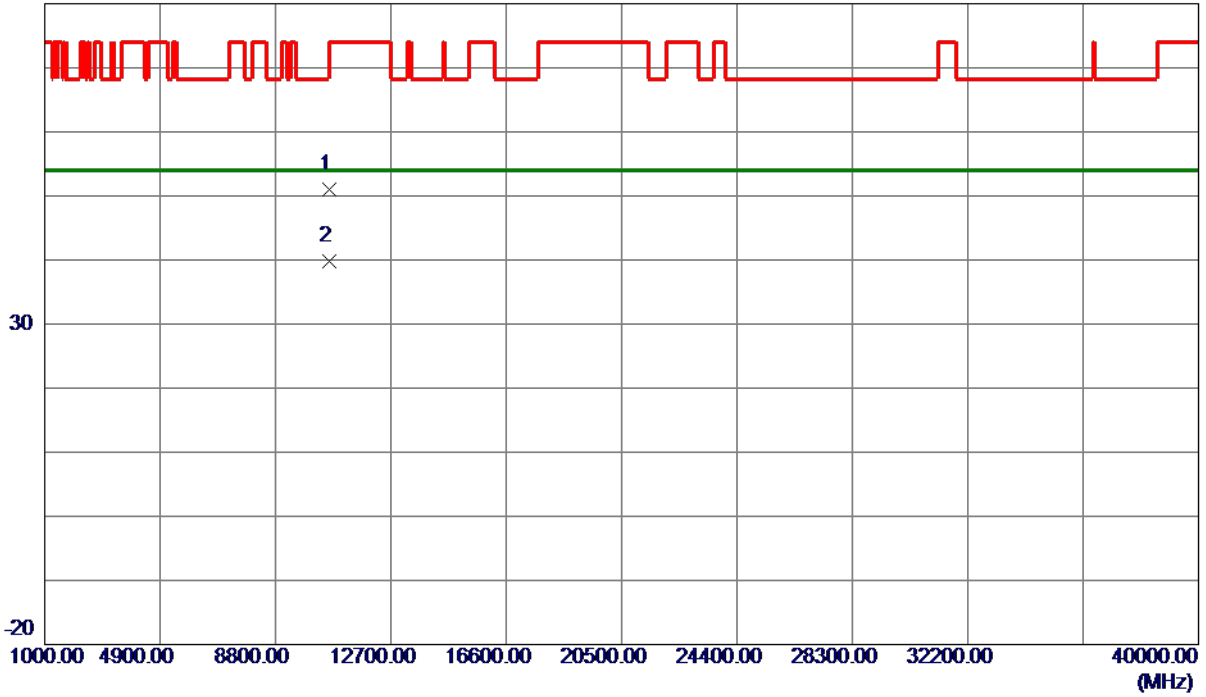

No.	Freq. MHz	Reading Level dBuV/m	Correct Factor dB	Measure ment dBuV/m	Limit dBuV/m	Margin dB	Detector	Comment
1	10631.4800	38.61	12.48	51.09	74.00	-22.91	Peak	
2 *	10637.2800	27.24	12.49	39.73	54.00	-14.27	AVG	

REMARKS:

- (1) Measurement Value = Reading Level + Correct Factor.
- (2) Margin Level = Measurement Value - Limit Value.

Orthogonal Axis	X
Test Mode	UNII-2A_TX A Mode 5320 MHz

Horizontal

130 dBuV/m

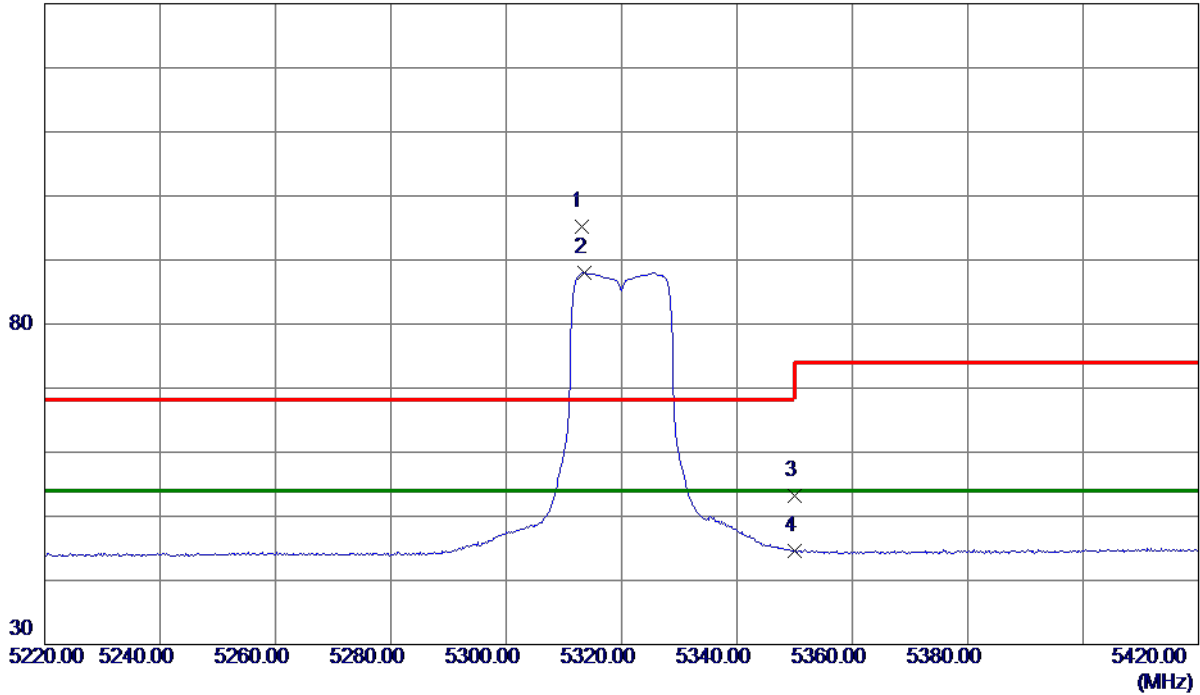

No.	Freq. MHz	Reading Level dBuV/m	Correct Factor dB	Measure ment dBuV/m	Limit dBuV/m	Margin dB	Detector	Comment
1	5313.0000	79.56	15.64	95.20	68.30	26.90	Peak	No Limit
2 *	5313.6000	72.37	15.64	88.01	54.00	34.01	AVG	No Limit
3	5350.0000	37.41	15.72	53.13	74.00	-20.87	Peak	
4	5350.0000	28.90	15.72	44.62	54.00	-9.38	AVG	

REMARKS:

- (1) Measurement Value = Reading Level + Correct Factor.
- (2) Margin Level = Measurement Value - Limit Value.

Orthogonal Axis	X
Test Mode	UNII-2A_TX A Mode 5320 MHz

Horizontal

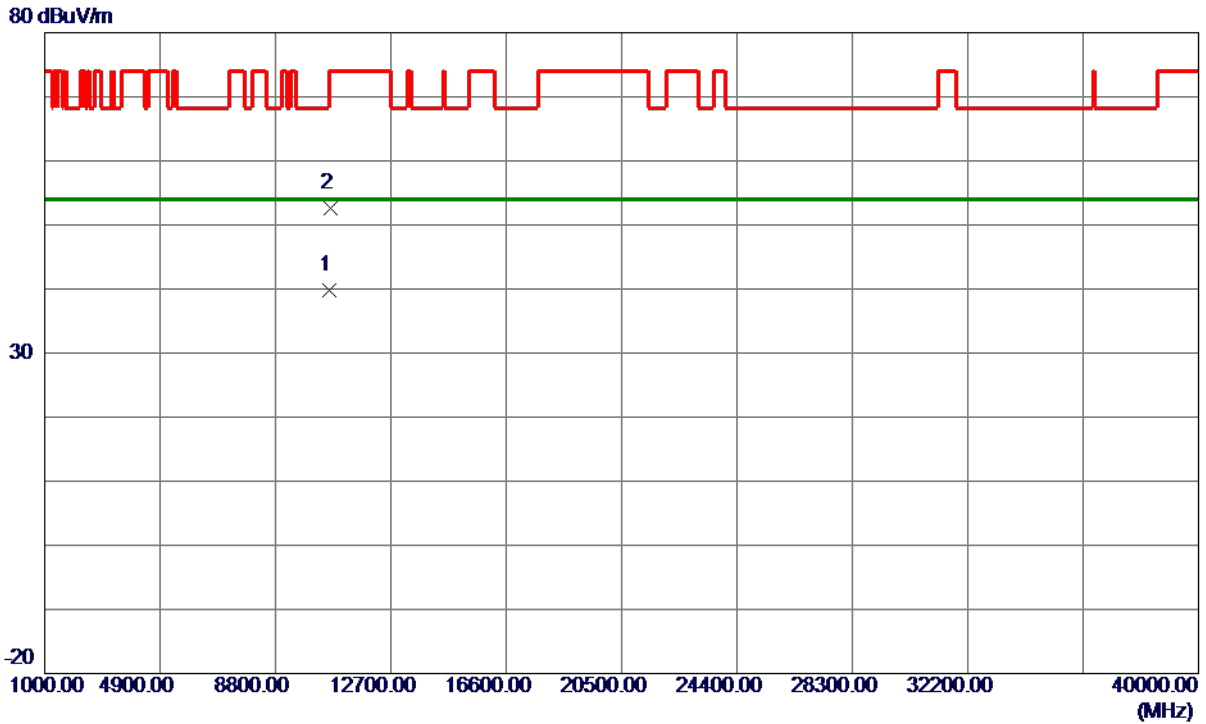

No.	Freq. MHz	Reading Level dBuV/m	Correct Factor dB	Measure ment dBuV/m	Limit dBuV/m	Margin dB	Detector	Comment
1 *	10640.6600	27.33	12.49	39.82	54.00	-14.18	AVG	
2	10647.5400	40.14	12.49	52.63	74.00	-21.37	Peak	

REMARKS:

- (1) Measurement Value = Reading Level + Correct Factor.
- (2) Margin Level = Measurement Value - Limit Value.

Orthogonal Axis	X
Test Mode	UNII-2C_TX A Mode 5500 MHz

Vertical

130 dBuV/m

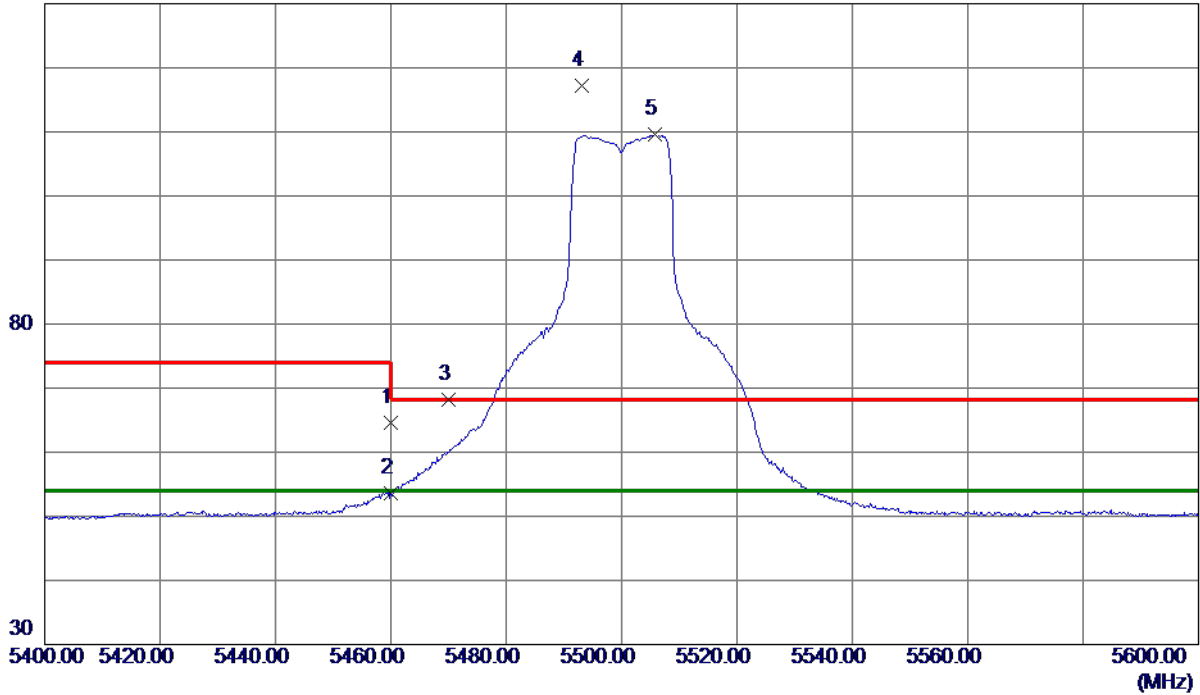

No.	Freq. MHz	Reading Level dBuV/m	Correct Factor dB	Measure ment dBuV/m	Limit dBuV/m	Margin dB	Detector	Comment
1	5460.0000	48.60	15.97	64.57	74.00	-9.43	Peak	
2	5460.0000	37.68	15.97	53.65	54.00	-0.35	AVG	
3	5470.0000	52.20	16.00	68.20	68.30	-0.10	Peak	
4	5493.2000	101.14	16.05	117.19	68.30	48.89	Peak	No Limit
5 *	5505.7000	93.44	16.08	109.52	54.00	55.52	AVG	No Limit

REMARKS:

- (1) Measurement Value = Reading Level + Correct Factor.
- (2) Margin Level = Measurement Value - Limit Value.

Orthogonal Axis	X
Test Mode	UNII-2C_TX A Mode 5500 MHz

Vertical

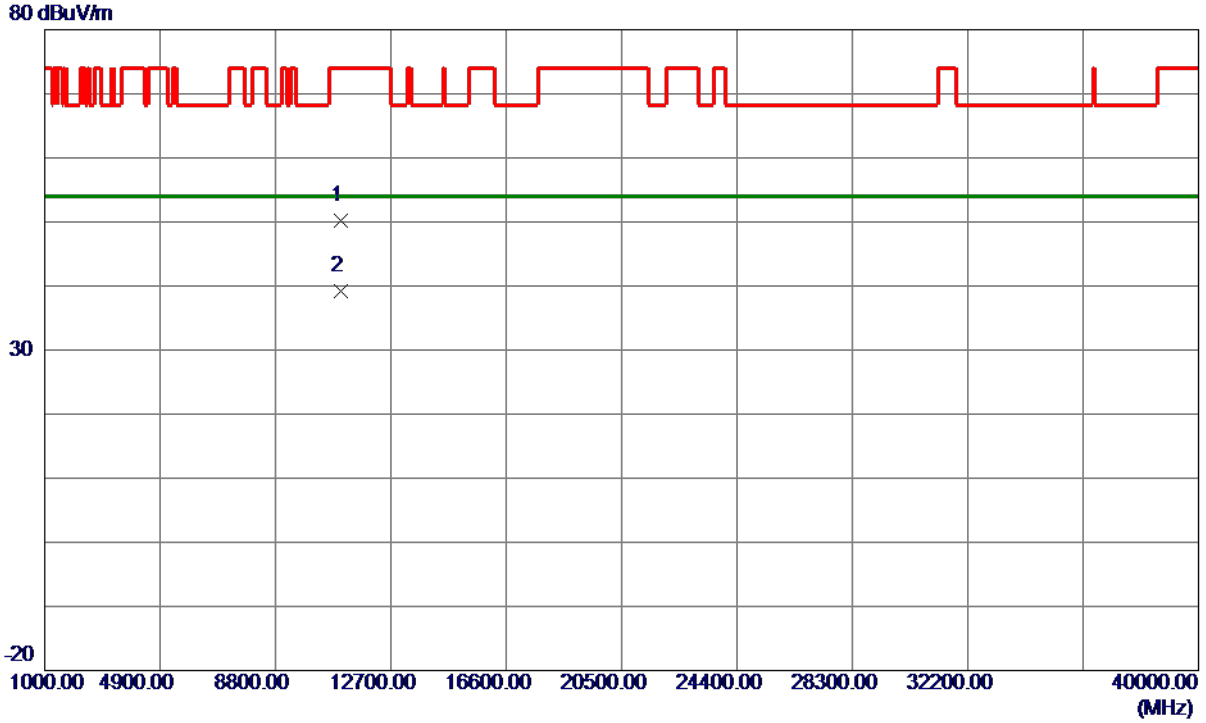

No.	Freq. MHz	Reading Level dBuV/m	Correct Factor dB	Measure ment dBuV/m	Limit dBuV/m	Margin dB	Detector	Comment
1	10996.9600	37.45	12.78	50.23	74.00	-23.77	Peak	
2 *	11007.2400	26.43	12.79	39.22	54.00	-14.78	AVG	

REMARKS:

- (1) Measurement Value = Reading Level + Correct Factor.
- (2) Margin Level = Measurement Value - Limit Value.

Orthogonal Axis	X
Test Mode	UNII-2C_TX A Mode 5500 MHz

Horizontal

130 dBuV/m

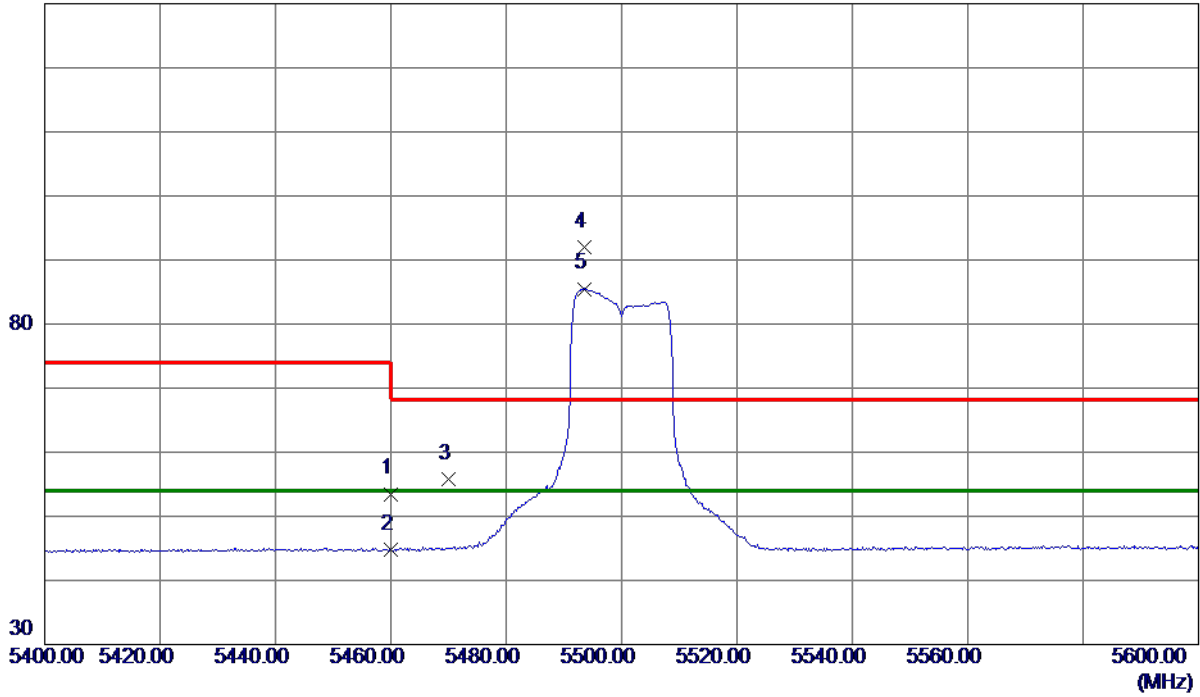

No.	Freq. MHz	Reading Level dBuV/m	Correct Factor dB	Measure ment dBuV/m	Limit dBuV/m	Margin dB	Detector	Comment
1	5460.0000	37.53	15.97	53.50	74.00	-20.50	Peak	
2	5460.0000	28.78	15.97	44.75	54.00	-9.25	AVG	
3	5470.0000	39.88	16.00	55.88	68.30	-12.42	Peak	
4	5493.6000	75.90	16.05	91.95	68.30	23.65	Peak	No Limit
5 *	5493.6000	69.45	16.05	85.50	54.00	31.50	AVG	No Limit

REMARKS:

- (1) Measurement Value = Reading Level + Correct Factor.
- (2) Margin Level = Measurement Value - Limit Value.

Orthogonal Axis	X
Test Mode	UNII-2C_TX A Mode 5500 MHz

Horizontal

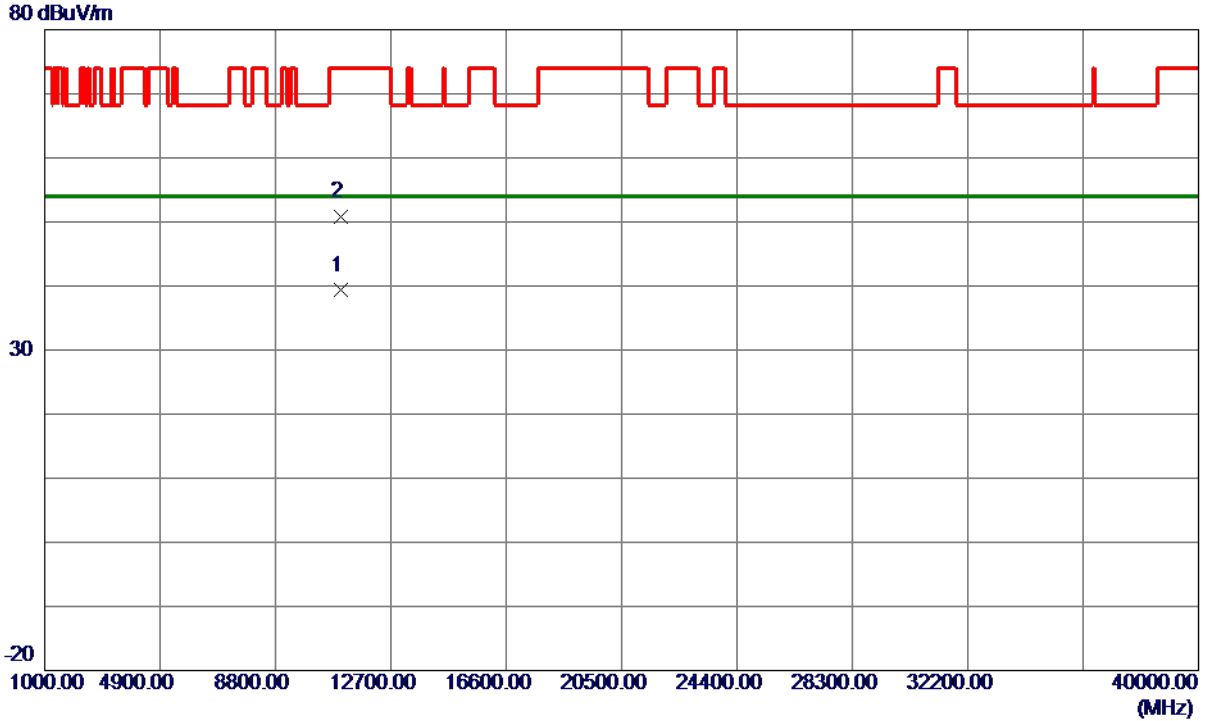

No.	Freq. MHz	Reading Level dBuV/m	Correct Factor dB	Measure ment dBuV/m	Limit dBuV/m	Margin dB	Detector	Comment
1 *	10992.9800	26.53	12.77	39.30	54.00	-14.70	AVG	
2	10993.2000	38.11	12.77	50.88	74.00	-23.12	Peak	

REMARKS:

- (1) Measurement Value = Reading Level + Correct Factor.
- (2) Margin Level = Measurement Value - Limit Value.

Orthogonal Axis	X
Test Mode	UNII-2C_TX A Mode 5580 MHz

Vertical

130 dBuV/m

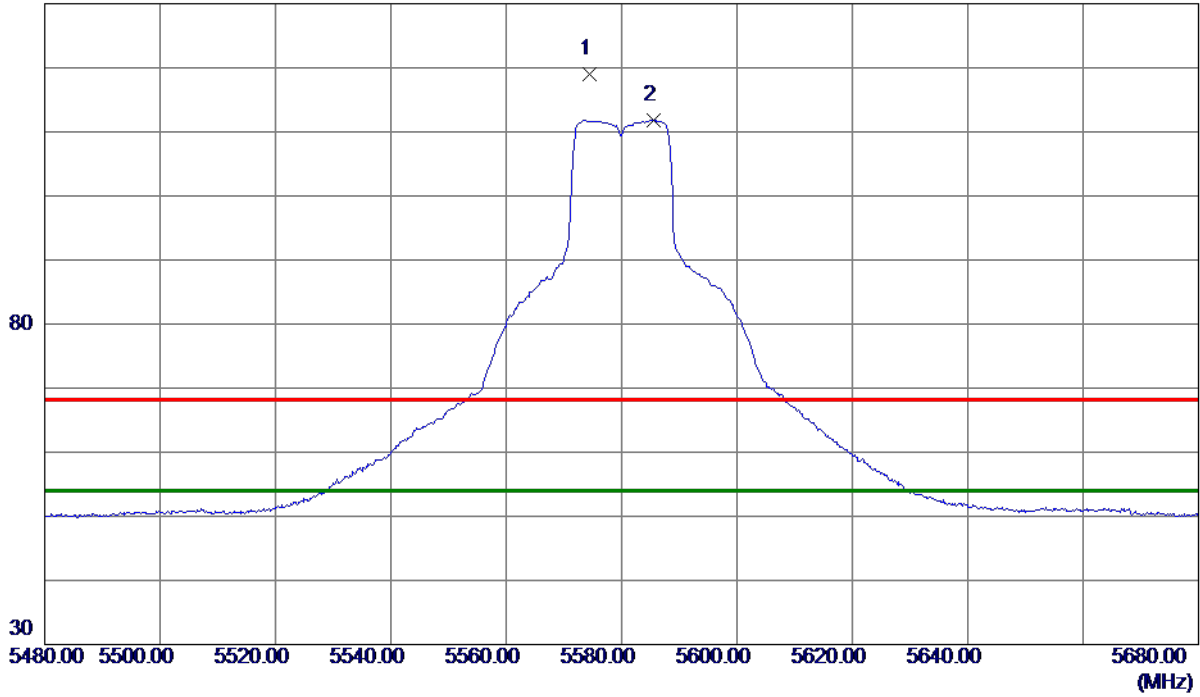

No.	Freq. MHz	Reading Level dBuV/m	Correct Factor dB	Measure ment dBuV/m	Limit dBuV/m	Margin dB	Detector	Comment
1	5574.4000	102.69	16.21	118.90	68.30	50.60	Peak	No Limit
2 *	5585.6000	95.65	16.24	111.89	54.00	57.89	AVG	No Limit

REMARKS:

- (1) Measurement Value = Reading Level + Correct Factor.
- (2) Margin Level = Measurement Value - Limit Value.

Orthogonal Axis	X
Test Mode	UNII-2C_TX A Mode 5580 MHz

Vertical

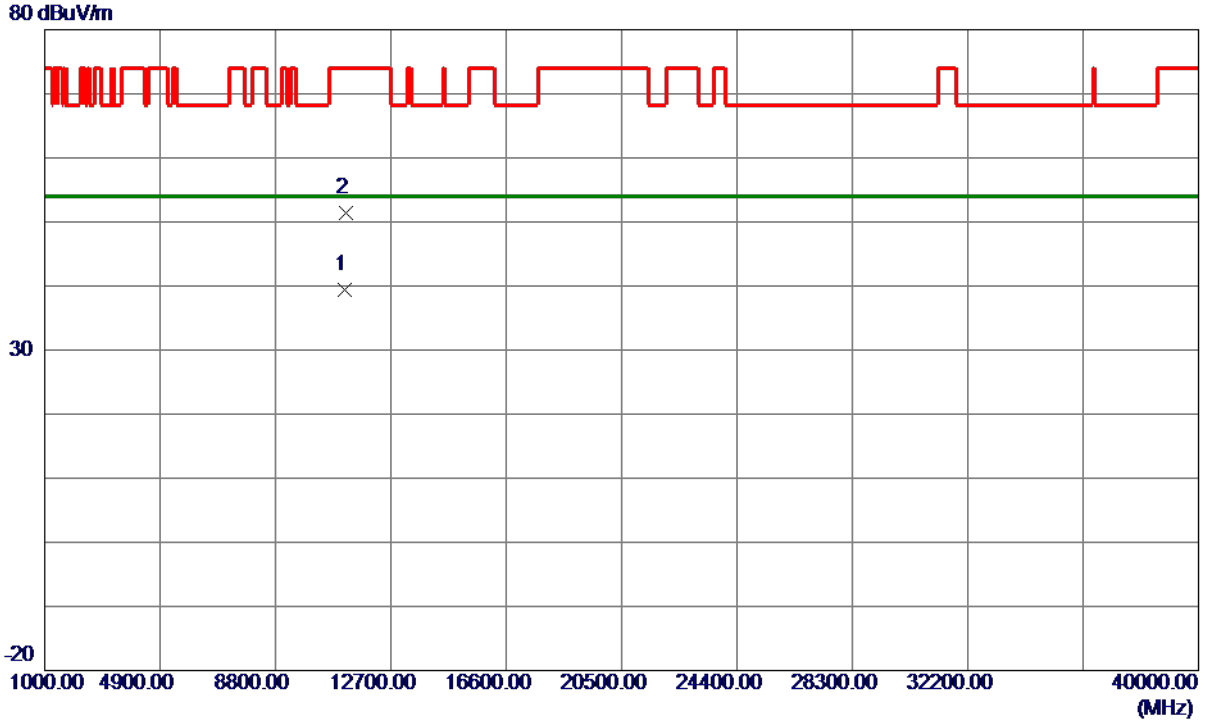

No.	Freq. MHz	Reading Level dBuV/m	Correct Factor dB	Measure ment dBuV/m	Limit dBuV/m	Margin dB	Detector	Comment
1 *	11150.6800	26.52	12.89	39.41	54.00	-14.59	AVG	
2	11163.8200	38.45	12.90	51.35	74.00	-22.65	Peak	

REMARKS:

- (1) Measurement Value = Reading Level + Correct Factor.
- (2) Margin Level = Measurement Value - Limit Value.

Orthogonal Axis	X
Test Mode	UNII-2C_TX A Mode 5580 MHz

Horizontal

130 dBuV/m

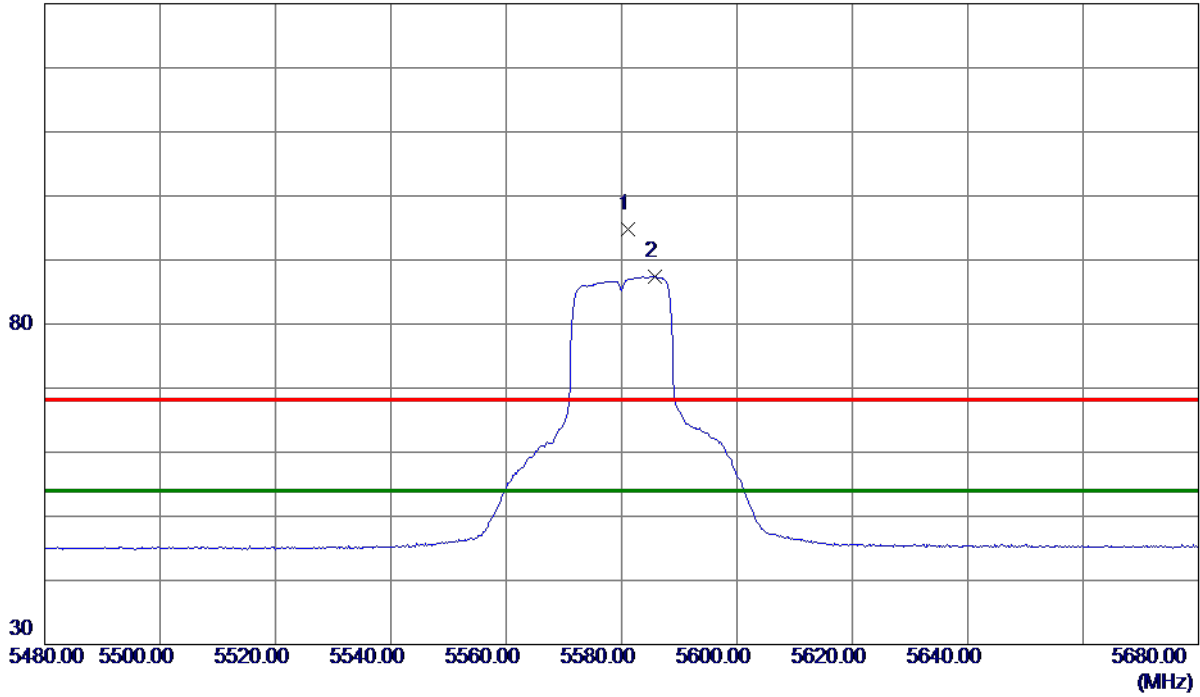

No.	Freq. MHz	Reading Level dBuV/m	Correct Factor dB	Measure ment dBuV/m	Limit dBuV/m	Margin dB	Detector	Comment
1	5581.2000	78.56	16.23	94.79	68.30	26.49	Peak	No Limit
2 *	5585.8000	71.24	16.24	87.48	54.00	33.48	AVG	No Limit

REMARKS:

- (1) Measurement Value = Reading Level + Correct Factor.
- (2) Margin Level = Measurement Value - Limit Value.

Orthogonal Axis	X
Test Mode	UNII-2C_TX A Mode 5580 MHz

Horizontal

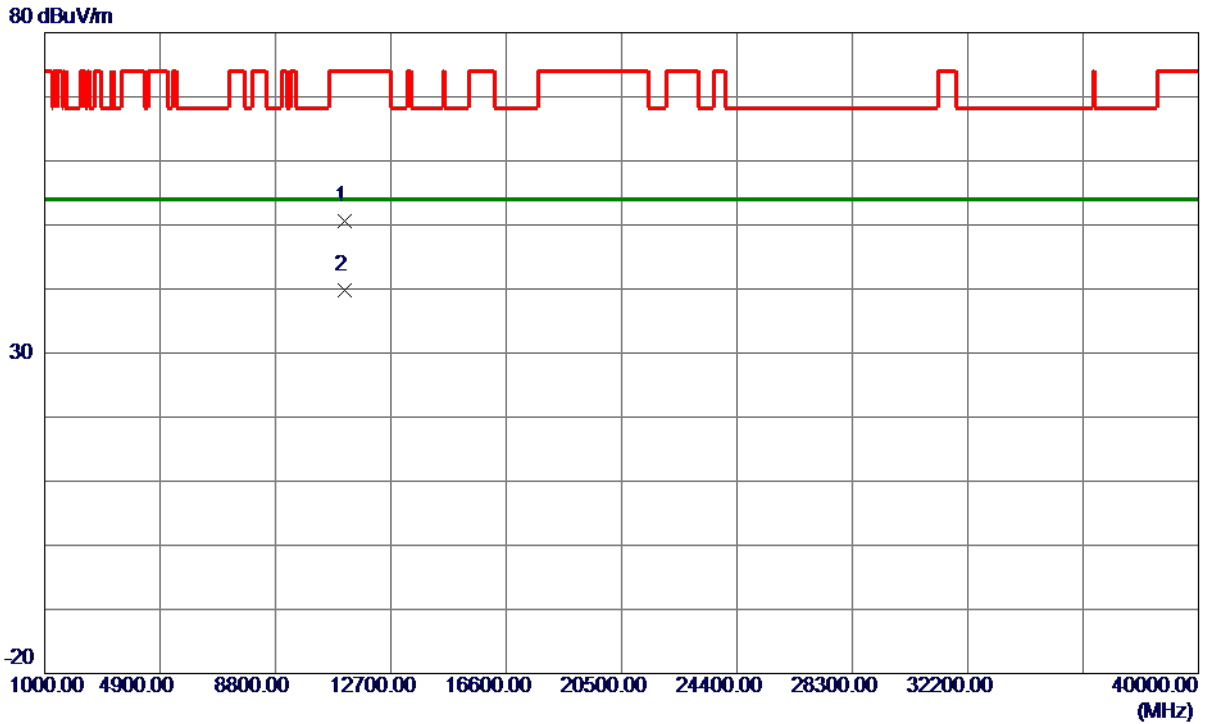

No.	Freq. MHz	Reading Level dBuV/m	Correct Factor dB	Measure ment dBuV/m	Limit dBuV/m	Margin dB	Detector	Comment
1	11150.0000	37.80	12.89	50.69	74.00	-23.31	Peak	
2 *	11161.3000	26.97	12.90	39.87	54.00	-14.13	AVG	

REMARKS:

- (1) Measurement Value = Reading Level + Correct Factor.
- (2) Margin Level = Measurement Value - Limit Value.

Orthogonal Axis	X
Test Mode	UNII-2C_TX A Mode 5700 MHz

Vertical

130 dBuV/m

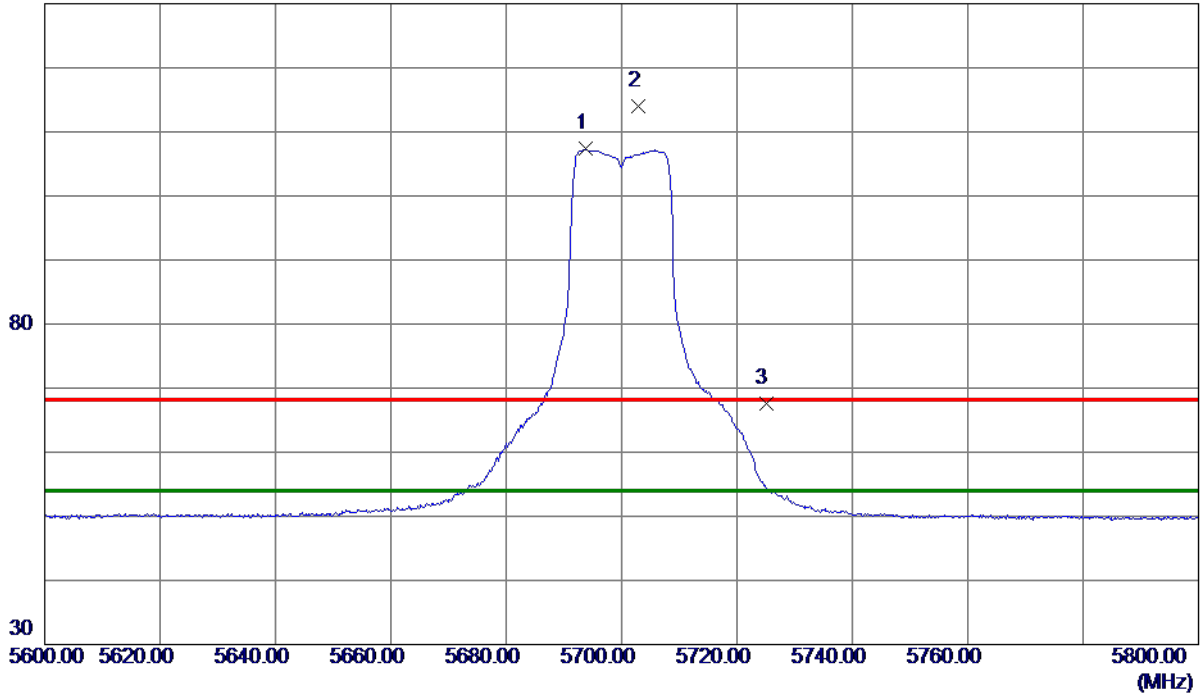

No.	Freq. MHz	Reading Level dBuV/m	Correct Factor dB	Measure ment dBuV/m	Limit dBuV/m	Margin dB	Detector	Comment
1 *	5693.7000	90.86	16.45	107.31	54.00	53.31	AVG	No Limit
2	5702.8000	97.57	16.47	114.04	68.30	45.74	Peak	No Limit
3	5725.0000	51.01	16.51	67.52	68.30	-0.78	Peak	

REMARKS:

- (1) Measurement Value = Reading Level + Correct Factor.
- (2) Margin Level = Measurement Value - Limit Value.

Orthogonal Axis	X
Test Mode	UNII-2C_TX A Mode 5700 MHz

Vertical

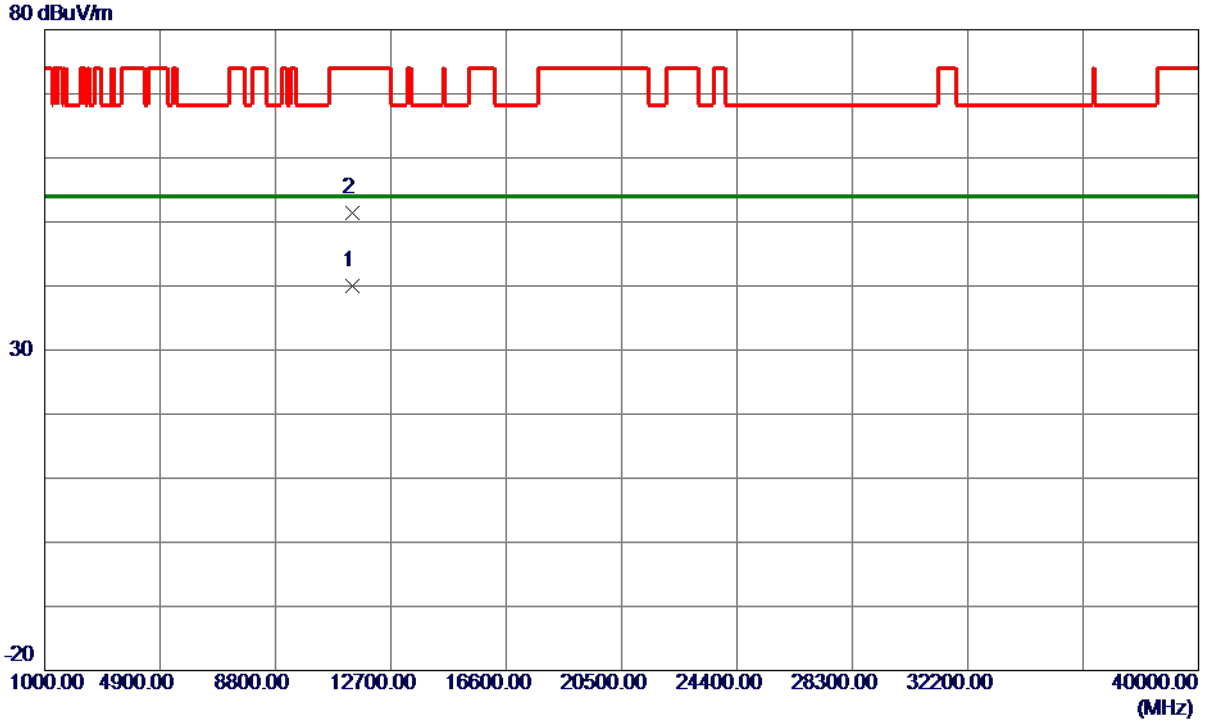

No.	Freq. MHz	Reading Level dBuV/m	Correct Factor dB	Measure ment dBuV/m	Limit dBuV/m	Margin dB	Detector	Comment
1 *	11395.5800	26.91	13.08	39.99	54.00	-14.01	AVG	
2	11401.8200	38.29	13.08	51.37	74.00	-22.63	Peak	

REMARKS:

- (1) Measurement Value = Reading Level + Correct Factor.
- (2) Margin Level = Measurement Value - Limit Value.

Orthogonal Axis	X
Test Mode	UNII-2C_TX A Mode 5700 MHz

Horizontal

130 dBuV/m

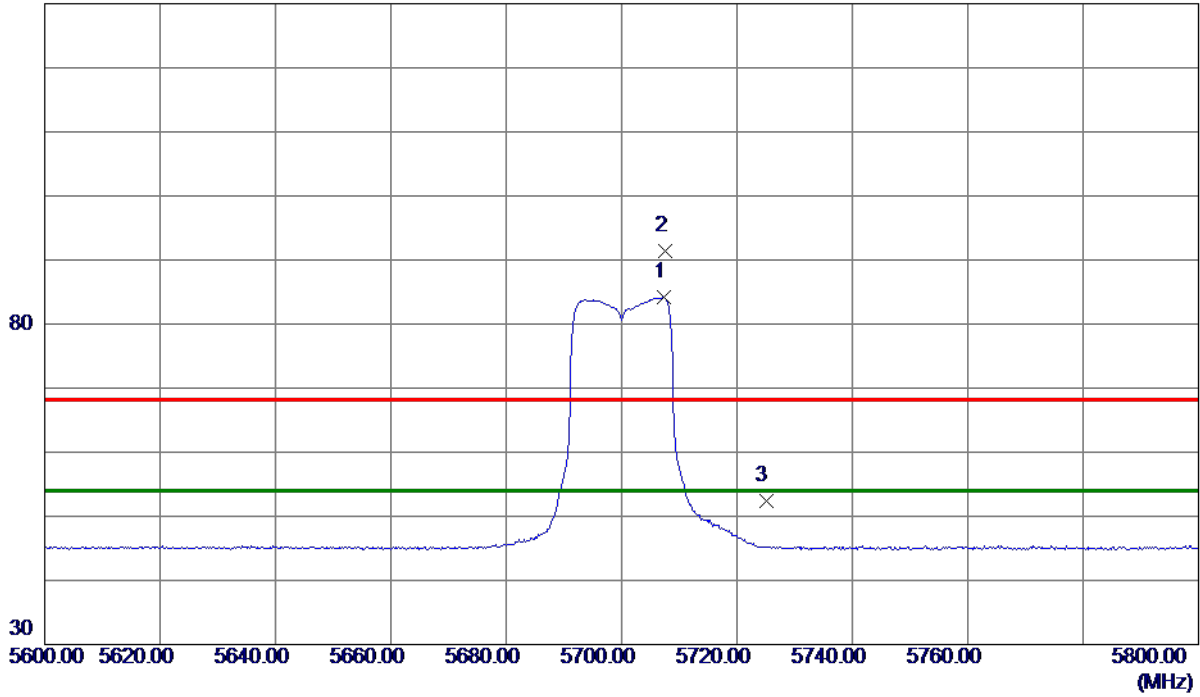

No.	Freq. MHz	Reading Level dBuV/m	Correct Factor dB	Measure ment dBuV/m	Limit dBuV/m	Margin dB	Detector	Comment
1 *	5707.4000	67.69	16.48	84.17	54.00	30.17	AVG	No Limit
2	5707.6000	74.89	16.48	91.37	68.30	23.07	Peak	No Limit
3	5725.0000	35.87	16.51	52.38	68.30	-15.92	Peak	

REMARKS:

- (1) Measurement Value = Reading Level + Correct Factor.
- (2) Margin Level = Measurement Value - Limit Value.

Orthogonal Axis	X
Test Mode	UNII-2C_TX A Mode 5700 MHz

Horizontal

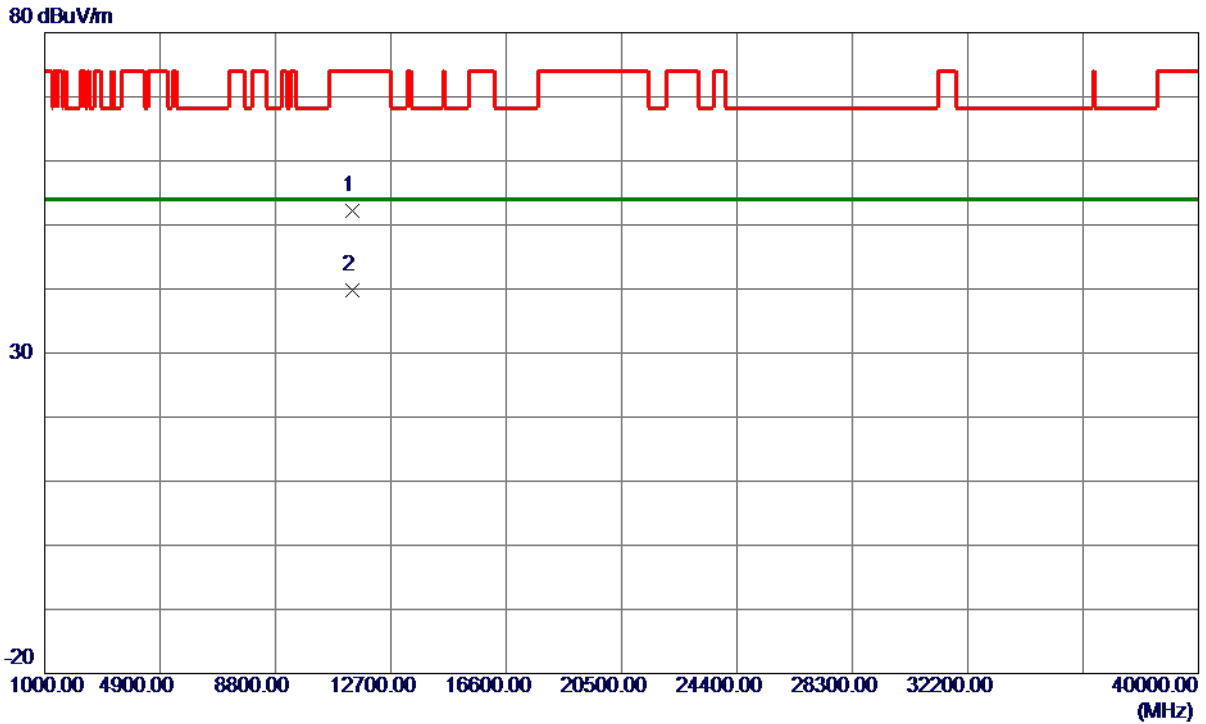

No.	Freq. MHz	Reading Level dBuV/m	Correct Factor dB	Measure ment dBuV/m	Limit dBuV/m	Margin dB	Detector	Comment
1	11402.7600	39.17	13.08	52.25	74.00	-21.75	Peak	
2 *	11403.0400	26.80	13.08	39.88	54.00	-14.12	AVG	

REMARKS:

- (1) Measurement Value = Reading Level + Correct Factor.
- (2) Margin Level = Measurement Value - Limit Value.

Orthogonal Axis	X
Test Mode	UNII-3_TX A Mode 5745 MHz

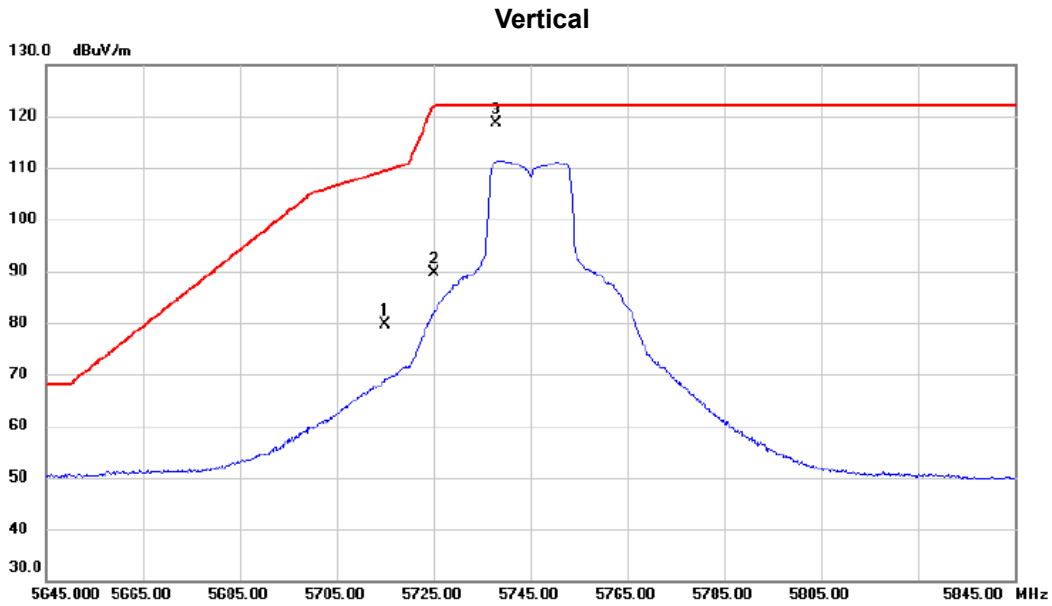

No. Mk.	Freq. MHz	Reading Level dBuV	Correct Factor dB	Measurement dBuV/m	Limit dBuV/m	Margin dB	Detector	Comment
1	5715.000	63.14	16.49	79.63	109.40	-29.77	peak	
2	5725.000	73.03	16.51	89.54	122.20	-32.66	peak	
3 *	5737.900	102.11	16.54	118.65	122.20	-3.55	peak	No Limit

REMARKS:

- (1) Measurement Value = Reading Level + Correct Factor.
- (2) Margin Level = Measurement Value - Limit Value.

Orthogonal Axis	X
Test Mode	UNII-3_TX A Mode 5745 MHz

Vertical

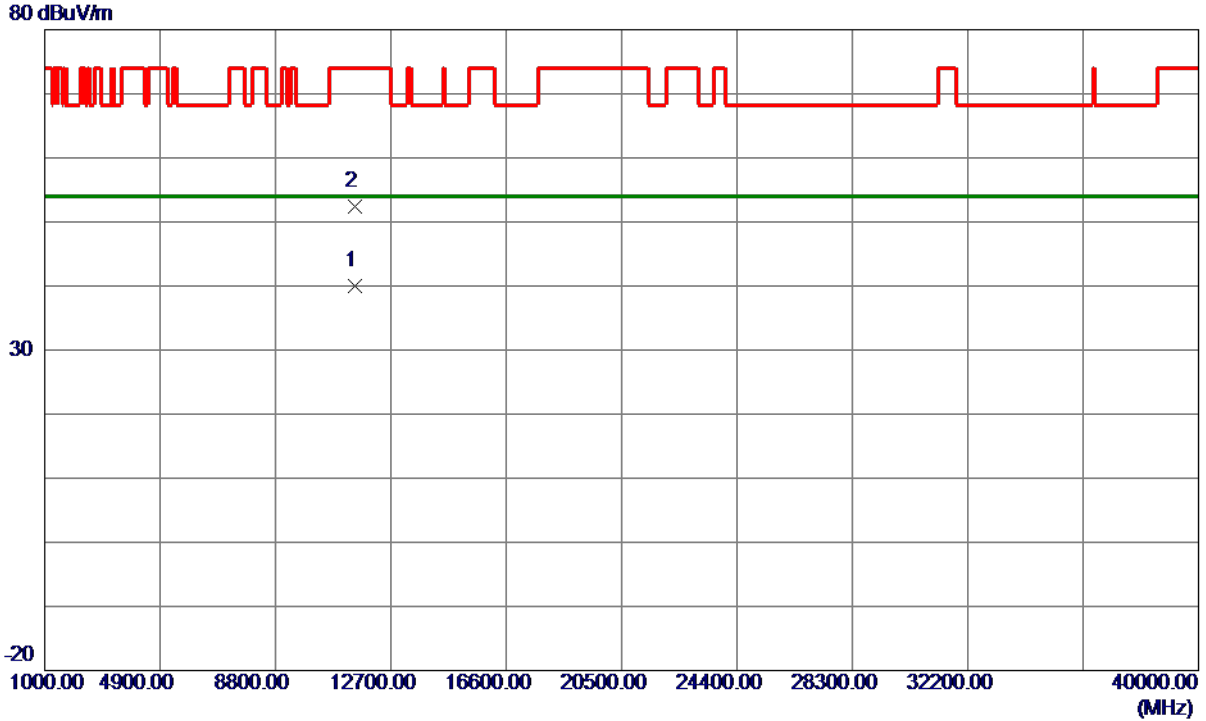

No.	Freq. MHz	Reading Level dBuV/m	Correct Factor dB	Measure ment dBuV/m	Limit dBuV/m	Margin dB	Detector	Comment
1 *	11481.3600	26.91	13.14	40.05	54.00	-13.95	AVG	
2	11491.5599	39.27	13.15	52.42	74.00	-21.58	Peak	

REMARKS:

- (1) Measurement Value = Reading Level + Correct Factor.
- (2) Margin Level = Measurement Value - Limit Value.

Orthogonal Axis	X
Test Mode	UNII-3_TX A Mode 5745 MHz

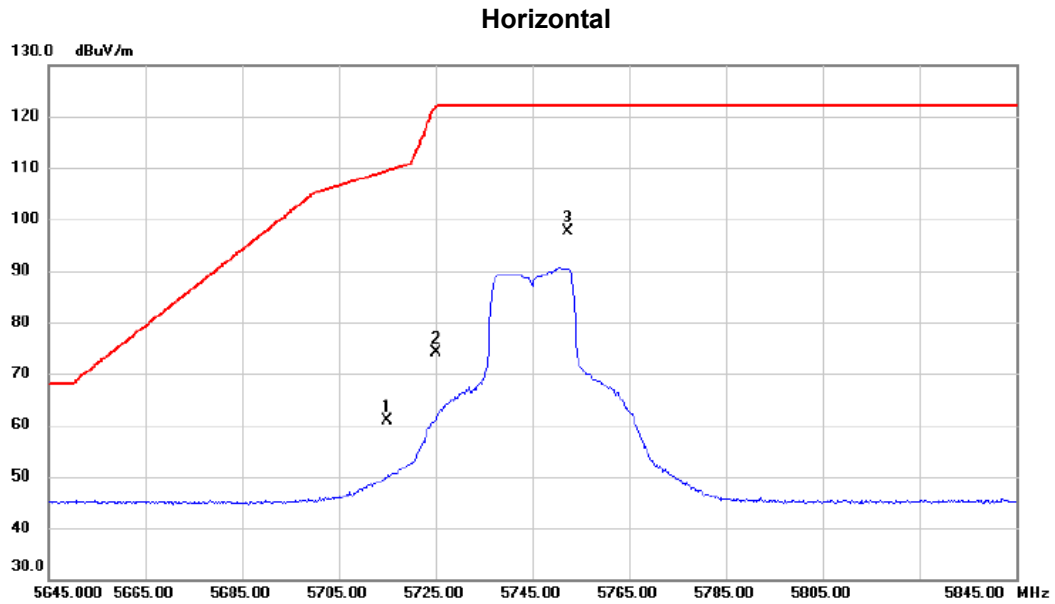

No.	Mk.	Freq. MHz	Reading Level dBuV	Correct Factor dB	Measure- ment dBuV/m	Limit dBuV/m	Margin dB	Detector	Comment
1		5715.000	44.40	16.49	60.89	109.40	-48.51	peak	
2		5725.000	57.72	16.51	74.23	122.20	-47.97	peak	
3	*	5752.400	81.18	16.57	97.75	122.20	-24.45	peak	No Limit

REMARKS:

- (1) Measurement Value = Reading Level + Correct Factor.
- (2) Margin Level = Measurement Value - Limit Value.

Orthogonal Axis	X
Test Mode	UNII-3_TX A Mode 5745 MHz

Horizontal

80 dBuV/m

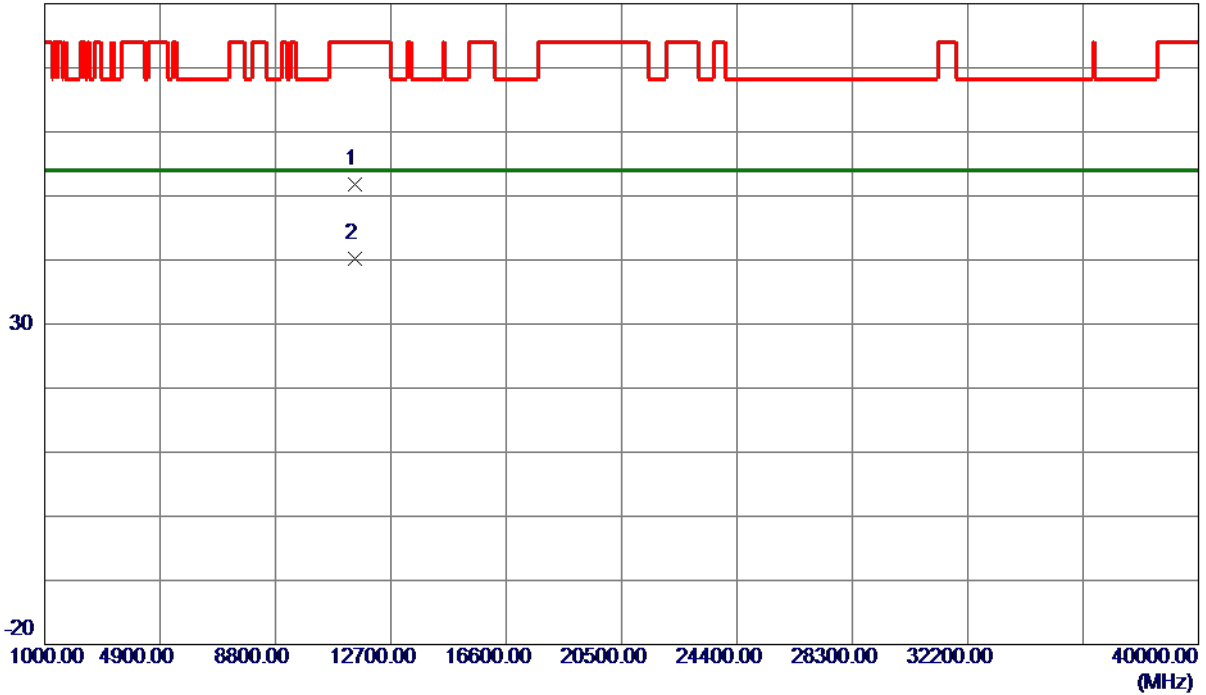

No.	Freq. MHz	Reading Level dBuV/m	Correct Factor dB	Measure ment dBuV/m	Limit dBuV/m	Margin dB	Detector	Comment
1	11484.4400	38.67	13.14	51.81	74.00	-22.19	Peak	
2 *	11488.3600	26.96	13.15	40.11	54.00	-13.89	AVG	

REMARKS:

- (1) Measurement Value = Reading Level + Correct Factor.
- (2) Margin Level = Measurement Value - Limit Value.

Orthogonal Axis	X
Test Mode	UNII-3_TX A Mode 5785 MHz

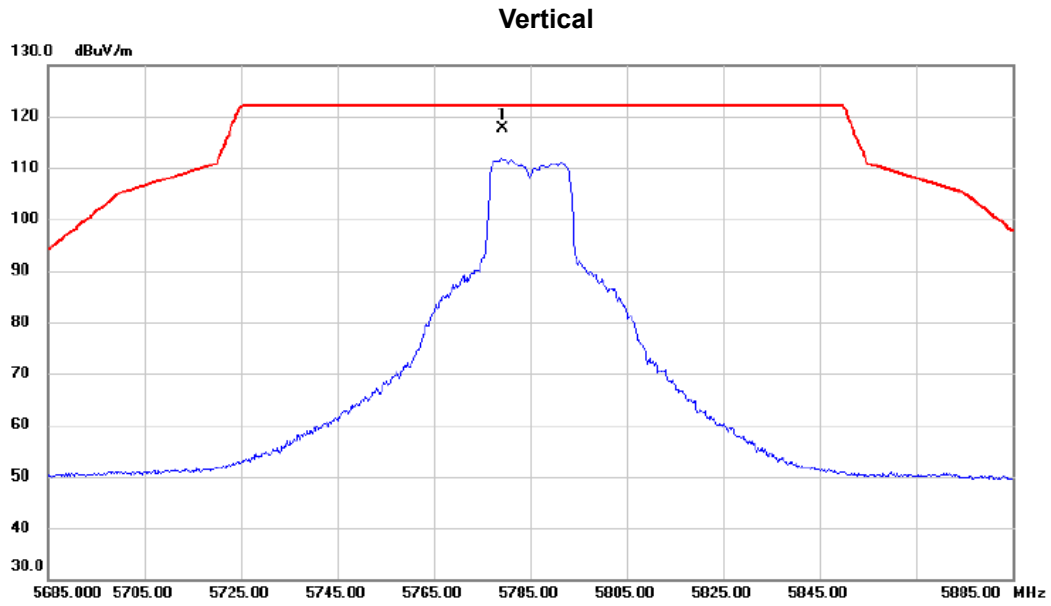

No.	Mk.	Freq.	Reading Level	Correct Factor	Measurement	Limit	Margin	Detector	Comment
		MHz	dBuV	dB	dBuV/m	dBuV/m	dB		
1	*	5779.400	101.11	16.62	117.73	122.20	-4.47	peak	No Limit

REMARKS:

- (1) Measurement Value = Reading Level + Correct Factor.
- (2) Margin Level = Measurement Value - Limit Value.

Orthogonal Axis	X
Test Mode	UNII-3_TX A Mode 5785 MHz

Vertical

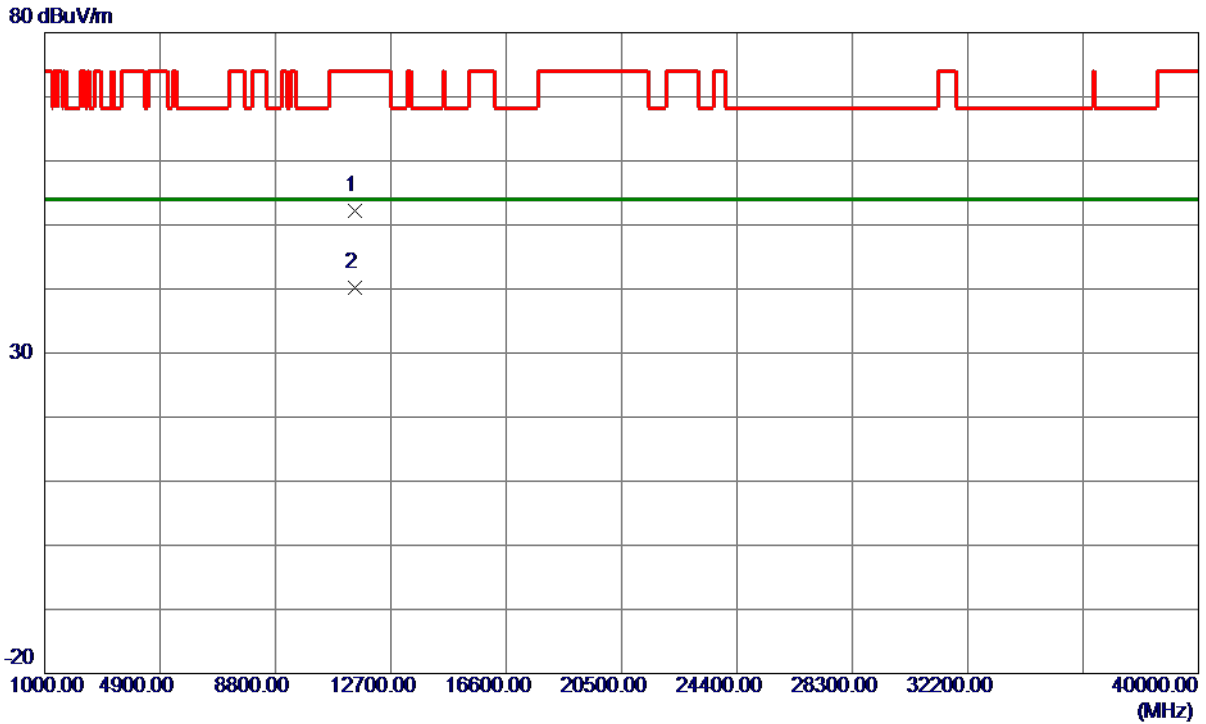

No.	Freq. MHz	Reading Level dBuV/m	Correct Factor dB	Measure ment dBuV/m	Limit dBuV/m	Margin dB	Detector	Comment
1	11492.5199	39.05	13.15	52.20	74.00	-21.80	Peak	
2 *	11494.9400	27.08	13.15	40.23	54.00	-13.77	AVG	

REMARKS:

- (1) Measurement Value = Reading Level + Correct Factor.
- (2) Margin Level = Measurement Value - Limit Value.

Orthogonal Axis	X
Test Mode	UNII-3_TX A Mode 5785 MHz

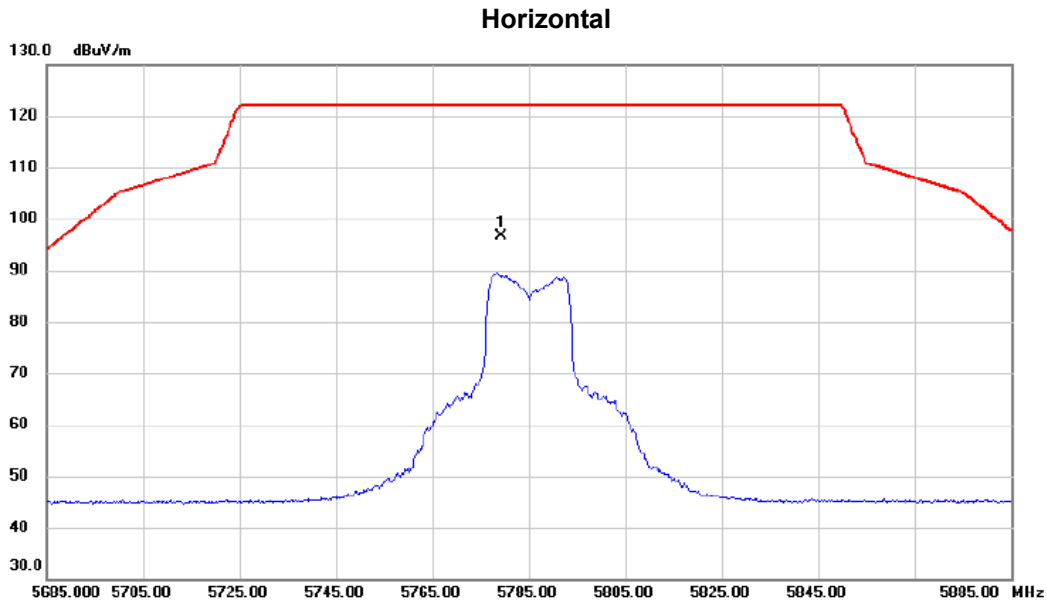

No.	Mk.	Freq.	Reading Level	Correct Factor	Measurement	Limit	Margin	Detector	Comment
		MHz	dBuV	dB	dBuV/m	dBuV/m	dB		
1	*	5779.400	80.06	16.62	96.68	122.20	-25.52	peak	No Limit

REMARKS:

- (1) Measurement Value = Reading Level + Correct Factor.
- (2) Margin Level = Measurement Value - Limit Value.

Orthogonal Axis	X
Test Mode	UNII-3_TX A Mode 5785 MHz

Horizontal

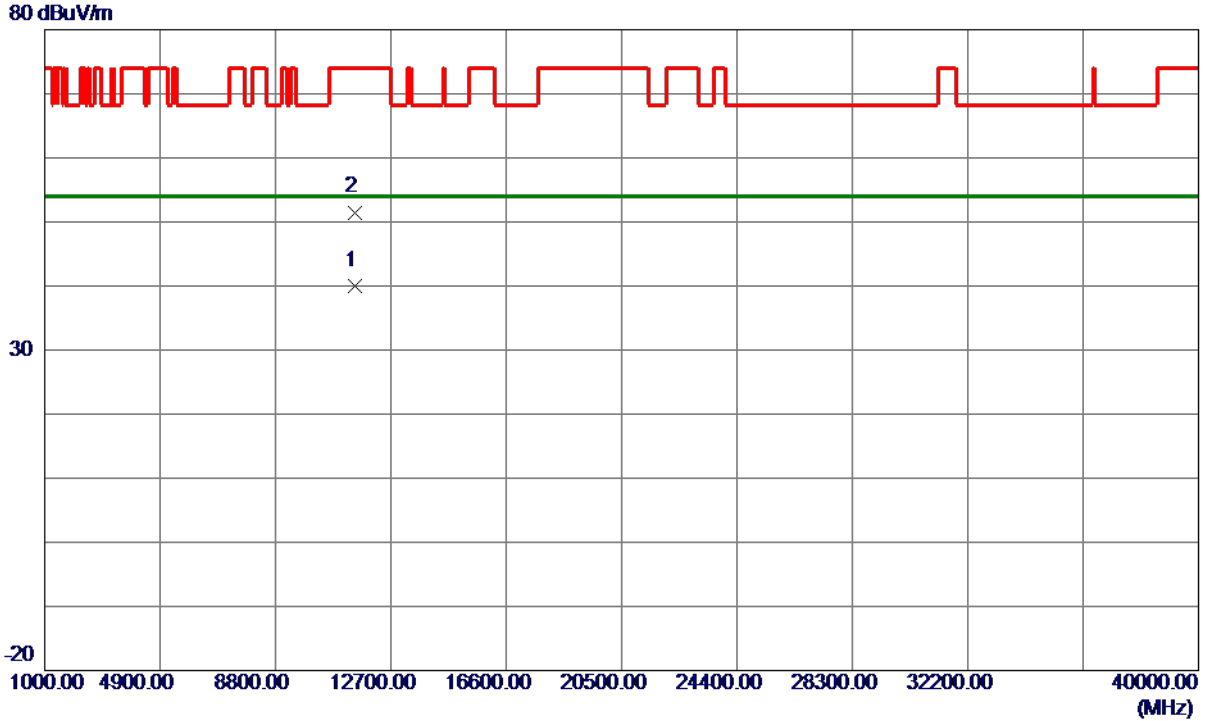

No.	Freq. MHz	Reading Level dBuV/m	Correct Factor dB	Measure ment dBuV/m	Limit dBuV/m	Margin dB	Detector	Comment
1 *	11489.2400	26.91	13.15	40.06	54.00	-13.94	AVG	
2	11499.9000	38.35	13.15	51.50	74.00	-22.50	Peak	

REMARKS:

- (1) Measurement Value = Reading Level + Correct Factor.
- (2) Margin Level = Measurement Value - Limit Value.

Orthogonal Axis	X
Test Mode	UNII-3_TX A Mode 5825 MHz

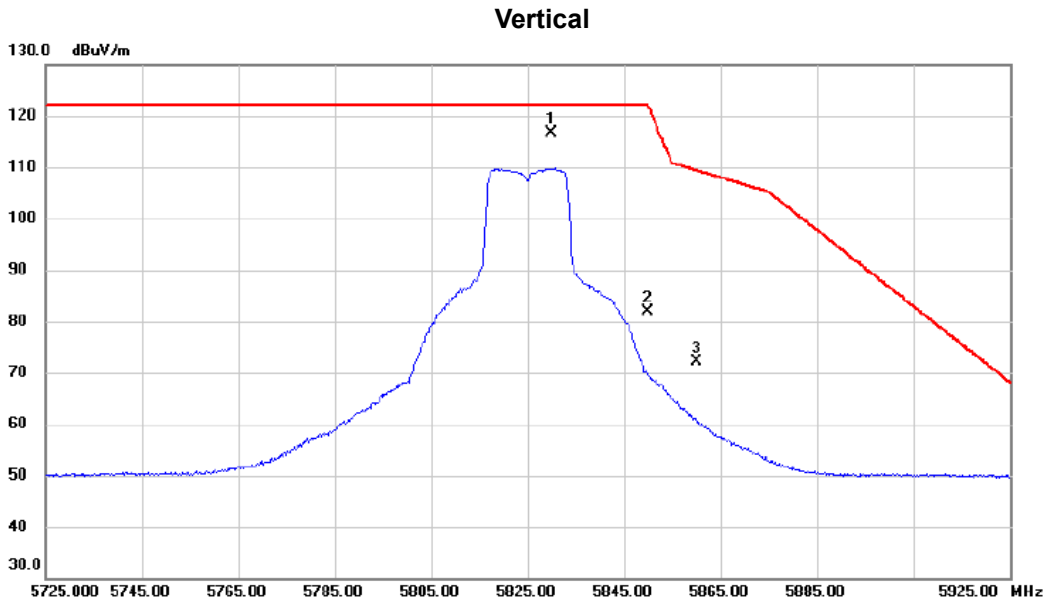

No. Mk.	Freq. MHz	Reading Level dBuV	Correct Factor dB	Measurement dBuV/m	Limit dBuV/m	Margin dB	Detector	Comment
1 *	5829.900	99.81	16.73	116.54	122.20	-5.66	peak	No Limit
2	5850.000	65.22	16.76	81.98	122.20	-40.22	peak	
3	5860.000	55.27	16.79	72.06	109.40	-37.34	peak	

REMARKS:

- (1) Measurement Value = Reading Level + Correct Factor.
- (2) Margin Level = Measurement Value - Limit Value.

Orthogonal Axis	X
Test Mode	UNII-3_TX A Mode 5825 MHz

Vertical

80 dBuV/m

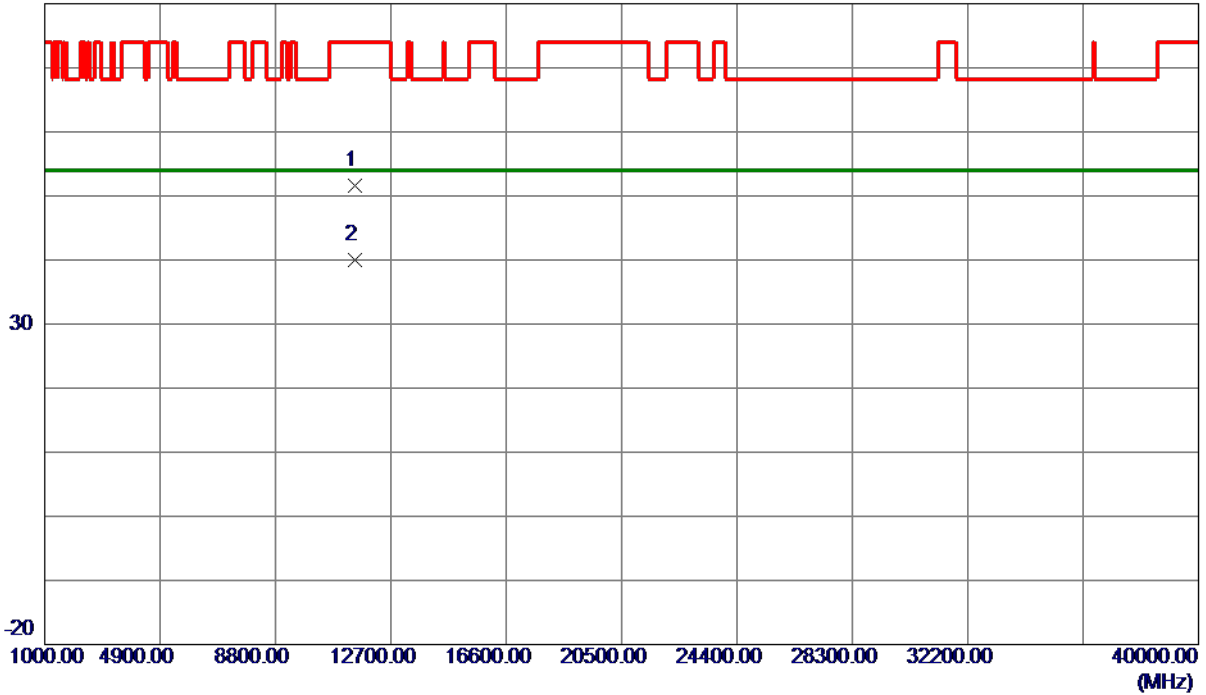

No.	Freq. MHz	Reading Level dBuV/m	Correct Factor dB	Measure ment dBuV/m	Limit dBuV/m	Margin dB	Detector	Comment
1	11495.3600	38.45	13.15	51.60	74.00	-22.40	Peak	
2 *	11495.4600	26.94	13.15	40.09	54.00	-13.91	AVG	

REMARKS:

- (1) Measurement Value = Reading Level + Correct Factor.
- (2) Margin Level = Measurement Value - Limit Value.

Orthogonal Axis	X
Test Mode	UNII-3_TX A Mode 5825 MHz

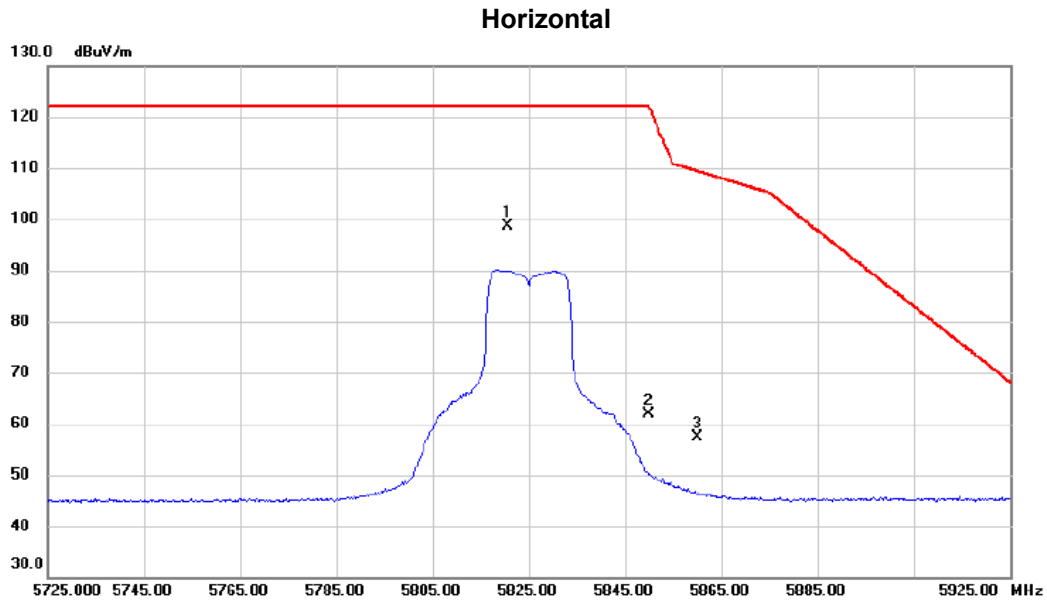

No.	Mk.	Freq. MHz	Reading Level dBuV	Correct Factor dB	Measure- ment dBuV/m	Limit dBuV/m	Margin dB	Detector	Comment
1	*	5820.600	81.99	16.70	98.69	122.20	-23.51	peak	No Limit
2		5850.000	45.20	16.76	61.96	122.20	-60.24	peak	
3		5860.000	40.47	16.79	57.26	109.40	-52.14	peak	

REMARKS:

- (1) Measurement Value = Reading Level + Correct Factor.
- (2) Margin Level = Measurement Value - Limit Value.

Orthogonal Axis	X
Test Mode	UNII-3_TX A Mode 5825 MHz

Horizontal

80 dBuV/m

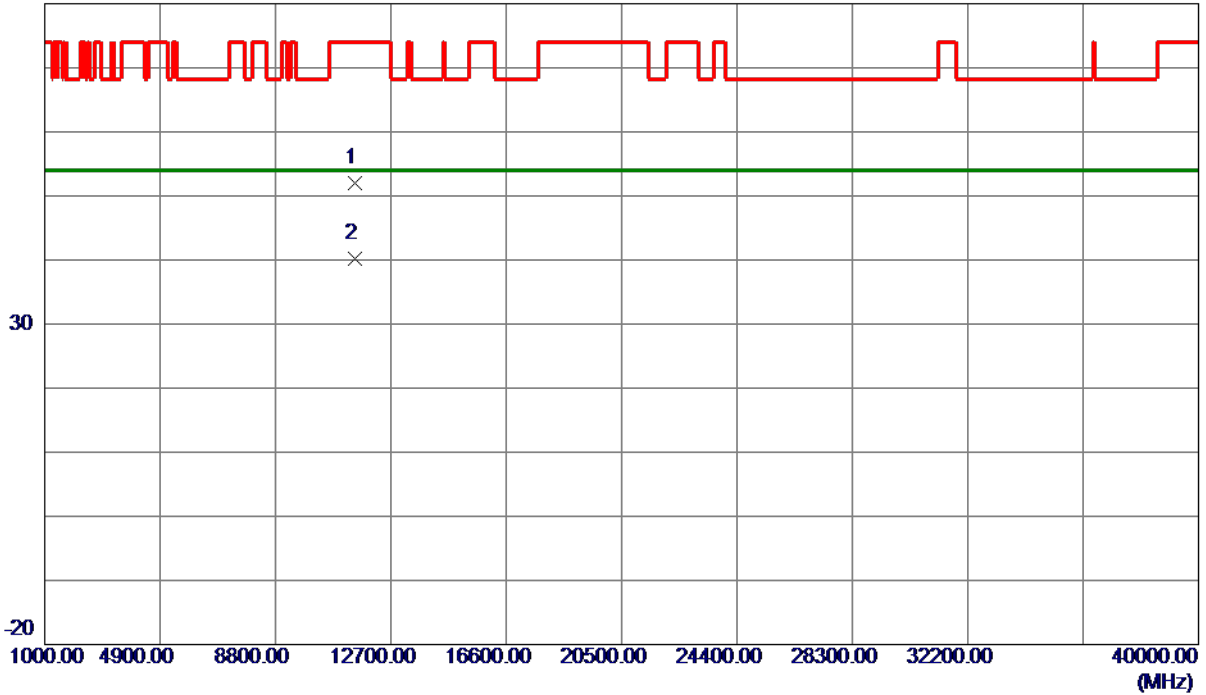

No.	Freq. MHz	Reading Level dBuV/m	Correct Factor dB	Measure ment dBuV/m	Limit dBuV/m	Margin dB	Detector	Comment
1	11483.8400	38.83	13.14	51.97	74.00	-22.03	Peak	
2 *	11494.6200	26.98	13.15	40.13	54.00	-13.87	AVG	

REMARKS:

- (1) Measurement Value = Reading Level + Correct Factor.
- (2) Margin Level = Measurement Value - Limit Value.

Orthogonal Axis	X
Test Mode	UNII-1_TX AC (VHT20) Mode 5180 MHz

Vertical

130 dBuV/m

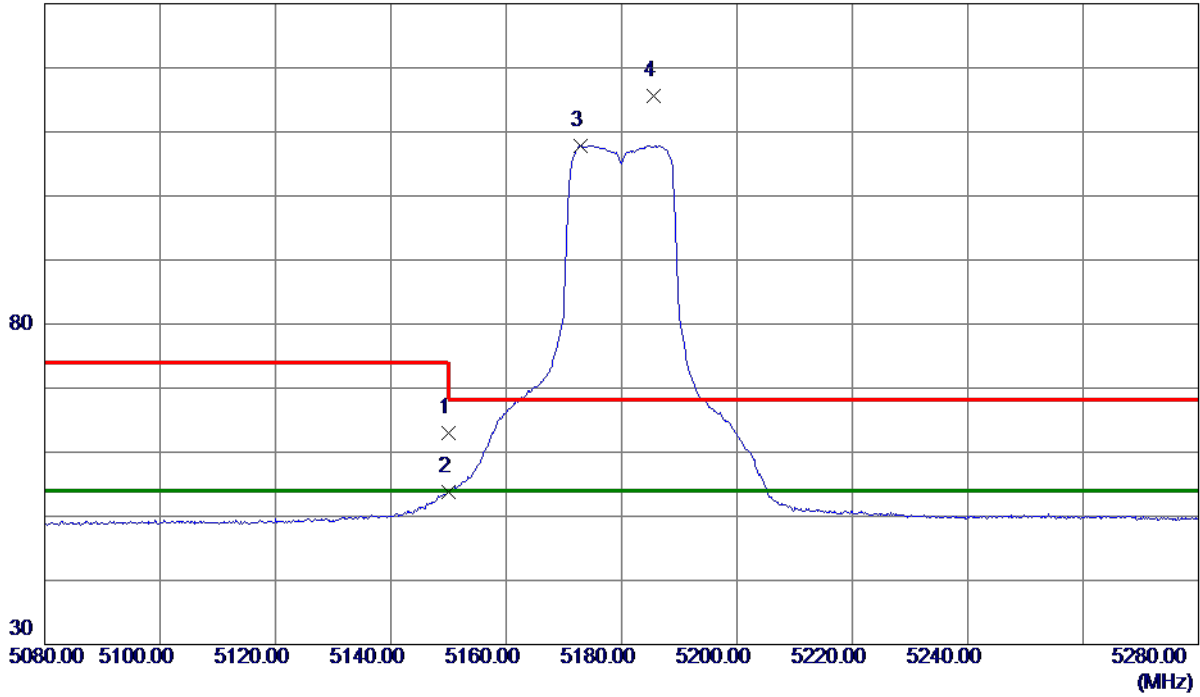

No.	Freq. MHz	Reading Level dBuV/m	Correct Factor dB	Measure ment dBuV/m	Limit dBuV/m	Margin dB	Detector	Comment
1	5150.0000	47.73	15.26	62.99	74.00	-11.01	Peak	
2	5150.0000	38.48	15.26	53.74	54.00	-0.26	AVG	
3 *	5172.9000	92.49	15.32	107.81	54.00	53.81	AVG	No Limit
4	5185.6000	100.26	15.35	115.61	68.30	47.31	Peak	No Limit

REMARKS:

- (1) Measurement Value = Reading Level + Correct Factor.
- (2) Margin Level = Measurement Value - Limit Value.

Orthogonal Axis	X
Test Mode	UNII-1_TX AC (VHT20) Mode 5180 MHz

Vertical

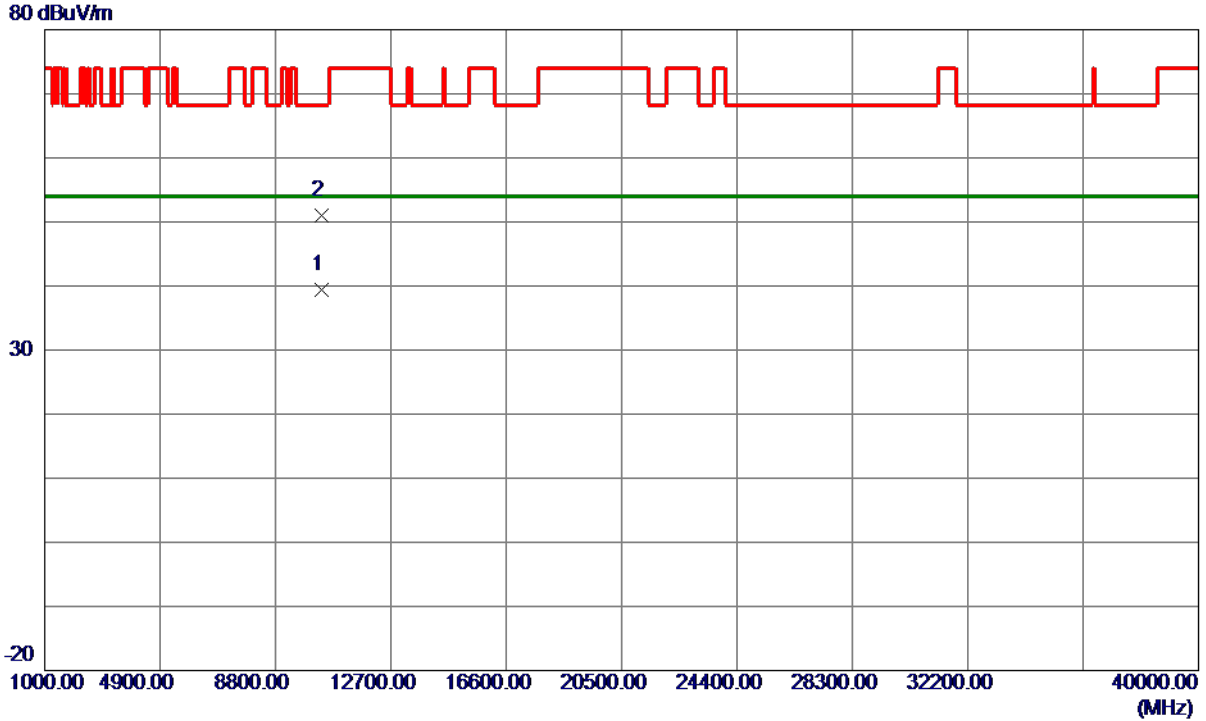

No.	Freq. MHz	Reading Level dBuV/m	Correct Factor dB	Measure ment dBuV/m	Limit dBuV/m	Margin dB	Detector	Comment
1 *	10358.9600	27.20	12.29	39.49	54.00	-14.51	AVG	
2	10366.1000	38.63	12.29	50.92	68.30	-17.38	Peak	

REMARKS:

- (1) Measurement Value = Reading Level + Correct Factor.
- (2) Margin Level = Measurement Value - Limit Value.

Orthogonal Axis	X
Test Mode	UNII-1_TX AC (VHT20) Mode 5180 MHz

Horizontal

130 dBuV/m

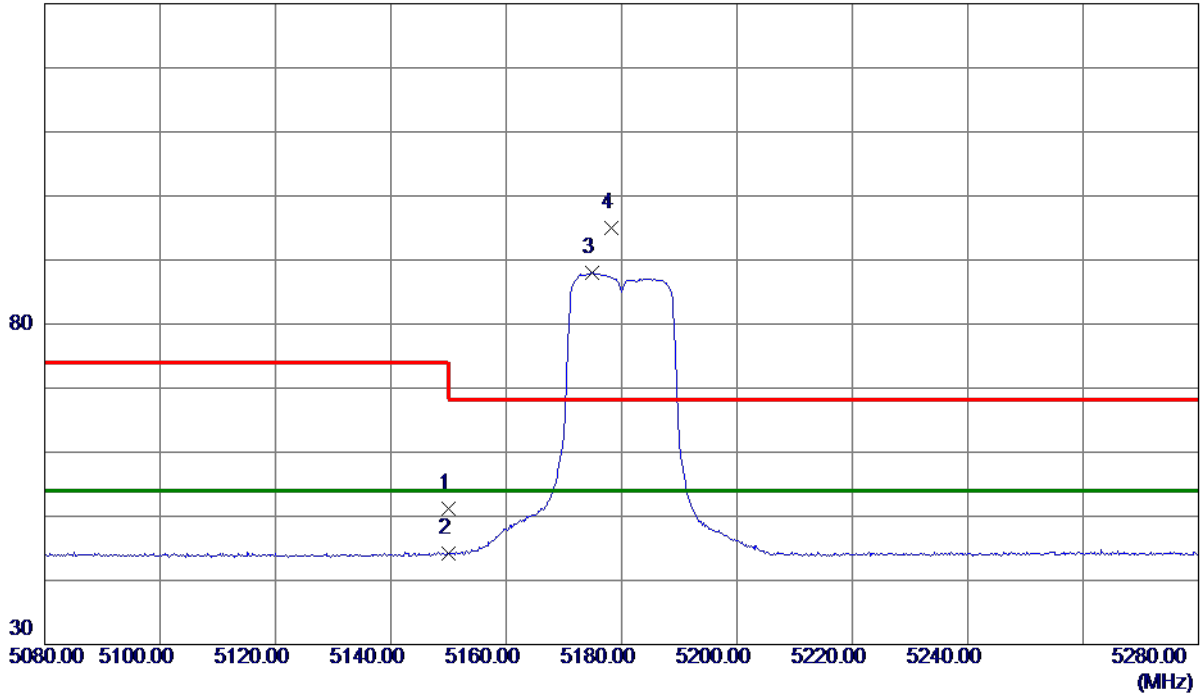

No.	Freq. MHz	Reading Level dBuV/m	Correct Factor dB	Measure ment dBuV/m	Limit dBuV/m	Margin dB	Detector	Comment
1	5150.0000	35.91	15.26	51.17	74.00	-22.83	Peak	
2	5150.0000	28.97	15.26	44.23	54.00	-9.77	AVG	
3 *	5174.8000	72.63	15.32	87.95	54.00	33.95	AVG	No Limit
4	5178.2000	79.69	15.33	95.02	68.30	26.72	Peak	No Limit

REMARKS:

- (1) Measurement Value = Reading Level + Correct Factor.
- (2) Margin Level = Measurement Value - Limit Value.

Orthogonal Axis	X
Test Mode	UNII-1_TX AC (VHT20) Mode 5180 MHz

Horizontal

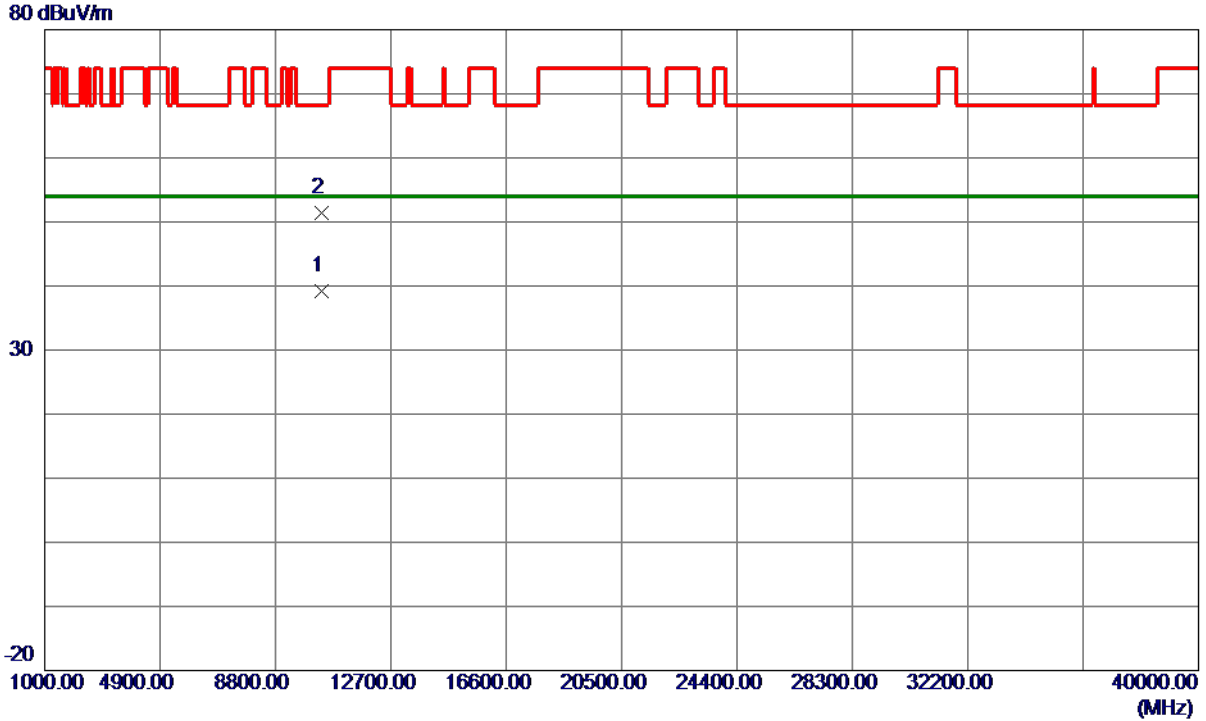

No.	Freq. MHz	Reading Level dBuV/m	Correct Factor dB	Measure ment dBuV/m	Limit dBuV/m	Margin dB	Detector	Comment
1 *	10369.7000	26.97	12.29	39.26	54.00	-14.74	AVG	
2	10369.8400	39.11	12.29	51.40	68.30	-16.90	Peak	

REMARKS:

- (1) Measurement Value = Reading Level + Correct Factor.
- (2) Margin Level = Measurement Value - Limit Value.

Orthogonal Axis	X
Test Mode	UNII-1_TX AC (VHT20) Mode 5200 MHz

Vertical

130 dBuV/m

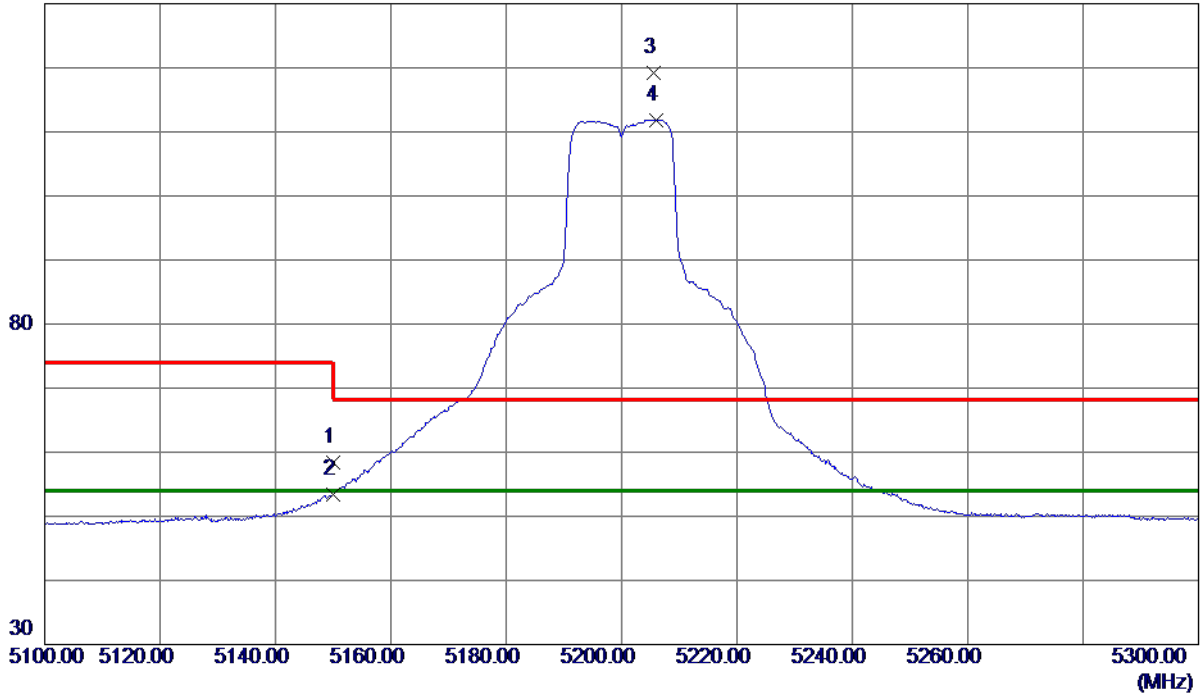

No.	Freq. MHz	Reading Level dBuV/m	Correct Factor dB	Measure ment dBuV/m	Limit dBuV/m	Margin dB	Detector	Comment
1	5150.0000	43.15	15.26	58.41	74.00	-15.59	Peak	
2	5150.0000	38.13	15.26	53.39	54.00	-0.61	AVG	
3	5205.6000	103.80	15.39	119.19	68.30	50.89	Peak	No Limit
4 *	5205.9000	96.48	15.39	111.87	54.00	57.87	AVG	No Limit

REMARKS:

- (1) Measurement Value = Reading Level + Correct Factor.
- (2) Margin Level = Measurement Value - Limit Value.

Orthogonal Axis	X
Test Mode	UNII-1_TX AC (VHT20) Mode 5200 MHz

Vertical

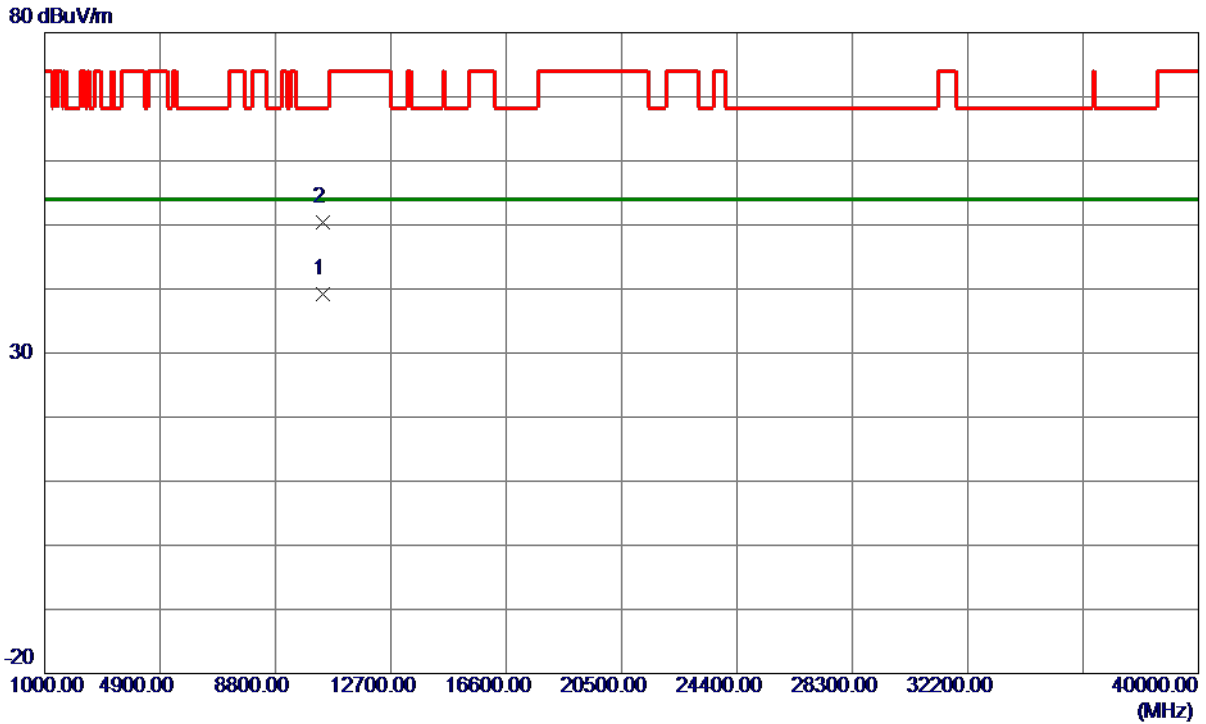

No.	Freq. MHz	Reading Level dBuV/m	Correct Factor dB	Measure ment dBuV/m	Limit dBuV/m	Margin dB	Detector	Comment
1 *	10393.2800	26.95	12.31	39.26	54.00	-14.74	AVG	
2	10396.8000	38.11	12.31	50.42	68.30	-17.88	Peak	

REMARKS:

- (1) Measurement Value = Reading Level + Correct Factor.
- (2) Margin Level = Measurement Value - Limit Value.

Orthogonal Axis	X
Test Mode	UNII-1_TX AC (VHT20) Mode 5200 MHz

Horizontal

130 dBuV/m

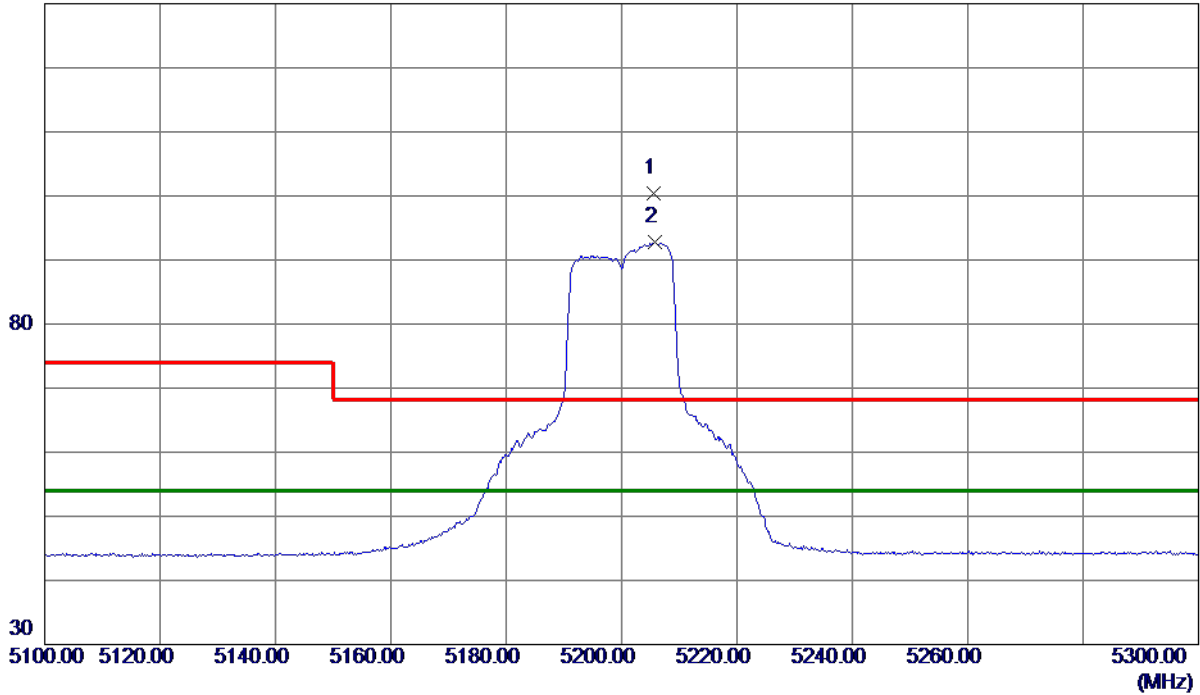

No.	Freq. MHz	Reading Level dBuV/m	Correct Factor dB	Measure ment dBuV/m	Limit dBuV/m	Margin dB	Detector	Comment
1	5205.6000	85.06	15.39	100.45	68.30	32.15	Peak	No Limit
2 *	5205.8000	77.32	15.39	92.71	54.00	38.71	AVG	No Limit

REMARKS:

- (1) Measurement Value = Reading Level + Correct Factor.
- (2) Margin Level = Measurement Value - Limit Value.

Orthogonal Axis	X
Test Mode	UNII-1_TX AC (VHT20) Mode 5200 MHz

Horizontal

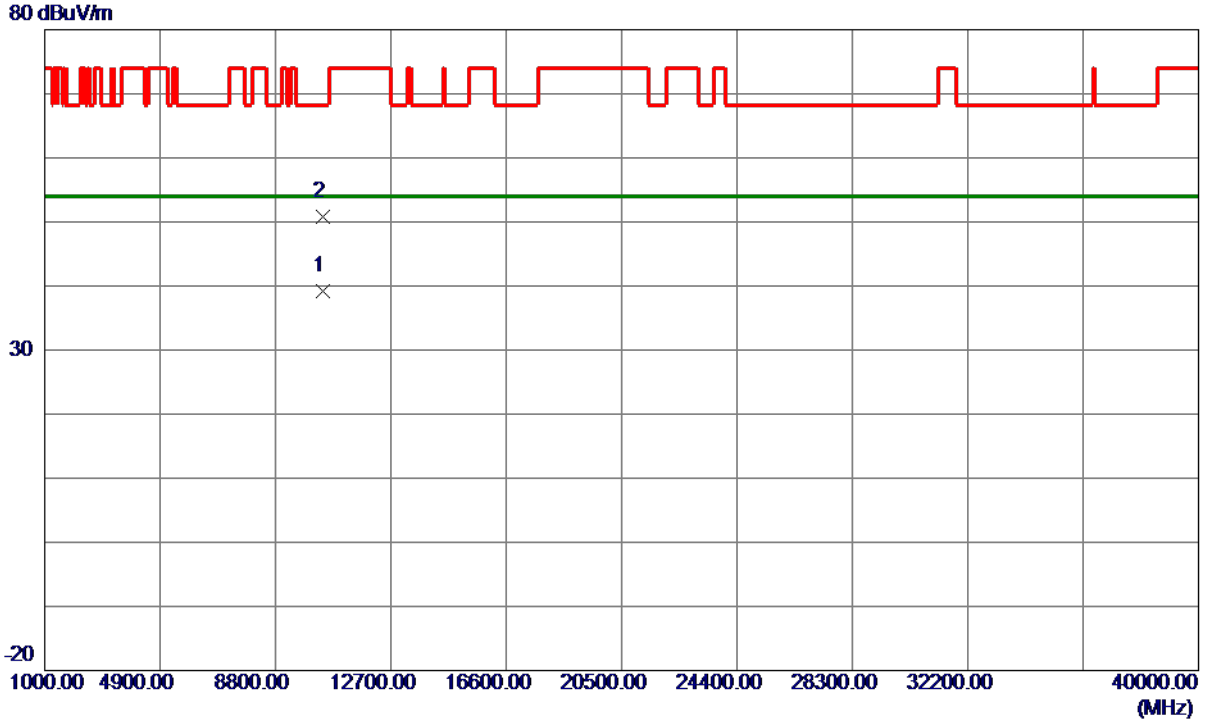

No.	Freq. MHz	Reading Level dBuV/m	Correct Factor dB	Measure ment dBuV/m	Limit dBuV/m	Margin dB	Detector	Comment
1 *	10393.1400	26.91	12.31	39.22	54.00	-14.78	AVG	
2	10409.1200	38.43	12.32	50.75	68.30	-17.55	Peak	

REMARKS:

- (1) Measurement Value = Reading Level + Correct Factor.
- (2) Margin Level = Measurement Value - Limit Value.

Orthogonal Axis	X
Test Mode	UNII-1_TX AC (VHT20) Mode 5240 MHz

Vertical

130 dBuV/m

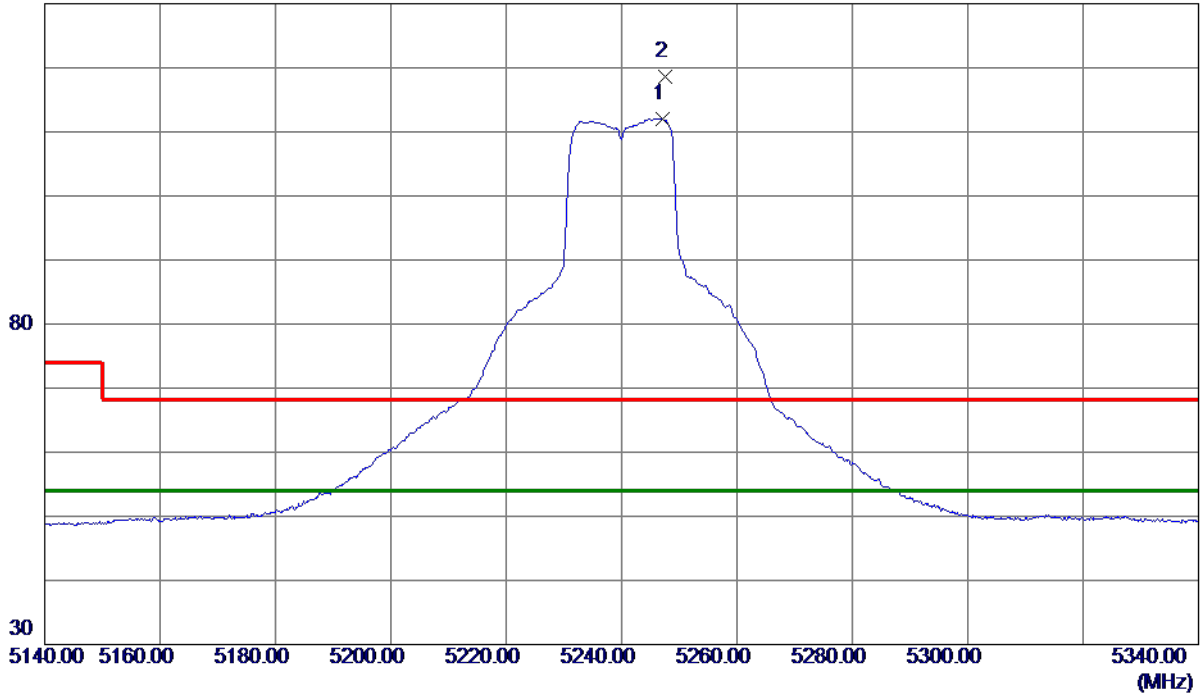

No.	Freq. MHz	Reading Level dBuV/m	Correct Factor dB	Measure ment dBuV/m	Limit dBuV/m	Margin dB	Detector	Comment
1 *	5247.1000	96.60	15.49	112.09	54.00	58.09	AVG	No Limit
2	5247.6000	103.20	15.49	118.69	68.30	50.39	Peak	No Limit

REMARKS:

- (1) Measurement Value = Reading Level + Correct Factor.
- (2) Margin Level = Measurement Value - Limit Value.

Orthogonal Axis	X
Test Mode	UNII-1_TX AC (VHT20) Mode 5240 MHz

Vertical

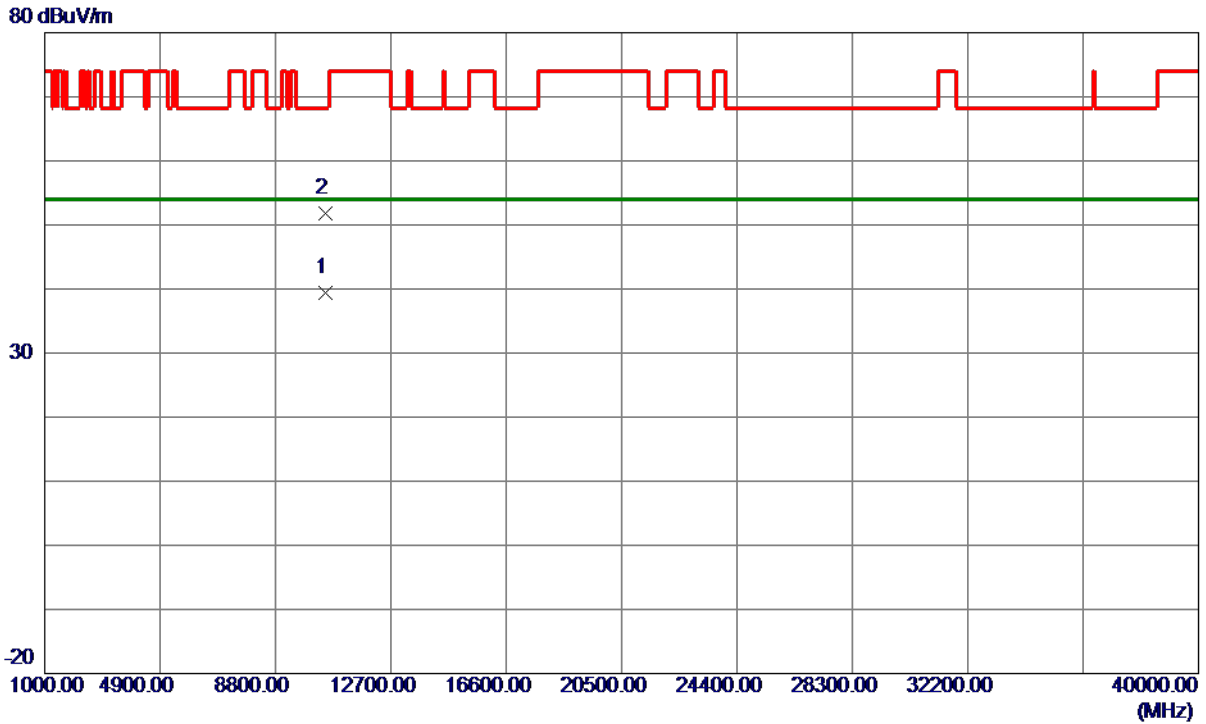

No.	Freq. MHz	Reading Level dBuV/m	Correct Factor dB	Measure ment dBuV/m	Limit dBuV/m	Margin dB	Detector	Comment
1 *	10486.4400	27.03	12.37	39.40	54.00	-14.60	AVG	
2	10487.4000	39.40	12.37	51.77	68.30	-16.53	Peak	

REMARKS:

- (1) Measurement Value = Reading Level + Correct Factor.
- (2) Margin Level = Measurement Value - Limit Value.

Orthogonal Axis	X
Test Mode	UNII-1_TX AC (VHT20) Mode 5240 MHz

Horizontal

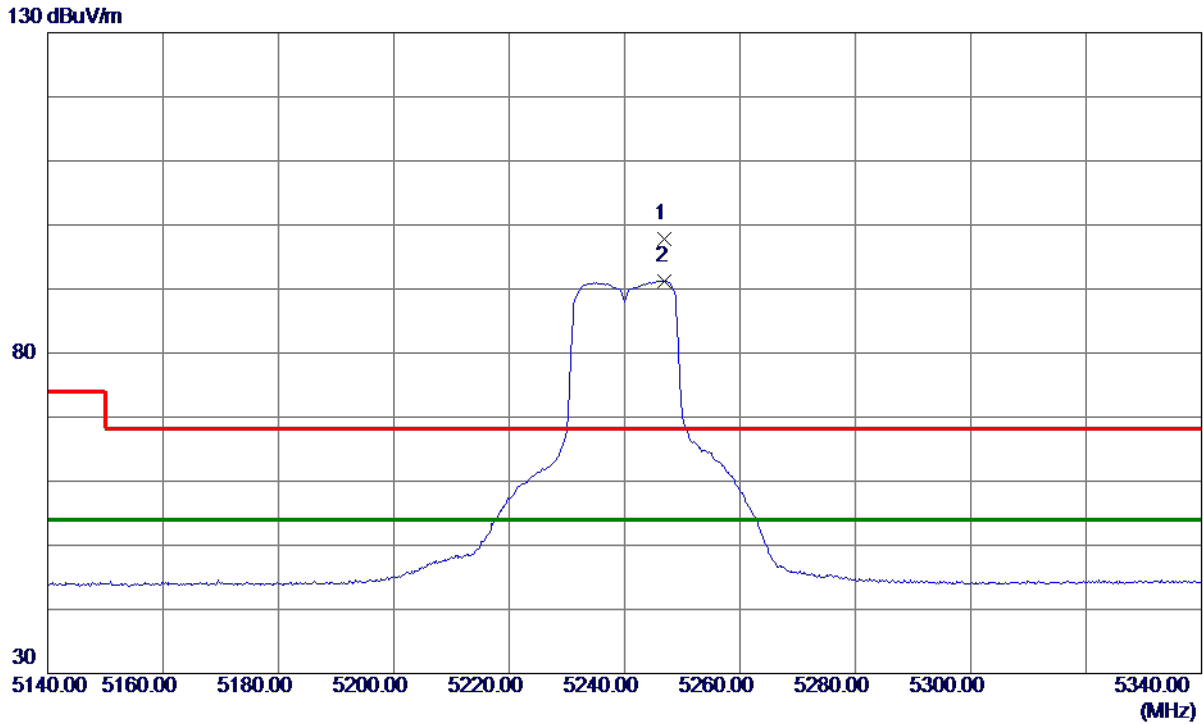

No.	Freq. MHz	Reading Level dBuV/m	Correct Factor dB	Measure ment dBuV/m	Limit dBuV/m	Margin dB	Detector	Comment
1	5246.8000	82.26	15.49	97.75	68.30	29.45	Peak	No Limit
2 *	5247.0000	75.77	15.49	91.26	54.00	37.26	AVG	No Limit

REMARKS:

- (1) Measurement Value = Reading Level + Correct Factor.
- (2) Margin Level = Measurement Value - Limit Value.

Orthogonal Axis	X
Test Mode	UNII-1_TX AC (VHT20) Mode 5240 MHz

Horizontal

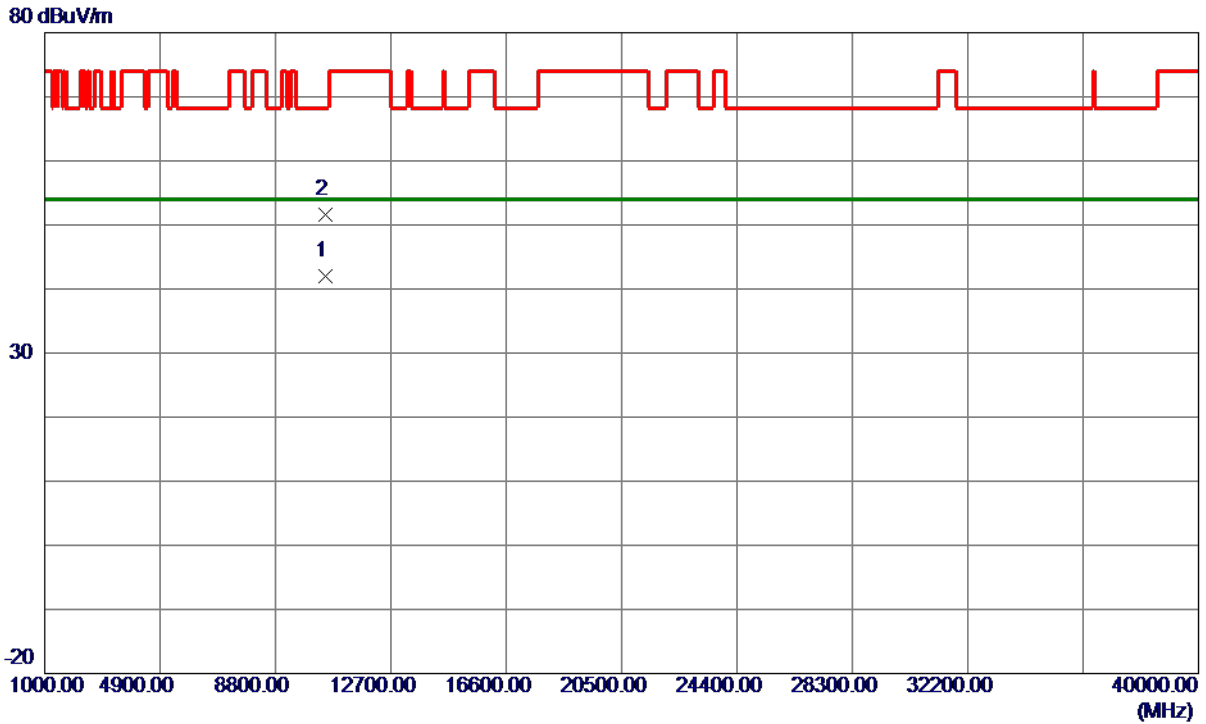

No.	Freq. MHz	Reading Level dBuV/m	Correct Factor dB	Measure ment dBuV/m	Limit dBuV/m	Margin dB	Detector	Comment
1 *	10474.5599	29.69	12.36	42.05	54.00	-11.95	AVG	
2	10489.1600	39.20	12.37	51.57	68.30	-16.73	Peak	

REMARKS:

- (1) Measurement Value = Reading Level + Correct Factor.
- (2) Margin Level = Measurement Value - Limit Value.

Orthogonal Axis	X
Test Mode	UNII-1_TX AC (VHT40) Mode 5190 MHz

Vertical

130 dBuV/m

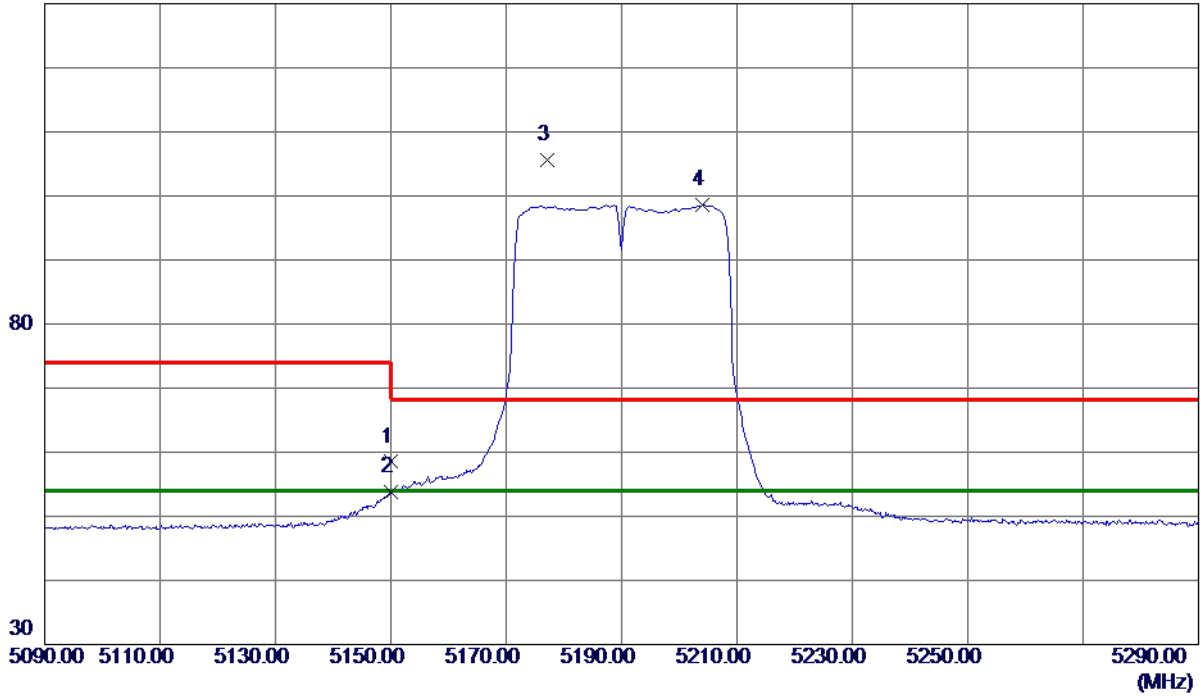

No.	Freq. MHz	Reading Level dBuV/m	Correct Factor dB	Measure ment dBuV/m	Limit dBuV/m	Margin dB	Detector	Comment
1	5150.0000	43.24	15.26	58.50	74.00	-15.50	Peak	
2	5150.0000	38.53	15.26	53.79	54.00	-0.21	AVG	
3	5177.2000	90.29	15.33	105.62	68.30	37.32	Peak	No Limit
4 *	5204.1000	83.22	15.39	98.61	54.00	44.61	AVG	No Limit

REMARKS:

- (1) Measurement Value = Reading Level + Correct Factor.
- (2) Margin Level = Measurement Value - Limit Value.

Orthogonal Axis	X
Test Mode	UNII-1_TX AC (VHT40) Mode 5190 MHz

Vertical

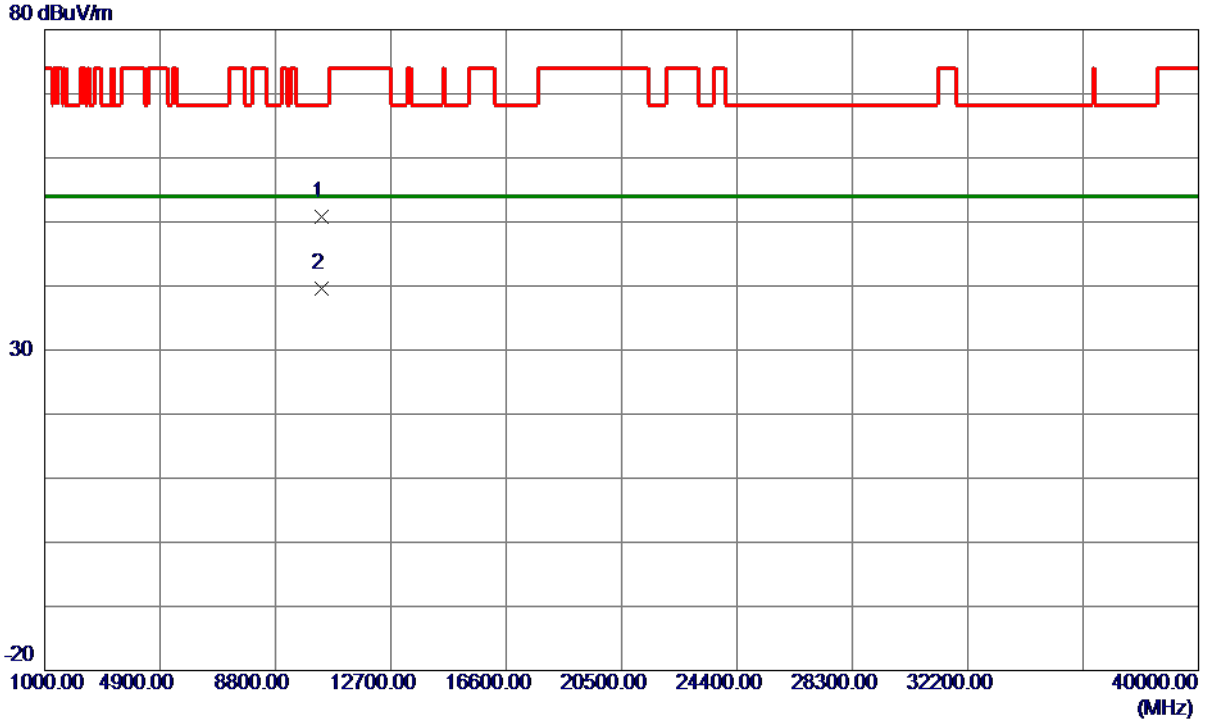

No.	Freq. MHz	Reading Level dBuV/m	Correct Factor dB	Measure ment dBuV/m	Limit dBuV/m	Margin dB	Detector	Comment
1	10378.3450	38.43	12.30	50.73	68.30	-17.57	Peak	
2 *	10379.1800	27.21	12.30	39.51	54.00	-14.49	AVG	

REMARKS:

- (1) Measurement Value = Reading Level + Correct Factor.
- (2) Margin Level = Measurement Value - Limit Value.

Orthogonal Axis	X
Test Mode	UNII-1_TX AC (VHT40) Mode 5190 MHz

Horizontal

130 dBuV/m

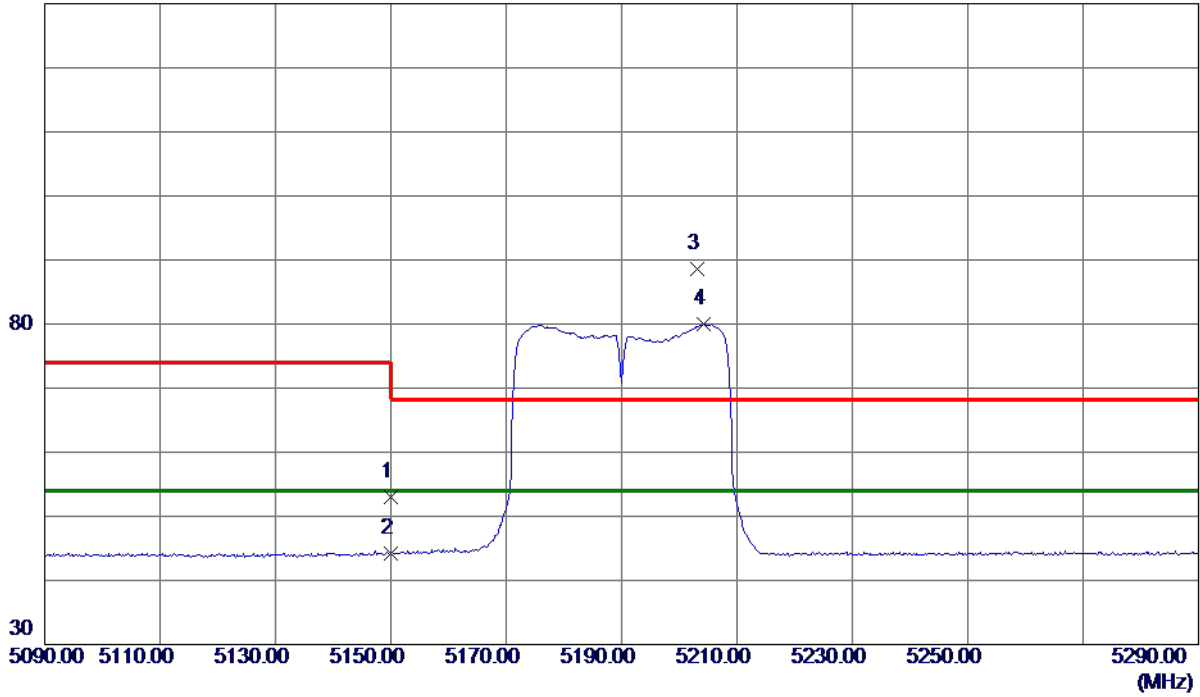

No.	Freq. MHz	Reading Level dBuV/m	Correct Factor dB	Measure ment dBuV/m	Limit dBuV/m	Margin dB	Detector	Comment
1	5150.0000	37.83	15.26	53.09	74.00	-20.91	Peak	
2	5150.0000	28.90	15.26	44.16	54.00	-9.84	AVG	
3	5203.2000	73.17	15.39	88.56	68.30	20.26	Peak	No Limit
4 *	5204.2000	64.56	15.39	79.95	54.00	25.95	AVG	No Limit

REMARKS:

- (1) Measurement Value = Reading Level + Correct Factor.
- (2) Margin Level = Measurement Value - Limit Value.

Orthogonal Axis	X
Test Mode	UNII-1_TX AC (VHT40) Mode 5190 MHz

Horizontal

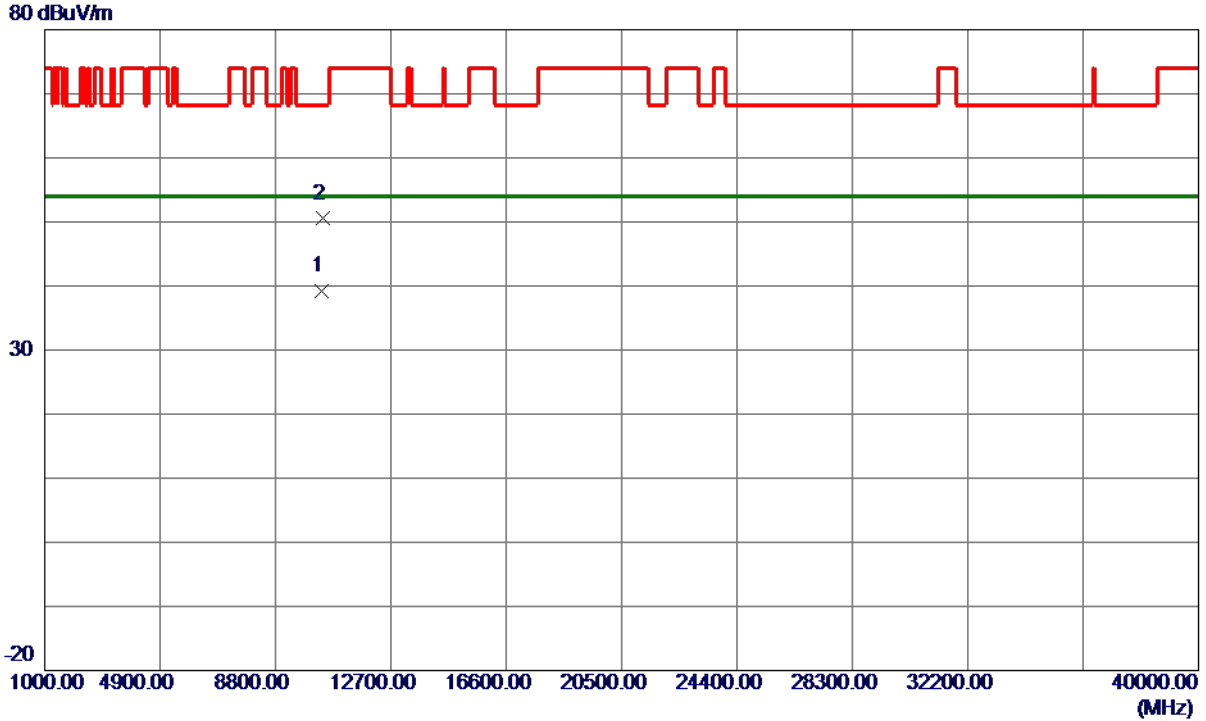

No.	Freq. MHz	Reading Level dBuV/m	Correct Factor dB	Measure ment dBuV/m	Limit dBuV/m	Margin dB	Detector	Comment
1 *	10379.7200	26.95	12.30	39.25	54.00	-14.75	AVG	
2	10382.1650	38.20	12.30	50.50	68.30	-17.80	Peak	

REMARKS:

- (1) Measurement Value = Reading Level + Correct Factor.
- (2) Margin Level = Measurement Value - Limit Value.

Orthogonal Axis	X
Test Mode	UNII-1_TX AC (VHT40) Mode 5230 MHz

Vertical

130 dBuV/m

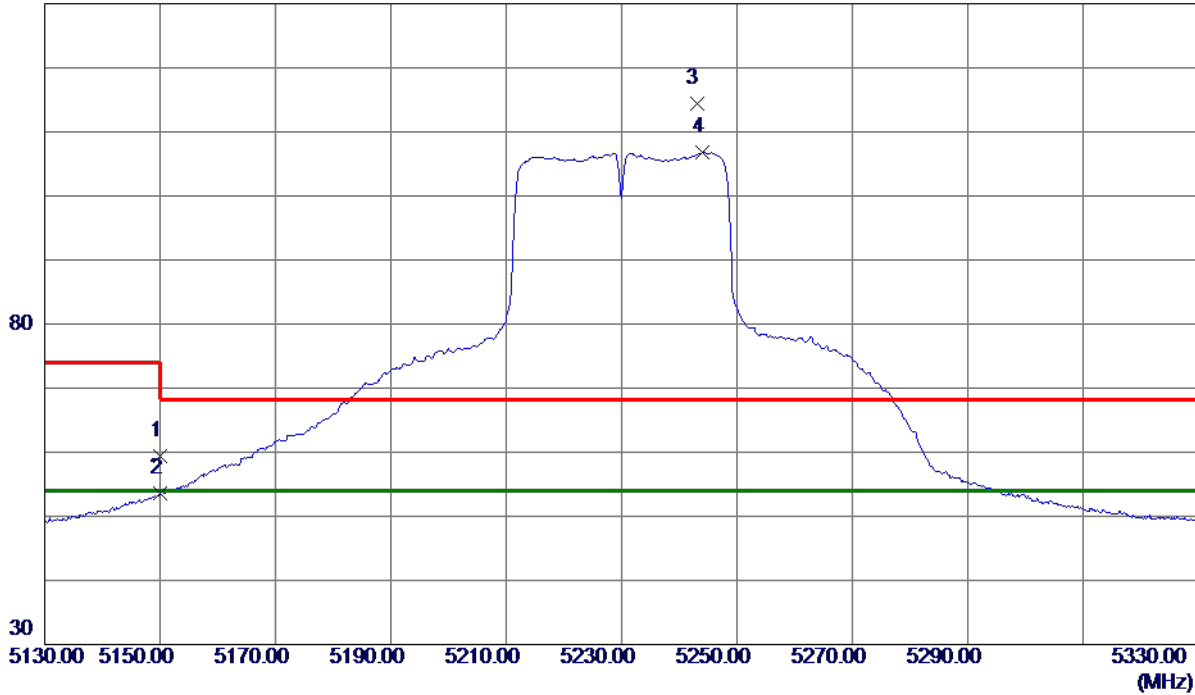

No.	Freq. MHz	Reading Level dBuV/m	Correct Factor dB	Measure ment dBuV/m	Limit dBuV/m	Margin dB	Detector	Comment
1	5150.0000	44.20	15.26	59.46	74.00	-14.54	Peak	
2	5150.0000	38.28	15.26	53.54	54.00	-0.46	AVG	
3	5243.0000	98.98	15.48	114.46	68.30	46.16	Peak	No Limit
4 *	5244.0000	91.27	15.48	106.75	54.00	52.75	AVG	No Limit

REMARKS:

- (1) Measurement Value = Reading Level + Correct Factor.
- (2) Margin Level = Measurement Value - Limit Value.

Orthogonal Axis	X
Test Mode	UNII-1_TX AC (VHT40) Mode 5230 MHz

Vertical

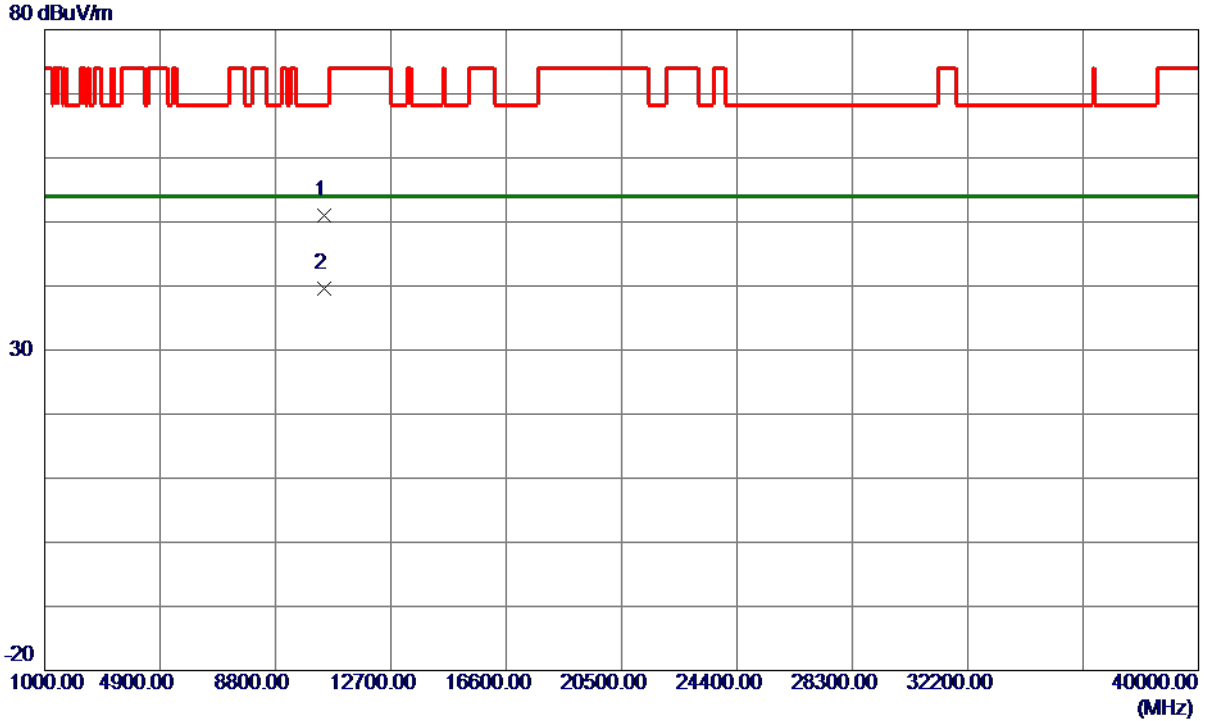

No.	Freq. MHz	Reading Level dBuV/m	Correct Factor dB	Measure ment dBuV/m	Limit dBuV/m	Margin dB	Detector	Comment
1	10457.7150	38.59	12.35	50.94	68.30	-17.36	Peak	
2 *	10462.4250	27.21	12.35	39.56	54.00	-14.44	AVG	

REMARKS:

- (1) Measurement Value = Reading Level + Correct Factor.
- (2) Margin Level = Measurement Value - Limit Value.

Orthogonal Axis	X
Test Mode	UNII-1_TX AC (VHT40) Mode 5230 MHz

Horizontal

130 dBuV/m

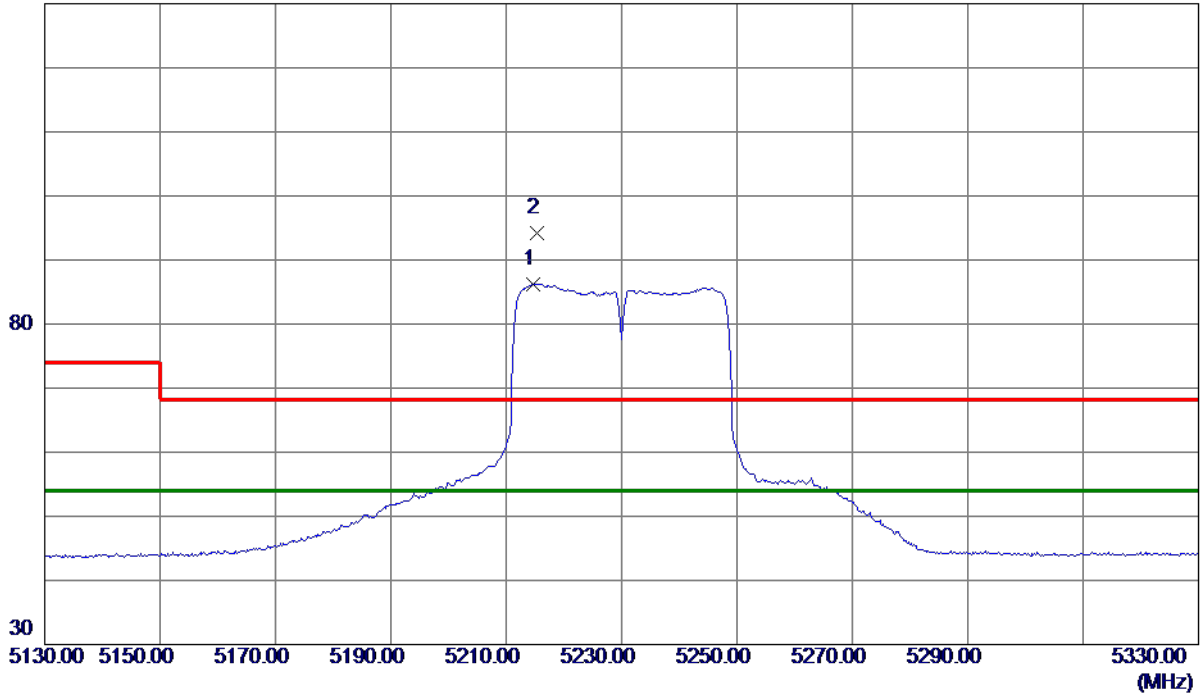

No.	Freq. MHz	Reading Level dBuV/m	Correct Factor dB	Measure ment dBuV/m	Limit dBuV/m	Margin dB	Detector	Comment
1 *	5214.6000	70.83	15.41	86.24	54.00	32.24	AVG	No Limit
2	5215.4000	78.71	15.41	94.12	68.30	25.82	Peak	No Limit

REMARKS:

- (1) Measurement Value = Reading Level + Correct Factor.
- (2) Margin Level = Measurement Value - Limit Value.

Orthogonal Axis	X
Test Mode	UNII-1_TX AC (VHT40) Mode 5230 MHz

Horizontal

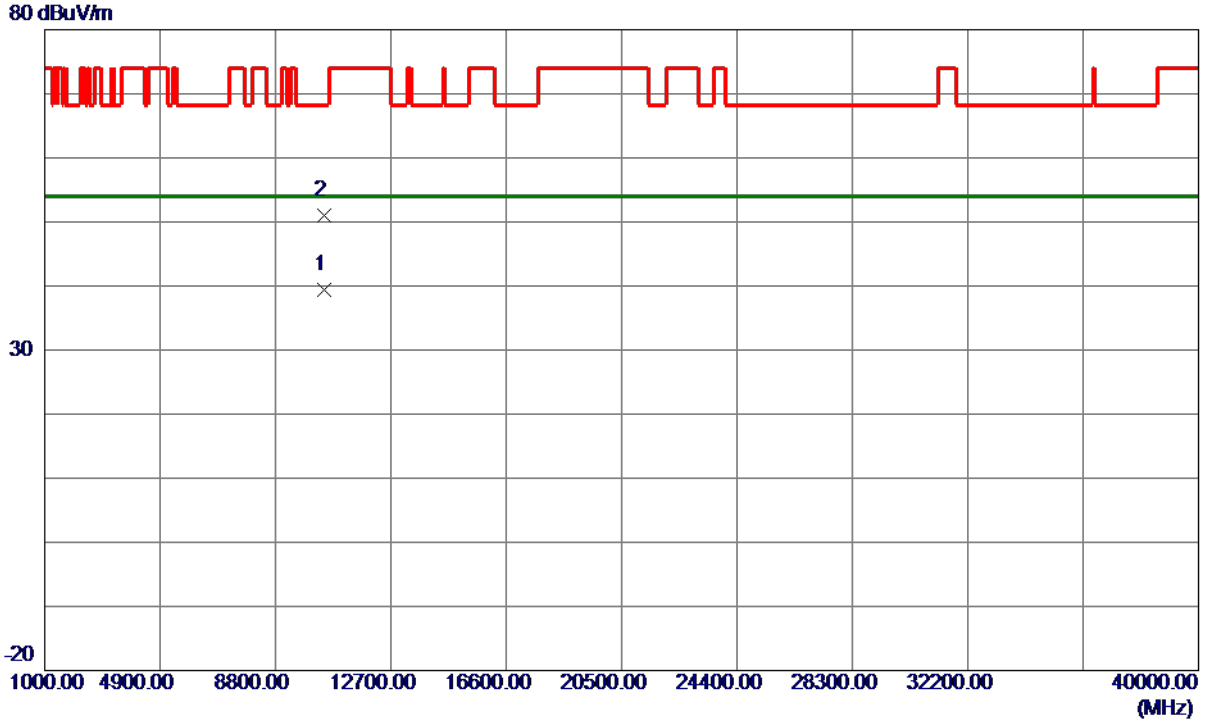

No.	Freq. MHz	Reading Level dBuV/m	Correct Factor dB	Measure ment dBuV/m	Limit dBuV/m	Margin dB	Detector	Comment
1 *	10459.2200	26.99	12.35	39.34	54.00	-14.66	AVG	
2	10462.4450	38.73	12.35	51.08	68.30	-17.22	Peak	

REMARKS:

- (1) Measurement Value = Reading Level + Correct Factor.
- (2) Margin Level = Measurement Value - Limit Value.

Orthogonal Axis	X
Test Mode	UNII-1_TX AC (VHT80) Mode 5210 MHz

Vertical

130 dBuV/m

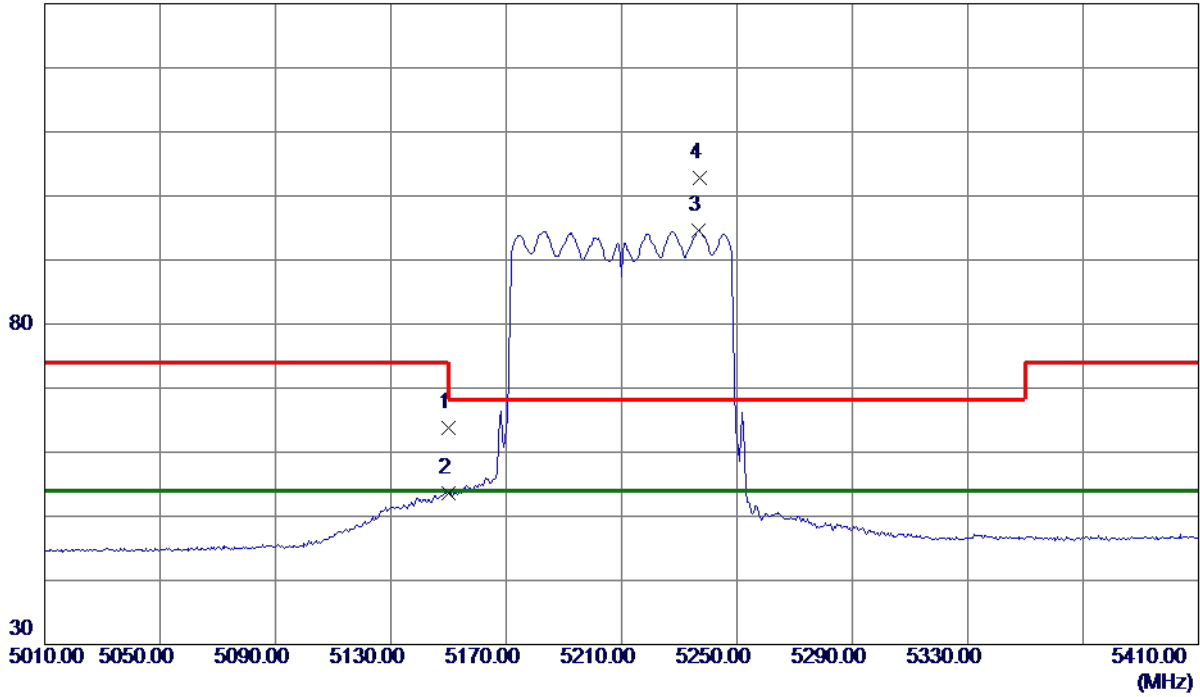

No.	Freq. MHz	Reading Level dBuV/m	Correct Factor dB	Measure ment dBuV/m	Limit dBuV/m	Margin dB	Detector	Comment
1	5150.0000	48.55	15.26	63.81	74.00	-10.19	Peak	
2	5150.0000	38.43	15.26	53.69	54.00	-0.31	AVG	
3 *	5236.8000	79.14	15.46	94.60	54.00	40.60	AVG	No Limit
4	5237.2000	87.36	15.46	102.82	68.30	34.52	Peak	No Limit

REMARKS:

- (1) Measurement Value = Reading Level + Correct Factor.
- (2) Margin Level = Measurement Value - Limit Value.

Orthogonal Axis	X
Test Mode	UNII-1_TX AC (VHT80) Mode 5210 MHz

Vertical

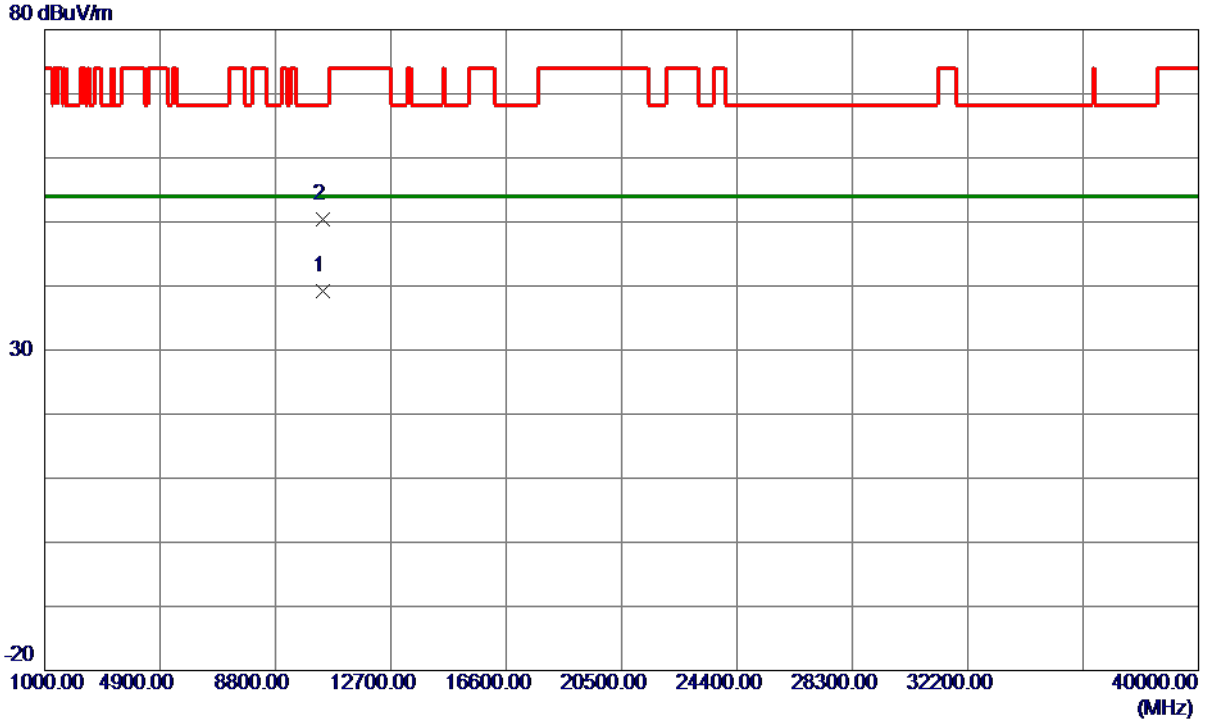

No.	Freq. MHz	Reading Level dBuV/m	Correct Factor dB	Measure ment dBuV/m	Limit dBuV/m	Margin dB	Detector	Comment
1 *	10420.9200	26.81	12.33	39.14	54.00	-14.86	AVG	
2	10422.1350	38.07	12.33	50.40	68.30	-17.90	Peak	

REMARKS:

- (1) Measurement Value = Reading Level + Correct Factor.
- (2) Margin Level = Measurement Value - Limit Value.

Orthogonal Axis	X
Test Mode	UNII-1_TX AC (VHT80) Mode 5210 MHz

Horizontal

130 dBuV/m

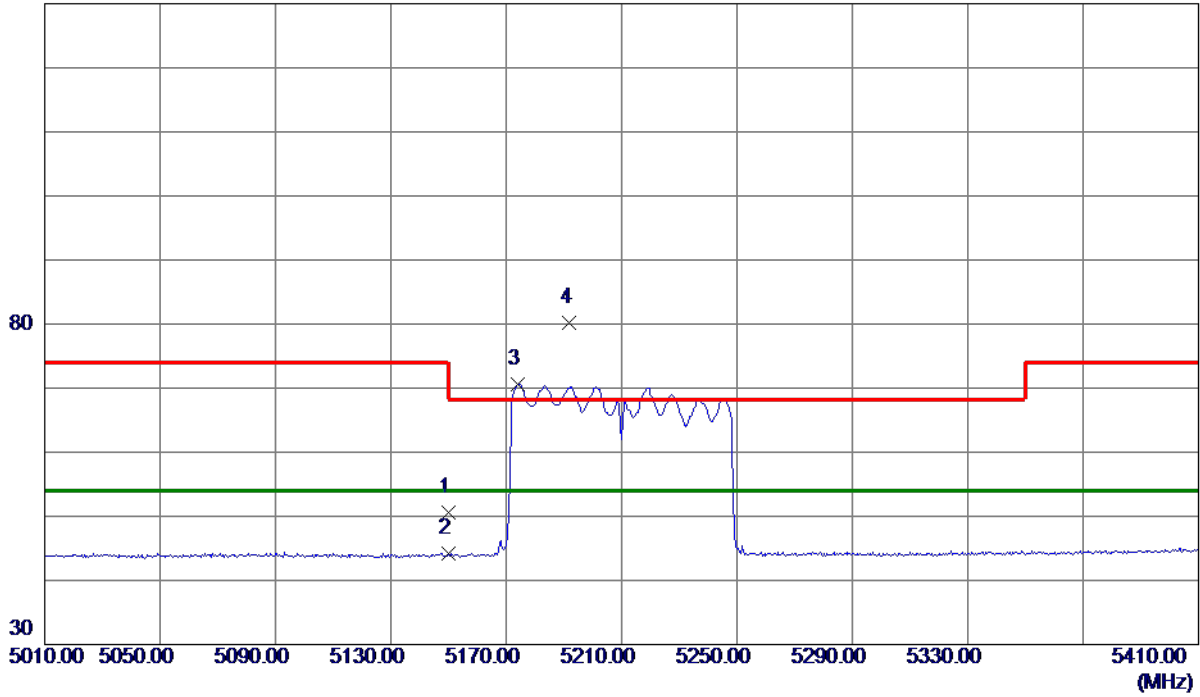

No.	Freq. MHz	Reading Level dBuV/m	Correct Factor dB	Measure ment dBuV/m	Limit dBuV/m	Margin dB	Detector	Comment
1	5150.0000	35.31	15.26	50.57	74.00	-23.43	Peak	
2	5150.0000	28.96	15.26	44.22	54.00	-9.78	AVG	
3 *	5174.0000	55.36	15.32	70.68	54.00	16.68	AVG	No Limit
4	5192.0000	64.75	15.36	80.11	68.30	11.81	Peak	No Limit

REMARKS:

- (1) Measurement Value = Reading Level + Correct Factor.
- (2) Margin Level = Measurement Value - Limit Value.

Orthogonal Axis	X
Test Mode	UNII-1_TX AC (VHT80) Mode 5210 MHz

Horizontal

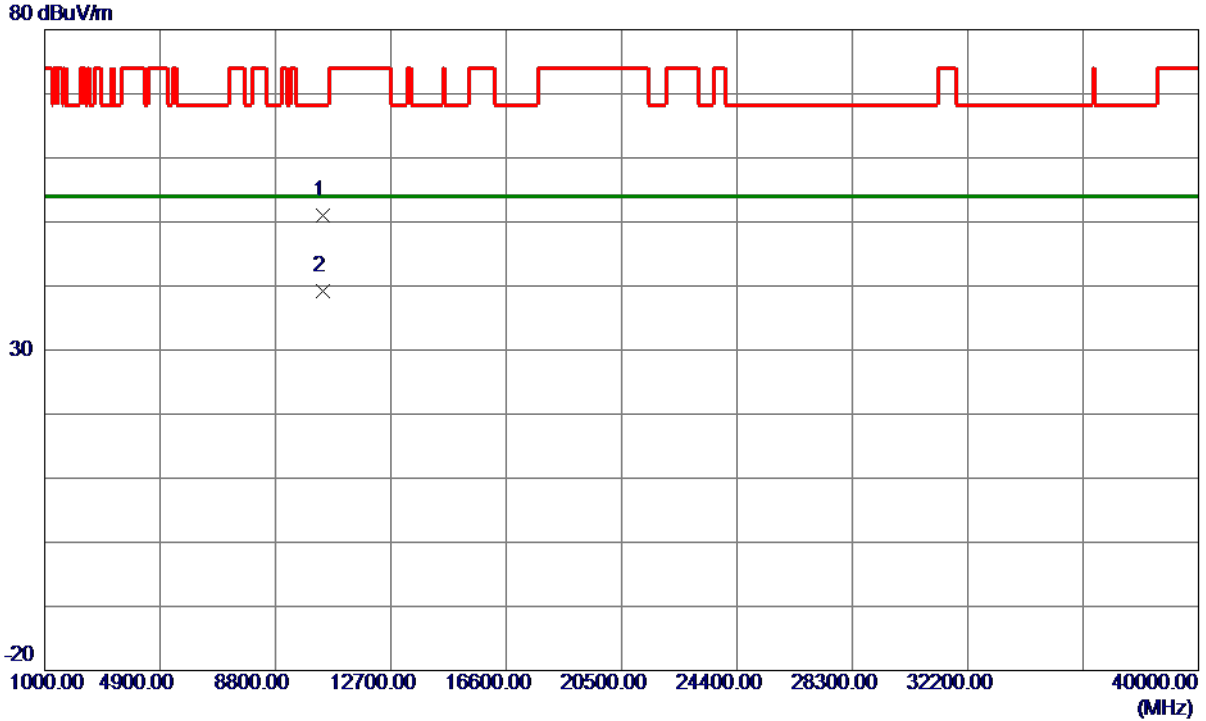

No.	Freq. MHz	Reading Level dBuV/m	Correct Factor dB	Measure ment dBuV/m	Limit dBuV/m	Margin dB	Detector	Comment
1	10421.4300	38.71	12.33	51.04	68.30	-17.26	Peak	
2 *	10421.7750	26.80	12.33	39.13	54.00	-14.87	AVG	

REMARKS:

- (1) Measurement Value = Reading Level + Correct Factor.
- (2) Margin Level = Measurement Value - Limit Value.

Orthogonal Axis	X
Test Mode	UNII-2A_TX AC (VHT20) Mode 5260 MHz

Vertical

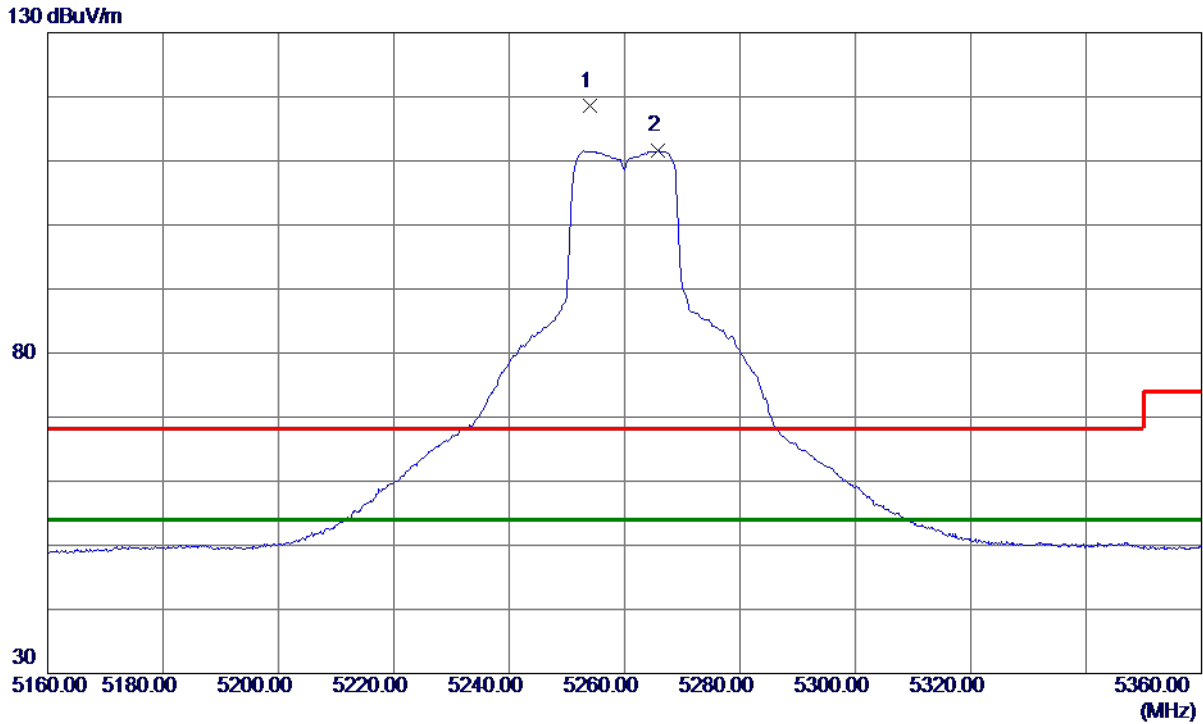

No.	Freq. MHz	Reading Level dBuV/m	Correct Factor dB	Measure ment dBuV/m	Limit dBuV/m	Margin dB	Detector	Comment
1	5254.0000	103.00	15.50	118.50	68.30	50.20	Peak	No Limit
2 *	5265.8000	96.05	15.53	111.58	54.00	57.58	AVG	No Limit

REMARKS:

- (1) Measurement Value = Reading Level + Correct Factor.
- (2) Margin Level = Measurement Value - Limit Value.

Orthogonal Axis	X
Test Mode	UNII-2A_TX AC (VHT20) Mode 5260 MHz

Vertical

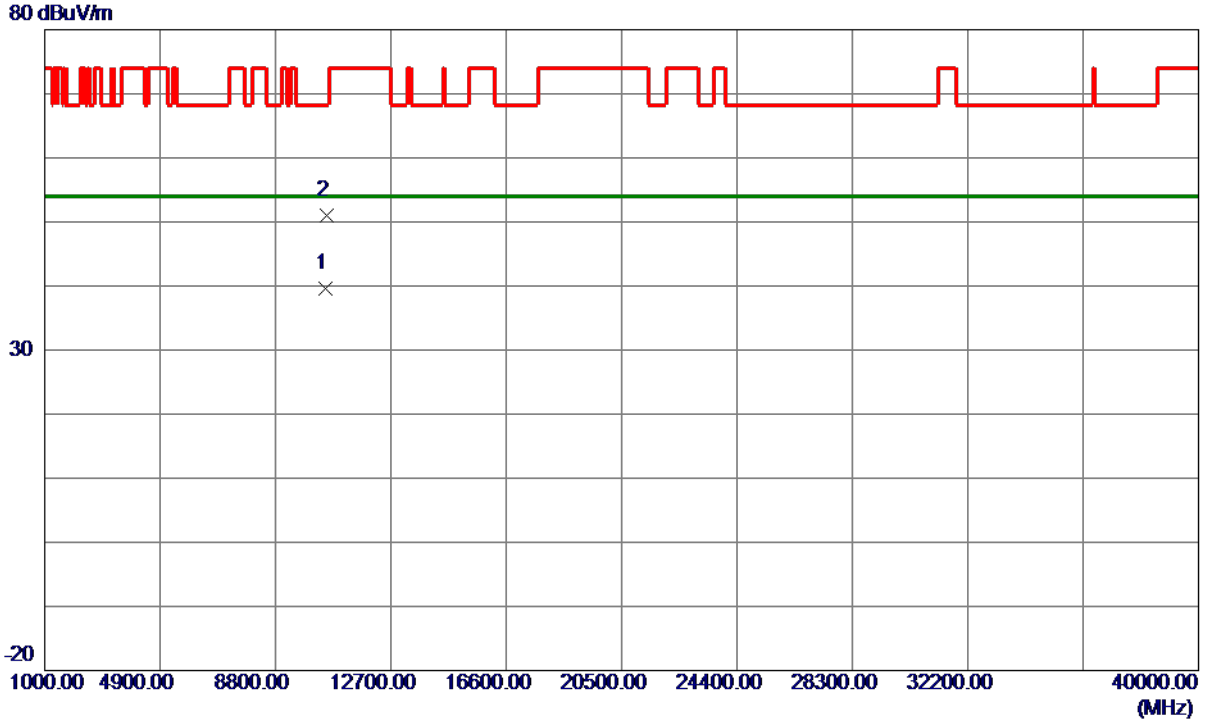

No.	Freq. MHz	Reading Level dBuV/m	Correct Factor dB	Measure ment dBuV/m	Limit dBuV/m	Margin dB	Detector	Comment
1 *	10510.3200	27.30	12.38	39.68	54.00	-14.32	AVG	
2	10529.1400	38.66	12.40	51.06	68.30	-17.24	Peak	

REMARKS:

- (1) Measurement Value = Reading Level + Correct Factor.
- (2) Margin Level = Measurement Value - Limit Value.

Orthogonal Axis	X
Test Mode	UNII-2A_TX AC (VHT20) Mode 5260 MHz

Horizontal

130 dBuV/m

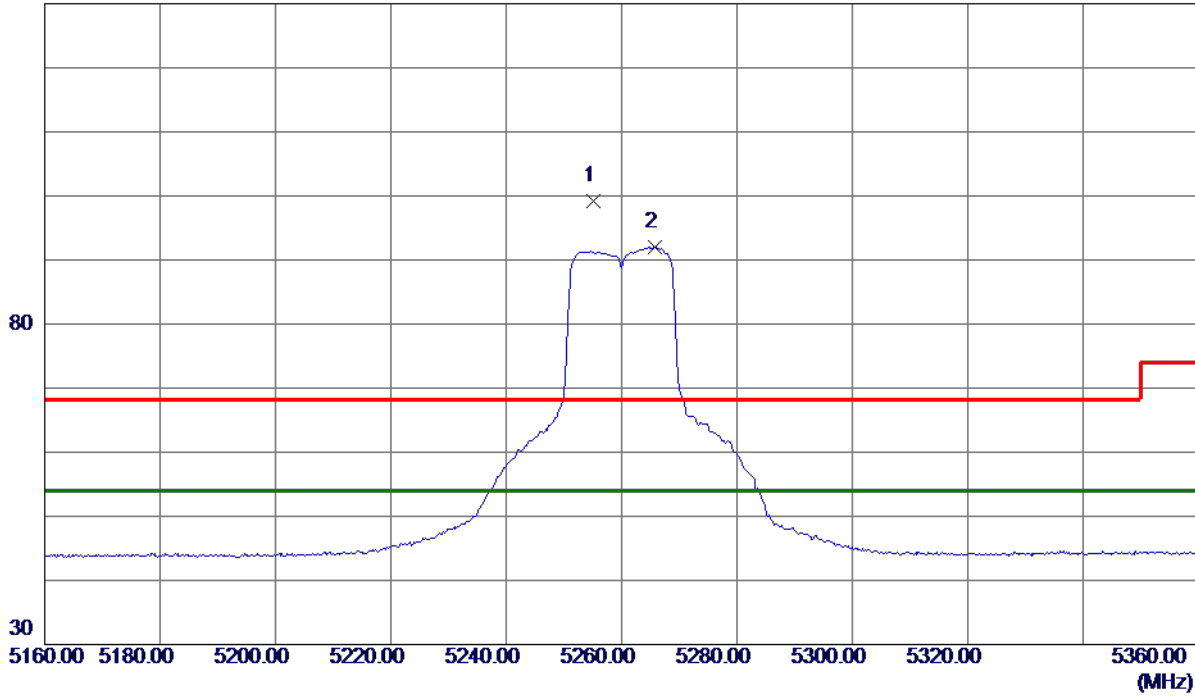

No.	Freq. MHz	Reading Level dBuV/m	Correct Factor dB	Measure ment dBuV/m	Limit dBuV/m	Margin dB	Detector	Comment
1	5255.2000	83.72	15.50	99.22	68.30	30.92	Peak	No Limit
2 *	5265.8000	76.40	15.53	91.93	54.00	37.93	AVG	No Limit

REMARKS:

- (1) Measurement Value = Reading Level + Correct Factor.
- (2) Margin Level = Measurement Value - Limit Value.

Orthogonal Axis	X
Test Mode	UNII-2A_TX AC (VHT20) Mode 5260 MHz

Horizontal

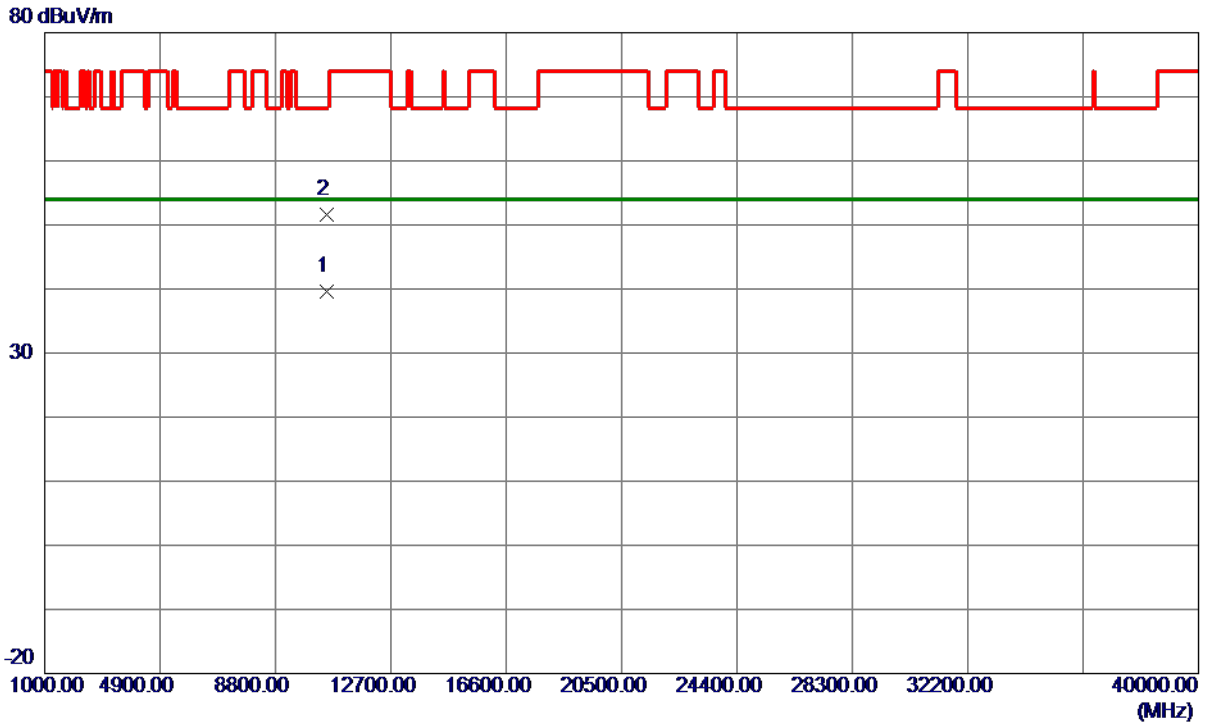

No.	Freq. MHz	Reading Level dBuV/m	Correct Factor dB	Measure ment dBuV/m	Limit dBuV/m	Margin dB	Detector	Comment
1 *	10514.9200	27.16	12.39	39.55	54.00	-14.45	AVG	
2	10526.5599	39.12	12.40	51.52	68.30	-16.78	Peak	

REMARKS:

- (1) Measurement Value = Reading Level + Correct Factor.
- (2) Margin Level = Measurement Value - Limit Value.

Orthogonal Axis	X
Test Mode	UNII-2A_TX AC (VHT20) Mode 5300 MHz

Vertical

130 dBuV/m

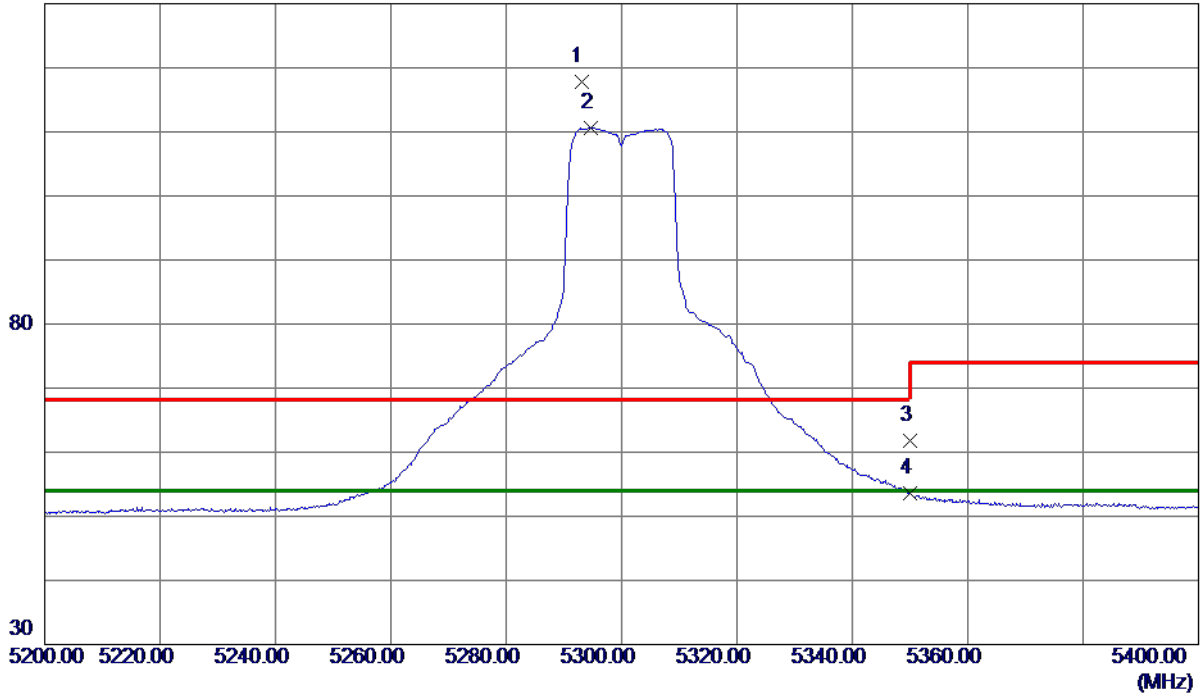

No.	Freq. MHz	Reading Level dBuV/m	Correct Factor dB	Measure ment dBuV/m	Limit dBuV/m	Margin dB	Detector	Comment
1	5293.0000	102.14	15.59	117.73	68.30	49.43	Peak	No Limit
2 *	5294.7000	95.01	15.59	110.60	54.00	56.60	AVG	No Limit
3	5350.0000	46.16	15.72	61.88	74.00	-12.12	Peak	
4	5350.0000	37.86	15.72	53.58	54.00	-0.42	AVG	

REMARKS:

- (1) Measurement Value = Reading Level + Correct Factor.
- (2) Margin Level = Measurement Value - Limit Value.

Orthogonal Axis	X
Test Mode	UNII-2A_TX AC (VHT20) Mode 5300 MHz

Vertical

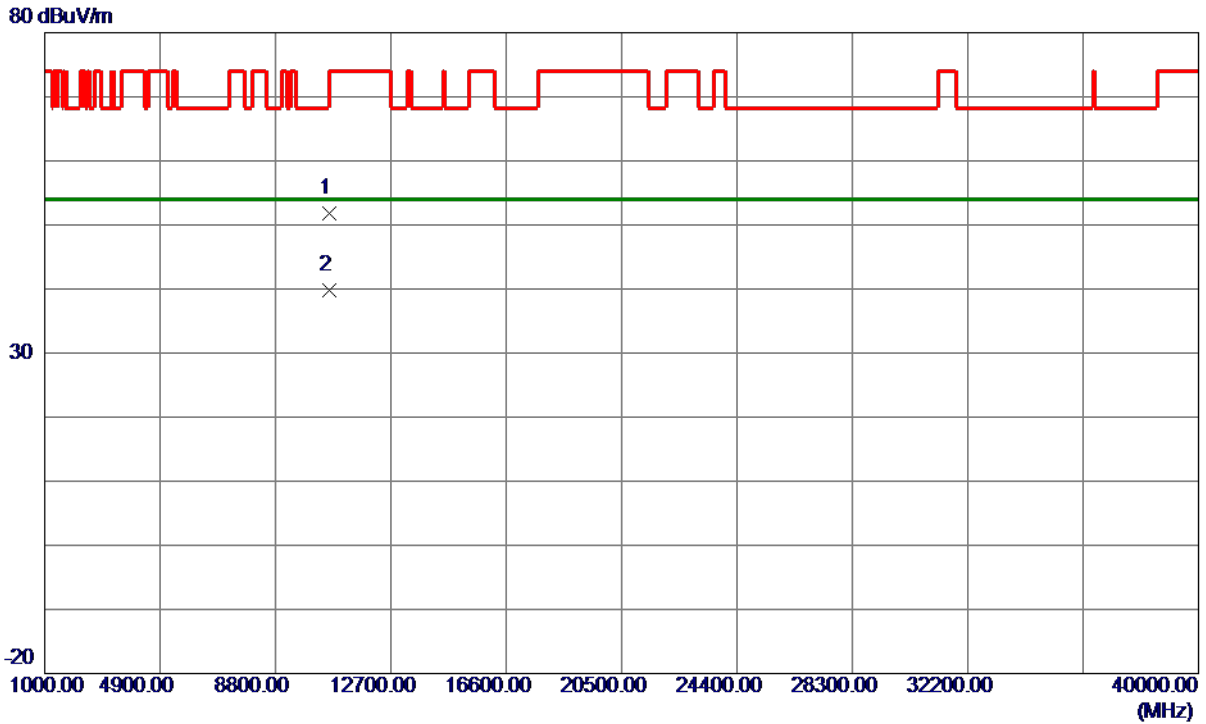

No.	Freq. MHz	Reading Level dBuV/m	Correct Factor dB	Measure ment dBuV/m	Limit dBuV/m	Margin dB	Detector	Comment
1	10608.5199	39.32	12.46	51.78	74.00	-22.22	Peak	
2 *	10609.3000	27.41	12.46	39.87	54.00	-14.13	AVG	

REMARKS:

- (1) Measurement Value = Reading Level + Correct Factor.
- (2) Margin Level = Measurement Value - Limit Value.

Orthogonal Axis	X
Test Mode	UNII-2A_TX AC (VHT20) Mode 5300 MHz

Horizontal

130 dBuV/m

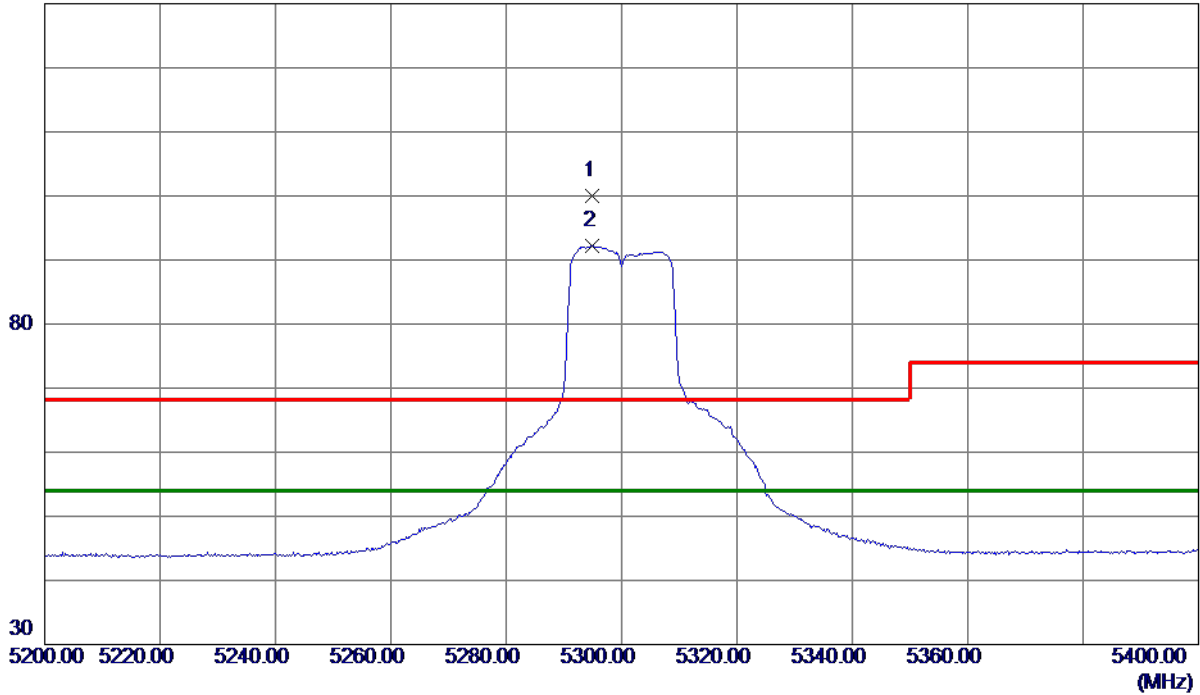

No.	Freq. MHz	Reading Level dBuV/m	Correct Factor dB	Measure ment dBuV/m	Limit dBuV/m	Margin dB	Detector	Comment
1	5295.0000	84.42	15.60	100.02	68.30	31.72	Peak	No Limit
2 *	5295.0000	76.53	15.60	92.13	54.00	38.13	AVG	No Limit

REMARKS:

- (1) Measurement Value = Reading Level + Correct Factor.
- (2) Margin Level = Measurement Value - Limit Value.

Orthogonal Axis	X
Test Mode	UNII-2A_TX AC (VHT20) Mode 5300 MHz

Horizontal

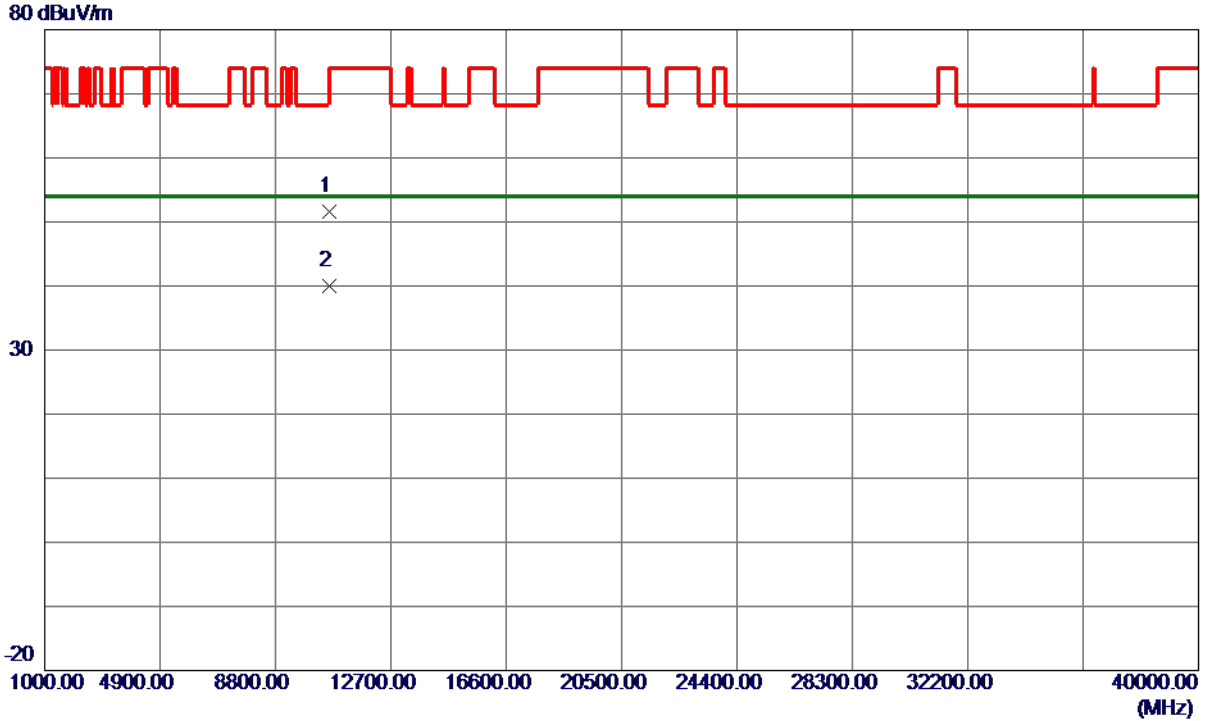

No.	Freq. MHz	Reading Level dBuV/m	Correct Factor dB	Measure ment dBuV/m	Limit dBuV/m	Margin dB	Detector	Comment
1	10598.9600	39.08	12.46	51.54	68.30	-16.76	Peak	
2 *	10608.1800	27.51	12.46	39.97	54.00	-14.03	AVG	

REMARKS:

- (1) Measurement Value = Reading Level + Correct Factor.
- (2) Margin Level = Measurement Value - Limit Value.

Orthogonal Axis	X
Test Mode	UNII-2A_TX AC (VHT20) Mode 5320 MHz

Vertical

130 dBuV/m

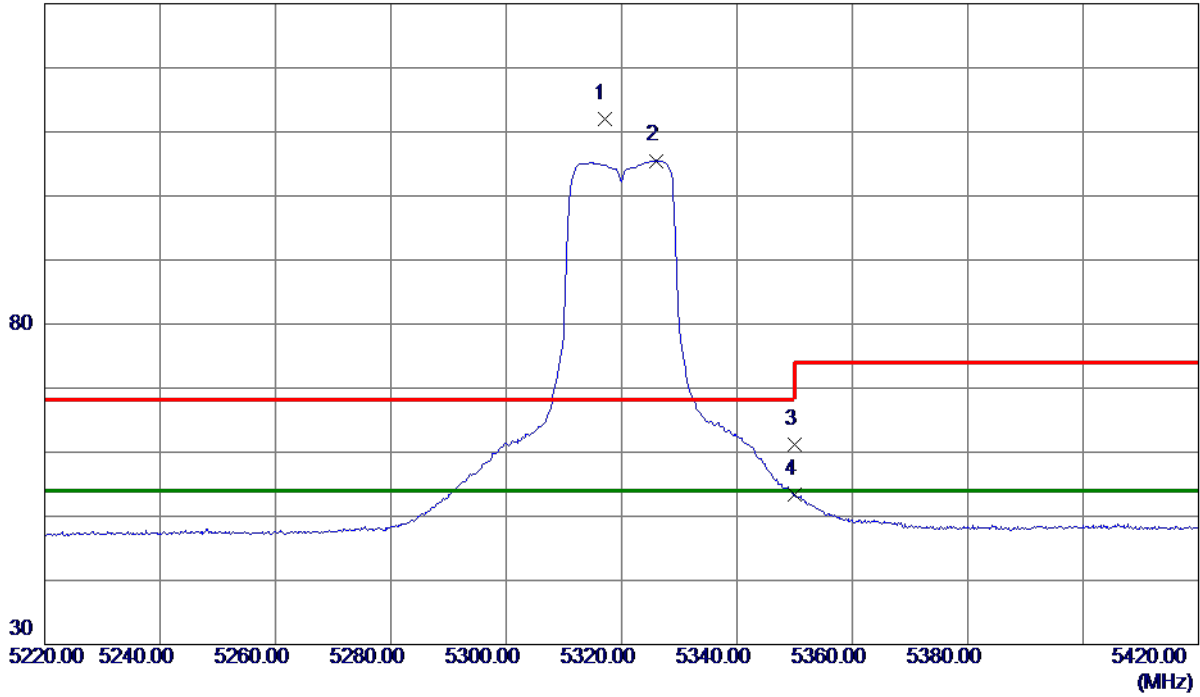

No.	Freq. MHz	Reading Level dBuV/m	Correct Factor dB	Measure ment dBuV/m	Limit dBuV/m	Margin dB	Detector	Comment
1	5317.0000	96.42	15.65	112.07	68.30	43.77	Peak	No Limit
2 *	5325.9000	89.83	15.67	105.50	54.00	51.50	AVG	No Limit
3	5350.0000	45.40	15.72	61.12	74.00	-12.88	Peak	
4	5350.0000	37.68	15.72	53.40	54.00	-0.60	AVG	

REMARKS:

- (1) Measurement Value = Reading Level + Correct Factor.
- (2) Margin Level = Measurement Value - Limit Value.

Orthogonal Axis	X
Test Mode	UNII-2A_TX AC (VHT20) Mode 5320 MHz

Vertical

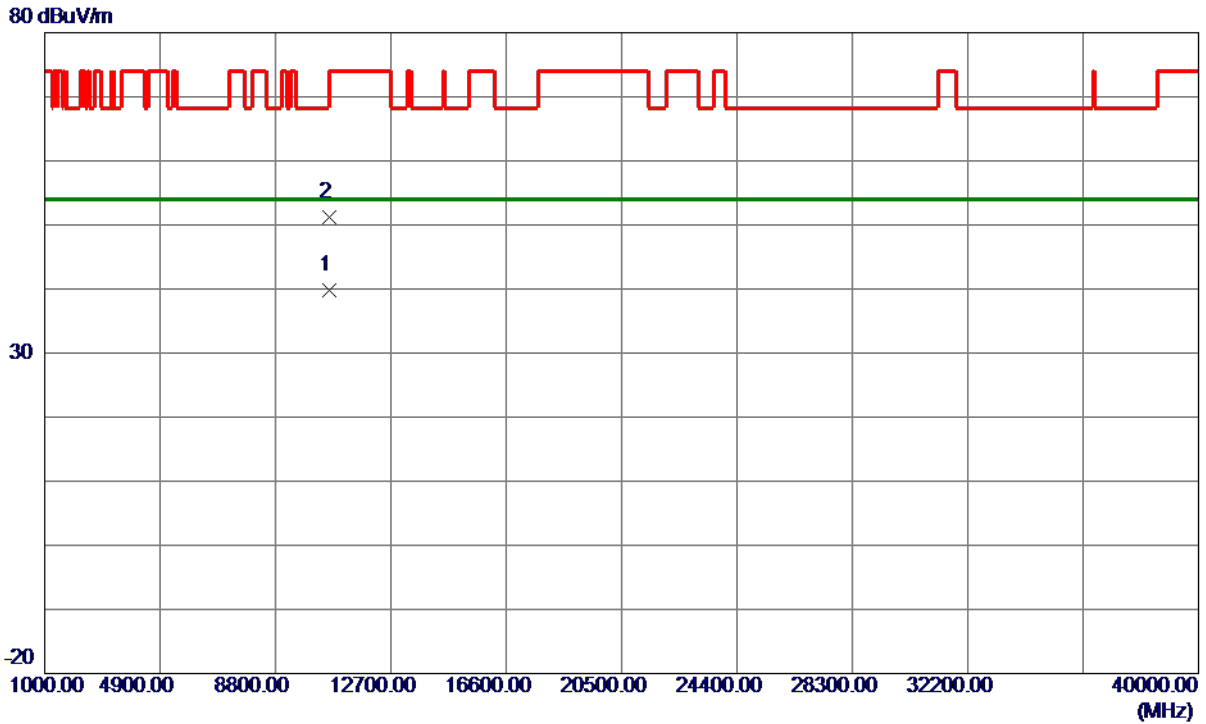

No.	Freq. MHz	Reading Level dBuV/m	Correct Factor dB	Measure ment dBuV/m	Limit dBuV/m	Margin dB	Detector	Comment
1 *	10631.0599	27.37	12.48	39.85	54.00	-14.15	AVG	
2	10631.4000	38.79	12.48	51.27	74.00	-22.73	Peak	

REMARKS:

- (1) Measurement Value = Reading Level + Correct Factor.
- (2) Margin Level = Measurement Value - Limit Value.

Orthogonal Axis	X
Test Mode	UNII-2A_TX AC (VHT20) Mode 5320 MHz

Horizontal

130 dBuV/m

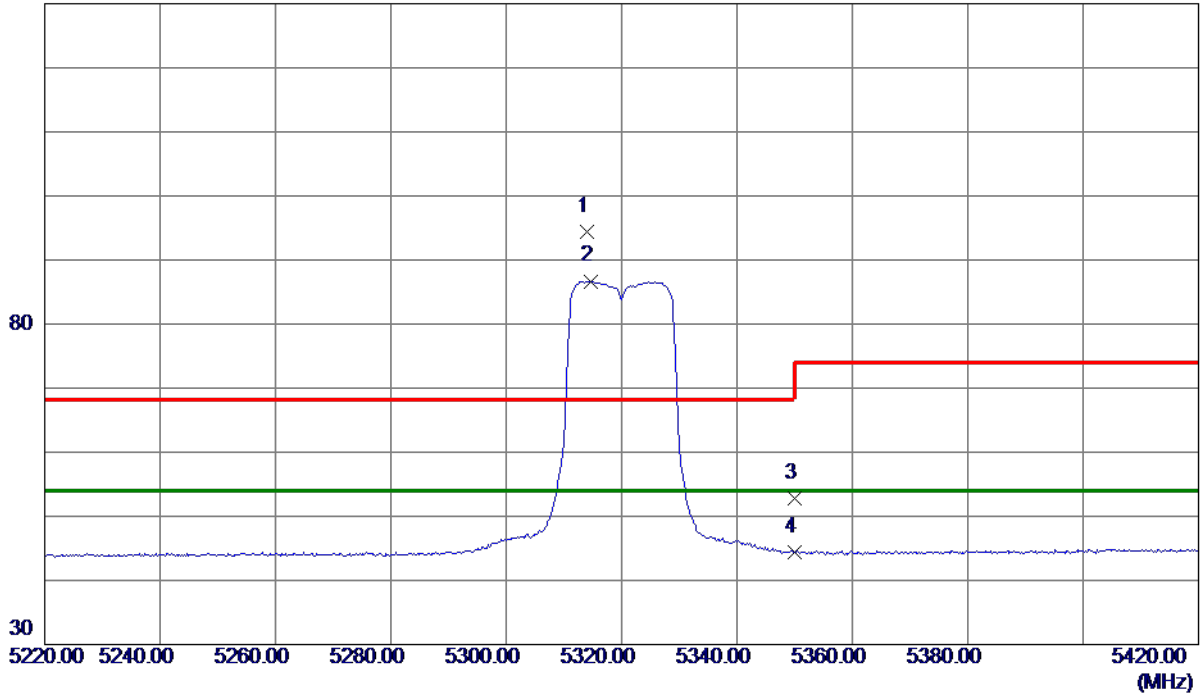

No.	Freq. MHz	Reading Level dBuV/m	Correct Factor dB	Measure ment dBuV/m	Limit dBuV/m	Margin dB	Detector	Comment
1	5314.0000	78.72	15.64	94.36	68.30	26.06	Peak	No Limit
2 *	5314.6000	71.06	15.64	86.70	54.00	32.70	AVG	No Limit
3	5350.0000	37.13	15.72	52.85	74.00	-21.15	Peak	
4	5350.0000	28.59	15.72	44.31	54.00	-9.69	AVG	

REMARKS:

- (1) Measurement Value = Reading Level + Correct Factor.
- (2) Margin Level = Measurement Value - Limit Value.

Orthogonal Axis	X
Test Mode	UNII-2A_TX AC (VHT20) Mode 5320 MHz

Horizontal

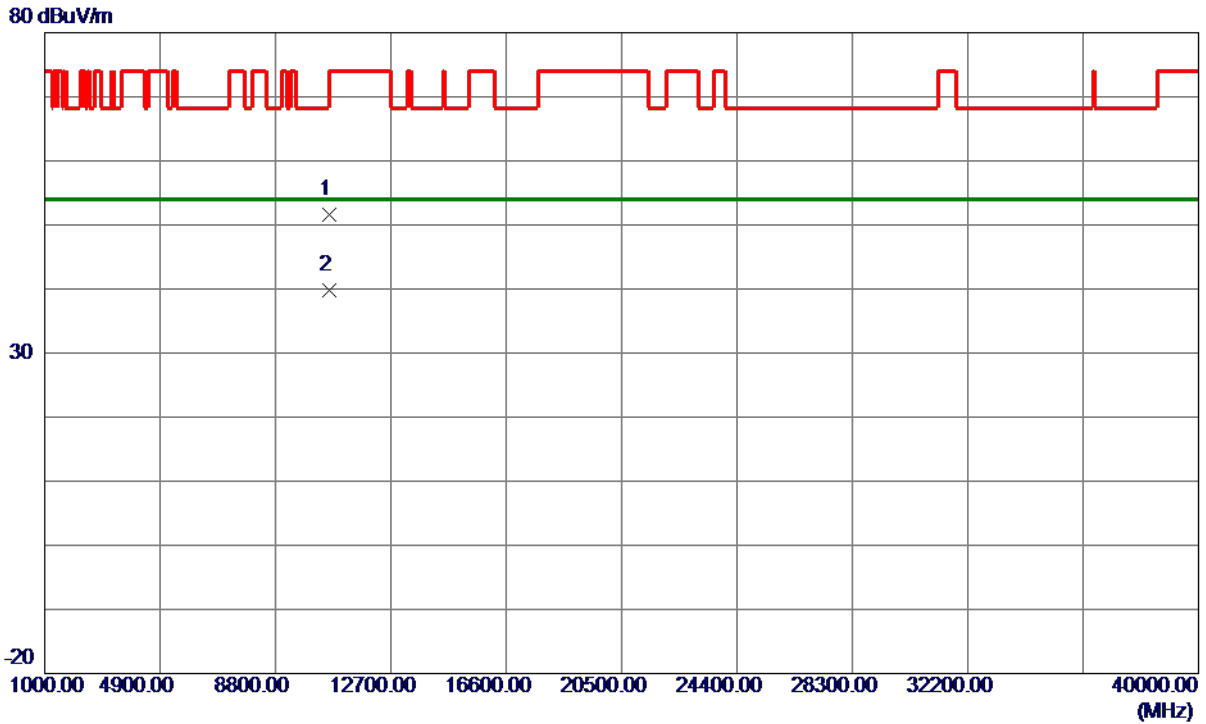

No.	Freq. MHz	Reading Level dBuV/m	Correct Factor dB	Measure ment dBuV/m	Limit dBuV/m	Margin dB	Detector	Comment
1	10641.5199	39.02	12.49	51.51	74.00	-22.49	Peak	
2 *	10641.6600	27.24	12.49	39.73	54.00	-14.27	AVG	

REMARKS:

- (1) Measurement Value = Reading Level + Correct Factor.
- (2) Margin Level = Measurement Value - Limit Value.

Orthogonal Axis	X
Test Mode	UNII-2A_TX AC (VHT40) Mode 5270 MHz

Vertical

130 dBuV/m

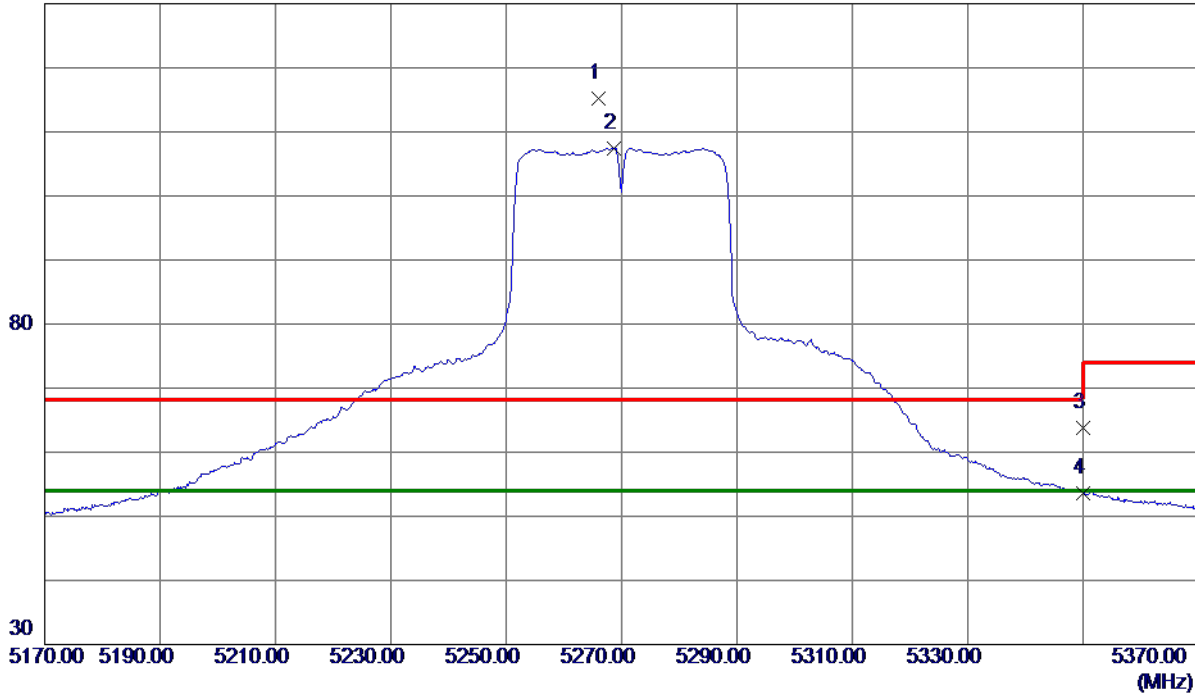

No.	Freq. MHz	Reading Level dBuV/m	Correct Factor dB	Measure ment dBuV/m	Limit dBuV/m	Margin dB	Detector	Comment
1	5265.9000	99.67	15.53	115.20	68.30	46.90	Peak	No Limit
2 *	5268.6000	91.92	15.54	107.46	54.00	53.46	AVG	No Limit
3	5350.0000	48.07	15.72	63.79	74.00	-10.21	Peak	
4	5350.0000	37.81	15.72	53.53	54.00	-0.47	AVG	

REMARKS:

- (1) Measurement Value = Reading Level + Correct Factor.
- (2) Margin Level = Measurement Value - Limit Value.

Orthogonal Axis	X
Test Mode	UNII-2A_TX AC (VHT40) Mode 5270 MHz

Vertical

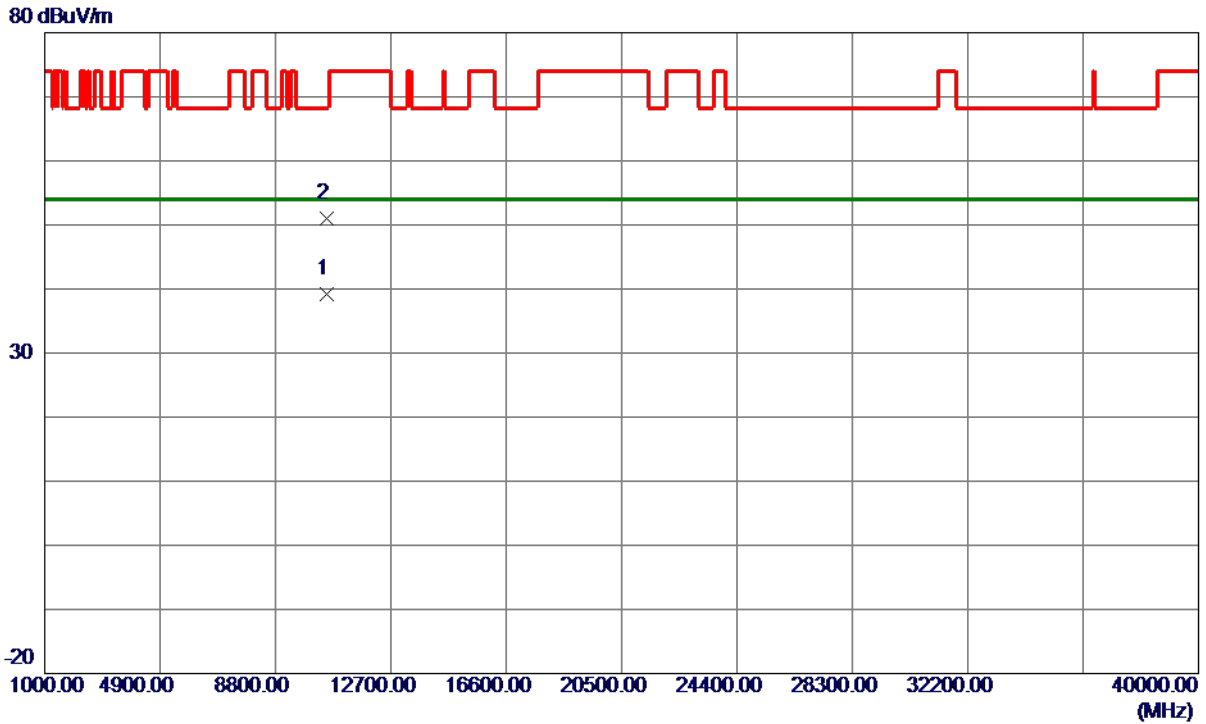

No.	Freq. MHz	Reading Level dBuV/m	Correct Factor dB	Measure ment dBuV/m	Limit dBuV/m	Margin dB	Detector	Comment
1 *	10541.6750	26.86	12.41	39.27	54.00	-14.73	AVG	
2	10541.8200	38.64	12.41	51.05	68.30	-17.25	Peak	

REMARKS:

- (1) Measurement Value = Reading Level + Correct Factor.
- (2) Margin Level = Measurement Value - Limit Value.

Orthogonal Axis	X
Test Mode	UNII-2A_TX AC (VHT40) Mode 5270 MHz

Horizontal

130 dBuV/m

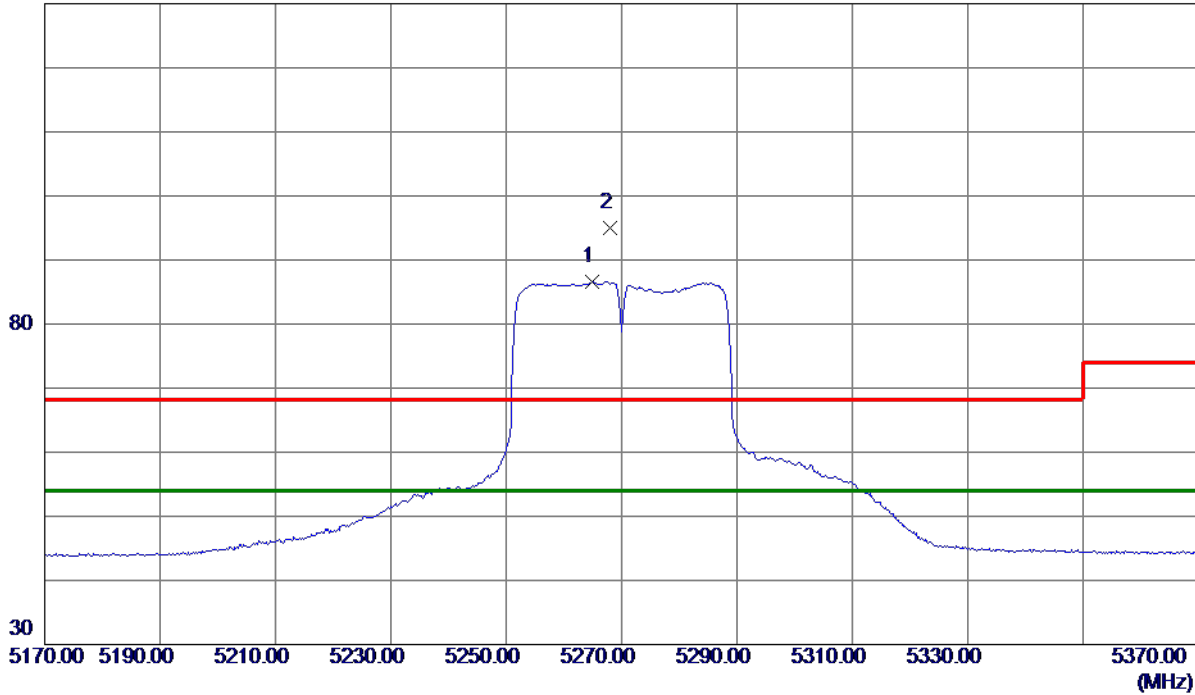

No.	Freq. MHz	Reading Level dBuV/m	Correct Factor dB	Measure ment dBuV/m	Limit dBuV/m	Margin dB	Detector	Comment
1 *	5264.8000	71.04	15.53	86.57	54.00	32.57	AVG	No Limit
2	5268.0000	79.55	15.53	95.08	68.30	26.78	Peak	No Limit

REMARKS:

- (1) Measurement Value = Reading Level + Correct Factor.
- (2) Margin Level = Measurement Value - Limit Value.

Orthogonal Axis	X
Test Mode	UNII-2A_TX AC (VHT40) Mode 5270 MHz

Horizontal

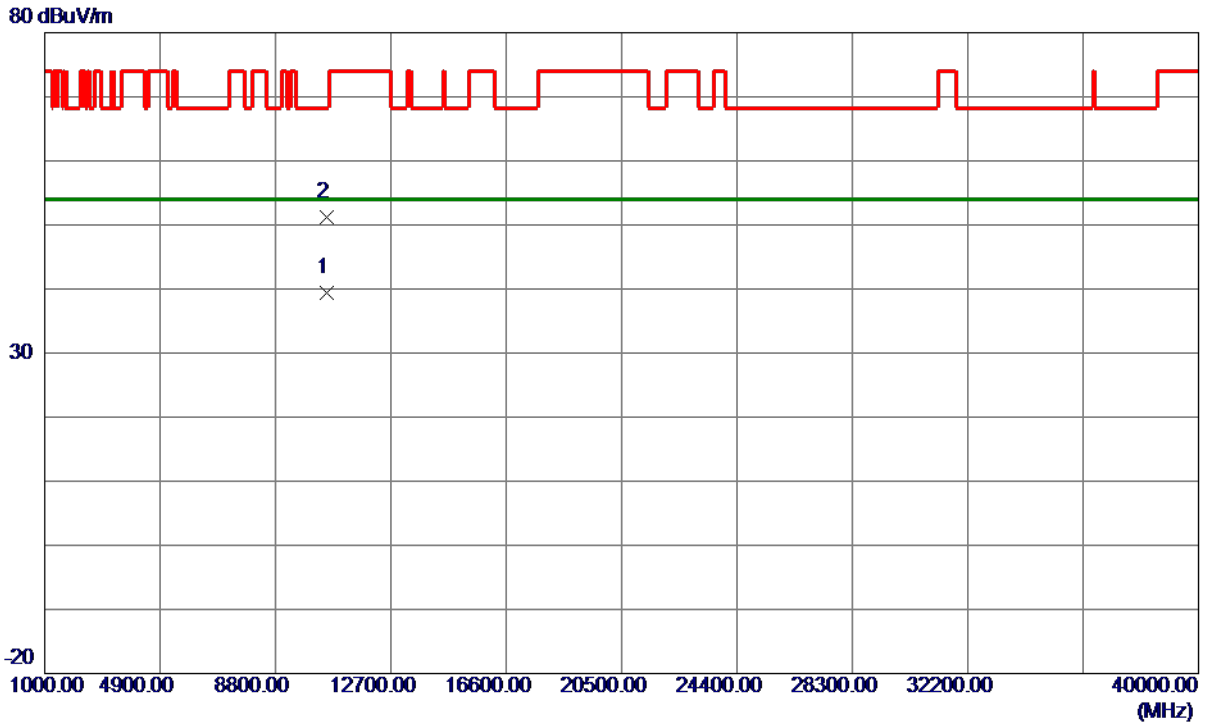

No.	Freq. MHz	Reading Level dBuV/m	Correct Factor dB	Measure ment dBuV/m	Limit dBuV/m	Margin dB	Detector	Comment
1 *	10538.0950	27.05	12.41	39.46	54.00	-14.54	AVG	
2	10539.9050	38.79	12.41	51.20	68.30	-17.10	Peak	

REMARKS:

- (1) Measurement Value = Reading Level + Correct Factor.
- (2) Margin Level = Measurement Value - Limit Value.

Orthogonal Axis	X
Test Mode	UNII-2A_TX AC (VHT40) Mode 5310 MHz

Vertical

130 dBuV/m

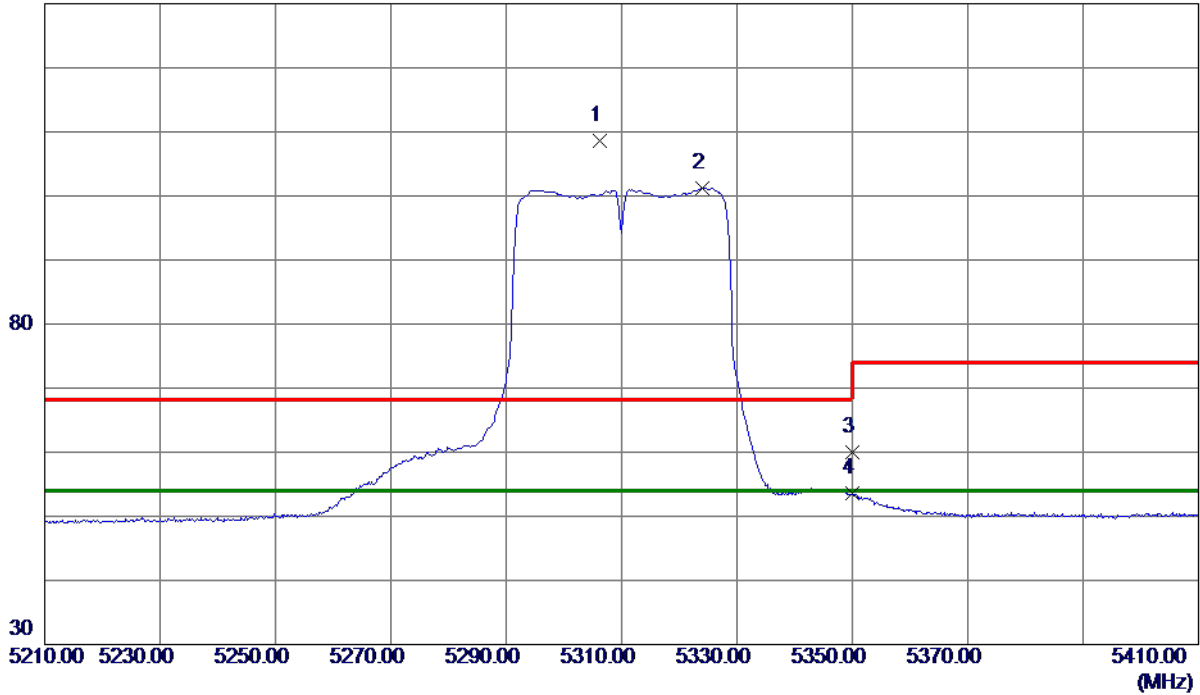

No.	Freq. MHz	Reading Level dBuV/m	Correct Factor dB	Measure ment dBuV/m	Limit dBuV/m	Margin dB	Detector	Comment
1	5306.2000	92.91	15.62	108.53	68.30	40.23	Peak	No Limit
2 *	5324.1000	85.51	15.66	101.17	54.00	47.17	AVG	No Limit
3	5350.0000	44.30	15.72	60.02	74.00	-13.98	Peak	
4	5350.0000	37.87	15.72	53.59	54.00	-0.41	AVG	

REMARKS:

- (1) Measurement Value = Reading Level + Correct Factor.
- (2) Margin Level = Measurement Value - Limit Value.

Orthogonal Axis	X
Test Mode	UNII-2A_TX AC (VHT40) Mode 5310 MHz

Vertical

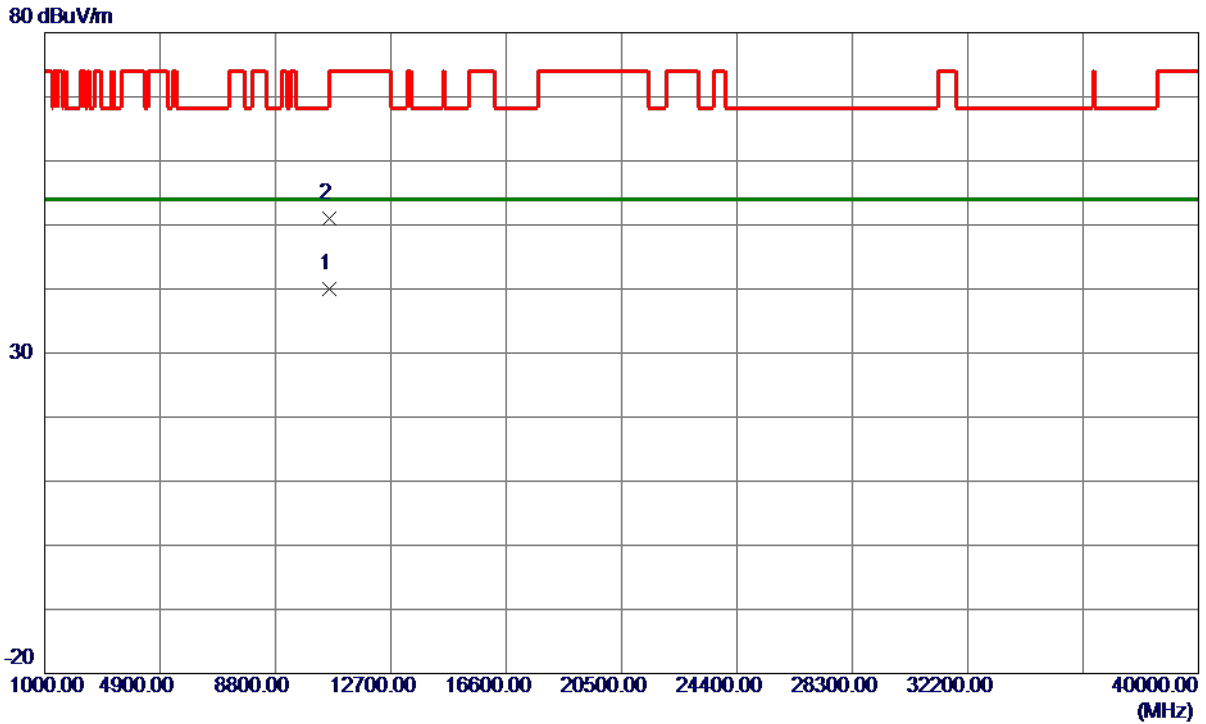

No.	Freq. MHz	Reading Level dBuV/m	Correct Factor dB	Measure ment dBuV/m	Limit dBuV/m	Margin dB	Detector	Comment
1 *	10618.8900	27.44	12.47	39.91	54.00	-14.09	AVG	
2	10619.5100	38.53	12.47	51.00	74.00	-23.00	Peak	

REMARKS:

- (1) Measurement Value = Reading Level + Correct Factor.
- (2) Margin Level = Measurement Value - Limit Value.

Orthogonal Axis	X
Test Mode	UNII-2A_TX AC (VHT40) Mode 5310 MHz

Horizontal

130 dBuV/m

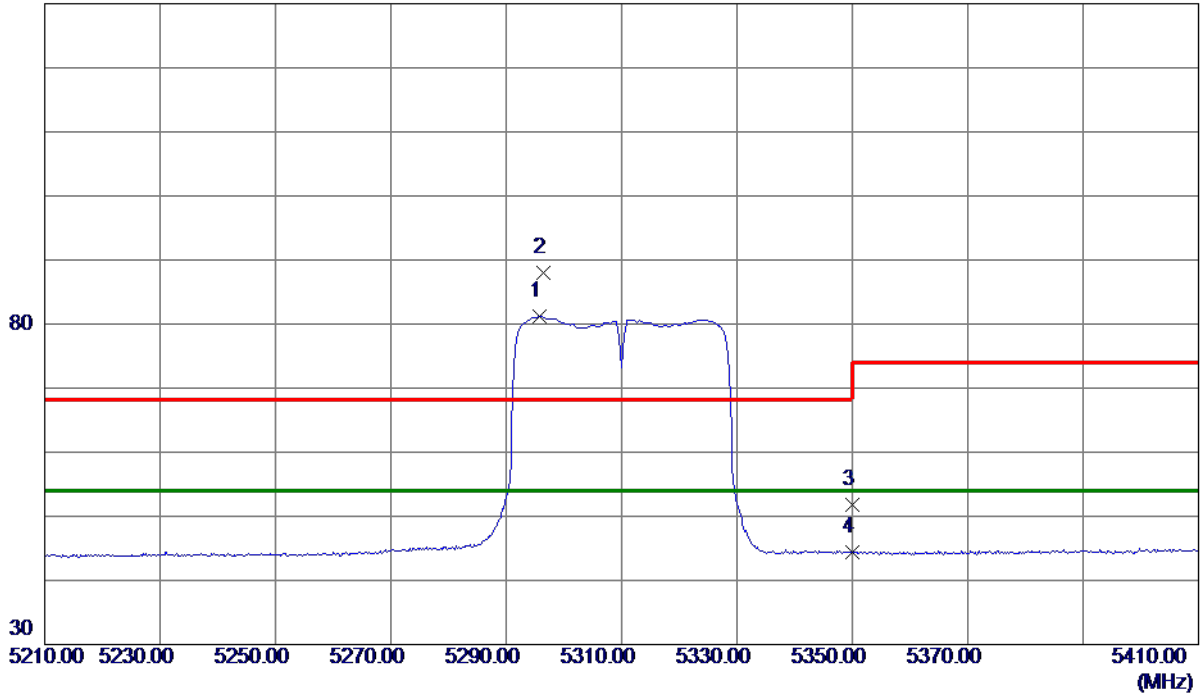

No.	Freq. MHz	Reading Level dBuV/m	Correct Factor dB	Measure ment dBuV/m	Limit dBuV/m	Margin dB	Detector	Comment
1 *	5295.8000	65.57	15.60	81.17	54.00	27.17	AVG	No Limit
2	5296.4000	72.46	15.60	88.06	68.30	19.76	Peak	No Limit
3	5350.0000	35.99	15.72	51.71	74.00	-22.29	Peak	
4	5350.0000	28.72	15.72	44.44	54.00	-9.56	AVG	

REMARKS:

- (1) Measurement Value = Reading Level + Correct Factor.
- (2) Margin Level = Measurement Value - Limit Value.

Orthogonal Axis	X
Test Mode	UNII-2A_TX AC (VHT40) Mode 5310 MHz

Horizontal

80 dBuV/m

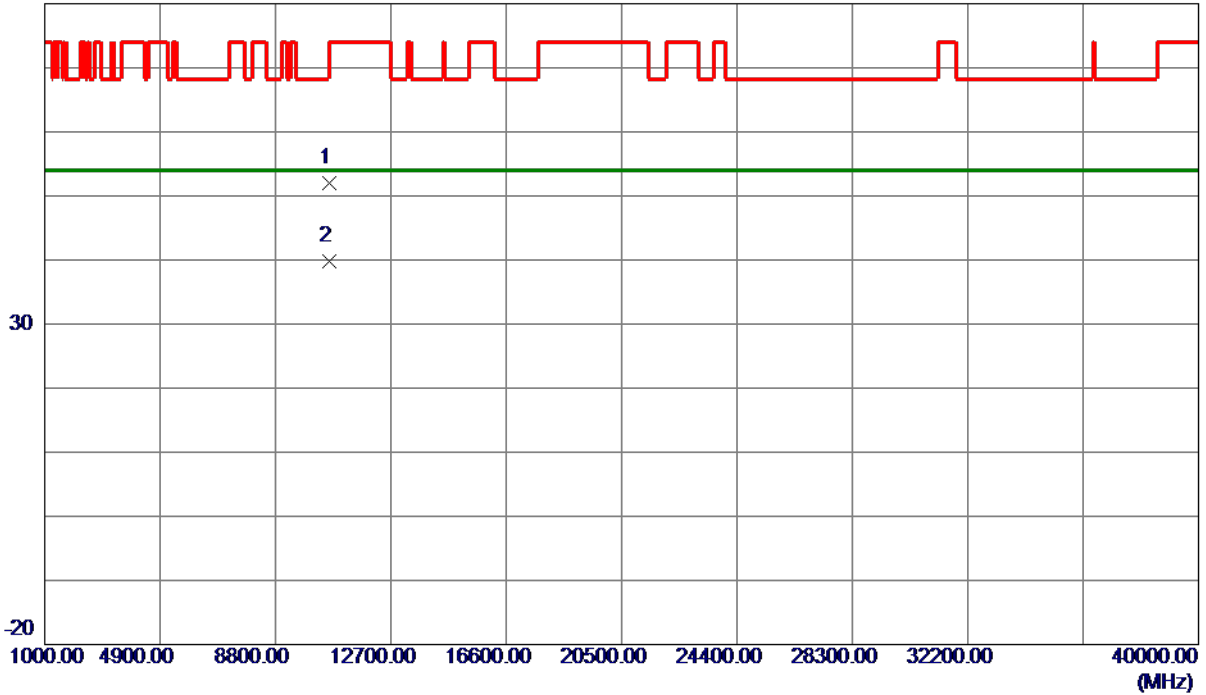

No.	Freq. MHz	Reading Level dBuV/m	Correct Factor dB	Measure ment dBuV/m	Limit dBuV/m	Margin dB	Detector	Comment
1	10620.9250	39.55	12.47	52.02	74.00	-21.98	Peak	
2 *	10622.0450	27.27	12.47	39.74	54.00	-14.26	AVG	

REMARKS:

- (1) Measurement Value = Reading Level + Correct Factor.
- (2) Margin Level = Measurement Value - Limit Value.

Orthogonal Axis	X
Test Mode	UNII-2A_TX AC (VHT80) Mode 5290 MHz

Vertical

130 dBuV/m

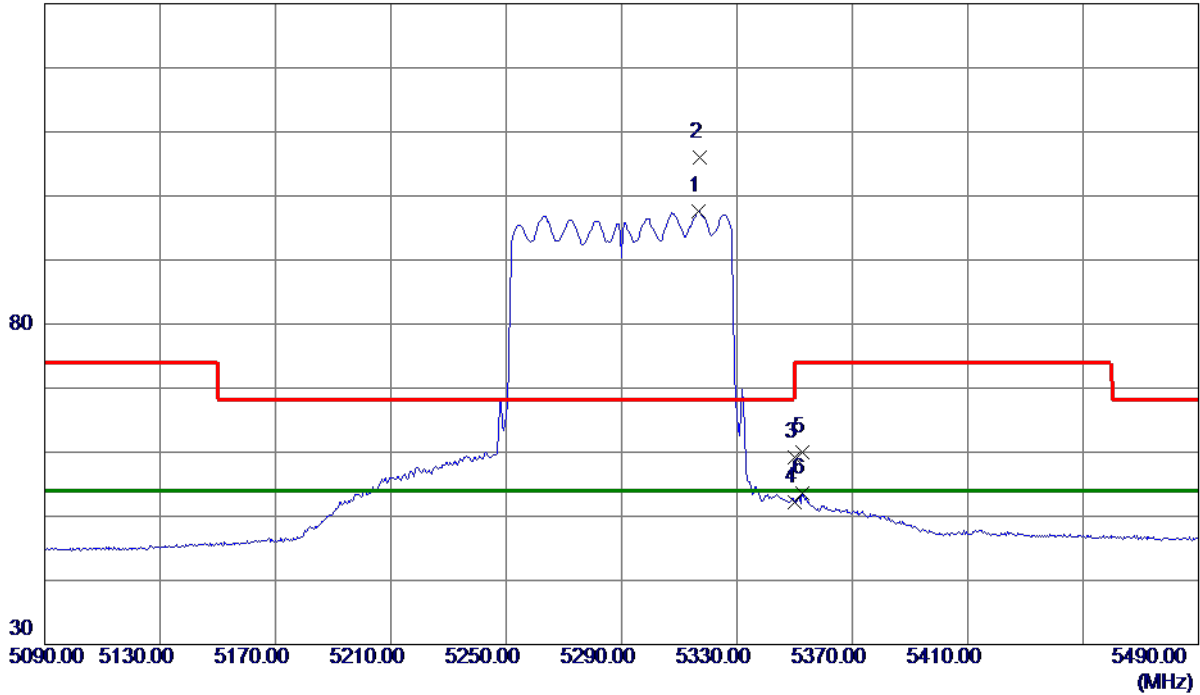

No.	Freq. MHz	Reading Level dBuV/m	Correct Factor dB	Measure ment dBuV/m	Limit dBuV/m	Margin dB	Detector	Comment
1 *	5316.8000	81.98	15.65	97.63	54.00	43.63	AVG	No Limit
2	5317.2000	90.36	15.65	106.01	68.30	37.71	Peak	No Limit
3	5350.0000	43.53	15.72	59.25	74.00	-14.75	Peak	
4	5350.0000	36.39	15.72	52.11	54.00	-1.89	AVG	
5	5352.8000	44.31	15.73	60.04	74.00	-13.96	Peak	
6	5352.8000	37.78	15.73	53.51	54.00	-0.49	AVG	

REMARKS:

- (1) Measurement Value = Reading Level + Correct Factor.
- (2) Margin Level = Measurement Value - Limit Value.

Orthogonal Axis	X
Test Mode	UNII-2A_TX AC (VHT80) Mode 5290 MHz

Vertical

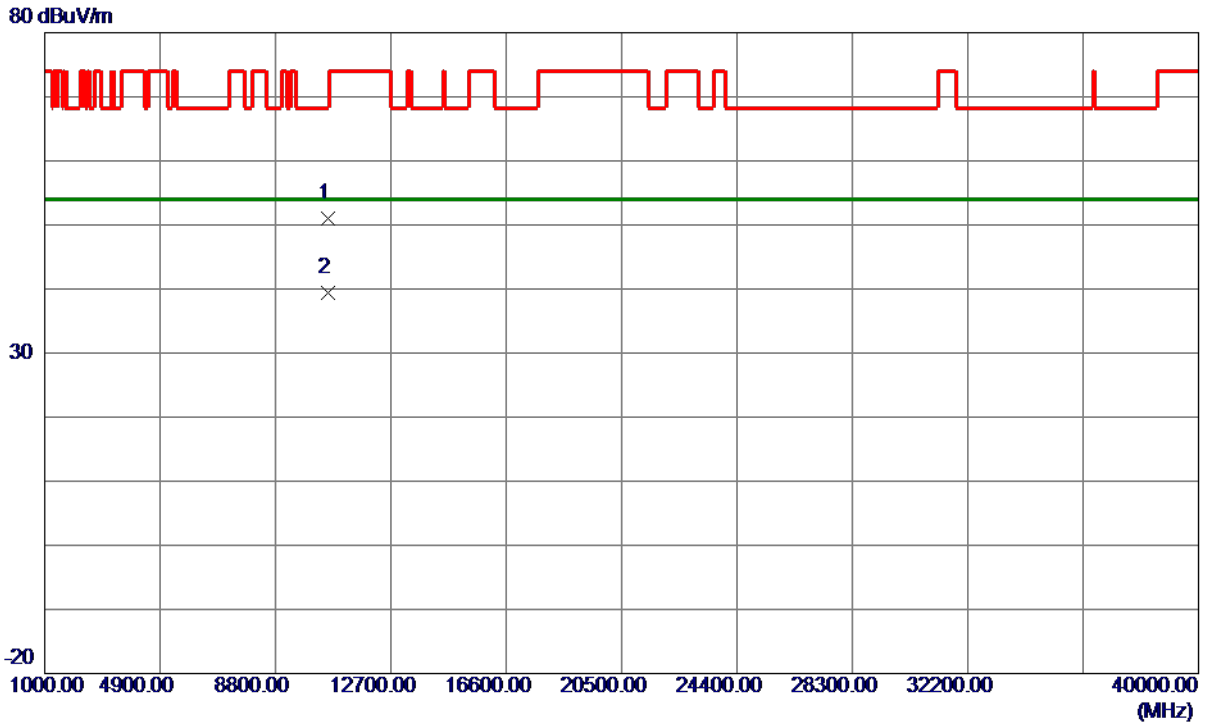

No.	Freq. MHz	Reading Level dBuV/m	Correct Factor dB	Measure ment dBuV/m	Limit dBuV/m	Margin dB	Detector	Comment
1	10581.5250	38.50	12.44	50.94	68.30	-17.36	Peak	
2 *	10581.6550	26.91	12.44	39.35	54.00	-14.65	AVG	

REMARKS:

- (1) Measurement Value = Reading Level + Correct Factor.
- (2) Margin Level = Measurement Value - Limit Value.

Orthogonal Axis	X
Test Mode	UNII-2A_TX AC (VHT80) Mode 5290 MHz

Horizontal

130 dBuV/m

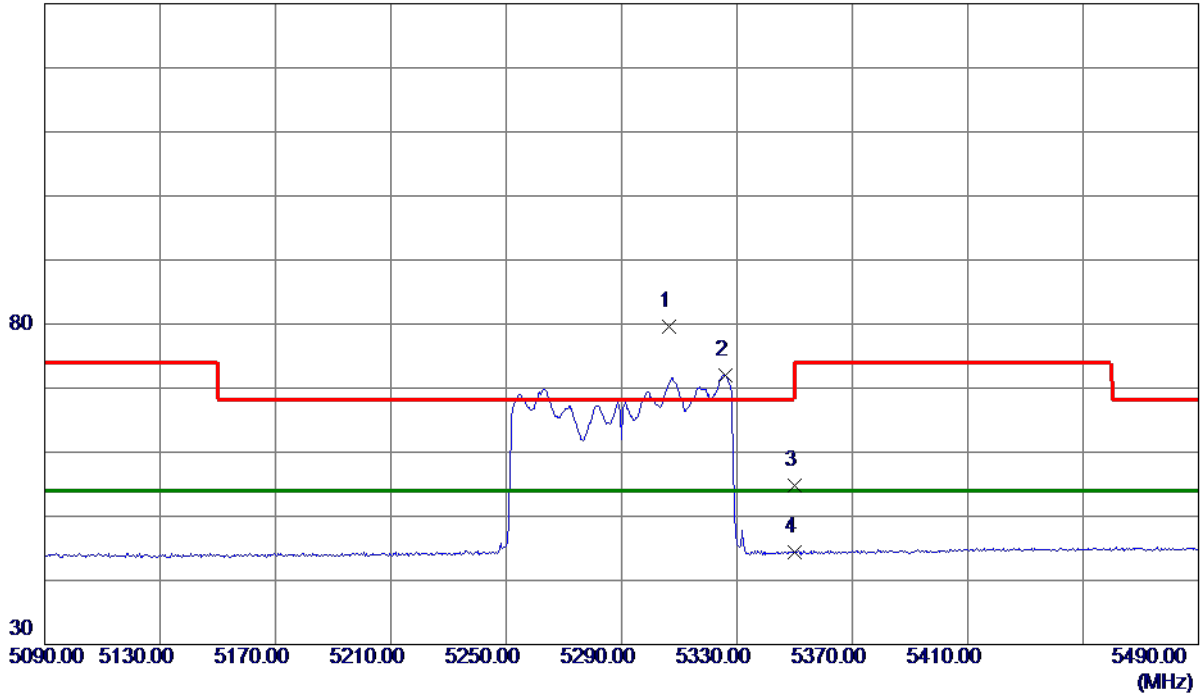

No.	Freq. MHz	Reading Level dBuV/m	Correct Factor dB	Measure ment dBuV/m	Limit dBuV/m	Margin dB	Detector	Comment
1	5306.4000	64.03	15.62	79.65	68.30	11.35	Peak	No Limit
2 *	5326.0000	56.38	15.67	72.05	54.00	18.05	AVG	No Limit
3	5350.0000	39.06	15.72	54.78	74.00	-19.22	Peak	
4	5350.0000	28.71	15.72	44.43	54.00	-9.57	AVG	

REMARKS:

- (1) Measurement Value = Reading Level + Correct Factor.
- (2) Margin Level = Measurement Value - Limit Value.

Orthogonal Axis	X
Test Mode	UNII-2A_TX AC (VHT80) Mode 5290 MHz

Horizontal

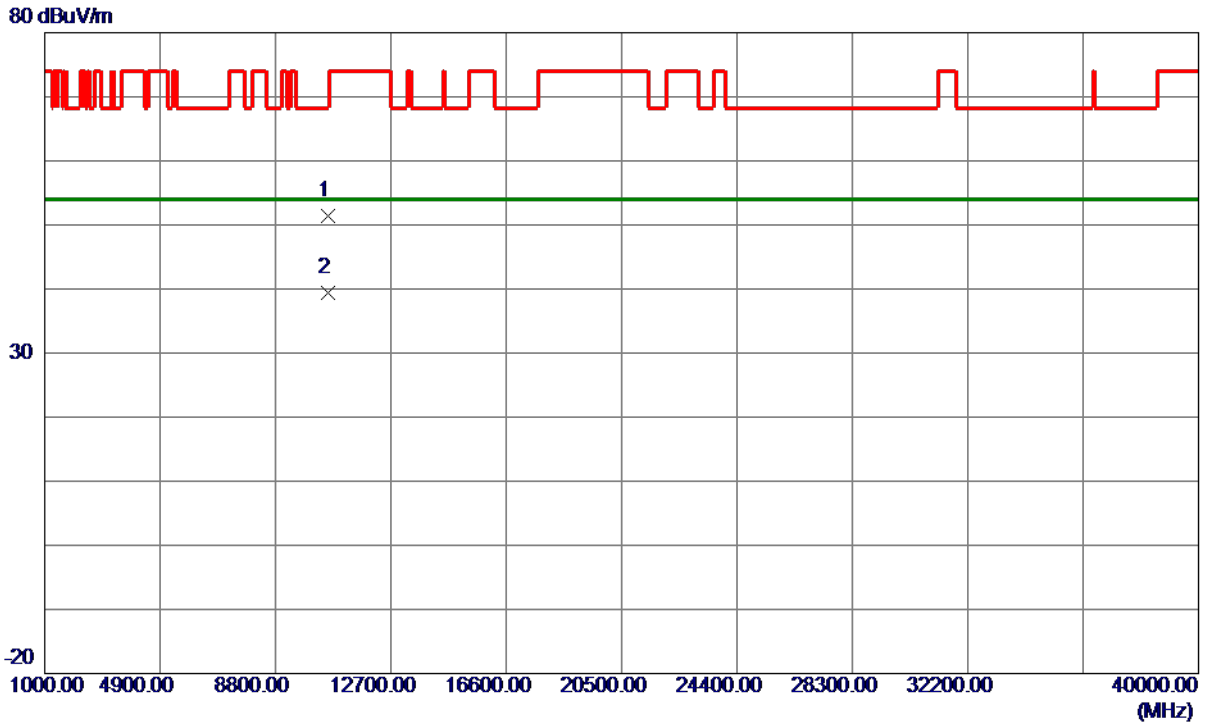

No.	Freq. MHz	Reading Level dBuV/m	Correct Factor dB	Measure ment dBuV/m	Limit dBuV/m	Margin dB	Detector	Comment
1	10578.5250	38.92	12.44	51.36	68.30	-16.94	Peak	
2 *	10581.7550	26.95	12.44	39.39	54.00	-14.61	AVG	

REMARKS:

- (1) Measurement Value = Reading Level + Correct Factor.
- (2) Margin Level = Measurement Value - Limit Value.

Orthogonal Axis	X
Test Mode	UNII-2C_TX AC (VHT20) Mode 5500 MHz

Vertical

130 dBuV/m

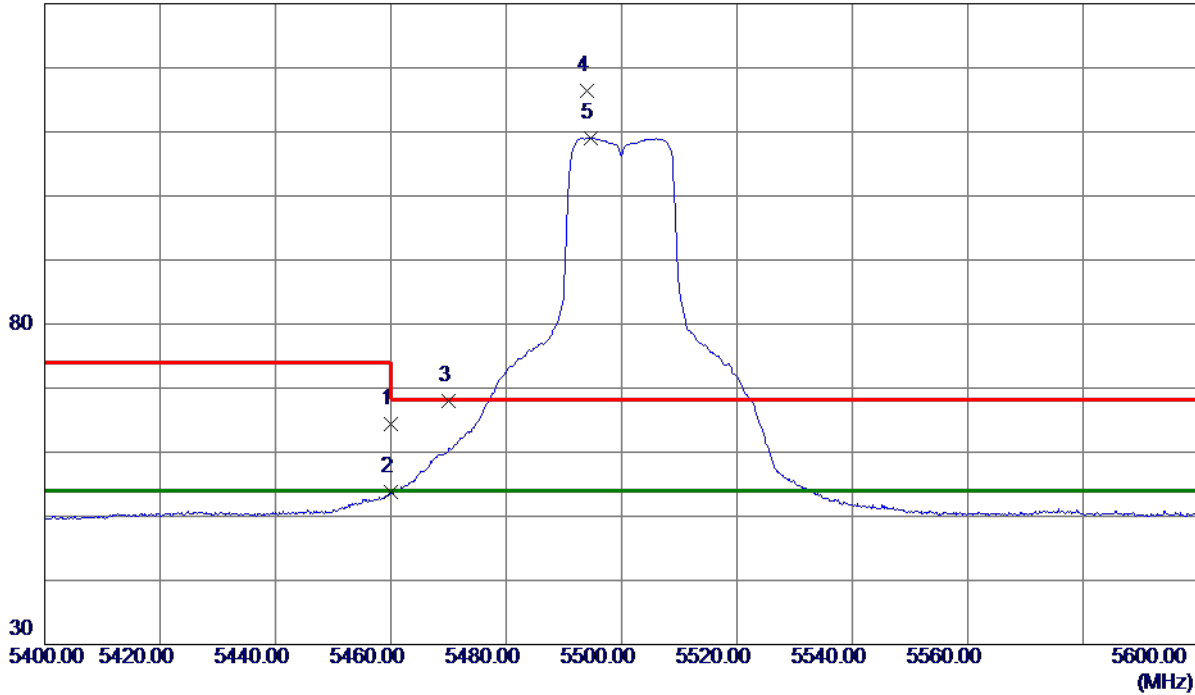

No.	Freq. MHz	Reading Level dBuV/m	Correct Factor dB	Measure ment dBuV/m	Limit dBuV/m	Margin dB	Detector	Comment
1	5460.0000	48.47	15.97	64.44	74.00	-9.56	Peak	
2	5460.0000	37.81	15.97	53.78	54.00	-0.22	AVG	
3	5470.0000	52.07	16.00	68.07	68.30	-0.23	Peak	
4	5494.1000	100.35	16.05	116.40	68.30	48.10	Peak	No Limit
5 *	5494.6000	92.96	16.05	109.01	54.00	55.01	AVG	No Limit

REMARKS:

- (1) Measurement Value = Reading Level + Correct Factor.
- (2) Margin Level = Measurement Value - Limit Value.

Orthogonal Axis	X
Test Mode	UNII-2C_TX AC (VHT20) Mode 5500 MHz

Vertical

80 dBuV/m

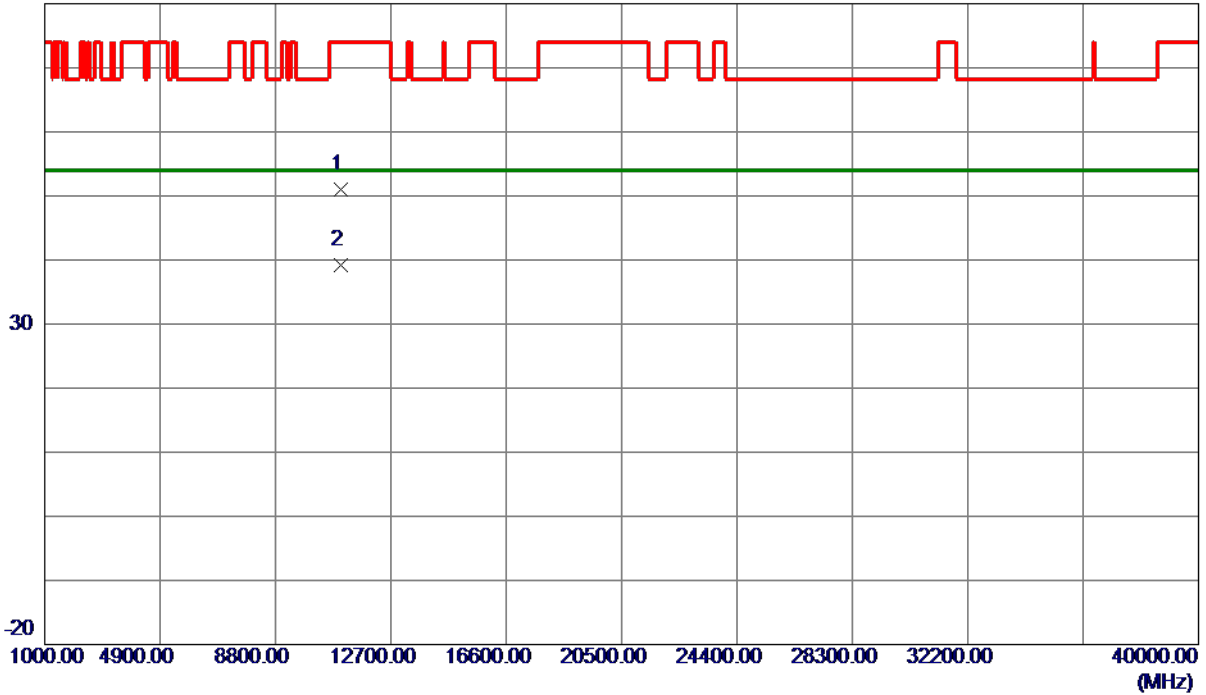

No.	Freq. MHz	Reading Level dBuV/m	Correct Factor dB	Measure ment dBuV/m	Limit dBuV/m	Margin dB	Detector	Comment
1	10994.2800	38.14	12.78	50.92	74.00	-23.08	Peak	
2 *	11006.7000	26.47	12.78	39.25	54.00	-14.75	AVG	

REMARKS:

- (1) Measurement Value = Reading Level + Correct Factor.
- (2) Margin Level = Measurement Value - Limit Value.

Orthogonal Axis	X
Test Mode	UNII-2C_TX AC (VHT20) Mode 5500 MHz

Horizontal

130 dBuV/m

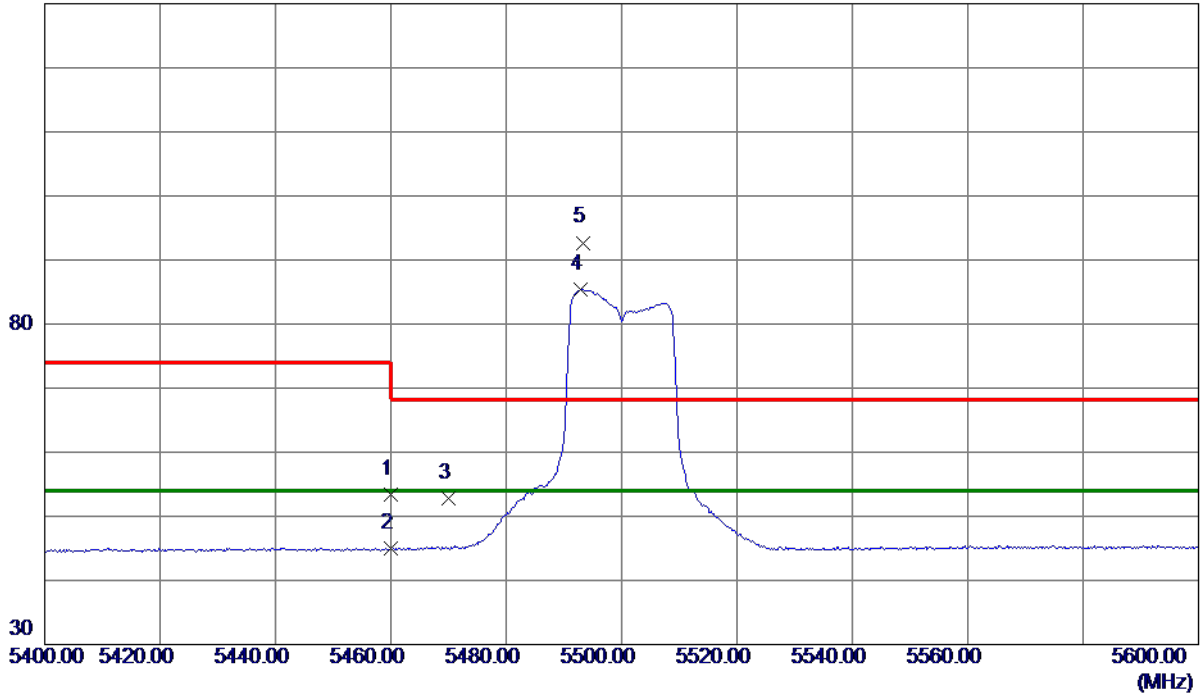

No.	Freq. MHz	Reading Level dBuV/m	Correct Factor dB	Measure ment dBuV/m	Limit dBuV/m	Margin dB	Detector	Comment
1	5460.0000	37.37	15.97	53.34	74.00	-20.66	Peak	
2	5460.0000	28.95	15.97	44.92	54.00	-9.08	AVG	
3	5470.0000	36.72	16.00	52.72	68.30	-15.58	Peak	
4 *	5492.8000	69.43	16.05	85.48	54.00	31.48	AVG	No Limit
5	5493.4000	76.65	16.05	92.70	68.30	24.40	Peak	No Limit

REMARKS:

- (1) Measurement Value = Reading Level + Correct Factor.
- (2) Margin Level = Measurement Value - Limit Value.

Orthogonal Axis	X
Test Mode	UNII-2C_TX AC (VHT20) Mode 5500 MHz

Horizontal

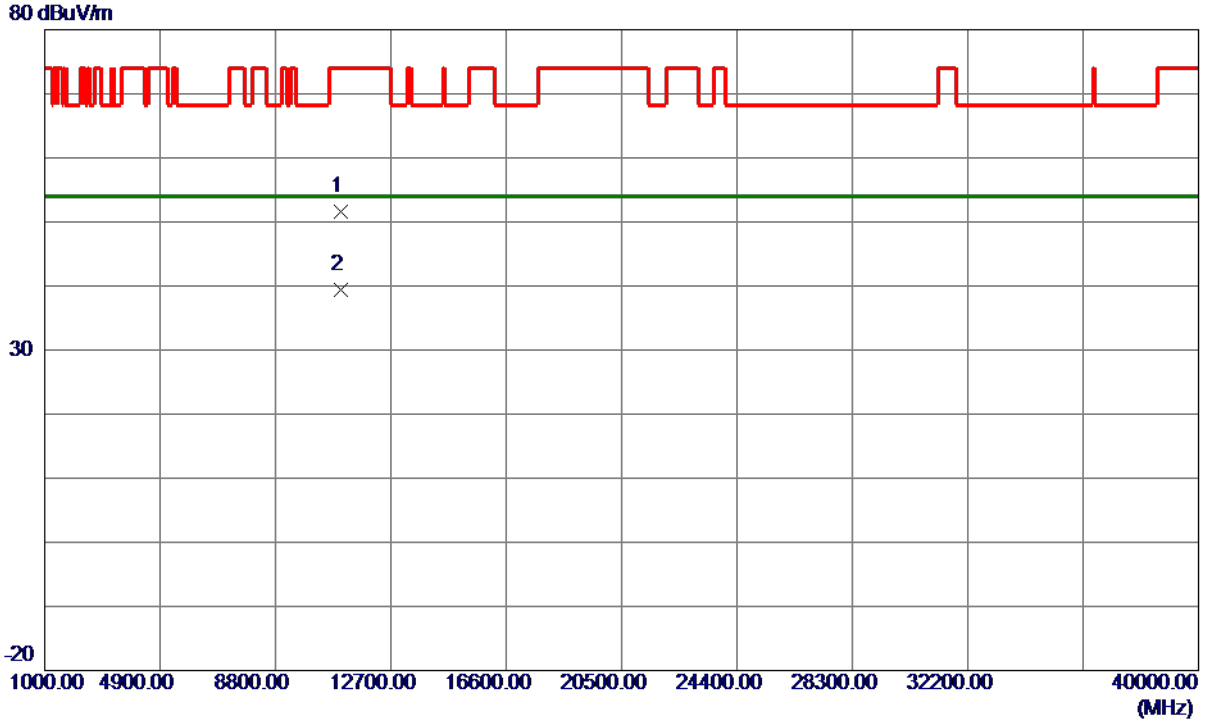

No.	Freq. MHz	Reading Level dBuV/m	Correct Factor dB	Measure ment dBuV/m	Limit dBuV/m	Margin dB	Detector	Comment
1	10993.3600	38.81	12.77	51.58	74.00	-22.42	Peak	
2 *	11002.2400	26.54	12.78	39.32	54.00	-14.68	AVG	

REMARKS:

- (1) Measurement Value = Reading Level + Correct Factor.
- (2) Margin Level = Measurement Value - Limit Value.

Orthogonal Axis	X
Test Mode	UNII-2C_TX AC (VHT20) Mode 5580 MHz

Vertical

130 dBuV/m

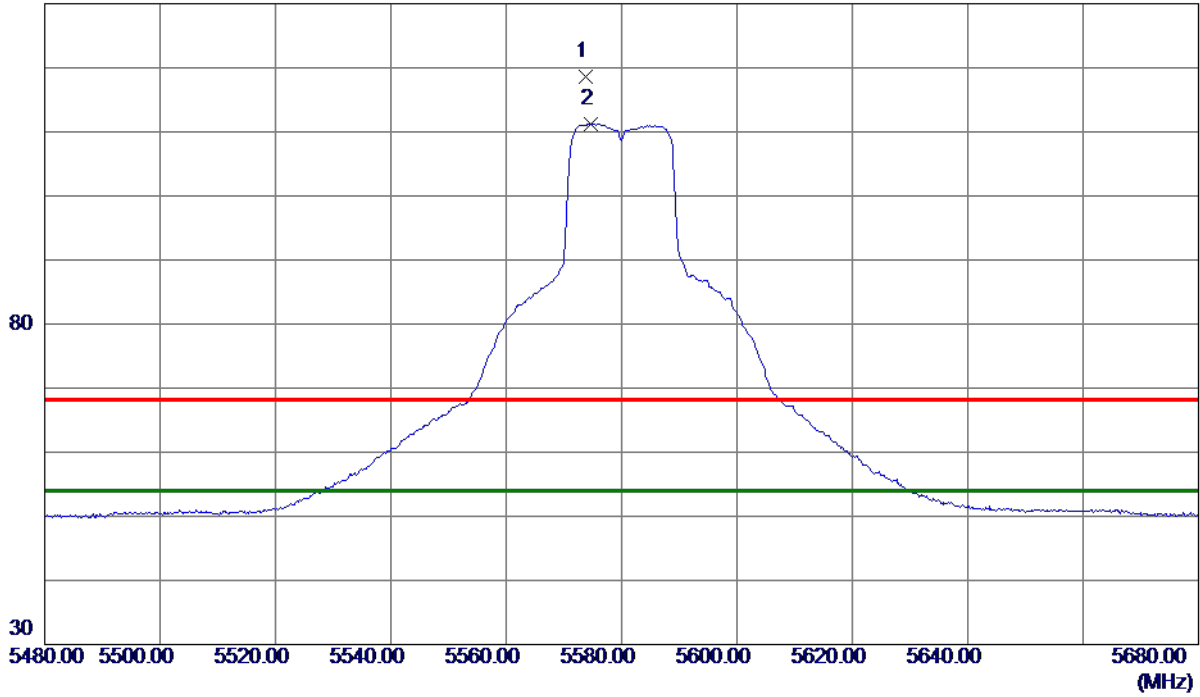

No.	Freq. MHz	Reading Level dBuV/m	Correct Factor dB	Measure ment dBuV/m	Limit dBuV/m	Margin dB	Detector	Comment
1	5573.8000	102.36	16.21	118.57	68.30	50.27	Peak	No Limit
2 *	5574.7000	95.05	16.21	111.26	54.00	57.26	AVG	No Limit

REMARKS:

- (1) Measurement Value = Reading Level + Correct Factor.
- (2) Margin Level = Measurement Value - Limit Value.

Orthogonal Axis	X
Test Mode	UNII-2C_TX AC (VHT20) Mode 5580 MHz

Vertical

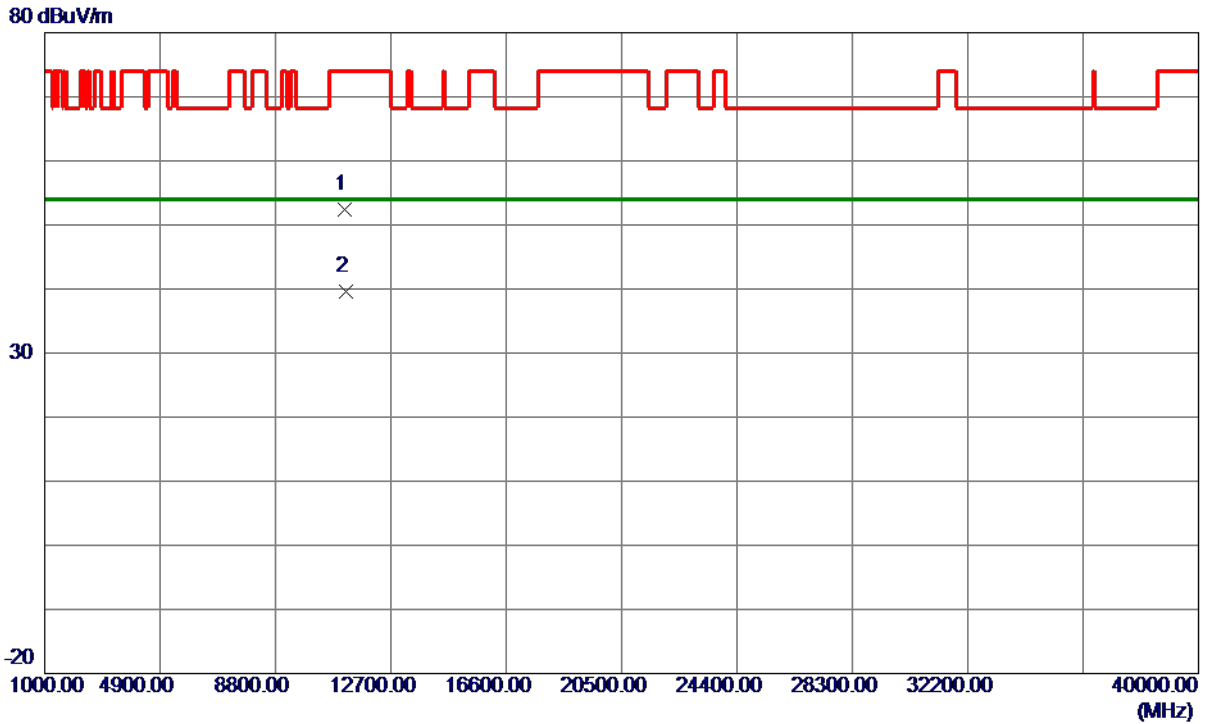

No.	Freq. MHz	Reading Level dBuV/m	Correct Factor dB	Measure ment dBuV/m	Limit dBuV/m	Margin dB	Detector	Comment
1	11158.4800	39.54	12.90	52.44	74.00	-21.56	Peak	
2 *	11166.6200	26.65	12.90	39.55	54.00	-14.45	AVG	

REMARKS:

- (1) Measurement Value = Reading Level + Correct Factor.
- (2) Margin Level = Measurement Value - Limit Value.

Orthogonal Axis	X
Test Mode	UNII-2C_TX AC (VHT20) Mode 5580 MHz

Horizontal

130 dBuV/m

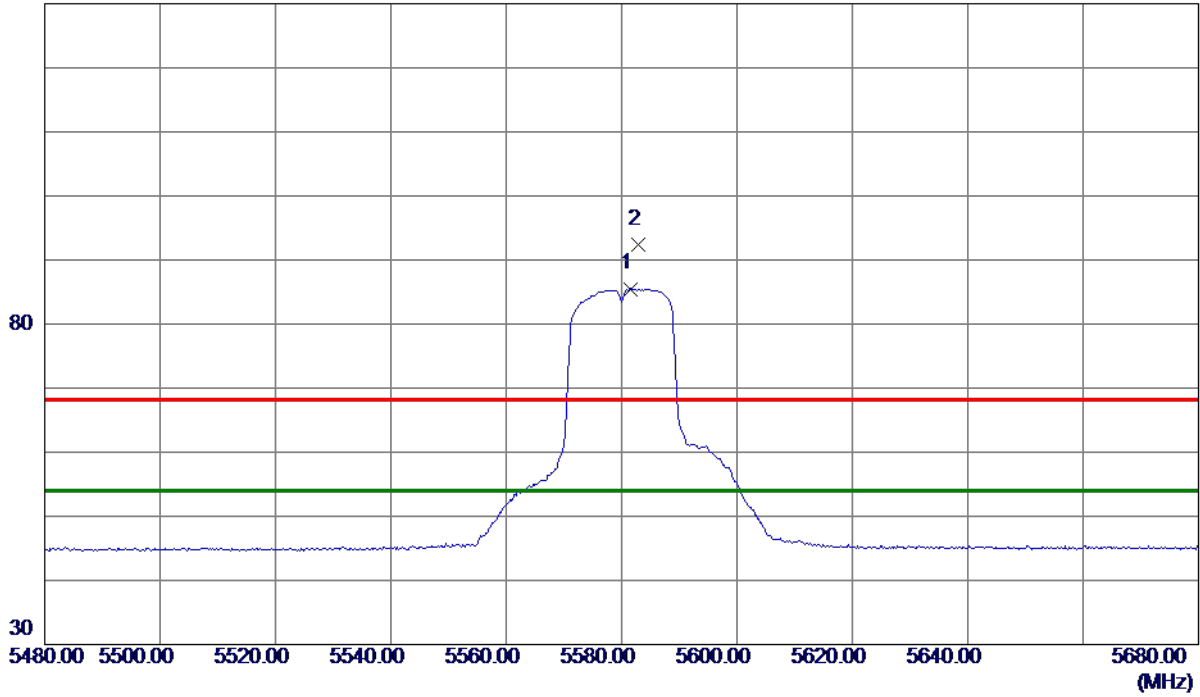

No.	Freq. MHz	Reading Level dBuV/m	Correct Factor dB	Measure ment dBuV/m	Limit dBuV/m	Margin dB	Detector	Comment
1 *	5581.6000	69.27	16.23	85.50	54.00	31.50	AVG	No Limit
2	5582.8000	76.20	16.23	92.43	68.30	24.13	Peak	No Limit

REMARKS:

- (1) Measurement Value = Reading Level + Correct Factor.
- (2) Margin Level = Measurement Value - Limit Value.

Orthogonal Axis	X
Test Mode	UNII-2C_TX AC (VHT20) Mode 5580 MHz

Horizontal

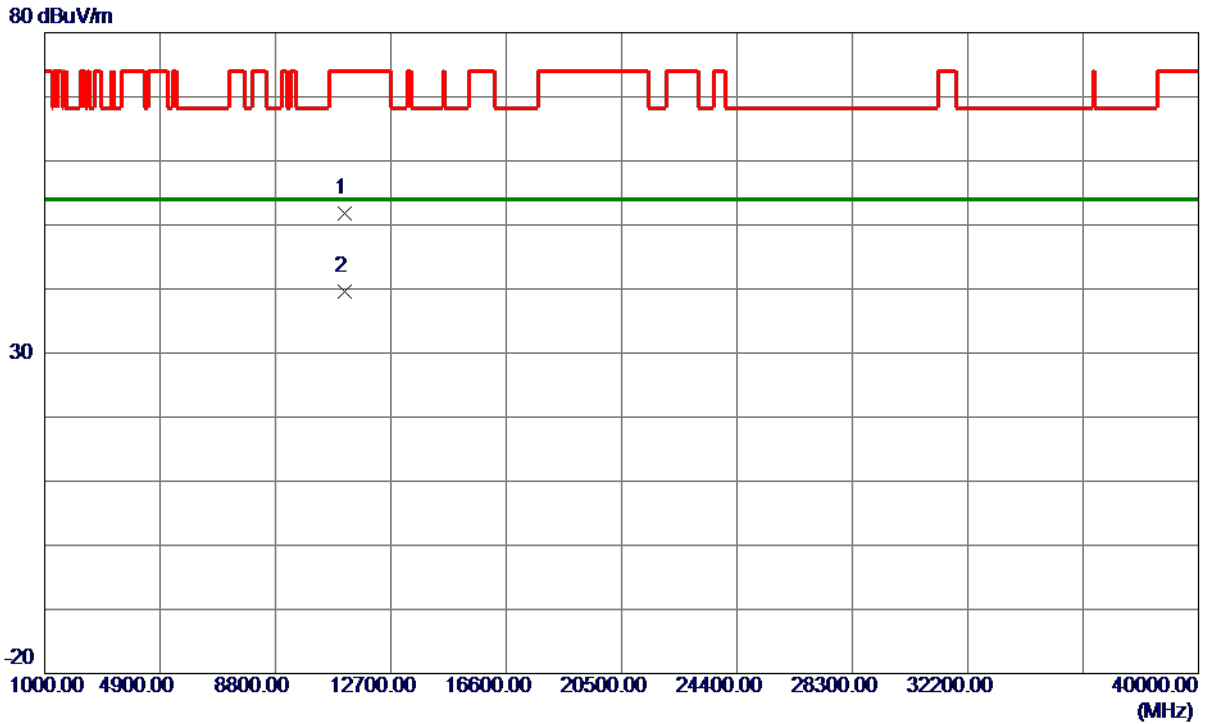

No.	Freq. MHz	Reading Level dBuV/m	Correct Factor dB	Measure ment dBuV/m	Limit dBuV/m	Margin dB	Detector	Comment
1	11156.5599	38.87	12.90	51.77	74.00	-22.23	Peak	
2 *	11160.3200	26.65	12.90	39.55	54.00	-14.45	AVG	

REMARKS:

- (1) Measurement Value = Reading Level + Correct Factor.
- (2) Margin Level = Measurement Value - Limit Value.

Orthogonal Axis	X
Test Mode	UNII-2C_TX AC (VHT20) Mode 5700 MHz

Vertical

130 dBuV/m

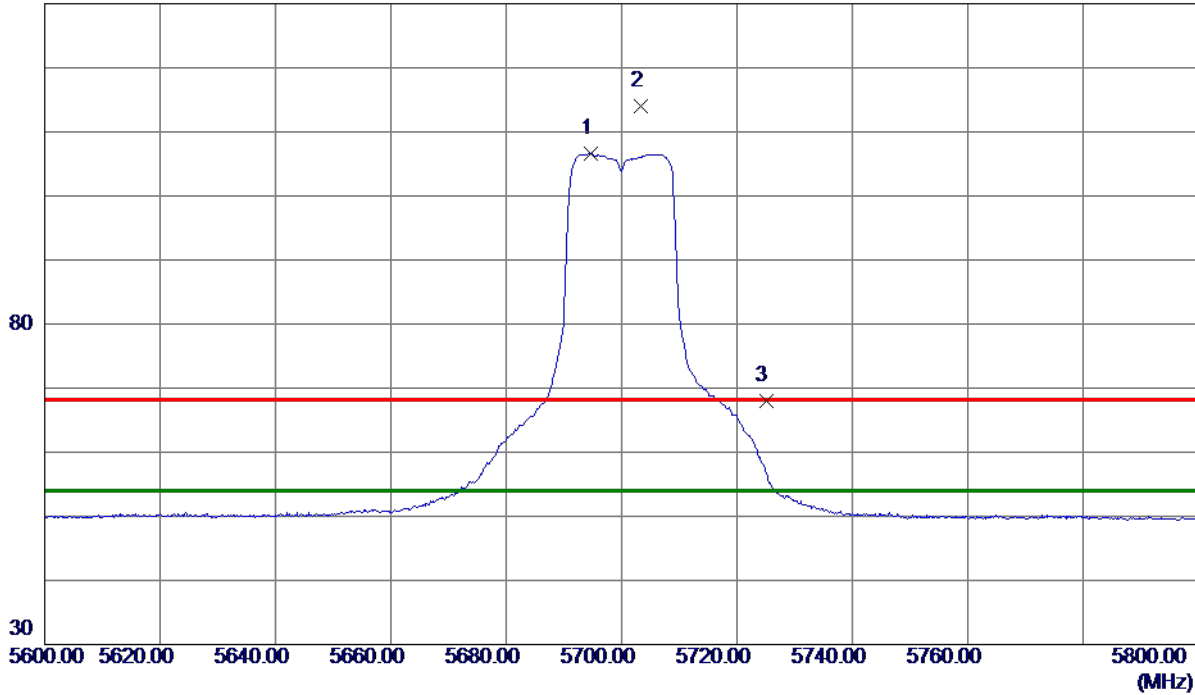

No.	Freq. MHz	Reading Level dBuV/m	Correct Factor dB	Measure ment dBuV/m	Limit dBuV/m	Margin dB	Detector	Comment
1 *	5694.6000	90.11	16.45	106.56	54.00	52.56	AVG	No Limit
2	5703.3000	97.45	16.47	113.92	68.30	45.62	Peak	No Limit
3	5725.0000	51.53	16.51	68.04	68.30	-0.26	Peak	

REMARKS:

- (1) Measurement Value = Reading Level + Correct Factor.
- (2) Margin Level = Measurement Value - Limit Value.

Orthogonal Axis	X
Test Mode	UNII-2C_TX AC (VHT20) Mode 5700 MHz

Vertical

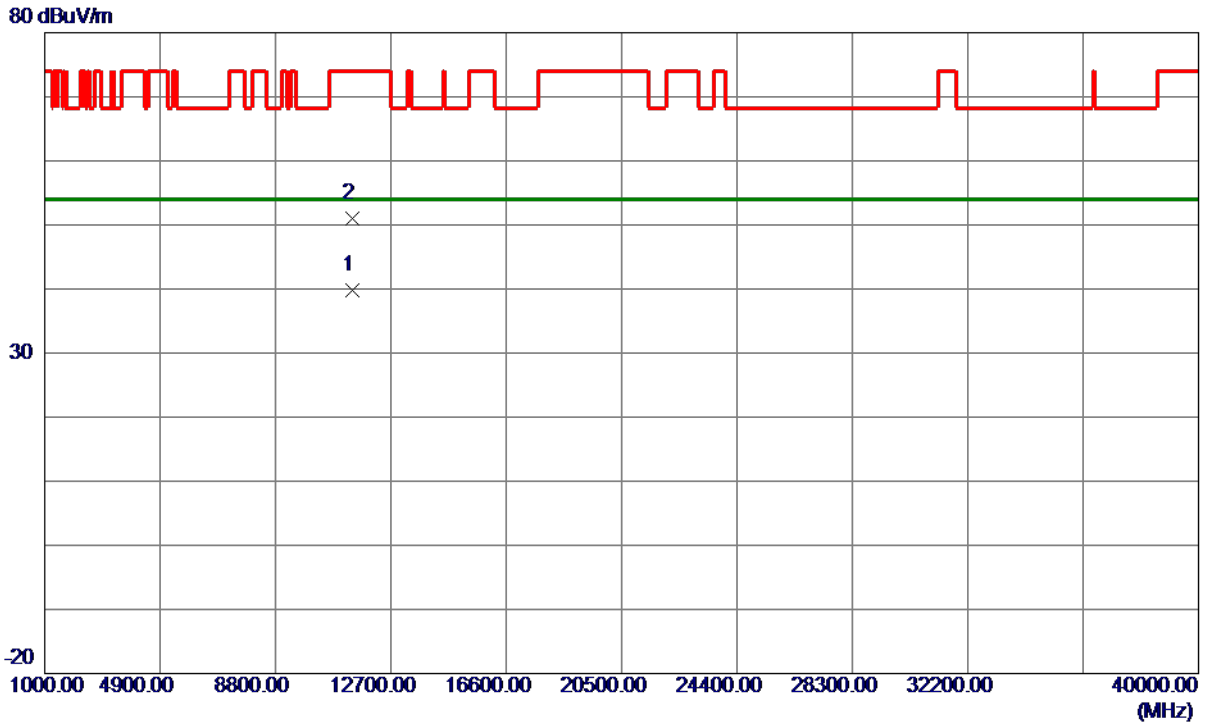

No.	Freq. MHz	Reading Level dBuV/m	Correct Factor dB	Measure ment dBuV/m	Limit dBuV/m	Margin dB	Detector	Comment
1 *	11409.6000	26.76	13.09	39.85	54.00	-14.15	AVG	
2	11400.0599	37.98	13.08	51.06	74.00	-22.94	Peak	

REMARKS:

- (1) Measurement Value = Reading Level + Correct Factor.
- (2) Margin Level = Measurement Value - Limit Value.

Orthogonal Axis	X
Test Mode	UNII-2C_TX AC (VHT20) Mode 5700 MHz

Horizontal

130 dBuV/m

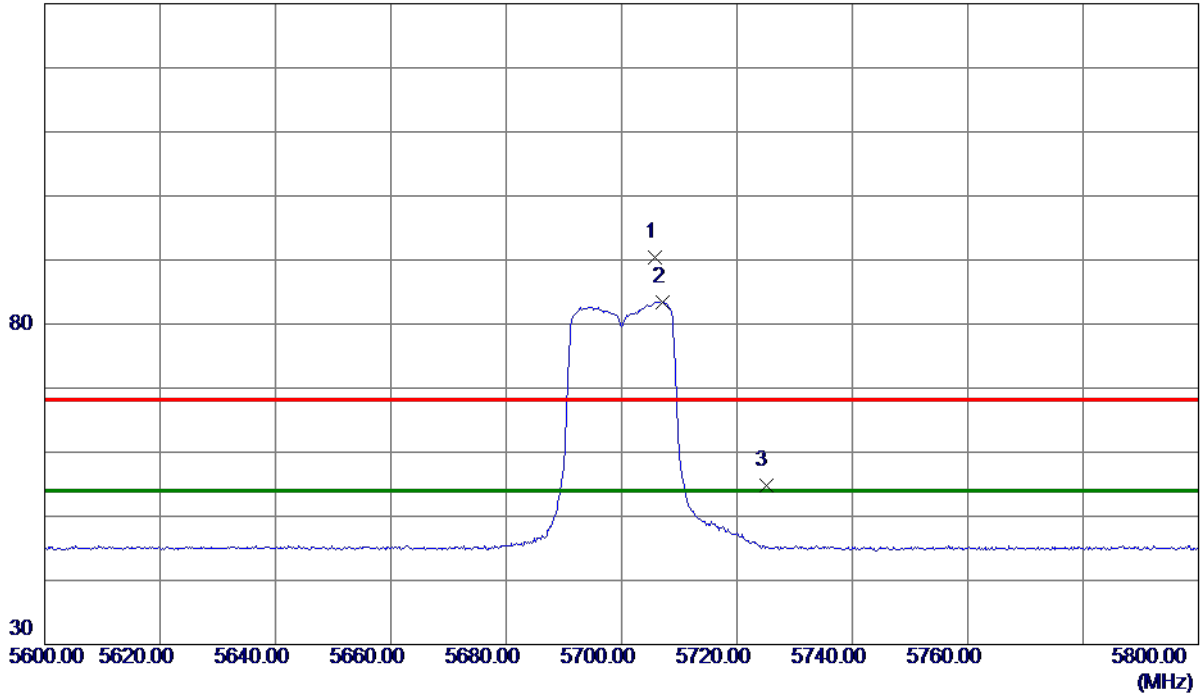

No.	Freq. MHz	Reading Level dBuV/m	Correct Factor dB	Measure ment dBuV/m	Limit dBuV/m	Margin dB	Detector	Comment
1	5705.8000	73.92	16.47	90.39	68.30	22.09	Peak	No Limit
2 *	5707.2000	67.00	16.48	83.48	54.00	29.48	AVG	No Limit
3	5725.0000	38.34	16.51	54.85	68.30	-13.45	Peak	

REMARKS:

- (1) Measurement Value = Reading Level + Correct Factor.
- (2) Margin Level = Measurement Value - Limit Value.

Orthogonal Axis	X
Test Mode	UNII-2C_TX AC (VHT20) Mode 5700 MHz

Horizontal

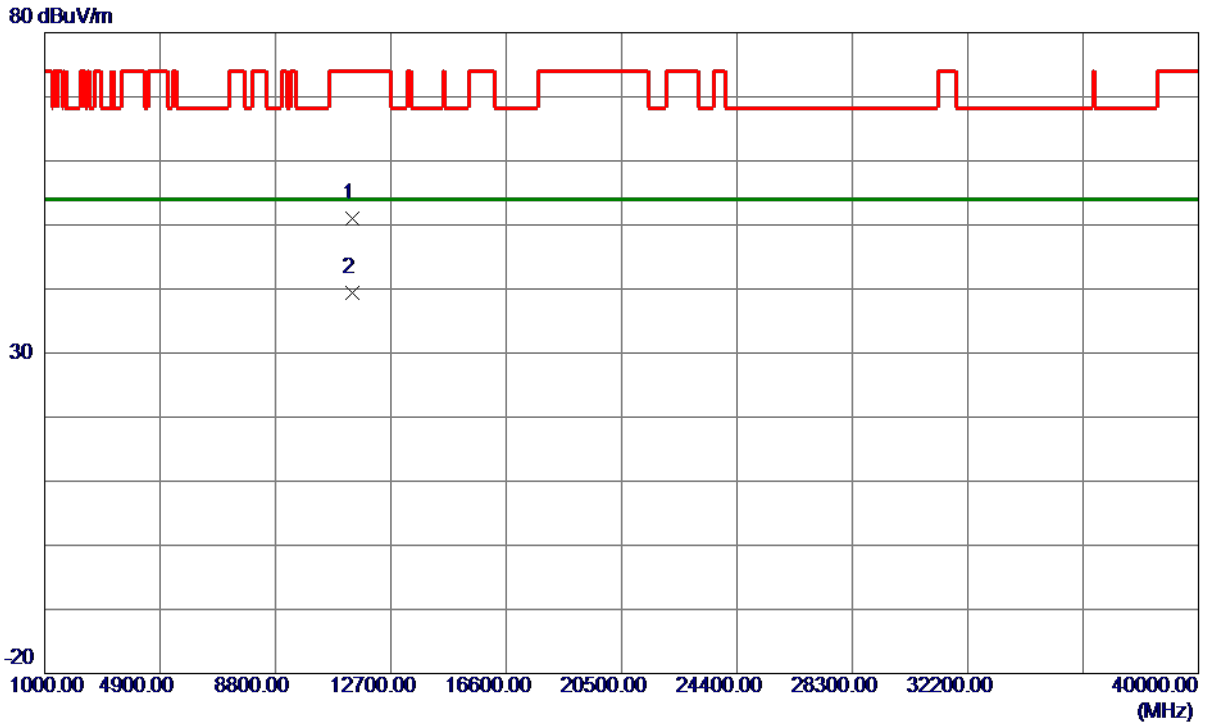

No.	Freq. MHz	Reading Level dBuV/m	Correct Factor dB	Measure ment dBuV/m	Limit dBuV/m	Margin dB	Detector	Comment
1	11409.1400	37.93	13.09	51.02	74.00	-22.98	Peak	
2 *	11409.2850	26.39	13.09	39.48	54.00	-14.52	AVG	

REMARKS:

- (1) Measurement Value = Reading Level + Correct Factor.
- (2) Margin Level = Measurement Value - Limit Value.

Orthogonal Axis	X
Test Mode	UNII-2C_TX AC (VHT40) Mode 5510 MHz

Vertical

130 dBuV/m

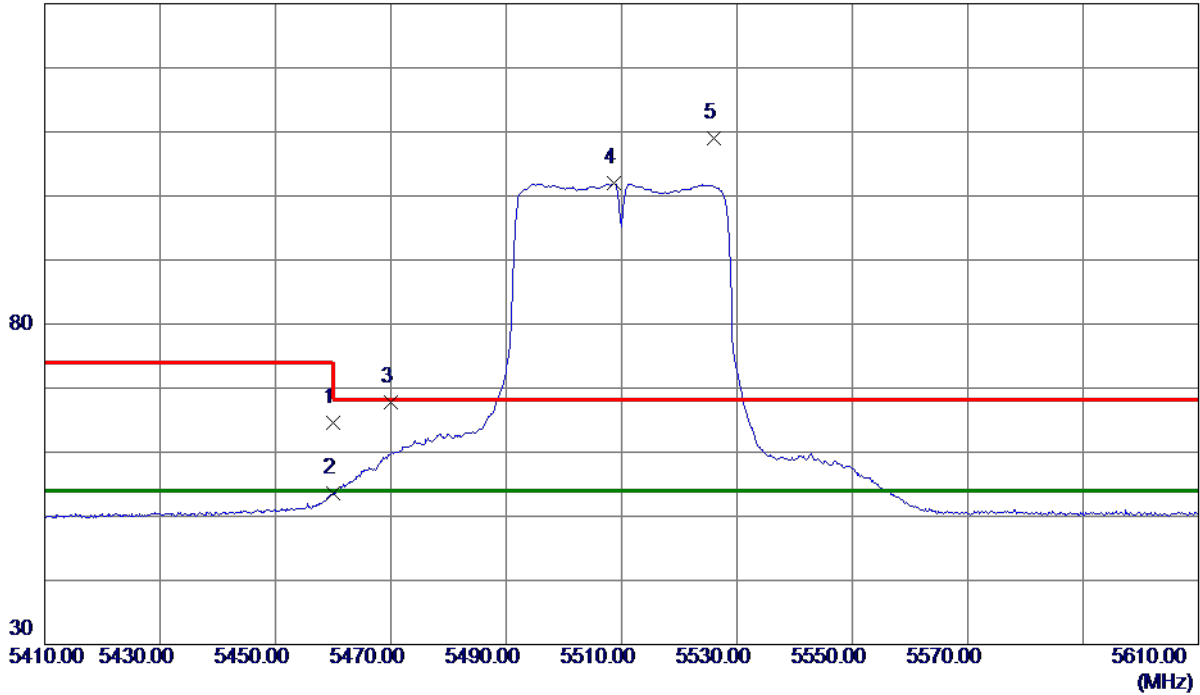

No.	Freq. MHz	Reading Level dBuV/m	Correct Factor dB	Measure ment dBuV/m	Limit dBuV/m	Margin dB	Detector	Comment
1	5460.0000	48.60	15.97	64.57	74.00	-9.43	Peak	
2	5460.0000	37.54	15.97	53.51	54.00	-0.49	AVG	
3	5470.0000	51.75	16.00	67.75	68.30	-0.55	Peak	
4 *	5508.6000	85.83	16.08	101.91	54.00	47.91	AVG	No Limit
5	5526.1000	92.94	16.12	109.06	68.30	40.76	Peak	No Limit

REMARKS:

- (1) Measurement Value = Reading Level + Correct Factor.
- (2) Margin Level = Measurement Value - Limit Value.

Orthogonal Axis	X
Test Mode	UNII-2C_TX AC (VHT40) Mode 5510 MHz

Vertical

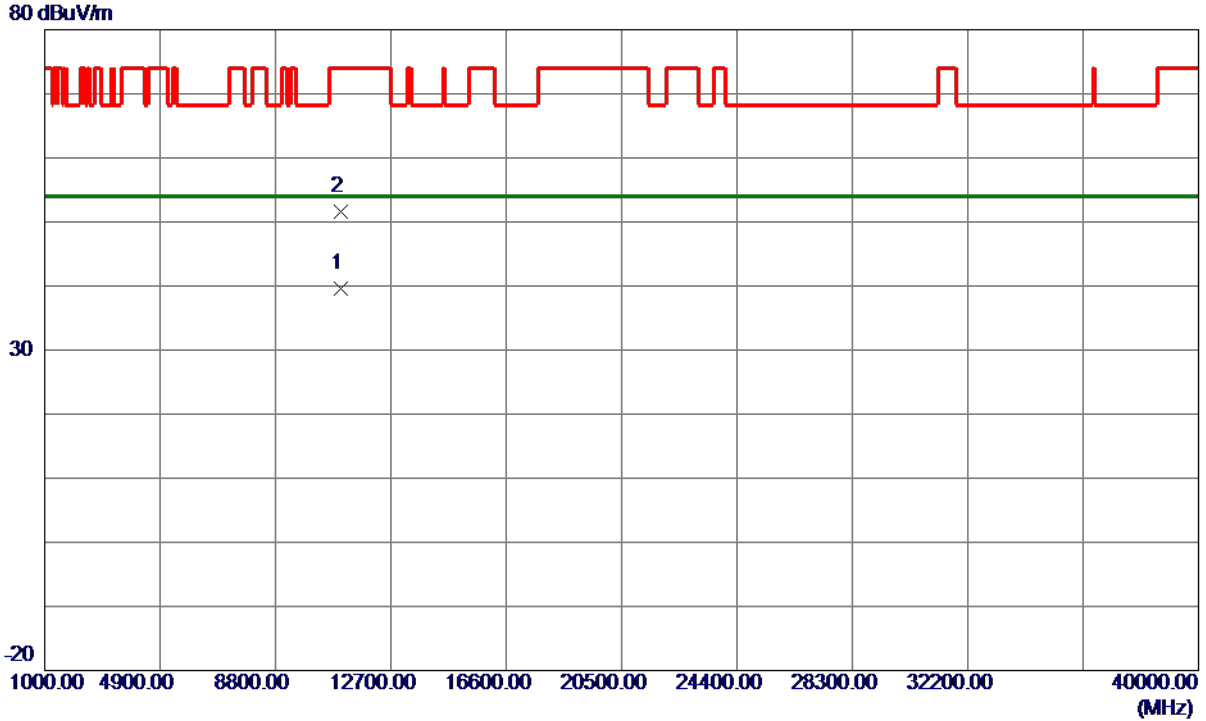

No.	Freq. MHz	Reading Level dBuV/m	Correct Factor dB	Measure ment dBuV/m	Limit dBuV/m	Margin dB	Detector	Comment
1 *	11019.4550	26.80	12.79	39.59	54.00	-14.41	AVG	
2	11019.6950	38.73	12.79	51.52	74.00	-22.48	Peak	

REMARKS:

- (1) Measurement Value = Reading Level + Correct Factor.
- (2) Margin Level = Measurement Value - Limit Value.

Orthogonal Axis	X
Test Mode	UNII-2C_TX AC (VHT40) Mode 5510 MHz

Horizontal

130 dBuV/m

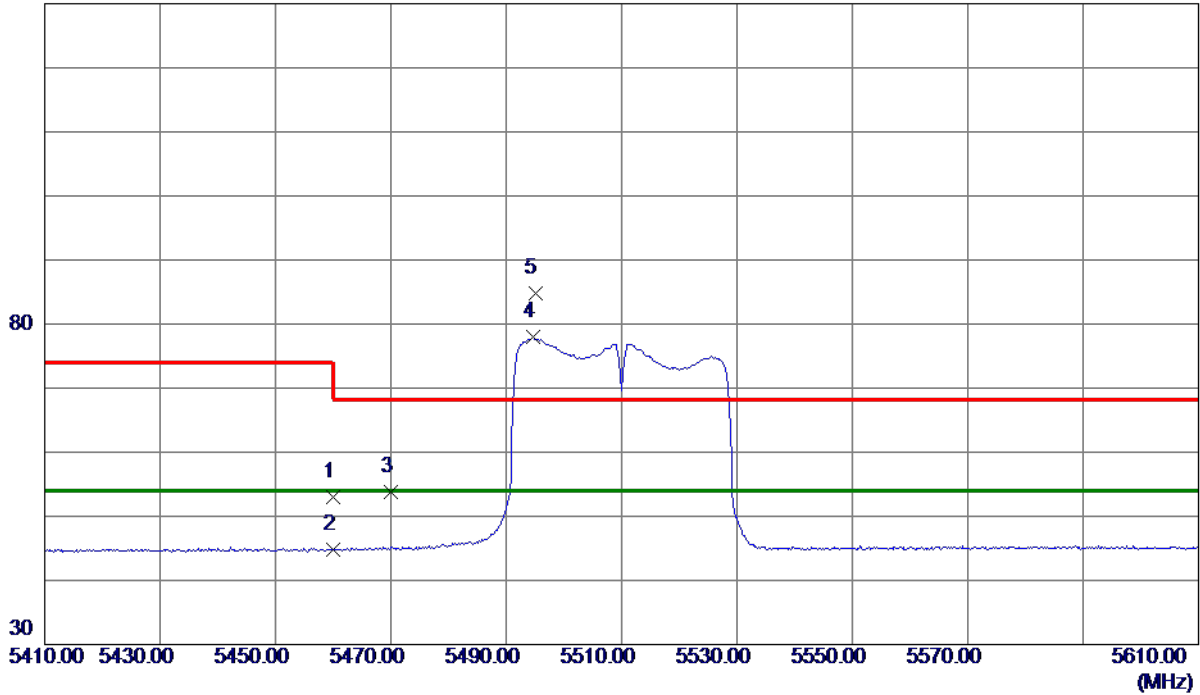

No.	Freq. MHz	Reading Level dBuV/m	Correct Factor dB	Measure ment dBuV/m	Limit dBuV/m	Margin dB	Detector	Comment
1	5460.0000	37.05	15.97	53.02	74.00	-20.98	Peak	
2	5460.0000	28.89	15.97	44.86	54.00	-9.14	AVG	
3	5470.0000	37.85	16.00	53.85	68.30	-14.45	Peak	
4 *	5494.6000	61.86	16.05	77.91	54.00	23.91	AVG	No Limit
5	5495.0000	68.67	16.05	84.72	68.30	16.42	Peak	No Limit

REMARKS:

- (1) Measurement Value = Reading Level + Correct Factor.
- (2) Margin Level = Measurement Value - Limit Value.

Orthogonal Axis	X
Test Mode	UNII-2C_TX AC (VHT40) Mode 5510 MHz

Horizontal

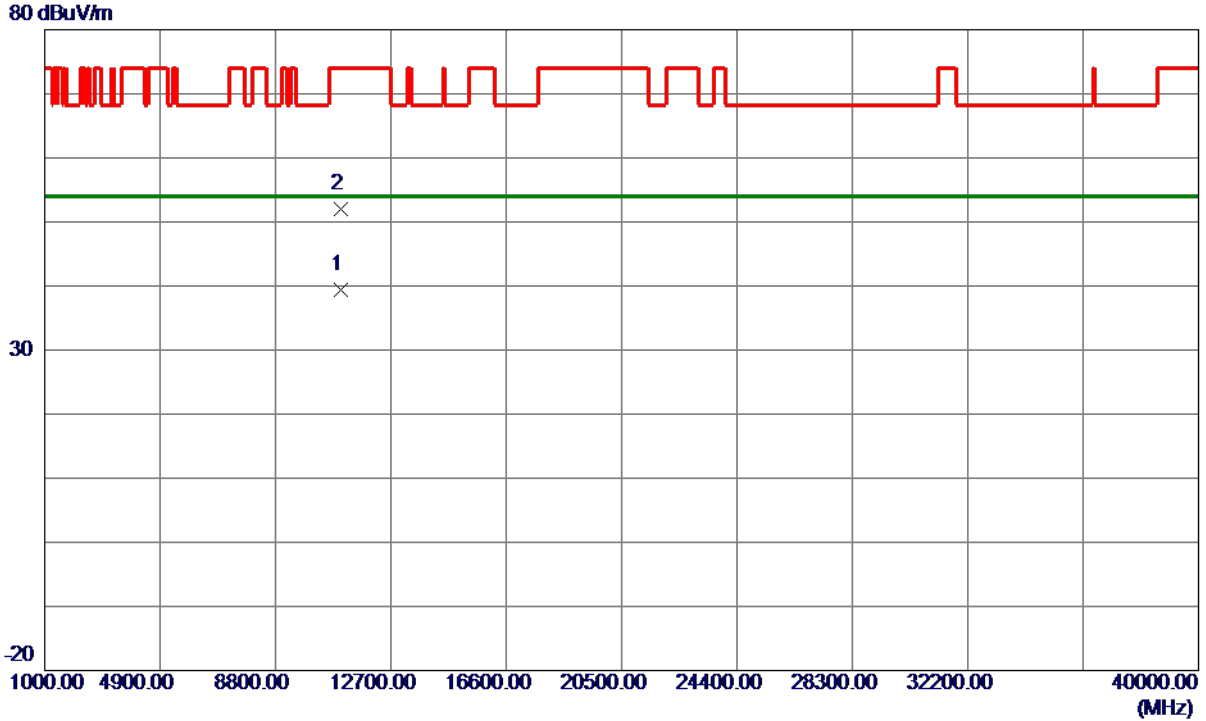

No.	Freq. MHz	Reading Level dBuV/m	Correct Factor dB	Measure ment dBuV/m	Limit dBuV/m	Margin dB	Detector	Comment
1 *	11019.2300	26.61	12.79	39.40	54.00	-14.60	AVG	
2	11020.3250	39.20	12.80	52.00	74.00	-22.00	Peak	

REMARKS:

- (1) Measurement Value = Reading Level + Correct Factor.
- (2) Margin Level = Measurement Value - Limit Value.

Orthogonal Axis	X
Test Mode	UNII-2C_TX AC (VHT40) Mode 5550 MHz

Vertical

130 dBuV/m

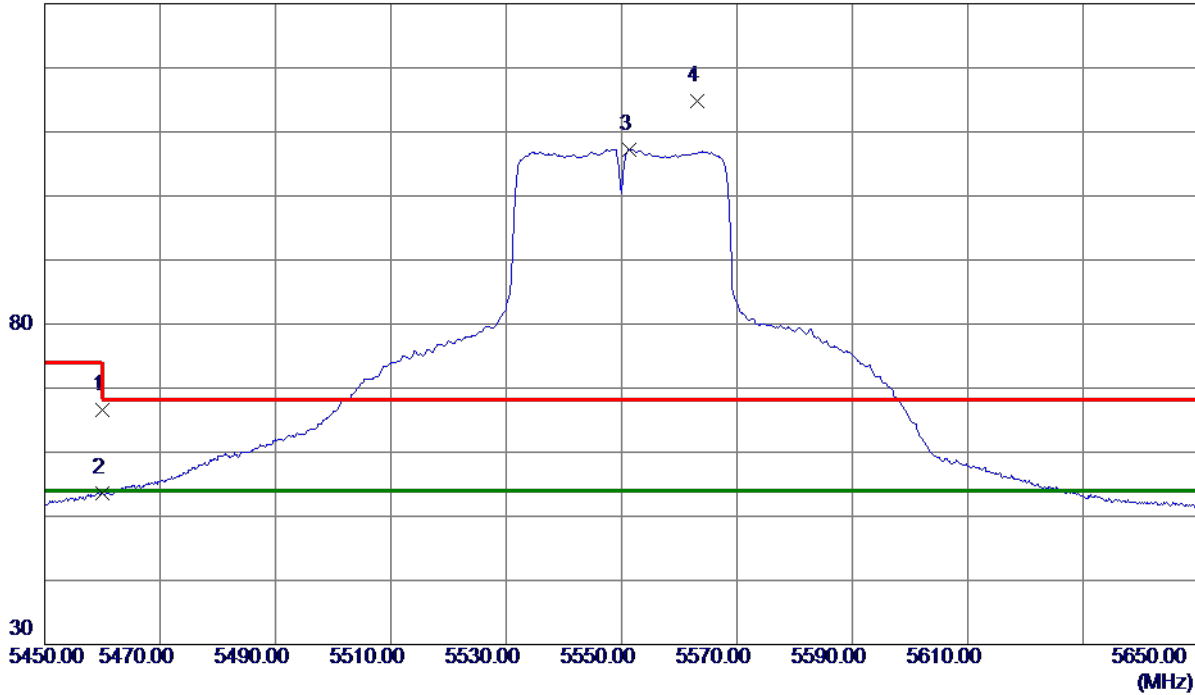

No.	Freq. MHz	Reading Level dBuV/m	Correct Factor dB	Measure ment dBuV/m	Limit dBuV/m	Margin dB	Detector	Comment
1	5460.0000	50.64	15.97	66.61	74.00	-7.39	Peak	
2	5460.0000	37.54	15.97	53.51	54.00	-0.49	AVG	
3 *	5551.4000	91.12	16.17	107.29	54.00	53.29	AVG	No Limit
4	5563.1000	98.64	16.19	114.83	68.30	46.53	Peak	No Limit

REMARKS:

- (1) Measurement Value = Reading Level + Correct Factor.
- (2) Margin Level = Measurement Value - Limit Value.

Orthogonal Axis	X
Test Mode	UNII-2C_TX AC (VHT40) Mode 5550 MHz

Vertical

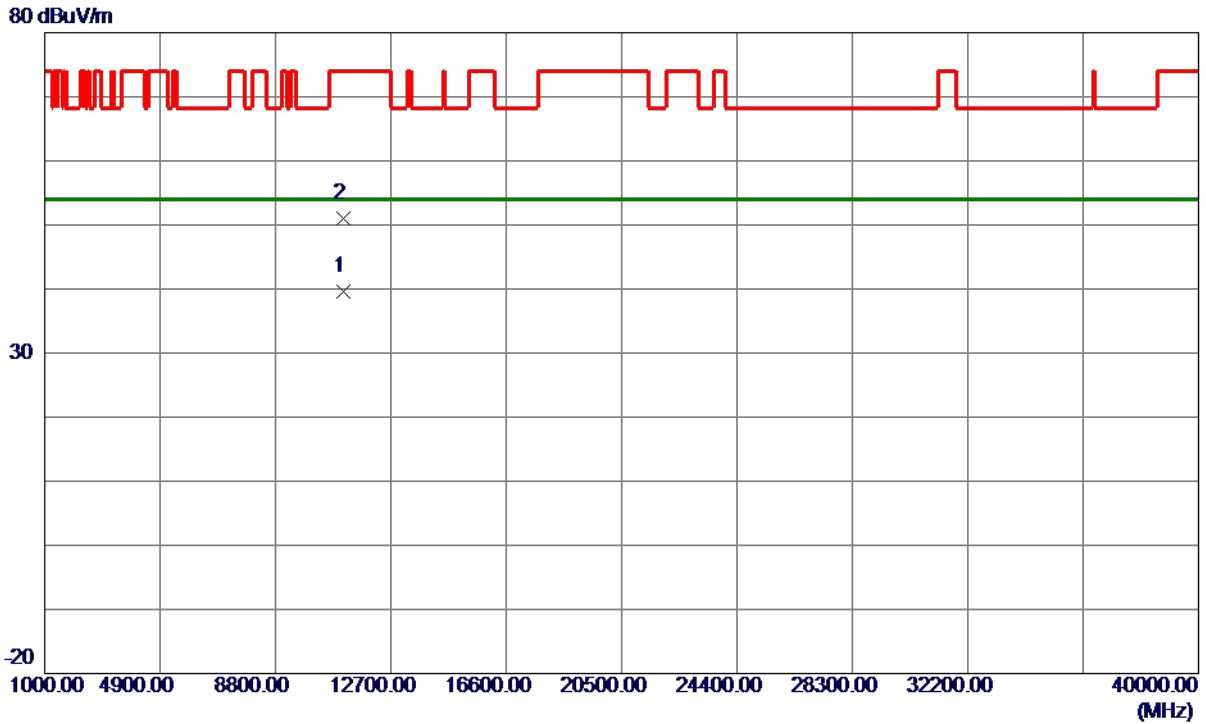

No.	Freq. MHz	Reading Level dBuV/m	Correct Factor dB	Measure ment dBuV/m	Limit dBuV/m	Margin dB	Detector	Comment
1 *	11097.6800	26.66	12.85	39.51	54.00	-14.49	AVG	
2	11100.8850	38.07	12.86	50.93	74.00	-23.07	Peak	

REMARKS:

- (1) Measurement Value = Reading Level + Correct Factor.
- (2) Margin Level = Measurement Value - Limit Value.

Orthogonal Axis	X
Test Mode	UNII-2C_TX AC (VHT40) Mode 5550 MHz

Horizontal

130 dBuV/m

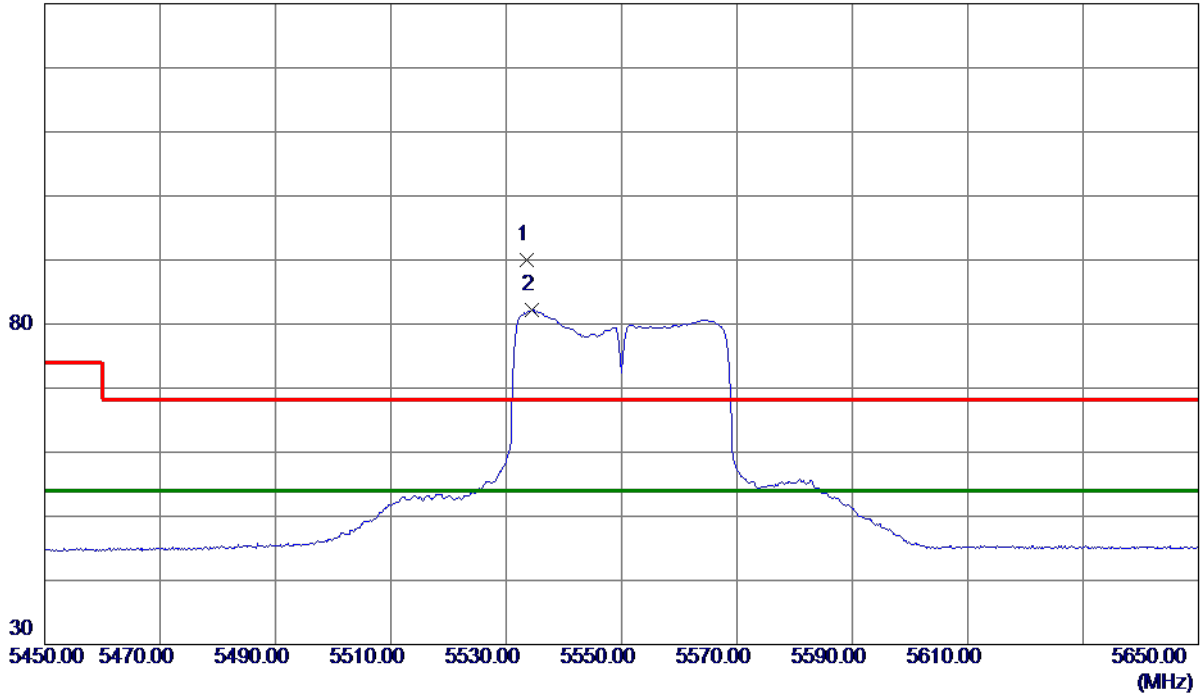

No.	Freq. MHz	Reading Level dBuV/m	Correct Factor dB	Measure ment dBuV/m	Limit dBuV/m	Margin dB	Detector	Comment
1	5533.6000	73.83	16.13	89.96	68.30	21.66	Peak	No Limit
2 *	5534.4000	66.05	16.13	82.18	54.00	28.18	AVG	No Limit

REMARKS:

- (1) Measurement Value = Reading Level + Correct Factor.
- (2) Margin Level = Measurement Value - Limit Value.

Orthogonal Axis	X
Test Mode	UNII-2C_TX AC (VHT40) Mode 5550 MHz

Horizontal

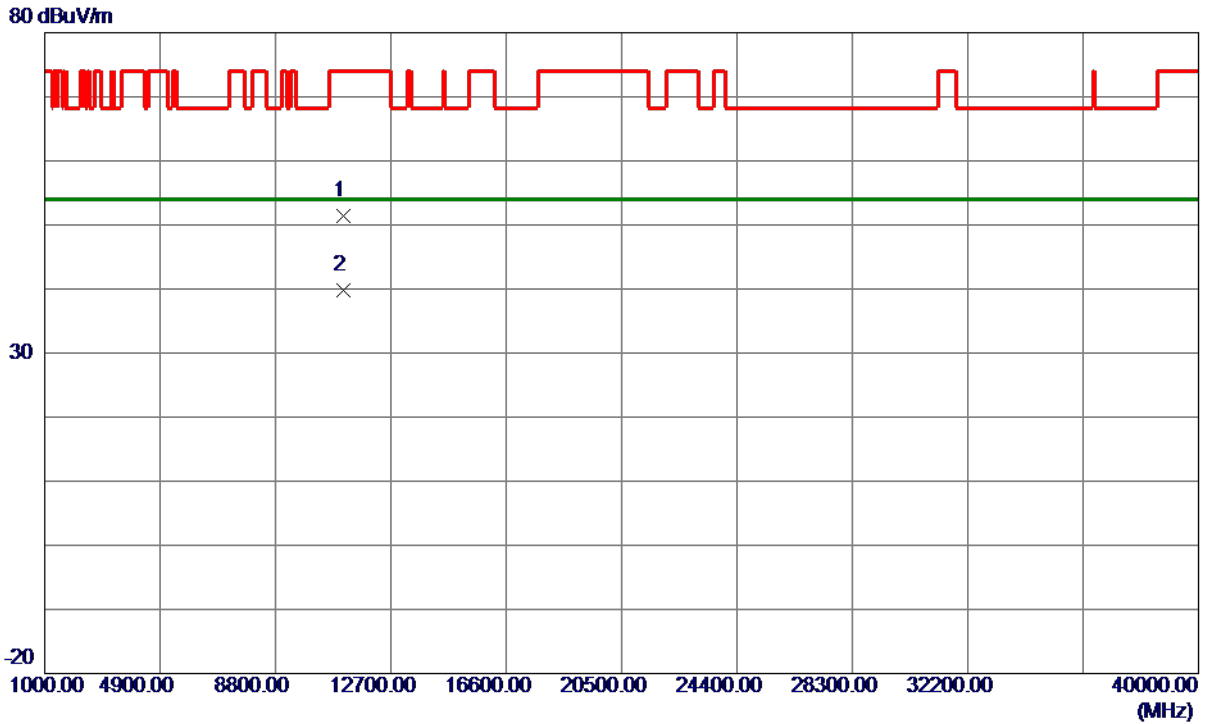

No.	Freq. MHz	Reading Level dBuV/m	Correct Factor dB	Measure ment dBuV/m	Limit dBuV/m	Margin dB	Detector	Comment
1	11100.3750	38.48	12.86	51.34	74.00	-22.66	Peak	
2 *	11101.2150	26.89	12.86	39.75	54.00	-14.25	AVG	

REMARKS:

- (1) Measurement Value = Reading Level + Correct Factor.
- (2) Margin Level = Measurement Value - Limit Value.

Orthogonal Axis	X
Test Mode	UNII-2C_TX AC (VHT40) Mode 5670 MHz

Vertical

130 dBuV/m

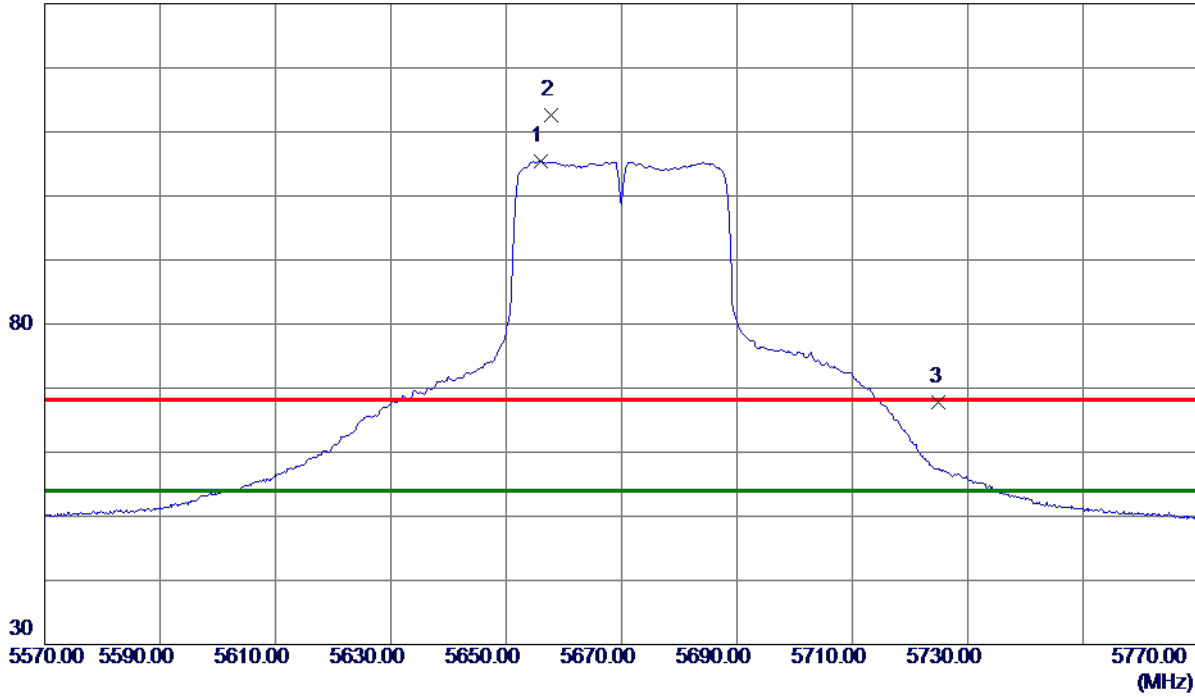

No.	Freq. MHz	Reading Level dBuV/m	Correct Factor dB	Measure ment dBuV/m	Limit dBuV/m	Margin dB	Detector	Comment
1 *	5656.0000	89.00	16.38	105.38	54.00	51.38	AVG	No Limit
2	5657.7000	96.17	16.38	112.55	68.30	44.25	Peak	No Limit
3	5725.0000	51.33	16.51	67.84	68.30	-0.46	Peak	

REMARKS:

- (1) Measurement Value = Reading Level + Correct Factor.
- (2) Margin Level = Measurement Value - Limit Value.

Orthogonal Axis	X
Test Mode	UNII-2C_TX AC (VHT40) Mode 5670 MHz

Vertical

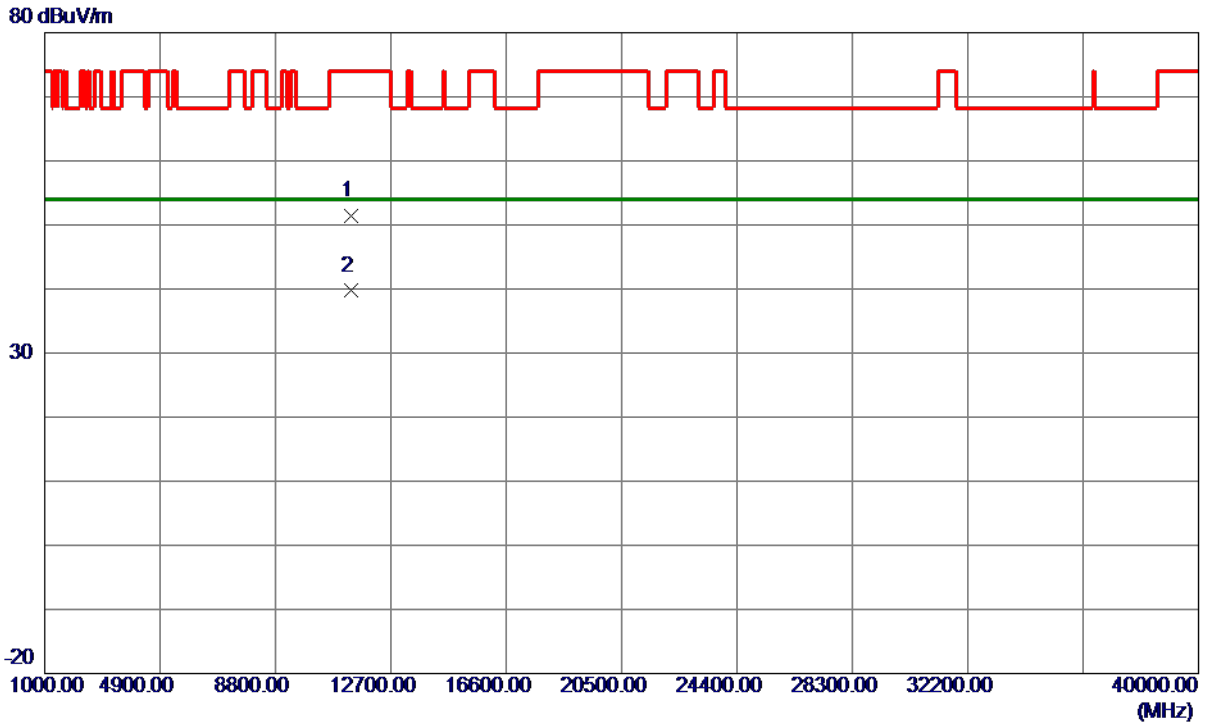

No.	Freq. MHz	Reading Level dBuV/m	Correct Factor dB	Measure ment dBuV/m	Limit dBuV/m	Margin dB	Detector	Comment
1	11337.7450	38.43	13.03	51.46	74.00	-22.54	Peak	
2 *	11340.8650	26.66	13.04	39.70	54.00	-14.30	AVG	

REMARKS:

- (1) Measurement Value = Reading Level + Correct Factor.
- (2) Margin Level = Measurement Value - Limit Value.

Orthogonal Axis	X
Test Mode	UNII-2C_TX AC (VHT40) Mode 5670 MHz

Horizontal

130 dBuV/m

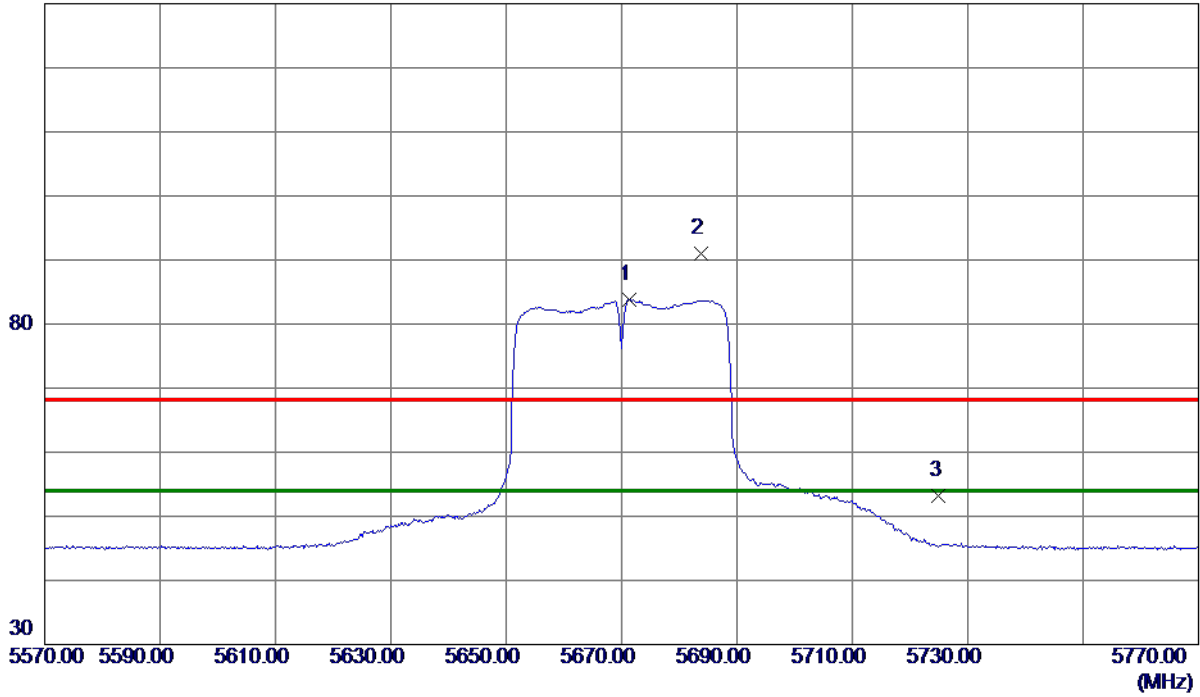

No.	Freq. MHz	Reading Level dBuV/m	Correct Factor dB	Measure ment dBuV/m	Limit dBuV/m	Margin dB	Detector	Comment
1 *	5671.4000	67.42	16.41	83.83	54.00	29.83	AVG	No Limit
2	5683.8000	74.48	16.43	90.91	68.30	22.61	Peak	No Limit
3	5725.0000	36.75	16.51	53.26	68.30	-15.04	Peak	

REMARKS:

- (1) Measurement Value = Reading Level + Correct Factor.
- (2) Margin Level = Measurement Value - Limit Value.

Orthogonal Axis	X
Test Mode	UNII-2C_TX AC (VHT40) Mode 5670 MHz

Horizontal

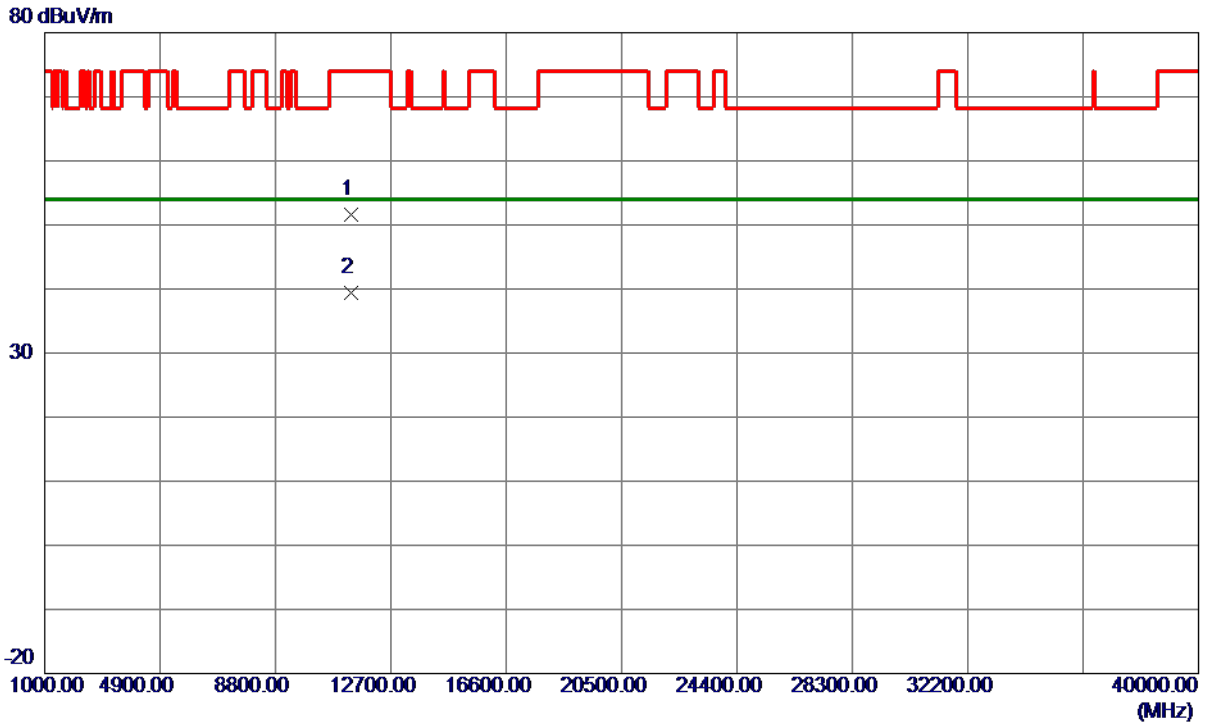

No.	Freq. MHz	Reading Level dBuV/m	Correct Factor dB	Measure ment dBuV/m	Limit dBuV/m	Margin dB	Detector	Comment
1	11340.9150	38.57	13.04	51.61	74.00	-22.39	Peak	
2 *	11341.1000	26.28	13.04	39.32	54.00	-14.68	AVG	

REMARKS:

- (1) Measurement Value = Reading Level + Correct Factor.
- (2) Margin Level = Measurement Value - Limit Value.

Orthogonal Axis	X
Test Mode	UNII-2C_TX AC (VHT80) Mode 5530 MHz

Vertical

130 dBuV/m

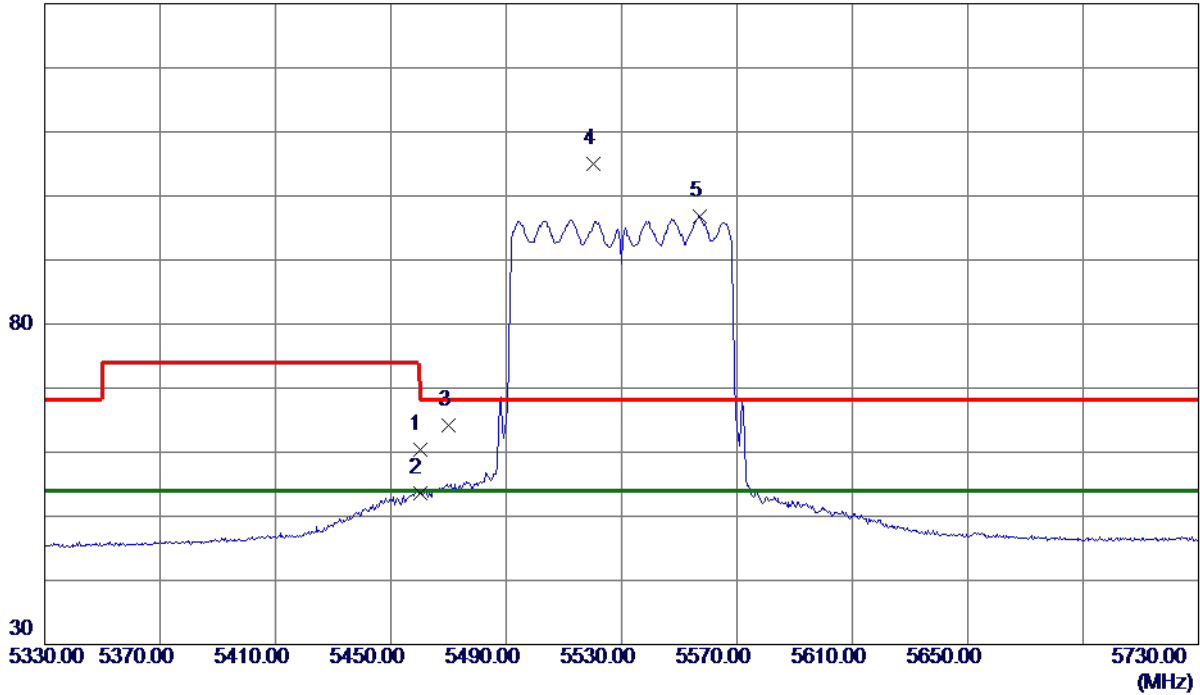

No.	Freq. MHz	Reading Level dBuV/m	Correct Factor dB	Measure ment dBuV/m	Limit dBuV/m	Margin dB	Detector	Comment
1	5460.0000	44.36	15.97	60.33	74.00	-13.67	Peak	
2	5460.0000	37.69	15.97	53.66	54.00	-0.34	AVG	
3	5470.0000	48.27	16.00	64.27	68.30	-4.03	Peak	
4	5520.4000	88.87	16.11	104.98	68.30	36.68	Peak	No Limit
5 *	5557.2000	80.62	16.18	96.80	54.00	42.80	AVG	No Limit

REMARKS:

- (1) Measurement Value = Reading Level + Correct Factor.
- (2) Margin Level = Measurement Value - Limit Value.

Orthogonal Axis	X
Test Mode	UNII-2C_TX AC (VHT80) Mode 5530 MHz

Vertical

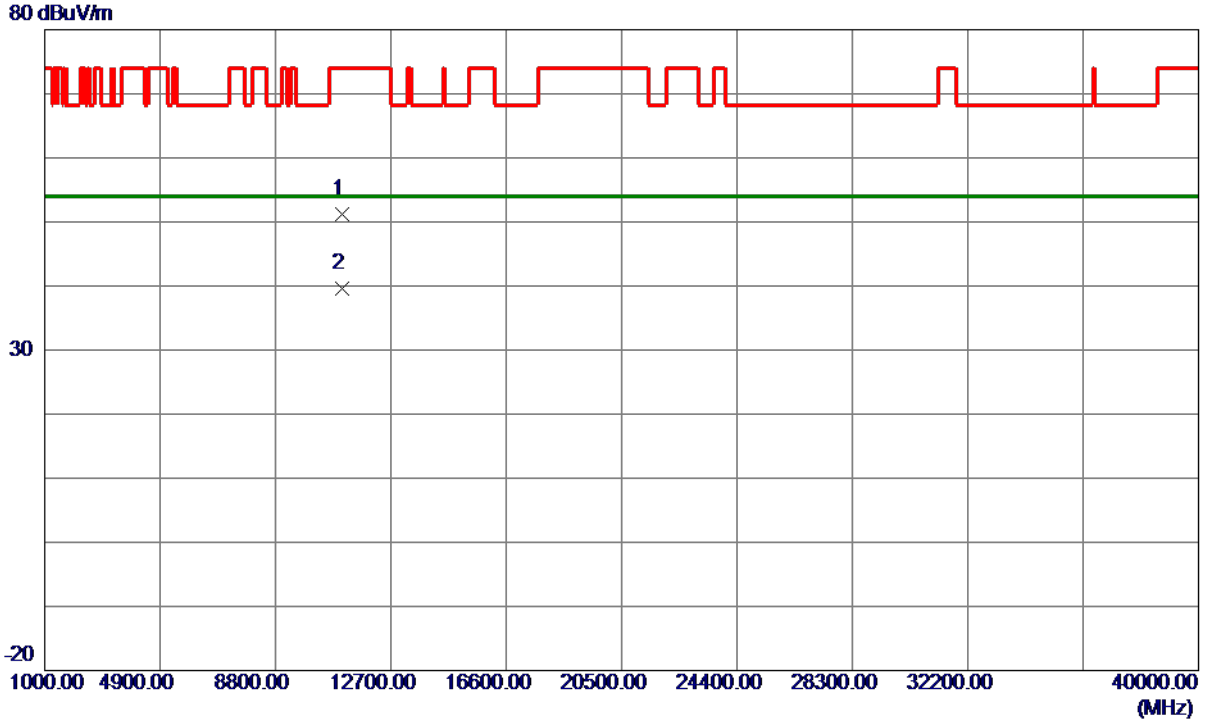

No.	Freq. MHz	Reading Level dBuV/m	Correct Factor dB	Measure ment dBuV/m	Limit dBuV/m	Margin dB	Detector	Comment
1	11058.9349	38.31	12.82	51.13	74.00	-22.87	Peak	
2 *	11059.2650	26.71	12.82	39.53	54.00	-14.47	AVG	

REMARKS:

- (1) Measurement Value = Reading Level + Correct Factor.
- (2) Margin Level = Measurement Value - Limit Value.

Orthogonal Axis	X
Test Mode	UNII-2C_TX AC (VHT80) Mode 5530 MHz

Horizontal

130 dBuV/m

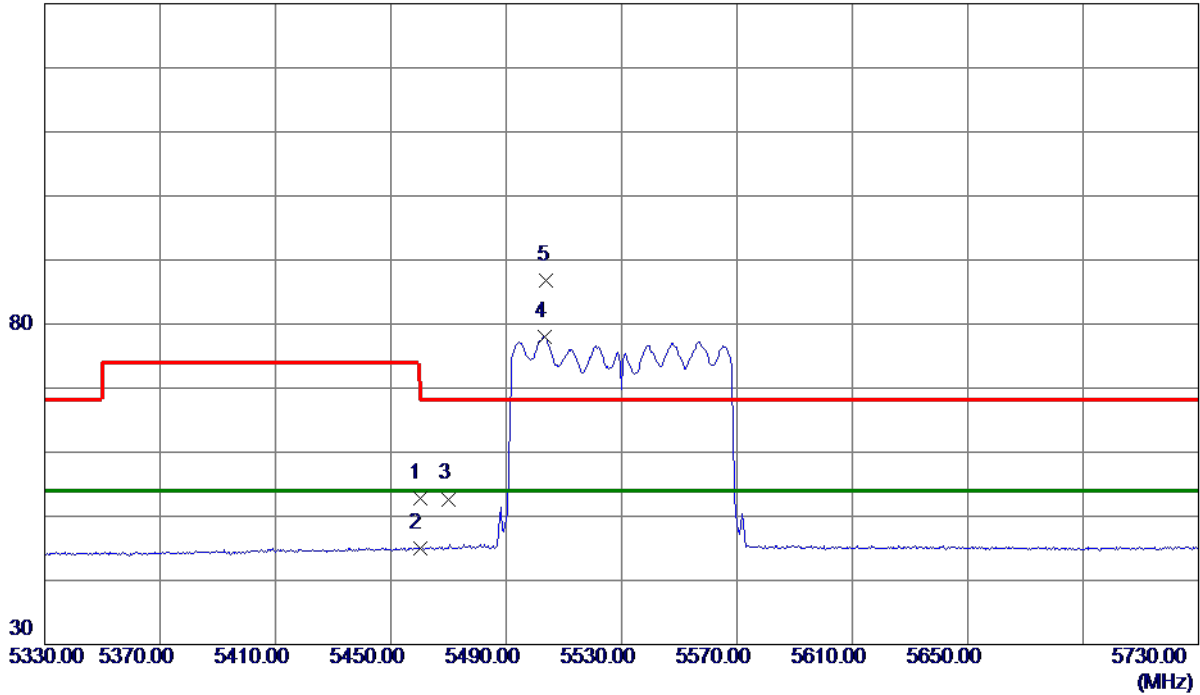

No.	Freq. MHz	Reading Level dBuV/m	Correct Factor dB	Measure ment dBuV/m	Limit dBuV/m	Margin dB	Detector	Comment
1	5460.0000	36.76	15.97	52.73	74.00	-21.27	Peak	
2	5460.0000	28.99	15.97	44.96	54.00	-9.04	AVG	
3	5470.0000	36.70	16.00	52.70	68.30	-15.60	Peak	
4 *	5503.2000	61.95	16.07	78.02	54.00	24.02	AVG	No Limit
5	5504.0000	70.72	16.07	86.79	68.30	18.49	Peak	No Limit

REMARKS:

- (1) Measurement Value = Reading Level + Correct Factor.
- (2) Margin Level = Measurement Value - Limit Value.

Orthogonal Axis	X
Test Mode	UNII-2C_TX AC (VHT80) Mode 5530 MHz

Horizontal

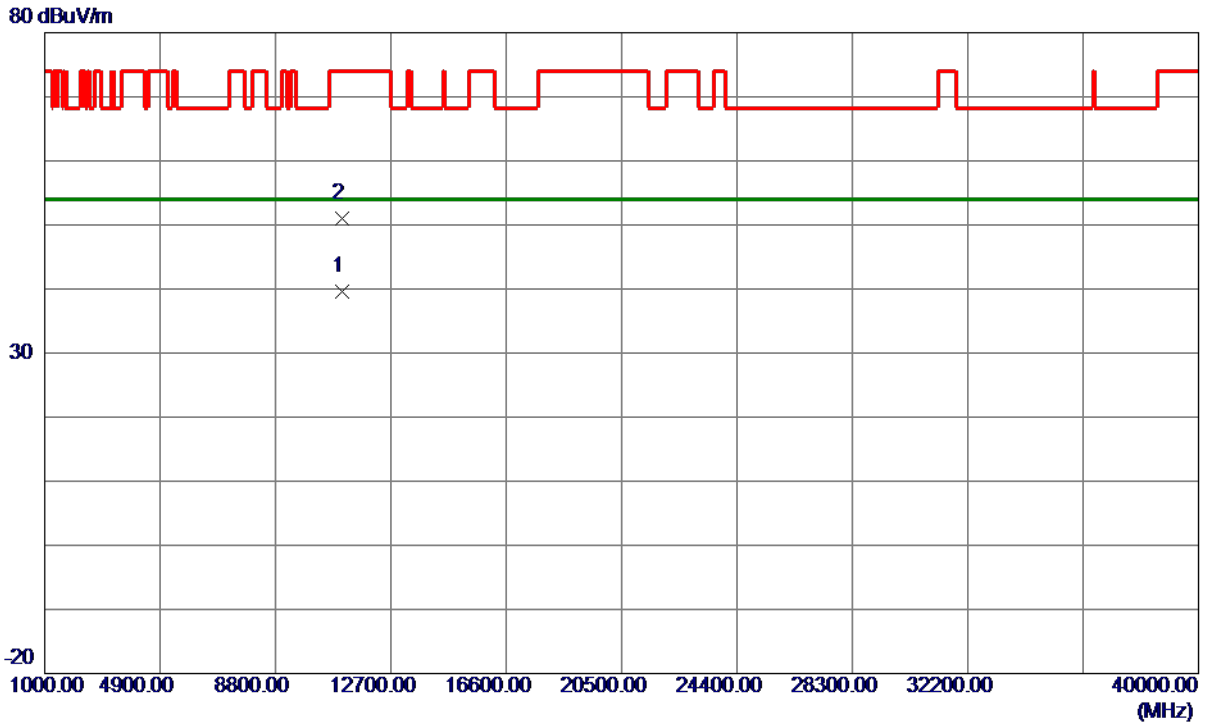

No.	Freq. MHz	Reading Level dBuV/m	Correct Factor dB	Measure ment dBuV/m	Limit dBuV/m	Margin dB	Detector	Comment
1 *	11058.4300	26.77	12.82	39.59	54.00	-14.41	AVG	
2	11061.8200	38.11	12.83	50.94	74.00	-23.06	Peak	

REMARKS:

- (1) Measurement Value = Reading Level + Correct Factor.
- (2) Margin Level = Measurement Value - Limit Value.

Orthogonal Axis	X
Test Mode	UNII-2C_TX AC (VHT80) Mode 5610 MHz

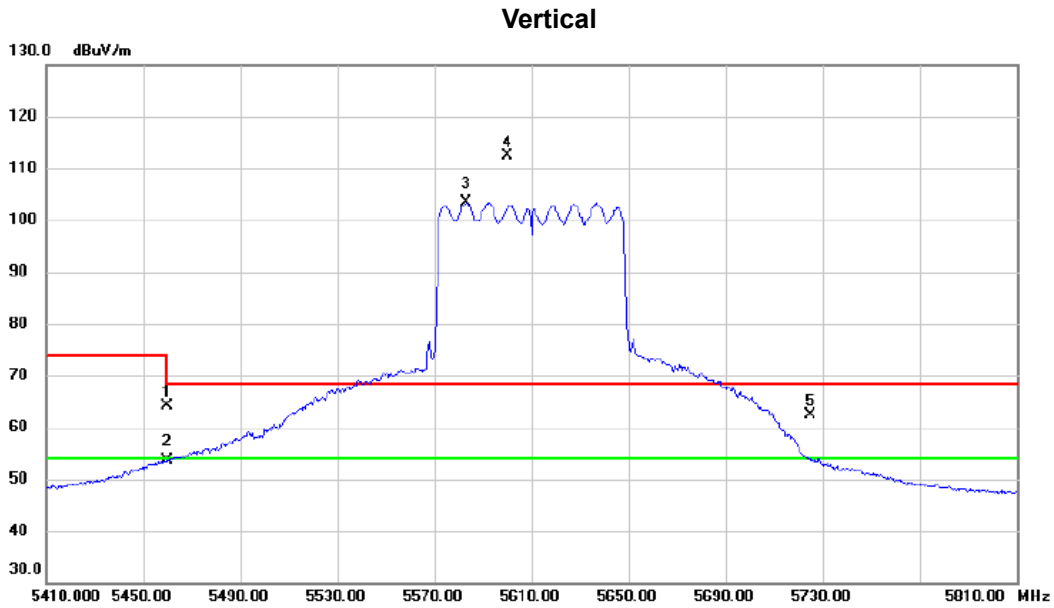

No.	Mk.	Freq. MHz	Reading Level dBuV	Correct Factor dB	Measure- ment dBuV/m	Limit dBuV/m	Margin dB	Detector	Comment
1		5460.000	48.04	15.98	64.02	74.00	-9.98	peak	
2		5460.000	37.67	15.98	53.65	54.00	-0.35	AVG	
3	*	5583.200	87.24	16.23	103.47	54.00	49.47	AVG	No Limit
4	X	5600.400	96.12	16.26	112.38	68.30	44.08	peak	No Limit
5		5725.000	45.97	16.51	62.48	68.30	-5.82	peak	

REMARKS:

- (1) Measurement Value = Reading Level + Correct Factor.
- (2) Margin Level = Measurement Value - Limit Value.

Orthogonal Axis	X
Test Mode	UNII-2C_TX AC (VHT80) Mode 5610 MHz

Vertical

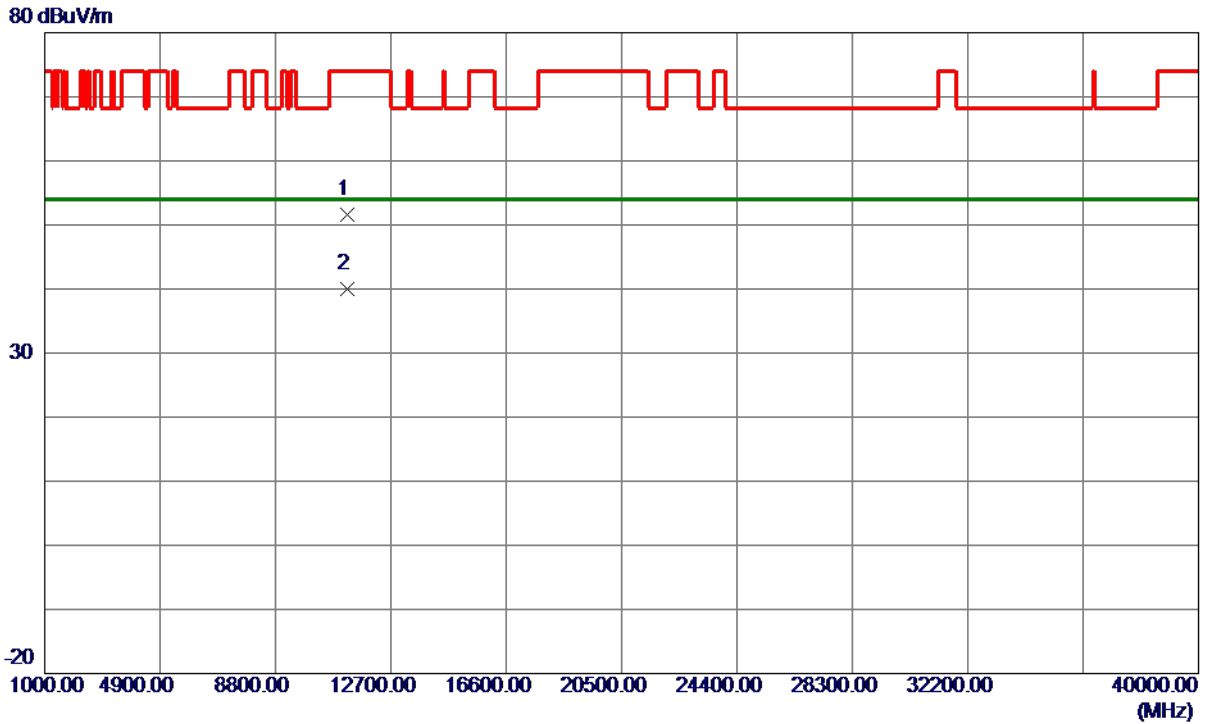

No.	Freq. MHz	Reading Level dBuV/m	Correct Factor dB	Measure ment dBuV/m	Limit dBuV/m	Margin dB	Detector	Comment
1	11217.6700	38.65	12.94	51.59	74.00	-22.41	Peak	
2 *	11222.4450	27.04	12.95	39.99	54.00	-14.01	AVG	

REMARKS:

- (1) Measurement Value = Reading Level + Correct Factor.
- (2) Margin Level = Measurement Value - Limit Value.

Orthogonal Axis	X
Test Mode	UNII-2C_TX AC (VHT80) Mode 5610 MHz

Horizontal

130 dBuV/m

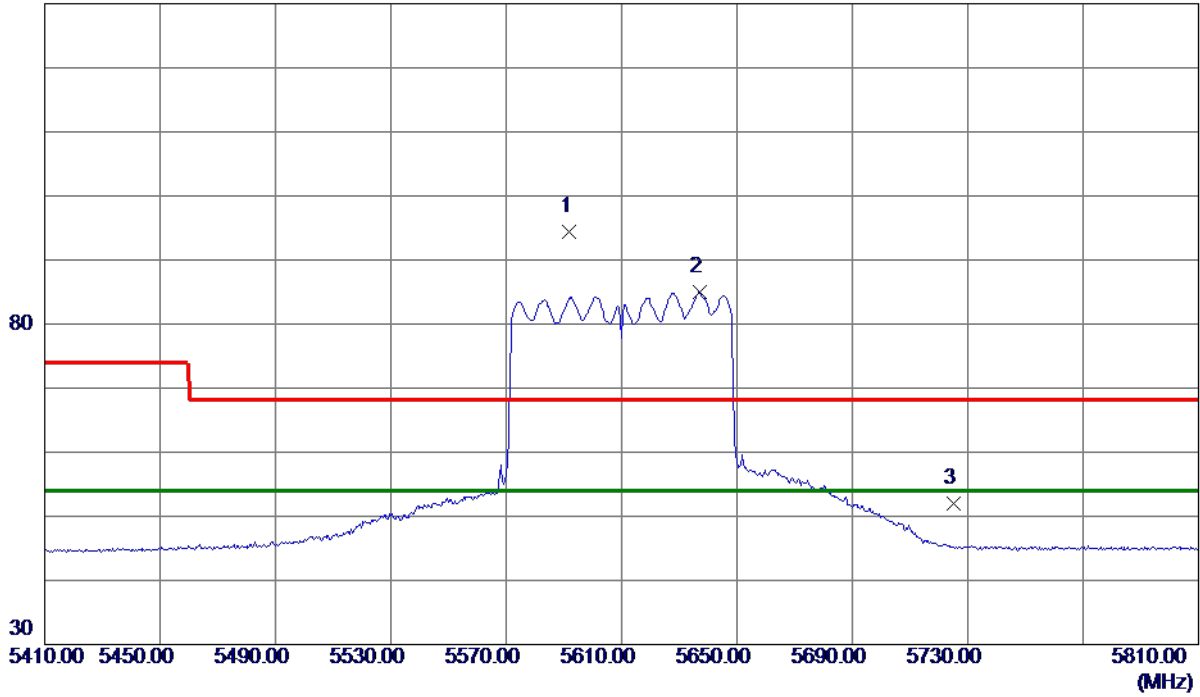

No.	Freq. MHz	Reading Level dBuV/m	Correct Factor dB	Measure ment dBuV/m	Limit dBuV/m	Margin dB	Detector	Comment
1	5592.0000	78.19	16.25	94.44	68.30	26.14	Peak	No Limit
2 *	5637.2000	68.75	16.34	85.09	54.00	31.09	AVG	No Limit
3	5725.0000	35.52	16.51	52.03	68.30	-16.27	Peak	

REMARKS:

- (1) Measurement Value = Reading Level + Correct Factor.
- (2) Margin Level = Measurement Value - Limit Value.

Orthogonal Axis	X
Test Mode	UNII-2C_TX AC (VHT80) Mode 5610 MHz

Horizontal

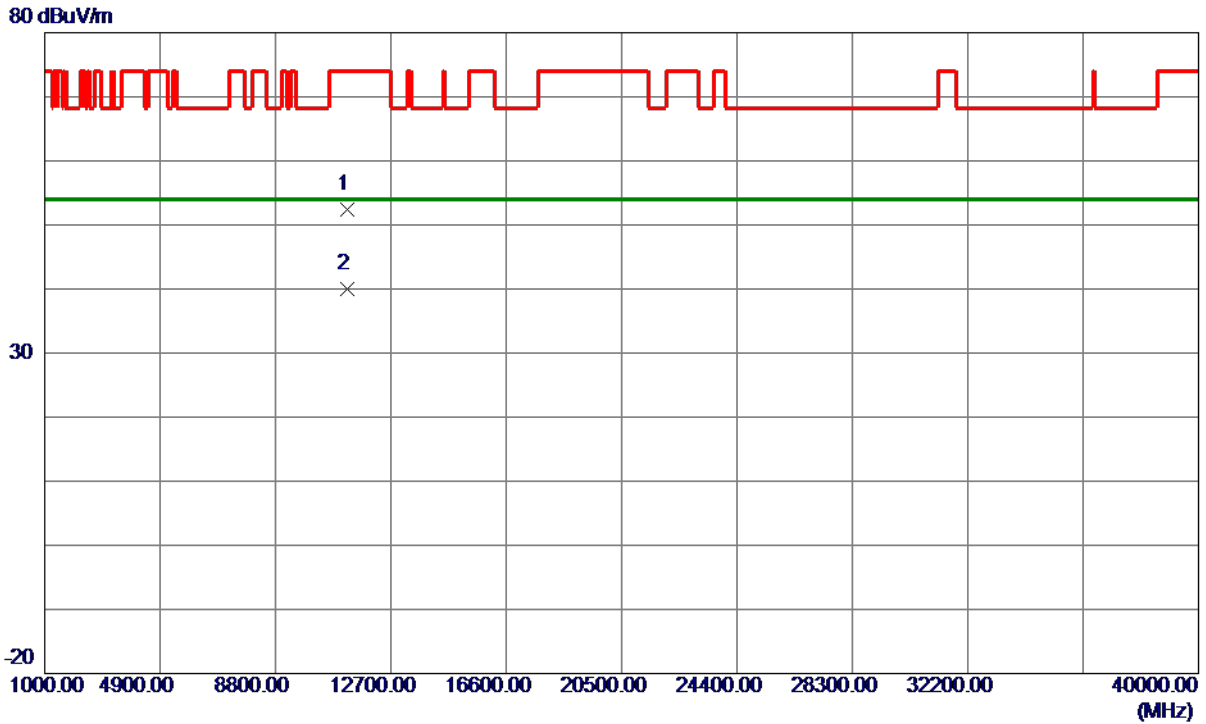

No.	Freq. MHz	Reading Level dBuV/m	Correct Factor dB	Measure ment dBuV/m	Limit dBuV/m	Margin dB	Detector	Comment
1	11220.7750	39.53	12.95	52.48	74.00	-21.52	Peak	
2 *	11221.4349	27.03	12.95	39.98	54.00	-14.02	AVG	

REMARKS:

- (1) Measurement Value = Reading Level + Correct Factor.
- (2) Margin Level = Measurement Value - Limit Value.

Orthogonal Axis	X
Test Mode	UNII-3_TX AC (VHT20) Mode 5745 MHz

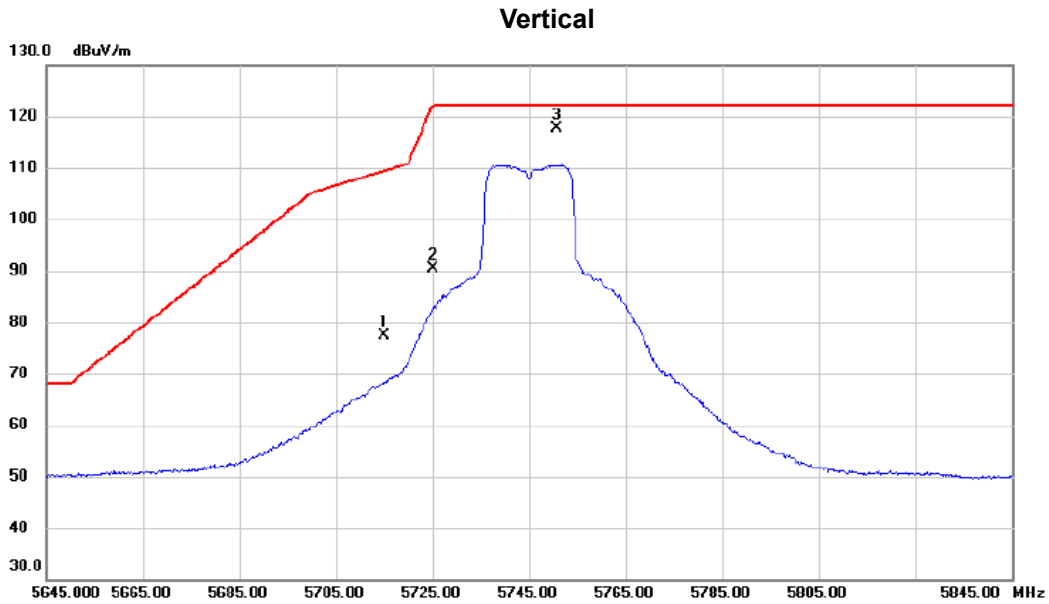

No. Mk.	Freq. MHz	Reading Level dBuV	Correct Factor dB	Measurement dBuV/m	Limit dBuV/m	Margin dB	Detector	Comment
1	5715.000	60.83	16.49	77.32	109.40	-32.08	peak	
2	5725.000	73.95	16.51	90.46	122.20	-31.74	peak	
3 *	5750.700	100.97	16.56	117.53	122.20	-4.67	peak	No Limit

REMARKS:

- (1) Measurement Value = Reading Level + Correct Factor.
- (2) Margin Level = Measurement Value - Limit Value.

Orthogonal Axis	X
Test Mode	UNII-3_TX AC (VHT20) Mode 5745 MHz

Vertical

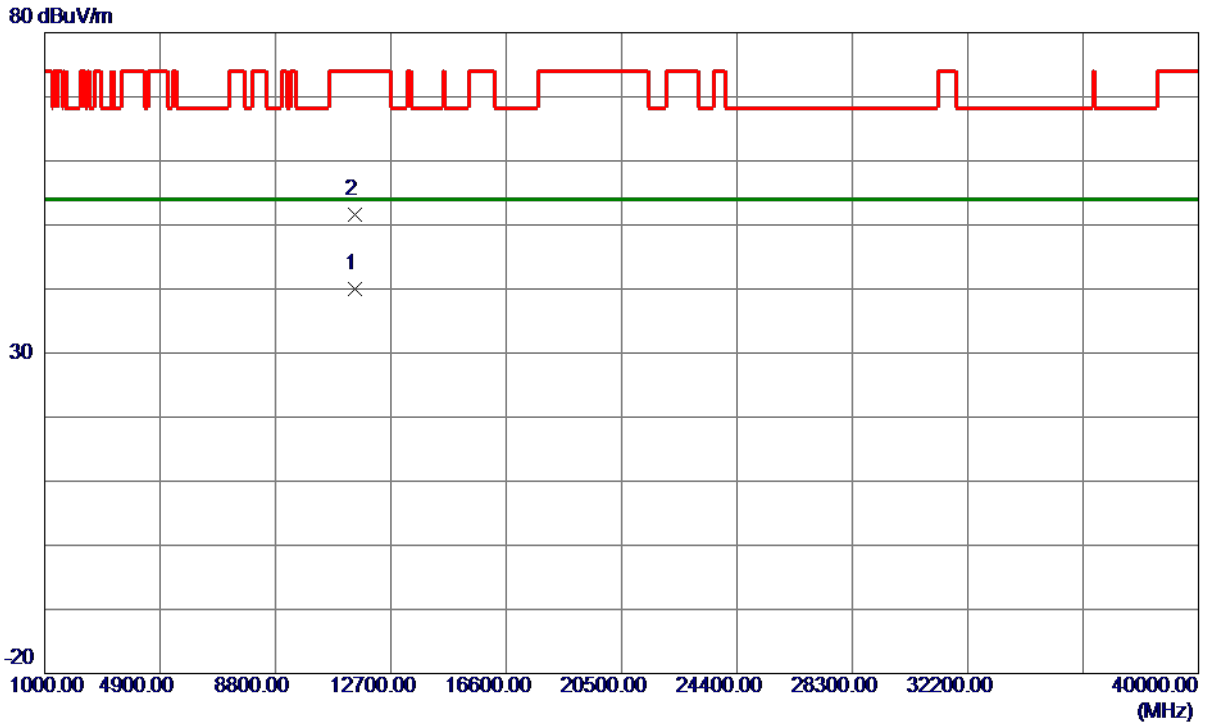

No.	Freq. MHz	Reading Level dBuV/m	Correct Factor dB	Measure ment dBuV/m	Limit dBuV/m	Margin dB	Detector	Comment
1 *	11490.6350	26.92	13.15	40.07	54.00	-13.93	AVG	
2	11491.7500	38.38	13.15	51.53	74.00	-22.47	Peak	

REMARKS:

- (1) Measurement Value = Reading Level + Correct Factor.
- (2) Margin Level = Measurement Value - Limit Value.

Orthogonal Axis	X
Test Mode	UNII-3_TX AC (VHT20) Mode 5745 MHz

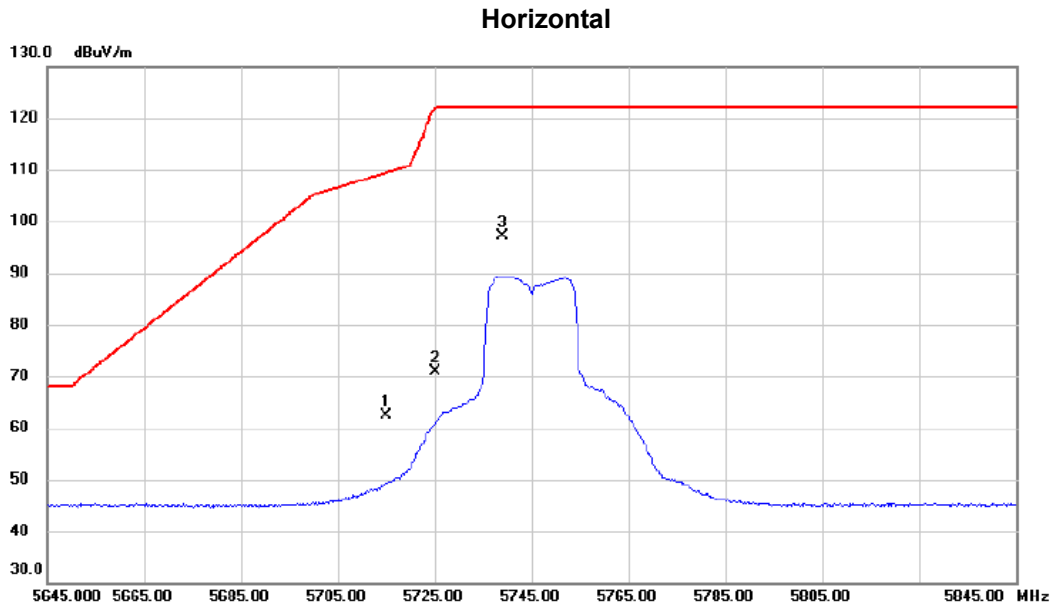

No.	Mk.	Freq. MHz	Reading Level dBuV	Correct Factor dB	Measure- ment dBuV/m	Limit dBuV/m	Margin dB	Detector	Comment
1		5715.000	45.91	16.49	62.40	109.40	-47.00	peak	
2		5725.000	54.26	16.51	70.77	122.20	-51.43	peak	
3	*	5739.000	80.54	16.54	97.08	122.20	-25.12	peak	No Limit

REMARKS:

- (1) Measurement Value = Reading Level + Correct Factor.
- (2) Margin Level = Measurement Value - Limit Value.

Orthogonal Axis	X
Test Mode	UNII-3_TX AC (VHT20) Mode 5745 MHz

Horizontal

80 dBuV/m

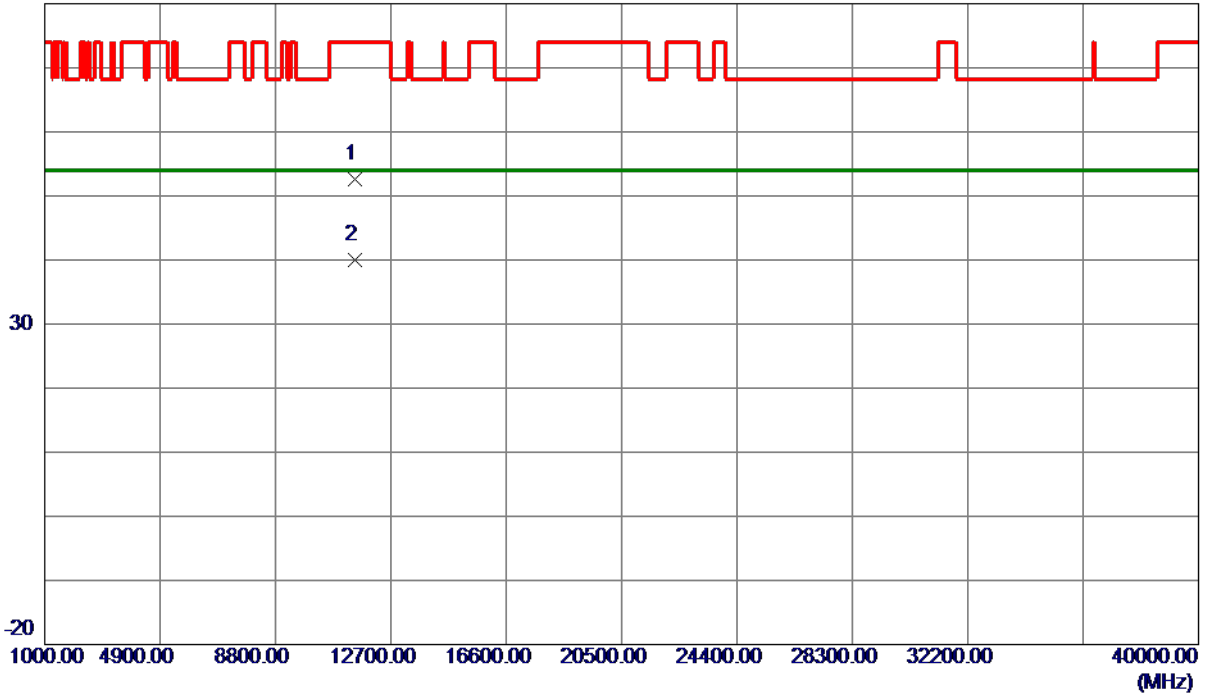

No.	Freq. MHz	Reading Level dBuV/m	Correct Factor dB	Measure ment dBuV/m	Limit dBuV/m	Margin dB	Detector	Comment
1	11490.8350	39.43	13.15	52.58	74.00	-21.42	Peak	
2 *	11491.5350	26.83	13.15	39.98	54.00	-14.02	AVG	

REMARKS:

- (1) Measurement Value = Reading Level + Correct Factor.
- (2) Margin Level = Measurement Value - Limit Value.

Orthogonal Axis	X
Test Mode	UNII-3_TX AC (VHT20) Mode 5785 MHz

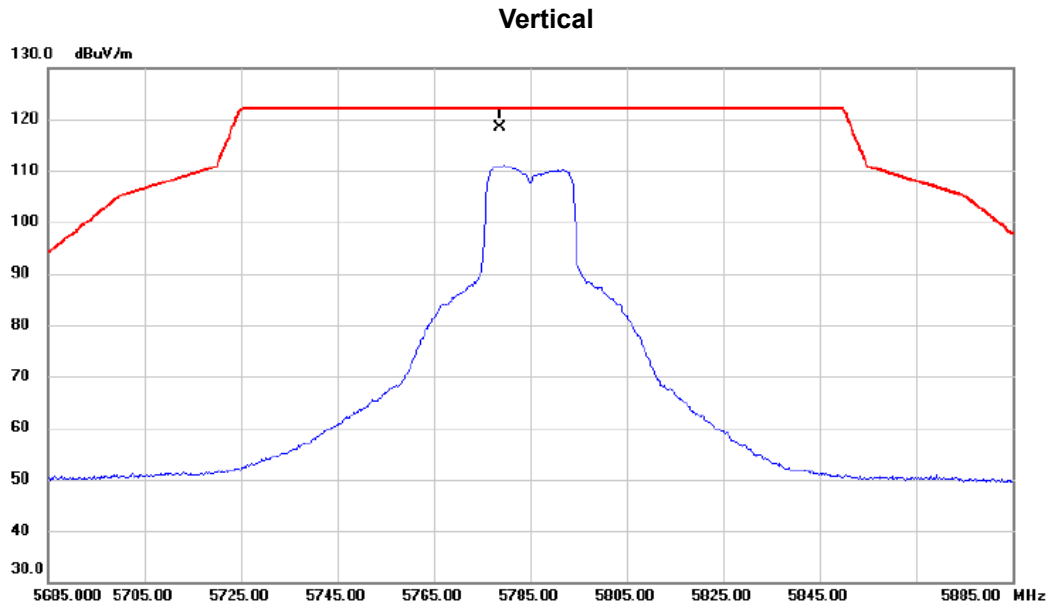

No. Mk.	Freq. MHz	Reading Level dBuV	Correct Factor dB	Measure- ment dBuV/m	Limit dBuV/m	Margin dB	Detector	Comment
1 *	5778.800	101.75	16.61	118.36	122.20	-3.84	peak	No Limit

REMARKS:

- (1) Measurement Value = Reading Level + Correct Factor.
- (2) Margin Level = Measurement Value - Limit Value.

Orthogonal Axis	X
Test Mode	UNII-3_TX AC (VHT20) Mode 5785 MHz

Vertical

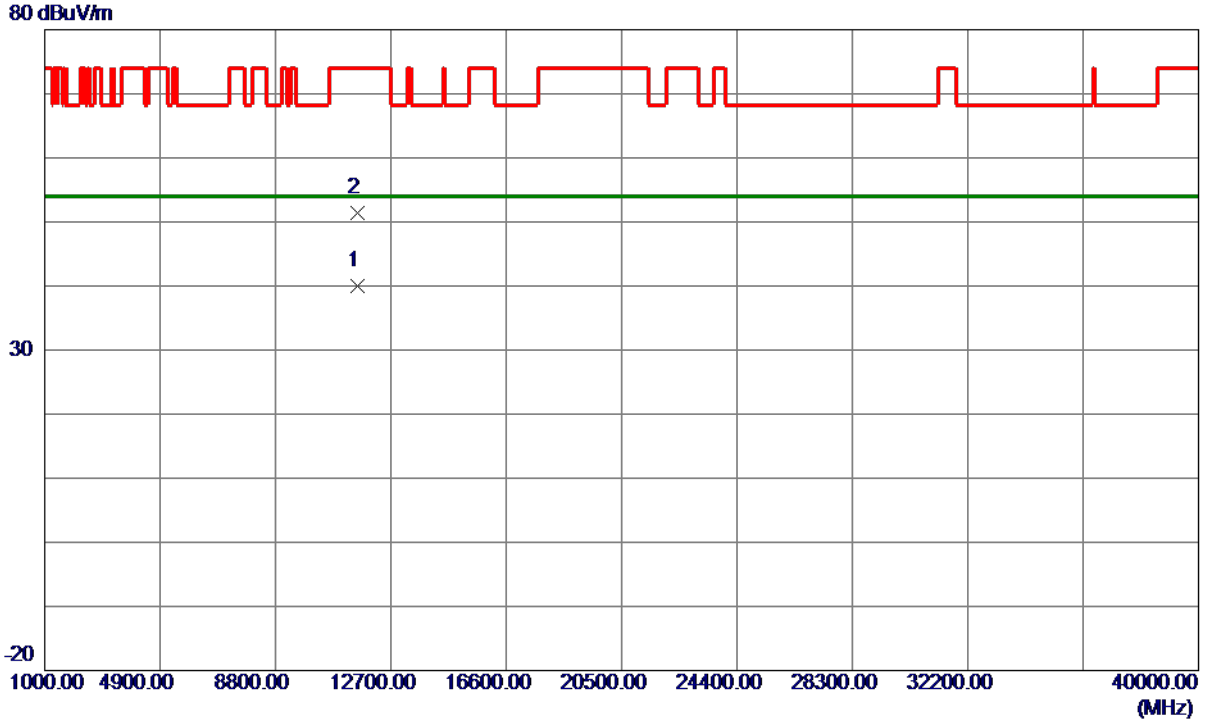

No.	Freq. MHz	Reading Level dBuV/m	Correct Factor dB	Measurement dBuV/m	Limit dBuV/m	Margin dB	Detector	Comment
1 *	11571.5900	26.86	13.20	40.06	54.00	-13.94	AVG	
2	11571.6400	38.14	13.20	51.34	74.00	-22.66	Peak	

REMARKS:

- (1) Measurement Value = Reading Level + Correct Factor.
- (2) Margin Level = Measurement Value - Limit Value.

Orthogonal Axis	X
Test Mode	UNII-3_TX AC (VHT20) Mode 5785 MHz

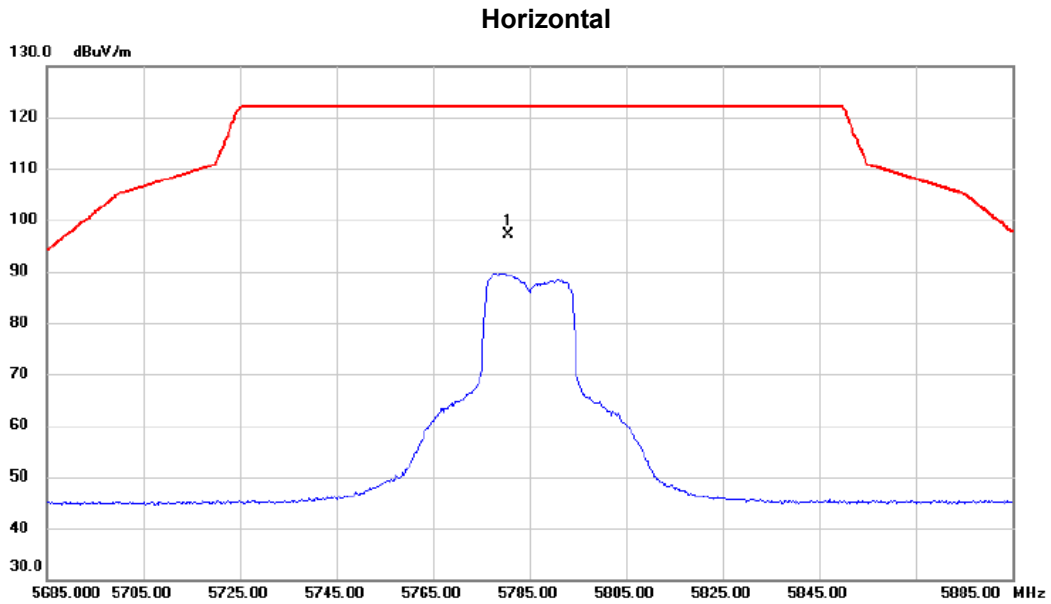

No.	Mk.	Freq.	Reading Level	Correct Factor	Measurement	Limit	Margin	Detector	Comment
		MHz	dBuV	dB	dBuV/m	dBuV/m	dB		
1	*	5780.600	80.50	16.62	97.12	122.20	-25.08	peak	No Limit

REMARKS:

- (1) Measurement Value = Reading Level + Correct Factor.
- (2) Margin Level = Measurement Value - Limit Value.

Orthogonal Axis	X
Test Mode	UNII-3_TX AC (VHT20) Mode 5785 MHz

Horizontal

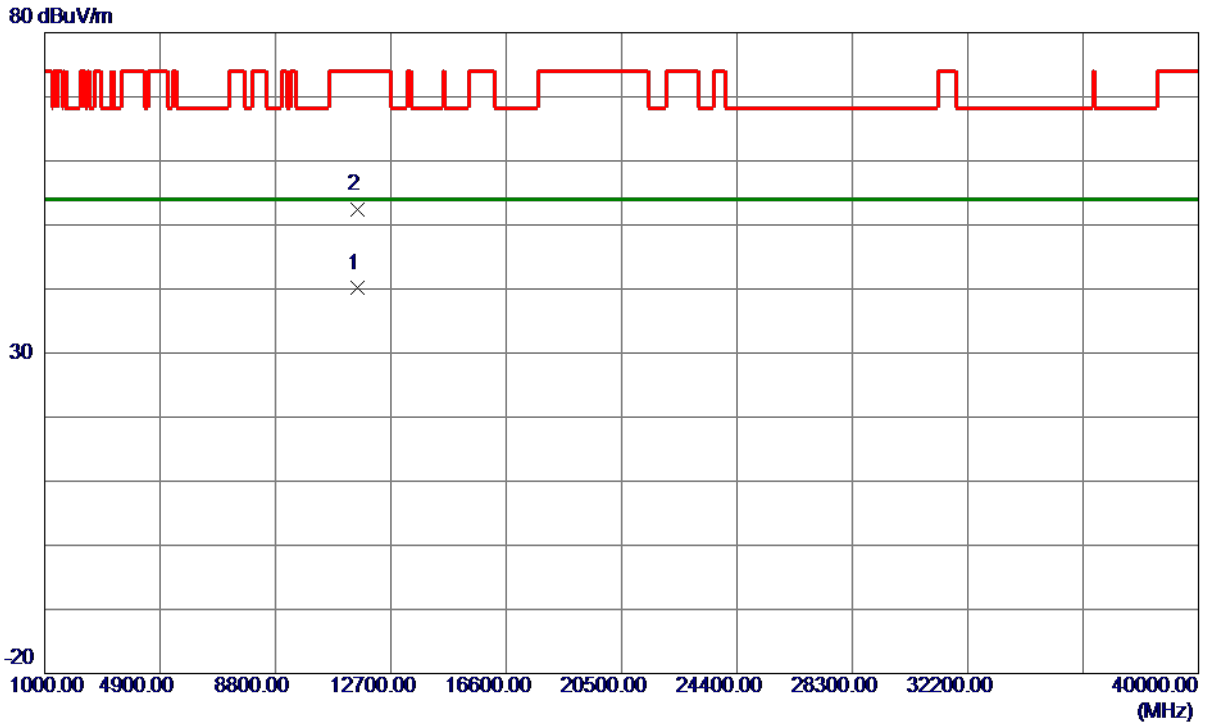

No.	Freq. MHz	Reading Level dBuV/m	Correct Factor dB	Measure ment dBuV/m	Limit dBuV/m	Margin dB	Detector	Comment
1 *	11568.4950	26.90	13.20	40.10	54.00	-13.90	AVG	
2	11570.6000	39.22	13.20	52.42	74.00	-21.58	Peak	

REMARKS:

- (1) Measurement Value = Reading Level + Correct Factor.
- (2) Margin Level = Measurement Value - Limit Value.

Orthogonal Axis	X
Test Mode	UNII-3_TX AC (VHT20) Mode 5825 MHz

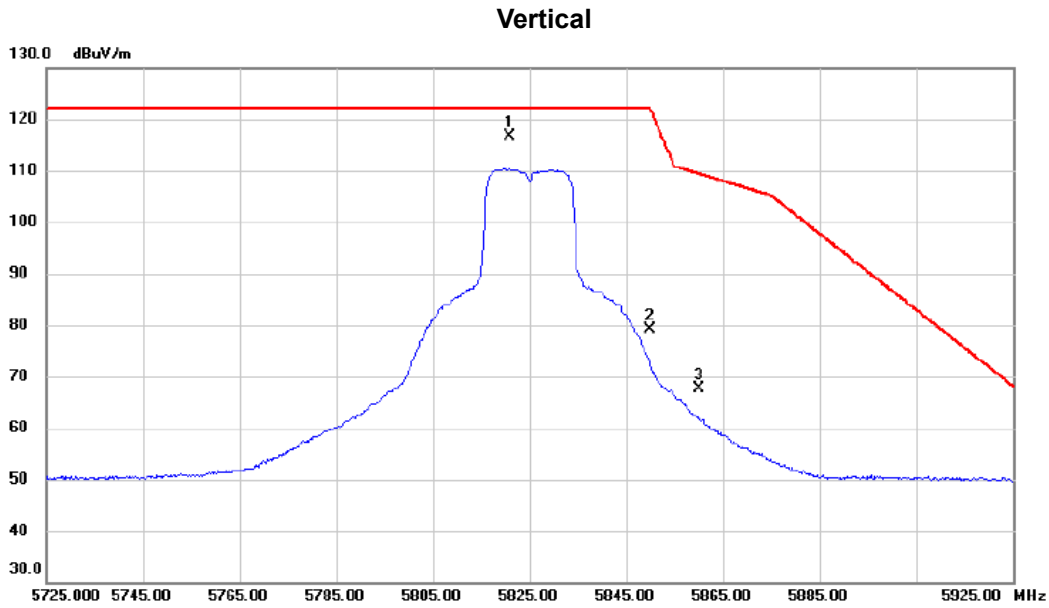

No.	Mk.	Freq. MHz	Reading Level dBuV	Correct Factor dB	Measure- ment dBuV/m	Limit dBuV/m	Margin dB	Detector	Comment
1	*	5820.900	99.95	16.70	116.65	122.20	-5.55	peak	No Limit
2		5850.000	62.31	16.76	79.07	122.20	-43.13	peak	
3		5860.000	50.87	16.79	67.66	109.40	-41.74	peak	

REMARKS:

- (1) Measurement Value = Reading Level + Correct Factor.
- (2) Margin Level = Measurement Value - Limit Value.

Orthogonal Axis	X
Test Mode	UNII-3_TX AC (VHT20) Mode 5825 MHz

Vertical

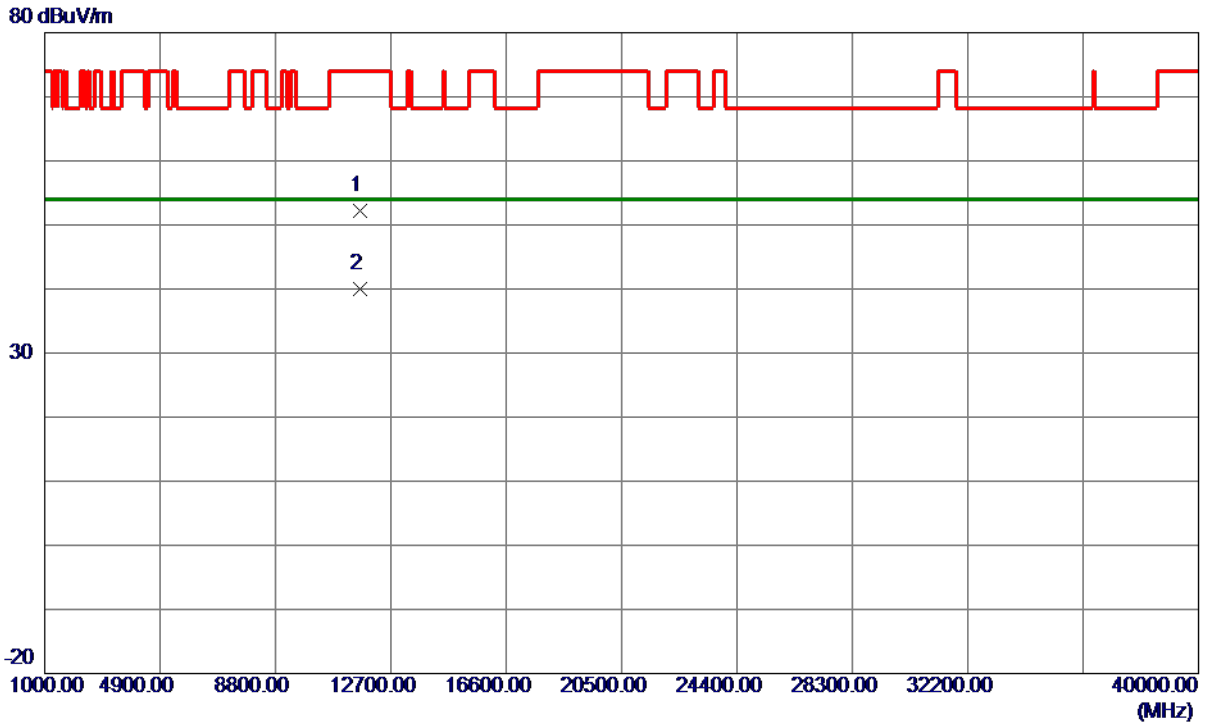

No.	Freq. MHz	Reading Level dBuV/m	Correct Factor dB	Measure ment dBuV/m	Limit dBuV/m	Margin dB	Detector	Comment
1	11647.8550	38.86	13.25	52.11	74.00	-21.89	Peak	
2 *	11648.6750	26.84	13.25	40.09	54.00	-13.91	AVG	

REMARKS:

- (1) Measurement Value = Reading Level + Correct Factor.
- (2) Margin Level = Measurement Value - Limit Value.