

RF MEASUREMENT REPORT

FCC ID: 2AXJ4RE650V2
Applicant: TP-Link Corporation Limited
Application Type: Certification
Product: AC2600 MU-MIMO Wi-Fi Range Extender
Model No.: RE650
Brand Name: tp-link
FCC Classification: Digital Transmission System (DTS)
FCC Rule Part(s): Part 15 Subpart C (Section 15.247)
Test Date: September 17 ~ October 25, 2021

Reviewed By:

Kevin Guo

Approved By:

Robin Wu



The test results relate only to the samples tested.

This equipment has been shown to be capable of compliance with the applicable technical standards as indicated in the measurement report and was tested in accordance with the measurement procedures specified in ANSI C63.10-2013. Test results reported herein relate only to the item(s) tested.

The test report shall not be reproduced except in full without the written approval of MRT Technology (Suzhou) Co., Ltd.

Revision History

Report No.	Version	Description	Issue Date	Note
2109RSU016-U1	Rev. 01	Initial Report	11-09-2021	Valid

CONTENTS

Description	Page
1. General Information	5
1.1. Applicant	5
1.2. Manufacturer	5
1.3. Testing Facility	5
1.4. Product Information.....	6
1.5. Radio Specification	6
1.6. Working Frequencies	7
1.7. Antenna Details.....	7
2. Test Configuration	8
2.1. Test Mode.....	8
2.2. Test System Connection Diagram.....	8
2.3. Test System Details	8
2.4. Test Software	9
2.5. Applied Standards.....	9
2.6. Duty Cycle.....	9
2.7. Test Environment Condition	10
3. Antenna Requirements	11
4. Measuring Instrument	12
5. Measurement Uncertainty.....	14
6. Test Result.....	15
6.1. Summary.....	15
6.2. 6dB Bandwidth.....	16
6.2.1. Test Limit	16
6.2.2. Test Procedure used	16
6.2.3. Test Setting	16
6.2.4. Test Setup	16
6.2.5. Test Result	16
6.3. Output Power	17
6.3.1. Test Limit	17
6.3.2. Test Procedure Used	17
6.3.3. Test Setting	17
6.3.4. Test Setup	17
6.3.5. Test Result	17
6.4. Power Spectral Density.....	18
6.4.1. Test Limit	18

6.4.2.	Test Procedure Used	18
6.4.3.	Test Setting	18
6.4.4.	Test Setup	19
6.4.5.	Test Result	19
6.5.	Conducted Band Edge and Out-of-Band Emissions	20
6.5.1.	Test Limit	20
6.5.2.	Test Procedure Used	20
6.5.3.	Test Setting	20
6.5.4.	Test Setup	21
6.5.5.	Test Result	21
6.6.	Radiated Spurious Emission	22
6.6.1.	Test Limit	22
6.6.2.	Test Procedure Used	22
6.6.3.	Test Setting	22
6.6.4.	Test Setup	24
6.6.5.	Test Result	24
6.7.	Radiated Restricted Band Edge	25
6.7.1.	Test Limit	25
6.7.2.	Test Procedure Used	26
6.7.3.	Test Setting	26
6.7.4.	Test Setup	27
6.7.5.	Test Result	27
6.8.	AC Conducted Emissions	28
6.8.1.	Test Limit	28
6.8.2.	Test Setup	28
6.8.3.	Test Result	28
7.	Conclusion	29
	Appendix A – Test Result	30
A.1	6dB Bandwidth Test Result	30
A.2	Output Power Test Result	35
A.3	Power Spectral Density Test Result	37
A.4	Conducted Band Edge and Out-of-Band Emissions Test Result	54
A.5	Radiated Spurious Emission Test Result	71
A.6	Radiated Restricted Band Edge Test Result	77
	Appendix B – Test Setup Photograph	153
	Appendix C – EUT Photograph	154

1. General Information

1.1. Applicant

TP-Link Corporation Limited

Room 901, 9/F. , New East Ocean Centre, 9 Science Museum Road, Tsim Sha Tsui, Kowloon, Hongkong

1.2. Manufacturer

TP-Link Corporation Limited

Room 901, 9/F. , New East Ocean Centre, 9 Science Museum Road, Tsim Sha Tsui, Kowloon, Hongkong

1.3. Testing Facility

<input checked="" type="checkbox"/>	<p>Test Site – MRT Suzhou Laboratory</p> <hr/> <p>Laboratory Location (Suzhou - Wuzhong) D8 Building, No.2 Tian'edang Rd., Wuzhong Economic Development Zone, Suzhou, China</p> <p>Laboratory Location (Suzhou - SIP) 4b Building, Liando U Valley, No.200 Xingpu Rd., Shengpu Town, Suzhou Industrial Park, China</p> <hr/> <p>Laboratory Accreditations</p> <p>A2LA: 3628.01 CNAS: L10551 FCC: CN1166 ISED: CN0001</p> <p>VCCI: <input type="checkbox"/>R-20025 <input type="checkbox"/>G-20034 <input type="checkbox"/>C-20020 <input type="checkbox"/>T-20020 <input type="checkbox"/>R-20141 <input type="checkbox"/>G-20134 <input type="checkbox"/>C-20103 <input type="checkbox"/>T-20104</p>
<input type="checkbox"/>	<p>Test Site – MRT Shenzhen Laboratory</p> <hr/> <p>Laboratory Location (Shenzhen) 1G, Building A, Junxiangda Building, Zhongshanyuan Road West, Nanshan District, Shenzhen, China</p> <hr/> <p>Laboratory Accreditations</p> <p>A2LA: 3628.02 CNAS: L10551 FCC: CN1284 ISED: CN0105</p>
<input type="checkbox"/>	<p>Test Site – MRT Taiwan Laboratory</p> <hr/> <p>Laboratory Location (Taiwan) No. 38, Fuxing 2nd Rd., Guishan Dist., Taoyuan City 333, Taiwan (R.O.C.)</p> <hr/> <p>Laboratory Accreditations</p> <p>TAF: L3261-190725 FCC: 291082, TW3261 ISED: TW3261</p>

1.4. Product Information

Product Name	AC2600 MU-MIMO Wi-Fi Range Extender
Model No.	RE650
Brand Name	tp-link
Wi-Fi Specification	802.11a/b/g/n/ac & VHT
Antenna Information	Refer to section 1.7
EUT Identification No.	20210909Sample#08 (Conducted) 20210909Sample#11 (Radiated & AC conducted emission)
Power Supply	AC100~240V/50~60Hz
Remark: The information of EUT was provided by the manufacturer, and the accuracy of the information shall be the responsibility of the manufacturer.	

1.5. Radio Specification

Frequency Range	802.11b/g/n-HT20 & VHT20: 2412 ~ 2462MHz 802.11n-HT40 & VHT40: 2422 ~ 2452MHz
Channel Number	802.11b/g/n-HT20 & VHT20: 11 802.11n-HT40 & VHT40: 7
Type of Modulation	802.11b: DSSS 802.11g/n & VHT: OFDM
Data Rate	802.11b: 1/2/5.5/11Mbps 802.11g: 6/9/12/18/24/36/48/54Mbps 802.11n: up to 600Mbps VHT: up to 800Mbps

Note: For other features of this EUT, test report will be issued separately.

1.6. Working Frequencies

802.11b/g/n-HT20 & VHT20

Channel	Frequency	Channel	Frequency	Channel	Frequency
01	2412 MHz	02	2417 MHz	03	2422 MHz
04	2427 MHz	05	2432 MHz	06	2437 MHz
07	2442 MHz	08	2447 MHz	09	2452 MHz
10	2457 MHz	11	2462 MHz	--	--

802.11n-HT40 & VH40

Channel	Frequency	Channel	Frequency	Channel	Frequency
03	2422 MHz	04	2427 MHz	05	2432 MHz
06	2437 MHz	07	2442 MHz	08	2447 MHz
09	2452 MHz	--	--	--	--

1.7. Antenna Details

Antenna Type	Frequency Band (MHz)	Tx Paths	Max Antenna Gain (dBi)	Beamforming Directional Gain (dBi)	CDD Directional Gain (dBi)	
					For Power	For PSD
Dipole Antenna	2412 ~ 2462	4	1.0	7.02	1.0	7.02
	5150 ~ 5850	4	2.0	8.02	2.0	8.02

Remark:

- The EUT supports Cyclic Delay Diversity (CDD) mode, and CDD signals are correlated.
If all antennas have the same gain, G_{ANT} , Directional gain = $G_{ANT} + \text{Array Gain}$, where Array Gain is as follows.
 - For power spectral density (PSD) measurements on all devices,
Array Gain = $10 \log (N_{ANT} / N_{SS})$ dB;
 - For power measurements on IEEE 802.11 devices,
Array Gain = 0 dB for $N_{ANT} \leq 4$;
- The EUT also supports Beam Forming mode, and the Beam Forming support 802.11n/ac & VHT, not include 802.11a/b/g. BF Directional gain = $G_{ANT} + 10 \log (N_{ANT})$.

2. Test Configuration

2.1. Test Mode

Mode 1: Transmit by 802.11b (1Mbps) (CDD mode)
Mode 2: Transmit by 802.11g (6Mbps) (CDD mode)
Mode 3: Transmit by VHT20 (MCS0) (CDD mode)
Mode 4: Transmit by VHT40 (MCS0) (CDD mode)
Mode 5: Transmit by VHT20 (MCS0) (Beamforming mode)
Mode 6: Transmit by VHT40 (MCS0) (Beamforming mode)

Note 1: Due to the same modulation between 802.11n and VHT, so 802.11n-HT20 and HT40 are covered by VHT20 and VHT40 in this report, meanwhile, power setting for 802.11n-HT20 and HT40 will not be greater than VHT20 and VHT40.

Note 2: Due to CDD mode was the worst mode, so all test items were evaluated in this report. The beamforming mode only evaluated the RF output power.

2.2. Test System Connection Diagram

The device was tested per the guidance ANSI C63.10: 2013 was used to reference the appropriate EUT setup for radiated emissions testing and AC line conducted testing.

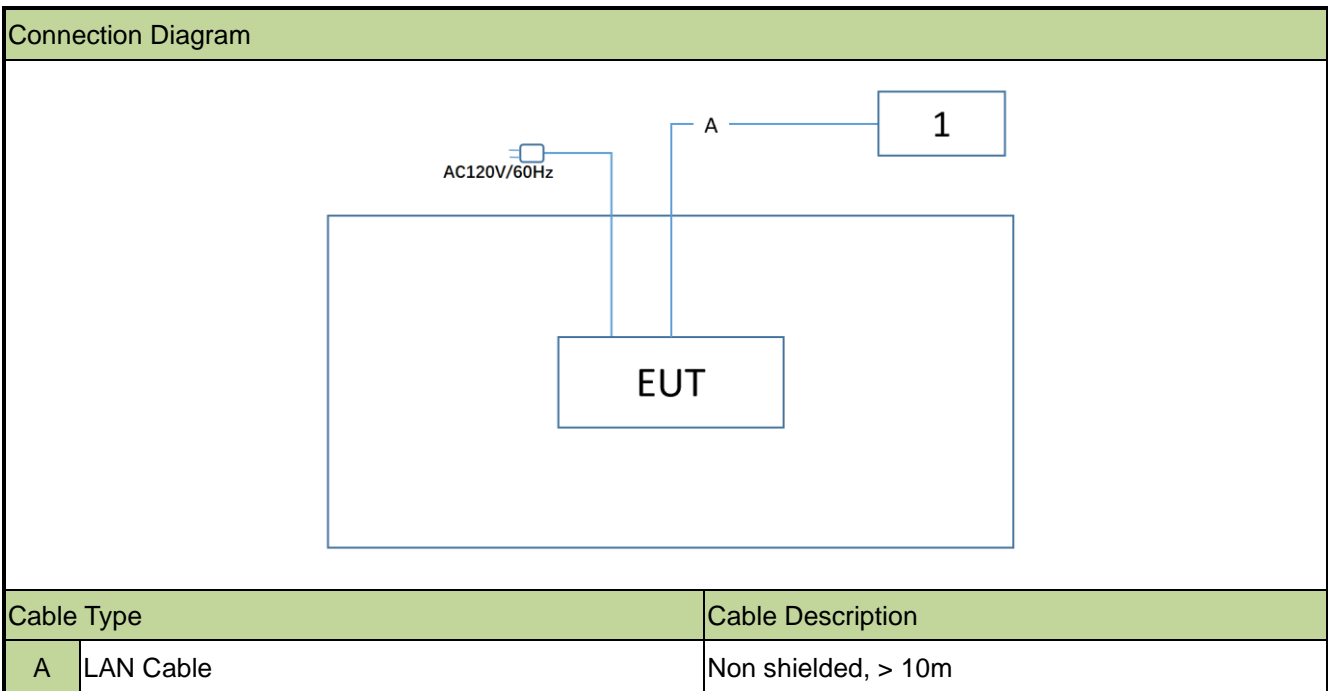

2.3. Test System Details

Product	Manufacturer	Model No.
1 Notebook	Lenovo	X230

2.4. Test Software

The test utility software used during testing was “QATool_Dbg.exe”, and the version was 0.0.0.70.

Note: Detail power setting refer to operational description.

2.5. Applied Standards

According to the specifications of the manufacturer, the EUT must comply with the requirements of the following standards:

- FCC Part 15.247
- KDB 558074 D01v05r02
- KDB 662911 D01v02r01
- ANSI C63.10-2013

2.6. Duty Cycle

The maximum achievable duty cycles for all modes were determined based on measurements performed on a spectrum analyzer in zero-span mode with RBW = 8MHz, VBW = 50MHz. The RBW and VBW were both greater than 50/T, where T is the minimum transmission duration, and the number of sweep points across T was greater than 100. The duty cycles are as follows:

Test Mode	Duty Cycle
802.11b	79.46%
802.11g	98.07%
VHT20	98.16%
VHT40	93.54%
Duty Cycle (T = Transmission Duration)	
802.11b (T = 32.10ms)	802.11g (T = 2.689ms)

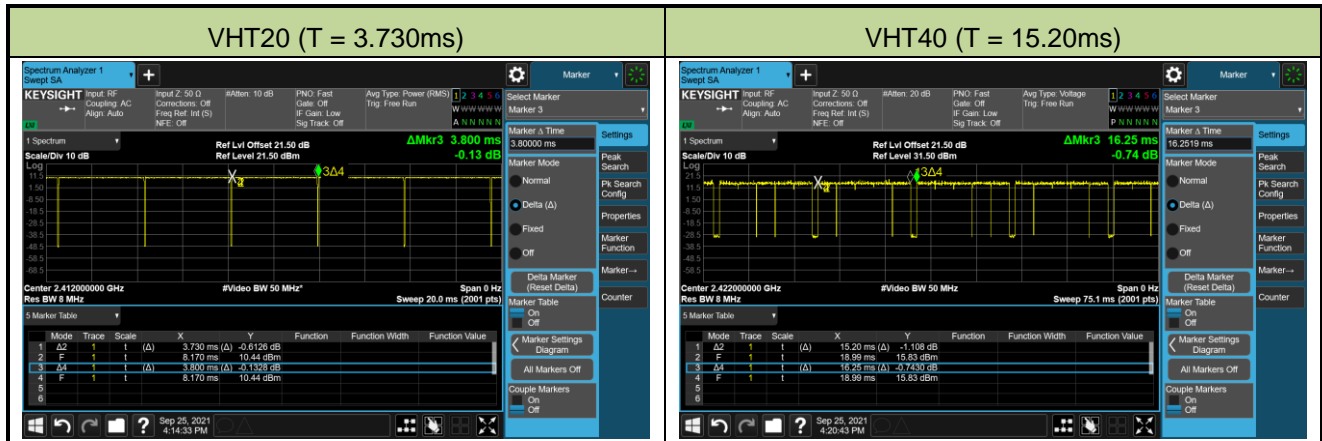

2.7. Test Environment Condition

Ambient Temperature	15 ~ 35°C
Relative Humidity	20%RH ~75%RH

3. Antenna Requirements

Excerpt from §15.203 of the FCC Rules/Regulations:

“An intentional radiator antenna shall be designed to ensure that no antenna other than that furnished by the responsible party can be used with the device. The use of a permanently attached antenna or of an antenna that uses a unique coupling to the intentional radiator shall be considered sufficient to comply with the provisions of this section.”

- The antenna of the device is **permanently attached**.
- There are no provisions for connection to an external antenna.

Conclusion:

The unit complies with the requirement of §15.203.

4. Measuring Instrument

No.	Instrument	Manufacturer	Model No.	Asset No.	Last Cali. Date	Cali. Due Date	Test Site
1	Signal Analyzer	Agilent	N9020A	MRTSUE06106	1 year	2022/4/13	WZ-SR5
2	Thermohygrometer	testo	608-H1	MRTSUE06402	1 year	2022/6/28	WZ-SR5
3	Shielding Room	HUAMING	WZ-SR5	MRTSUE06442	/	/	WZ-SR5
4	Signal Analyzer	Keysight	N9010B	MRTSUE06457	1 year	2022/6/24	WZ-SR5
5	USB Power Sensor	Agilent	U2021XA	MRTSUE06030	1 year	2022/10/10	WZ-SR3/WZ-SR5
6	USB Power Sensor	Boonton	55006	MRTSUE06109	1 year	2022/4/13	WZ-SR3/WZ-SR5
7	USB Power Sensor	Keysight	U2021XA	MRTSUE06446	1 year	2022/6/8	WZ-SR3/WZ-SR5
8	USB Power Sensor	Keysight	U2021XA	MRTSUE06447	1 year	2022/6/8	WZ-SR3/WZ-SR5
9	USB Power Sensor	Keysight	U2021XA	MRTSUE06582	1 year	2022/8/8	WZ-SR3/WZ-SR5
10	Two-Line V-Network	R&S	ENV216	MRTSUE06002	1 year	2022/6/8	WZ-SR2
11	CDN	Teseq	ISN PLT-A	MRTSUE06007	1 year	2022/3/1	WZ-SR2
12	Shielding Room	MIX-BEP	WZ-SR2	MRTSUE06215	/	/	WZ-SR2
13	Thermohygrometer	testo	608-H1	MRTSUE06404	1 year	2022/6/28	WZ-SR2
14	Four-Line V-Network	R&S	ENV432	MRTSUE06615	1 year	2022/10/10	WZ-SR2
15	EMI Test Receiver	R&S	ESR3	MRTSUE06909	1 year	2021/11/22	WZ-SR2
16	Loop Antenna	Schwarzbeck	FMZB 1519	MRTSUE06025	1 year	2021/11/8	WZ-AC1/WZ-AC2
17	Horn Antenna	Schwarzbeck	BBHA 9170	MRTSUE06597	1 year	2021/12/14	WZ-AC1/WZ-AC2
18	Preamplifier	EMCI	EMC184045SE	MRTSUE06640	1 year	2022/1/14	WZ-AC1/WZ-AC2
19	Preamplifier	EMCI	EMC051845SE	MRTSUE06987	1 year	2022/9/9	WZ-AC1/WZ-AC2
20	EMI Test Receiver	R&S	ESR7	MRTSUE06001	1 year	2022/1/4	WZ-AC1
21	Horn Antenna	Schwarzbeck	BBHA 9120D	MRTSUE06023	1 year	2022/9/16	WZ-AC1
22	Preamplifier	Agilent	83017A	MRTSUE06076	1 year	2021/11/14	WZ-AC1
23	TRILOG Antenna	Schwarzbeck	VULB 9168	MRTSUE06172	1 year	2022/8/5	WZ-AC1
24	Thermohygrometer	Yuhuaze	HTC-2	MRTSUE06184	1 year	2022/8/10	WZ-AC1
25	Anechoic Chamber	TDK	WZ-AC1	MRTSUE06212	1 year	2022/4/29	WZ-AC1
26	Thermohygrometer	testo	608-H1	MRTSUE06403	1 year	2022/6/28	WZ-AC1

No.	Instrument	Manufacturer	Model No.	Asset No.	Last Cali. Date	Cali. Due Date	Test Site
27	Signal Analyzer	Keysight	N9010B	MRTSUE06607	1 year	2022/1/6	WZ-AC1
28	Horn Antenna	Schwarzbeck	BBHA 9170	MRTSUE06599	1 year	2021/11/26	SIP-AC2
29	Preamplifier	EMCI	EMC184045SE	MRTSUE06602	1 year	2022/10/11	SIP-AC2
30	Thermohygrometer	testo	608-H1	MRTSUE06623	1 year	2021/12/3	SIP-AC2
31	Thermohygrometer	testo	608-H1	MRTSUE06624	1 year	2021/12/3	SIP-AC2
32	Preamplifier	EMCI	EMC051845SE	MRTSUE06644	1 year	2021/11/9	SIP-AC2
33	TRILOG Antenna	Schwarzbeck	VULB 9168	MRTSUE06647	1 year	2022/8/5	SIP-AC2
34	Anechoic Chamber	RIKEN	SIP-AC2	MRTSUE06781	1 year	2021/12/24	SIP-AC2
35	Signal Analyzer	Keysight	N9010B	MRTSUE06559	1 year	2022/6/24	SIP-AC1/SIP-AC2/SIP-AC3/SIP-SR1
36	Signal Analyzer	Keysight	N9010B	MRTSUE06603	1 year	2021/11/23	SIP-AC1/SIP-AC2/SIP-AC3/SIP-SR1
37	Signal Analyzer	Keysight	N9020B	MRTSUE06604	1 year	2022/9/7	SIP-AC1/SIP-AC2/SIP-AC3/SIP-SR1
38	EMI Test Receiver	R&S	ESR3	MRTSUE06185	1 year	2022/1/12	SIP-AC1/SIP-AC2/SIP-AC3
39	EMI Test Receiver	R&S	ESR3	MRTSUE06613	1 year	2022/6/24	SIP-AC1/SIP-AC2/SIP-AC3
40	Preamplifier	EMCI	EMC001330	MRTSUE06643	1 year	2022/1/14	SIP-AC1/SIP-AC2/SIP-AC3
41	Loop Antenna	Schwarzbeck	FMZB 1519 B	MRTSUE06937	1 year	2022/3/9	SIP-AC1/SIP-AC2/SIP-AC3

Software	Version	Function
EMI Software	V3	EMI Test Software

5. Measurement Uncertainty

Where relevant, the following test uncertainty levels have been estimated for tests performed on the EUT as specified in CISPR 16-4-2. This uncertainty represents an expanded uncertainty expressed at approximately the 95% confidence level using a coverage factor of $k = 2$.

AC Conducted Emission Measurement
Measurement Uncertainty for a Level of Confidence of 95% ($U=2Uc(y)$): 9kHz~150kHz: 3.74dB 150kHz~30MHz: 3.44dB
Radiated Disturbance
Measurement Uncertainty for a Level of Confidence of 95% ($U=2Uc(y)$): Horizontal: 30MHz~300MHz: 5.04dB 300MHz~1GHz: 4.95dB 1GHz~40GHz: 6.40dB Vertical: 30MHz~300MHz: 5.24dB 300MHz~1GHz: 6.03dB 1GHz~40GHz: 6.40dB
Spurious Emissions, Conducted
Measuring Uncertainty for a Level of Confidence of 95% ($U=2Uc(y)$): 0.78dB
Output Power
Measuring Uncertainty for a Level of Confidence of 95% ($U=2Uc(y)$): 1.13dB
Power Spectrum Density
Measuring Uncertainty for a Level of Confidence of 95% ($U=2Uc(y)$): 1.15dB
Occupied Bandwidth
Measuring Uncertainty for a Level of Confidence of 95% ($U=2Uc(y)$): 0.28%

6. Test Result

6.1. Summary

FCC Section(s)	Test Description	Test Condition	Verdict
15.247(a)(2)	6dB Bandwidth	Conducted	Pass
15.247(b)(3)	Output Power		Pass
15.247(e)	Power Spectral Density		Pass
15.247(d)	Band Edge / Out-of-Band Emissions		Pass
15.205 15.209	General Field Strength (Restricted Bands and Radiated Emission)	Radiated	Pass
15.207	AC Conducted Emissions 150kHz - 30MHz	Line Conducted	Pass

Remark:

1. The analyzer plots shown in this section were all taken with a correction table loaded into the analyzer. The correction table was used to account for the losses of the cables and attenuators used as part of the system to connect the EUT to the analyzer at all frequencies of interest.
2. Output power test was verified over all data rates of each mode (data refers to operational description), and then choose the maximum power output (low data rate) for the final test of each channel.
3. For radiated emission tests, every axis (X, Y, Z) was also verified. The test results shown in the following sections represent the worst-case emissions.

6.2. 6dB Bandwidth

6.2.1. Test Limit

The minimum 6dB bandwidth shall be at least 500 kHz.

6.2.2. Test Procedure used

ANSI C63.10 - 2013 - Section 11.8

6.2.3. Test Setting

1. The Spectrum's automatic bandwidth measurement capability was used to perform the 6dB bandwidth measurement. The "X" dB bandwidth parameter was set to $X = 6$. The bandwidth measurement was not influenced by any intermediate power nulls in the fundamental emission.
2. Set RBW = 100 kHz
3. VBW $\geq 3 \times$ RBW
4. Detector = Peak
5. Trace mode = Max hold
6. Sweep = Auto couple
7. Allow the trace to stabilize

6.2.4. Test Setup

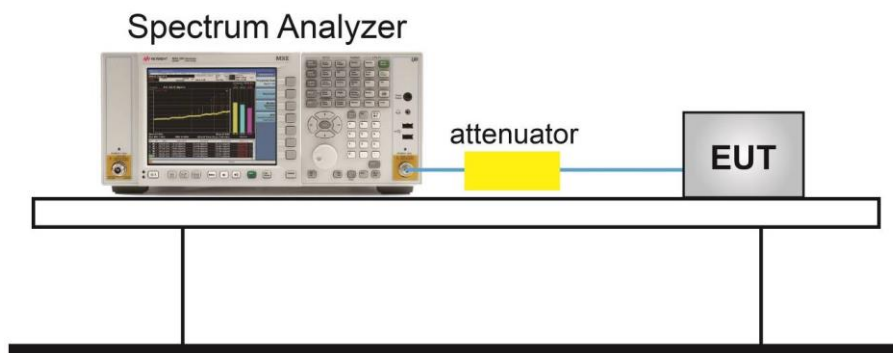

6.2.5. Test Result

Refer to Appendix A.1.

6.3. Output Power

6.3.1. Test Limit

The maximum output power shall be less 1 Watt (30dBm).

The conducted output power limit specified in paragraph FCC Part 15.247(b) of this section is based on the use of antennas with directional gains that do not exceed 6 dBi. If transmitting antennas of directional gain greater than 6 dBi are used, the conducted output power from the intentional radiator shall be reduced below the stated values in paragraphs FCC Part 15.247(b)(3) of this section, as appropriate, by the amount in dB that the directional gain of the antenna exceeds 6 dBi.

6.3.2. Test Procedure Used

ANSI C63.10 - 2013 - Section 11.9.2.3.2

6.3.3. Test Setting

Average Power Measurement

Average power measurements were performed only when the EUT was transmitting at its maximum power control level using a broadband power meter with a pulse sensor. The power meter implemented triggering and gating capabilities which were set up such that power measurements were recorded only during the ON time of the transmitter.

6.3.4. Test Setup

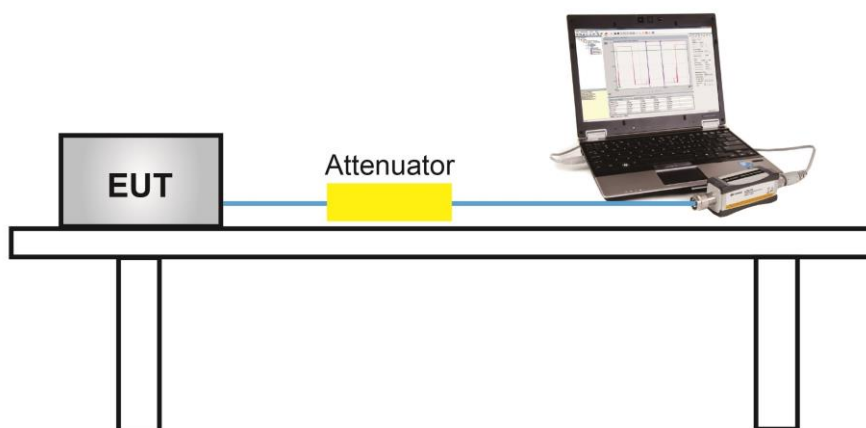

6.3.5. Test Result

Refer to Appendix A.2.

6.4. Power Spectral Density

6.4.1. Test Limit

The maximum permissible power spectral density is 8dBm in any 3 kHz band.

The same method of determining the conducted output power shall be used to determine the power spectral density.

6.4.2. Test Procedure Used

ANSI C63.10 - 2013 - Section 11.10.5

6.4.3. Test Setting

1. Measure the duty cycle (x) of the transmitter output signal.
2. Set instrument center frequency to DTS channel center frequency.
3. Set span to at least 1.5 times the OBW.
4. RBW = 10 kHz.
5. VBW = 30 kHz.
6. Detector = RMS.
7. Ensure that the number of measurement points in the sweep $\geq 2 \times \text{span}/\text{RBW}$.
8. Sweep time = auto couple.
9. Don't use sweep triggering. Allow sweep to "free run".
10. Employ trace averaging (RMS) mode over a minimum of 100 traces.
11. Use the peak marker function to determine the maximum amplitude level.
12. Add $10 \log (1/x)$, where x is the duty cycle measured in step (a), to the measured PSD to compute the average PSD during the actual transmission time. If measured value exceeds requirement specified by regulatory agency, then reduce RBW (but no less than 3 kHz) and repeat (note that this may require zooming in on the emission of interest and reducing the span to meet the minimum measurement point requirement as the RBW is reduced).

6.4.4. Test Setup

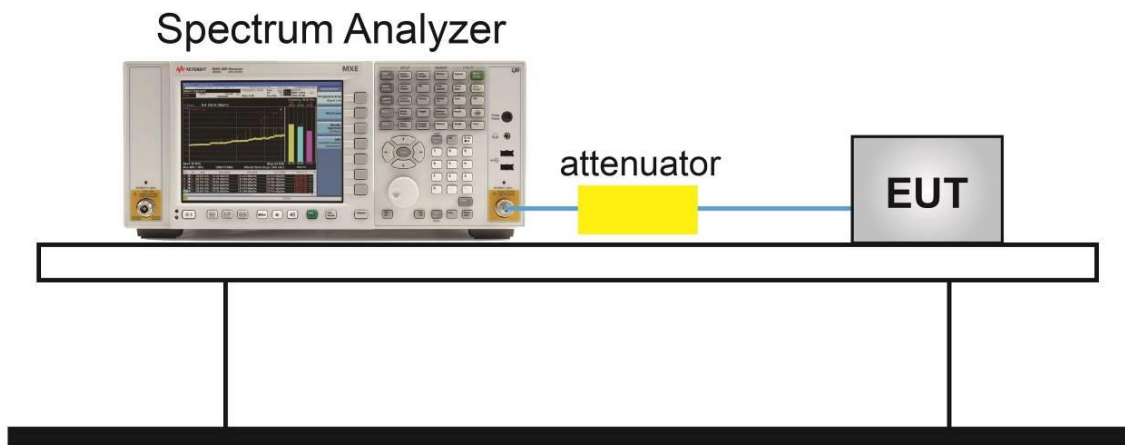

6.4.5. Test Result

Refer to Appendix A.3.

6.5. Conducted Band Edge and Out-of-Band Emissions

6.5.1. Test Limit

The limit for out-of-band spurious emissions at the band edge is 30dB below the fundamental emission level, as determined from the in-band power measurement of the DTS channel performed in a 100 kHz bandwidth per the PSD procedure.

6.5.2. Test Procedure Used

ANSI C63.10-2013 - Section 11.11

6.5.3. Test Setting

Reference level measurement

1. Set instrument center frequency to DTS channel center frequency
2. Set the span to ≥ 1.5 times the DTS bandwidth
3. Set the RBW = 100 kHz
4. Set the VBW $\geq 3 \times$ RBW
5. Detector = peak
6. Sweep time = auto couple
7. Trace mode = max hold
8. Allow trace to fully stabilize

Emission level measurement

1. Set the center frequency and span to encompass frequency range to be measured
2. RBW = 100kHz
3. VBW = 300kHz
4. Detector = Peak
5. Trace mode = max hold
6. Sweep time = auto couple
7. The trace was allowed to stabilize

6.5.4. Test Setup

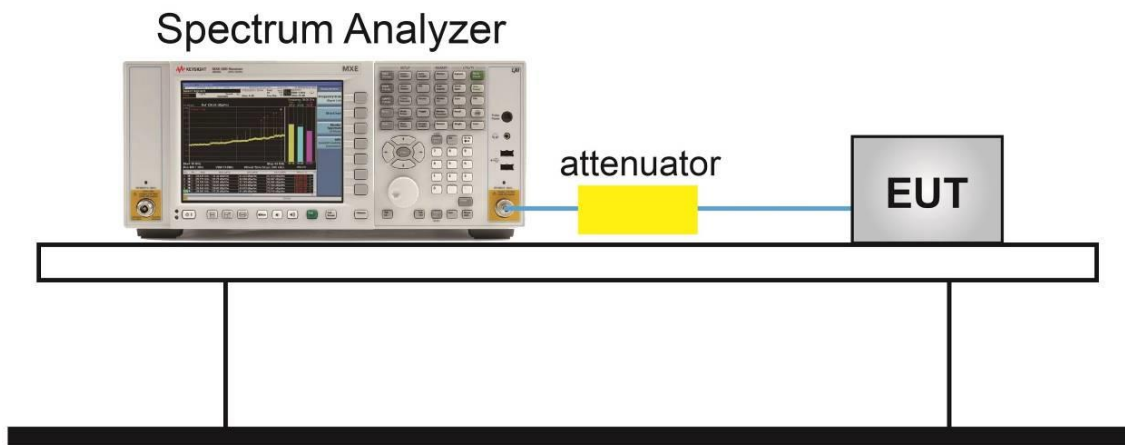

6.5.5. Test Result

Refer to Appendix A.4.

6.6. Radiated Spurious Emission

6.6.1. Test Limit

All out of band emissions appearing in a restricted band as specified in Section 15.205 of the Title 47 CFR must not exceed the limits shown in Table per Section 15.209.

FCC Part 15 Subpart C Paragraph 15.209		
Frequency [MHz]	Field Strength [uV/m]	Measured Distance [Meters]
0.009 - 0.490	2400/F (kHz)	300
0.490 - 1.705	24000/F (kHz)	30
1.705 - 30	30	30
30 - 88	100	3
88 - 216	150	3
216 - 960	200	3
Above 960	500	3

6.6.2. Test Procedure Used

ANSI C63.10 - 2013 - Section 11.11 & 11.12

ANSI C63.10 - 2013 - Section 6.3 (General Requirements)

ANSI C63.10 - 2013 - Section 6.4 (Standard test method below 30MHz)

ANSI C63.10 - 2013 - Section 6.5 (Standard test method above 30MHz to 1GHz)

ANSI C63.10 - 2013 - Section 6.6 (Standard test method above 1GHz)

6.6.3. Test Setting

Table 1 - RBW as a function of frequency

Frequency	RBW
9 ~ 150 kHz	200 ~ 300 Hz
0.15 ~ 30 MHz	9 ~ 10 kHz
30 ~ 1000 MHz	100 ~ 120 kHz
> 1000MHz	1MHz

Quasi-Peak Measurements below 1GHz

1. Analyzer center frequency was set to the frequency of the radiated spurious emission of interest
2. Span was set greater than 1MHz
3. RBW = as specified in Table 1
4. Detector = CISPR quasi-peak
5. Sweep time = auto couple
6. Trace was allowed to stabilize

Peak Measurements above 1GHz

1. Analyzer center frequency was set to the frequency of the radiated spurious emission of interest
2. RBW = 1MHz
3. VBW = 3MHz
4. Detector = peak
5. Sweep time = auto couple
6. Trace mode = max hold
7. Trace was allowed to stabilize

Average Measurements above 1GHz (Method VB)

1. Analyzer center frequency was set to the frequency of the radiated spurious emission of interest
2. RBW = 1MHz
3. VBW; If the EUT is configured to transmit with duty cycle $\geq 98\%$, set VBW = 10 Hz.
If the EUT duty cycle is $< 98\%$, set VBW $\geq 1/T$. T is the minimum transmission duration.
4. Detector = Peak
5. Sweep time = auto
6. Trace mode = max hold
7. Trace was allowed to stabilize

6.6.4. Test Setup

Below 1GHz Test Setup:

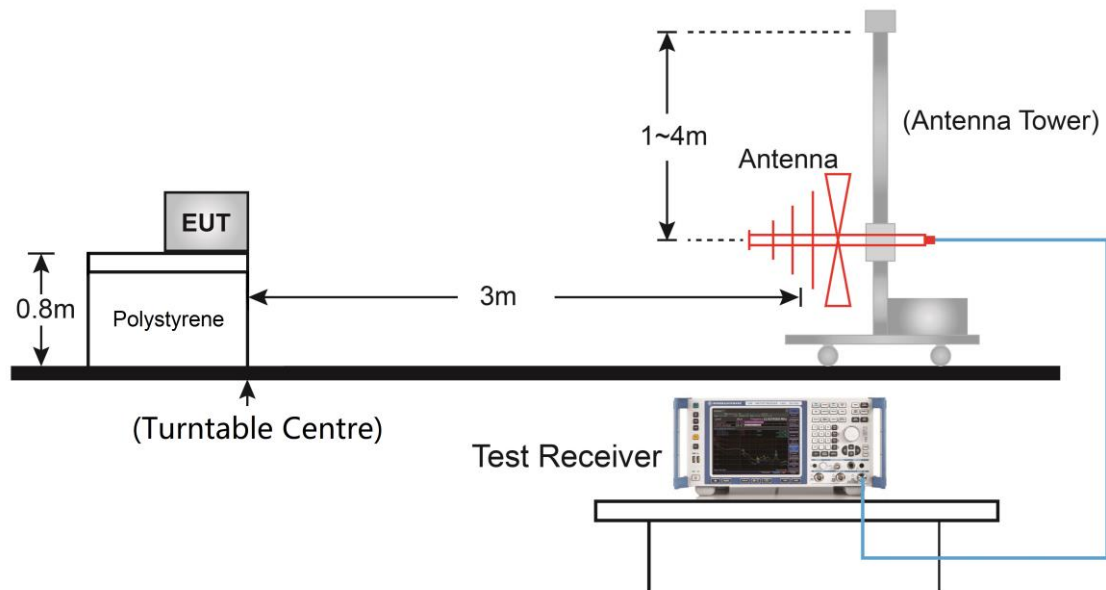

Above 1GHz Test Setup:

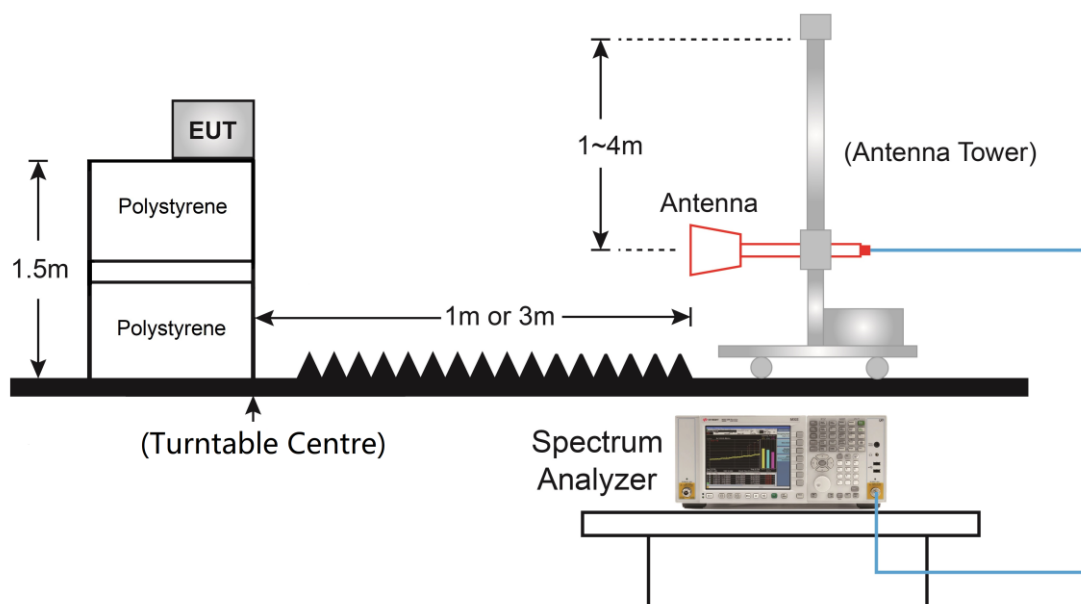

6.6.5. Test Result

Refer to Appendix A.5.

6.7. Radiated Restricted Band Edge

6.7.1. Test Limit

For 15.205 requirement:

Radiated emissions which fall in the restricted bands, as defined in Section 15.205(a) of FCC part 15, must also comply with the radiated emission limits specified in Section 15.209(a).

Frequency (MHz)	Frequency (MHz)	Frequency (MHz)	Frequency (GHz)
0.090 - 0.110	16.42 - 16.423	399.9 - 410	4.5 - 5.15
¹ 0.495 - 0.505	16.69475 - 16.69525	608 - 614	5.35 - 5.46
2.1735 - 2.1905	16.80425 - 16.80475	960 - 1240	7.25 - 7.75
4.125 - 4.128	25.5 - 25.67	1300 - 1427	8.025 - 8.5
4.17725 - 4.17775	37.5 - 38.25	1435 - 1626.5	9.0 - 9.2
4.20725 - 4.20775	73 - 74.6	1645.5 - 1646.5	9.3 - 9.5
6.215 - 6.218	74.8 - 75.2	1660 - 1710	10.6 - 12.7
6.26775 - 6.26825	108 - 121.94	1718.8 - 1722.2	13.25 - 13.4
6.31175 - 6.31225	123 - 138	2200 - 2300	14.47 - 14.5
8.291 - 8.294	149.9 - 150.05	2310 - 2390	15.35 - 16.2
8.362 - 8.366	156.52475 - 156.52525	2483.5 - 2500	17.7 - 21.4
8.37625 - 8.38675	156.7 - 156.9	2690 - 2900	22.01 - 23.12
8.41425 - 8.41475	162.0125 - 167.17	3260 - 3267	23.6 - 24.0
12.29 - 12.293	167.72 - 173.2	3332 - 3339	31.2 - 31.8
12.51975 - 12.52025	240 - 285	3345.8 - 3358	36.43 - 36.5
12.57675 - 12.57725	322 - 335.4	3600 - 4400	(²)
13.36 - 13.41	--	--	--

All out of band emissions appearing in a restricted band as specified in Section 15.205 of the Title 47CFR must not exceed the limits shown in Table per Section 15.209.

FCC Part 15 Subpart C Paragraph 15.209		
Frequency [MHz]	Field Strength [uV/m]	Measured Distance [Meters]
0.009 - 0.490	2400/F (kHz)	300
0.490 - 1.705	24000/F (kHz)	30
1.705 - 30	30	30
30 - 88	100	3
88 - 216	150	3
216 - 960	200	3
Above 960	500	3

6.7.2. Test Procedure Used

ANSI C63.10-2013 Section 6.3

ANSI C63.10-2013 Section 6.6

ANSI C63.10-2013 Section 11.13

6.7.3. Test Setting

Peak Field Strength Measurements

1. Analyzer center frequency was set to the frequency of the radiated spurious emission of interest
2. RBW = 1MHz
3. VBW = 3MHz
4. Detector = peak
5. Sweep time = auto couple
6. Trace mode = max hold
7. Trace was allowed to stabilize

Average Field Strength Measurements

1. Analyzer center frequency was set to the frequency of the radiated spurious emission of interest
2. RBW = 1MHz
3. VBW $\geq 1/T$
4. As an alternative, the instrument may be set to linear detector mode. Ensure that video filtering is applied in linear voltage domain (rather than in a log or dB domain). Some instruments require linear display mode in order to accomplish this. Others have a setting for Average-VBW Type, which can be set to "Voltage" regardless of the display mode
5. Detector = Peak
6. Sweep time = auto
7. Trace mode = max hold
8. Allow max hold to run for at least 50 times (1/duty cycle) traces

6.7.4. Test Setup

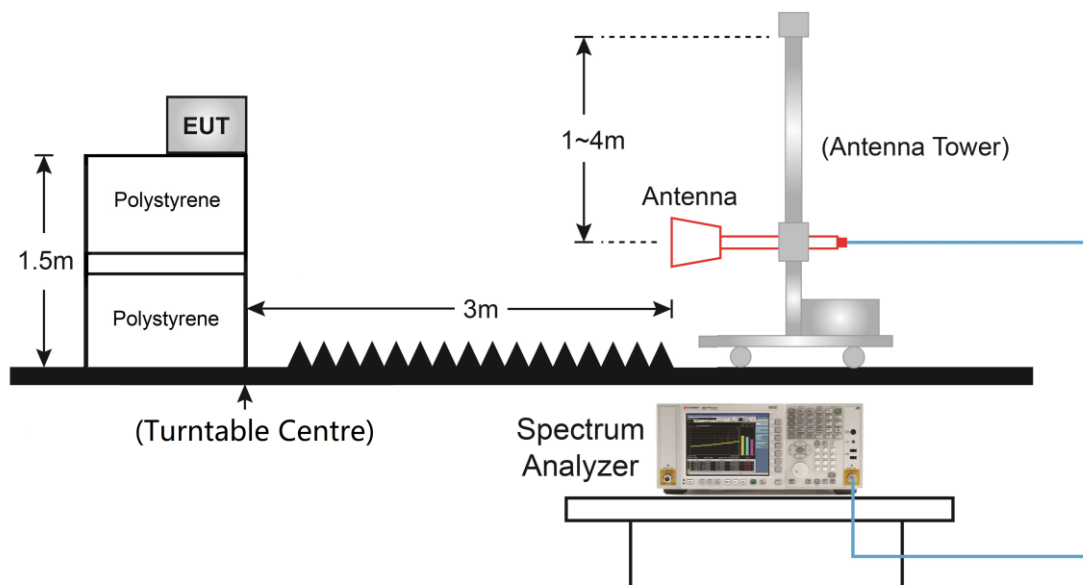

6.7.5. Test Result

Refer to Appendix A.6.

6.8. AC Conducted Emissions

6.8.1. Test Limit

FCC Part 15 Subpart C Paragraph 15.207 Limits		
Frequency (MHz)	QP (dBuV)	AV (dBuV)
0.15 - 0.50	66 - 56	56 - 46
0.50 - 5.0	56	46
5.0 - 30	60	50

Note 1: The lower limit shall apply at the transition frequencies.

Note 2: The limit decreases linearly with the logarithm of the frequency in the range 0.15MHz to 0.5MHz.

6.8.2. Test Setup

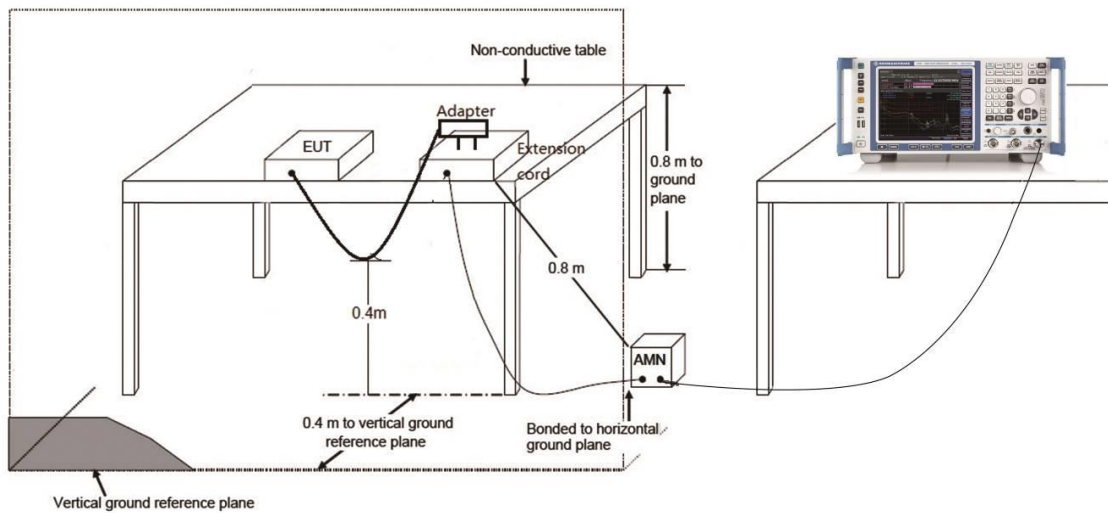

6.8.3. Test Result

Refer to Appendix A.7.

7. Conclusion

The data collected relate only the item(s) tested and show that the device is in compliance with Part 15C of the FCC rules.

Appendix A – Test Result

A.1 6dB Bandwidth Test Result

Test Site	WZ-SR5	Test Engineer	Luis Yang
Test Date	2021/09/23~2021/10/25		

Test Mode	Data Rate / MCS	Channel No.	Frequency (MHz)	6dB Bandwidth (MHz)	Limit (MHz)
11b	11Mbps	01	2412	9.08	≥ 0.5
11b	11Mbps	06	2437	10.09	≥ 0.5
11b	11Mbps	11	2462	9.09	≥ 0.5
11g	6Mbps	01	2412	15.12	≥ 0.5
11g	6Mbps	06	2437	15.14	≥ 0.5
11g	6Mbps	11	2462	15.13	≥ 0.5
VHT20	MCS0	01	2412	15.10	≥ 0.5
VHT20	MCS0	06	2437	15.13	≥ 0.5
VHT20	MCS0	11	2462	14.99	≥ 0.5
VHT40	MCS0	03	2422	35.11	≥ 0.5
VHT40	MCS0	06	2437	33.86	≥ 0.5
VHT40	MCS0	09	2452	35.06	≥ 0.5

802.11b 6dB Bandwidth

Channel 01 (2412MHz)

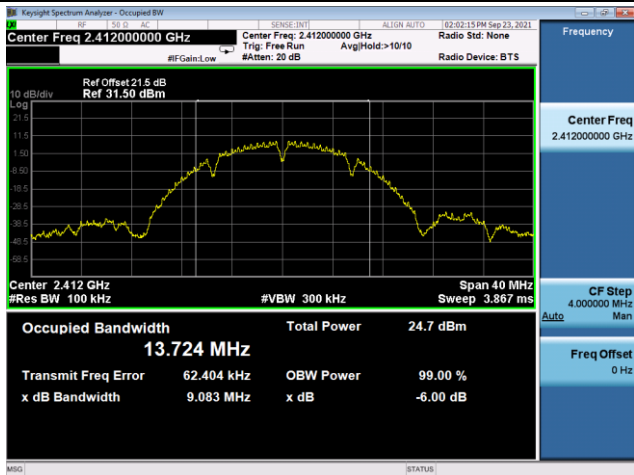

Channel 06 (2437MHz)

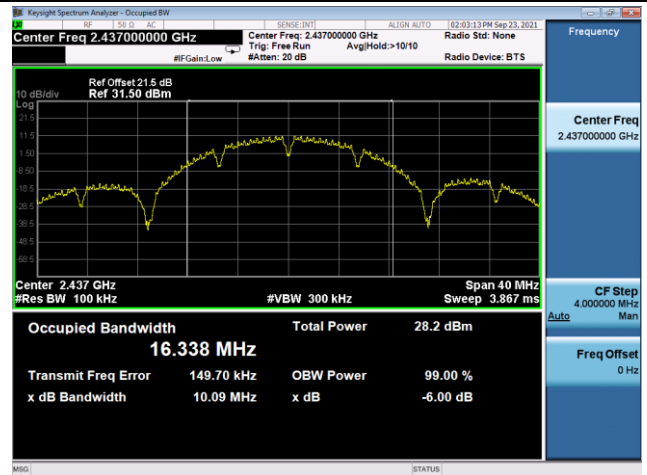

Channel 11 (2462MHz)

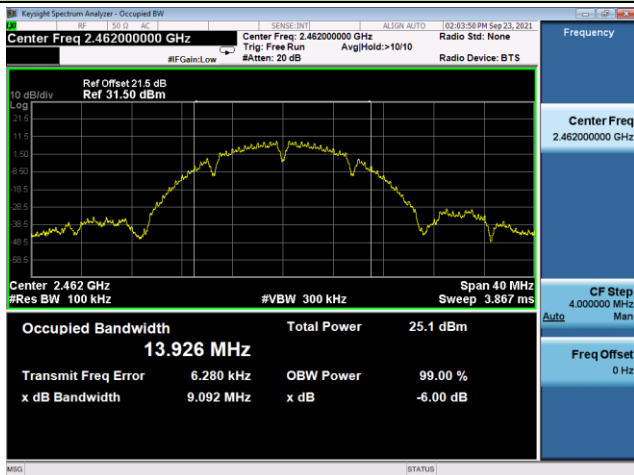

802.11g 6dB Bandwidth

Channel 01 (2412MHz)

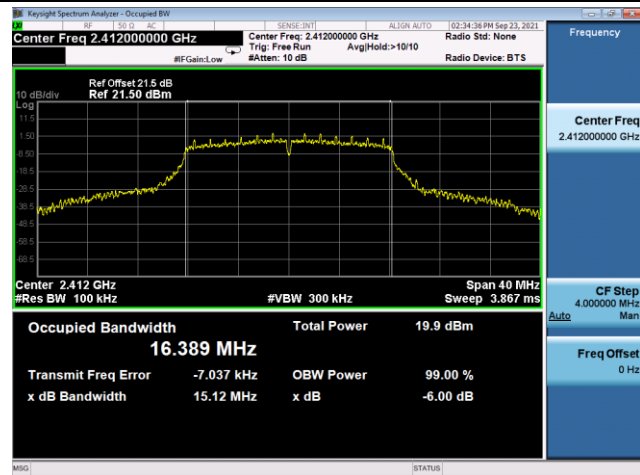

Channel 06 (2437MHz)

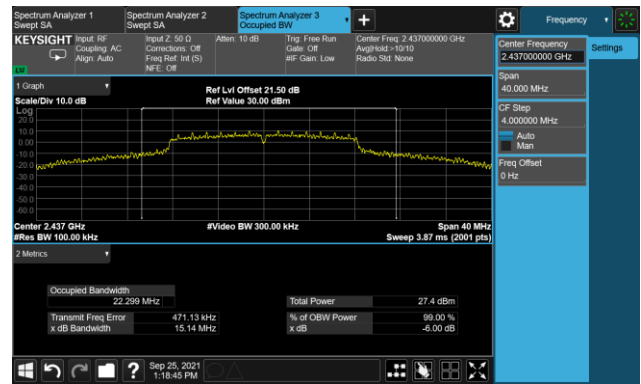

Channel 11 (2462MHz)

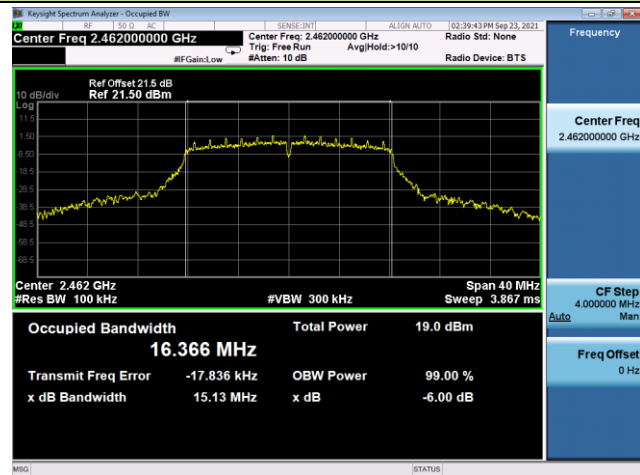

VHT20 6dB Bandwidth

Channel 01 (2412MHz)

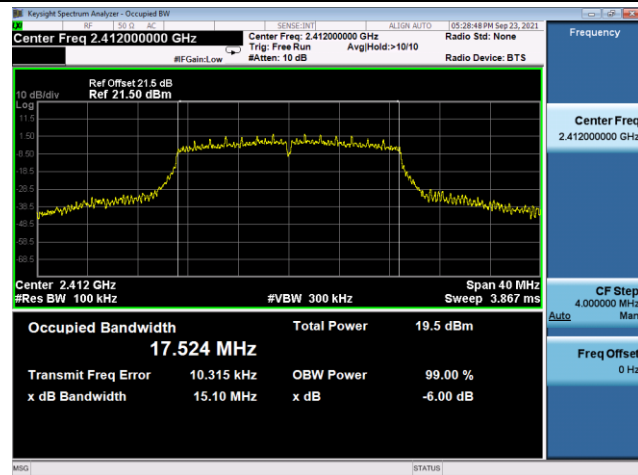

Channel 06 (2437MHz)

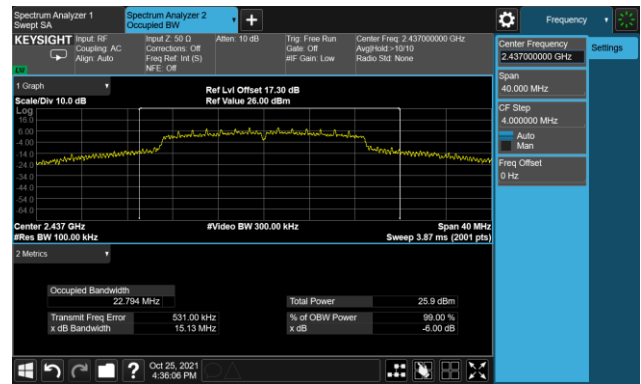

Channel 11 (2462MHz)

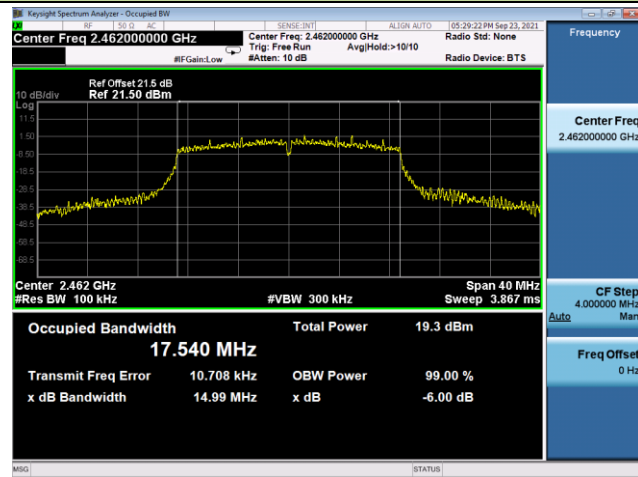

VHT40 6dB Bandwidth

Channel 03 (2422MHz)

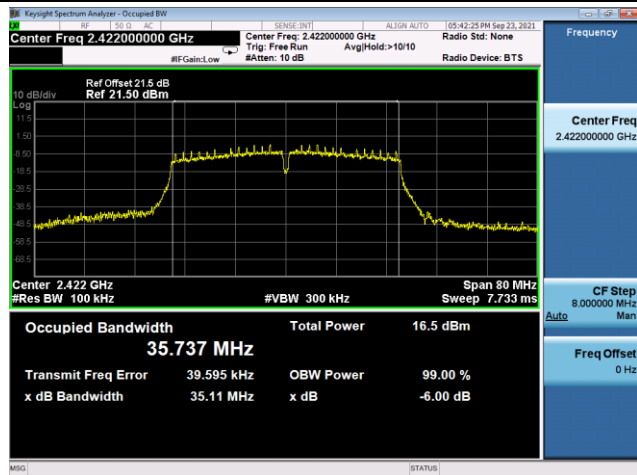

Channel 06 (2437MHz)

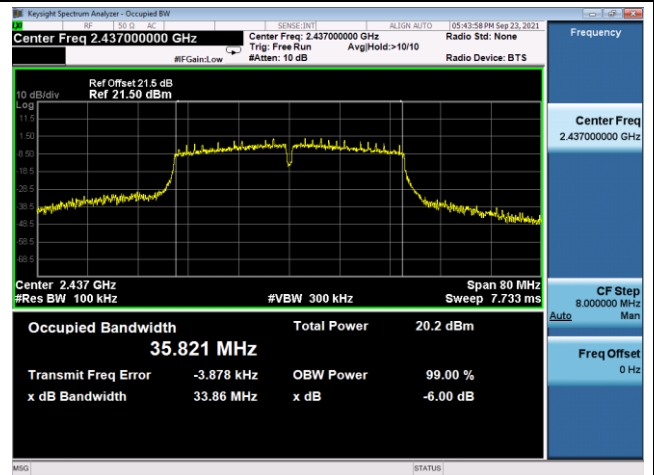

Channel 09 (2452MHz)

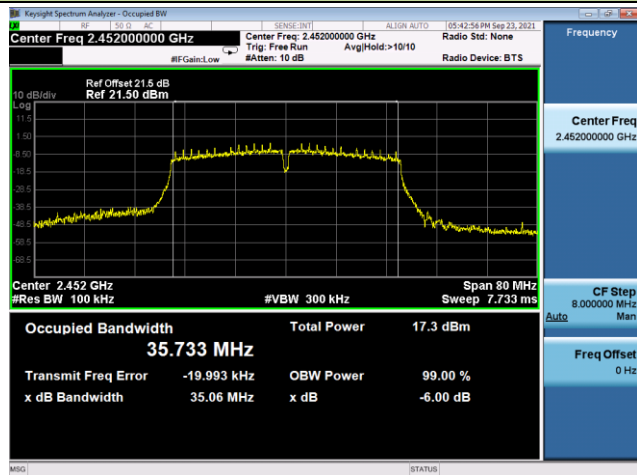

A.2 Output Power Test Result

Test Site	WZ-SR5	Test Engineer	Luis Yang
Test Date	2021/09/21~2021/10/25	Test Mode	CDD Mode

Test Mode	Data Rate/ MCS	Channel No.	Freq. (MHz)	Average Power (dBm)				Total Average Power (dBm)	Limit (dBm)
				Ant 0	Ant 1	Ant 2	Ant 3		
11b	11Mbps	01	2412	17.93	18.59	18.89	17.98	24.39	≤ 30.00
11b	11Mbps	02	2417	18.77	19.76	20.26	19.36	25.59	≤ 30.00
11b	11Mbps	06	2437	21.36	21.48	21.62	21.71	27.57	≤ 30.00
11b	11Mbps	09	2452	18.48	20.12	20.14	19.37	25.60	≤ 30.00
11b	11Mbps	10	2457	17.03	18.70	18.72	17.75	24.13	≤ 30.00
11b	11Mbps	11	2462	18.05	18.78	17.89	18.46	24.33	≤ 30.00
11g	6Mbps	01	2412	13.57	14.58	14.95	14.49	20.45	≤ 30.00
11g	6Mbps	02	2417	15.90	16.92	17.34	16.80	22.79	≤ 30.00
11g	6Mbps	03	2422	17.67	18.89	19.15	18.71	24.66	≤ 30.00
11g	6Mbps	06	2437	19.42	20.34	20.89	20.17	26.26	≤ 30.00
11g	6Mbps	08	2447	19.12	20.81	20.93	20.24	26.35	≤ 30.00
11g	6Mbps	09	2452	15.94	17.27	17.41	16.73	22.90	≤ 30.00
11g	6Mbps	10	2457	15.86	17.38	17.52	16.68	22.93	≤ 30.00
11g	6Mbps	11	2462	13.72	14.29	15.17	14.33	20.43	≤ 30.00
VHT20	MCS0	01	2412	12.61	13.95	13.26	13.83	19.46	≤ 30.00
VHT20	MCS0	02	2417	15.82	17.53	17.78	17.35	23.20	≤ 30.00
VHT20	MCS0	06	2437	19.61	20.46	19.86	18.28	25.64	≤ 30.00
VHT20	MCS0	08	2447	16.26	17.54	17.91	17.27	23.31	≤ 30.00
VHT20	MCS0	09	2452	15.79	17.02	17.47	16.78	22.83	≤ 30.00
VHT20	MCS0	10	2457	14.47	16.24	16.53	15.79	21.85	≤ 30.00
VHT20	MCS0	11	2462	13.09	14.41	13.99	14.36	20.01	≤ 30.00
VHT40	MCS0	03	2422	10.13	10.46	11.18	10.94	16.72	≤ 30.00
VHT40	MCS0	04	2427	10.40	11.39	11.98	11.57	17.39	≤ 30.00
VHT40	MCS0	06	2437	14.46	14.73	15.55	15.32	21.06	≤ 30.00
VHT40	MCS0	09	2452	11.74	10.95	11.82	10.54	17.32	≤ 30.00

Note: Total Average Power (dBm) = $10 \cdot \log \{10^{(\text{Ant 0 Average Power} / 10)} + 10^{(\text{Ant 1 Average Power} / 10)} + 10^{(\text{Ant 2 Average Power} / 10)} + 10^{(\text{Ant 3 Average Power} / 10)}\}$ (dBm).

Test Site	WZ-SR5	Test Engineer	Luis Yang
Test Date	2021/09/21~2021/10/25		Beamforming Mode

Test Mode	Data Rate/ MCS	Channel No.	Freq. (MHz)	Average Power (dBm)				Total Average Power (dBm)	Limit (dBm)
				Ant 0	Ant 1	Ant 2	Ant 3		
VHT20	MCS0	01	2412	12.61	13.95	13.26	13.83	19.46	≤ 28.98
VHT20	MCS0	02	2417	15.82	17.53	17.78	17.35	23.20	≤ 28.98
VHT20	MCS0	06	2437	19.61	20.46	19.86	18.28	25.64	≤ 28.98
VHT20	MCS0	08	2447	16.26	17.54	17.91	17.27	23.31	≤ 28.98
VHT20	MCS0	09	2452	15.79	17.02	17.47	16.78	22.83	≤ 28.98
VHT20	MCS0	10	2457	14.47	16.24	16.53	15.79	21.85	≤ 28.98
VHT20	MCS0	11	2462	13.09	14.41	13.99	14.36	20.01	≤ 28.98
VHT40	MCS0	03	2422	10.13	10.46	11.18	10.94	16.72	≤ 28.98
VHT40	MCS0	04	2427	10.40	11.39	11.98	11.57	17.39	≤ 28.98
VHT40	MCS0	06	2437	14.46	14.73	15.55	15.32	21.06	≤ 28.98
VHT40	MCS0	09	2452	11.74	10.95	11.82	10.54	17.32	≤ 28.98

Note 1: Total Average Power (dBm) = $10 \cdot \log \{10^{(\text{Ant 0 Average Power} / 10)} + 10^{(\text{Ant 1 Average Power} / 10)} + 10^{(\text{Ant 2 Average Power} / 10)} + 10^{(\text{Ant 3 Average Power} / 10)}\}$ (dBm).

Note 2: Power Limit (dBm) = $30 - (7.02 - 6) = 28.98\text{dBm}$

A.3 Power Spectral Density Test Result

Test Site	WZ-SR5	Test Engineer	Luis Yang
Test Date	2021/09/23~2021/10/25		

Test Mode	Data Rate/ MCS	Channel No.	Freq. (MHz)	AVG PSD (dBm/ 10kHz)				Duty Cycle (%)	Total PSD (dBm/ 10kHz)	Limit (dBm/ 3kHz)
				Ant 0	Ant 1	Ant 2	Ant 3			
11b	11Mbps	01	2412	-9.65	-8.53	-8.44	-10.46	79.46	-2.17	≤ 6.98
11b	11Mbps	06	2437	-5.35	-4.24	-7.06	-7.69	79.46	1.15	≤ 6.98
11b	11Mbps	11	2462	-8.64	-8.48	-7.90	-9.88	79.46	-1.65	≤ 6.98
11g	6Mbps	01	2412	-14.23	-13.39	-12.81	-13.70	98.07	-7.40	≤ 6.98
11g	6Mbps	06	2437	-9.46	-7.91	-8.39	-9.30	98.07	-2.61	≤ 6.98
11g	6Mbps	11	2462	-14.47	-14.01	-12.76	-13.37	98.07	-7.50	≤ 6.98
VHT20	MCS0	01	2412	-14.83	-13.41	-14.65	-14.66	98.16	-8.25	≤ 6.98
VHT20	MCS0	06	2437	-9.85	-8.78	-9.60	-10.02	98.16	-3.43	≤ 6.98
VHT20	MCS0	11	2462	-14.71	-13.13	-12.29	-14.98	98.16	-7.53	≤ 6.98
VHT40	MCS0	03	2422	-21.69	-20.39	-21.18	-20.14	93.54	-14.49	≤ 6.98
VHT40	MCS0	06	2437	-15.58	-16.48	-15.83	-16.59	93.54	-9.79	≤ 6.98
VHT40	MCS0	09	2452	-21.04	-19.11	-18.55	-20.73	93.54	-13.42	≤ 6.98

Note 1:

When EUT duty cycle > 98%, Total AVG PSD = $10 \cdot \log \{10^{(\text{Ant 0 AVG PSD}/10)} + 10^{(\text{Ant 1 AVG PSD}/10)} + 10^{(\text{Ant 2 AVG PSD}/10)} + 10^{(\text{Ant 3 AVG PSD}/10)}\}$

When EUT duty cycle ≤ 98%, Total AVG PSD = $10 \cdot \log \{10^{(\text{Ant 0 AVG PSD}/10)} + 10^{(\text{Ant 1 AVG PSD}/10)} + 10^{(\text{Ant 2 AVG PSD}/10)} + 10^{(\text{Ant 3 AVG PSD}/10)}\} + 10 \cdot \log (1/\text{Duty Cycle})$.

Note 2: PSD Limit (dBm/3KHz) = $8 - (7.02-6) = 6.98\text{dBm}/3\text{KHz}$

Note 3: The power setting of Beamforming mode is not greater than CDD mode, so only CDD mode result was shown in this section.

802.11b AVGPDS -Ant 0

Channel 01 (2412MHz)



Channel 06 (2437MHz)



Channel 11 (2462MHz)



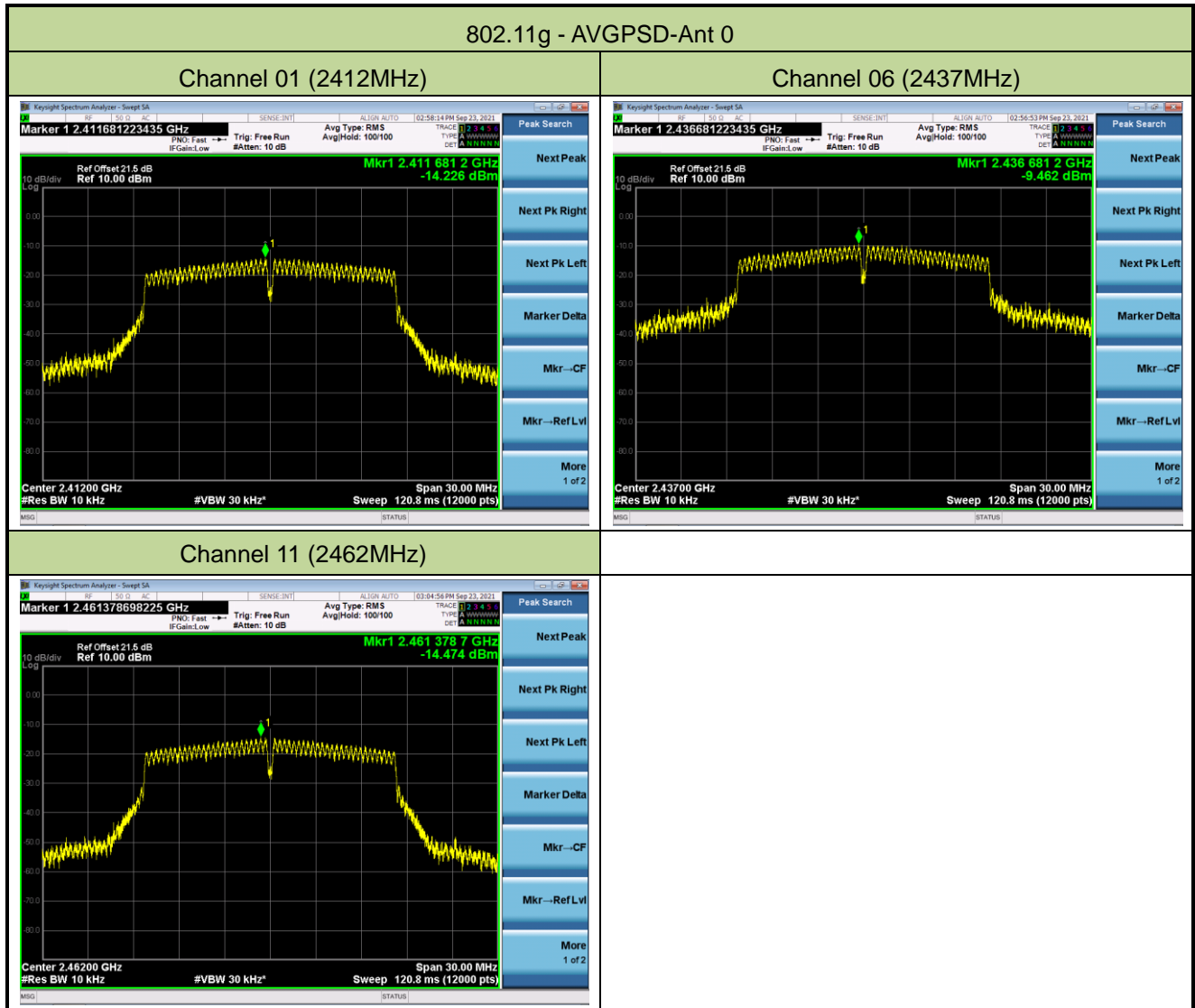

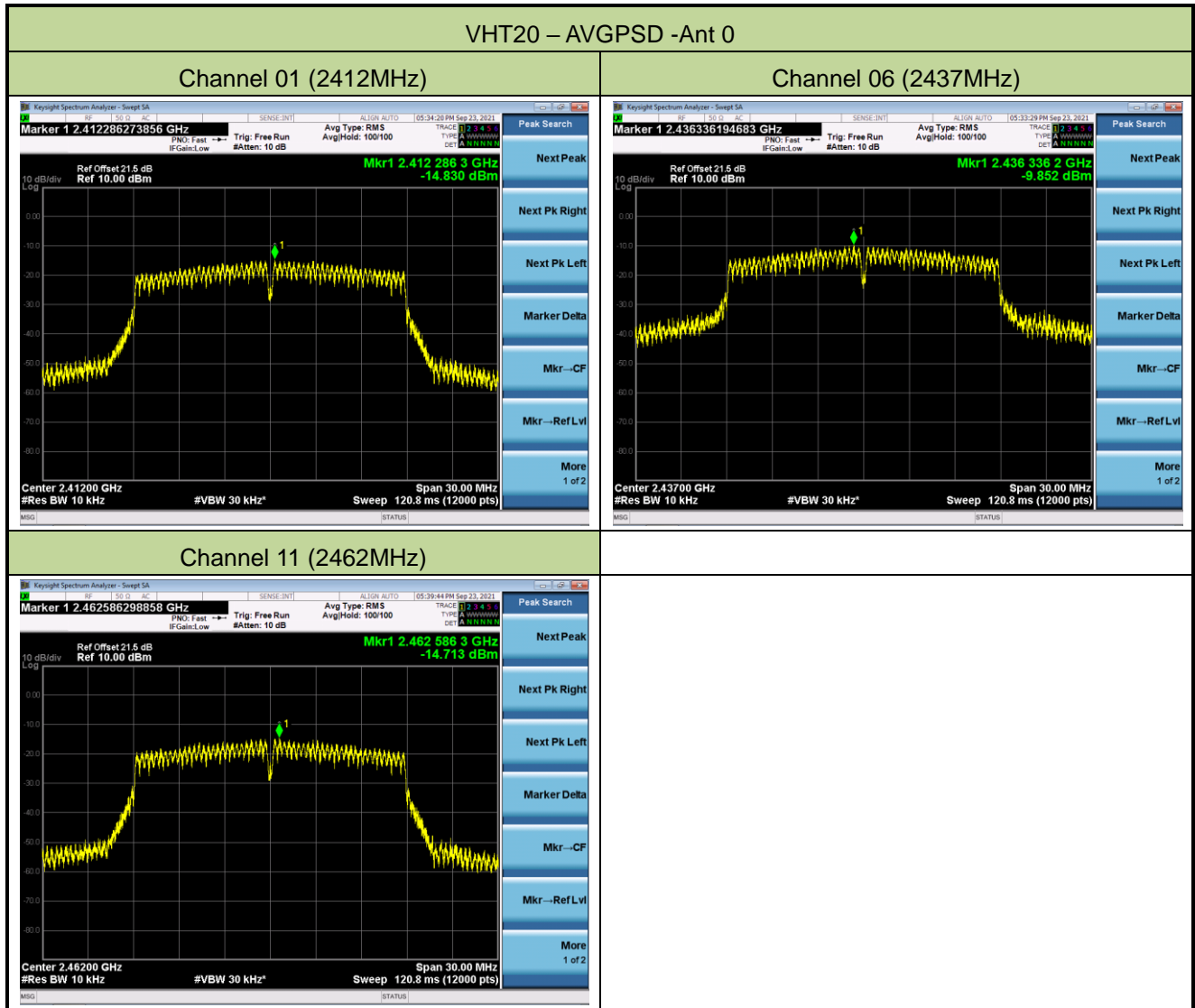

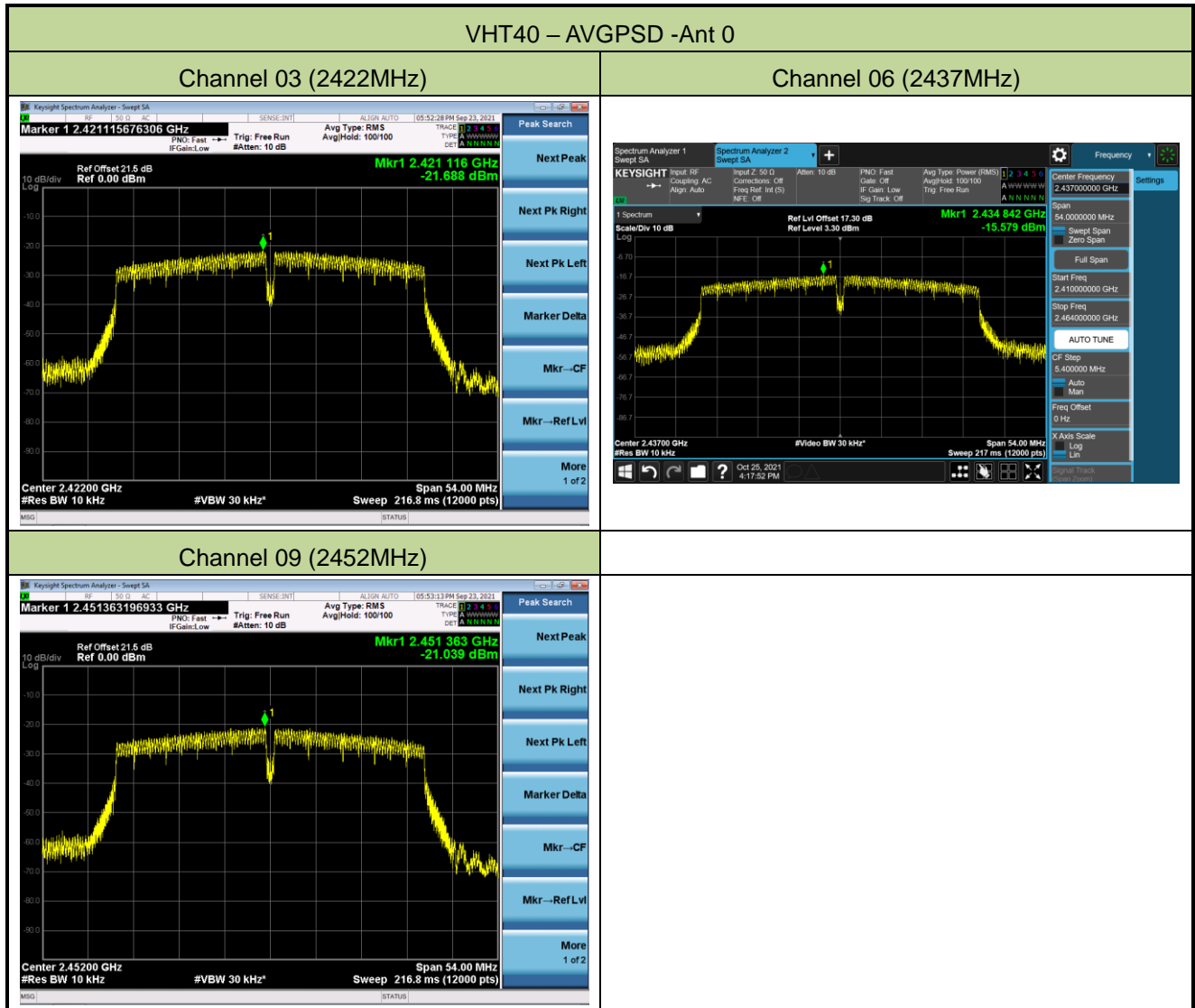

802.11b AVGPDS -Ant 1

Channel 01 (2412MHz)



Channel 06 (2437MHz)



Channel 11 (2462MHz)



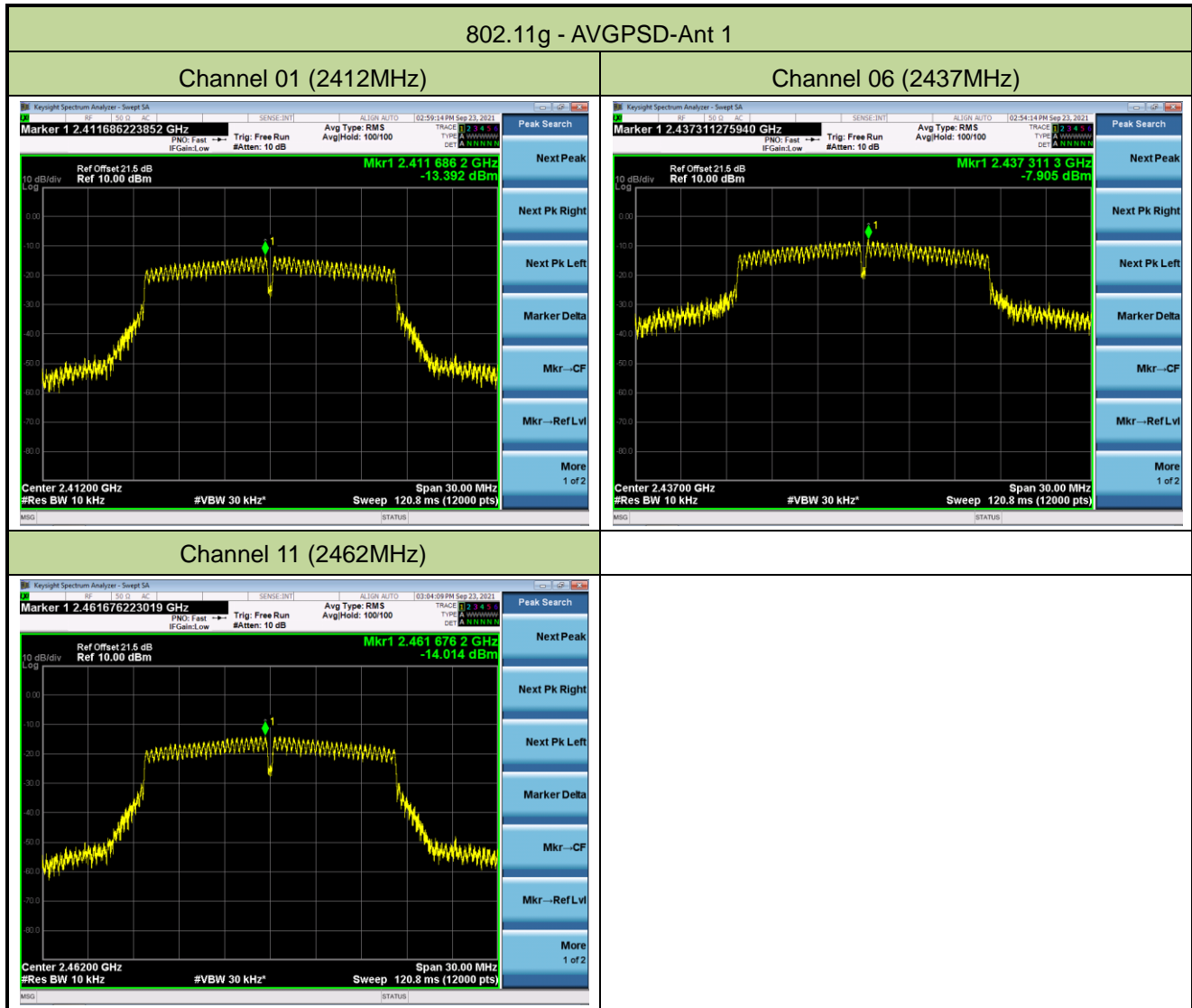

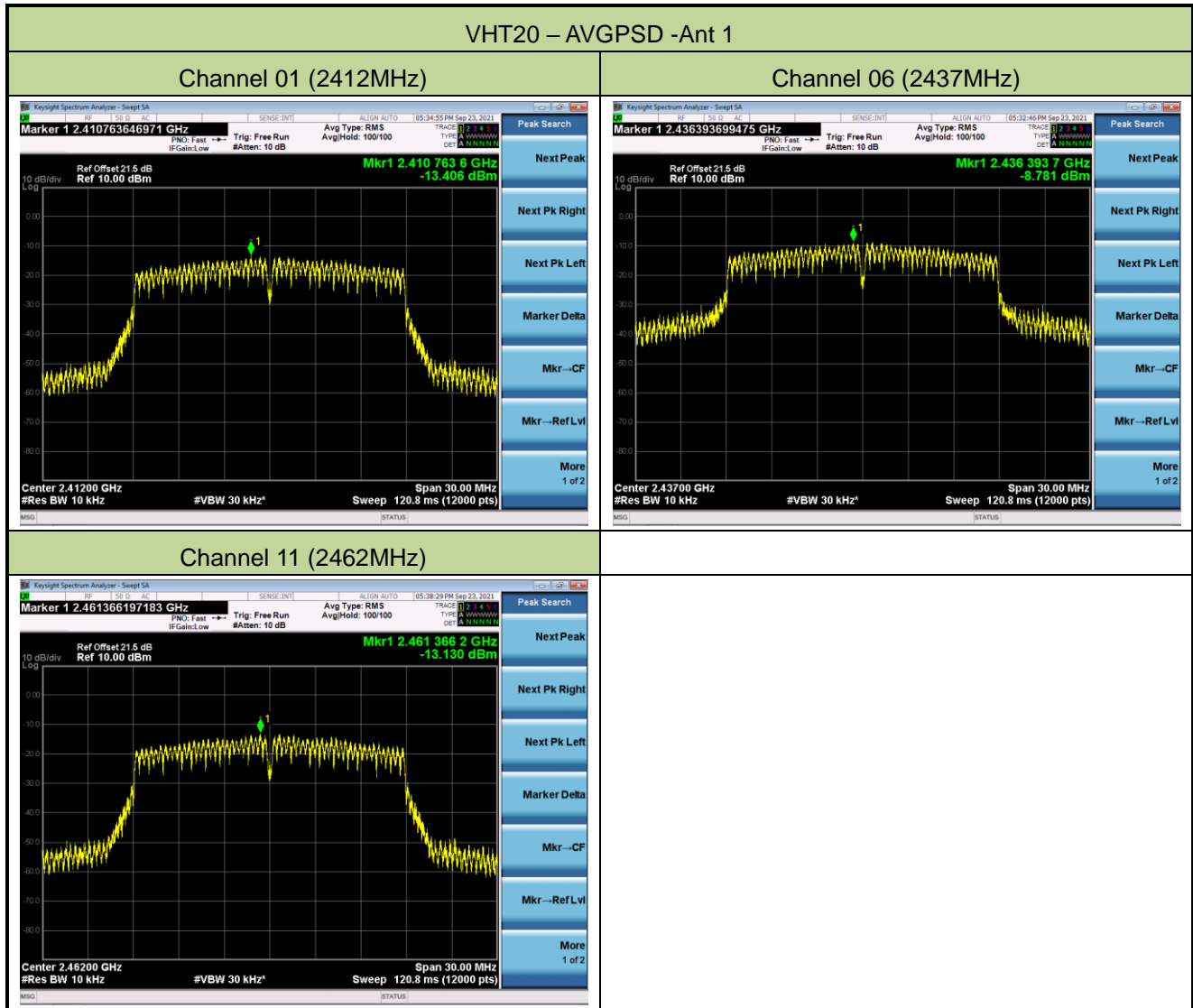

VHT40 – AVGPSD -Ant 1

Channel 03 (2422MHz)

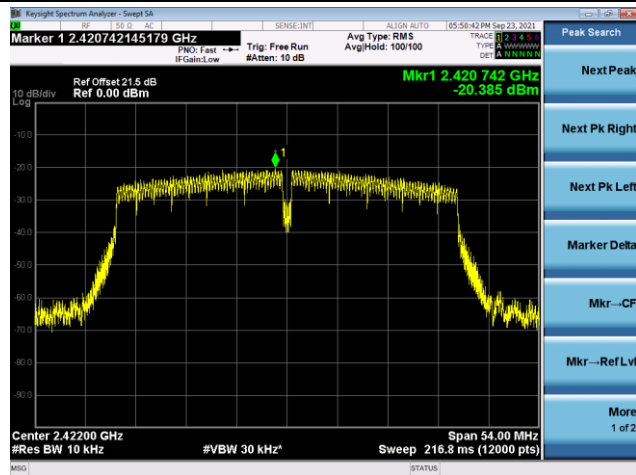

Channel 06 (2437MHz)

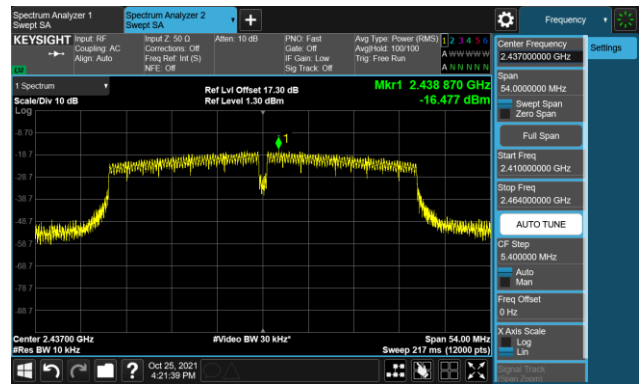

Channel 09 (2452MHz)

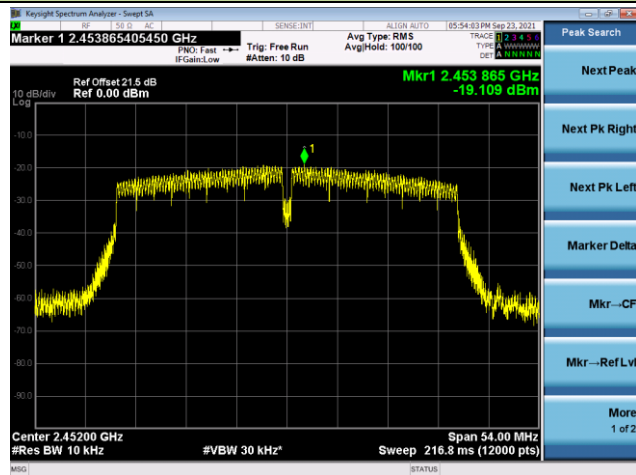

802.11b AVGPDS -Ant 2

Channel 01 (2412MHz)



Channel 06 (2437MHz)



Channel 11 (2462MHz)



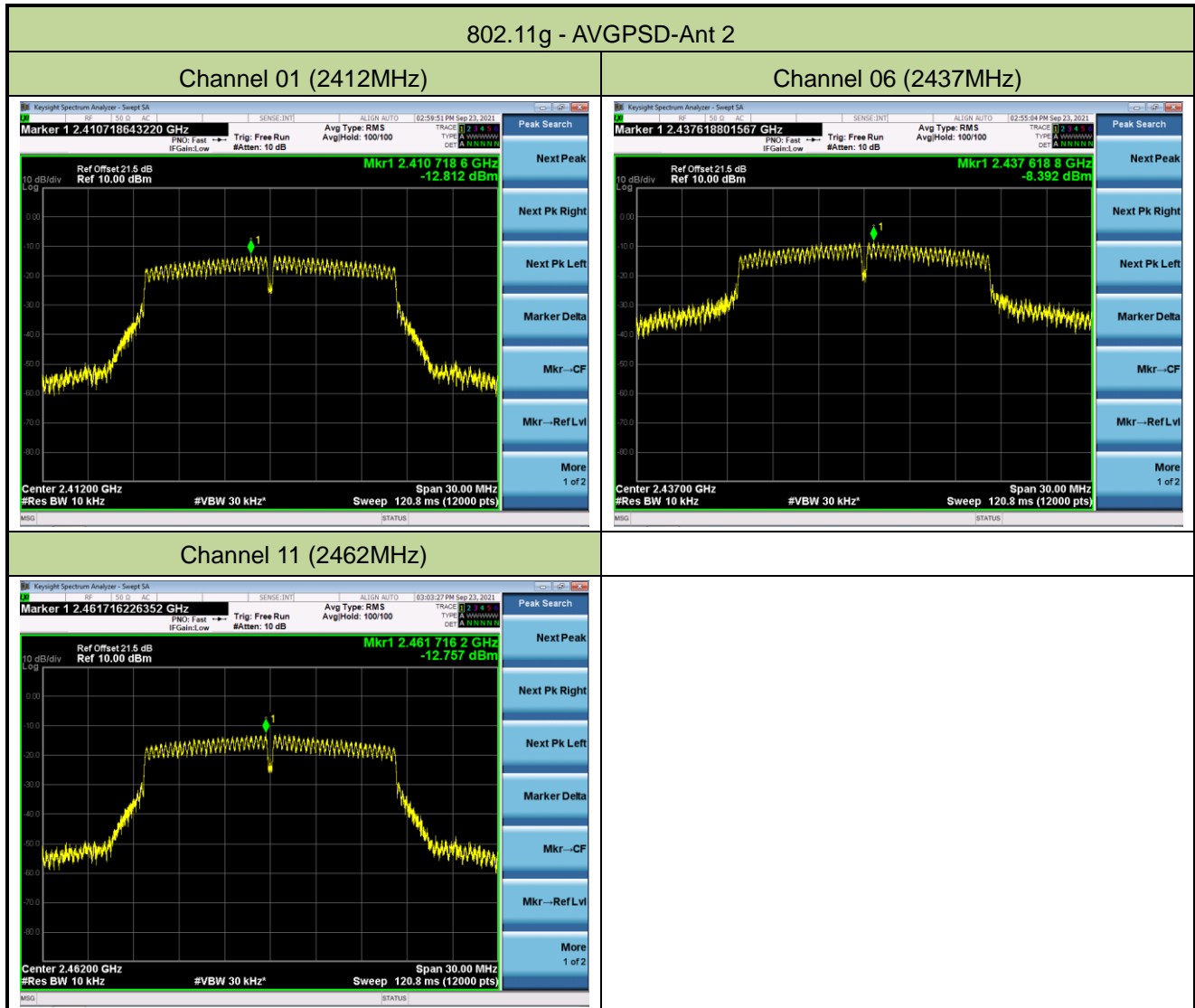

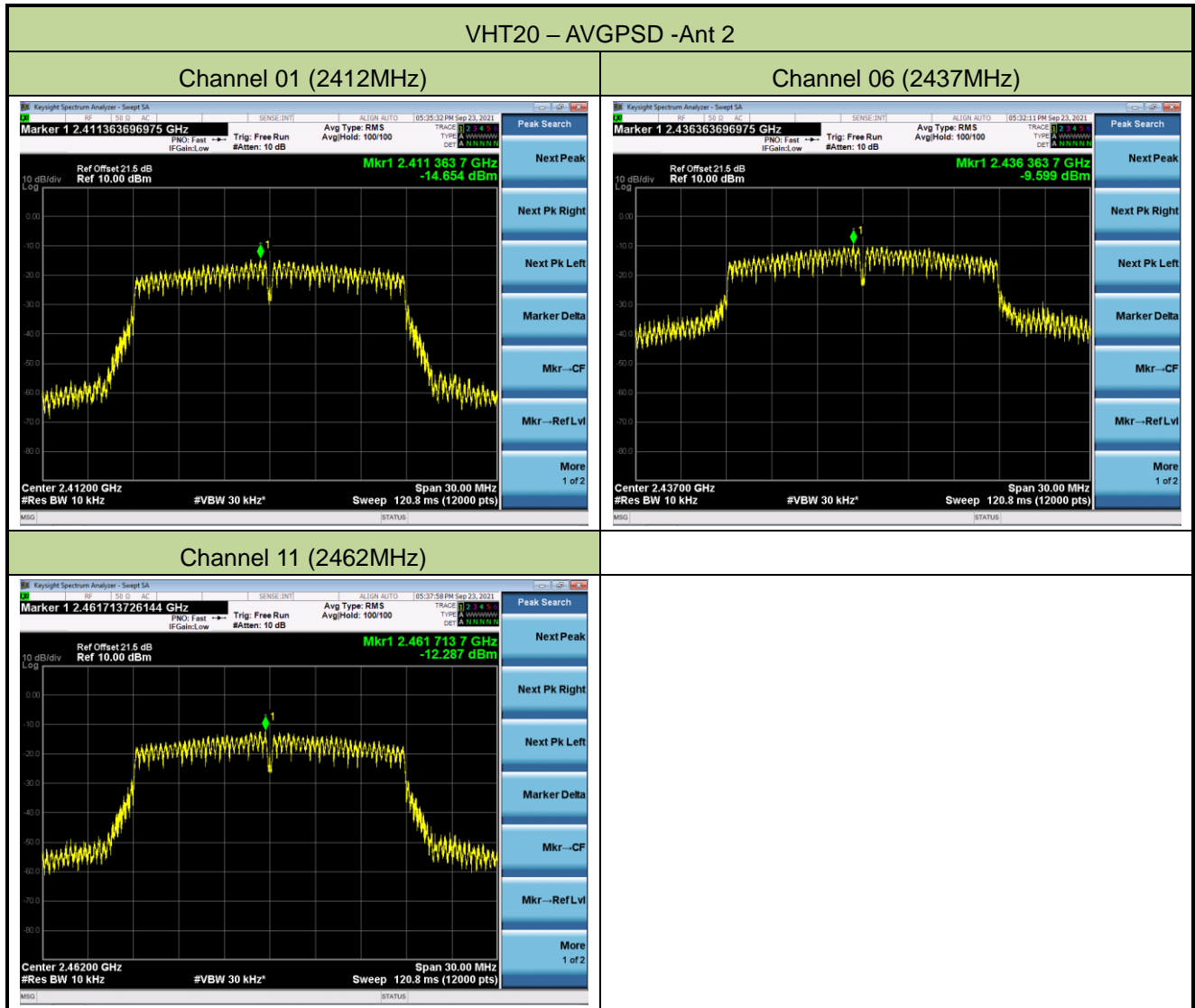

VHT40 – AVGPSD -Ant 2

Channel 03 (2422MHz)

Channel 06 (2437MHz)

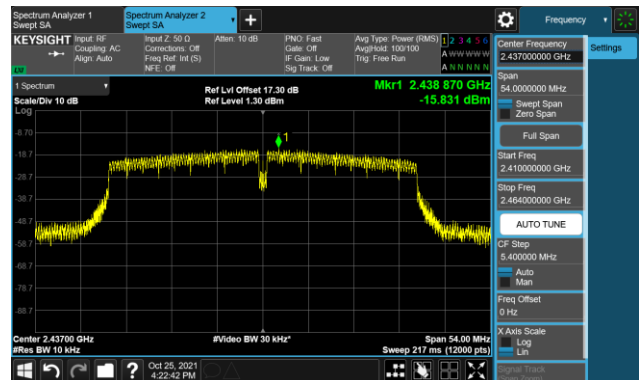
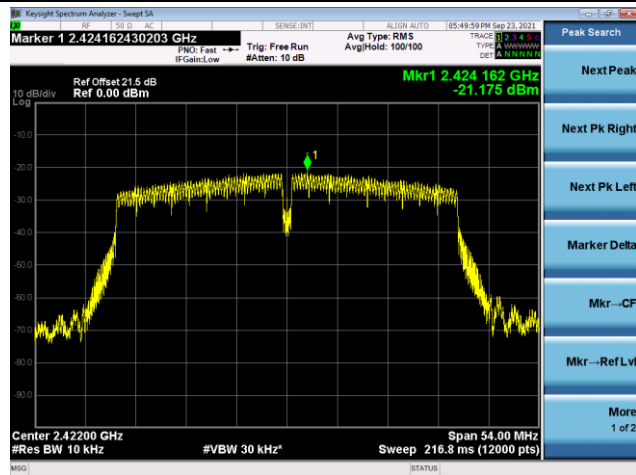

Channel 09 (2452MHz)

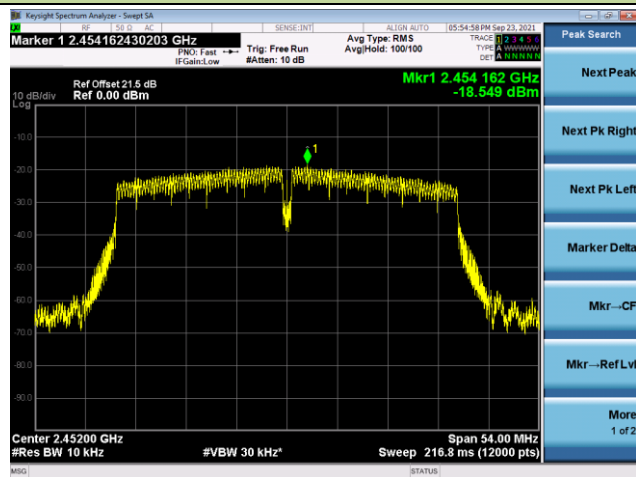

802.11b AVGPDS -Ant 3

Channel 01 (2412MHz)



Channel 06 (2437MHz)



Channel 11 (2462MHz)

