

802.11a Power Spectral Density – Ant 1/Ant 0 + 1

Channel 36 (5180MHz)

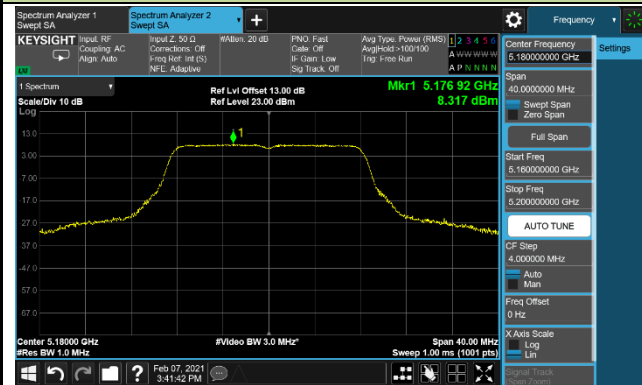

Channel 44 (5220MHz)

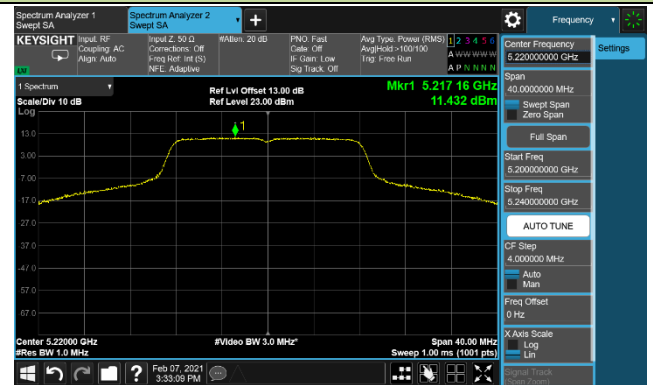

Channel 48 (5240MHz)

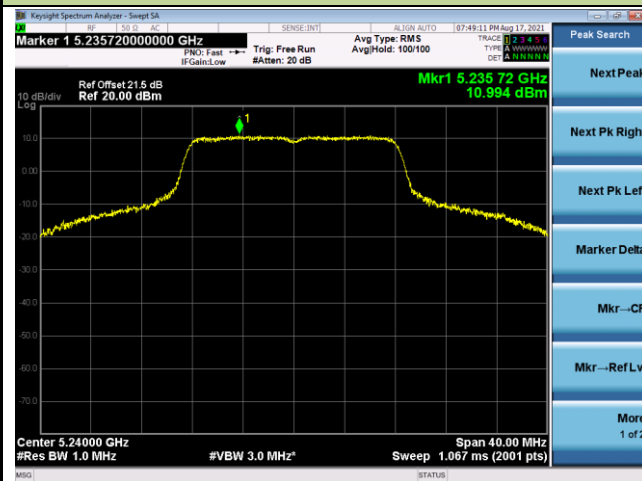

Channel 52 (5260MHz)

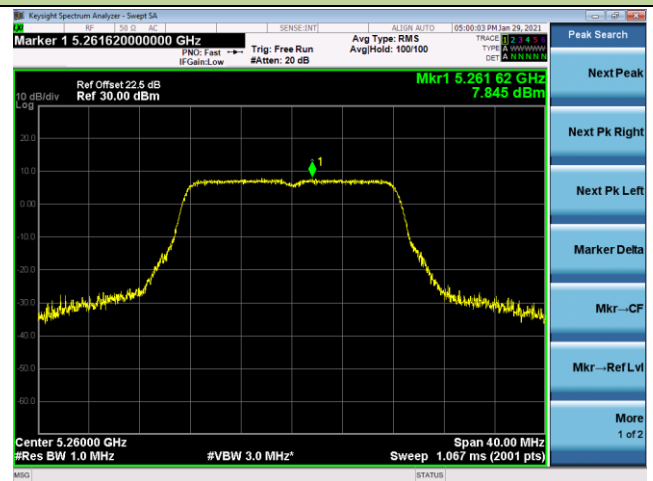

Channel 60 (5300MHz)

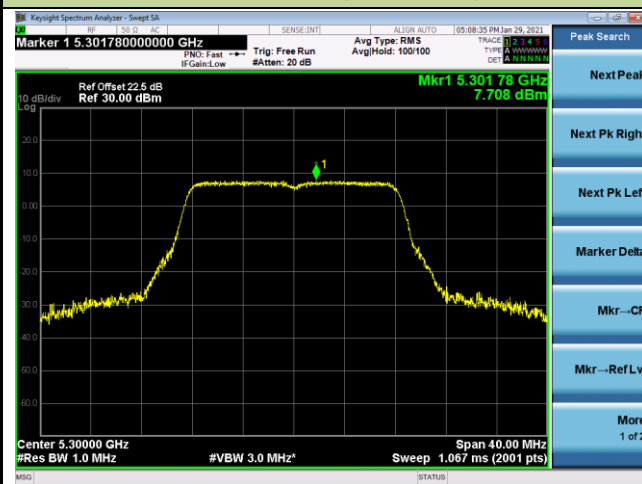

Channel 64 (5320MHz)

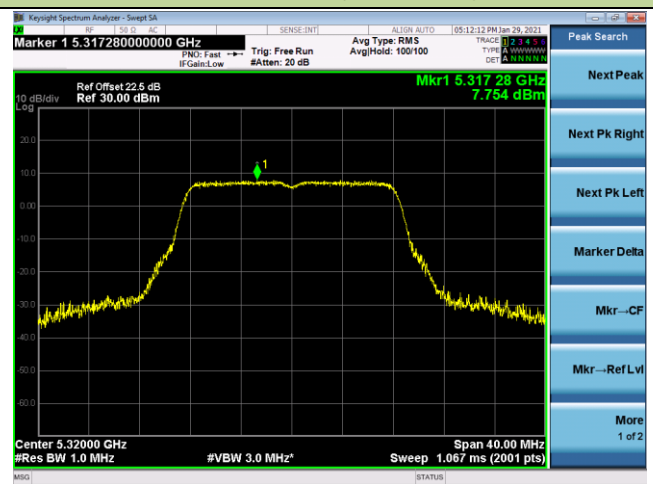

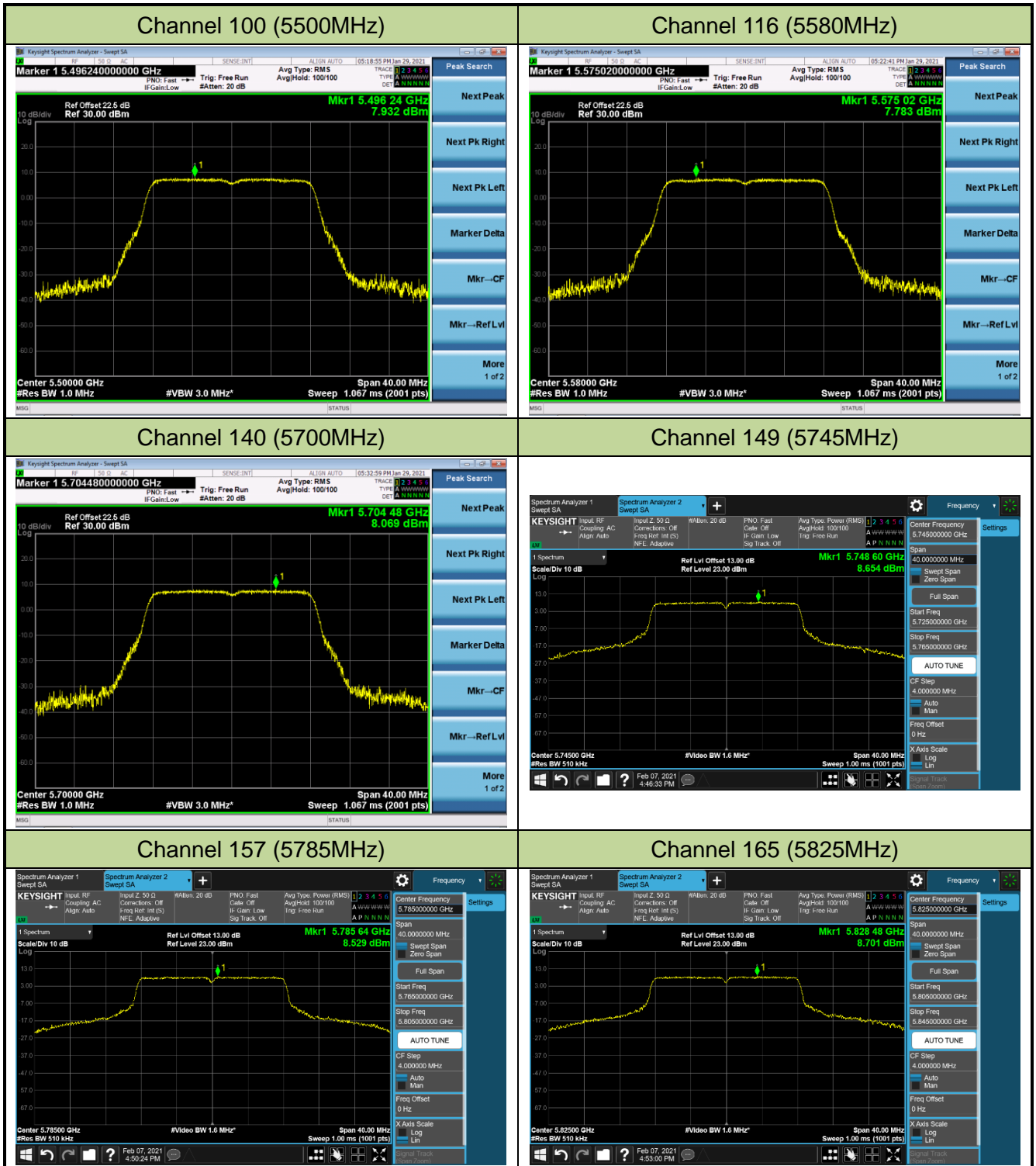

802.11ac-VHT20 Power Spectral Density – Ant 1/Ant 0 + 1

Channel 36 (5180MHz)

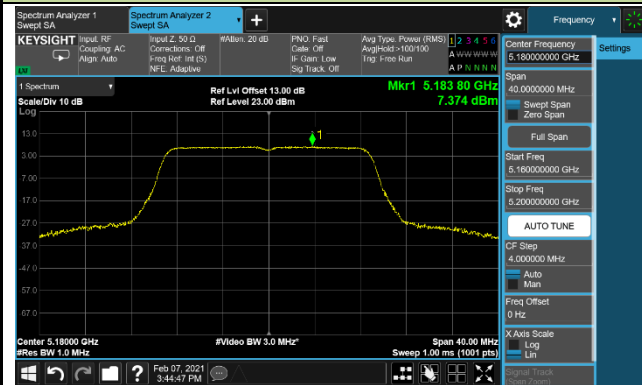

Channel 44 (5220MHz)

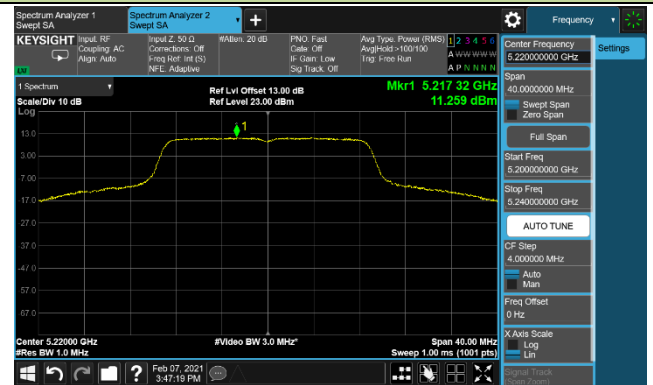

Channel 48 (5240MHz)

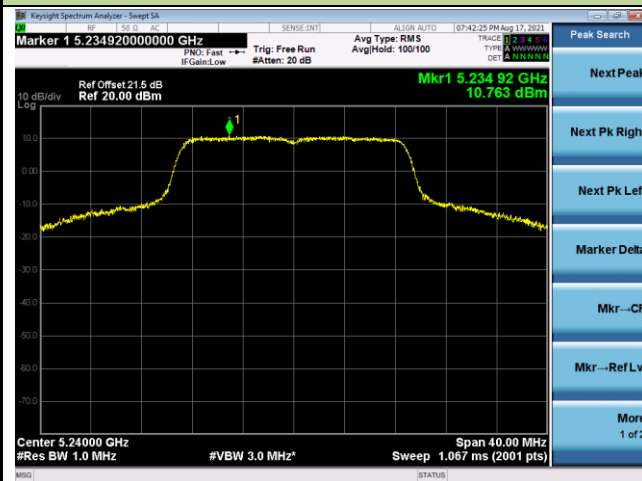

Channel 52 (5260MHz)

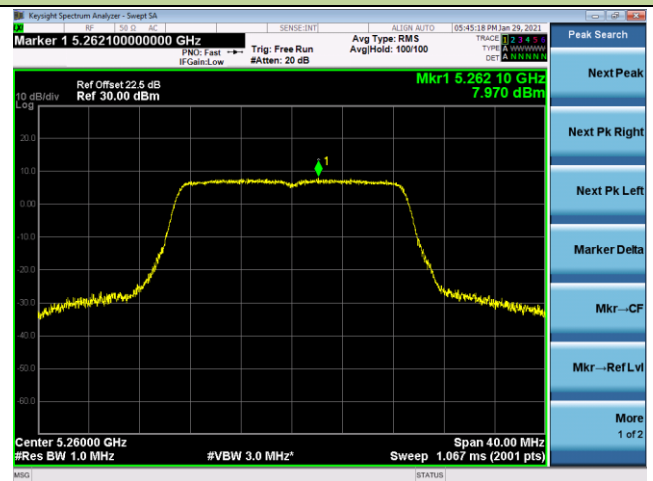

Channel 60 (5300MHz)

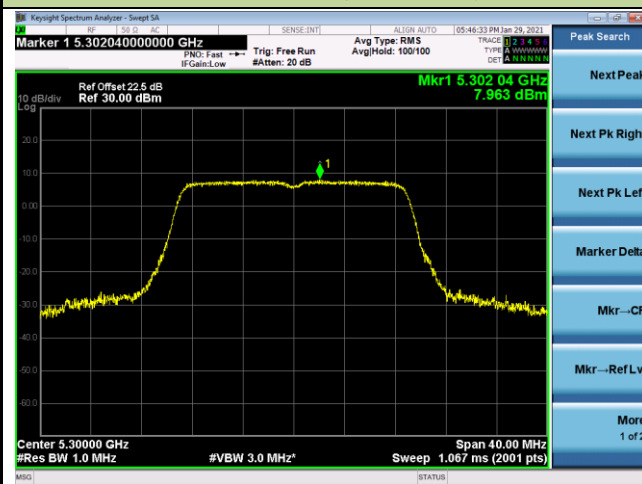

Channel 64 (5320MHz)

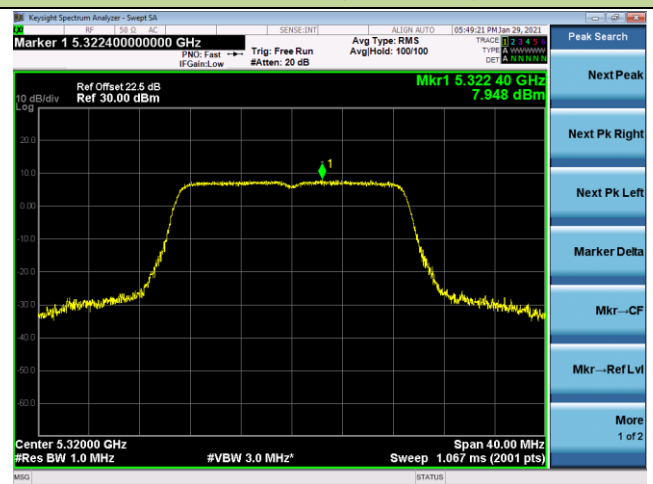

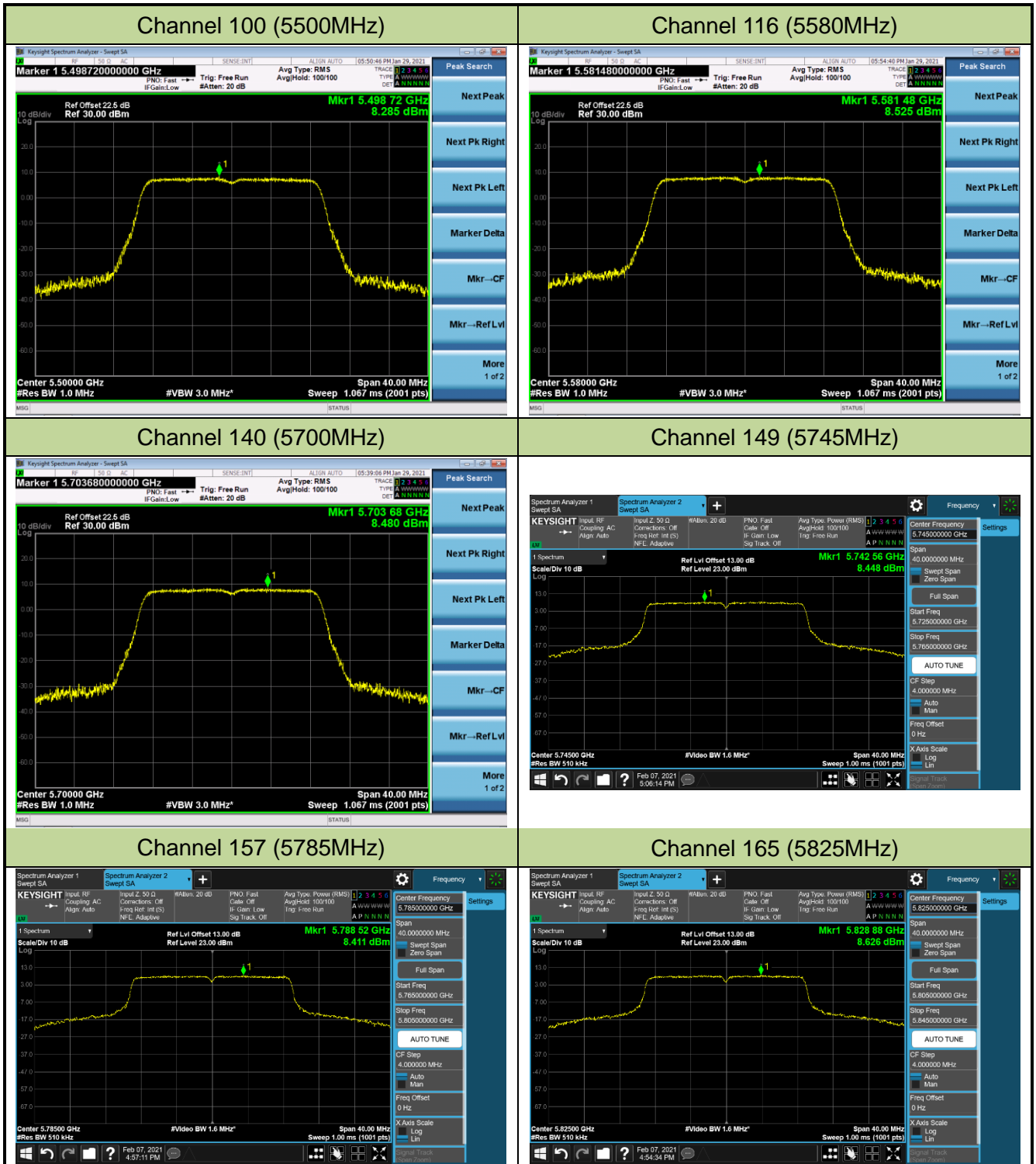

802.11ac-VHT40 Power Spectral Density – Ant 1/Ant 0 + 1

Channel 38 (5190MHz)

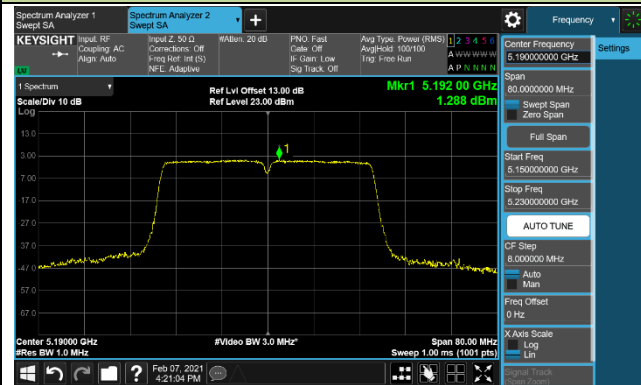

Channel 46 (5230MHz)

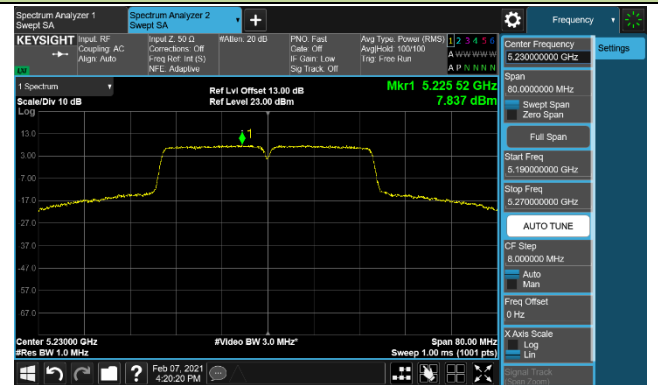

Channel 54 (5270MHz)

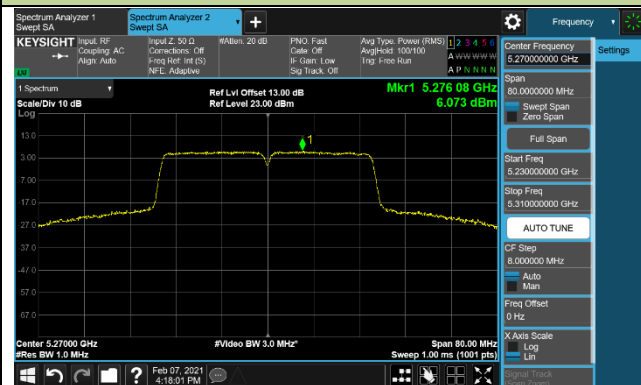

Channel 62 (5310MHz)

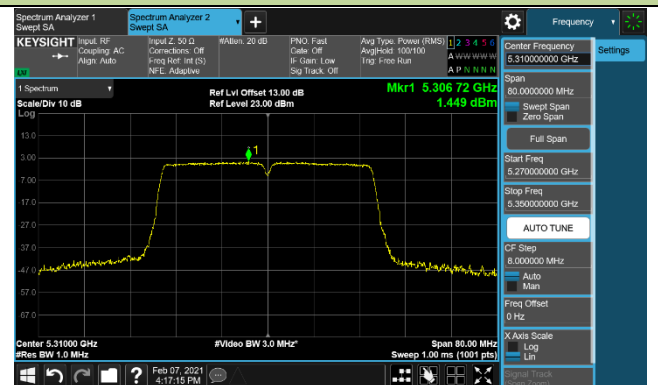

Channel 102 (5510MHz)

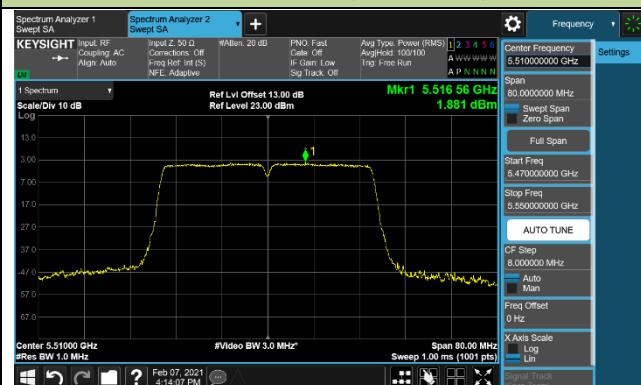

Channel 110 (5550MHz)

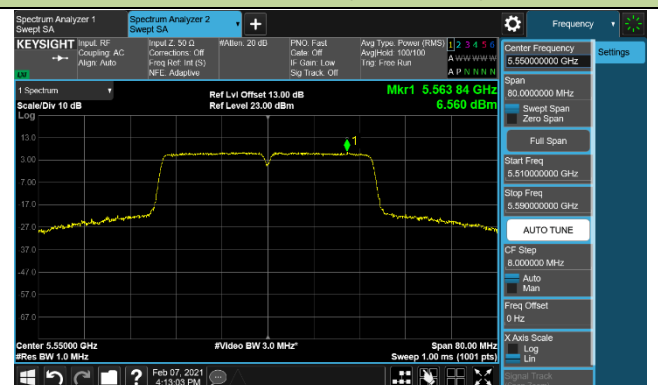

Channel 134 (5670MHz)

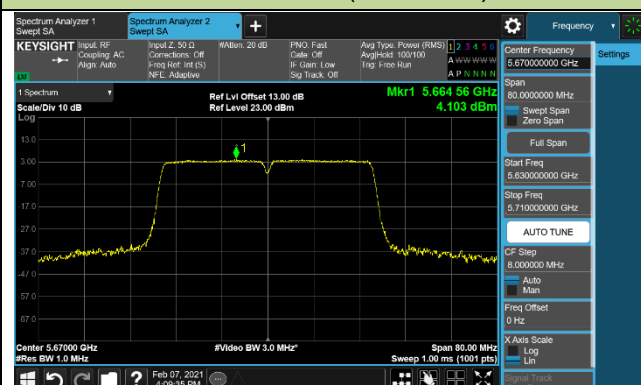

Channel 151 (5755MHz)

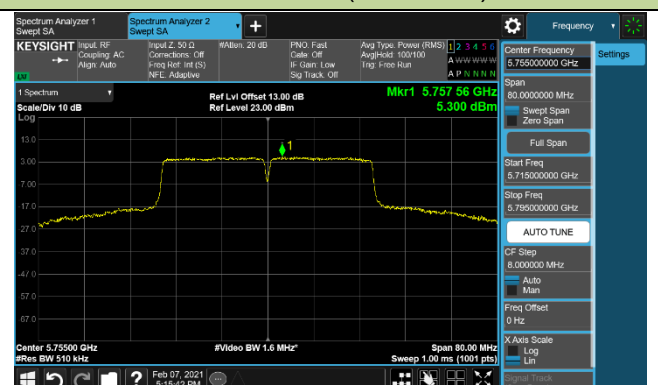

Channel 159 (5795MHz)

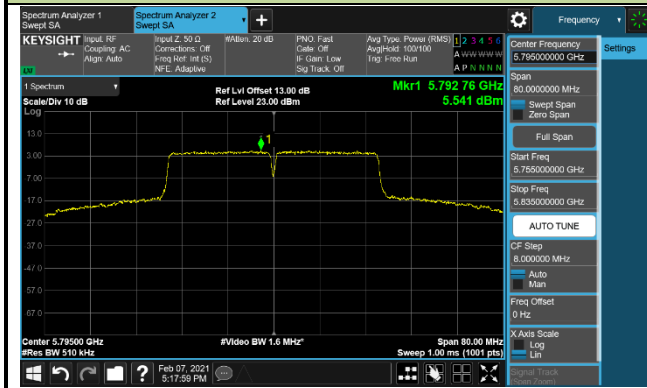

802.11ac-VHT80 Power Spectral Density – Ant 1/Ant 0 + 1

Channel 42 (5210MHz)

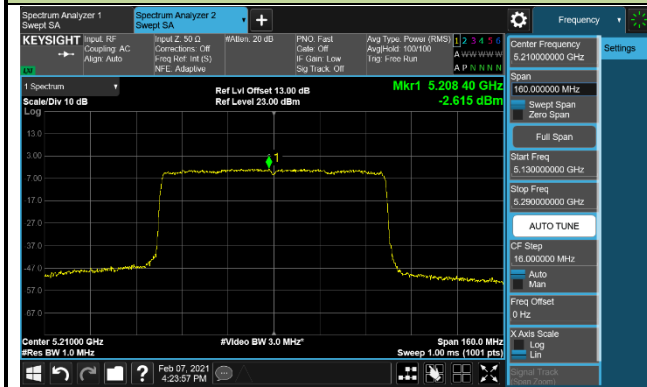

Channel 58 (5290MHz)

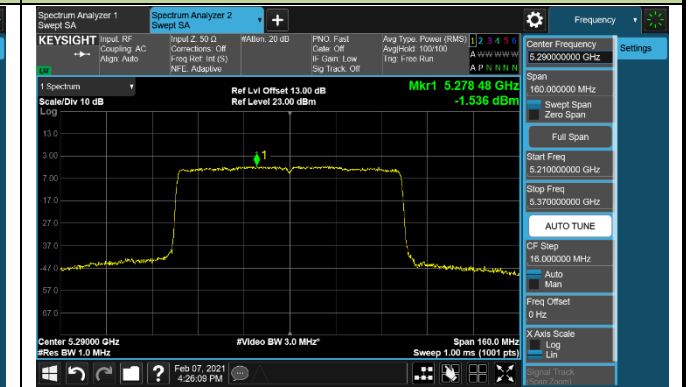

Channel 106 (5530MHz)

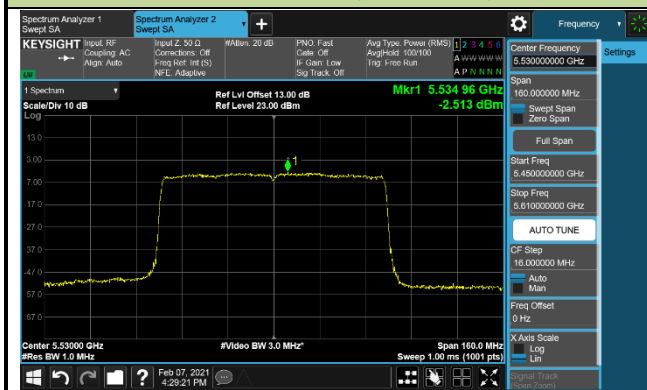

Channel 122 (5610MHz)

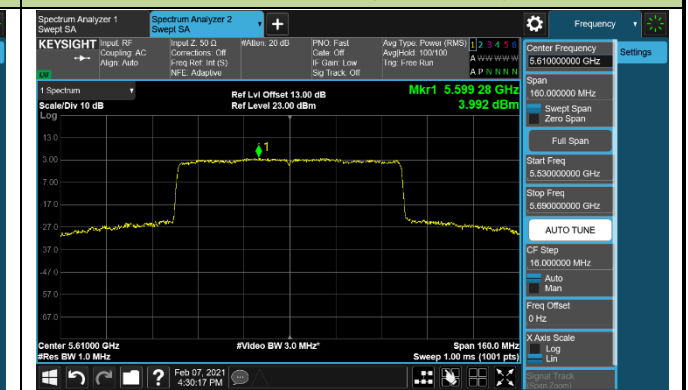

Channel 155 (5775MHz)

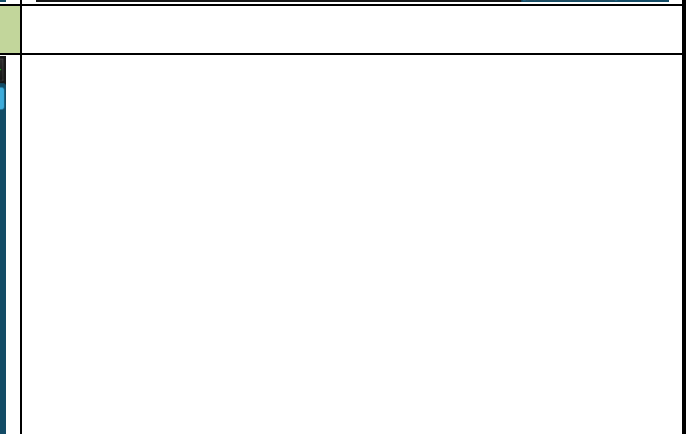
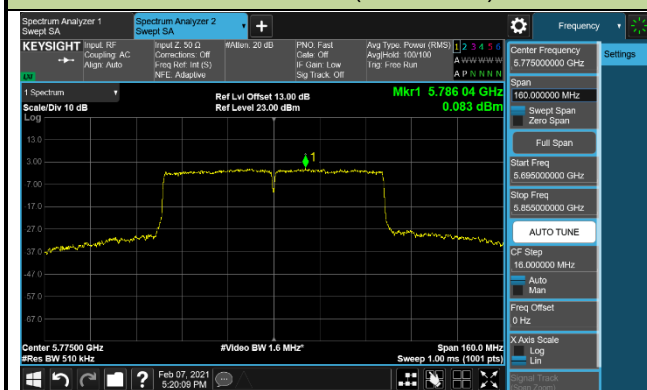

802.11ax-HE20 Power Spectral Density – Ant 1/Ant 0 + 1

Channel 36 (5180MHz)

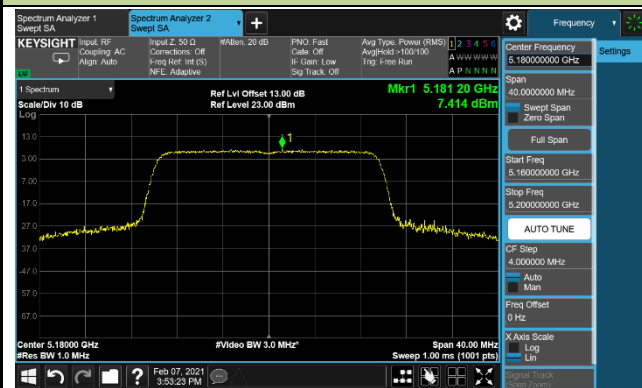

Channel 44 (5220MHz)

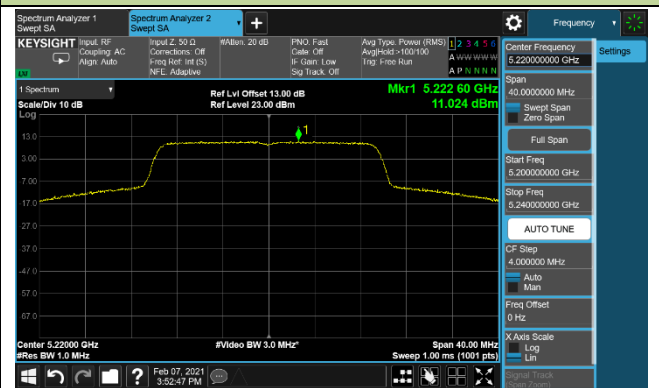

Channel 48 (5240MHz)

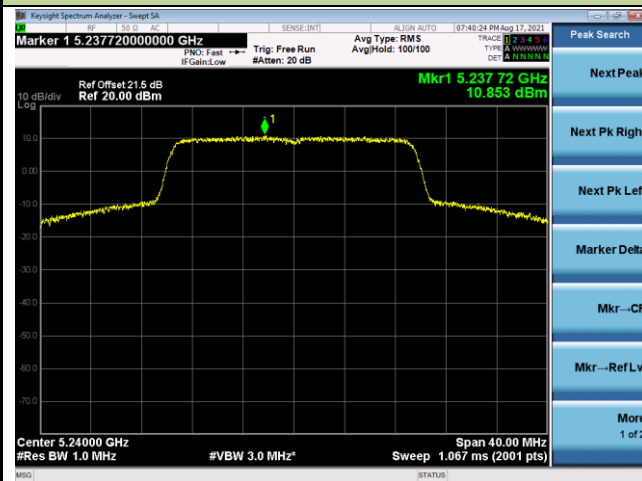

Channel 52 (5260MHz)

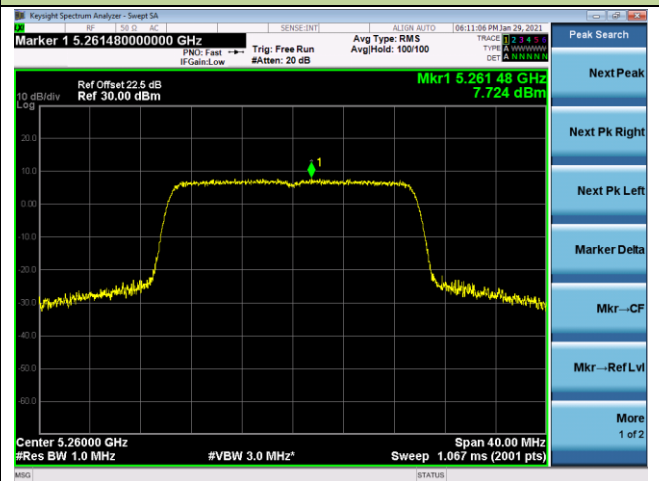

Channel 60 (5300MHz)

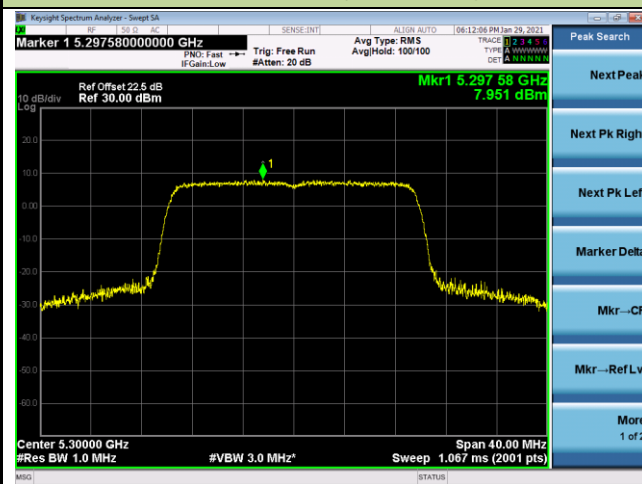

Channel 64 (5320MHz)

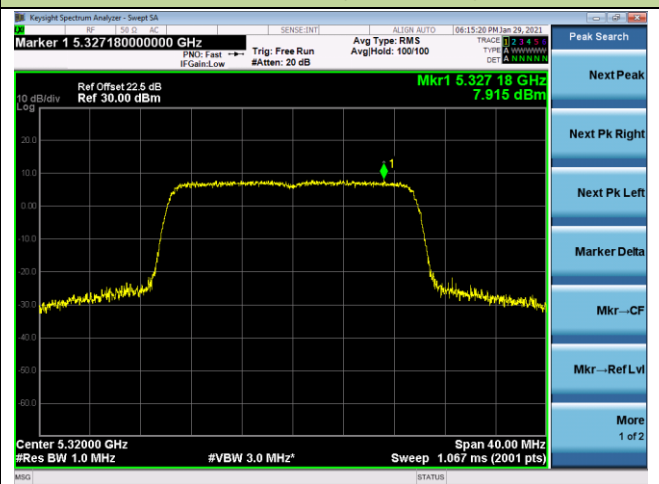

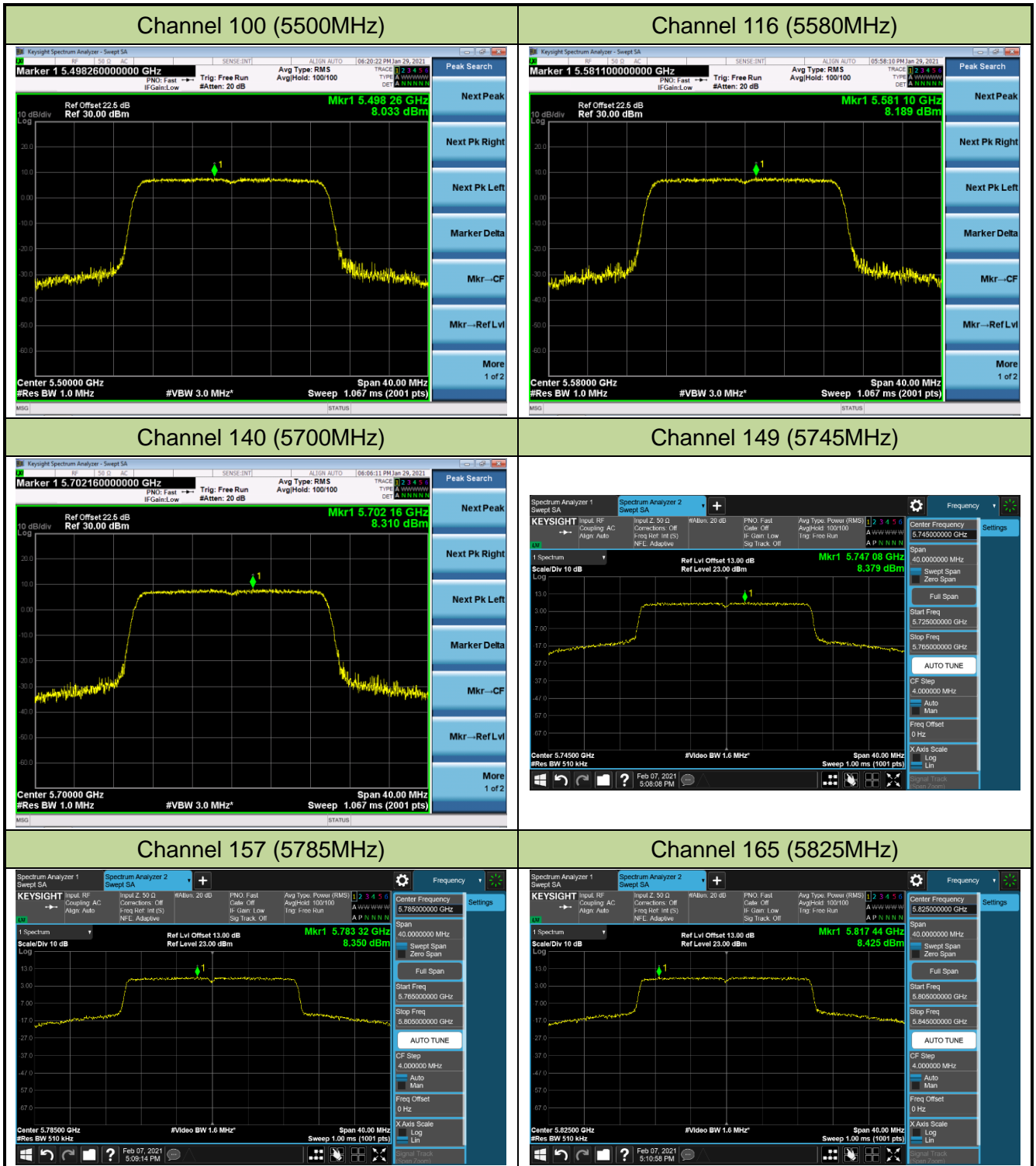

802.11ax-HE40 Power Spectral Density – Ant 1/Ant 0 + 1

Channel 38 (5190MHz)

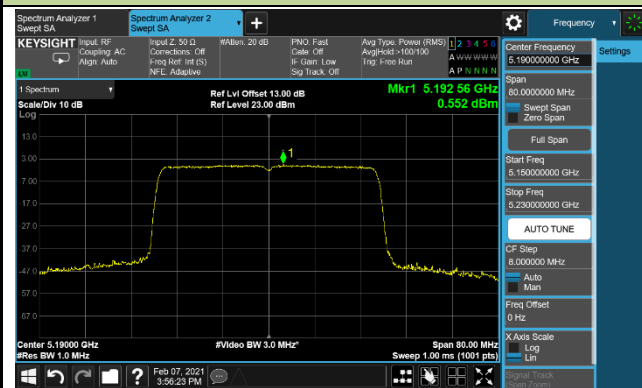

Channel 46 (5230MHz)

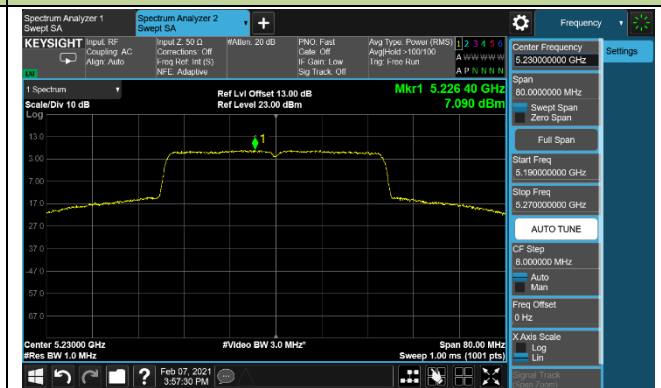

Channel 54 (5270MHz)

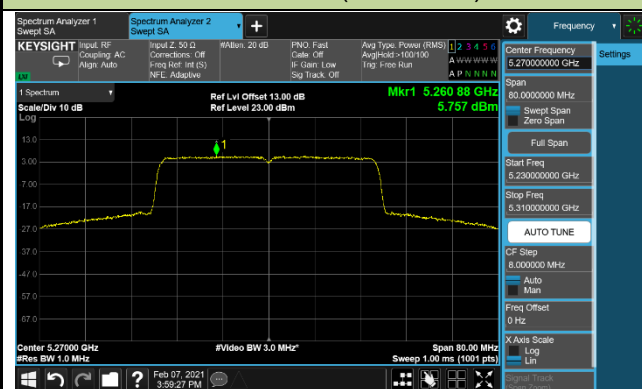

Channel 62 (5310MHz)

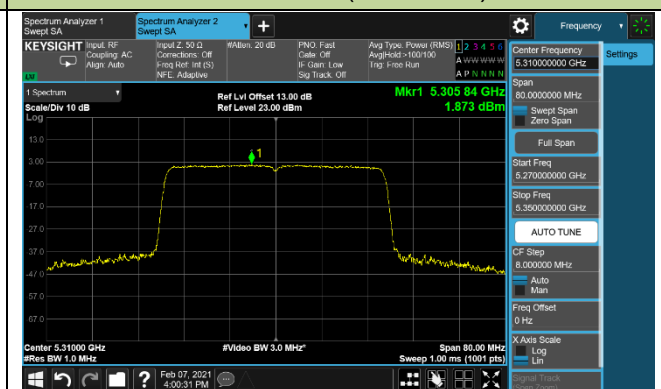

Channel 102 (5510MHz)

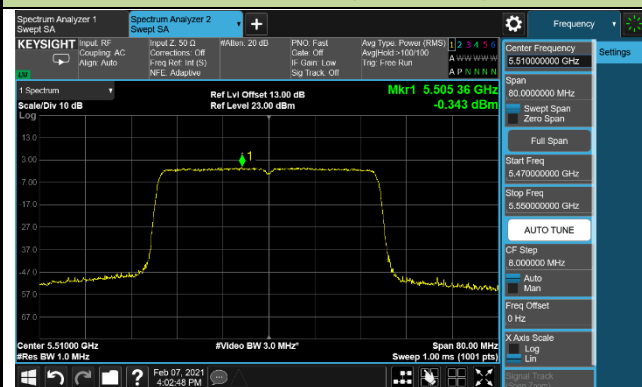

Channel 110 (5550MHz)

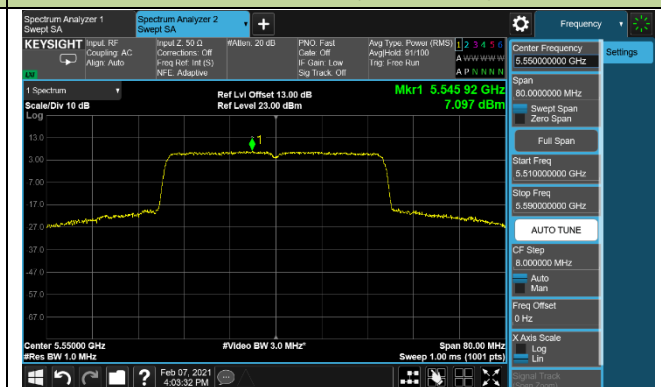

Channel 134 (5670MHz)

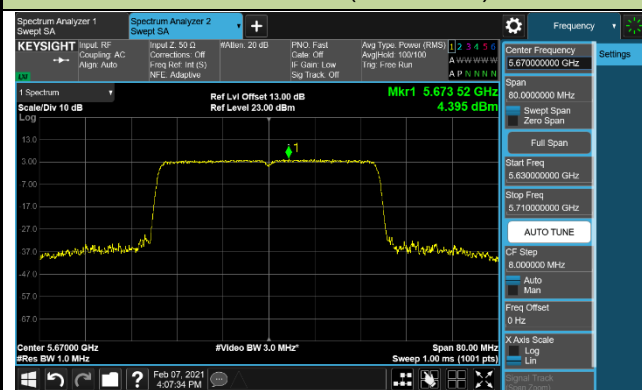

Channel 151 (5755MHz)

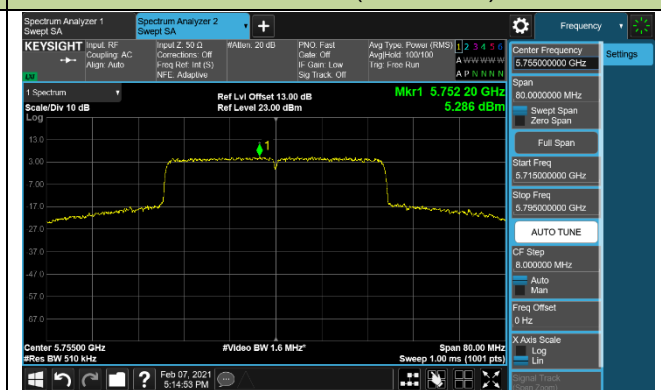



802.11ax-HE80 Power Spectral Density – Ant 1/Ant 0 + 1

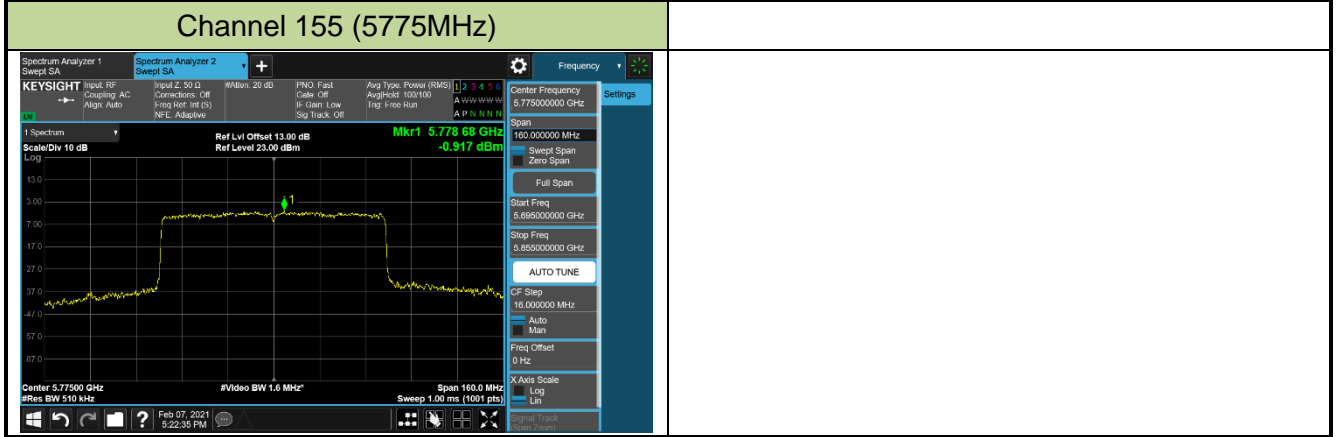
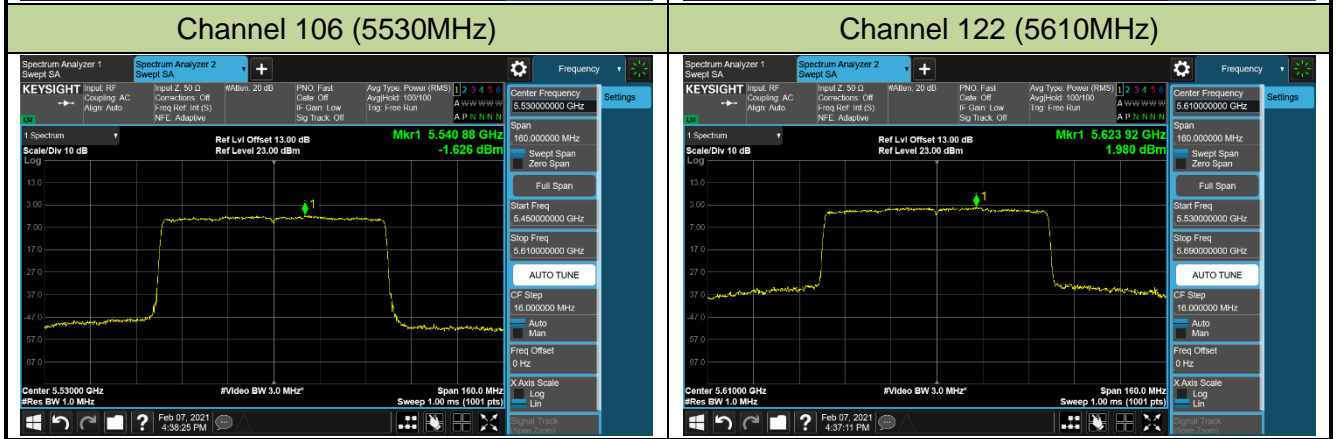
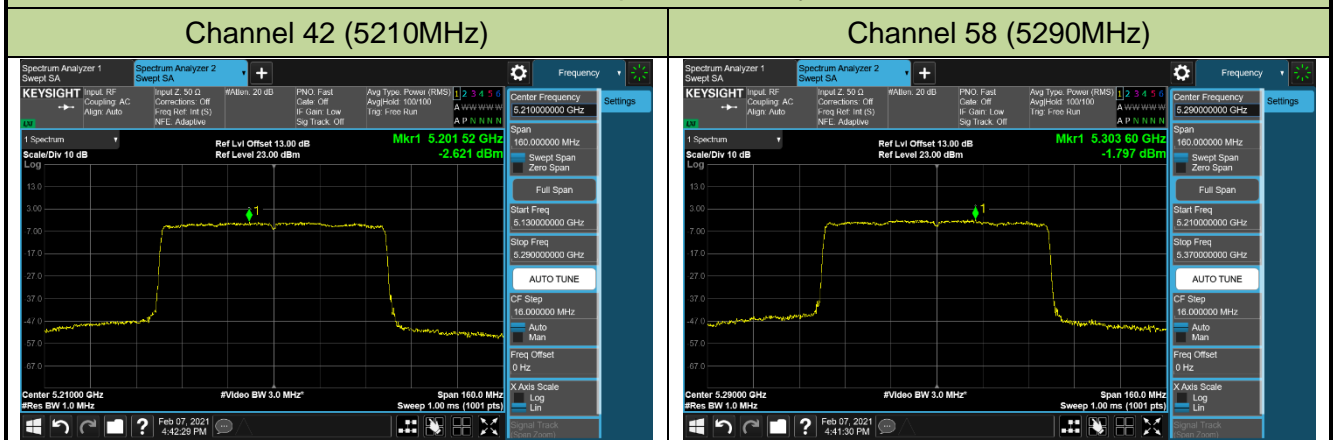

7.7. Frequency Stability Measurement

7.7.1. Test Limit

Manufactures of U-NII devices are responsible for ensuring frequency stability such that an emission is maintained within the band of operation under all conditions of normal operation as specified in the user's manual.

The transmitter center frequency tolerance shall be ± 20 ppm maximum for the 5GHz band (IEEE 802.11 specification).

7.7.2. Test Procedure Used

Frequency Stability Under Temperature Variations:

The equipment under test was connected to an external AC or DC power supply and input rated voltage. RF output was connected to a frequency counter or spectrum analyzer via feed through attenuators. The EUT was placed inside the temperature chamber. Set the spectrum analyzer RBW low enough to obtain the desired frequency resolution and measure EUT 20°C operating frequency as reference frequency. Turn EUT off and set the chamber temperature to highest. After the temperature stabilized for approximately 30 minutes recorded the frequency. Repeat step measure with 10°C decreased per stage until the lowest temperature reached.

Frequency Stability Under Voltage Variations:

Set chamber temperature to 20°C. Use a variable AC power supply / DC power source to power the EUT and set the voltage to rated voltage. Set the spectrum analyzer RBW low enough to obtain the desired frequency resolution and recorded the frequency.

Reduce the input voltage to specify extreme voltage variation ($\pm 15\%$) and endpoint, record the maximum frequency change.

7.7.3.Test Setup

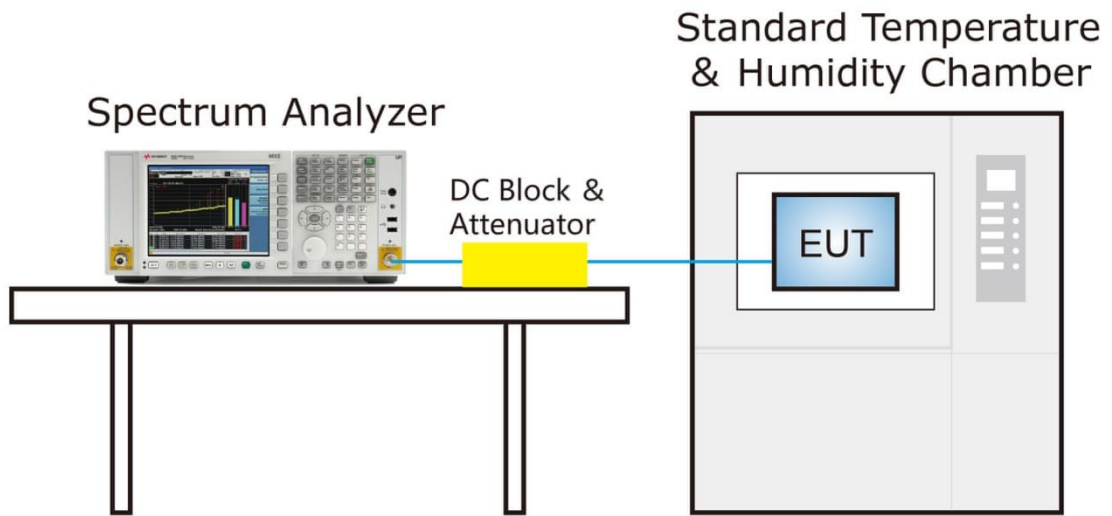

7.7.4.Test Result

Product	AX1800 Wi-Fi 6 Range Extender	Temperature	24°C
Test Engineer	Eric Lin	Relative Humidity	45%RH
Test Site	SR2	Test Date	2021/06/01
Test Mode	5180MHz (Carrier Mode)		

Voltage (%)	Power (VAC)	Temp (°C)	Frequency Tolerance (ppm)			
			0 minutes	2 minutes	5 minutes	10 minutes
100%	120	0	7.72	0.00	0.00	-13.51
		+ 10	17.37	5.79	0.00	-13.51
		+ 20	-5.79	11.58	0.00	-7.72
		+ 30	19.31	-1.93	-9.65	3.86
		+ 40	13.51	23.17	-1.93	-3.86
115%	138	+ 20	-1.93	1.93	-15.44	9.65
85%	102	+ 20	11.58	1.93	-1.93	-11.58

Note: Frequency Tolerance (ppm) = $\frac{[\text{Measured Frequency (Hz)} - \text{Declared Frequency (Hz)}]}{\text{Declared Frequency (Hz)}} * 10^6$.

7.8. Radiated Spurious Emission Measurement

7.8.1. Test Limit

All out of band emissions appearing in a restricted band as specified in Section 15.205 of the Title 47CFR must not exceed the limits shown in Table per Section 15.209.

FCC Part 15 Subpart C Paragraph 15.209		
Frequency [MHz]	Field Strength [uV/m]	Measured Distance [Meters]
0.009 - 0.490	2400/F (kHz)	300
0.490 - 1.705	24000/F (kHz)	30
1.705 - 30	30	30
30 - 88	100	3
88 - 216	150	3
216 - 960	200	3
Above 960	500	3

7.8.2. Test Procedure Used

KDB 789033 D02v02r01- Section G

7.8.3. Test Setting

Table 1 - RBW as a function of frequency

Frequency	RBW
9 ~ 150 kHz	200 ~ 300 Hz
0.15 ~ 30 MHz	9 ~ 10 kHz
30 ~ 1000 MHz	100 ~ 120 kHz
>1000 MHz	1 MHz

Quasi-Peak Measurements below 1GHz

1. Analyzer center frequency was set to the frequency of the radiated spurious emission of interest
2. Span was set greater than 1MHz
3. RBW = as specified in Table 1
4. Detector = CISPR quasi-peak
5. Sweep time = auto couple
6. Trace was allowed to stabilize

Peak Measurements above 1GHz

1. Analyzer center frequency was set to the frequency of the radiated spurious emission of interest
2. RBW = 1MHz
3. VBW = 3MHz
4. Detector = peak
5. Sweep time = auto couple
6. Trace mode = max hold
7. Trace was allowed to stabilize

Average Measurements above 1GHz (Method VB)

1. Analyzer center frequency was set to the frequency of the radiated spurious emission of interest
2. RBW = 1MHz
3. VBW; If the EUT is configured to transmit with duty cycle $\geq 98\%$, set VBW = 10 Hz.
If the EUT duty cycle is $< 98\%$, set VBW $\geq 1/T$. T is the minimum transmission duration.
4. Detector = Peak
5. Sweep time = auto
6. Trace mode = max hold
7. Trace was allowed to stabilize

7.8.4. Test Setup

Below 1GHz Test Setup:

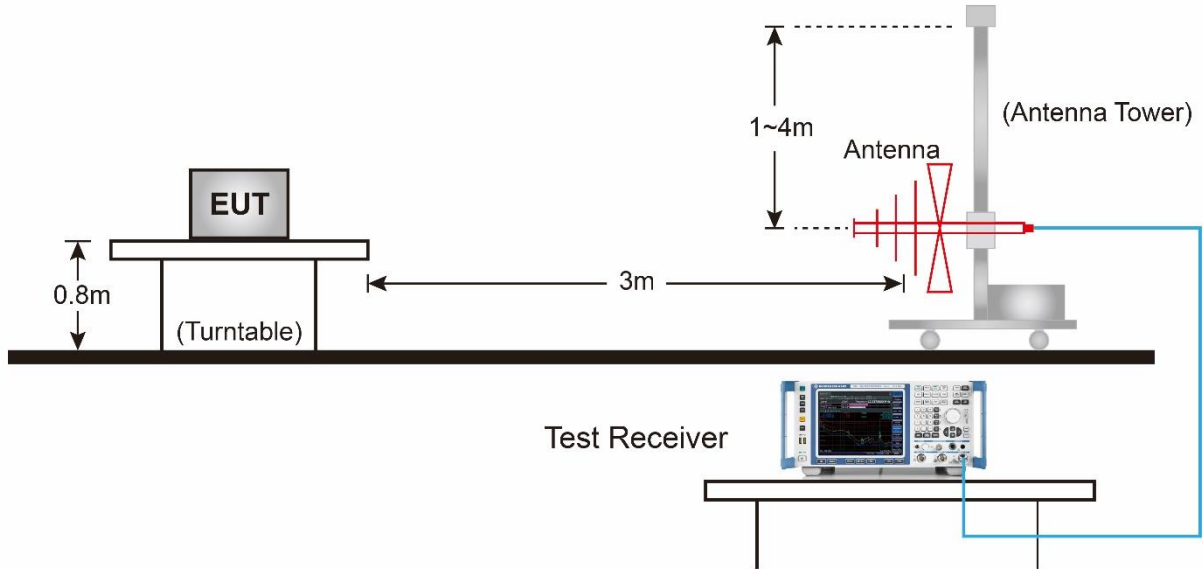

Above 1GHz Test Setup:

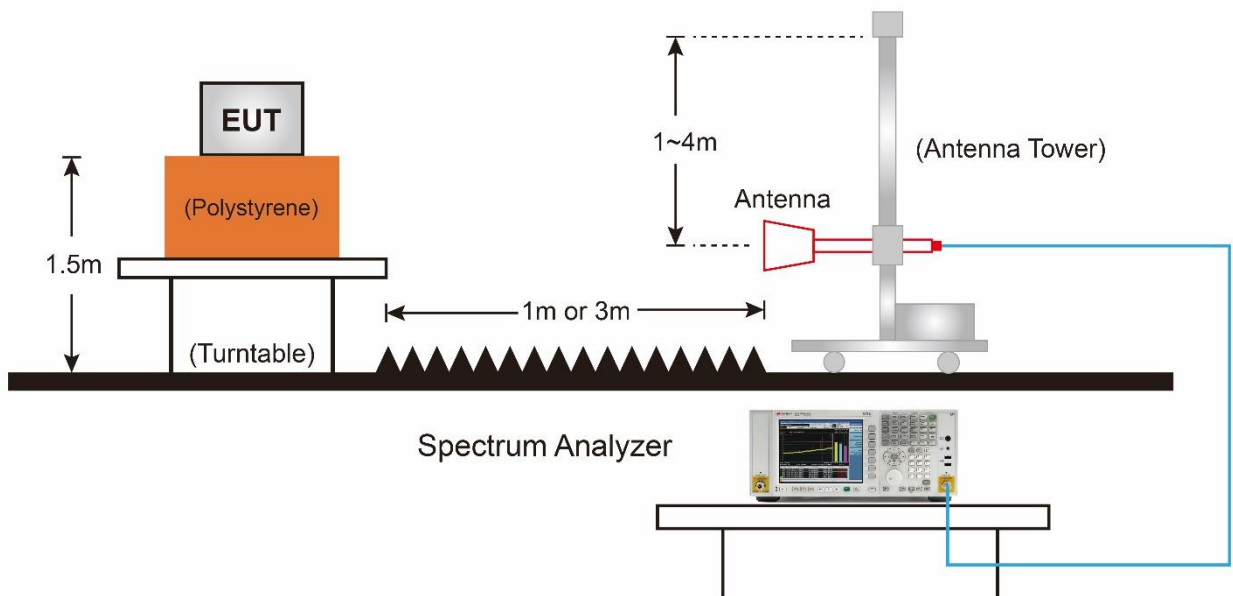

7.8.5.Test Result

EUT	AX1800 Wi-Fi 6 Range Extender	Date of Test	2021-05-07
Factor	BBHA 9120D (1GHz~18GHz)	Temp. / Humidity	25.4°C/52%
Polarity	Horizontal	Site / Test Engineer	AC1 / Jay
Test Mode	Transmit by 802.11a at Channel 5180MHz	Test Voltage	AC 120V/60Hz

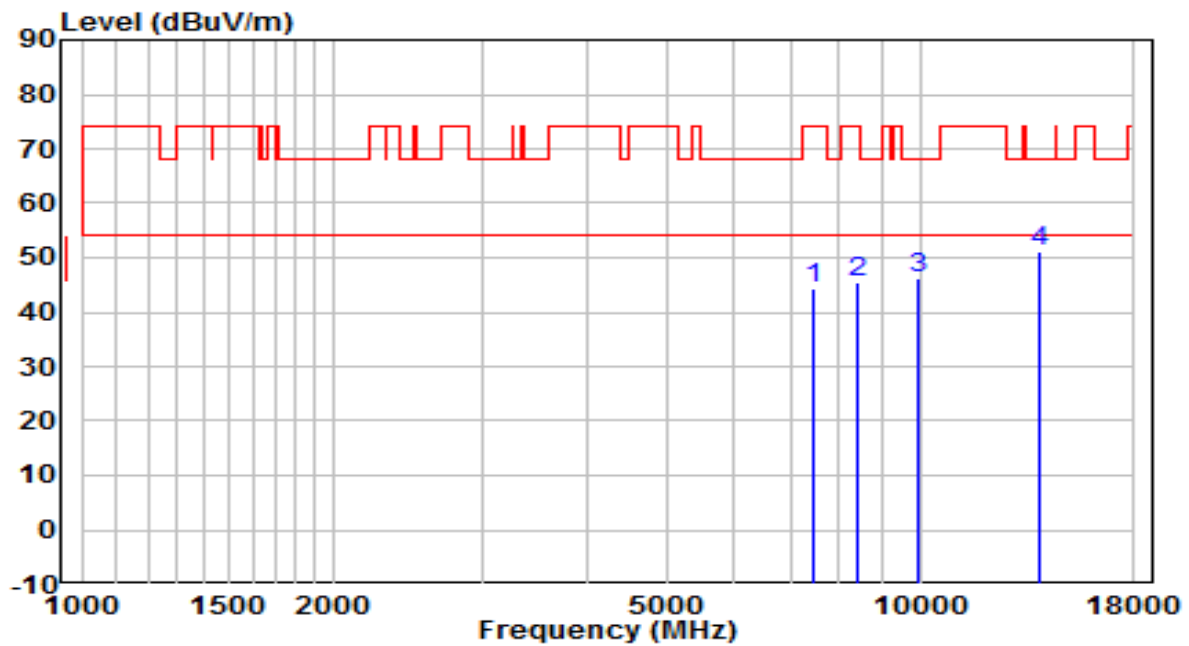

No	Frequency (MHz)	Reading (dBUV)	C.F (dB)	Measurement (dBUV/m)	Margin (dB)	Limit (dBUV/m)	Remark (QP/PK/AV)
1	7468.500	32.69	11.63	44.32	-29.68	74.00	Peak
2	8437.500	33.13	12.46	45.60	-28.40	74.00	Peak
3	9959.000	31.11	15.28	46.39	-21.81	68.20	Peak
4	* 13869.000	30.05	21.27	51.32	-16.88	68.20	Peak

Note:

1. " *", means this data is the worst emission level.
2. C.F (Correction Factor) = Antenna Factor (dB)+ Cable Loss (dB)– Preamplifier(dB).
3. Measurement(dBUV/m) = Reading(dBUV) + C.F (Correction Factor).
- 4.The emission levels of other frequencies are very lower than the limit and not show in test report.

EUT	AX1800 Wi-Fi 6 Range Extender	Date of Test	2021-05-07
Factor	BBHA 9120D (1GHz~18GHz)	Temp. / Humidity	25.4°C/52%
Polarity	Vertical	Site / Test Engineer	AC1 / Jay
Test Mode	Transmit by 802.11a at Channel 5180MHz	Test Voltage	AC 120V/60Hz

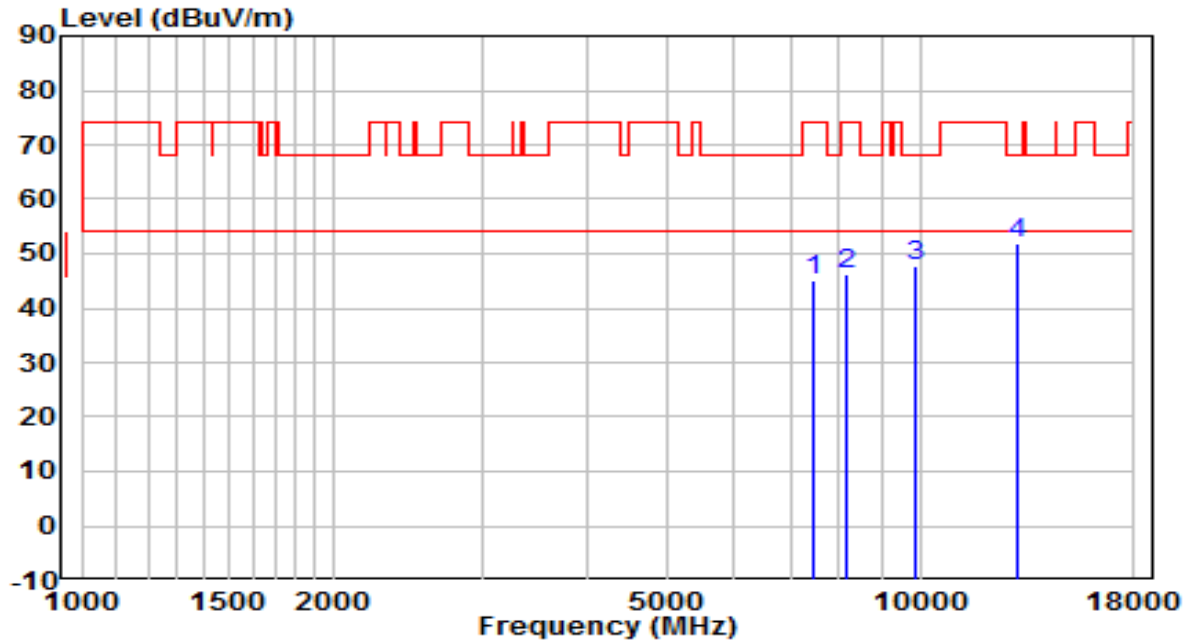

No	Frequency (MHz)	Reading (dBuV)	C.F (dB)	Measurement (dBuV/m)	Margin (dB)	Limit (dBuV/m)	Remark (QP/PK/AV)
1	7485.500	33.59	11.67	45.26	-28.74	74.00	Peak
2	8182.500	33.68	12.50	46.19	-27.81	74.00	Peak
3	9899.500	32.50	15.17	47.67	-20.53	68.20	Peak
4	* 13087.000	32.23	19.51	51.74	-16.46	68.20	Peak

Note:

- "*" means this data is the worst emission level.
- C.F (Correction Factor) = Antenna Factor (dB)+ Cable Loss (dB)– Preamplifier(dB).
- Measurement(dBuV/m) = Reading(dBuV) + C.F (Correction Factor).
- The emission levels of other frequencies are very lower than the limit and not show in test report.

EUT	AX1800 Wi-Fi 6 Range Extender	Date of Test	2021-05-07
Factor	AC2_BBHA9120D_1-18GHz	Temp. / Humidity	25.4°C/52%
Polarity	Horizontal	Site / Test Engineer	AC1 / Jay
Test Mode	Transmit by 802.11a at Channel 5220MHz	Test Voltage	AC 120V/60Hz

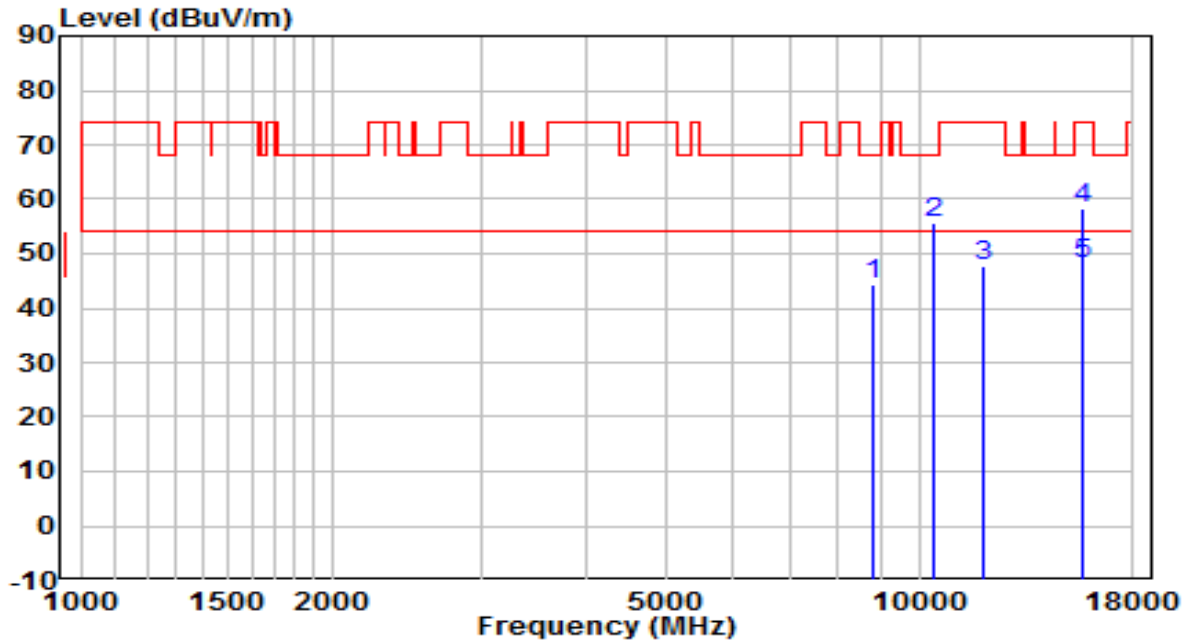

No	Frequency (MHz)	Reading (dBUV)	C.F (dB)	Measurement (dBUV/m)	Margin (dB)	Limit (dBUV/m)	Remark (QP/PK/AV)
1	8786.000	29.97	14.47	44.44	-23.76	68.20	Peak
2	10443.500	39.31	16.41	55.72	-12.48	68.20	Peak
3	11888.500	29.85	18.04	47.89	-26.11	74.00	Peak
4	15654.000	37.72	20.44	58.15	-15.85	74.00	Peak
5	* 15662.700	27.30	20.71	48.01	-5.99	54.00	Average

Note:

1. " *", means this data is the worst emission level.
2. C.F (Correction Factor) = Antenna Factor (dB)+ Cable Loss (dB)– Preamplifier(dB).
3. Measurement(dBUV/m) = Reading(dBUV) + C.F (Correction Factor).
- 4.The emission levels of other frequencies are very lower than the limit and not show in test report.

EUT	AX1800 Wi-Fi 6 Range Extender	Date of Test	2021-05-07
Factor	BBHA 9120D (1GHz~18GHz)	Temp. / Humidity	25.4°C/52%
Polarity	Vertical	Site / Test Engineer	AC1 / Jay
Test Mode	Transmit by 802.11a at Channel 5220MHz	Test Voltage	AC 120V/60Hz

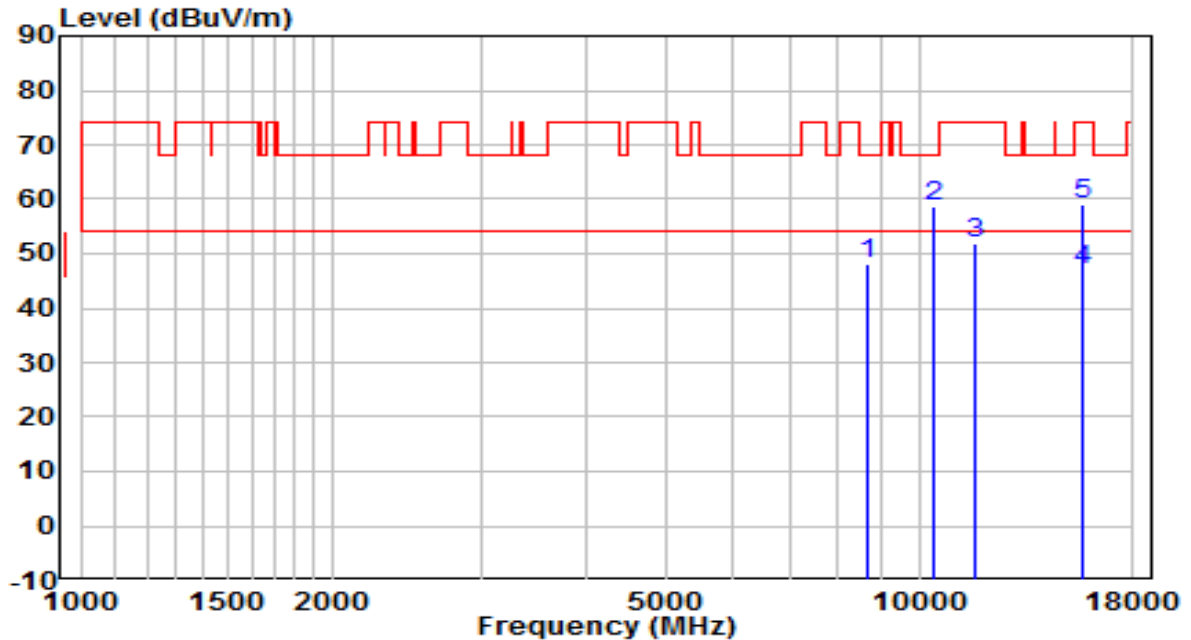

No	Frequency (MHz)	Reading (dBUV)	C.F (dB)	Measurement (dBUV/m)	Margin (dB)	Limit (dBUV/m)	Remark (QP/PK/AV)
1	8658.500	35.12	12.84	47.96	-20.24	68.20	Peak
2	10443.500	41.69	16.88	58.57	-9.63	68.20	Peak
3	11642.000	33.49	18.27	51.76	-22.24	74.00	Peak
4	* 15659.250	25.75	21.18	46.94	-7.06	54.00	Average
5	15662.500	37.77	21.18	58.94	-15.06	74.00	Peak

Note:

1. " *", means this data is the worst emission level.
2. C.F (Correction Factor) = Antenna Factor (dB)+ Cable Loss (dB)– Preamplifier(dB).
3. Measurement(dBUV/m) = Reading(dBUV) + C.F (Correction Factor).
- 4.The emission levels of other frequencies are very lower than the limit and not show in test report.

EUT	AX1800 Wi-Fi 6 Range Extender	Date of Test	2021-05-07
Factor	BBHA 9120D (1GHz~18GHz)	Temp. / Humidity	25.4°C/52%
Polarity	Horizontal	Site / Test Engineer	AC1 / Jay
Test Mode	Transmit by 802.11a at Channel 5240MHz	Test Voltage	AC 120V/60Hz

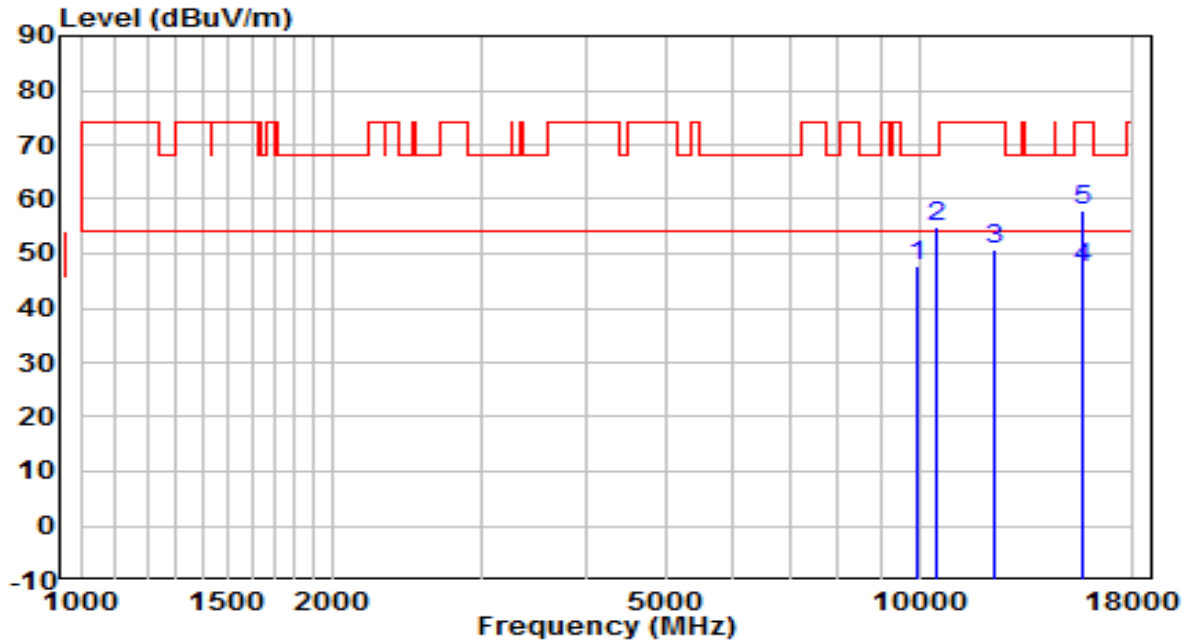

No	Frequency (MHz)	Reading (dBUV)	C.F (dB)	Measurement (dBUV/m)	Margin (dB)	Limit (dBUV/m)	Remark (QP/PK/AV)
1	9925.000	32.46	15.22	47.68	-20.52	68.20	Peak
2	10486.000	37.77	17.02	54.79	-13.41	68.20	Peak
3	12254.000	32.98	17.86	50.84	-23.16	74.00	Peak
4	* 15722.000	26.11	21.08	47.18	-6.82	54.00	Average
5	15722.000	36.75	21.08	57.83	-16.17	74.00	Peak

Note:

1. " *", means this data is the worst emission level.
2. C.F (Correction Factor) = Antenna Factor (dB)+ Cable Loss (dB)– Preamplifier(dB).
3. Measurement(dBUV/m) = Reading(dBUV) + C.F (Correction Factor).
- 4.The emission levels of other frequencies are very lower than the limit and not show in test report.

EUT	AX1800 Wi-Fi 6 Range Extender	Date of Test	2021-05-07
Factor	BBHA 9120D (1GHz~18GHz)	Temp. / Humidity	25.4°C/52%
Polarity	Vertical	Site / Test Engineer	AC1 / Jay
Test Mode	Transmit by 802.11a at Channel 5240MHz	Test Voltage	AC 120V/60Hz

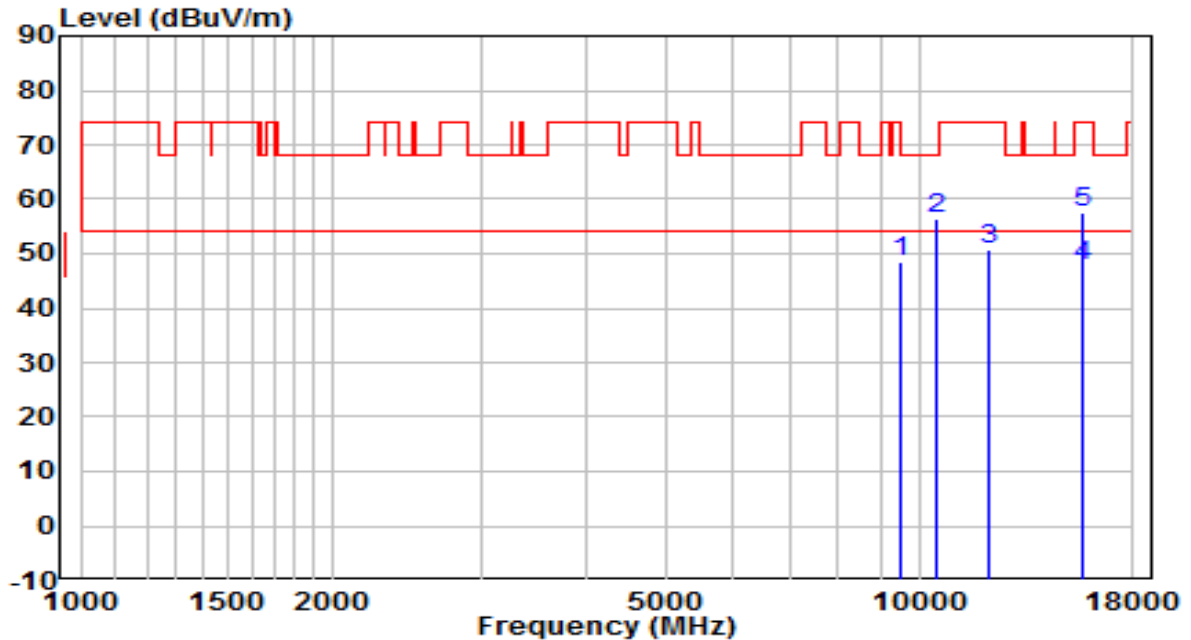

No	Frequency (MHz)	Reading (dBuV)	C.F (dB)	Measurement (dBuV/m)	Margin (dB)	Limit (dBuV/m)	Remark (QP/PK/AV)
1	9525.500	34.01	14.47	48.48	-19.72	68.20	Peak
2	10477.500	39.26	16.99	56.25	-11.95	68.20	Peak
3	12135.000	32.75	17.84	50.59	-23.41	74.00	Peak
4	* 15713.500	26.55	21.09	47.64	-6.36	54.00	Average
5	15713.500	36.43	21.09	57.52	-16.48	74.00	Peak

Note:

1. " *", means this data is the worst emission level.
2. C.F (Correction Factor) = Antenna Factor (dB)+ Cable Loss (dB)– Preamplifier(dB).
3. Measurement(dBuV/m) = Reading(dBuV) + C.F (Correction Factor).
- 4.The emission levels of other frequencies are very lower than the limit and not show in test report.

EUT	AX1800 Wi-Fi 6 Range Extender	Date of Test	2021-05-07
Factor	BBHA 9120D (1GHz~18GHz)	Temp. / Humidity	25.4°C/52%
Polarity	Horizontal	Site / Test Engineer	AC1 / Jay
Test Mode	Transmit by 802.11a at Channel 5260MHz	Test Voltage	AC 120V/60Hz

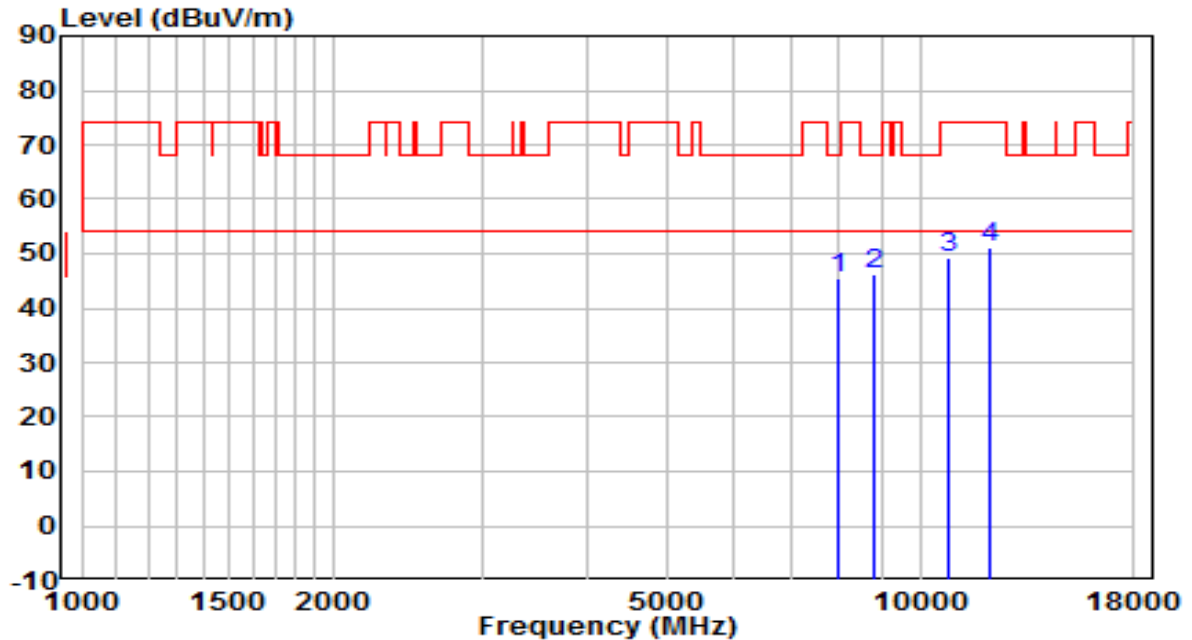

No	Frequency (MHz)	Reading (dBuV)	C.F (dB)	Measurement (dBuV/m)	Margin (dB)	Limit (dBuV/m)	Remark (QP/PK/AV)
1	8012.500	33.09	12.53	45.62	-22.58	68.20	Peak
2	* 8786.000	33.24	13.16	46.40	-21.80	68.20	Peak
3	10834.500	31.74	17.54	49.29	-24.71	74.00	Peak
4	12092.500	33.33	17.84	51.16	-22.84	74.00	Peak

Note:

- "*" means this data is the worst emission level.
- C.F (Correction Factor) = Antenna Factor (dB)+ Cable Loss (dB)– Preamplifier(dB).
- Measurement(dBuV/m) = Reading(dBuV) + C.F (Correction Factor).
- The emission levels of other frequencies are very lower than the limit and not show in test report.

EUT	AX1800 Wi-Fi 6 Range Extender	Date of Test	2021-05-07
Factor	BBHA 9120D (1GHz~18GHz)	Temp. / Humidity	25.4°C/52%
Polarity	Vertical	Site / Test Engineer	AC1 / Jay
Test Mode	Transmit by 802.11a at Channel 5260MHz	Test Voltage	AC 120V/60Hz

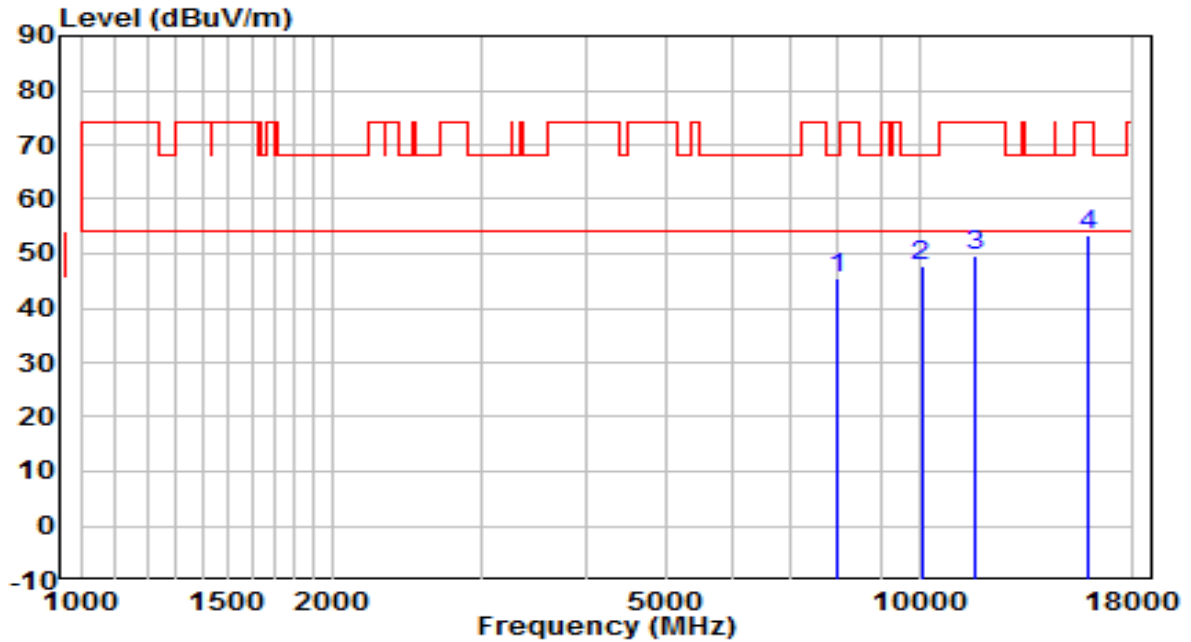

No	Frequency (MHz)	Reading (dBuV)	C.F (dB)	Measurement (dBuV/m)	Margin (dB)	Limit (dBuV/m)	Remark (QP/PK/AV)
1	7987.000	32.85	12.51	45.36	-22.84	68.20	Peak
2	* 10061.000	32.33	15.57	47.90	-20.30	68.20	Peak
3	11642.000	31.47	18.27	49.75	-24.25	74.00	Peak
4	15960.000	32.72	20.68	53.40	-20.60	74.00	Peak

Note:

- "*" means this data is the worst emission level.
- C.F (Correction Factor) = Antenna Factor (dB)+ Cable Loss (dB)– Preamplifier(dB).
- Measurement(dBuV/m) = Reading(dBuV) + C.F (Correction Factor).
- The emission levels of other frequencies are very lower than the limit and not show in test report.

EUT	AX1800 Wi-Fi 6 Range Extender	Date of Test	2021-05-07
Factor	BBHA 9120D (1GHz~18GHz)	Temp. / Humidity	25.4°C/52%
Polarity	Horizontal	Site / Test Engineer	AC1 / Jay
Test Mode	Transmit by 802.11a at Channel 5300MHz	Test Voltage	AC 120V/60Hz

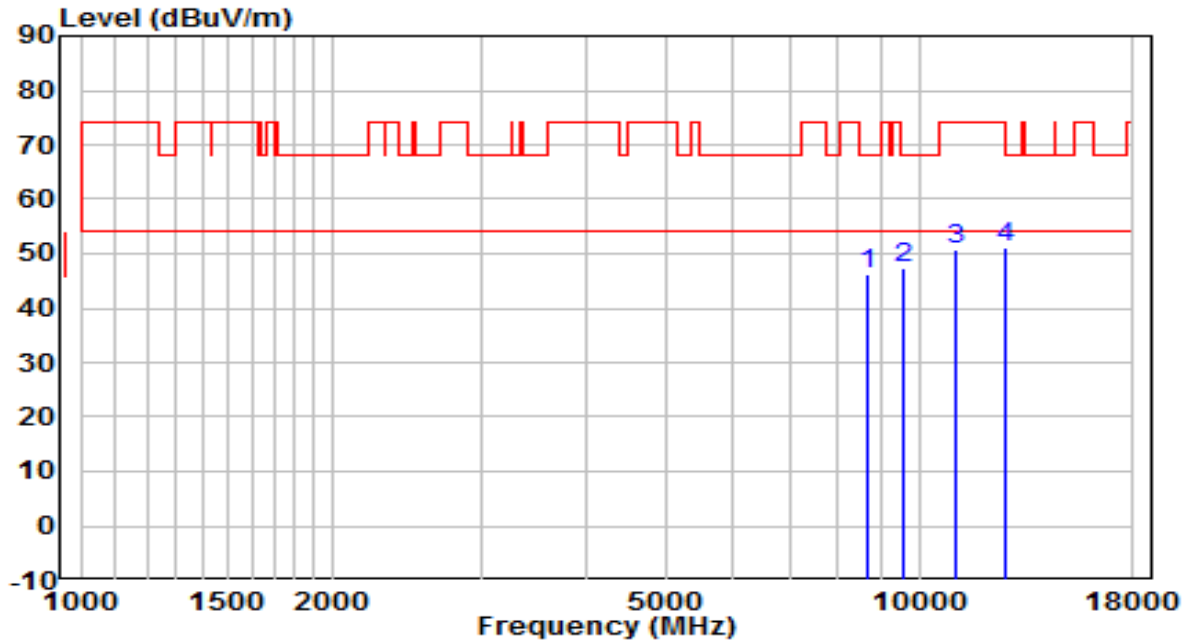

No	Frequency (MHz)	Reading (dBUV)	C.F (dB)	Measurement (dBUV/m)	Margin (dB)	Limit (dBUV/m)	Remark (QP/PK/AV)
1	8684.000	33.44	12.91	46.35	-21.85	68.20	Peak
2	* 9602.000	32.91	14.61	47.52	-20.68	68.20	Peak
3	11038.500	32.81	17.83	50.64	-23.36	74.00	Peak
4	12653.500	32.65	18.33	50.98	-23.02	74.00	Peak

Note:

- "*" means this data is the worst emission level.
- C.F (Correction Factor) = Antenna Factor (dB)+ Cable Loss (dB)– Preamplifier(dB).
- Measurement(dBUV/m) = Reading(dBUV) + C.F (Correction Factor).
- The emission levels of other frequencies are very lower than the limit and not show in test report.

EUT	AX1800 Wi-Fi 6 Range Extender	Date of Test	2021-05-07
Factor	BBHA 9120D (1GHz~18GHz)	Temp. / Humidity	25.4°C/52%
Polarity	Vertical	Site / Test Engineer	AC1 / Jay
Test Mode	Transmit by 802.11a at Channel 5300MHz	Test Voltage	AC 120V/60Hz

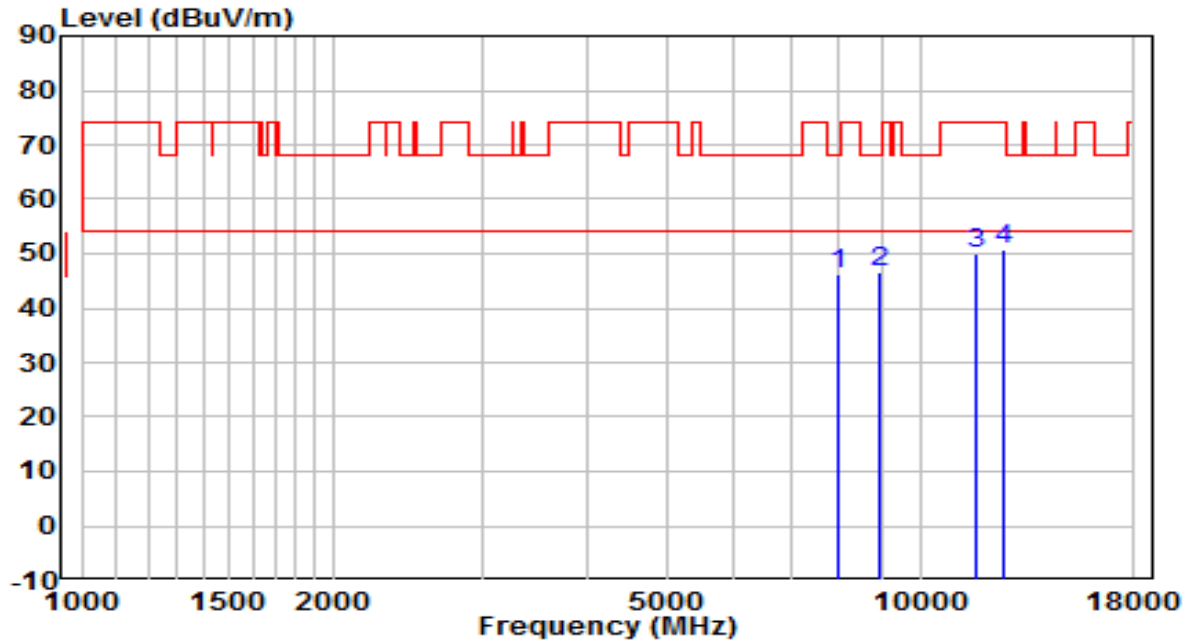

No	Frequency (MHz)	Reading (dBuV)	C.F (dB)	Measurement (dBuV/m)	Margin (dB)	Limit (dBuV/m)	Remark (QP/PK/AV)
1	8004.000	33.83	12.53	46.36	-21.84	68.20	Peak
2	* 8973.000	32.84	13.61	46.46	-21.74	68.20	Peak
3	11625.000	31.56	18.29	49.85	-24.15	74.00	Peak
4	12602.500	32.72	18.19	50.91	-23.09	74.00	Peak

Note:

- "*" means this data is the worst emission level.
- C.F (Correction Factor) = Antenna Factor (dB)+ Cable Loss (dB)– Preamplifier(dB).
- Measurement(dBuV/m) = Reading(dBuV) + C.F (Correction Factor).
- The emission levels of other frequencies are very lower than the limit and not show in test report.

EUT	AX1800 Wi-Fi 6 Range Extender	Date of Test	2021-05-07
Factor	BBHA 9120D (1GHz~18GHz)	Temp. / Humidity	25.4°C/52%
Polarity	Horizontal	Site / Test Engineer	AC1 / Jay
Test Mode	Transmit by 802.11a at Channel 5320MHz	Test Voltage	AC 120V/60Hz

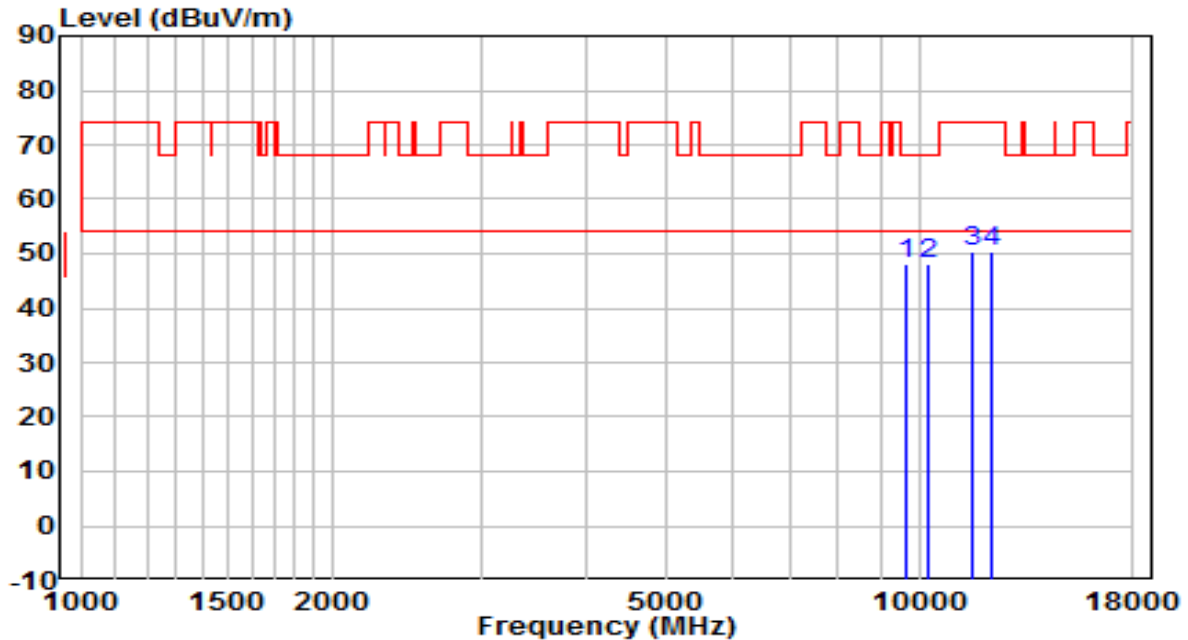

No	Frequency (MHz)	Reading (dBUV)	C.F (dB)	Measurement (dBUV/m)	Margin (dB)	Limit (dBUV/m)	Remark (QP/PK/AV)
1	* 9619.000	33.51	14.64	48.15	-20.05	68.20	Peak
2	10256.500	31.74	16.24	47.98	-20.22	68.20	Peak
3	11591.000	31.94	18.34	50.27	-23.73	74.00	Peak
4	12194.500	32.44	17.85	50.29	-23.71	74.00	Peak

Note:

1. " *", means this data is the worst emission level.
2. C.F (Correction Factor) = Antenna Factor (dB)+ Cable Loss (dB)– Preamplifier(dB).
3. Measurement(dBUV/m) = Reading(dBUV) + C.F (Correction Factor).
- 4.The emission levels of other frequencies are very lower than the limit and not show in test report.

EUT	AX1800 Wi-Fi 6 Range Extender	Date of Test	2021-05-07
Factor	BBHA 9120D (1GHz~18GHz)	Temp. / Humidity	25.4°C/52%
Polarity	Vertical	Site / Test Engineer	AC1 / Jay
Test Mode	Transmit by 802.11a at Channel 5320MHz	Test Voltage	AC 120V/60Hz

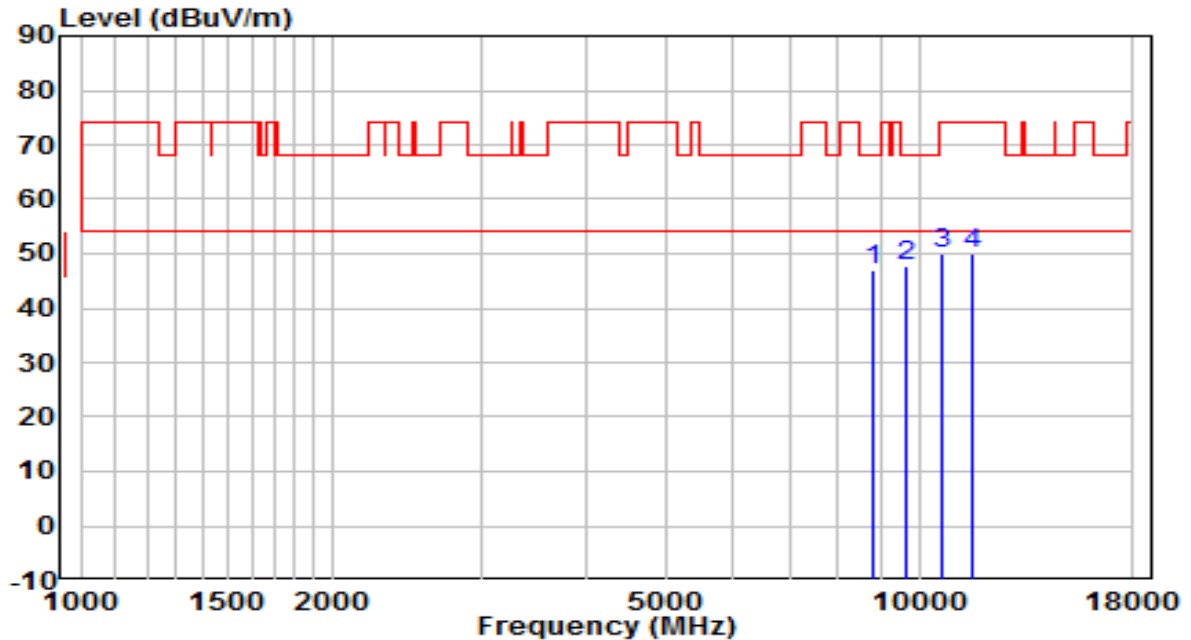

No	Frequency (MHz)	Reading (dBuV)	C.F (dB)	Measurement (dBuV/m)	Margin (dB)	Limit (dBuV/m)	Remark (QP/PK/AV)
1	8837.000	33.54	13.28	46.82	-21.38	68.20	Peak
2	* 9619.000	33.19	14.64	47.83	-20.37	68.20	Peak
3	10630.500	32.84	17.26	50.10	-23.90	74.00	Peak
4	11574.000	31.82	18.36	50.18	-23.82	74.00	Peak

Note:

- "*" , means this data is the worst emission level.
- C.F (Correction Factor) = Antenna Factor (dB)+ Cable Loss (dB)– Preamplifier(dB).
- Measurement(dBuV/m) = Reading(dBuV) + C.F (Correction Factor).
- The emission levels of other frequencies are very lower than the limit and not show in test report.

EUT	AX1800 Wi-Fi 6 Range Extender	Date of Test	2021-05-07
Factor	BBHA 9120D (1GHz~18GHz)	Temp. / Humidity	25.4°C/52%
Polarity	Horizontal	Site / Test Engineer	AC1 / Jay
Test Mode	Transmit by 802.11a at Channel 5500MHz	Test Voltage	AC 120V/60Hz

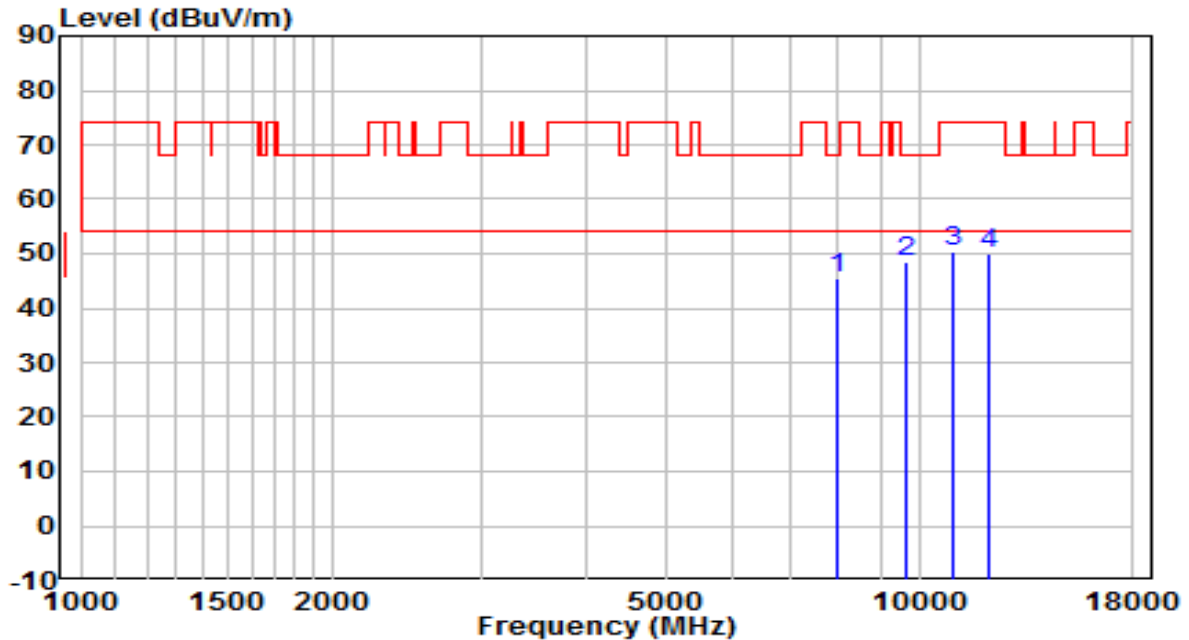

No	Frequency (MHz)	Reading (dBuV)	C.F (dB)	Measurement (dBuV/m)	Margin (dB)	Limit (dBuV/m)	Remark (QP/PK/AV)
1	7987.000	33.01	12.51	45.52	-22.68	68.20	Peak
2	* 9661.500	33.81	14.72	48.53	-19.67	68.20	Peak
3	10979.000	32.48	17.75	50.23	-23.77	74.00	Peak
4	12101.000	32.26	17.84	50.10	-23.90	74.00	Peak

Note:

1. " *", means this data is the worst emission level.
2. C.F (Correction Factor) = Antenna Factor (dB)+ Cable Loss (dB)– Preamplifier(dB).
3. Measurement(dBuV/m) = Reading(dBuV) + C.F (Correction Factor).
- 4.The emission levels of other frequencies are very lower than the limit and not show in test report.

EUT	AX1800 Wi-Fi 6 Range Extender	Date of Test	2021-05-07
Factor	BBHA 9120D (1GHz~18GHz)	Temp. / Humidity	25.4°C/52%
Polarity	Vertical	Site / Test Engineer	AC1 / Jay
Test Mode	Transmit by 802.11a at Channel 5500MHz	Test Voltage	AC 120V/60Hz

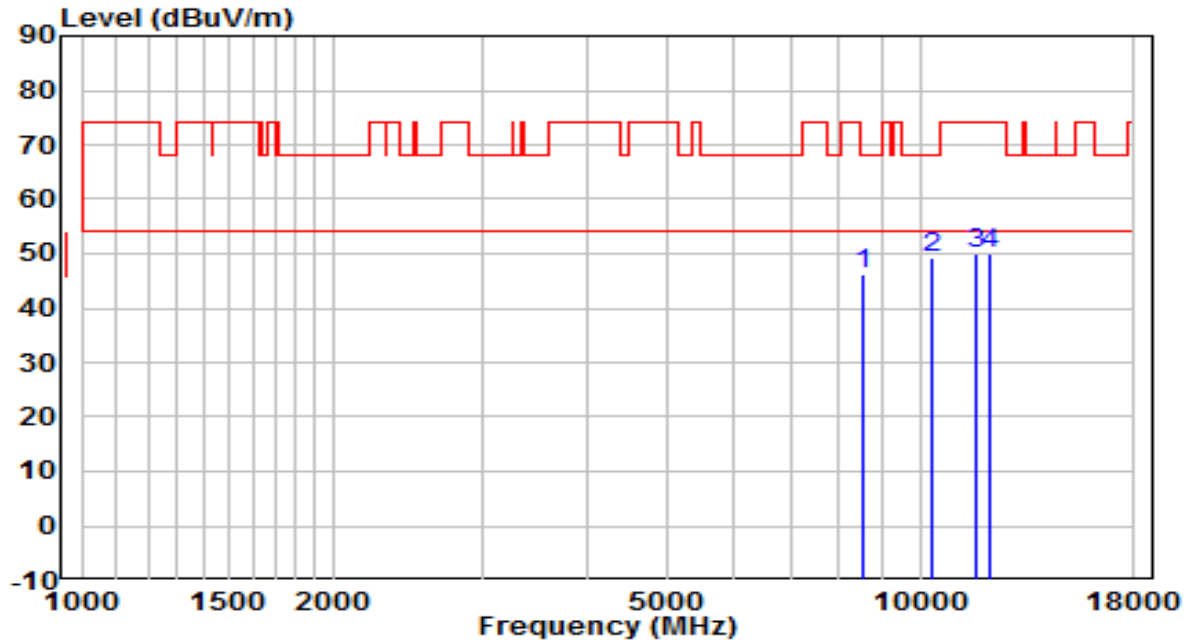

No	Frequency (MHz)	Reading (dBuV)	C.F (dB)	Measurement (dBuV/m)	Margin (dB)	Limit (dBuV/m)	Remark (QP/PK/AV)
1	8548.000	33.83	12.57	46.41	-21.79	68.20	Peak
2	* 10307.500	32.83	16.41	49.25	-18.95	68.20	Peak
3	11659.000	31.93	18.25	50.18	-23.82	74.00	Peak
4	12118.000	32.09	17.84	49.93	-24.07	74.00	Peak

Note:

- "*" means this data is the worst emission level.
- C.F (Correction Factor) = Antenna Factor (dB)+ Cable Loss (dB)– Preamplifier(dB).
- Measurement(dBuV/m) = Reading(dBuV) + C.F (Correction Factor).
- The emission levels of other frequencies are very lower than the limit and not show in test report.

EUT	AX1800 Wi-Fi 6 Range Extender	Date of Test	2021-05-07
Factor	BBHA 9120D (1GHz~18GHz)	Temp. / Humidity	25.4°C/52%
Polarity	Horizontal	Site / Test Engineer	AC1 / Jay
Test Mode	Transmit by 802.11a at Channel 5580MHz	Test Voltage	AC 120V/60Hz

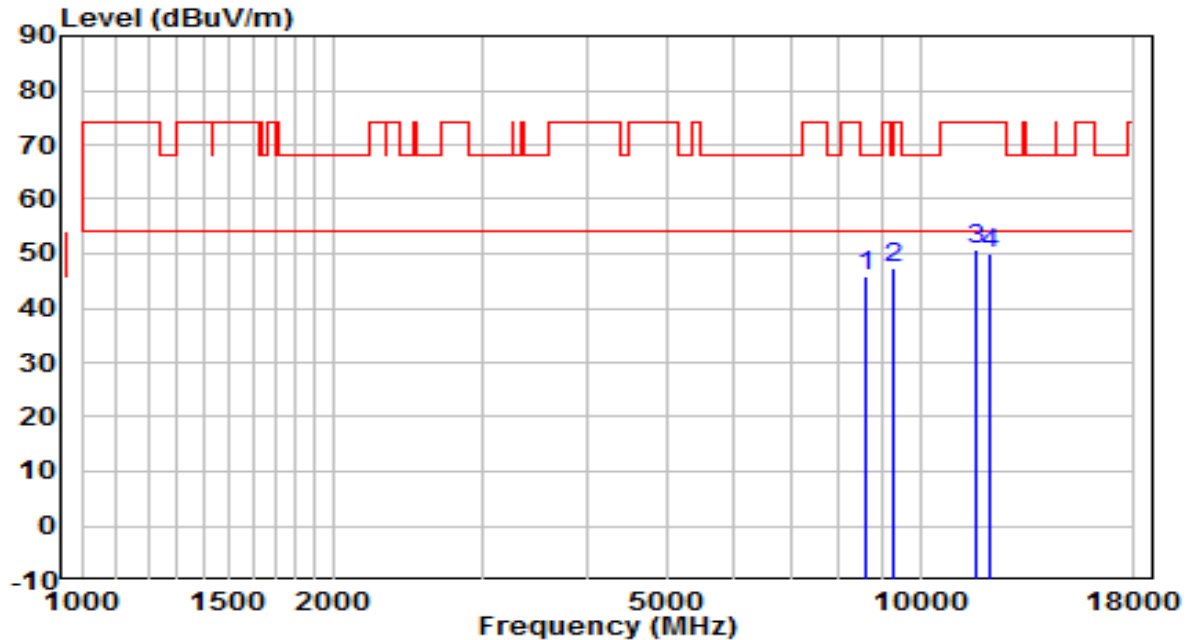

No	Frequency (MHz)	Reading (dBuV)	C.F (dB)	Measurement (dBuV/m)	Margin (dB)	Limit (dBuV/m)	Remark (QP/PK/AV)
1	8607.500	33.23	12.72	45.95	-22.25	68.20	Peak
2	* 9279.000	33.44	14.09	47.53	-20.67	68.20	Peak
3	11642.000	32.44	18.27	50.71	-23.29	74.00	Peak
4	12152.000	32.13	17.85	49.97	-24.03	74.00	Peak

Note:

- "*" , means this data is the worst emission level.
- C.F (Correction Factor) = Antenna Factor (dB)+ Cable Loss (dB)– Preamplifier(dB).
- Measurement(dBuV/m) = Reading(dBuV) + C.F (Correction Factor).
- The emission levels of other frequencies are very lower than the limit and not show in test report.

EUT	AX1800 Wi-Fi 6 Range Extender	Date of Test	2021-05-07
Factor	BBHA 9120D (1GHz~18GHz)	Temp. / Humidity	25.4°C/52%
Polarity	Vertical	Site / Test Engineer	AC1 / Jay
Test Mode	Transmit by 802.11a at Channel 5580MHz	Test Voltage	AC 120V/60Hz

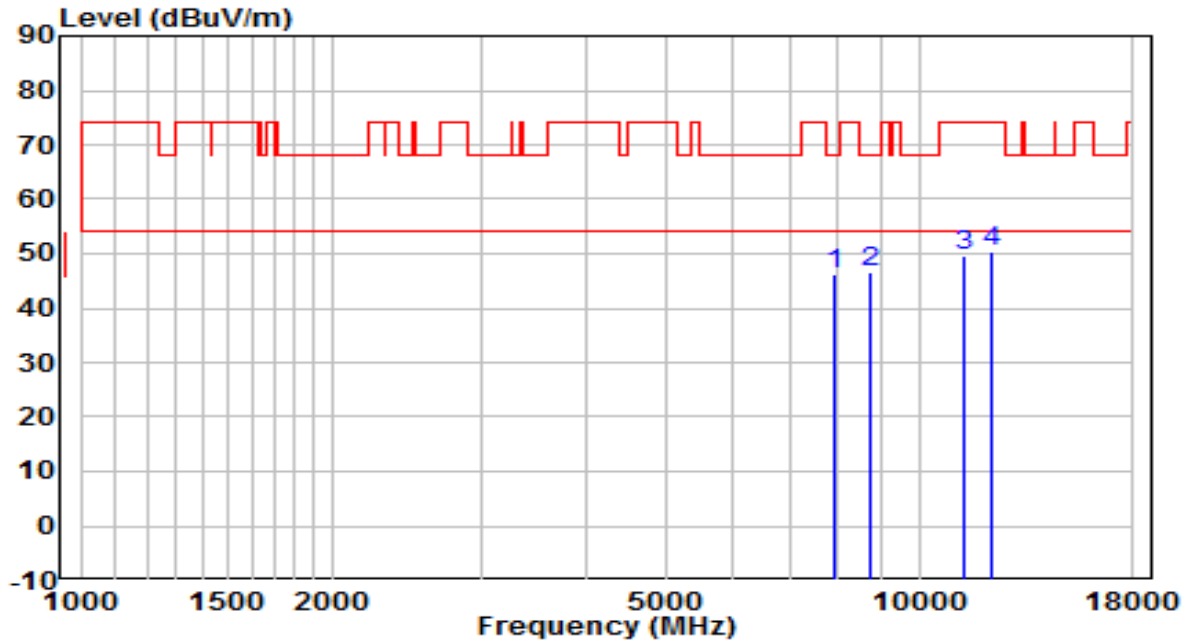

No	Frequency (MHz)	Reading (dBUV)	C.F (dB)	Measurement (dBUV/m)	Margin (dB)	Limit (dBUV/m)	Remark (QP/PK/AV)
1	7910.500	33.74	12.38	46.13	-22.07	68.20	Peak
2	* 8726.500	33.78	13.01	46.79	-21.41	68.20	Peak
3	11310.500	31.27	18.20	49.47	-24.53	74.00	Peak
4	12245.500	32.45	17.86	50.31	-23.69	74.00	Peak

Note:

- "*" means this data is the worst emission level.
- C.F (Correction Factor) = Antenna Factor (dB)+ Cable Loss (dB)– Preamplifier(dB).
- Measurement(dBUV/m) = Reading(dBUV) + C.F (Correction Factor).
- The emission levels of other frequencies are very lower than the limit and not show in test report.

EUT	AX1800 Wi-Fi 6 Range Extender	Date of Test	2021-05-07
Factor	BBHA 9120D (1GHz~18GHz)	Temp. / Humidity	25.4°C/52%
Polarity	Horizontal	Site / Test Engineer	AC1 / Jay
Test Mode	Transmit by 802.11a at Channel 5700MHz	Test Voltage	AC 120V/60Hz

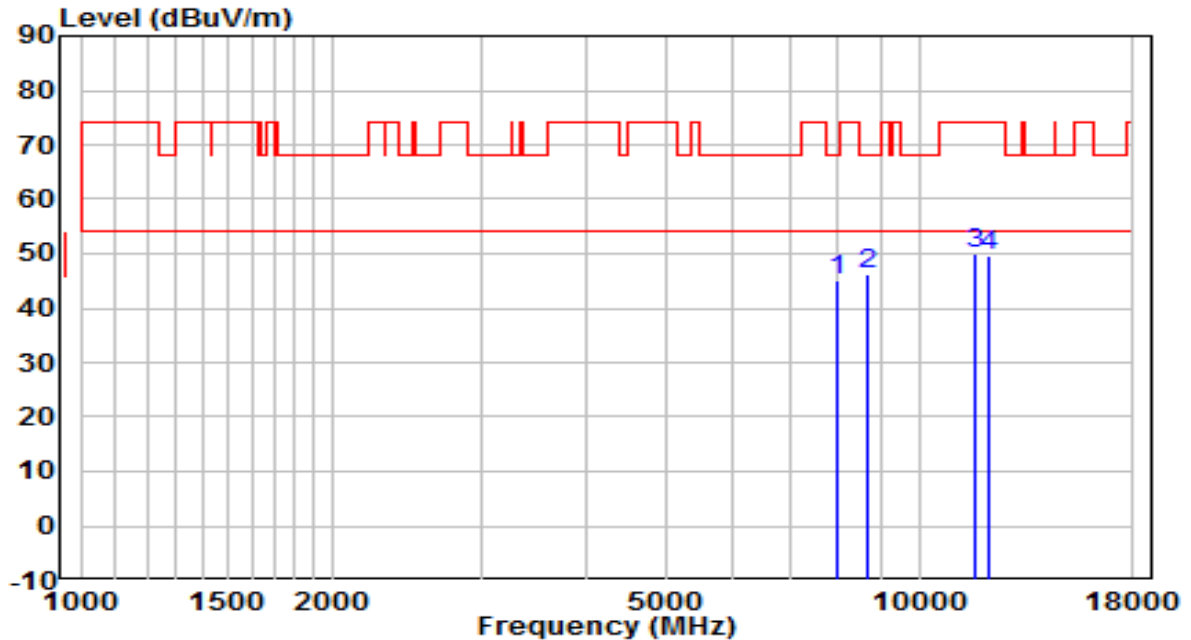

No	Frequency (MHz)	Reading (dBUV)	C.F (dB)	Measurement (dBUV/m)	Margin (dB)	Limit (dBUV/m)	Remark (QP/PK/AV)
1	7995.500	32.70	12.52	45.22	-22.98	68.20	Peak
2	* 8692.500	33.33	12.93	46.25	-21.95	68.20	Peak
3	11642.000	31.85	18.27	50.12	-23.88	74.00	Peak
4	12135.000	31.79	17.84	49.63	-24.37	74.00	Peak

Note:

- "*" means this data is the worst emission level.
- C.F (Correction Factor) = Antenna Factor (dB)+ Cable Loss (dB)– Preamplifier(dB).
- Measurement(dBUV/m) = Reading(dBUV) + C.F (Correction Factor).
- The emission levels of other frequencies are very lower than the limit and not show in test report.

EUT	AX1800 Wi-Fi 6 Range Extender	Date of Test	2021-05-07
Factor	BBHA 9120D (1GHz~18GHz)	Temp. / Humidity	25.4°C/52%
Polarity	Vertical	Site / Test Engineer	AC1 / Jay
Test Mode	Transmit by 802.11a at Channel 5700MHz	Test Voltage	AC 120V/60Hz

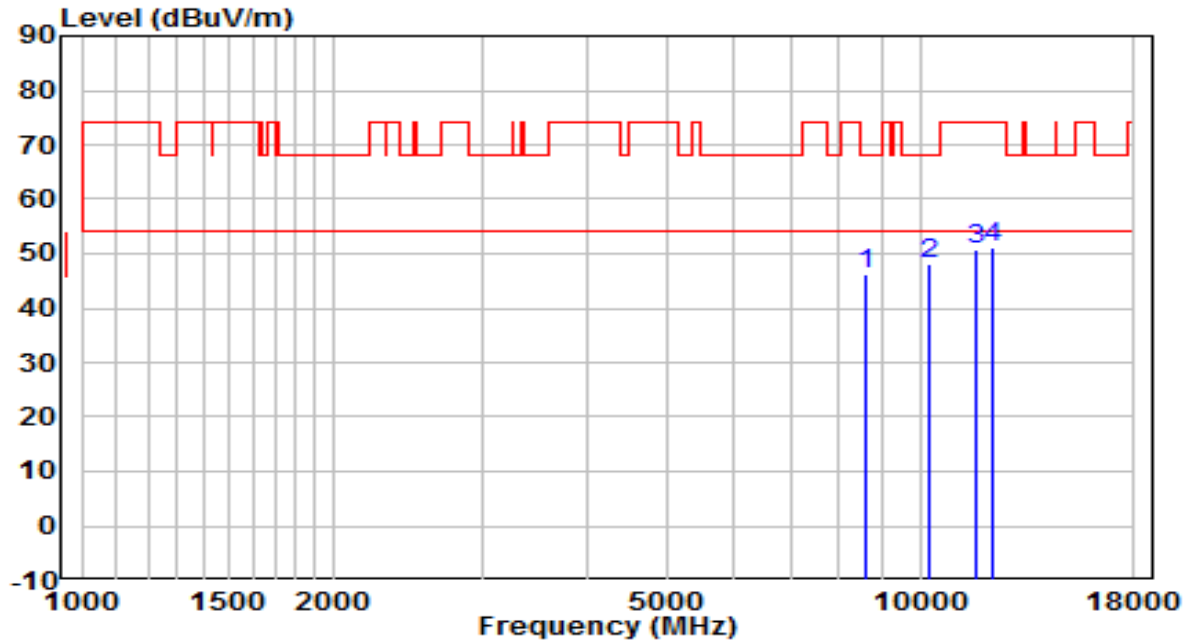

No	Frequency (MHz)	Reading (dBuV)	C.F (dB)	Measurement (dBuV/m)	Margin (dB)	Limit (dBuV/m)	Remark (QP/PK/AV)
1	8607.500	33.65	12.72	46.37	-21.83	68.20	Peak
2	* 10265.000	32.03	16.27	48.29	-19.91	68.20	Peak
3	11642.000	32.36	18.27	50.63	-23.37	74.00	Peak
4	12169.000	33.30	17.85	51.15	-22.85	74.00	Peak

Note:

1. " *", means this data is the worst emission level.
2. C.F (Correction Factor) = Antenna Factor (dB)+ Cable Loss (dB)– Preamplifier(dB).
3. Measurement(dBuV/m) = Reading(dBuV) + C.F (Correction Factor).
- 4.The emission levels of other frequencies are very lower than the limit and not show in test report.

EUT	AX1800 Wi-Fi 6 Range Extender	Date of Test	2021-05-07
Factor	BBHA 9120D (1GHz~18GHz)	Temp. / Humidity	25.4°C/52%
Polarity	Horizontal	Site / Test Engineer	AC1 / Jay
Test Mode	Transmit by 802.11a at Channel 5745MHz	Test Voltage	AC 120V/60Hz

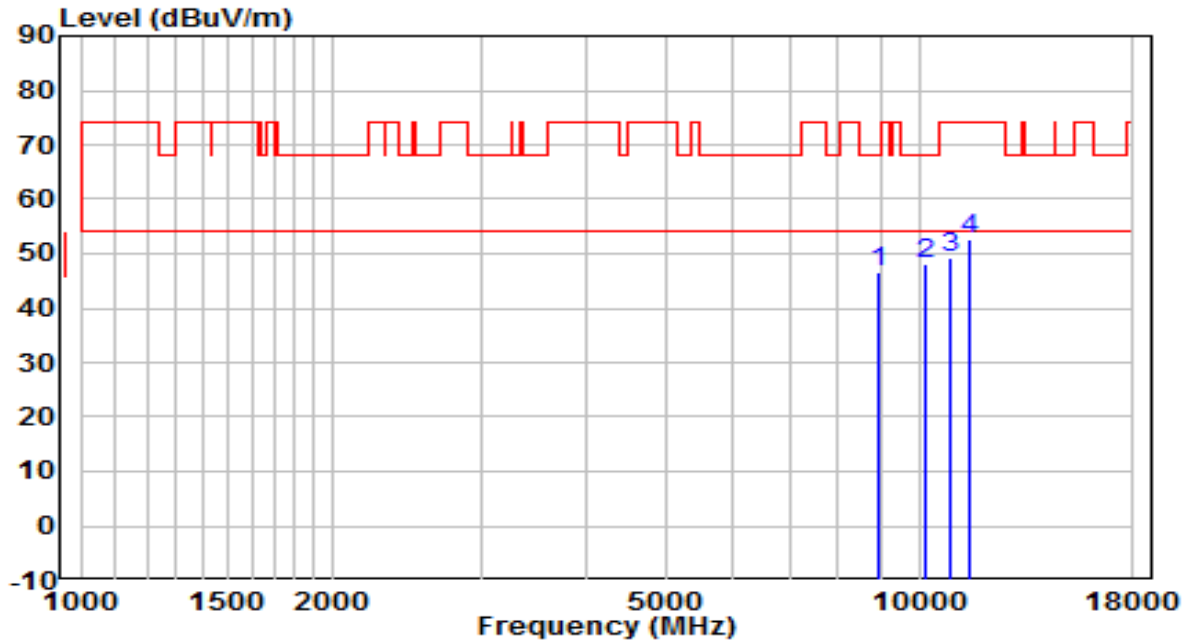

No	Frequency (MHz)	Reading (dBUV)	C.F (dB)	Measurement (dBUV/m)	Margin (dB)	Limit (dBUV/m)	Remark (QP/PK/AV)
1	8964.500	33.06	13.59	46.65	-21.55	68.20	Peak
2	* 10154.500	32.08	15.89	47.97	-20.23	68.20	Peak
3	10911.000	31.63	17.65	49.28	-24.72	74.00	Peak
4	11489.000	34.27	18.44	52.70	-21.30	74.00	Peak

Note:

1. " *", means this data is the worst emission level.
2. C.F (Correction Factor) = Antenna Factor (dB)+ Cable Loss (dB)– Preamplifier(dB).
3. Measurement(dBUV/m) = Reading(dBUV) + C.F (Correction Factor).
- 4.The emission levels of other frequencies are very lower than the limit and not show in test report.

EUT	AX1800 Wi-Fi 6 Range Extender	Date of Test	2021-05-07
Factor	BBHA 9120D (1GHz~18GHz)	Temp. / Humidity	25.4°C/52%
Polarity	Vertical	Site / Test Engineer	AC1 / Jay
Test Mode	Transmit by 802.11a at Channel 5745MHz	Test Voltage	AC 120V/60Hz

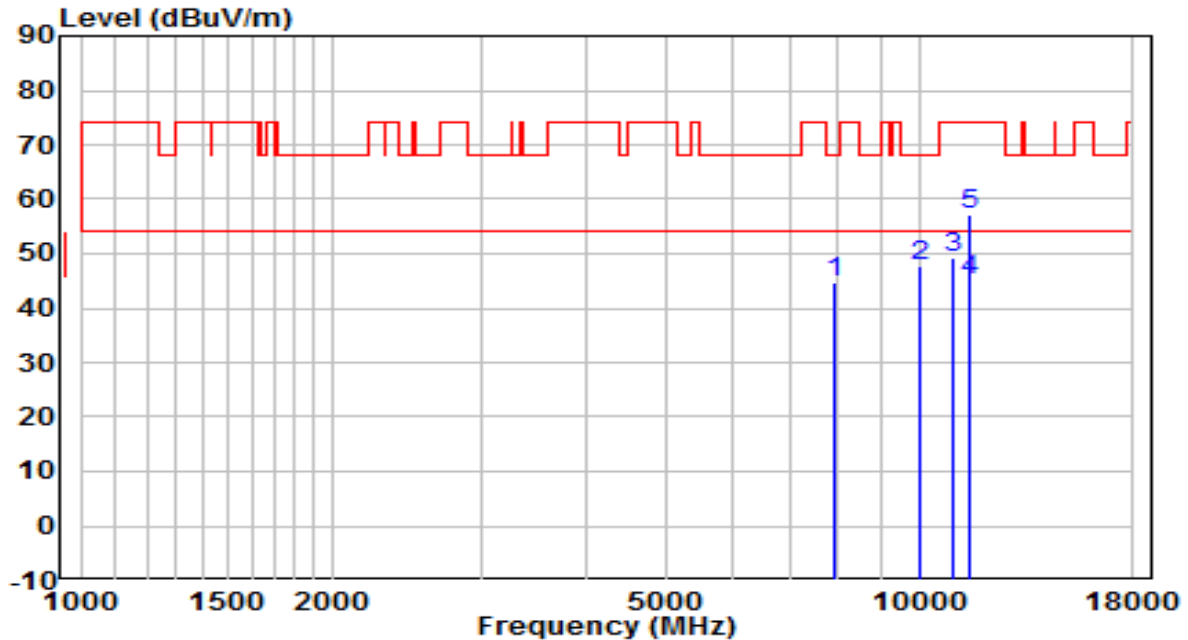

No	Frequency (MHz)	Reading (dBuV)	C.F (dB)	Measurement (dBuV/m)	Margin (dB)	Limit (dBuV/m)	Remark (QP/PK/AV)
1	7944.500	32.42	12.44	44.86	-23.34	68.20	Peak
2	10052.500	32.08	15.54	47.62	-20.58	68.20	Peak
3	10945.000	31.47	17.70	49.17	-24.83	74.00	Peak
4	* 11491.050	26.75	18.44	45.18	-8.82	54.00	Average
5	11497.500	38.64	18.45	57.09	-16.91	74.00	Peak

Note:

1. " *", means this data is the worst emission level.
2. C.F (Correction Factor) = Antenna Factor (dB)+ Cable Loss (dB)– Preamplifier(dB).
3. Measurement(dBuV/m) = Reading(dBuV) + C.F (Correction Factor).
- 4.The emission levels of other frequencies are very lower than the limit and not show in test report.

EUT	AX1800 Wi-Fi 6 Range Extender	Date of Test	2021-05-07
Factor	BBHA 9120D (1GHz~18GHz)	Temp. / Humidity	25.4°C/52%
Polarity	Horizontal	Site / Test Engineer	AC1 / Jay
Test Mode	Transmit by 802.11a at Channel 5785MHz	Test Voltage	AC 120V/60Hz

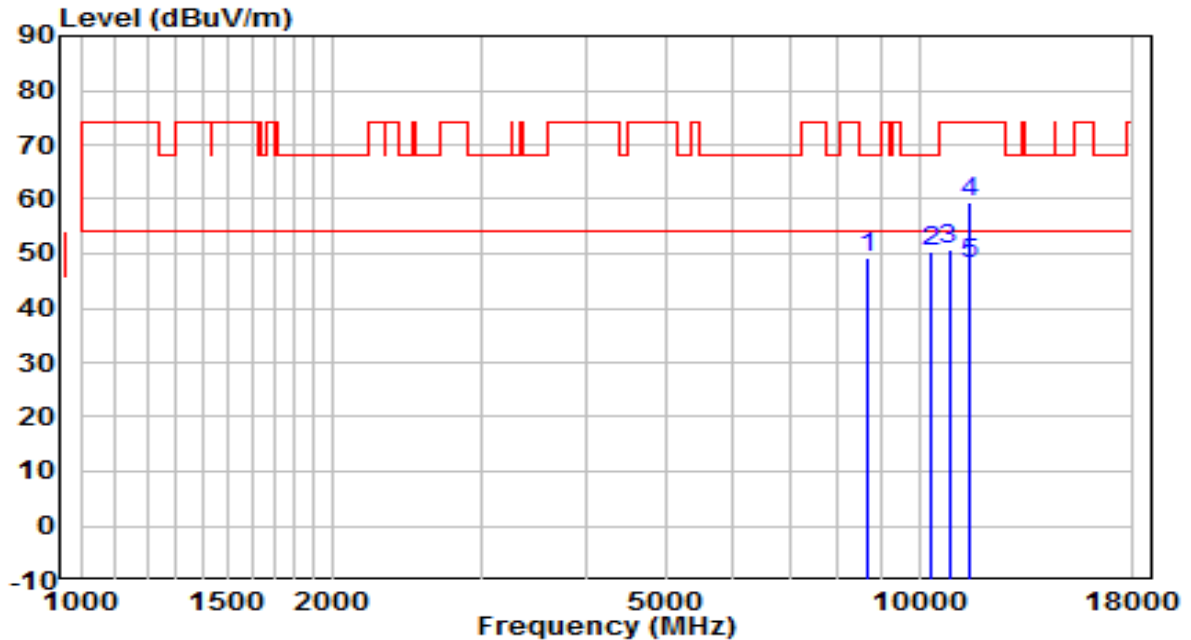

No	Frequency (MHz)	Reading (dBuV)	C.F (dB)	Measurement (dBuV/m)	Margin (dB)	Limit (dBuV/m)	Remark (QP/PK/AV)
1	8650.000	36.28	12.82	49.10	-19.10	68.20	Peak
2	10307.500	33.97	16.41	50.38	-17.82	68.20	Peak
3	10851.500	33.32	17.57	50.89	-23.11	74.00	Peak
4	11489.000	41.07	18.44	59.50	-14.50	74.00	Peak
5	* 11489.620	29.69	18.44	48.13	-5.87	54.00	Average

Note:

1. " *", means this data is the worst emission level.
2. C.F (Correction Factor) = Antenna Factor (dB)+ Cable Loss (dB)– Preamplifier(dB).
3. Measurement(dBuV/m) = Reading(dBuV) + C.F (Correction Factor).
- 4.The emission levels of other frequencies are very lower than the limit and not show in test report.

EUT	AX1800 Wi-Fi 6 Range Extender	Date of Test	2021-05-07
Factor	BBHA 9120D (1GHz~18GHz)	Temp. / Humidity	25.4°C/52%
Polarity	Vertical	Site / Test Engineer	AC1 / Jay
Test Mode	Transmit by 802.11a at Channel 5785MHz	Test Voltage	AC 120V/60Hz

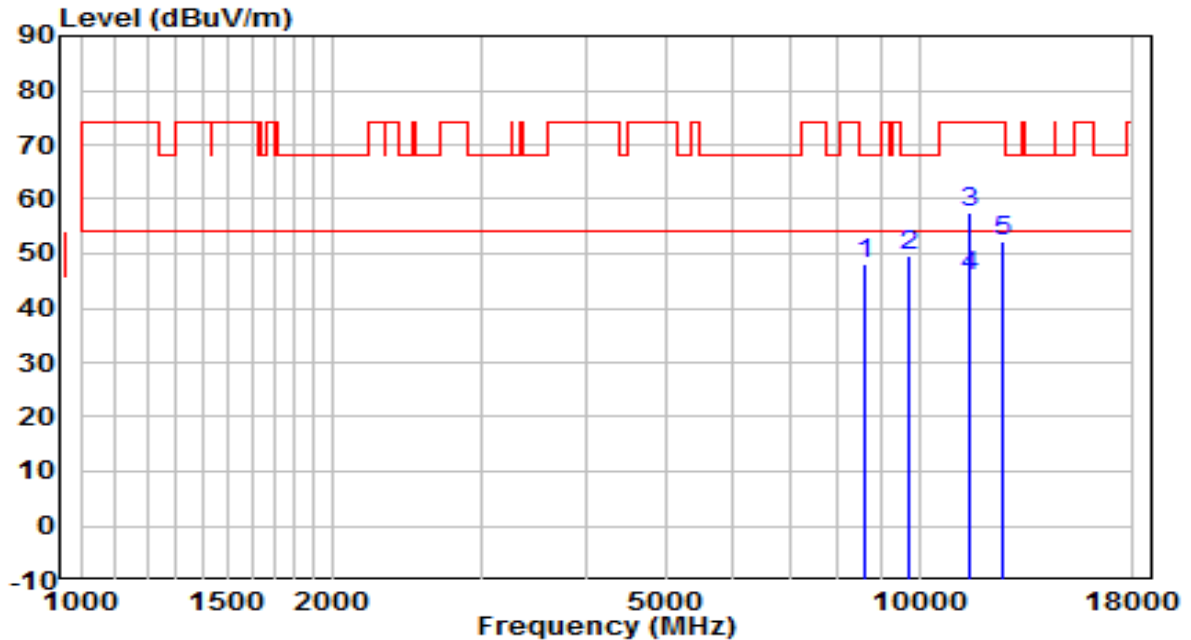

No	Frequency (MHz)	Reading (dBUV)	C.F (dB)	Measurement (dBUV/m)	Margin (dB)	Limit (dBUV/m)	Remark (QP/PK/AV)
1	8599.000	35.31	12.70	48.01	-20.19	68.20	Peak
2	9695.500	34.87	14.79	49.65	-18.55	68.20	Peak
3	11480.500	39.21	18.42	57.64	-16.36	74.00	Peak
4	* 11480.720	27.41	18.42	45.83	-8.17	54.00	Average
5	12611.000	33.94	18.21	52.15	-21.85	74.00	Peak

Note:

- "*", means this data is the worst emission level.
- C.F (Correction Factor) = Antenna Factor (dB)+ Cable Loss (dB)– Preamplifier(dB).
- Measurement(dBUV/m) = Reading(dBUV) + C.F (Correction Factor).
- The emission levels of other frequencies are very lower than the limit and not show in test report.

EUT	AX1800 Wi-Fi 6 Range Extender	Date of Test	2021-05-07
Factor	BBHA 9120D (1GHz~18GHz)	Temp. / Humidity	25.4°C/52%
Polarity	Horizontal	Site / Test Engineer	AC1 / Jay
Test Mode	Transmit by 802.11a at Channel 5825MHz	Test Voltage	AC 120V/60Hz

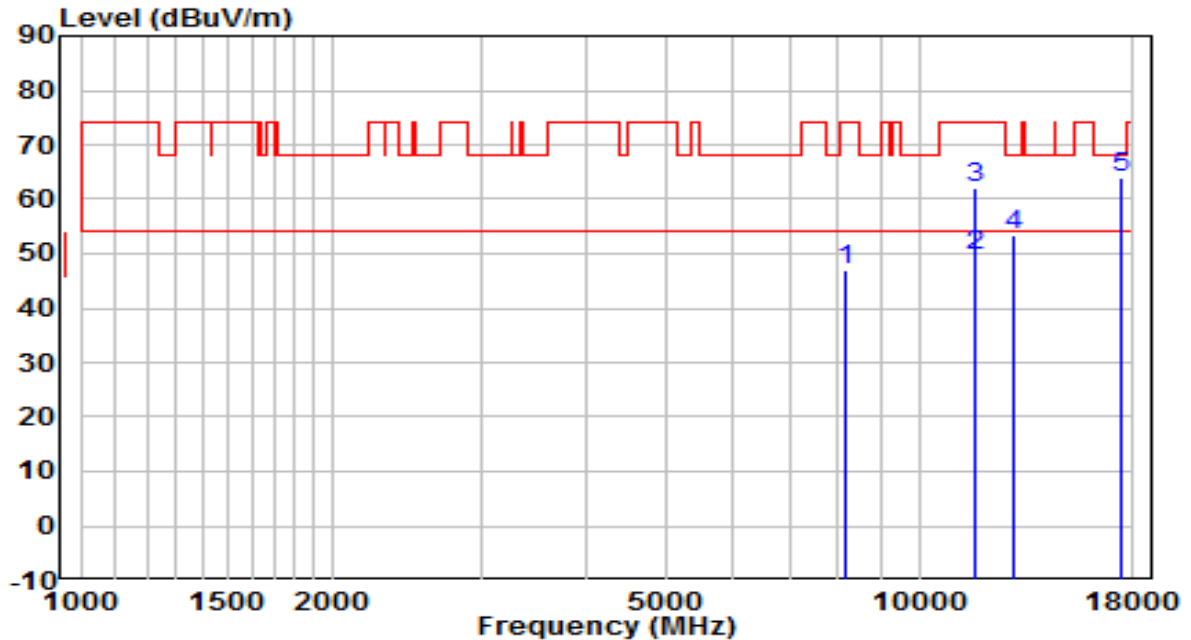

No	Frequency (MHz)	Reading (dBUV)	C.F (dB)	Measurement (dBUV/m)	Margin (dB)	Limit (dBUV/m)	Remark (QP/PK/AV)
1	8174.000	34.65	12.50	47.15	-26.85	74.00	Peak
2	* 11648.500	31.40	18.26	49.67	-4.33	54.00	Average
3	11650.500	43.90	18.26	62.16	-11.84	74.00	Peak
4	13002.000	33.95	19.30	53.25	-14.95	68.20	Peak
5	17473.000	33.42	30.37	63.79	-4.41	68.20	Peak

Note:

1. " *", means this data is the worst emission level.
2. C.F (Correction Factor) = Antenna Factor (dB)+ Cable Loss (dB)– Preamplifier(dB).
3. Measurement(dBUV/m) = Reading(dBUV) + C.F (Correction Factor).
- 4.The emission levels of other frequencies are very lower than the limit and not show in test report.

EUT	AX1800 Wi-Fi 6 Range Extender	Date of Test	2021-05-07
Factor	BBHA 9120D (1GHz~18GHz)	Temp. / Humidity	25.4°C/52%
Polarity	Vertical	Site / Test Engineer	AC1 / Jay
Test Mode	Transmit by 802.11a at Channel 5825MHz	Test Voltage	AC 120V/60Hz

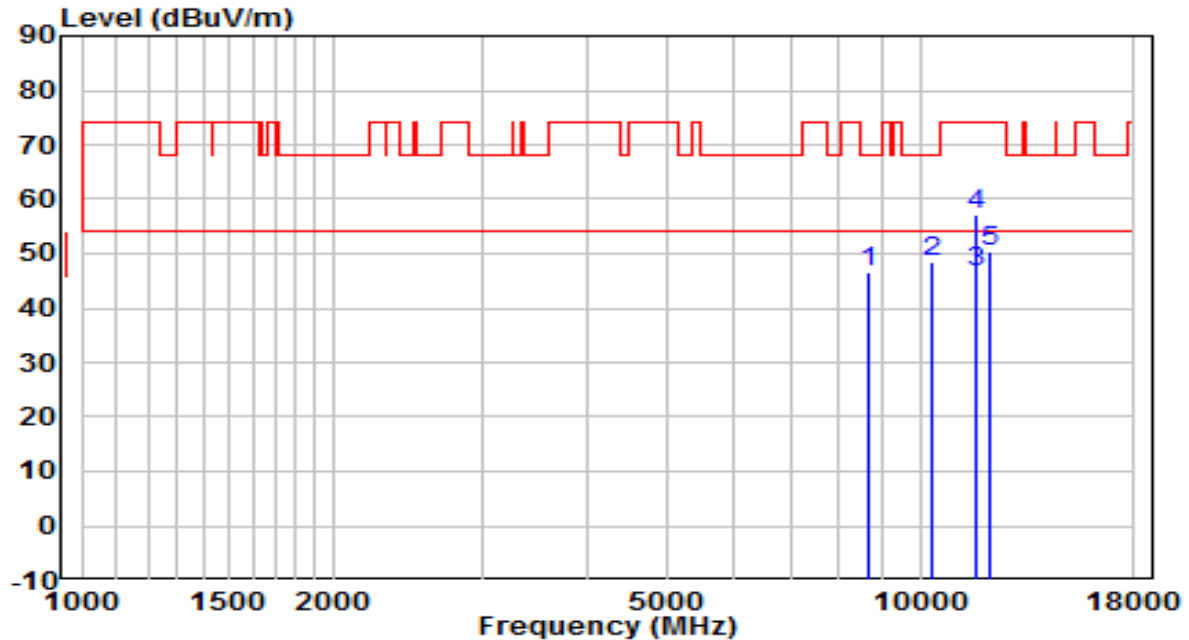

No	Frequency (MHz)	Reading (dBuV)	C.F (dB)	Measurement (dBuV/m)	Margin (dB)	Limit (dBuV/m)	Remark (QP/PK/AV)
1	8701.000	33.54	12.95	46.49	-21.71	68.20	Peak
2	10307.500	32.19	16.41	48.60	-19.60	68.20	Peak
3	* 11650.500	28.25	18.26	46.51	-7.49	54.00	Average
4	11650.500	38.93	18.26	57.19	-16.81	74.00	Peak
5	12143.500	32.71	17.84	50.56	-23.44	74.00	Peak

Note:

1. " *", means this data is the worst emission level.
2. C.F (Correction Factor) = Antenna Factor (dB)+ Cable Loss (dB)– Preamplifier(dB).
3. Measurement(dBuV/m) = Reading(dBuV) + C.F (Correction Factor).
- 4.The emission levels of other frequencies are very lower than the limit and not show in test report.

EUT	AX1800 Wi-Fi 6 Range Extender	Date of Test	2021-05-07
Factor	BBHA 9120D (1GHz~18GHz)	Temp. / Humidity	25.4°C/52%
Polarity	Horizontal	Site / Test Engineer	AC1 / Jay
Test Mode	Transmit by 802.11ac-VHT20 at Channel 5180MHz	Test Voltage	AC 120V/60Hz

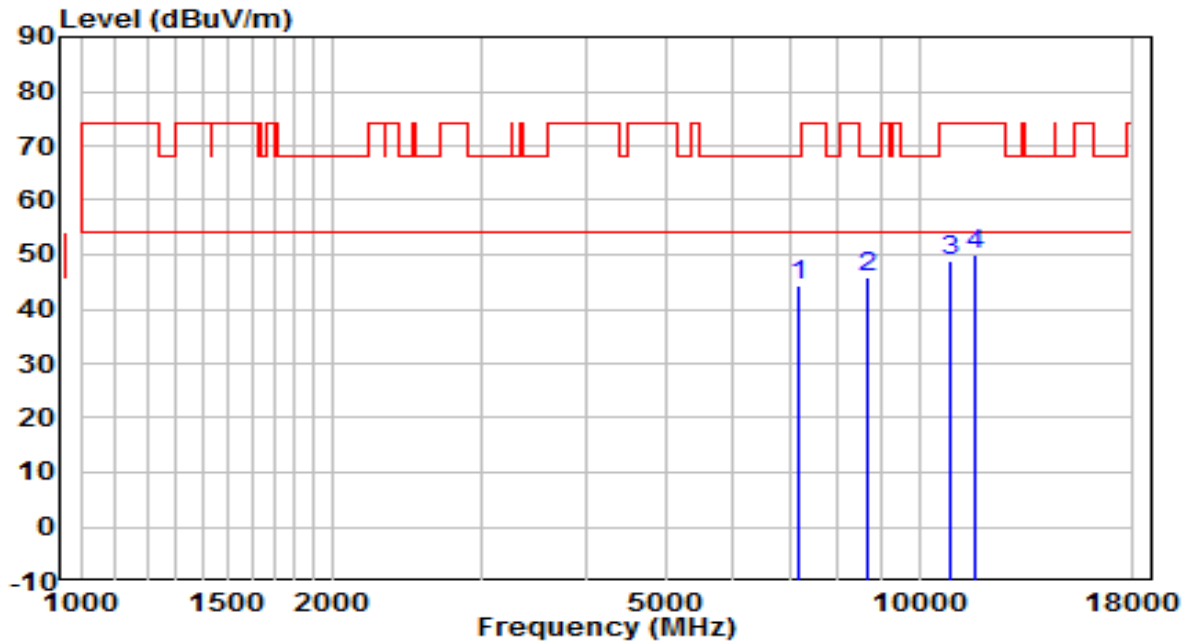

No	Frequency (MHz)	Reading (dBuV)	C.F (dB)	Measurement (dBuV/m)	Margin (dB)	Limit (dBuV/m)	Remark (QP/PK/AV)
1	7162.500	33.76	10.76	44.52	-23.68	68.20	Peak
2	* 8684.000	33.12	12.91	46.03	-22.17	68.20	Peak
3	10902.500	31.33	17.64	48.97	-25.03	74.00	Peak
4	11642.000	31.90	18.27	50.17	-23.83	74.00	Peak

Note:

- "*", means this data is the worst emission level.
- C.F (Correction Factor) = Antenna Factor (dB)+ Cable Loss (dB)– Preamplifier(dB).
- Measurement(dBuV/m) = Reading(dBuV) + C.F (Correction Factor).
- The emission levels of other frequencies are very lower than the limit and not show in test report.

EUT	AX1800 Wi-Fi 6 Range Extender	Date of Test	2021-05-07
Factor	BBHA 9120D (1GHz~18GHz)	Temp. / Humidity	25.4°C/52%
Polarity	Vertical	Site / Test Engineer	AC1 / Jay
Test Mode	Transmit by 802.11ac-VHT20 at Channel 5180MHz	Test Voltage	AC 120V/60Hz

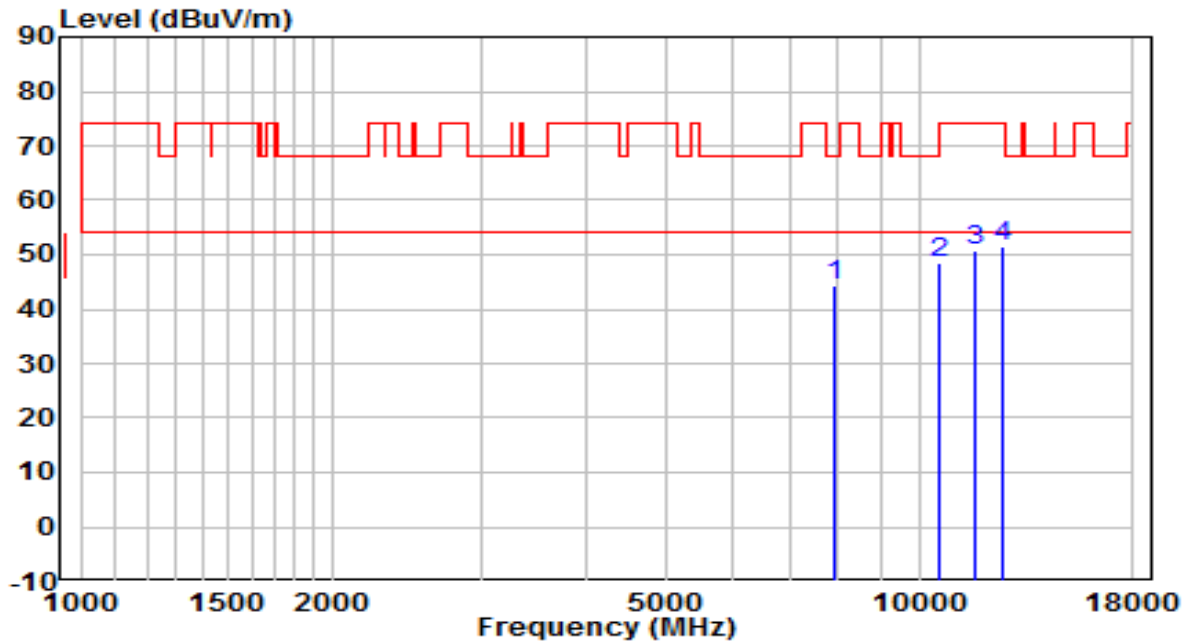

No	Frequency (MHz)	Reading (dBUV)	C.F (dB)	Measurement (dBUV/m)	Margin (dB)	Limit (dBUV/m)	Remark (QP/PK/AV)
1	7919.000	32.06	12.40	44.46	-23.74	68.20	Peak
2	* 10545.500	31.30	17.13	48.44	-19.76	68.20	Peak
3	11642.000	32.38	18.27	50.65	-23.35	74.00	Peak
4	12611.000	33.14	18.21	51.35	-22.65	74.00	Peak

Note:

- "*", means this data is the worst emission level.
- C.F (Correction Factor) = Antenna Factor (dB)+ Cable Loss (dB)– Preamplifier(dB).
- Measurement(dBUV/m) = Reading(dBUV) + C.F (Correction Factor).
- The emission levels of other frequencies are very lower than the limit and not show in test report.

EUT	AX1800 Wi-Fi 6 Range Extender	Date of Test	2021-05-07
Factor	BBHA 9120D (1GHz~18GHz)	Temp. / Humidity	25.4°C/52%
Polarity	Horizontal	Site / Test Engineer	AC1 / Jay
Test Mode	Transmit by 802.11ac-VHT20 at Channel 5220MHz	Test Voltage	AC 120V/60Hz

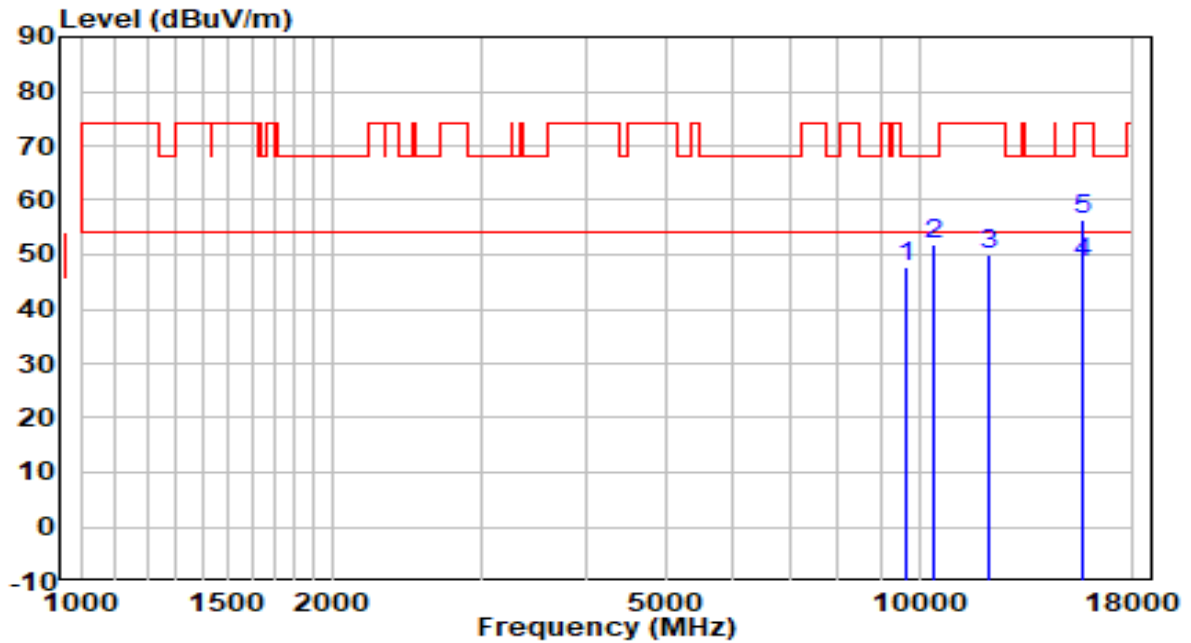

No	Frequency (MHz)	Reading (dBuV)	C.F (dB)	Measurement (dBuV/m)	Margin (dB)	Limit (dBuV/m)	Remark (QP/PK/AV)
1	9661.500	33.15	14.72	47.88	-20.32	68.20	Peak
2	10435.000	34.97	16.85	51.82	-16.38	68.20	Peak
3	12084.000	32.17	17.83	50.00	-24.00	74.00	Peak
4	* 15662.500	27.14	21.18	48.32	-5.68	54.00	Average
5	15662.500	35.42	21.18	56.60	-17.40	74.00	Peak

Note:

1. " *", means this data is the worst emission level.
2. C.F (Correction Factor) = Antenna Factor (dB)+ Cable Loss (dB)– Preamplifier(dB).
3. Measurement(dBuV/m) = Reading(dBuV) + C.F (Correction Factor).
- 4.The emission levels of other frequencies are very lower than the limit and not show in test report.

EUT	AX1800 Wi-Fi 6 Range Extender	Date of Test	2021-05-07
Factor	BBHA 9120D (1GHz~18GHz)	Temp. / Humidity	25.4°C/52%
Polarity	Vertical	Site / Test Engineer	AC1 / Jay
Test Mode	Transmit by 802.11ac-VHT20 at Channel 5220MHz	Test Voltage	AC 120V/60Hz

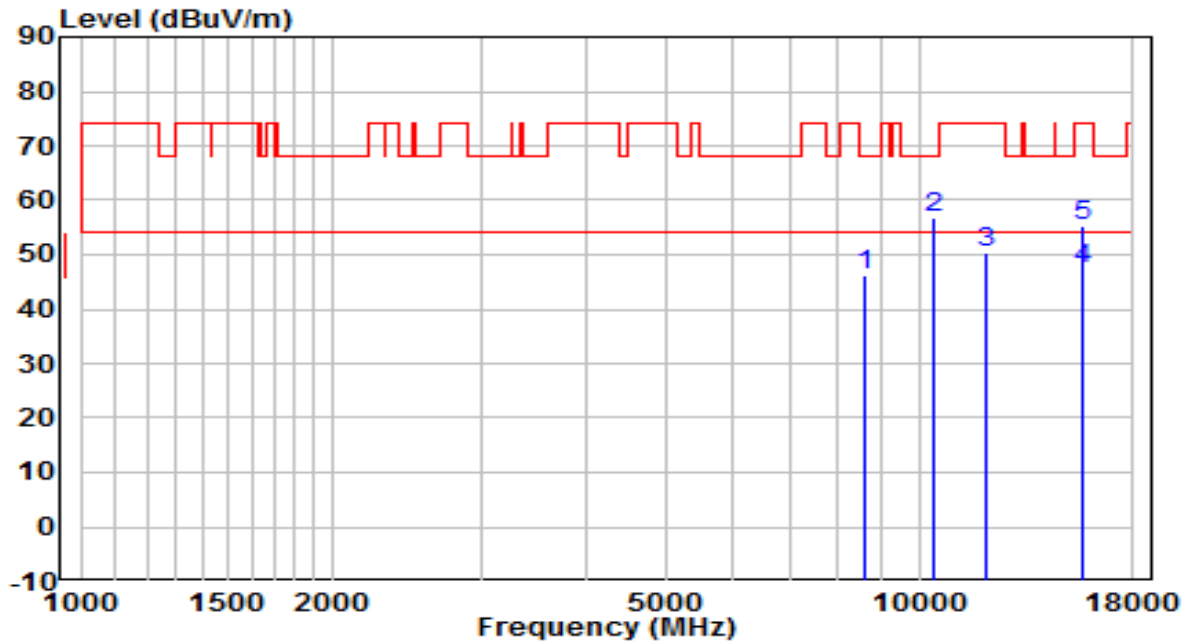

No	Frequency (MHz)	Reading (dBuV)	C.F (dB)	Measurement (dBuV/m)	Margin (dB)	Limit (dBuV/m)	Remark (QP/PK/AV)
1	8633.000	33.57	12.78	46.36	-21.84	68.20	Peak
2	10443.500	39.75	16.88	56.63	-11.57	68.20	Peak
3	12041.500	32.72	17.83	50.55	-23.45	74.00	Peak
4	* 15671.000	26.14	21.16	47.30	-6.70	54.00	Average
5	15671.000	34.24	21.16	55.40	-18.60	74.00	Peak

Note:

1. " *", means this data is the worst emission level.
2. C.F (Correction Factor) = Antenna Factor (dB)+ Cable Loss (dB)– Preamplifier(dB).
3. Measurement(dBuV/m) = Reading(dBuV) + C.F (Correction Factor).
- 4.The emission levels of other frequencies are very lower than the limit and not show in test report.

EUT	AX1800 Wi-Fi 6 Range Extender	Date of Test	2021-05-07
Factor	BBHA 9120D (1GHz~18GHz)	Temp. / Humidity	25.4°C/52%
Polarity	Horizontal	Site / Test Engineer	AC1 / Jay
Test Mode	Transmit by 802.11ac-VHT20 at Channel 5240MHz	Test Voltage	AC 120V/60Hz

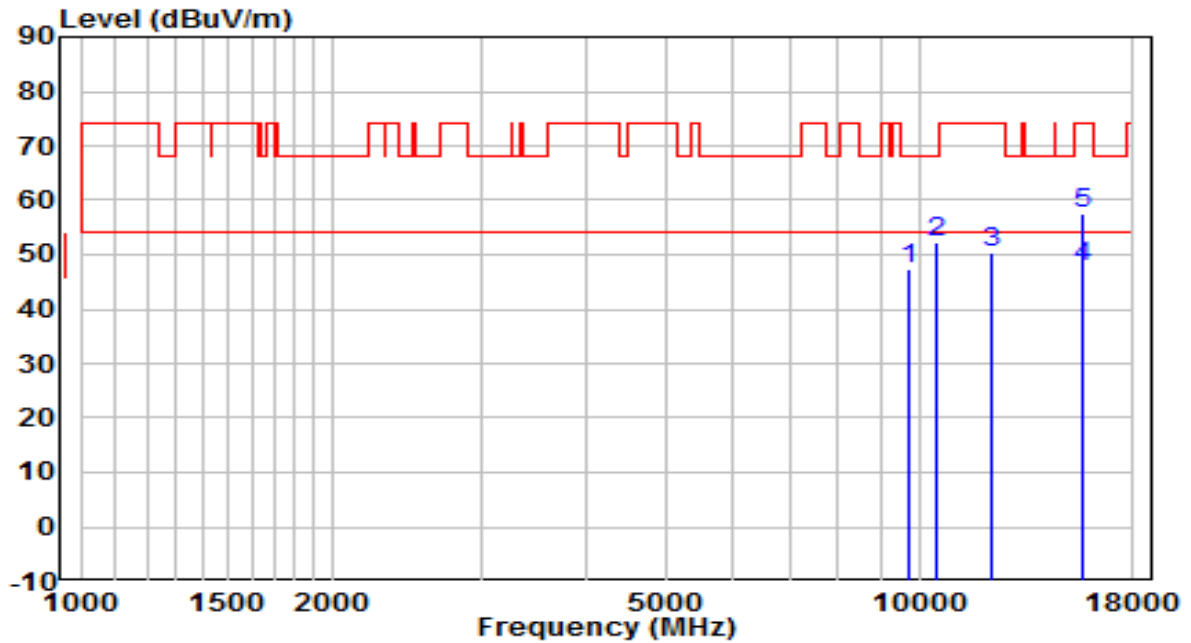

No	Frequency (MHz)	Reading (dBuV)	C.F (dB)	Measurement (dBuV/m)	Margin (dB)	Limit (dBuV/m)	Remark (QP/PK/AV)
1	9712.500	32.73	14.82	47.55	-20.65	68.20	Peak
2	10477.500	35.27	16.99	52.26	-15.94	68.20	Peak
3	12220.000	32.36	17.86	50.22	-23.78	74.00	Peak
4	* 15722.000	26.51	21.08	47.58	-6.42	54.00	Average
5	15722.000	36.42	21.08	57.50	-16.50	74.00	Peak

Note:

1. " *", means this data is the worst emission level.
2. C.F (Correction Factor) = Antenna Factor (dB)+ Cable Loss (dB)– Preamplifier(dB).
3. Measurement(dBuV/m) = Reading(dBuV) + C.F (Correction Factor).
- 4.The emission levels of other frequencies are very lower than the limit and not show in test report.

EUT	AX1800 Wi-Fi 6 Range Extender	Date of Test	2021-05-07
Factor	BBHA 9120D (1GHz~18GHz)	Temp. / Humidity	25.4°C/52%
Polarity	Vertical	Site / Test Engineer	AC1 / Jay
Test Mode	Transmit by 802.11ac-VHT20 at Channel 5240MHz	Test Voltage	AC 120V/60Hz

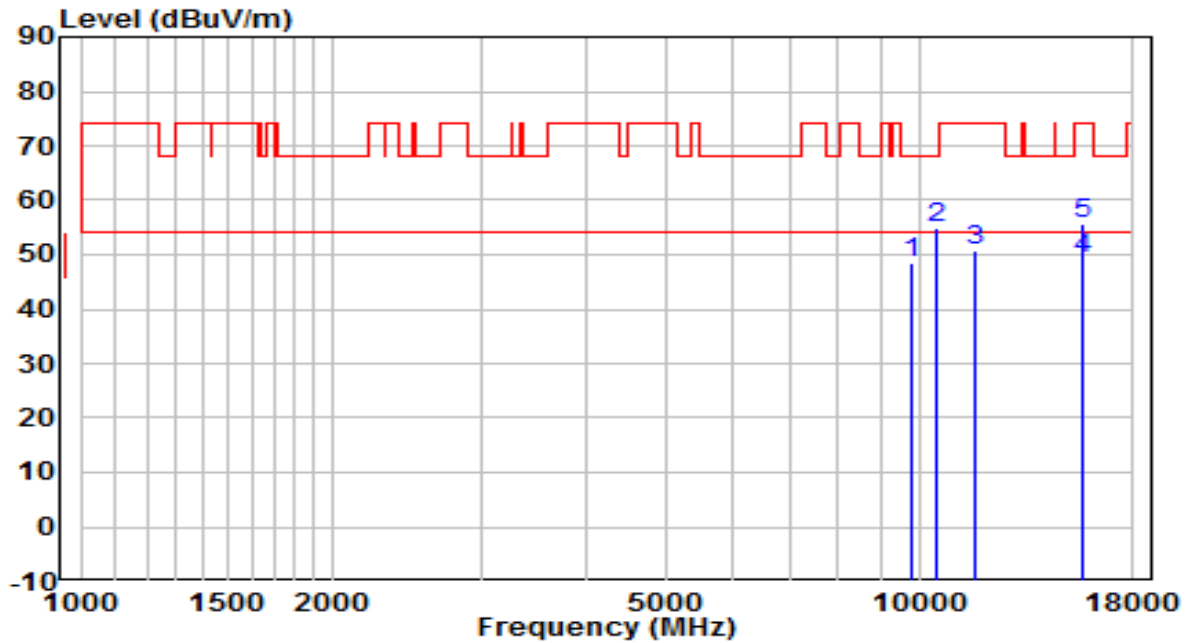

No	Frequency (MHz)	Reading (dBuV)	C.F (dB)	Measurement (dBuV/m)	Margin (dB)	Limit (dBuV/m)	Remark (QP/PK/AV)
1	9772.000	33.72	14.93	48.66	-19.54	68.20	Peak
2	10486.000	38.07	17.02	55.09	-13.11	68.20	Peak
3	11642.000	32.64	18.27	50.91	-23.09	74.00	Peak
4	* 15722.000	28.21	21.08	49.28	-4.72	54.00	Average
5	15722.000	34.55	21.08	55.63	-18.37	74.00	Peak

Note:

1. " *", means this data is the worst emission level.
2. C.F (Correction Factor) = Antenna Factor (dB)+ Cable Loss (dB)– Preamplifier(dB).
3. Measurement(dBuV/m) = Reading(dBuV) + C.F (Correction Factor).
- 4.The emission levels of other frequencies are very lower than the limit and not show in test report.

EUT	AX1800 Wi-Fi 6 Range Extender	Date of Test	2021-05-07
Factor	BBHA 9120D (1GHz~18GHz)	Temp. / Humidity	25.4°C/52%
Polarity	Horizontal	Site / Test Engineer	AC1 / Jay
Test Mode	Transmit by 802.11ac-VHT20 at Channel 5260MHz	Test Voltage	AC 120V/60Hz

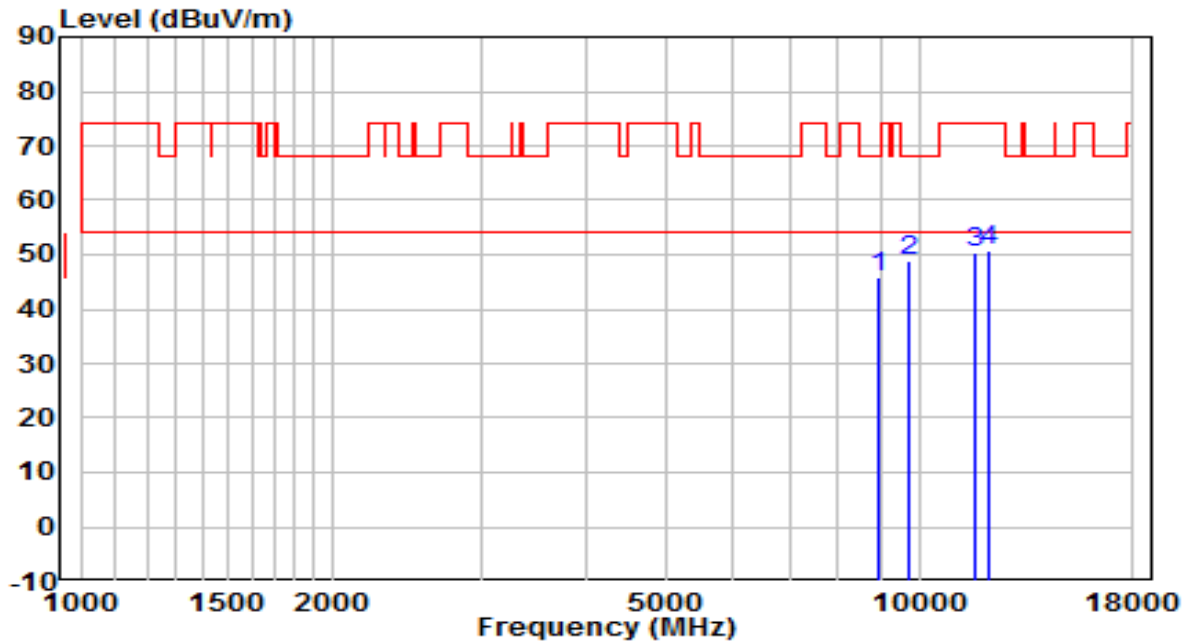

No	Frequency (MHz)	Reading (dBuV)	C.F (dB)	Measurement (dBuV/m)	Margin (dB)	Limit (dBuV/m)	Remark (QP/PK/AV)
1	8922.000	32.46	13.49	45.95	-22.25	68.20	Peak
2	* 9738.000	33.92	14.87	48.78	-19.42	68.20	Peak
3	11642.000	32.23	18.27	50.50	-23.50	74.00	Peak
4	12143.500	33.00	17.84	50.84	-23.16	74.00	Peak

Note:

- "*", means this data is the worst emission level.
- C.F (Correction Factor) = Antenna Factor (dB)+ Cable Loss (dB)– Preamplifier(dB).
- Measurement(dBuV/m) = Reading(dBuV) + C.F (Correction Factor).
- The emission levels of other frequencies are very lower than the limit and not show in test report.

EUT	AX1800 Wi-Fi 6 Range Extender	Date of Test	2021-05-07
Factor	BBHA 9120D (1GHz~18GHz)	Temp. / Humidity	25.4°C/52%
Polarity	Vertical	Site / Test Engineer	AC1 / Jay
Test Mode	Transmit by 802.11ac-VHT20 at Channel 5260MHz	Test Voltage	AC 120V/60Hz

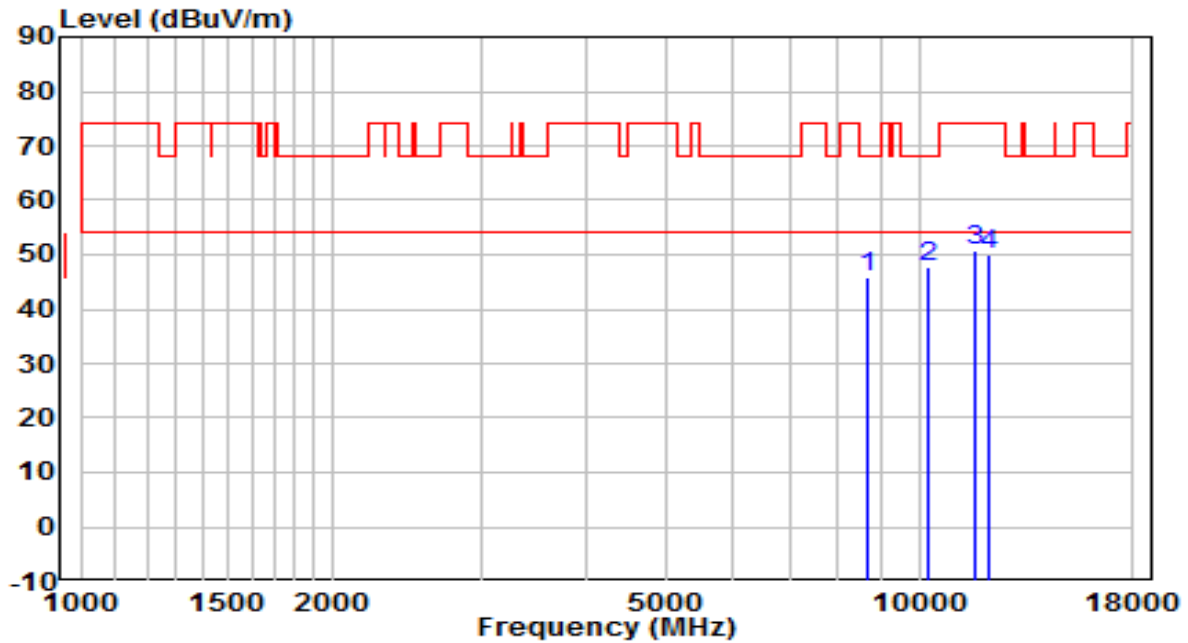

No	Frequency (MHz)	Reading (dBuV)	C.F (dB)	Measurement (dBuV/m)	Margin (dB)	Limit (dBuV/m)	Remark (QP/PK/AV)
1	8684.000	32.86	12.91	45.76	-22.44	68.20	Peak
2	* 10248.000	31.40	16.21	47.61	-20.59	68.20	Peak
3	11642.000	32.41	18.27	50.68	-23.32	74.00	Peak
4	12118.000	32.31	17.84	50.15	-23.85	74.00	Peak

Note:

- "*", means this data is the worst emission level.
- C.F (Correction Factor) = Antenna Factor (dB)+ Cable Loss (dB)– Preamplifier(dB).
- Measurement(dBuV/m) = Reading(dBuV) + C.F (Correction Factor).
- The emission levels of other frequencies are very lower than the limit and not show in test report.

EUT	AX1800 Wi-Fi 6 Range Extender	Date of Test	2021-05-07
Factor	BBHA 9120D (1GHz~18GHz)	Temp. / Humidity	25.4°C/52%
Polarity	Horizontal	Site / Test Engineer	AC1 / Jay
Test Mode	Transmit by 802.11ac-VHT20 at Channel 5300MHz	Test Voltage	AC 120V/60Hz

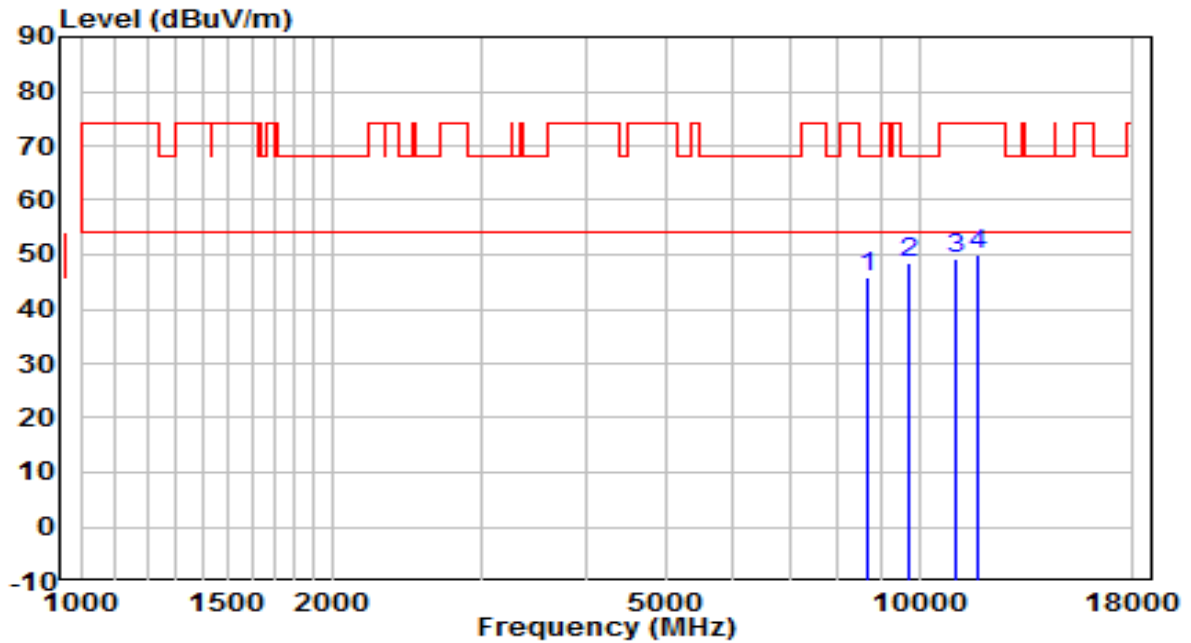

No	Frequency (MHz)	Reading (dBUV)	C.F (dB)	Measurement (dBUV/m)	Margin (dB)	Limit (dBUV/m)	Remark (QP/PK/AV)
1	8658.500	33.14	12.84	45.98	-22.22	68.20	Peak
2	* 9695.500	33.53	14.79	48.32	-19.88	68.20	Peak
3	11055.500	31.53	17.85	49.39	-24.61	74.00	Peak
4	11710.000	31.73	18.19	49.92	-24.08	74.00	Peak

Note:

- "*", means this data is the worst emission level.
- C.F (Correction Factor) = Antenna Factor (dB)+ Cable Loss (dB)– Preamplifier(dB).
- Measurement(dBUV/m) = Reading(dBUV) + C.F (Correction Factor).
- The emission levels of other frequencies are very lower than the limit and not show in test report.

EUT	AX1800 Wi-Fi 6 Range Extender	Date of Test	2021-05-07
Factor	BBHA 9120D (1GHz~18GHz)	Temp. / Humidity	25.4°C/52%
Polarity	Vertical	Site / Test Engineer	AC1 / Jay
Test Mode	Transmit by 802.11ac-VHT20 at Channel 5300MHz	Test Voltage	AC 120V/60Hz

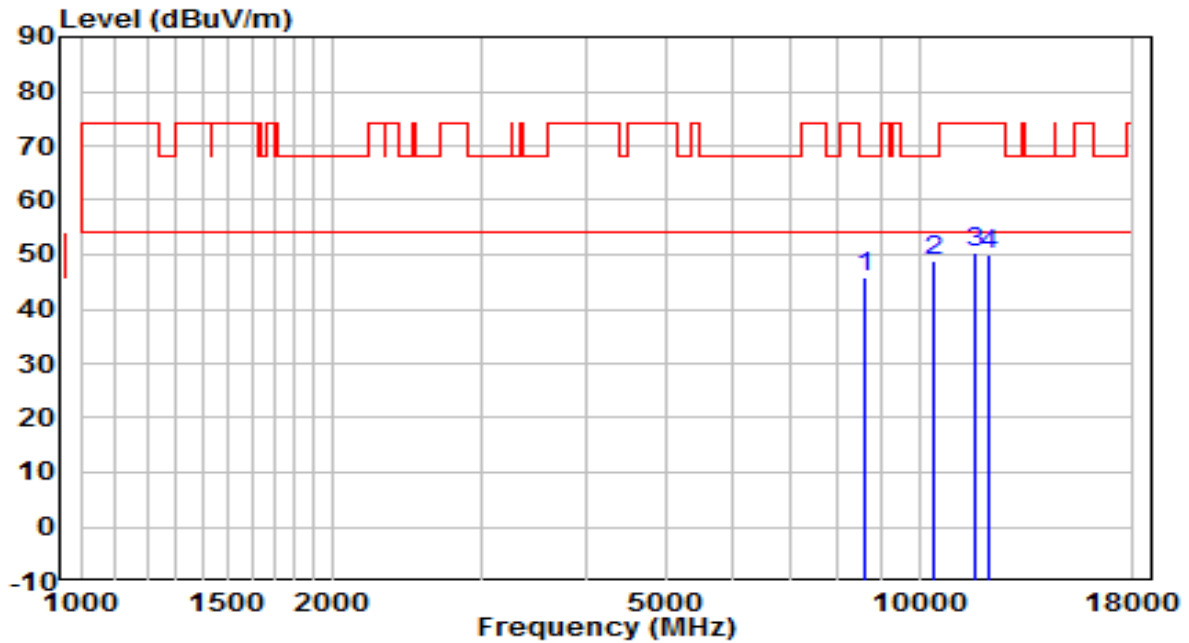

No	Frequency (MHz)	Reading (dBUV)	C.F (dB)	Measurement (dBUV/m)	Margin (dB)	Limit (dBUV/m)	Remark (QP/PK/AV)
1	8641.500	33.01	12.80	45.81	-22.39	68.20	Peak
2	* 10384.000	32.08	16.67	48.75	-19.45	68.20	Peak
3	11642.000	32.09	18.27	50.36	-23.64	74.00	Peak
4	12118.000	31.99	17.84	49.83	-24.17	74.00	Peak

Note:

- " *", means this data is the worst emission level.
- C.F (Correction Factor) = Antenna Factor (dB)+ Cable Loss (dB)– Preamplifier(dB).
- Measurement(dBUV/m) = Reading(dBUV) + C.F (Correction Factor).
- The emission levels of other frequencies are very lower than the limit and not show in test report.

EUT	AX1800 Wi-Fi 6 Range Extender	Date of Test	2021-05-07
Factor	BBHA 9120D (1GHz~18GHz)	Temp. / Humidity	25.4°C/52%
Polarity	Horizontal	Site / Test Engineer	AC1 / Jay
Test Mode	Transmit by 802.11ac-VHT20 at Channel 5320MHz	Test Voltage	AC 120V/60Hz

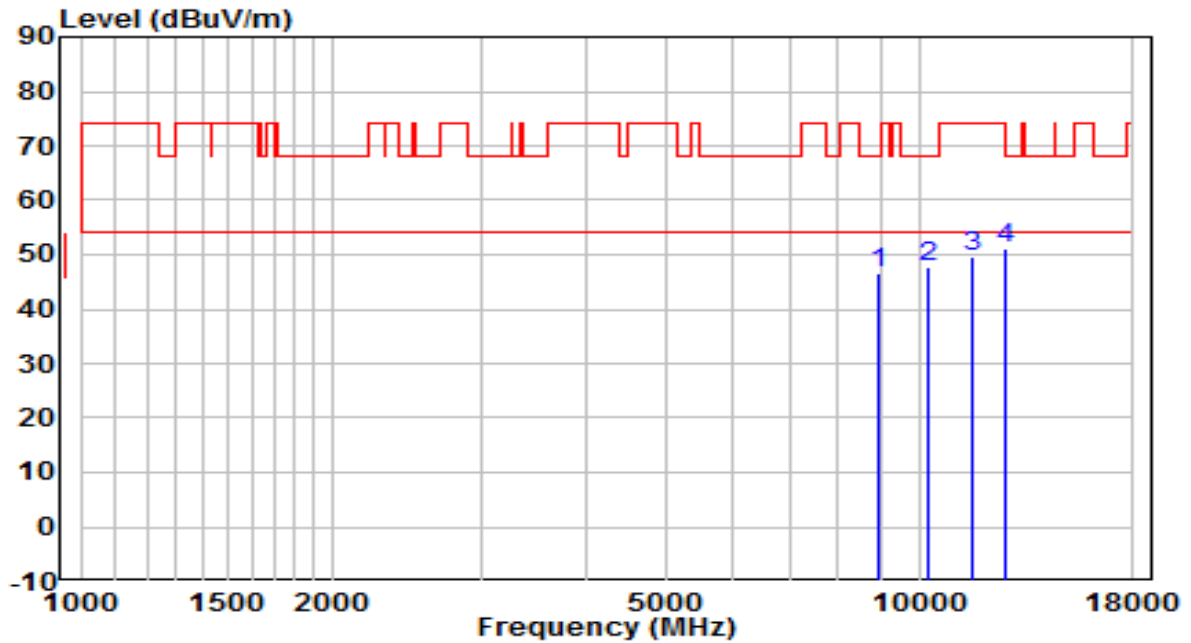

No	Frequency (MHz)	Reading (dBUV)	C.F (dB)	Measurement (dBUV/m)	Margin (dB)	Limit (dBUV/m)	Remark (QP/PK/AV)
1	8947.500	32.95	13.55	46.51	-21.69	68.20	Peak
2	* 10256.500	31.68	16.24	47.92	-20.28	68.20	Peak
3	11582.500	31.38	18.35	49.73	-24.27	74.00	Peak
4	12636.500	32.89	18.28	51.17	-22.83	74.00	Peak

Note:

- "*", means this data is the worst emission level.
- C.F (Correction Factor) = Antenna Factor (dB)+ Cable Loss (dB)– Preamplifier(dB).
- Measurement(dBUV/m) = Reading(dBUV) + C.F (Correction Factor).
- The emission levels of other frequencies are very lower than the limit and not show in test report.

EUT	AX1800 Wi-Fi 6 Range Extender	Date of Test	2021-05-07
Factor	BBHA 9120D (1GHz~18GHz)	Temp. / Humidity	25.4°C/52%
Polarity	Vertical	Site / Test Engineer	AC1 / Jay
Test Mode	Transmit by 802.11ac-VHT20 at Channel 5320MHz	Test Voltage	AC 120V/60Hz

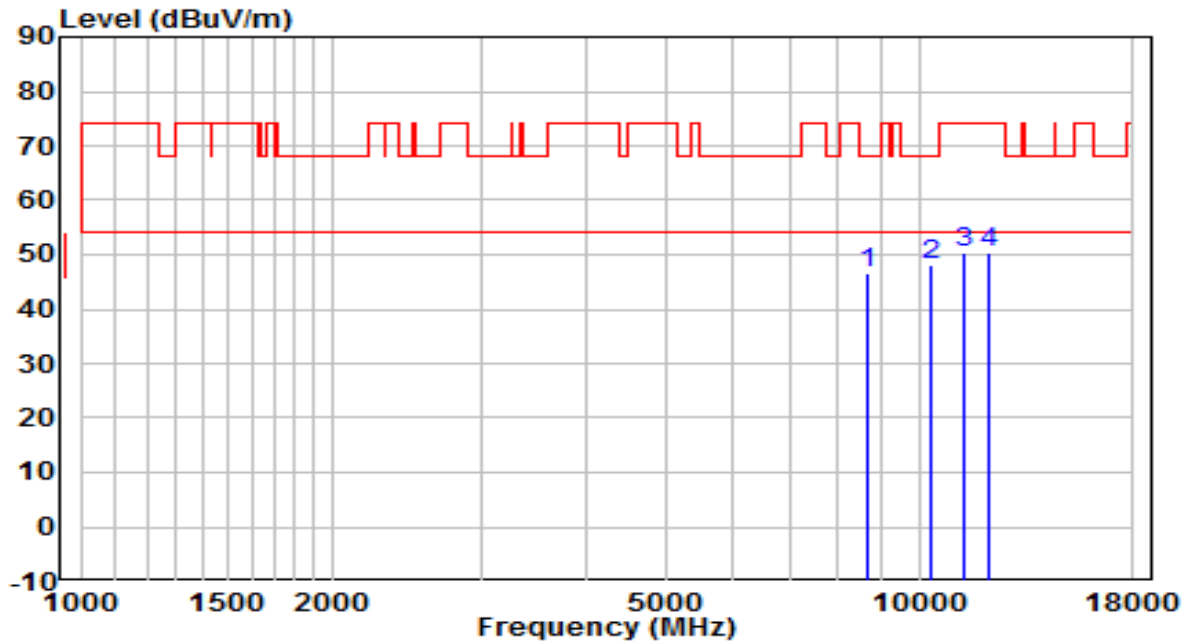

No	Frequency (MHz)	Reading (dBuV)	C.F (dB)	Measurement (dBuV/m)	Margin (dB)	Limit (dBuV/m)	Remark (QP/PK/AV)
1	8709.500	33.74	12.97	46.71	-21.49	68.20	Peak
2	* 10299.000	31.65	16.38	48.03	-20.17	68.20	Peak
3	11302.000	32.15	18.18	50.33	-23.67	74.00	Peak
4	12109.500	32.37	17.84	50.21	-23.79	74.00	Peak

Note:

1. " *", means this data is the worst emission level.
2. C.F (Correction Factor) = Antenna Factor (dB)+ Cable Loss (dB)– Preamplifier(dB).
3. Measurement(dBuV/m) = Reading(dBuV) + C.F (Correction Factor).
- 4.The emission levels of other frequencies are very lower than the limit and not show in test report.

EUT	AX1800 Wi-Fi 6 Range Extender	Date of Test	2021-05-07
Factor	BBHA 9120D (1GHz~18GHz)	Temp. / Humidity	25.4°C/52%
Polarity	Horizontal	Site / Test Engineer	AC1 / Jay
Test Mode	Transmit by 802.11ac-VHT20 at Channel 5500MHz	Test Voltage	AC 120V/60Hz

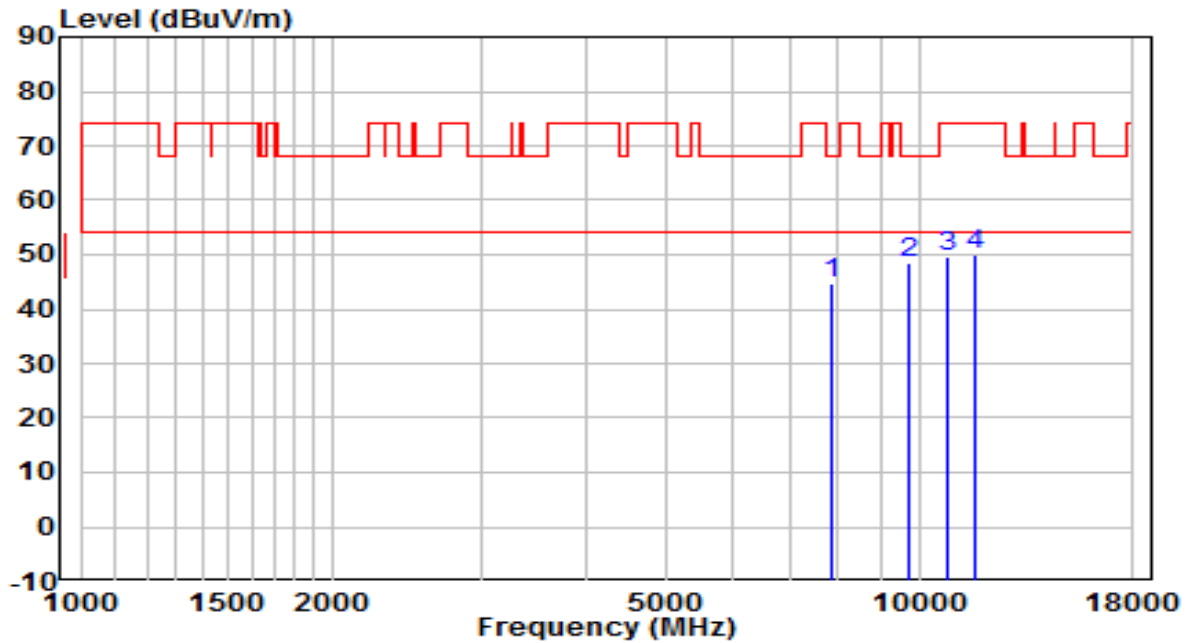

No	Frequency (MHz)	Reading (dBUV)	C.F (dB)	Measurement (dBUV/m)	Margin (dB)	Limit (dBUV/m)	Remark (QP/PK/AV)
1	7893.500	32.54	12.36	44.90	-23.30	68.20	Peak
2	* 9738.000	33.58	14.87	48.45	-19.75	68.20	Peak
3	10775.000	32.06	17.46	49.52	-24.48	74.00	Peak
4	11642.000	31.74	18.27	50.01	-23.99	74.00	Peak

Note:

- "*", means this data is the worst emission level.
- C.F (Correction Factor) = Antenna Factor (dB)+ Cable Loss (dB)– Preamplifier(dB).
- Measurement(dBUV/m) = Reading(dBUV) + C.F (Correction Factor).
- The emission levels of other frequencies are very lower than the limit and not show in test report.

EUT	AX1800 Wi-Fi 6 Range Extender	Date of Test	2021-05-07
Factor	BBHA 9120D (1GHz~18GHz)	Temp. / Humidity	25.4°C/52%
Polarity	Vertical	Site / Test Engineer	AC1 / Jay
Test Mode	Transmit by 802.11ac-VHT20 at Channel 5500MHz	Test Voltage	AC 120V/60Hz

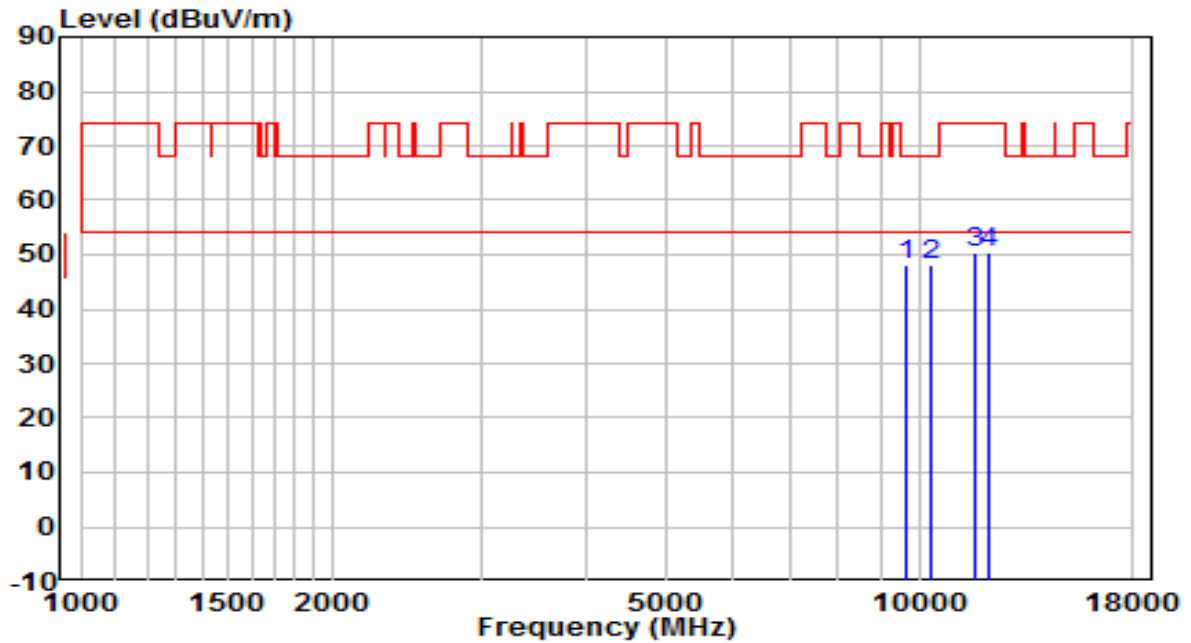

No	Frequency (MHz)	Reading (dBuV)	C.F (dB)	Measurement (dBuV/m)	Margin (dB)	Limit (dBuV/m)	Remark (QP/PK/AV)
1	9627.500	33.33	14.66	47.99	-20.21	68.20	Peak
2	* 10307.500	31.66	16.41	48.07	-20.13	68.20	Peak
3	11701.500	32.16	18.20	50.36	-23.64	74.00	Peak
4	12143.500	32.41	17.84	50.25	-23.75	74.00	Peak

Note:

1. " *", means this data is the worst emission level.
2. C.F (Correction Factor) = Antenna Factor (dB)+ Cable Loss (dB)– Preamplifier(dB).
3. Measurement(dBuV/m) = Reading(dBuV) + C.F (Correction Factor).
- 4.The emission levels of other frequencies are very lower than the limit and not show in test report.

EUT	AX1800 Wi-Fi 6 Range Extender	Date of Test	2021-05-07
Factor	BBHA 9120D (1GHz~18GHz)	Temp. / Humidity	25.4°C/52%
Polarity	Horizontal	Site / Test Engineer	AC1 / Jay
Test Mode	Transmit by 802.11ac-VHT20 at Channel 5580MHz	Test Voltage	AC 120V/60Hz

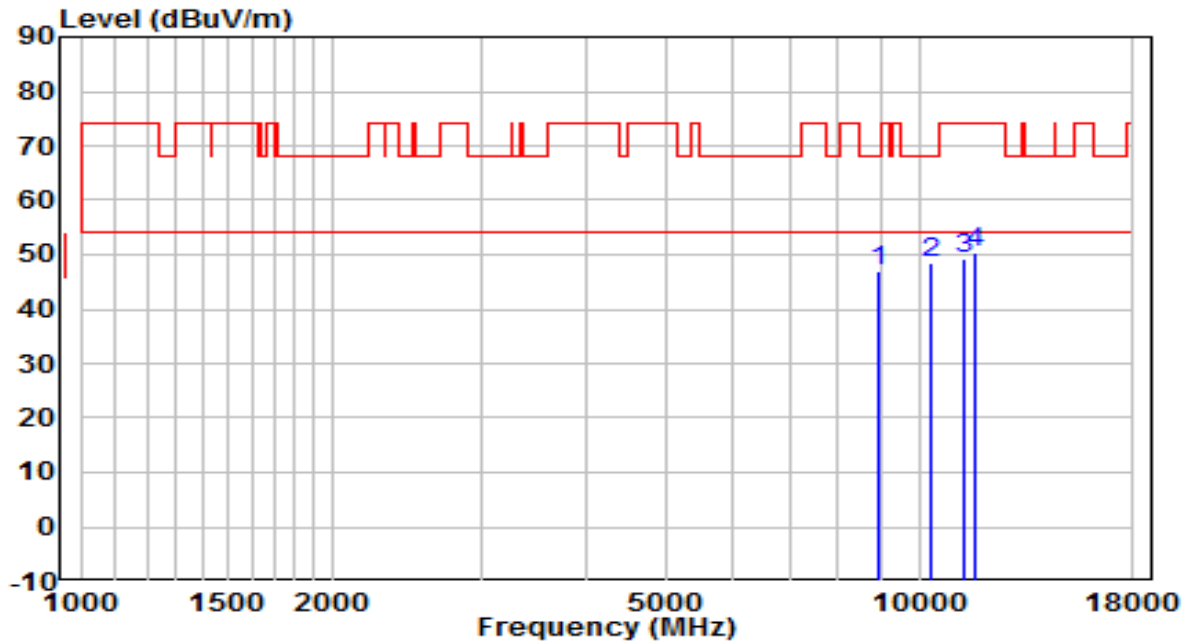

No	Frequency (MHz)	Reading (dBuV)	C.F (dB)	Measurement (dBuV/m)	Margin (dB)	Limit (dBuV/m)	Remark (QP/PK/AV)
1	8964.500	33.26	13.59	46.85	-21.35	68.20	Peak
2	* 10367.000	31.83	16.62	48.44	-19.76	68.20	Peak
3	11276.500	31.17	18.15	49.32	-24.68	74.00	Peak
4	11650.500	32.13	18.26	50.39	-23.61	74.00	Peak

Note:

- "*", means this data is the worst emission level.
- C.F (Correction Factor) = Antenna Factor (dB)+ Cable Loss (dB)– Preamplifier(dB).
- Measurement(dBuV/m) = Reading(dBuV) + C.F (Correction Factor).
- The emission levels of other frequencies are very lower than the limit and not show in test report.

EUT	AX1800 Wi-Fi 6 Range Extender	Date of Test	2021-05-07
Factor	BBHA 9120D (1GHz~18GHz)	Temp. / Humidity	25.4°C/52%
Polarity	Vertical	Site / Test Engineer	AC1 / Jay
Test Mode	Transmit by 802.11ac-VHT20 at Channel 5580MHz	Test Voltage	AC 120V/60Hz

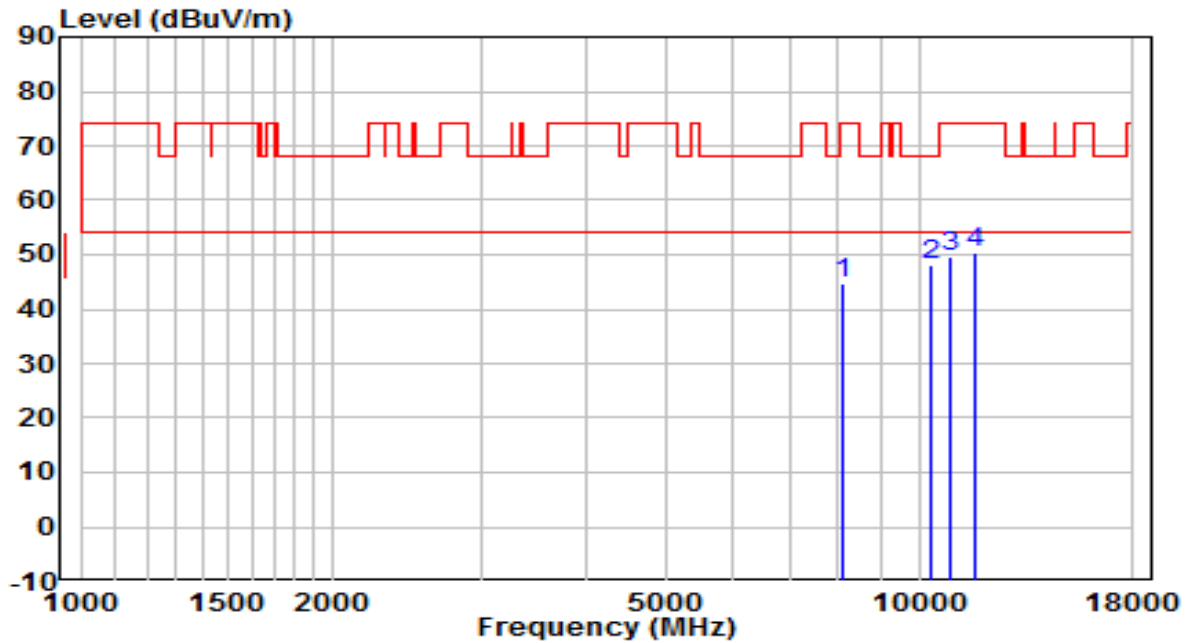

No	Frequency (MHz)	Reading (dBuV)	C.F (dB)	Measurement (dBuV/m)	Margin (dB)	Limit (dBuV/m)	Remark (QP/PK/AV)
1	8123.000	32.15	12.51	44.66	-29.34	74.00	Peak
2	* 10307.500	31.56	16.41	47.97	-20.23	68.20	Peak
3	10911.000	31.82	17.65	49.48	-24.52	74.00	Peak
4	11650.500	32.17	18.26	50.43	-23.57	74.00	Peak

Note:

- "*", means this data is the worst emission level.
- C.F (Correction Factor) = Antenna Factor (dB)+ Cable Loss (dB)– Preamplifier(dB).
- Measurement(dBuV/m) = Reading(dBuV) + C.F (Correction Factor).
- The emission levels of other frequencies are very lower than the limit and not show in test report.

EUT	AX1800 Wi-Fi 6 Range Extender	Date of Test	2021-05-07
Factor	BBHA 9120D (1GHz~18GHz)	Temp. / Humidity	25.4°C/52%
Polarity	Horizontal	Site / Test Engineer	AC1 / Jay
Test Mode	Transmit by 802.11ac-VHT20 at Channel 5700MHz	Test Voltage	AC 120V/60Hz

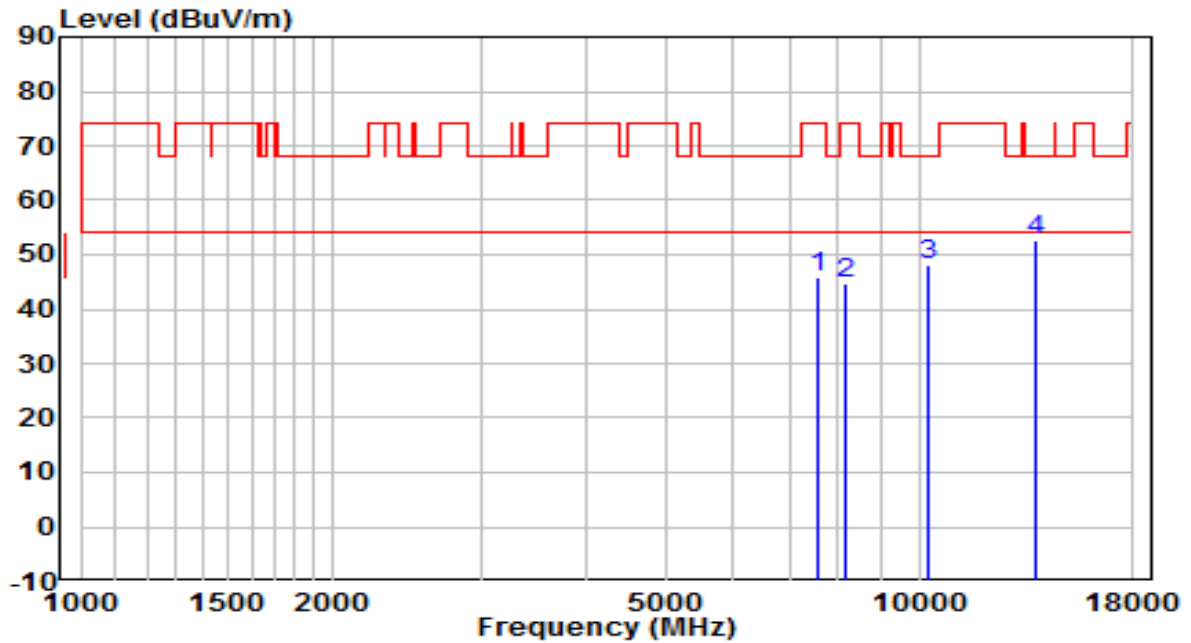

No	Frequency (MHz)	Reading (dBUV)	C.F (dB)	Measurement (dBUV/m)	Margin (dB)	Limit (dBUV/m)	Remark (QP/PK/AV)
1	7579.000	33.99	11.84	45.83	-28.17	74.00	Peak
2	8191.000	32.31	12.50	44.81	-29.19	74.00	Peak
3	10239.500	31.86	16.18	48.04	-20.16	68.20	Peak
4	* 13818.000	31.33	21.17	52.50	-15.70	68.20	Peak

Note:

1. " *", means this data is the worst emission level.
2. C.F (Correction Factor) = Antenna Factor (dB)+ Cable Loss (dB)– Preamplifier(dB).
3. Measurement(dBUV/m) = Reading(dBUV) + C.F (Correction Factor).
- 4.The emission levels of other frequencies are very lower than the limit and not show in test report.

EUT	AX1800 Wi-Fi 6 Range Extender	Date of Test	2021-05-07
Factor	BBHA 9120D (1GHz~18GHz)	Temp. / Humidity	25.4°C/52%
Polarity	Vertical	Site / Test Engineer	AC1 / Jay
Test Mode	Transmit by 802.11ac-VHT20 at Channel 5700MHz	Test Voltage	AC 120V/60Hz

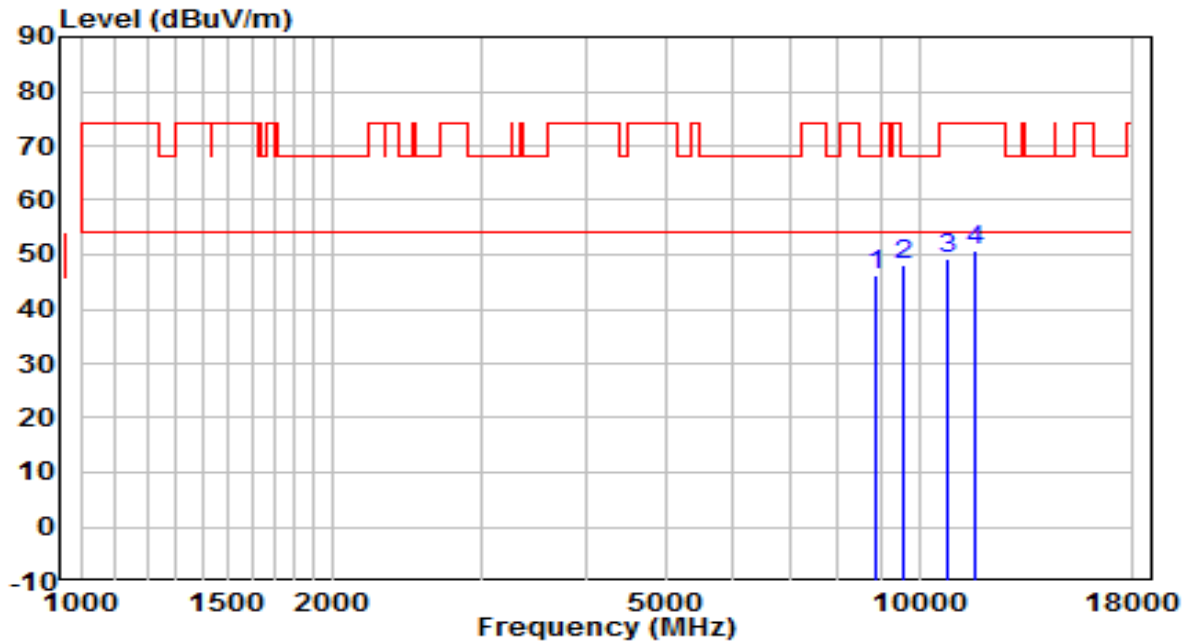

No	Frequency (MHz)	Reading (dBuV)	C.F (dB)	Measurement (dBuV/m)	Margin (dB)	Limit (dBuV/m)	Remark (QP/PK/AV)
1	8879.500	32.74	13.38	46.12	-22.08	68.20	Peak
2	* 9576.500	33.54	14.56	48.10	-20.10	68.20	Peak
3	10826.000	31.55	17.53	49.08	-24.92	74.00	Peak
4	11659.000	32.45	18.25	50.70	-23.30	74.00	Peak

Note:

- "*", means this data is the worst emission level.
- C.F (Correction Factor) = Antenna Factor (dB)+ Cable Loss (dB)– Preamplifier(dB).
- Measurement(dBuV/m) = Reading(dBuV) + C.F (Correction Factor).
- The emission levels of other frequencies are very lower than the limit and not show in test report.

EUT	AX1800 Wi-Fi 6 Range Extender	Date of Test	2021-05-07
Factor	BBHA 9120D (1GHz~18GHz)	Temp. / Humidity	25.4°C/52%
Polarity	Horizontal	Site / Test Engineer	AC1 / Jay
Test Mode	Transmit by 802.11ac-VHT20 at Channel 5745MHz	Test Voltage	AC 120V/60Hz

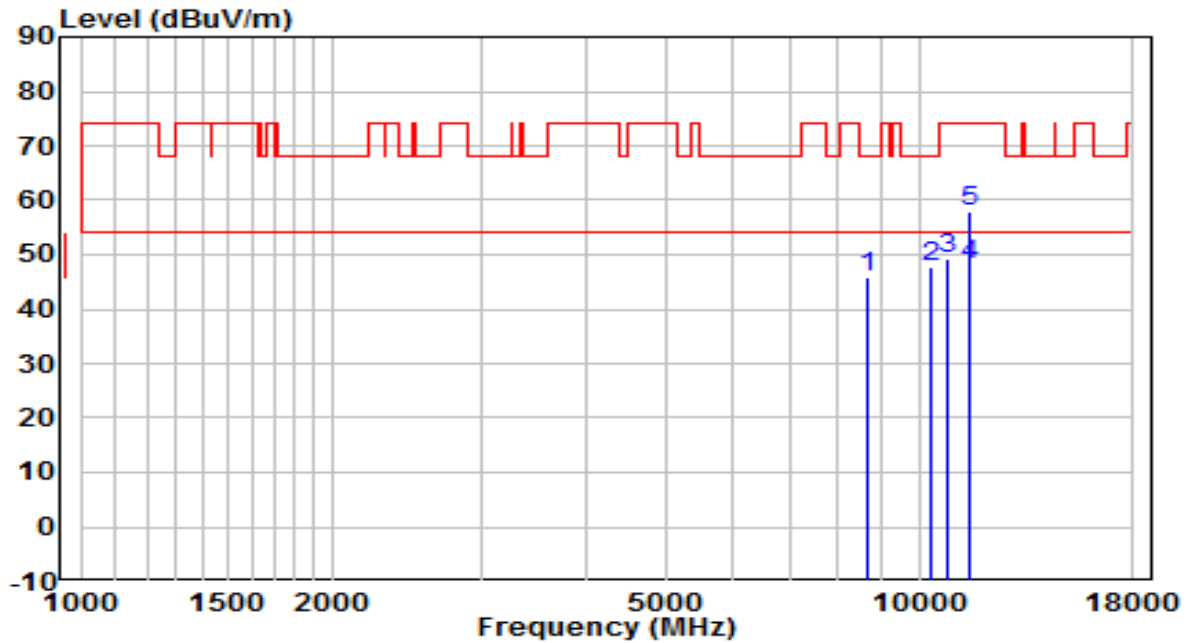

No	Frequency (MHz)	Reading (dBuV)	C.F (dB)	Measurement (dBuV/m)	Margin (dB)	Limit (dBuV/m)	Remark (QP/PK/AV)
1	8675.500	32.89	12.88	45.77	-22.43	68.20	Peak
2	10307.500	31.46	16.41	47.87	-20.33	68.20	Peak
3	10783.500	31.86	17.47	49.33	-24.67	74.00	Peak
4	* 11489.700	29.68	18.44	48.12	-5.88	54.00	Average
5	11497.500	39.63	18.45	58.08	-15.92	74.00	Peak

Note:

1. " *", means this data is the worst emission level.
2. C.F (Correction Factor) = Antenna Factor (dB)+ Cable Loss (dB)– Preamplifier(dB).
3. Measurement(dBuV/m) = Reading(dBuV) + C.F (Correction Factor).
- 4.The emission levels of other frequencies are very lower than the limit and not show in test report.

EUT	AX1800 Wi-Fi 6 Range Extender	Date of Test	2021-05-07
Factor	BBHA 9120D (1GHz~18GHz)	Temp. / Humidity	25.4°C/52%
Polarity	Vertical	Site / Test Engineer	AC1 / Jay
Test Mode	Transmit by 802.11ac-VHT20 at Channel 5745MHz	Test Voltage	AC 120V/60Hz

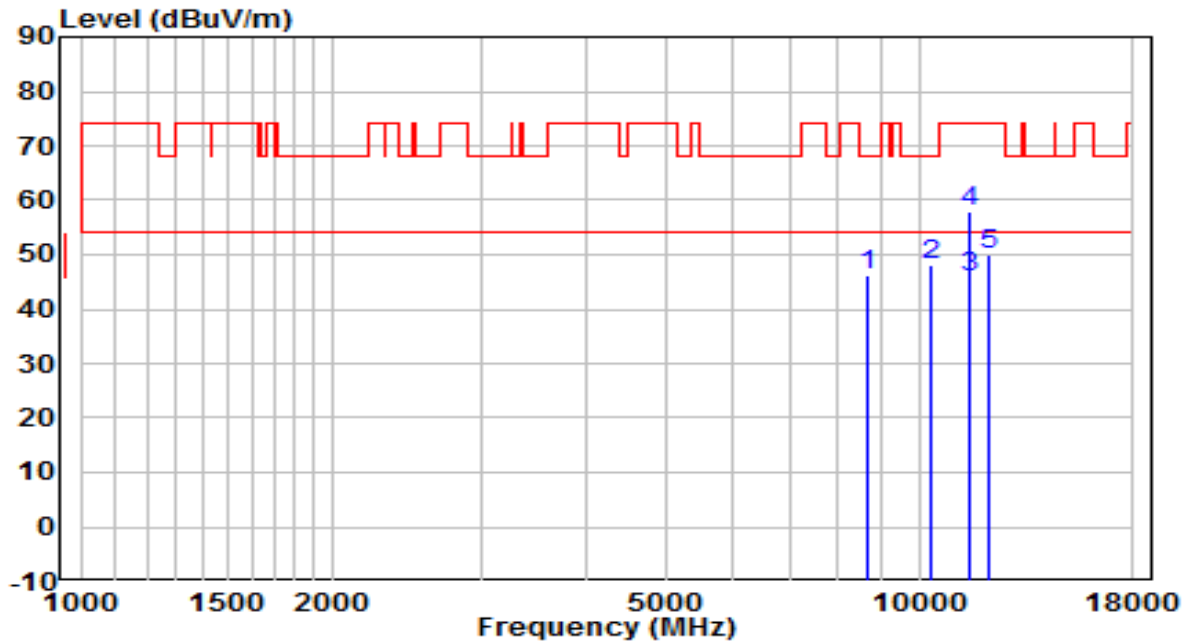

No	Frequency (MHz)	Reading (dBuV)	C.F (dB)	Measurement (dBuV/m)	Margin (dB)	Limit (dBuV/m)	Remark (QP/PK/AV)
1	8650.000	33.49	12.82	46.31	-21.89	68.20	Peak
2	10316.000	31.74	16.44	48.18	-20.02	68.20	Peak
3	* 11489.000	27.58	18.44	46.02	-7.98	54.00	Average
4	11489.000	39.34	18.44	57.77	-16.23	74.00	Peak
5	12109.500	32.00	17.84	49.84	-24.16	74.00	Peak

Note:

1. " *", means this data is the worst emission level.
2. C.F (Correction Factor) = Antenna Factor (dB)+ Cable Loss (dB)– Preamplifier(dB).
3. Measurement(dBuV/m) = Reading(dBuV) + C.F (Correction Factor).
- 4.The emission levels of other frequencies are very lower than the limit and not show in test report.

EUT	AX1800 Wi-Fi 6 Range Extender	Date of Test	2021-05-07
Factor	BBHA 9120D (1GHz~18GHz)	Temp. / Humidity	25.4°C/52%
Polarity	Horizontal	Site / Test Engineer	AC1 / Jay
Test Mode	Transmit by 802.11ac-VHT20 at Channel 5785MHz	Test Voltage	AC 120V/60Hz

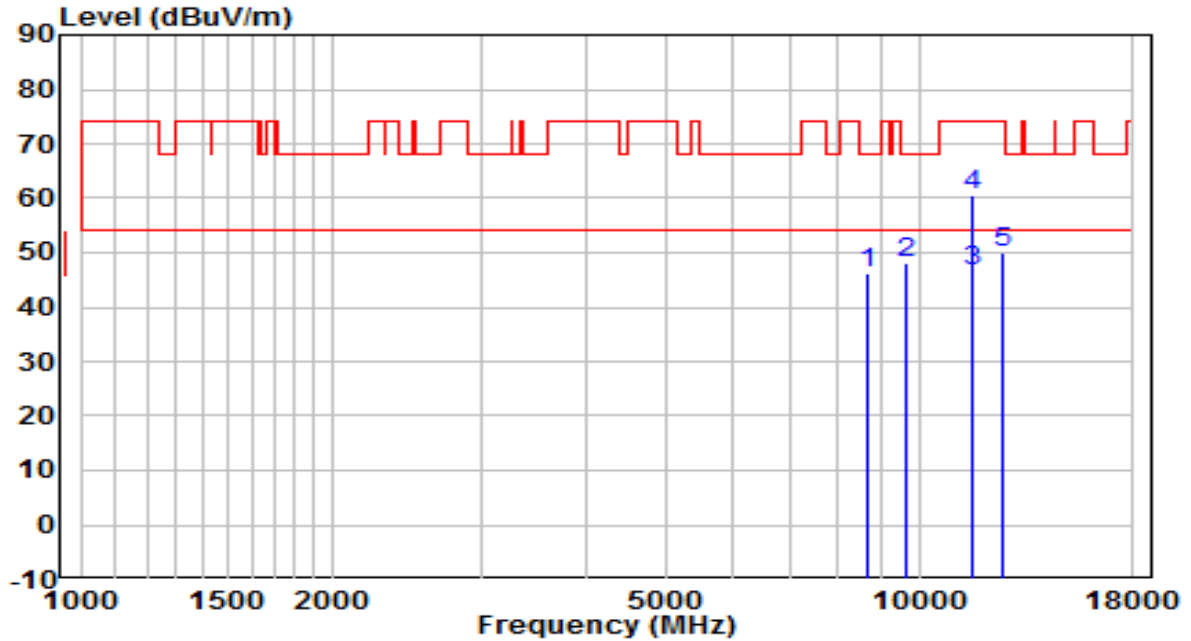

No	Frequency (MHz)	Reading (dBuV)	C.F (dB)	Measurement (dBuV/m)	Margin (dB)	Limit (dBuV/m)	Remark (QP/PK/AV)
1	8675.500	33.29	12.88	46.18	-22.02	68.20	Peak
2	9636.000	33.40	14.68	48.07	-20.13	68.20	Peak
3	* 11574.000	28.29	18.36	46.64	-7.36	54.00	Average
4	11574.000	42.32	18.36	60.67	-13.33	74.00	Peak
5	12568.500	32.06	18.09	50.15	-23.85	74.00	Peak

Note:

- "*" means this data is the worst emission level.
- C.F (Correction Factor) = Antenna Factor (dB)+ Cable Loss (dB)– Preamplifier(dB).
- Measurement(dBuV/m) = Reading(dBuV) + C.F (Correction Factor).
- The emission levels of other frequencies are very lower than the limit and not show in test report.

EUT	AX1800 Wi-Fi 6 Range Extender	Date of Test	2021-05-07
Factor	BBHA 9120D (1GHz~18GHz)	Temp. / Humidity	25.4°C/52%
Polarity	Vertical	Site / Test Engineer	AC1 / Jay
Test Mode	Transmit by 802.11ac-VHT20 at Channel 5785MHz	Test Voltage	AC 120V/60Hz

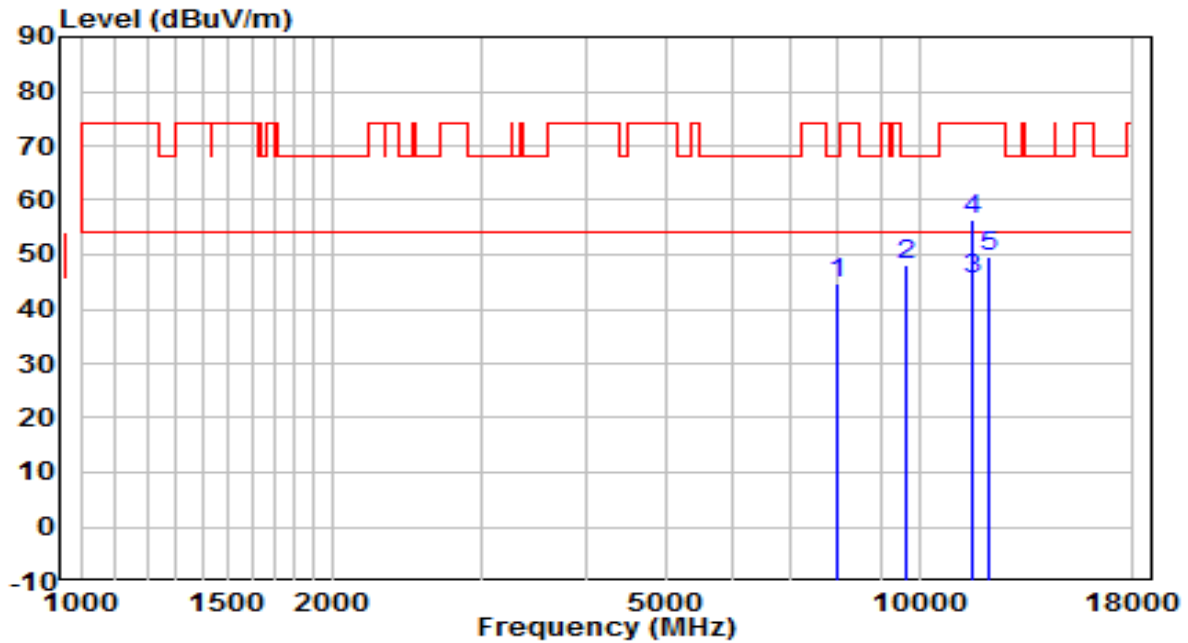

No	Frequency (MHz)	Reading (dBuV)	C.F (dB)	Measurement (dBuV/m)	Margin (dB)	Limit (dBuV/m)	Remark (QP/PK/AV)
1	7987.000	32.13	12.51	44.63	-23.57	68.20	Peak
2	9644.500	33.23	14.69	47.93	-20.27	68.20	Peak
3	* 11574.000	27.22	18.36	45.58	-8.42	54.00	Average
4	11574.000	38.12	18.36	56.48	-17.52	74.00	Peak
5	12152.000	31.95	17.85	49.80	-24.20	74.00	Peak

Note:

- "*" means this data is the worst emission level.
- C.F (Correction Factor) = Antenna Factor (dB)+ Cable Loss (dB)– Preamplifier(dB).
- Measurement(dBuV/m) = Reading(dBuV) + C.F (Correction Factor).
- The emission levels of other frequencies are very lower than the limit and not show in test report.

EUT	AX1800 Wi-Fi 6 Range Extender	Date of Test	2021-05-07
Factor	BBHA 9120D (1GHz~18GHz)	Temp. / Humidity	25.4°C/52%
Polarity	Horizontal	Site / Test Engineer	AC1 / Jay
Test Mode	Transmit by 802.11ac-VHT20 at Channel 5825MHz	Test Voltage	AC 120V/60Hz

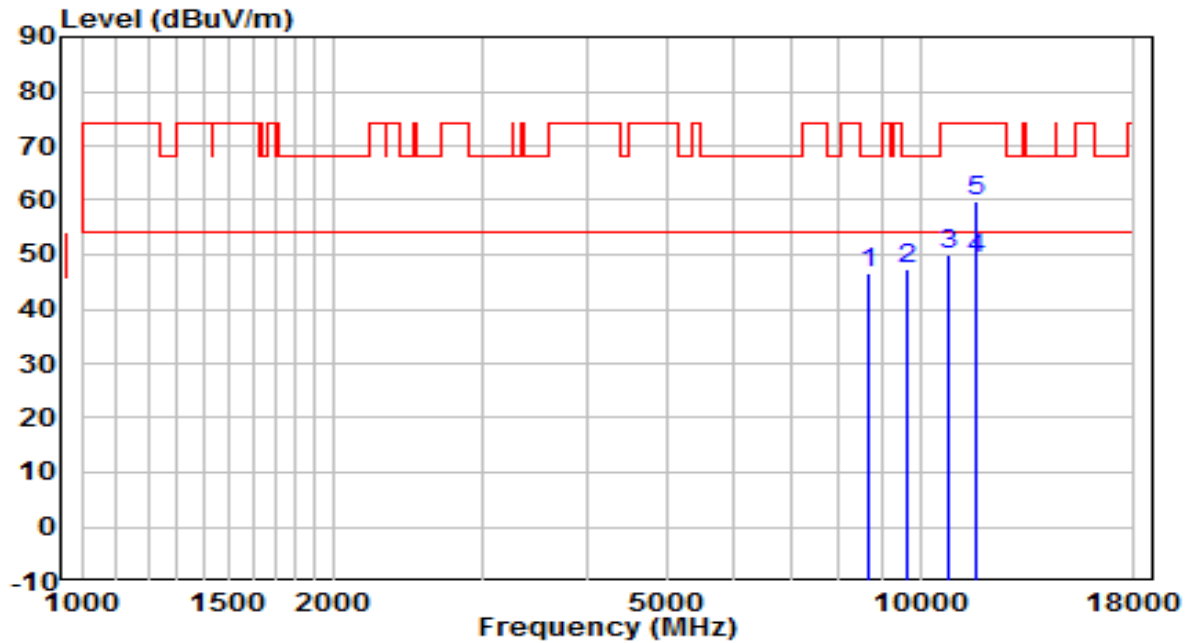

No	Frequency (MHz)	Reading (dBuV)	C.F (dB)	Measurement (dBuV/m)	Margin (dB)	Limit (dBuV/m)	Remark (QP/PK/AV)
1	8692.500	33.76	12.93	46.68	-21.52	68.20	Peak
2	9644.500	32.69	14.69	47.38	-20.82	68.20	Peak
3	10826.000	32.42	17.53	49.96	-24.04	74.00	Peak
4	* 11648.000	31.14	18.26	49.41	-4.59	54.00	Average
5	11650.500	41.47	18.26	59.73	-14.27	74.00	Peak

Note:

- "*" means this data is the worst emission level.
- C.F (Correction Factor) = Antenna Factor (dB)+ Cable Loss (dB)– Preamplifier(dB).
- Measurement(dBuV/m) = Reading(dBuV) + C.F (Correction Factor).
- The emission levels of other frequencies are very lower than the limit and not show in test report.