

FCC Radio Test Report

FCC ID: 2AXJ4EAP610V2

The worst cases of radiated emissions and maximum output power have been re-evaluated by sample of FCC ID: 2AXJ4EAP610V2, model name: EAP610. Meanwhile, the other test data were reissue from the FCC ID: 2AXJ4EAP620HDV3, model name: EAP620 HD. The test data of radiated emissions and maximum output power please see the Appendix A, Appendix B and Appendix C. Model difference(s): Only differ in DDR.

This report concerns: Original Grant

Project No. : 2111C164A
Equipment : AX1800 Ceiling Mount Wi-Fi 6 Access Point
Brand Name : tp-link
Test Model : EAP610
Series Model : N/A
Applicant : TP-Link Corporation Limited
Address : Room 901, 9/F. , New East Ocean Centre, 9 Science Museum Road, Tsim Sha Tsui, Kowloon, Hong Kong
Manufacturer : TP-Link Corporation Limited
Address : Room 901, 9/F. , New East Ocean Centre, 9 Science Museum Road, Tsim Sha Tsui, Kowloon, Hong Kong
Date of Receipt : Feb. 28, 2022
Date of Test : Mar. 01, 2022 ~ Mar. 14, 2022
Issued Date : Mar. 25, 2022
Report Version : R00
Test Sample : Engineering Sample No.: DG2022020722 for maximum output power, DG2022020723 for radiated emissions.
Standard(s) : FCC CFR Title 47, Part 15, Subpart C
FCC KDB 558074 D01 15.247 Meas Guidance v05r02
FCC KDB 662911 D01 Multiple Transmitter Output v02r01
ANSI C63.10-2013

The above equipment has been tested and found compliance with the requirement of the relative standards by BTL Inc.



Prepared by : Chella Zheng

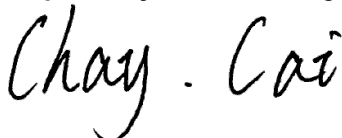

Approved by : Chay Cai



TESTING CERT #5123.02

Add: No. 3 Jinshagang 1st Rd. Shixia, Dalang Town Dongguan City, Guangdong 523792

People's Republic of China

Tel: +86-769-8318-3000

Web: www.newbtl.com

Declaration

BTL represents to the client that testing is done in accordance with standard procedures as applicable and that test instruments used has been calibrated with standards traceable to international standard(s) and/or national standard(s).

BTL's reports apply only to the specific samples tested under conditions. It is manufacture's responsibility to ensure that additional production units of this model are manufactured with the identical electrical and mechanical components. **BTL** shall have no liability for any declarations, inferences or generalizations drawn by the client or others from **BTL** issued reports.

The report must not be used by the client to claim product certification, approval, or endorsement by NVLAP, NIST, A2LA, or any agency of the U.S. Government.

This report is the confidential property of the client. As a mutual protection to the clients, the public and ourselves, the test report shall not be reproduced, except in full, without our written approval.

BTL's laboratory quality assurance procedures are in compliance with the **ISO/IEC 17025** requirements, and accredited by the conformity assessment authorities listed in this test report.

BTL is not responsible for the sampling stage, so the results only apply to the sample as received.

The information, data and test plan are provided by manufacturer which may affect the validity of results, so it is manufacturer's responsibility to ensure that the apparatus meets the essential requirements of applied standards and in all the possible configurations as representative of its intended use.

Limitation

For the use of the authority's logo is limited unless the Test Standard(s)/Scope(s)/Item(s) mentioned in this test report is (are) included in the conformity assessment authorities acceptance respective.

Please note that the measurement uncertainty is provided for informational purpose only and are not use in determining the Pass/Fail results.

Table of Contents	Page
REPORT ISSUED HISTORY	5
1 . SUMMARY OF TEST RESULTS	6
1.1 TEST FACILITY	7
1.2 MEASUREMENT UNCERTAINTY	7
1.3 TEST ENVIRONMENT CONDITIONS	7
2 . GENERAL INFORMATION	8
2.1 GENERAL DESCRIPTION OF EUT	8
2.2 DESCRIPTION OF TEST MODES	10
2.3 TEST SOFTWARE SETTING	11
2.4 DUTY CYCLE	11
2.5 BLOCK DIAGRAM SHOWING THE CONFIGURATION OF SYSTEM TESTED	12
2.6 SUPPORT UNITS	12
3 . RADIATED EMISSIONS TEST	13
3.1 LIMIT	13
3.2 TEST PROCEDURE	13
3.3 DEVIATION FROM TEST STANDARD	14
3.4 TEST SETUP	14
3.5 EUT OPERATION CONDITIONS	15
3.6 TEST RESULTS - 30 MHZ TO 1000 MHZ	15
3.7 TEST RESULTS - ABOVE 1000 MHZ	15
4 . MAXIMUM AVERAGE OUTPUT POWER	16
4.1 LIMIT	16
4.2 TEST PROCEDURE	16
4.3 DEVIATION FROM STANDARD	16
4.4 TEST SETUP	16
4.5 EUT OPERATION CONDITIONS	16
4.6 TEST RESULTS	16
5 . MEASUREMENT INSTRUMENTS LIST	17
6 . EUT TEST PHOTO	18
APPENDIX A - RADIATED EMISSION - 30 MHZ TO 1000 MHZ	20
APPENDIX B - RADIATED EMISSION- ABOVE 1000 MHZ	23

Table of Contents

Page

APPENDIX C - MAXIMUM AVERAGE OUTPUT POWER

28

REPORT ISSUED HISTORY

Report No.	Version	Description	Issued Date	Note
BTL-FCCP-1-2111C164A	R00	Original Report	Mar. 25, 2022	Valid

1. SUMMARY OF TEST RESULTS

Test procedures according to the technical standard(s):

FCC CFR Title 47, Part 15, Subpart C				
Standard(s) Section	Test Item	Test Result	Judgment	Remark
15.207	AC Power Line Conducted Emissions	-----	PASS	Note(3)
15.247(d) 15.205(a) 15.209(a)	Radiated Emissions	APPENDIX A APPENDIX B	PASS	Note(3)
15.247(a)(2)	Bandwidth	-----	PASS	Note(3)
15.247(b)(3)	Maximum Average Output Power	APPENDIX C	PASS	Note(3)
15.247(d)	Conducted Spurious Emissions	-----	PASS	Note(3)
15.247(e)	Power Spectral Density	-----	PASS	Note(3)
15.203	Antenna Requirement	-----	PASS	Note(2)

Note:

- (1) "N/A" denotes test is not applicable in this test report.
- (2) The device which used a permanently attached antenna was considered sufficient to comply with the provisions of 15.203.
- (3) Reissue from the FCC ID: 2AXJ4EAP620HDV3. Report No.: BTL-FCCP-1-2111C164.

1.1 TEST FACILITY

The test facilities used to collect the test data in this report is at the location of No. 3 Jinshagang 1st Rd. Shixia, Dalang Town Dongguan City, Guangdong 523792 People's Republic of China.

BTL's Registration Number for FCC: 357015

BTL's Designation Number for FCC: CN1240

1.2 MEASUREMENT UNCERTAINTY

ISO/IEC 17025 requires that an estimate of the measurement uncertainties associated with the emissions test results be included in the report. The measurement uncertainties given below are based on a 95% confidence level (based on a coverage factor (k=2))

The BTL measurement uncertainty as below table:

A. Radiated emissions test:

Test Site	Method	Measurement Frequency Range	Ant. H / V	U,(dB)
DG-CB03 (3m)	CISPR	30MHz ~ 200MHz	V	4.36
		30MHz ~ 200MHz	H	3.32
		200MHz ~ 1,000MHz	V	4.08
		200MHz ~ 1,000MHz	H	3.96

Test Site	Method	Measurement Frequency Range	U,(dB)
DG-CB03 (3m)	CISPR	1GHz ~ 6GHz	3.80
		6GHz ~ 18GHz	4.82

Test Site	Method	Measurement Frequency Range	U,(dB)
DG-CB03 (1m)	CISPR	18 ~ 26.5 GHz	3.62
		26.5 ~ 40 GHz	4.00

B. Other Measurement:

Test Item	Uncertainty
Maximum Output Power	±0.95 dB

Note: Unless specifically mentioned, the uncertainty of measurement has not been taken into account to declare the compliance or non-compliance to the specification.

1.3 TEST ENVIRONMENT CONDITIONS

Test Item	Temperature	Humidity	Test Voltage	Tested By
Radiated Emissions-30MHz to 1000MHz	22°C	58%	AC 120V/60Hz	Chen Mo
Radiated Emissions-Above 1000 MHz	20°C-22°C	59%	AC 120V/60Hz	Chen Mo
Maximum Average Output Power	22.2°C-22.7°C	55%-57.7%	AC 120V/60Hz	Longdage Feng

2. GENERAL INFORMATION

2.1 GENERAL DESCRIPTION OF EUT

Equipment	AX1800 Ceiling Mount Wi-Fi 6 Access Point
Brand Name	tp-link
Test Model	EAP610
Series Model	N/A
Model Difference(s)	N/A
Power Source	1# DC Voltage supplied from AC adapter. Model:T120150-2B1 2# Supplied from PoE.
Power Rating	1# I/P:100-240V~ 50/60Hz 0.6A O/P:12V \equiv 1.5A 2# 802.3at PoE: 42.5-57V \equiv 0.6A
Operation Frequency	2412 MHz ~ 2462 MHz
Modulation Type	IEEE 802.11b: DSSS IEEE 802.11g: OFDM IEEE 802.11n: OFDM IEEE 802.11ax: OFDMA
Bit Rate of Transmitter	IEEE 802.11b: 11/5.5/2/1 Mbps IEEE 802.11g: 54/48/36/24/18/12/9/6 Mbps IEEE 802.11n: up to 300 Mbps IEEE 802.11ax: up to 573.6 Mbps

Note:

- For a more detailed features description, please refer to the manufacturer's specifications or the user's manual.

2. Channel List:

CH01 - CH11 for IEEE 802.11b, IEEE 802.11g, IEEE 802.11n (HT20), IEEE 802.11ax (HE20) CH03 - CH09 for IEEE 802.11n (HT40), IEEE 802.11ax (HE40)							
Channel	Frequency (MHz)	Channel	Frequency (MHz)	Channel	Frequency (MHz)	Channel	Frequency (MHz)
01	2412	04	2427	07	2442	10	2457
02	2417	05	2432	08	2447	11	2462
03	2422	06	2437	09	2452		

3. Antenna Specification:

Ant.	Brand	Model Name	Antenna Type	Connector	Gain (dBi)
1	tp-link	N/A	PIFA	N/A	3
2	tp-link	N/A	PIFA	N/A	3

Note:

- This EUT supports CDD, and all antennas have the same gain, Directional gain = $G_{ANT} + \text{Array Gain}$.
For power measurements, Array Gain=0dB ($N_{ANT} \leq 4$), so the Directional gain=3 dBi.
For power spectral density measurements, $N_{ANT}=2$, $N_{SS} = 1$.
So the Directional gain= $G_{ANT} + \text{Array Gain} = G_{ANT} + 10\log(N_{ANT}/N_{SS})\text{dBi} = 3 + 10\log(2/1)\text{dBi} = 6.01\text{ dBi}$.
Then, the power spectral density limit is $8 - (6.01 - 6) = 7.99$.
- Beamforming Gain: 3dB. Then Directional gain=3+3=6 dBi.
- The antenna gain and beamforming gain are provided by the manufacturer.

4. Table for Antenna Configuration:
For Non Beamforming:

Operating Mode	TX Mode	2TX
IEEE 802.11b		V (Ant. 1 + Ant. 2)
IEEE 802.11g		V (Ant. 1 + Ant. 2)
IEEE 802.11n(HT20)		V (Ant. 1 + Ant. 2)
IEEE 802.11n(HT40)		V (Ant. 1 + Ant. 2)
IEEE 802.11ax(HE20)		V (Ant. 1 + Ant. 2)
IEEE 802.11ax(HE40)		V (Ant. 1 + Ant. 2)

For Beamforming:

Operating Mode	TX Mode	2TX
IEEE 802.11n(HT20)		V (Ant. 1 + Ant. 2)
IEEE 802.11n(HT40)		V (Ant. 1 + Ant. 2)
IEEE 802.11ax(HE20)		V (Ant. 1 + Ant. 2)
IEEE 802.11ax(HE40)		V (Ant. 1 + Ant. 2)

2.2 DESCRIPTION OF TEST MODES

The test system was pre-tested based on the consideration of all possible combinations of EUT operation mode.

Pretest Mode	Description
Mode 1	TX B Mode Channel 06
Mode 2	TX N-20 MHz Mode Channel 01
Mode 3	TX N-40 MHz Mode Channel 03

Following mode(s) was (were) found to be the worst case(s) and selected for the final test.

Radiated emissions test- Below 1GHz	
Final Test Mode	Description
Mode 2	TX N-20 MHz Mode Channel 01

Radiated emissions test- Above 1GHz_Non Beamforming	
Final Test Mode	Description
Mode 1	TX B Mode Channel 06
Mode 3	TX N-40 MHz Mode Channel 03

Maximum Average Output Power test_Non Beamforming	
Final Test Mode	Description
Mode 2	TX N-20 MHz Mode Channel 01

Maximum Average Output Power test_Beamforming	
Final Test Mode	Description
Mode 2	TX N-20 MHz Mode Channel 01

NOTE:

- (1) For radiated emission above 1 GHz test, the spurious points of 1GHz~26.5GHz have been pre-tested and in this report only recorded the worst case. The remaining spurious points are all below the limit value of 20dB.
- (2) IEEE 802.11ax mode only supports full RU, so only the full RU is evaluated and measured inside report.
- (3) The measurements for Output Power are tested, the Non Beamforming and Beamforming are recorded in the report. The worst case is Non Beamforming and only the worst case is documented for other test items.

2.3 TEST SOFTWARE SETTING

During testing channel & power controlling software provided by the customer was used to control the operating channel as well as the output power level.

Test Software Version	QSPR v 5.0-00188
-----------------------	------------------

2.4 DUTY CYCLE

If duty cycle is $\geq 98\%$, duty factor is not required.
 If duty cycle is $< 98\%$, duty factor shall be considered.
 The output power = measured power + duty factor.

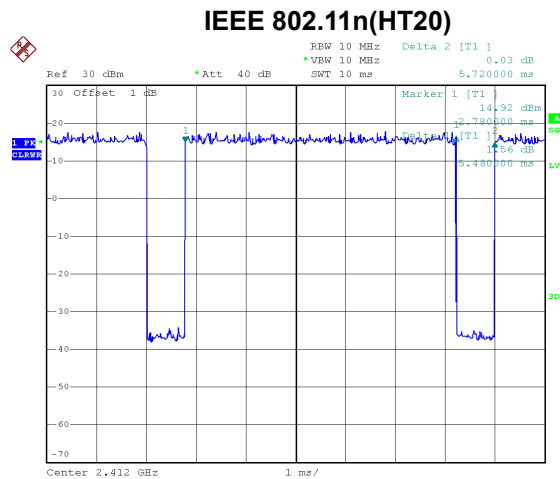

Date: 15.MAR.2022 10:03:08

Duty cycle = $5.480 \text{ ms} / 5.720 \text{ ms} = 95.80\%$
 Duty Factor = $10 \log(1/\text{Duty cycle}) = 0.19$

2.5 BLOCK DIAGRAM SHOWING THE CONFIGURATION OF SYSTEM TESTED

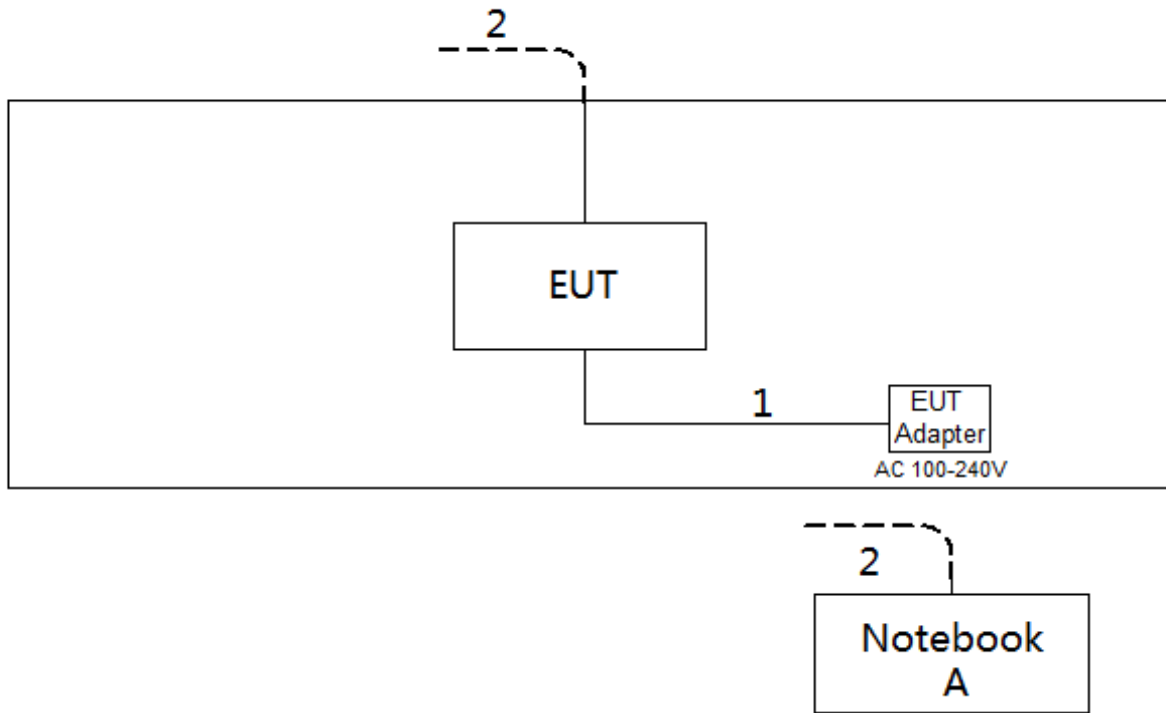

2.6 SUPPORT UNITS

Item	Equipment	Brand	Model No.	Series No.
A	Notebook	Dell	Inspiron 15-7559	N/A

Item	Cable Type	Shielded Type	Ferrite Core	Length
1	DC Cable	NO	NO	1.5m
2	RJ45 Cable	NO	NO	10m

3. RADIATED EMISSIONS TEST

3.1 LIMIT

In case the emission fall within the restricted band specified on 15.205(a), then the 15.209(a) limit in the table below has to be followed.

LIMITS OF RADIATED EMISSION MEASUREMENT (30MHz-1000 MHz)

Frequency (MHz)	Field Strength (microvolts/meter)	Measurement Distance (meters)
30-88	100	3
88-216	150	3
216-960	200	3
Above 960	500	3

LIMITS OF RADIATED EMISSION MEASUREMENT (Above 1000 MHz)

Frequency (MHz)	(dBuV/m at 3 m)	
	Peak	Average
Above 1000	74	54

NOTE:

- (1) The limit for radiated test was performed according to FCC CFR Title 47, Part 15, Subpart C.
- (2) The tighter limit applies at the band edges.
- (3) Emission level (dBuV/m)=20log Emission level (uV/m).

3.2 TEST PROCEDURE

- a. The measuring distance of 3 m shall be used for measurements. The EUT was placed on the top of a rotating table 0.8 meter above the ground at a 3 meter semi-anechoic chamber. The table was rotated 360 degrees to determine the position of the highest radiation.(below 1 GHz)
- b. The measuring distance of 3 m shall be used for measurements. The EUT was placed on the top of a rotating table 1.5 meter above the ground at a 3 meter semi-anechoic chamber. The table was rotated 360 degrees to determine the position of the highest radiation.(above 1 GHz)
- c. The height of the equipment or of the substitution antenna shall be 0.8m or 1.5m; the height of the test antenna shall vary between 1 m to 4 m. Both horizontal and vertical polarizations of the antenna are set to make the measurement.
- d. For each suspected emission, the EUT was arranged to its worst case and then the antenna was tuned to heights find the maximum reading (used Bore sight function).
- e. The receiver system was set to peak and average detect function and specified bandwidth with maximum hold mode when the test frequency is above 1 GHz.
- f. The initial step in collecting radiated emission data is a receiver peak detector mode pre-scanning the measurement frequency range. Significant peaks are then marked and then Quasi Peak detector mode re-measured.
- g. All readings are Peak Mode value unless otherwise stated AVG in column of Note. If the Peak Mode Measured value compliance with the Peak Limits and lower than AVG Limits, the EUT shall be deemed to meet both Peak & AVG Limits and then only Peak Mode was measured, but AVG Mode didn't perform. (above 1 GHz)
- h. For the actual test configuration, please refer to the related Item -EUT Test Photos.

The following table is the setting of the receiver:

Spectrum Parameters	Setting
Start ~ Stop Frequency	30 MHz~1000 MHz for RBW 100 kHz

Spectrum Parameters	Setting
Start Frequency	1000 MHz
Stop Frequency	10th carrier harmonic
RBW / VBW (Emission in restricted band)	1 MHz / 3 MHz for PK value 1 MHz / 1/T Hz for AVG value

Receiver Parameters	Setting
Start ~ Stop Frequency	30 MHz~1000 MHz for QP detector
Start ~ Stop Frequency	1 GHz~26.5 GHz for PK/AVG detector

3.3 DEVIATION FROM TEST STANDARD

No deviation

3.4 TEST SETUP

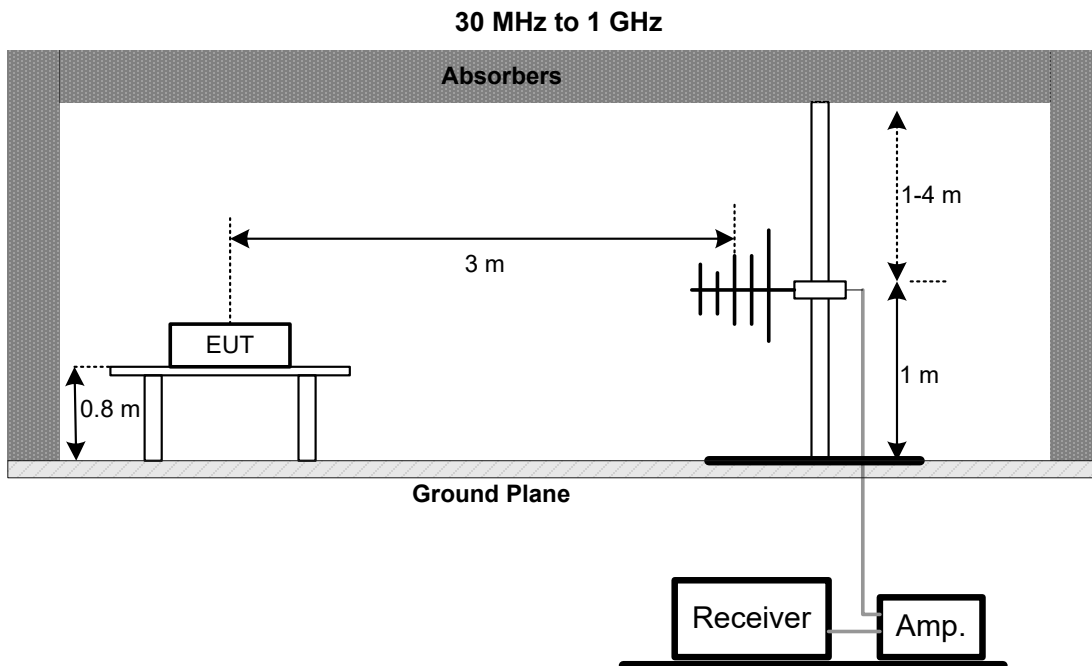

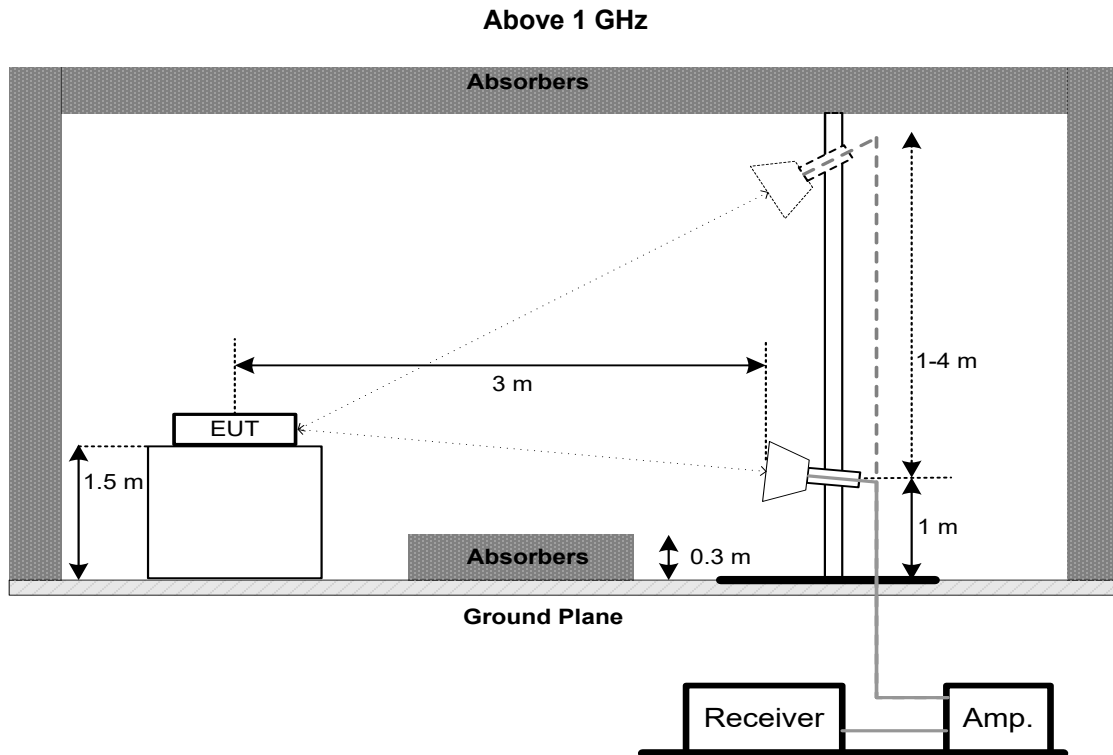

3.5 EUT OPERATION CONDITIONS

The EUT was programmed to be in continuously transmitting mode.

3.6 TEST RESULTS - 30 MHZ TO 1000 MHZ

Please refer to the APPENDIX A.

3.7 TEST RESULTS - ABOVE 1000 MHZ

Please refer to the APPENDIX B.

Remark:

- (1) No limit: This is fundamental signal, the judgment is not applicable.
For fundamental signal judgment was referred to Peak output test.

4. MAXIMUM AVERAGE OUTPUT POWER

4.1 LIMIT

Section	Test Item	Limit
FCC 15.247(b)(3)	Maximum Average Output Power	1.0000 Watt or 30.00 dBm

4.2 TEST PROCEDURE

- The EUT was directly connected to the power meter and antenna output port as show in the block diagram below.
- The maximum conducted output power was performed in accordance with method 11.9.2.3.1 of ANSI C63.10-2013 and FCC KDB 662911 D01 v02r01 Multiple Transmitter Output.

4.3 DEVIATION FROM STANDARD

No deviation.

4.4 TEST SETUP

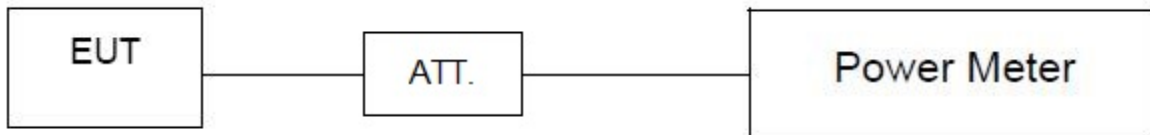

4.5 EUT OPERATION CONDITIONS

The EUT was programmed to be in continuously transmitting mode.

4.6 TEST RESULTS

Please refer to the APPENDIX C.

5. MEASUREMENT INSTRUMENTS LIST

Radiated Emissions - 30 MHz to 1000 MHz					
Item	Kind of Equipment	Manufacturer	Type No.	Serial No.	Calibrated until
1	Antenna	Schwarzbeck	VULB9160	9160-3232	Mar. 15, 2022
2	Amplifier	HP	8447D	2944A08742	Jan. 22, 2023
3	Cable	emci	LMR-400	N/A	Nov. 30, 2022
4	Controller	CT	SC100	N/A	N/A
5	Controller	MF	MF-7802	MF780208416	N/A
6	Measurement Software	Farad	EZ-EMC Ver.NB-03A1-01	N/A	N/A
7	Receiver	Agilent	N9038A	MY52130039	Jan. 22, 2023
8	966 Chamber Room	RM	9*6*6	N/A	Jul. 24, 2022

Radiated Emissions - Above 1 GHz					
Item	Kind of Equipment	Manufacturer	Type No.	Serial No.	Calibrated until
1	Double Ridged Horn Antenna	ARA	DRG-118A	16554	Apr. 21, 2022
2	Broad-Band Horn Antenna	Schwarzbeck	BBHA 9170	9170319	Jun. 30, 2022
3	Amplifier	Agilent	8449B	3008A02584	Jul. 10, 2022
4	Controller	CT	SC100	N/A	N/A
5	Controller	MF	MF-7802	MF780208416	N/A
6	Receiver	Agilent	N9038A	MY52130039	Jan. 22, 2023
7	EXA Spectrum Analyzer	Keysight	N9010A	MY56480488	Jan. 22, 2023
8	Low Noise Amplifier	CONNPHY	CLN-18G40G-4330 -K	619413	Jul. 16, 2022
9	Cable	N/A	A81-SMAMSMAM- 12.5M	N/A	Oct. 15, 2022
10	Cable	Talent microwave	A40-2.92M2.92M-2. 5M	N/A	Nov. 30, 2022
11	Filter	STI	STI15-9912	N/A	Jul. 10, 2022
12	Measurement Software	Farad	EZ-EMC Ver.NB-03A1-01	N/A	N/A
13	966 Chamber Room	RM	9*6*6	N/A	Jul. 24, 2022

Maximum Average Output Power					
Item	Kind of Equipment	Manufacturer	Type No.	Serial No.	Calibrated until
1	Peak Power Analyzer	Keysight	8990B	MY51000506	Jul. 10, 2022
2	Wideband power sensor	Keysight	N1923A	MY58310004	Jul. 10, 2022
3	Attenuator	WOKEN	6SM3502	VAS1214NL	N/A
4	RF Cable	Tongkaichuan	N/A	N/A	N/A

Remark: "N/A" denotes no model name, serial no. or calibration specified.

All calibration period of equipment list is one year.

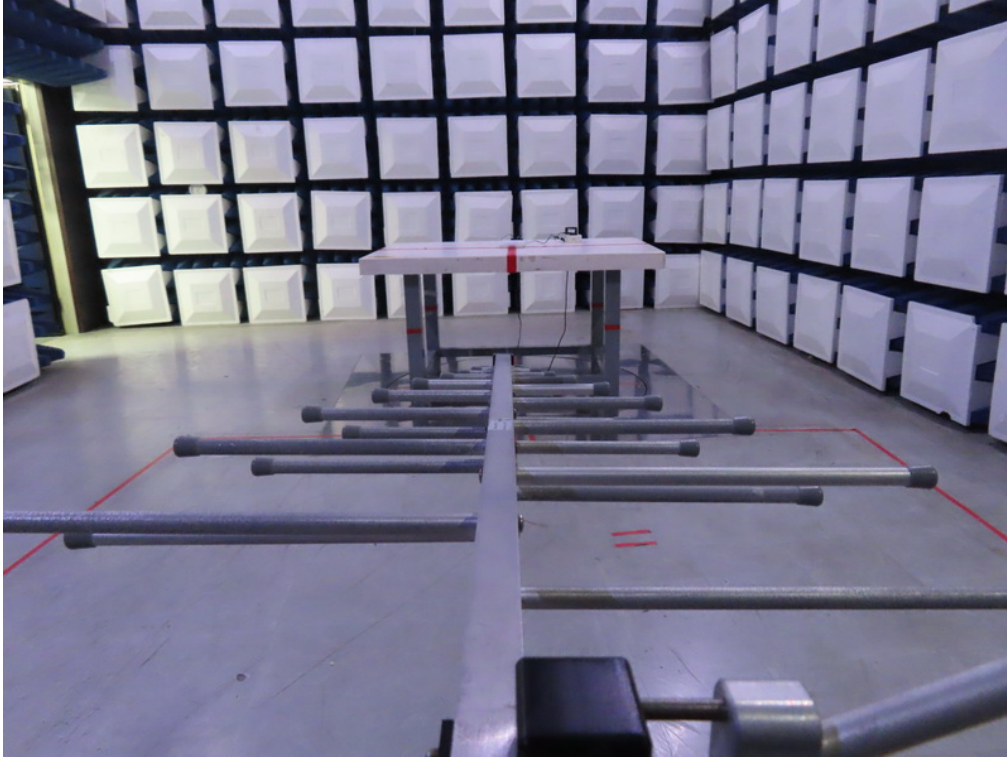
6. EUT TEST PHOTO**Radiated Emissions Test Photos****30 MHz to 1000 MHz**

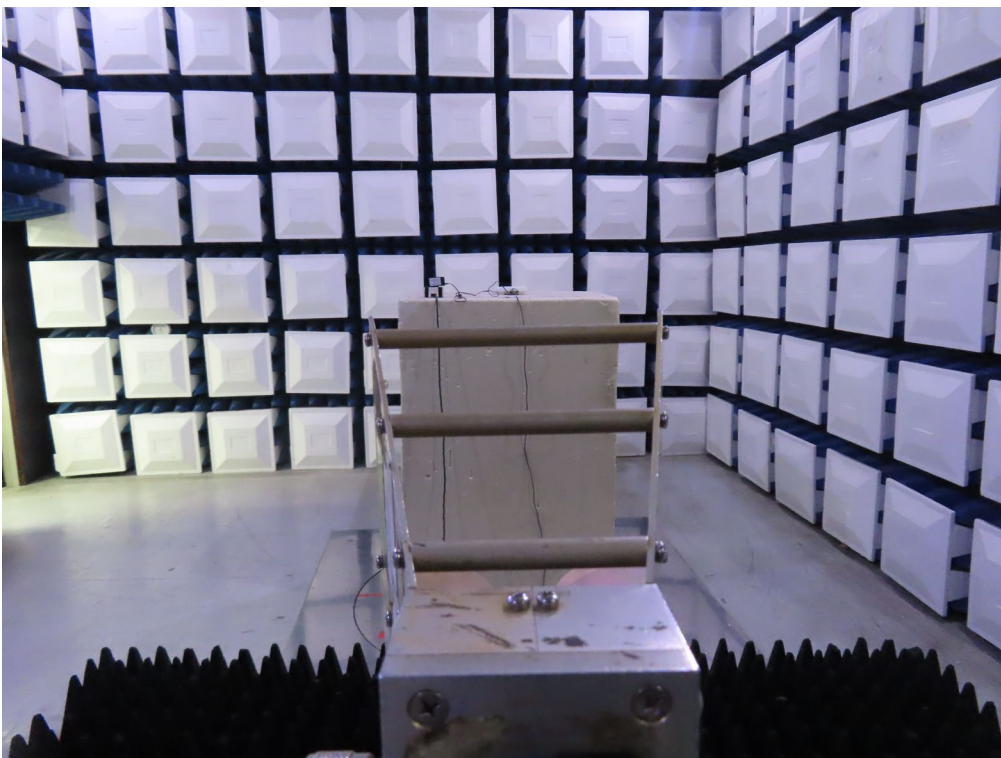
Radiated Emissions Test Photos**Above 1 GHz**

APPENDIX A - RADIATED EMISSION - 30 MHZ TO 1000 MHZ

Test Mode: TX N-20 Mode 2412 MHz

Vertical

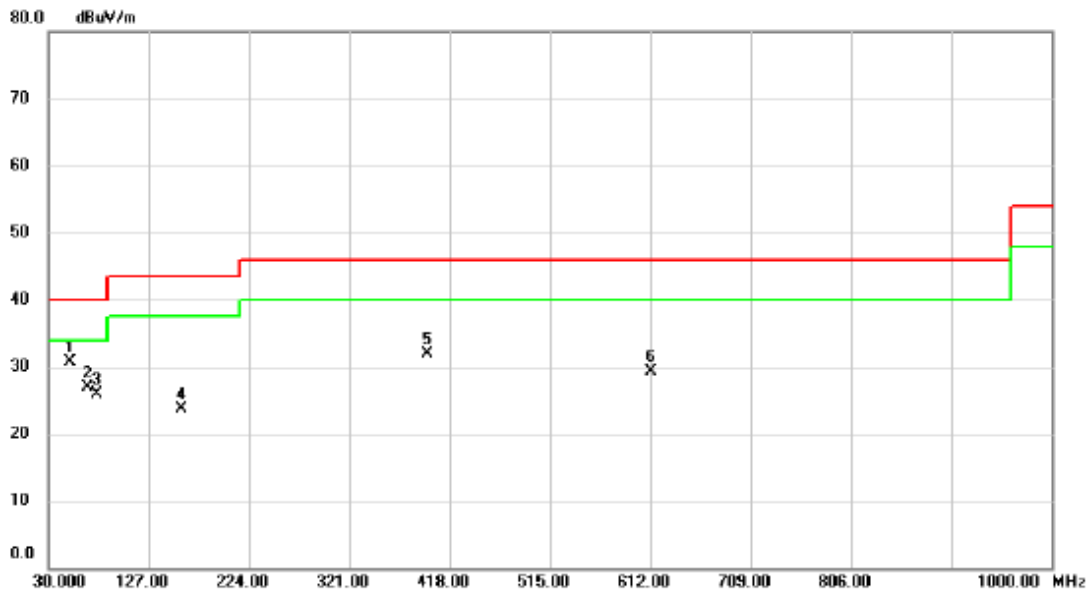

No.	Mk.	Freq. MHz	Reading Level dBuV	Correct Factor dB	Measure- ment dBuV/m	Limit dBuV/m	Margin dB	Detector	Comment
1	*	50.855	43.74	-12.95	30.79	40.00	-9.21	peak	
2		67.830	40.56	-13.64	26.92	40.00	-13.08	peak	
3		76.560	41.08	-15.26	25.82	40.00	-14.18	peak	
4		158.525	36.46	-12.74	23.72	43.50	-19.78	peak	
5		397.145	41.18	-9.23	31.95	46.00	-14.05	peak	
6		612.970	34.52	-5.14	29.38	46.00	-16.62	peak	

REMARKS:

- (1) Measurement Value = Reading Level + Correct Factor.
- (2) Margin Level = Measurement Value - Limit Value.

Test Mode: TX N-20 Mode 2412 MHz

Horizontal

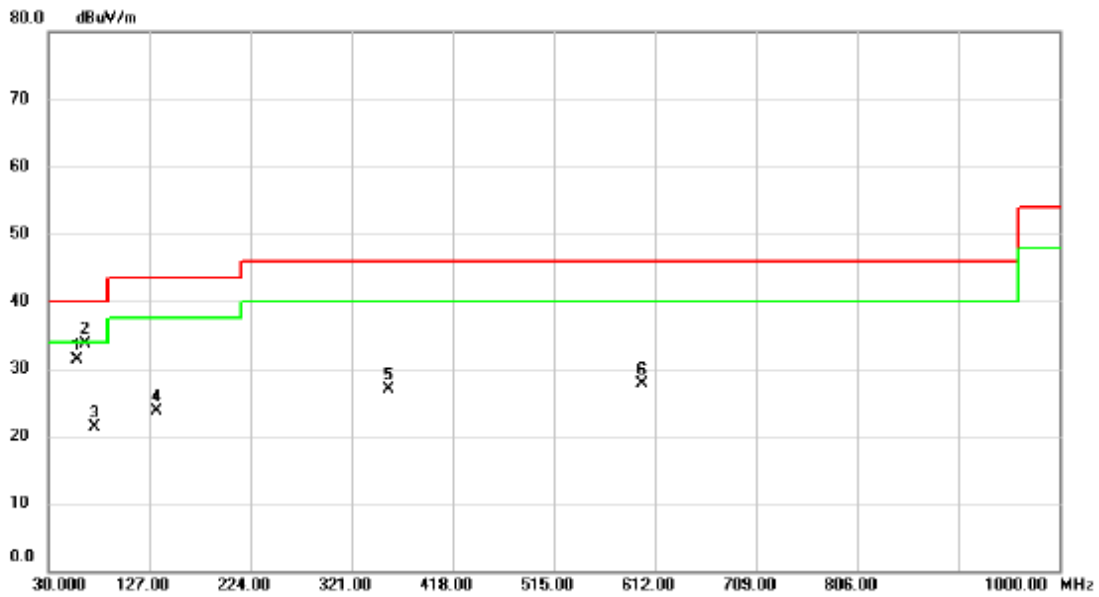

No.	Mk.	Freq. MHz	Reading Level dBuV	Correct Factor dB	Measure- ment dBuV/m	Limit dBuV/m	Margin dB	Detector	Comment
1		57.645	44.17	-12.96	31.21	40.00	-8.79	peak	
2	*	65.405	47.18	-13.43	33.75	40.00	-6.25	peak	
3		75.105	36.27	-14.94	21.33	40.00	-18.67	peak	
4		133.790	37.81	-14.20	23.61	43.50	-19.89	peak	
5		356.405	37.07	-10.19	26.88	46.00	-19.12	peak	
6		599.875	33.21	-5.46	27.75	46.00	-18.25	peak	

REMARKS:

- (1) Measurement Value = Reading Level + Correct Factor.
- (2) Margin Level = Measurement Value - Limit Value.

APPENDIX B - RADIATED EMISSION- ABOVE 1000 MHZ

Test Mode: TX B Mode 2437 MHz

Vertical

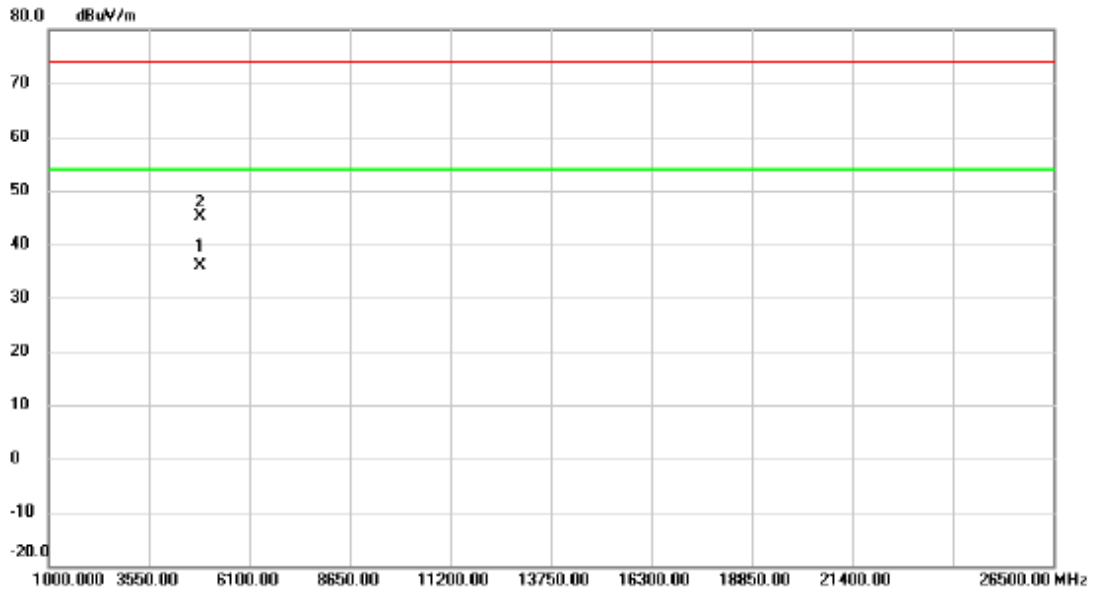

No.	Mk.	Freq. MHz	Reading Level dBuV	Correct Factor dB	Measure- ment dBuV/m	Limit dBuV/m	Margin dB	Detector	Comment
1	*	4874.020	30.41	5.48	35.89	54.00	-18.11	AVG	
2		4874.215	39.63	5.48	45.11	74.00	-28.89	peak	

REMARKS:

- (1) Measurement Value = Reading Level + Correct Factor.
- (2) Margin Level = Measurement Value - Limit Value.

Test Mode: TX B Mode 2437 MHz

Horizontal

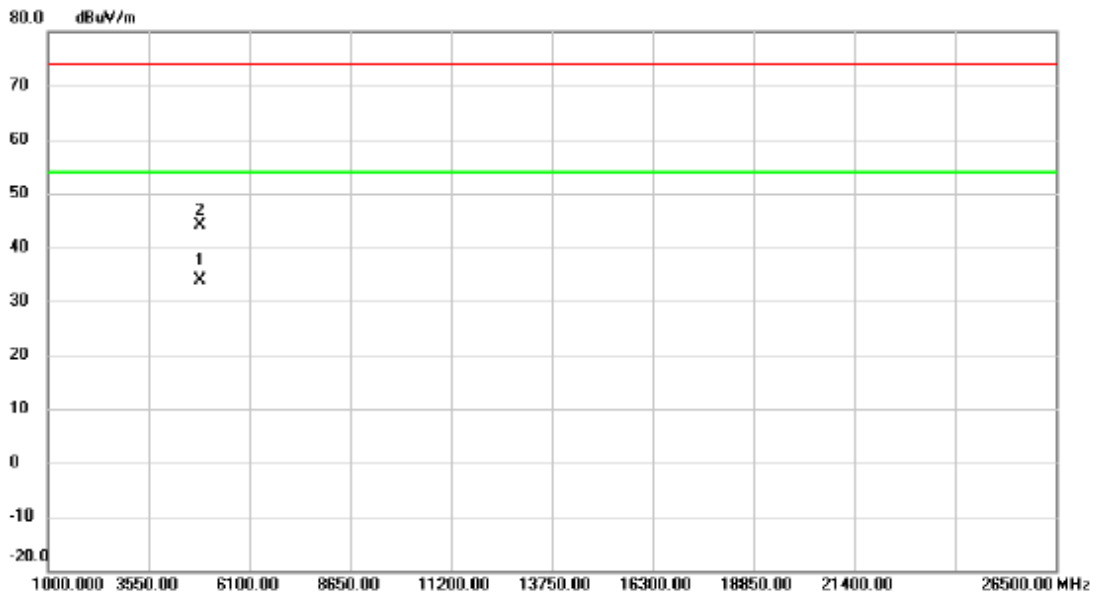

No.	Mk.	Freq. MHz	Reading Level dBuV	Correct Factor dB	Measure- ment dBuV/m	Limit dBuV/m	Margin dB	Detector	Comment
1	*	4873.775	28.32	5.48	33.80	54.00	-20.20	AVG	
2		4874.850	38.61	5.48	44.09	74.00	-29.91	peak	

REMARKS:

- (1) Measurement Value = Reading Level + Correct Factor.
- (2) Margin Level = Measurement Value - Limit Value.

Test Mode: TX N-40M Mode 2422 MHz

Vertical

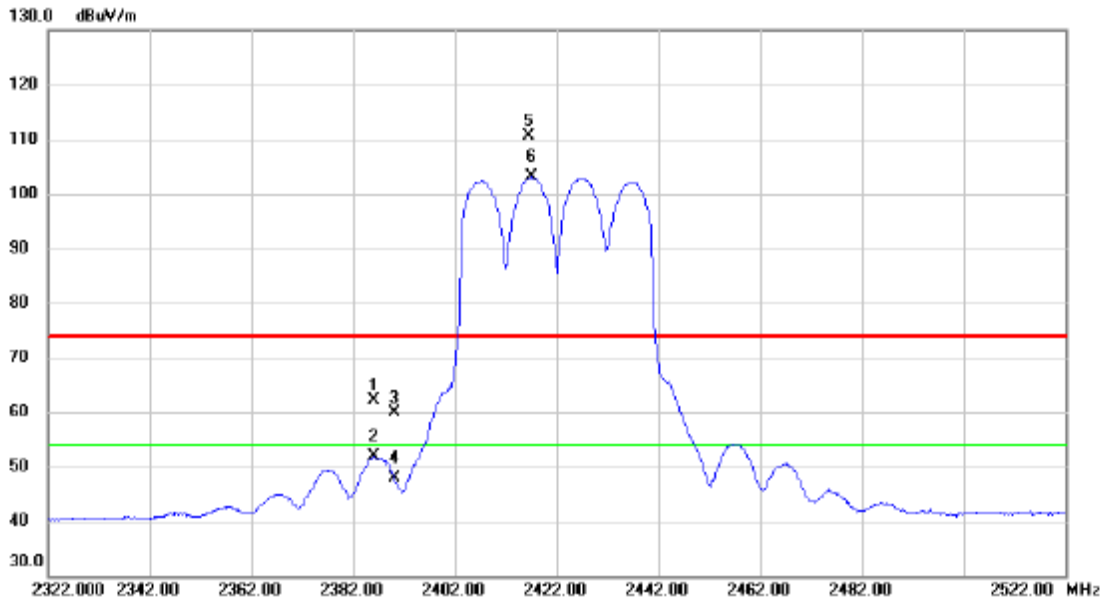

No.	Mk.	Freq.	Reading Level	Correct Factor	Measurement	Limit	Margin	Detector	Comment
		MHz	dBuV	dB	dBuV/m	dBuV/m	dB		
1		2386.000	53.81	8.29	62.10	74.00	-11.90	peak	
2		2386.000	43.58	8.29	51.87	54.00	-2.13	CAV	
3		2390.000	51.55	8.31	59.86	74.00	-14.14	peak	
4		2390.000	39.67	8.31	47.98	54.00	-6.02	AVG	
5	X	2416.600	102.39	8.34	110.73	74.00	36.73	peak	No Limit
6	*	2417.200	94.72	8.34	103.06	54.00	49.06	AVG	No Limit

REMARKS:

- (1) Measurement Value = Reading Level + Correct Factor.
- (2) Margin Level = Measurement Value - Limit Value.

Test Mode: TX N-40M Mode 2422 MHz

Horizontal



No.	Mk.	Freq. MHz	Reading Level dBuV	Correct Factor dB	Measure- ment dBuV/m	Limit dBuV/m	Margin dB	Detector	Comment
1		2384.600	52.24	8.29	60.53	74.00	-13.47	peak	
2		2384.600	40.90	8.29	49.19	54.00	-4.81	AVG	
3		2390.000	36.39	8.31	44.70	54.00	-9.30	AVG	
4	X	2413.800	99.61	8.34	107.95	74.00	33.95	peak	No Limit
5	*	2423.800	91.31	8.35	99.66	54.00	45.66	AVG	No Limit

REMARKS:

- (1) Measurement Value = Reading Level + Correct Factor.
- (2) Margin Level = Measurement Value - Limit Value.

APPENDIX C - MAXIMUM AVERAGE OUTPUT POWER

Non Beamforming

Test Mode	TX N(HT20) Mode_Ant. 1
-----------	------------------------

Channel	Frequency (MHz)	Average Output Power (dBm)	Duty Factor	Average Output Power + Duty Factor (dBm)	Max. Limit (dBm)	Max. Limit (W)	Result
01	2412	22.21	0.19	22.40	30.00	1.0000	Complies

Test Mode	TX N(HT20) Mode_Ant. 2
-----------	------------------------

Channel	Frequency (MHz)	Average Output Power (dBm)	Duty Factor	Average Output Power + Duty Factor (dBm)	Max. Limit (dBm)	Max. Limit (W)	Result
01	2412	22.39	0.19	22.58	30.00	1.0000	Complies

Test Mode	TX N(HT20) Mode_Total
-----------	-----------------------

Channel	Frequency (MHz)	Average Output Power (dBm)	Max. Limit (dBm)	Max. Limit (W)	Result
01	2412	25.50	30.00	1.0000	Complies

Beamforming

Test Mode	TX N(HT20) Mode_Ant. 1
-----------	------------------------

Channel	Frequency (MHz)	Average Output Power (dBm)	Duty Factor	Average Output Power + Duty Factor (dBm)	Max. Limit (dBm)	Max. Limit (W)	Result
01	2412	22.05	0.19	22.24	30.00	1.0000	Complies

Test Mode	TX N(HT20) Mode_Ant. 2
-----------	------------------------

Channel	Frequency (MHz)	Average Output Power (dBm)	Duty Factor	Average Output Power + Duty Factor (dBm)	Max. Limit (dBm)	Max. Limit (W)	Result
01	2412	22.09	0.19	22.28	30.00	1.0000	Complies

Test Mode	TX N(HT20) Mode_Total
-----------	-----------------------

Channel	Frequency (MHz)	Average Output Power (dBm)	Max. Limit (dBm)	Max. Limit (W)	Result
01	2412	25.27	30.00	1.0000	Complies

End of Test Report