

CREALITY

# 3D Printer User Manual

Sermoon V1 | Sermoon V1 Pro

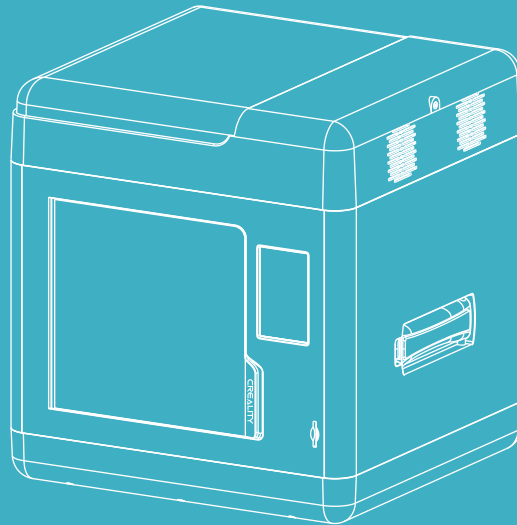

V1.0

## To Our Dear Users

Thank you for choosing Creality. To make using our products easier, please read this User Manual before you start and follow the instructions provided carefully. Creality is always ready to provide you with high-quality services. If you encounter any issues or have any questions when using our products, please use the contact information at the end of this manual to contact us.

To further enhance your user experience, you can also use the following methods to find out more about using our devices:

SD card user manual: You can find instructions and videos in the SD card provided with your device.

You can also log in to the Creality official website ([www.creality.com](http://www.creality.com)) to find information regarding software and hardware, contacts, device instructions, device warranty information, and more.

## Instructions for Use

- 1 Please do not use this device with methods and operations that have not been described in this manual to avoid accidental personal injury and property damage;
- 2 Do not place the device in flammable and explosive materials or near high heat sources. Please place the device in a ventilated and cool environment with little dust;
- 3 Do not place the printer in a vibrating or any other unstable environment. The shaking of the machine will affect the printer's printing quality;
- 4 It is recommended to use the filament recommended by the manufacturer to avoid damaging the device;
- 5 Do not use the power cable of other products as a replacement during the installation process. Please use the power cable provided with the machine. The power plug needs to be plugged into a three-hole socket with a ground wire;
- 6 To prevent moving parts from pulling the human body into the device and cause cuts and lacerations, do not wear cotton gloves while operating the printer;
- 7 To avoid burns caused by overheating of the platform, after printing, please wait for the temperature of the HotBed platform to drop before removing the model;
- 8 Please maintain the device often. When the device is unplugged, use a dry cloth to clean the printer, clean up remnants in the filament box, and check for foreign objects on the belt and endstop switch;
- 9 To avoid injuries, children under the age of 10 should not operate this device without adult supervision;
- 10 Do not manually move the nozzle or the heating platform quickly, otherwise, it may cause damage to the moving mechanisms or control circuit;
- 11 Users should abide by the laws and regulations of the corresponding country and region where the equipment is located (place of use), abide by professional ethics, and pay attention to safety obligations. The use of our products or equipment for any illegal purpose is strictly prohibited. Our company is not responsible for the relevant legal responsibilities of any violators.

<b>1. Device Description</b> .....	<b>03–04</b>
1.1 About the device .....	03–03
1.2 List of tool kit items .....	03–03
1.3 Device specifications .....	04–04
<b>2. Instructions for Use</b> .....	<b>05–14</b>
2.1 Unboxing instructions .....	05–05
2.2 Local printing .....	07–11
2.3 Cloud printing via app .....	12–15
<b>3. Notes and Daily Maintenance</b> .....	<b>16–20</b>
3.1 Changing filaments .....	16–16
3.2 Lubrication maintenance .....	17–17
3.3 Leveling the platform .....	17–18
3.4 Using and maintaining the magnetic adhesive sticker .....	19–19
3.5 Cleaning foreign objects from the chassis .....	19–19
3.6 Connecting to cloud print .....	20–20

## Device Description

### 1.1 About the device

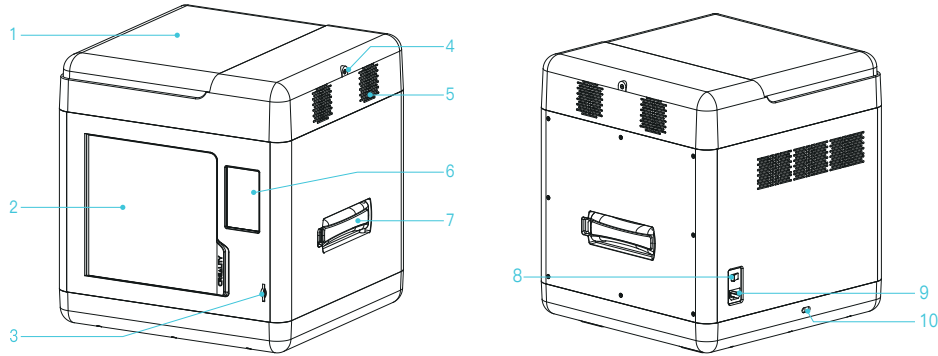

1. Cover	6. Display screen
2. Front door	7. Rack
3. SD card slot	8. Power switch
4. Filament entrance	9. Power socket
5. Ventilation fan	10. Voltage adjustment port

### 1.2 List of tool kit items



Filament x1



Power cable x1



Wrench and screwdriver x1



Cutting plier x1



Nozzle x1



Leveling card x1



Nozzle cleaner x1



Card reader and SD card x1



grease x1  
(For lubricating the bearings)



Glue stick x1  
(Can be used directly on the printing platform to increase adhesiveness and prevent models from wrapping)



M6 socket wrench x1



Note: The components above are for references only. The actual product may vary.

## 1.3 Device specifications

Basic Parameters	
Model	Sermoon V1   Sermoon V1 Pro
Modeling size	175x175x165 mm
Modeling technology	FDM
Number of nozzles	1
Nozzle diameter	0.4 mm (Standard)
Accuracy	± 0.1 mm
Print materials	1.75 mm PLA / ABS / PETG
Supported slicing file formats	STL / OBJ / AMF
Power rating	150W
HotBed temperature	≤ 80°C
Nozzle temperature	≤ 250°C
Ambient temperature	10°C – 30°C
Power Loss Recovery	Yes
Filament detection	Yes
Supported slicing software	Creality Slicer, Repetier-Host, Cura, Simplify3D
Printing methods	Locally via SD card or cloud printing via Wi-Fi
Power specifications	100–120Vac 200–240Vac 50/60Hz
Operating systems	Windows XP / Vista / 7 / 10/ MAC / Linux
Printing speed	≤ 150 mm/s, normally between 30–60 mm/s
Open door sensor	Comes standard with the Pro version
Camera	Comes standard with the Pro version

## 2. Instructions for Use

### 2.1 Unboxing instructions



#### Notes

- Please ensure the correct position for the power supply switch and mains before supply connection, in order to avoid damage to the device.
- If the mains between 100V and 120V, please select the 115V for the power supply switch.
- If the mains between 200V and 240V, please select the 230V for the power supply switch (default is 230V).

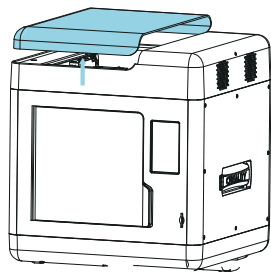

A. Open the device's cover.

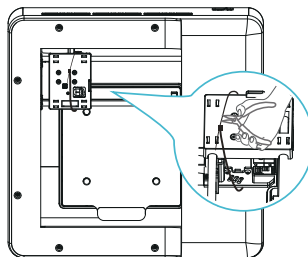

B. Use the cutting plier to cut the cable ties around the nozzle.

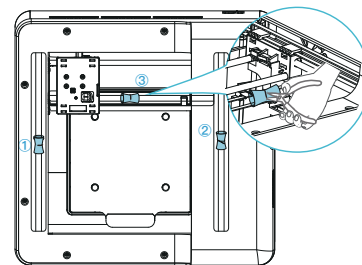

C. Use the cutting plier to cut off the cable ties on the X-axis and Y-axis belts, and remove the cut cable ties and foam.

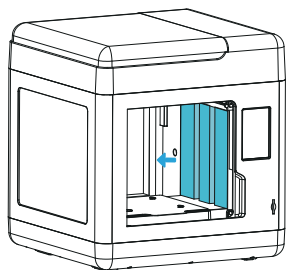

D. Remove the foam from the inside of the device.

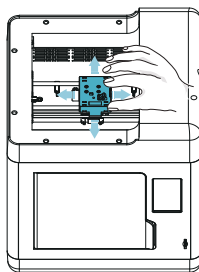

E. Check whether the moving mechanisms are moving smoothly.

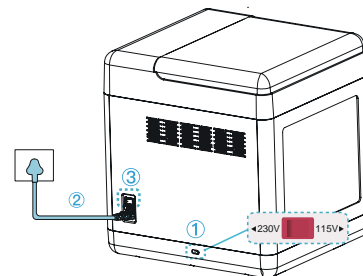

F. Note: Please ensure that the voltage matches the power supply switch, otherwise the power supply may be damaged or burnt out.

## Local printing

## Cloud printing

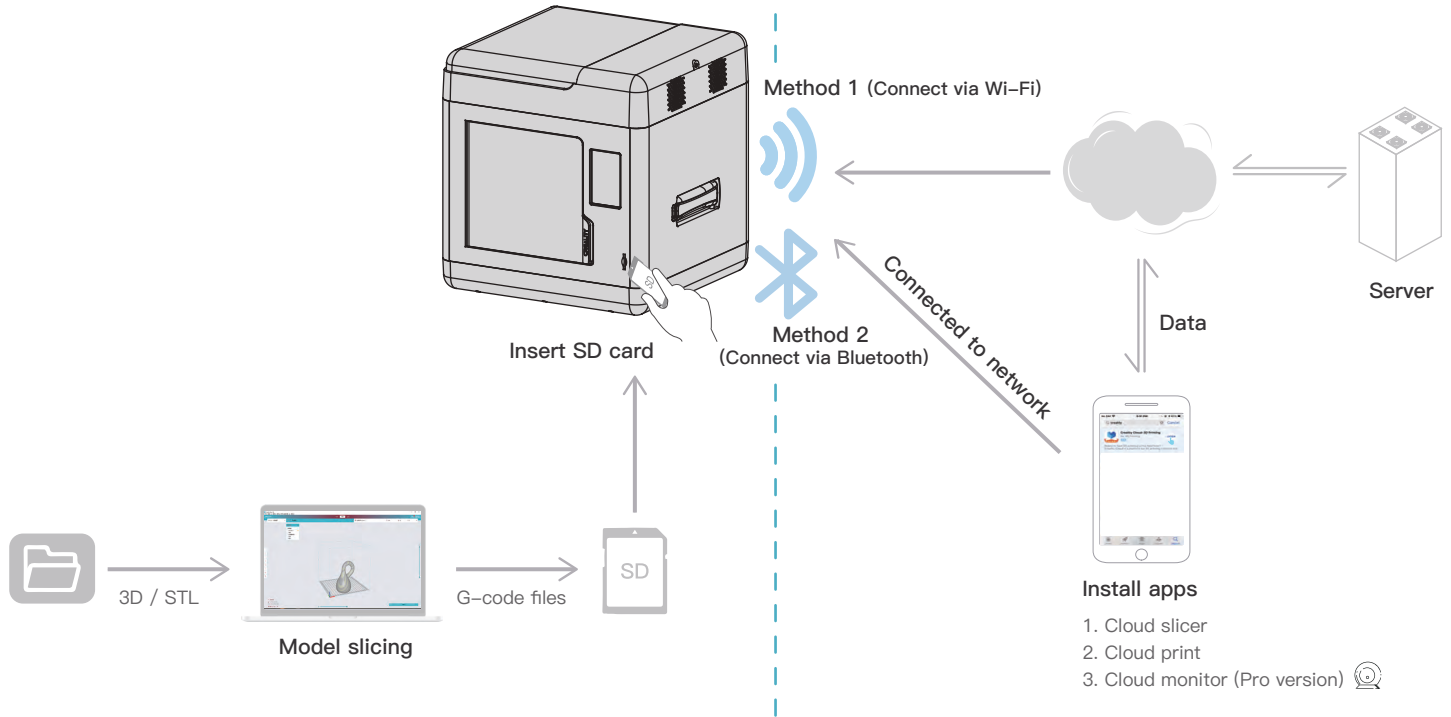

## 2.2 Local printing

### 2.2.1 Install slicer



This manual only introduces the installation of Creality slicer software. If users use other slicer software, we recommend to set the retraction parameter to 3mm to avoid the risk of plugging.



Creality Slicer



1. Please login official Creality website ([www.creality.com](http://www.creality.com)) to download the latest Creality Slicer software.

2. Select Preferences in sequence → Configure Creativity → Next → Select corresponding language → Next → Finish to complete the setting.

3. Select the current model.



Creality Slicer



4. Open Creality Slicer.

5. Load File

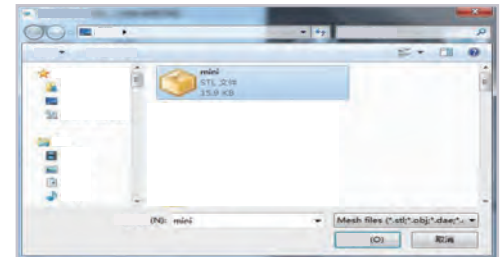

6. Select File





7. Generate G code → Save to memory card

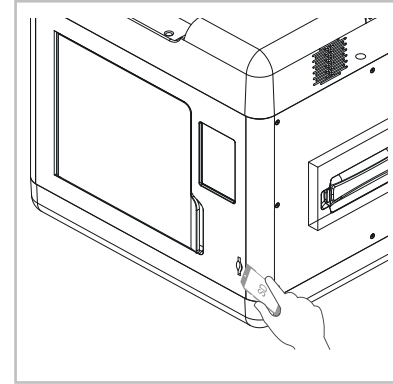

8. Insert Memory Card

It is important to note file name within the memory card must be in Latin letters or numbers. Chinese characters or any other special symbol cannot be display by the printer.

Note: For details on using the software, please refer to the slicing software user manual on the SD card.

## 2.2.2 Setup wizard

When using the printer for the first time, please reset the printer to zero. If this procedure fails, please turn off the power and contact after-sales.



Note: The above interface is for reference only. The actual UI may vary.

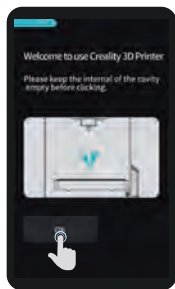

1. No foreign objects on the printing platform

2. Return to zero self-test

3. Install filament



4. Load filament

5. Insert SD card

## 2.2.3 Printing modes

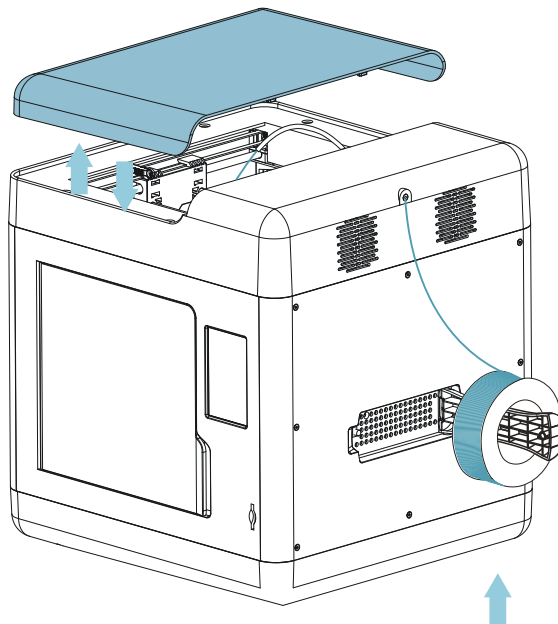
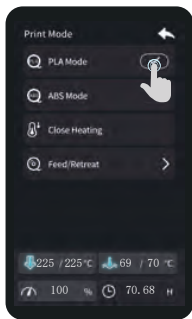
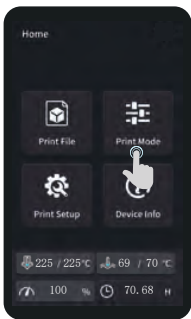

1. PLA mode: As our company recommends the PLA mode, the system's parameters have been set according to PLA filaments. It is recommended to use Creality filaments for printing. When the inside the box temperature exceeds 30°C, please open the top cover to avoid nozzle blockage.

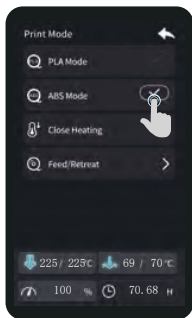
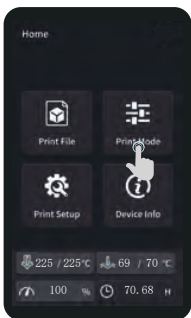

2. ABS mode: As our company recommends the ABS mode, the system's parameters have been set according to ABS filaments. It is recommended to use Creality filaments for printing. When printing, please ensure that the top cover is on to keep the device's temperature inside.



Note: When printing with ABS filaments, it is recommended that the size of a single model be controlled within 100 x 100 mm (length x width) to avoid warping caused by the characteristics of the filaments, which can result in printing failure.



Note: Please install the filaments as shown in the figure above.

## 2.2.4 Start printing

In this order, go to Print files → Select file → Print.



Note: The above interface is for reference only. The actual UI may vary.

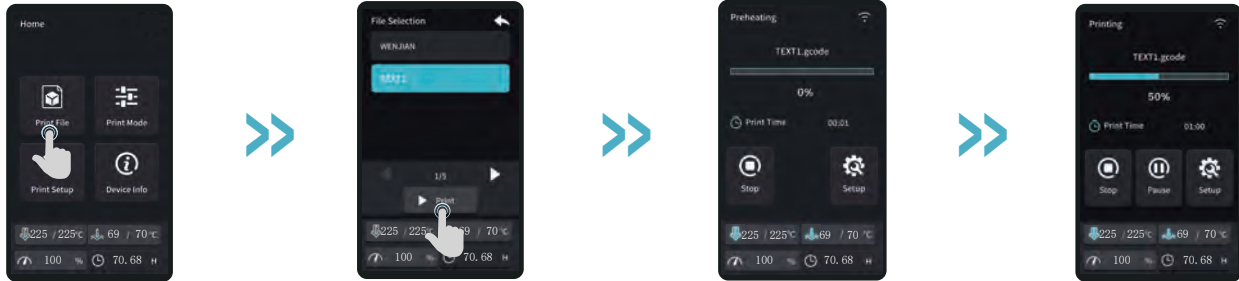

## 2.2.5 Automatic open door check function (Pro version only)

To prevent the accidental opening of the door and cause burns and mechanical injuries, please turn on the pause door opening function (this function is enabled by default).

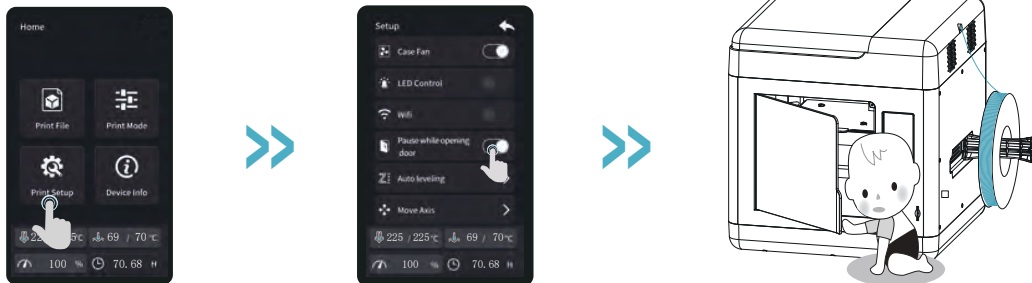

## 2.3 Cloud printing via app

### 2.3.1 Install app



1. Scan the QR code to download the app



2. Download



3. Create account



4. Log in

### 2.3.2 Connect to the network and cloud printing (Method 1: Connect via Wi-Fi)

As shown below, please use your smartphone to select your device model and slicing:



Note: When cloud printing via the app, be sure to uncheck the PLA mode and ABS mode on the device, otherwise the app cannot control the device temperature.



1. Add device

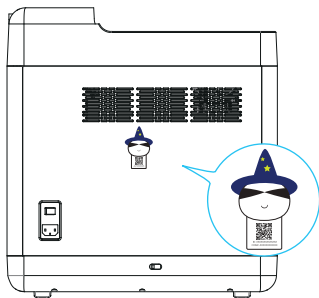

2. Scan the QR on the device



3. Network settings



4. Connect to device Wi-Fi

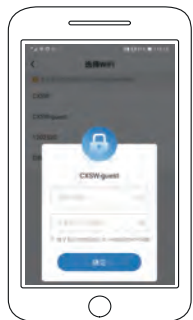

5. Connect to user Wi-Fi



6. New device added



7. Find model



8. Model slicing



9. Print via a network connection

### 2.3.3 Connect to the network and cloud printing (Method 2: Connect via Bluetooth)

As shown below, please use your smartphone to select your device model and slicing:



Note: When cloud printing via the app, be sure to uncheck the PLA mode and ABS mode on the device, otherwise the app cannot control the device temperature.



1. Add device



2. Search for Bluetooth device  
(Turn on Bluetooth on your smartphone)



3. Add device

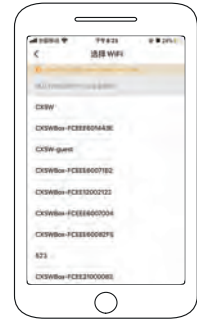

4. Select user Wi-Fi

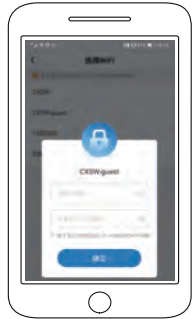

5. Connect to user Wi-Fi



6. New device added



7. Find model



8. Model slicing



9. Print via a network connection

### 2.3.4 Cloud monitor (Pro version only)



Note: Open the camera interface on the app, and both cloud printing and local printing can be viewed remotely using the camera. The LED light will also automatically turn on in environments with poor light.

Method 1:

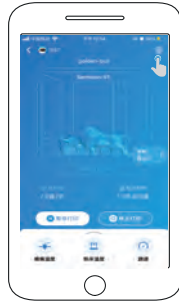

1. Click

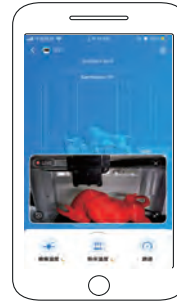

2. Real-time monitoring

Method 2:



1. Click



2. Real-time monitoring



### 3. Notes and Daily Maintenance

#### 3.1 Feed out and feed in filaments

 Note: The above interface is for reference only. The actual UI may vary.

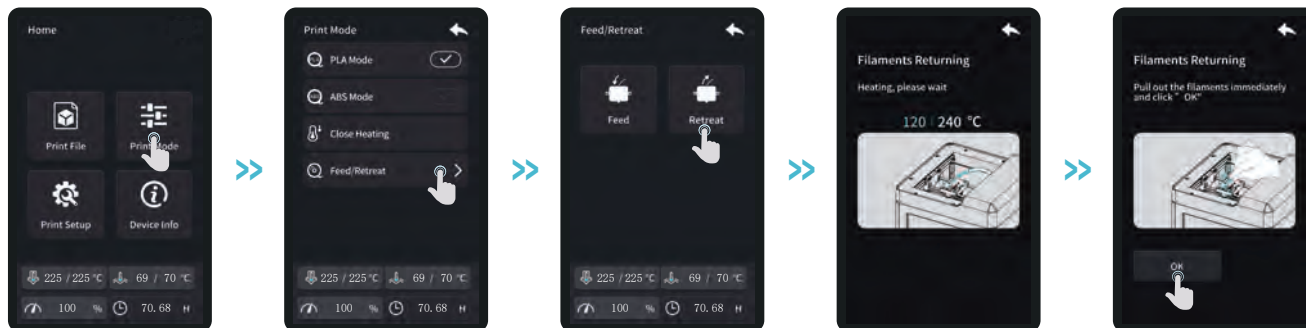

 Once the specific temperature has been reached and filaments are withdrawing, please immediately pull out the filaments. Otherwise, the filaments may jam up once it has cooled down.

### 3.2 Lubrication maintenance



Note: Please perform regular maintenance on the blue area using oil and lubrication (as shown in the figure).

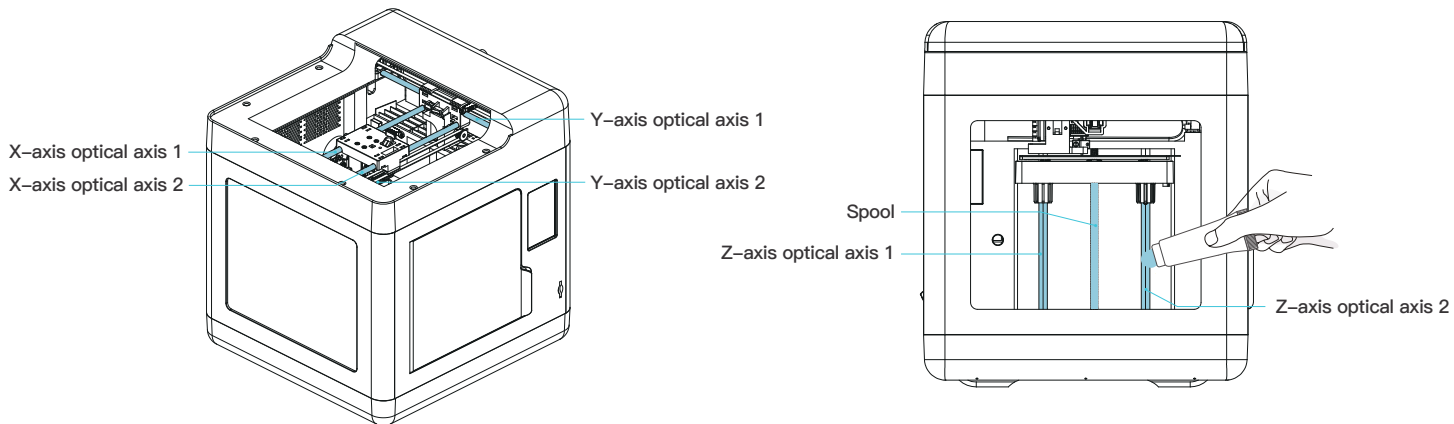

### 3.3 Leveling the platform



Note: After using the printer for a long time, the distance between the platform and the nozzle may change, which could cause the adhesion of the first layer of the model to become weak and cause a printing failure. Please level the platform regularly.



You can use the leveling card provided to help with the leveling. The nozzle should be just able to scratch the leveling card. Keep adjusting them until you can feel a slight resistance from the nozzle when you pull the leveling card.



Note: The nozzle is a damageable part. If the nozzle becomes heavily worn out, please replace it regularly.

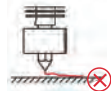
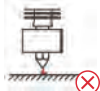
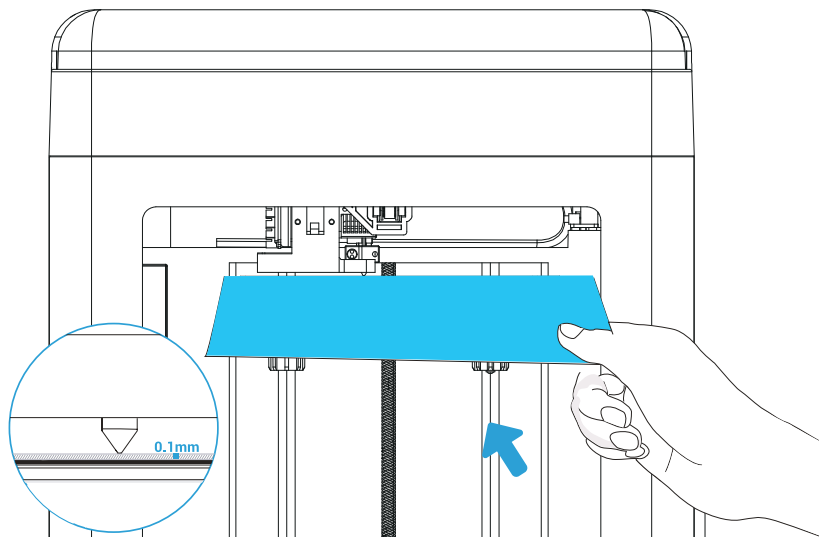

The nozzle is too far away from the platform, and the filaments cannot stick to the platform.



The filaments are evenly spread out and are sticking to the platform just right.



The nozzle is too close to the platform, and the filaments are not extruded enough, which may damage the platform.

### 3.4 Using and maintaining the magnetic adhesive sticker

 Note: The printing platform is a damageable part. Please replace it regularly to ensure the adhesion of the first layer model.

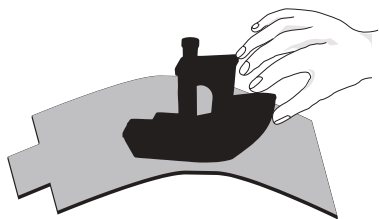

1. Take the printed model and platform out of the device together, and partially bend the platform slightly to separate the model from the platform. (The platform is not easy to bend to prevent the platform from deforming and becoming unusable)



2. The filament residue on the platform can be scraped off with a small household blade. Please pay attention to safety when using it.

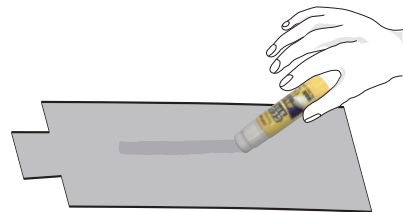

3. If the adhesion of the first layer of the model is weak, please apply a glue stick evenly onto the surface of the platform.

### 3.5 Cleaning foreign objects from the chassis

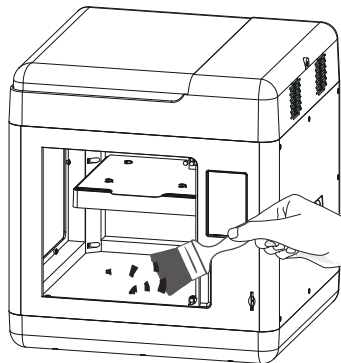

1. Remove any foreign objects from the inside of the device.

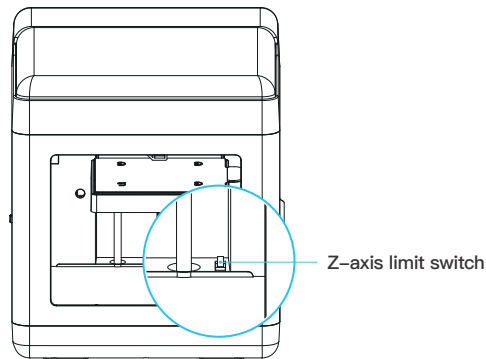

2. Check whether there is any foreign object remaining on the Z-axis limit switch to prevent the Z-axis limit switch from getting stuck.

## 3.6 Connecting to cloud print

 Note: If the network configuration is unsuccessful or you need to re-bind your smartphone, please follow the steps below.

1. It is recommended to use the small wrench in the accessory package to enter the rack's reset hole and long-press the reset switch for six seconds before releasing;

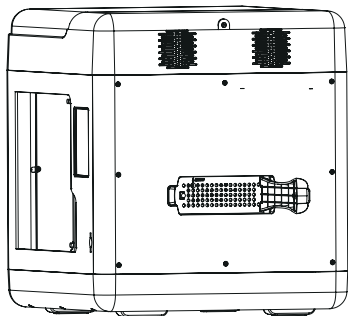

① Long-press for six seconds

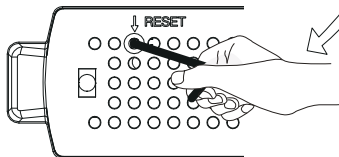

2. Once the Wi-Fi indicator light turns off, the system will automatically enable the yellow indicator light. When the yellow light starts flashing, that means reset has been completed;

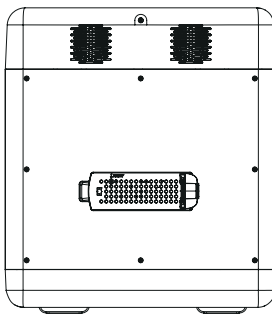

② Yellow light starts flashing again

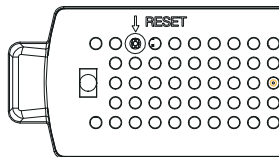

3. Once the Wi-Fi has been successfully reset, use your smartphone to scan the QR code on the back of the device again to connect it to the network. You can also use a Bluetooth connection instead;

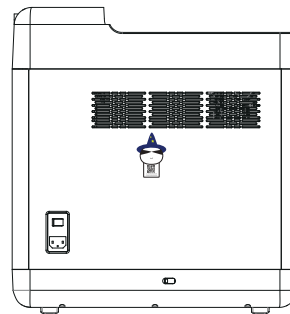

③ Connect via Wi-Fi or Bluetooth



#### U.S. FCC Part 15 Regulatory Information:

This equipment complies with radiation exposure limits set forth for an uncontrolled environment. This transmitter must not be co-located or operating in conjunction with any other antenna or transmitter. This equipment should be installed and operated with minimum distance 20cm between the radiator & your body.

This device complies with part 15 of the FCC Rules. Operation is subject to the following two conditions:

- (1) This device may not cause harmful interference, and
- (2) This device must accept any interference received, including interference that may cause undesired operation.

Any Changes or modifications not expressly approved by the party responsible for compliance could void the user's authority to operate the equipment.

Note: This equipment has been tested and found to comply with the limits for a Class B digital device, pursuant to part 15 of the FCC Rules. These limits are designed to provide reasonable protection against harmful interference in a residential installation. This equipment generates, uses and can radiate radio frequency energy and, if not installed and used in accordance with the instructions, may cause harmful interference to radio communications. However, there is no guarantee that interference will not occur in a particular installation. If this equipment does cause harmful interference to radio or television reception, which can be determined by turning the equipment off and on, the user is encouraged to try to correct the interference by one or more of the following measures:

- Reorient or relocate the receiving antenna.
- Increase the separation between the equipment and receiver.
- Connect the equipment into an outlet on a circuit different from that to which the receiver is connected.
- Consult the dealer or an experienced radio/TV technician for help.

#### Canada Regulatory Information :

CAN ICES-3 (B)/NMB-3(B)

This device contains licence-exempt transmitter(s)/receiver(s) that comply with Innovation, Science and Economic Development Canada's licence-exempt RSS(s). Operation is subject to the following two conditions:

- (1) This device may not cause interference.
- (2) This device must accept any interference, including interference that may cause undesired operation of the device.

L' émetteur/récepteur exempt de licence contenu dans le présent appareil est conforme aux CNR d' Innovation, Sciences et Développement économique Canada applicables aux appareils radio exempts de licence. L' exploitation est autorisée aux deux conditions suivantes :

- 1) L' appareil ne doit pas produire de brouillage;
- 2) L' appareil doit accepter tout brouillage radioélectrique subi, même si le brouillage est susceptible d' en compromettre le fonctionnement.

Après examen de ce matériel aux conformité ou aux limites d' intensité de champ RF, les utilisateurs peuvent sur l' exposition aux radiofréquences et la conformité and compliance d' acquérir les informations correspondantes. La distance minimale du corps à utiliser le dispositif est de 20cm.

For pluggable equipment, the socket-outlet shall be easily accessible.  
Pour l'équipement pluggable, la prise de prise doit être facilement accessible.

Do not use this apparatus near water.  
Ne pas utiliser cet appareil à proximité des sources d'eau.

Clean only with dry cloth.  
Nettoyer seulement avec un chiffon doux sec.

Only use attachment/accessories specified by the manufacturer.  
N'utiliser que des accessoires recommandés par le fabricant.

Unplug this apparatus during lightning storms or when unused for long periods of time.  
Débrancher l'appareil durant les orages ou lorsque non utilisé pendant de longues périodes.

Refer all servicing to qualified service personnel. Servicing is required when the apparatus has been damaged in any way, such as power-supply cord or plug is damaged, liquid has been spilled or objects have fallen into the apparatus, the apparatus has been exposed to rain or moisture, does not operate normally, or has been dropped.

Confier la réparation à du personnel technique qualifié. Faire réparer lorsque l'appareil est endommagé; lorsque le cable ou la fiche d'alimentation est endommagé, lorsqu' on a renversé du liquide ou si des objets sont tombés dans l'appareil, lorsque l'appareil a été exposé à de la pluie ou à de l'humidité, si l'appareil ne fonctionne pas normalement, ou lorsqu'il est tombé.

Internal/External Voltage Selectors : Internal or external voltage selector switches, if any, should only be reset and re-equipped with a proper plug for alternative voltage by a qualified service technician. Do not attempt to alter this yourself.

Sélecteurs de tension interne/externe : Les sélecteurs de tension interne ou externe, s'il y en a, doivent être réinitialisés et équipés avec une fiche adéquate par un technicien qualifié. Ne jamais tenter de modifier ceci vous-même.

Protective earthing terminal : The apparatus should be connected to a mains socket outlet with a protective earthing connection.

Borne de terre de protection : Par mesure de sécurité, l'appareil doit être branché à une prise decourant comprenant une borne de mise à la terre.

When moving or not using the appliance, secure the power cord (e.g., wrap it with a cable tie). Be careful not to damage the power cord. Before using it again, make sure the power cord has not been damaged. If the power cord has been damaged at all, bring the unit and cord to a qualified service technician for repair or replacement as specified by the manufacturer.

Veillez à toujours fixer le cable d' alimentation lors du déplacement de l'appareil ou lorsqu' il n'est pas utilisé.Veillez à ne pas endommager le cable d' alimentation. Vérifiez toujours le cable d'alimentation avant d' utiliser l'appareil. Si le cable d'alimentation est endommagé de quelque façon, faites vérifier l'appareil et le cable d'alimentation par un technicien qualifié recommandé par le fabricant afin de les faire réparer ou replacer.

Disconnect power cord before servicing.  
Déconnectez l'appareil avant le service.

Replace critical components. only with factory parts or recommended equivalents.

Remplacez les composants seulement avec des composants de la fabrique ou avec des équivalents recommandés.

CAUTION: TO REDUCE THE RISK OF ELECTRIC SHOCK, DO NOT REMOVE ANY COVER. NO USER- SERVICEABLE PARTS INSIDE. REFER SERVICING TO QUALIFIED SERVICE PERSONNEL ONLY.

CAUTION: POUR REDUIRE LE RISQUE DE CHOQUE ELECTRIQUE N'ELOIGNEZ PAS LA COUVERTURE. PAS DE COMPONENTS UTILISABLES AU SERVICE A L'INTERIEUR. DEMANDEZ SERVICE SEULEMENT AU PERSONNEL QUALIFIE.

EU Regulatory Information:



Support Frequency Bands and Power:

WLAN /BT 2.4 GHz < 20 dBm;

The simplified EU declaration of conformity referred to in Article 10(9) shall be provided as follows:

Hereby, [Shenzhen Crealty 3D Technology Co., Ltd.] declares that the radio equipment type [Sermoon V1 Pro, Sermoon V1] is in compliance with Directive 2014/53/EU.

The full text of the EU declaration of conformity is available at the following internet address: <https://www.crealty.com/>



Each model is different. All images are for illustrative purposes only, and the actual product may vary. The final interpretation right belongs to Shenzhen Crealty 3D Technology Co., Ltd.



**SHENZHEN CREALTY 3D TECHNOLOGY CO.,LTD.**

18F, JinXiuHongDu Building, Meilong Blvd., Longhua Dist., Shenzhen,  
China 518131

Official Website: [www.crealty.com](http://www.crealty.com)

Tel: +86 755-8523 4565

E-mail: [info@creality.com](mailto:info@creality.com) [cs@creality.com](mailto:cs@creality.com)



R 210-170942

