



CREALITY

CREATE REALITY, ACHIEVE DREAMS

CR-M4

CR-M4

3D Printer User Manual

V1.0

To Our Dear Users

Thank you for choosing Creality. To make using our products easier, please read this User Manual before you start and follow the instructions provided carefully.

Creality is always ready to provide you with high-quality services. If you encounter any issues or have any questions when using our products, please use the contact information at the end of this manual to contact us.

To further improve your user experience, you can find more about our devices via the following methods:

User manual: You can find instructions and videos in the SD card provided with the printer.

You can also visit our official website (<https://www.creality.com>) to find information regarding software, hardware, contact information, device instructions, device warranty information, and more.

Firmware Upgrade

Please visit our official website <https://www.creality.com/download>, switch to your language, then select your printer and model. Download the required firmware and install it to use it with your printer.

NOTES

- 1 Do not use the printer any way other than described here in order to avoid personal injury or property damage.
- 2 Do not place the printer near any heat source or flammable or explosive objects. We suggest placing it in a well-ventilated, low-dust environment.
- 3 Do not expose the printer to violent vibration or any unstable environment, as this may cause poor print quality.
- 4 Before using experimental or exotic filaments, we suggest using standard filaments such as ABS or PLA to calibrate and test the machine.
- 5 Do not use any other power cable except the one supplied. Always use a grounded three-prong power outlet.
- 6 Do not touch the nozzle, hotbed or motor while the printer is in operation, otherwise you may get burned.
- 7 Do not wear gloves or loose clothing when operating the printer. Such cloths may become tangled in the printers moving parts leading to burns, possible bodily injury, or printer damage.
- 8 When cleaning debris from the printer hotend, always use the provided tools. Do not touch the nozzle directly when heated. This can cause personal injury.
- 9 Clean the printer frequently. Always turn the power off when cleaning, and wipe with a dry cloth to remove dust, adhered printing plastics or any other material off the frame, guide rails, or wheels. Use glass cleaner or isopropyl alcohol to clean the print surface.
- 10 Children under 10 years old should not use the printer without supervision.
- 11 This machine is equipped with a security protection mechanism. Do not manually move the nozzle or printing platform mechanism manually while booting up, otherwise the device will automatically power off for safety.
- 12 Users should comply with the laws and regulations of the corresponding countries and regions where the equipment is located (used), abide by professional ethics, pay attention to safety obligations, and strictly prohibit the use of our products or equipment for any illegal purposes. Creality will not be responsible for any violators' legal liability under any circumstance.

Contents



Equipment Introduction	01-01
Equipment Parameters	02-02
Parts List	03-03
Product Installation	04-09
Equipment Connecting	10-10
Adjusting Pulley tightness	11-11
Auto Leveling	12-13
Filament Infill	14-15
Start Printing	16-17
Print Method	18-20
Routine Maintenance	21-22
Circuit Connecting	23-23

1. Equipment Introduction

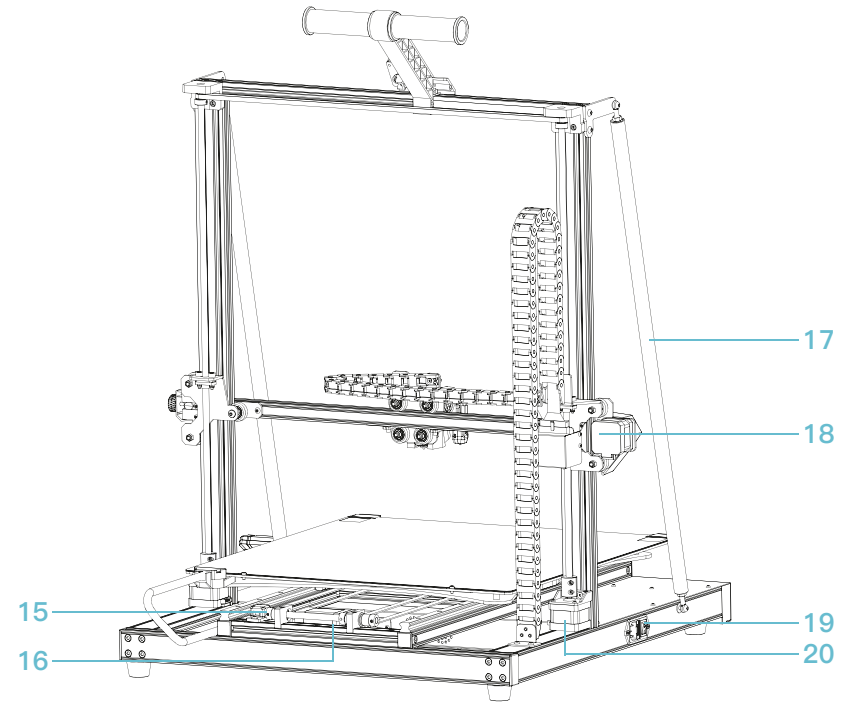
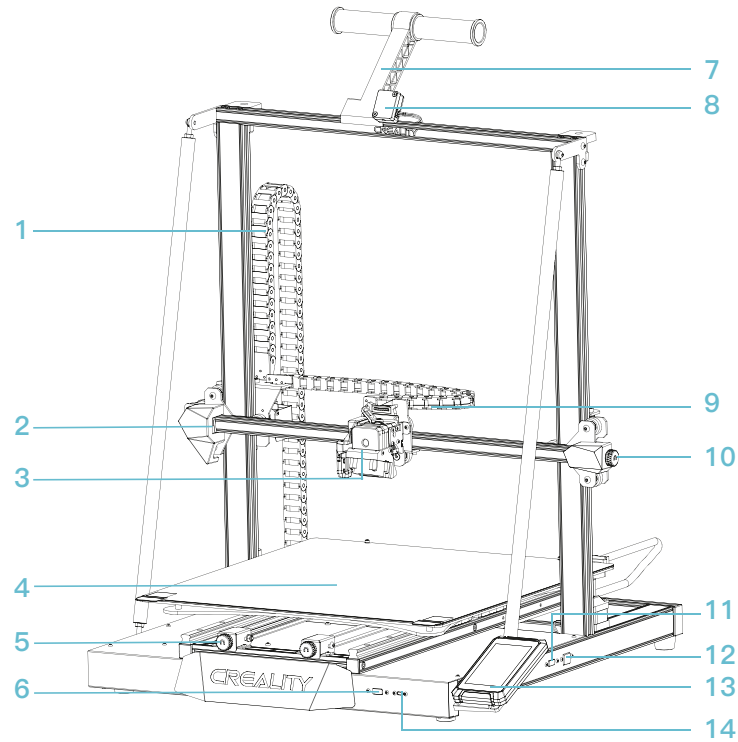

- | | | | |
|---------------------------|---------------------------|---------------------------|-----------------|
| 1 Z-axis Cable Drag Chain | 6 USB Flash Drive Port | 11 Camera Interface | 16 Y-axis Motor |
| 2 X-axis Limit Switch | 7 Material rack | 12 RJ45 Network Interface | 17 Pull Rod |
| 3 Extruder Extrusion Kit | 8 Filament Detection | 13 Display screen | 18 X-axis Motor |
| 4 Printing Platform | 9 X-axis Cable Drag Chain | 14 Type-c port | 19 Power Switch |
| 5 Y-axis Tensioner | 10 X-axis Tensioner | 15 Y-axis Limit Switch | 20 Z-axis Motor |

2. Equipment Parameters



Basic Parameters	
Model	CR-M4
Language	English/ 中文/ Español/ Deutsche/ Français/ Русский/ Português/ Italiano/ Türk
Print Method	USB flash drive/Type-c online printing/WI-FI printing/RJ45 network interface printing
Forming process	FDM
Number of Extruder	1
Printing Size	450*450*470mm
Slice Thickness	0.05-0.35mm
Printing Speed	≤ 120 mm/s, generally 50 mm/s
Nozzle Diameter	0.4 mm (0.6/0.8 mm optional)
Ambient Temperature	5°C~35°C
Hotbed temperature	≤100°C
Nozzle temperature	≤300°C
Filaments	PLA/PETG/TPU/ABS/PLA-Wood/PA/PLA-CF
Operating System	WIN/MAC/Linux
Supported File Format	STL/OBJ/AMF
Power Loss Recovery	Yes
Filament Detection	Yes
Rated Voltage	100-240V~ 50/60Hz
Rated Power	800W

3. Parts List

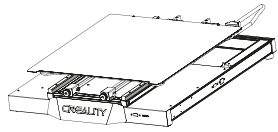

1 Base Component

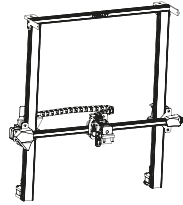

2 Gantry Frame Assembly



3 Z-axis Cable Drag Chain



4 Display screen

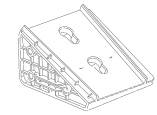

5 Display Screen Frame

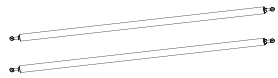

6 Pull Rod x 2



7 Material Rack and Filament Sensor

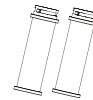

8 Material Barrel x 2

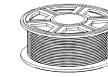

9 Filament



Accessory kit

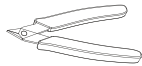

10 Cutting Plier

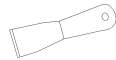

11 Blade

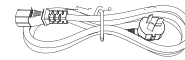

12 Power Cable

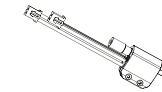

13 Nozzle Kit



14 USB Flash Drive



15 Cable Tie



16 1.2mm Nozzle Cleaner



17 Nozzle Cleaner

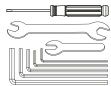

18 Wrench and Screwdriver



19 M5 Flat Gasket x 2



20 Hexagon Socket Head Cap Screw M5*45 x 4

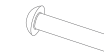

21 Hexagon Socket Button Head Screw M4*20 x 3



22 Countersunk Screw M3*5 x 3



23 Hexagon Socket Button Head Screw M5*10 x 2

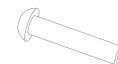

24 Hexagon Socket Button Head Screw M5*25 x 2

Tips: the above accessories are for reference only. Please refer to the physical accessories!

4. Device Installation

4.1 Installation of X-axis Cable Drag Chain

- Insert the extruder adapter terminals into the appropriate interfaces.
- Fix the front end of the X-axis cable drag chain to the extruder back support plate with 3 M3*5 screws.
- Align the clips and then apply gentle pressure to assemble the drag chain at the rear end of the X-axis.

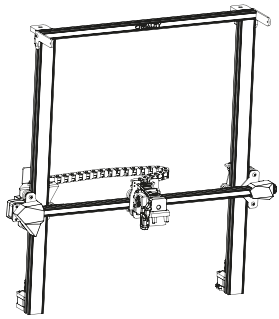

2 Gantry Frame Assembly



22 Countersunk Screw M3*5 x 3

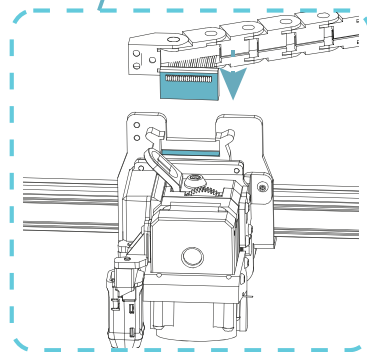
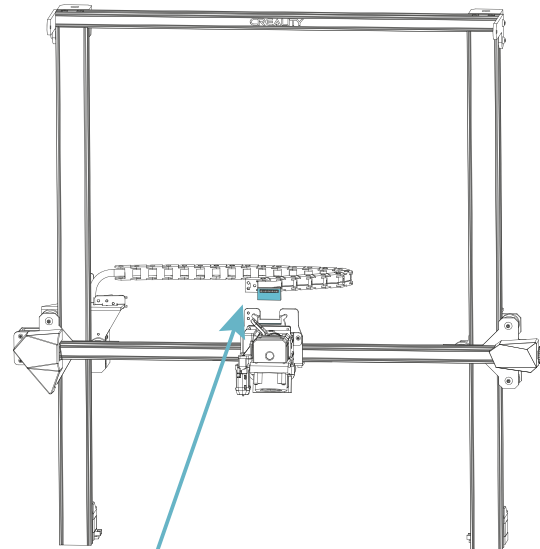

Figure A

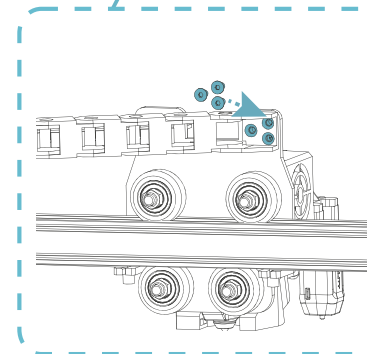
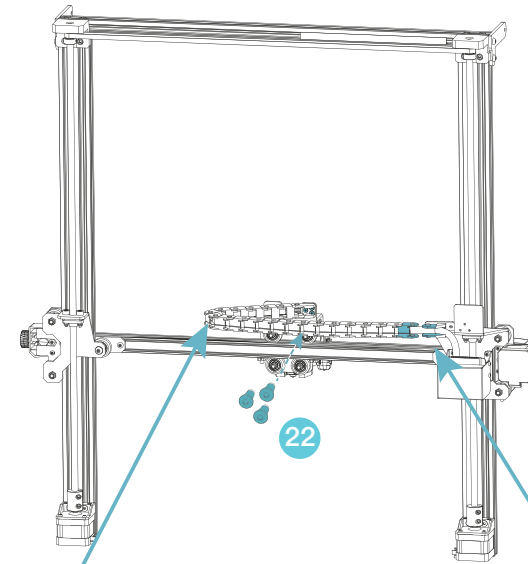

Figure B

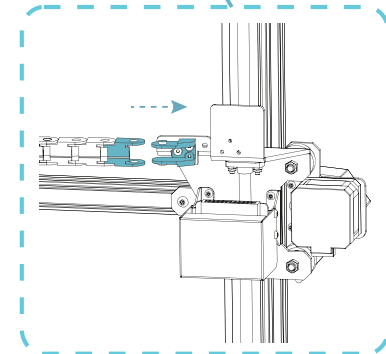
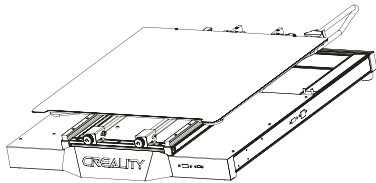

Figure C

4. Device Installation

4.2 Gantry Frame Installation

Place the gantry frame on the base slot and pre-fix it first with 4 M5*45 screws aligned with the holes, then tighten to secure it.



1 Base Component



20 Hexagon Socket Head Cap Screw M5*45 × 4

